

The TTL Data Book Volume 2

1985

Standard TTL, Schottky,
Low-Power Schottky Circuits



TEXAS
INSTRUMENTS

General Information

1

Functional Index

2

TTL Devices

3

Mechanical Data

4

The TTL Data Book

Volume 2



**TEXAS
INSTRUMENTS**

IMPORTANT NOTICE

Texas Instruments (TI) reserves the right to make changes in the devices or the device specifications identified in this publication without notice. TI advises its customers to obtain the latest version of device specifications to verify, before placing orders, that the information being relied upon by the customer is current.

TI warrants performance of its semiconductor products, including SNJ and SMJ devices, to current specifications in accordance with TI's standard warranty. Testing and other quality control techniques are utilized to the extent TI deems such testing necessary to support this warranty. Unless mandated by government requirements, specific testing of all parameters of each device is not necessarily performed.

In the absence of written agreement to the contrary, TI assumes no liability for TI applications assistance, customer's product design, or infringement of patents or copyrights of third parties by or arising from use of semiconductor devices described herein. Nor does TI warrant or represent that any license, either express or implied, is granted under any patent right, copyright, or other intellectual property right of TI covering or relating to any combination, machine, or process in which such semiconductor devices might be or are used.

Specifications contained in this data book supersede all data for these products published by TI in the US before January 1985.

ISBN 0-89512-096-8
Library of Congress No. 83-51810

Copyright © 1985, Texas Instruments Incorporated

INTRODUCTION

In this volume, Texas Instruments presents pertinent technical information on the industry's broadest families of TTL integrated circuits.

You'll find complete specifications on the following product types:

- Standard TTL circuits
 - Series 54/74
 - Series 54/74H
 - Series 54L
- Schottky TTL circuits
 - Schottky-clamped[†] Series 54LS/74LS and 54S/74S

This edition is designed for ease of circuit selection with an alphanumeric index as well as a functional index to all bipolar digital device types available or under development showing the available technologies for each type (Standard TTL, Schottky and Advanced Schottky, Low-Power Schottky and Advanced Low-Power Schottky). Included in the general information section is an explanation of the function tables, parameter measurement information, and typical characteristics related to the TTL products listed in this volume.

Package dimensions given in the Mechanical Data section of this book are in metric measurement (and parenthetically in inches) to simplify board layout for designers involved in metric conversion and new designs.

This volume is one in a series of Digital Bipolar data books available from Texas Instruments. The complete series is listed below:

- The TTL Data Book, Volume 1
 - Indexes, Product Guide, General Information
- The TTL Data Book, Volume 2
 - Standard TTL, Schottky, Low-Power Schottky
- The TTL Data Book, Volume 3
 - Advanced Low-Power Schottky, Advanced Schottky
- TTL Data Book, Volume 3 Supplement
- The TTL Data Book, Volume 4
 - Bipolar Programmable Logic and Memory
- The TTL Data Book, Volume 5
 - Bipolar LSI & Special Functions

Complete technical data for any TI semiconductor/component products are available from your nearest TI field sales office, local authorized TI distributor, or by writing direct to: Marketing Information Services, Texas Instruments Incorporated, P.O. Box 225012, MS 308, Dallas, Texas 75265.

We sincerely hope you will find the new TTL Data Book, Volume 2, a meaningful addition to your technical library.

[†]Integrated Schottky-Barrier diode-clamped transistor is patented by Texas Instruments. U.S. Patent Number 3,463,975.

General Information

1

Functional Index

2

TTL Devices

3

Mechanical Data

4

Device Type	Page No.	Device Type	Page No.
SN5400	SN7400	SN54LS21	SN74LS21
SN54H00 ¹	SN74H00	SN5422	SN7422
SN54L00 ¹		SN54H22 ¹	SN74H22
SN54LS00	SN74LS00	SN54LS22	SN74LS22
SN54S00	SN74S00	SN54S22	SN74S22
SN5401	SN7401	SN5423	SN7423
SN54H01 ¹	SN74H01		SN74LS24
SN54LS01	SN74LS01	SN5425	SN7425
SN5402	SN7402	SN5426	SN7426
SN54L02 ¹		SN54LS26	SN74LS26
SN54LS02	SN74LS02	SN5427	SN7427
SN54S02	SN74S02	SN54LS27	SN74LS27
SN5403	SN7403	SN5428	SN7428
SN54L03 ¹		SN54LS28	SN74LS28
SN54LS03	SN74LS03	SN5430	SN7430
SN54S03	SN74S03	SN54H30 ¹	SN74H30
SN5404	SN7404	SN54L30 ¹	
SN54H04 ¹	SN74H04	SN54LS30	SN74LS30
SN54L04 ¹		SN54S30	SN74S30
SN54LS04	SN74LS04	SN54LS31	SN74LS31
SN54S04	SN74S04	SN5432	SN7432
SN5405	SN7405	SN54LS32	SN74LS32
SN54H05 ¹	SN74H05	SN54S32	SN74S32
SN54LS05	SN74LS05	SN5433	SN7433
SN54S05	SN74S05	SN54LS33	SN74LS33
SN5406	SN7406	SN5437	SN7437
SN5407	SN7407	SN54LS37	SN74LS37
SN5408	SN7408	SN54S37	SN74S37
SN54LS08	SN74LS08	SN5438	SN7438
SN54S08	SN74S08	SN54LS38	SN74LS38
SN5409	SN7409	SN54S38	SN74S38
SN54LS09	SN74LS09	SN5439	SN7439
SN54S09	SN74S09	SN5440	SN7440
SN5410	SN7410	SN54H40 ¹	SN74H40
SN54H10 ¹	SN74H10	SN54LS40	SN74LS40
SN54L10 ¹		SN54S40	SN74S40
SN54LS10	SN74LS10	SN5442A	SN7442A
SN54S10	SN74S10	SN54L42 ¹	
SN54H11 ¹	SN74H11	SN54LS42	SN74LS42
SN54LS11	SN74LS11	SN5443A	SN7443A
SN54S11	SN74S11	SN54L43 ¹	
SN5412	SN7412	SN5444A	SN7444A
SN54LS12	SN74LS12	SN54L44 ¹	
SN5413	SN7413	SN5445	SN7445
SN54LS13	SN74LS13	SN5446A	SN7446A
SN5414	SN7414	SN54L46 ¹	
SN54LS14	SN74LS14	SN5447A	SN7447A
SN54H15 ¹	SN74H15	SN54L47 ¹	
SN54LS15	SN74LS15	SN54LS47	SN74LS47
SN54S15	SN74S15	SN5448	SN7448
SN5416	SN7416	SN54LS48	SN74LS48
SN5417	SN7417	SN5449	SN7449
	SN74LS18	SN54LS49	SN74LS49
	SN74LS19	SN5450	SN7450
SN5420	SN7420	SN54H50 ¹	SN74H50
SN54H20 ¹	SN74H20	SN5451	SN7451
SN54L20 ¹		SN54H51 ¹	SN74H51
SN54LS20	SN74LS20	SN54L51 ¹	
SN54S20	SN74S20	SN54LS51	SN74LS51
SN54H21 ¹	SN74H21	SN54S51	SN74S51

¹For information only, not recommended for new design.

1
GENERAL INFORMATION

ALPHANUMERICAL INDEX

Device Type	Page No.	Device Type	Page No.
SN54H52 ¹	SN74H52	SN54H87 ¹	SN74H87
SN5453	SN7453	SN5490A	SN7490A
SN54H53 ¹	SN74H53	SN54L90 ¹	
SN5454	SN7454	SN54LS90	SN74LS90
SN54H54 ¹	SN74H54	SN5491A	SN7491A
SN54L54 ¹		SN54L91 ¹	
SN54LS54	SN74LS54	SN54LS91	SN74LS91
SN54H55 ¹	SN74H55	SN5492A	SN7492A
SN54L55 ¹		SN54LS92	SN74LS92
SN54LS55	SN74LS55	SN5493A	SN7493A
SN54LS56	SN74LS56	SN54L93 ¹	
SN54LS57	SN74LS57	SN54LS93	SN74LS93
SN5460	SN7460	SN5494	SN7494
SN54H60 ¹	SN74H60	SN5495A	SN7495A
SN54H61 ¹	SN74H61	SN54L95 ¹	
SN54H62 ¹	SN74H62	SN54LS95B	SN74LS95B
SN54LS63	SN74LS63	SN5496	SN7496
SN54S64	SN74S64	SN54L96 ¹	
SN54S65	SN74S65	SN54LS96	SN74LS96
SN54LS68	SN74LS68	SN5497	SN7497
SN54LS69	SN74LS69	SN54L98 ¹	
SN5470	SN7470	SN54L99 ¹	
SN54H71 ¹	SN74H71	SN54100	SN74100
SN54L71 ¹		SN54H101 ¹	SN74H101
SN5472	SN7472	SN54H102 ¹	SN74H102
SN54H72 ¹	SN74H72	SN54H103 ¹	SN74H103
SN54L72 ¹		SN54104	SN74104
SN5473	SN7473	SN54105	SN74105
SN54H73 ¹	SN74H73	SN54H106 ¹	SN74H106
SN54L73 ¹		SN54107	SN74107
SN54LS73A	SN74LS73A	SN54LS107A	SN74LS107A
SN5474	SN7474	SN54H108 ¹	SN74H108
SN54H74 ¹	SN74H74	SN54109	SN74109
SN54L74 ¹		SN54LS109A	SN74LS109A
SN54LS74A	SN74LS74A	SN54110	SN74110
SN54S74	SN74S74	SN54111	SN74111
SN5475	SN7475	SN54LS112A	SN74LS112A
SN54L75 ¹		SN54S112	SN74S112
SN54LS75	SN74LS75	SN54LS113A	SN74LS113A
SN5476	SN7476	SN54S113	SN74S113
SN54H76 ¹	SN74H76	SN54LS114A	SN74LS114A
SN54LS76A	SN74LS76A	SN54S114	SN74S114
SN5477		SN54116	SN74116
SN54L77 ¹		SN54120	SN74120
SN54LS77		SN54121	SN74121
SN54H78 ¹	SN74H78	SN54L121 ¹	
SN54L78 ¹		SN54122	SN74122
SN54LS78A	SN74LS78A	SN54L122 ¹	
SN5480	SN7480	SN54LS122	SN74LS122
SN5482	SN7482	SN54123	SN74123
SN5483A	SN7483A	SN54L123 ¹	
SN54LS83A	SN74LS83A	SN54LS123	SN74LS123
SN5485	SN7485	SN54S124	SN74S124
SN54L85 ¹		SN54125	SN74125
SN54LS85	SN74LS85	SN54LS125A	SN74LS125A
SN54S85	SN74S85	SN54126	SN74126
SN5486	SN7486	SN54LS126A	SN74LS126A
SN54L86 ¹		SN54128	SN74128
SN54LS86A	SN74LS86A	SN54130	SN74130
SN54S86	SN74S86	SN54132	SN74132

¹For information only, not recommended for new design.

Device Type	Page No.	Device Type	Page No.
SN54LS132	SN74LS132	SN54LS165A	SN74LS165A
SN54S132	SN74S132	SN54166	SN74166
SN54S133	SN74S133	SN54LS166A	SN74LS166A
SN54S134	SN74S134	SN54167	SN74167
SN54S135	SN74S135	SN54S168	SN74S168
SN54136	SN74136	SN54LS169B	SN74LS169B
SN54LS136	SN74LS136	SN54S169	SN74S169
SN54LS137	SN74LS137	SN54170	SN74170
SN54LS138	SN74LS138	SN54LS170	SN74LS170
SN54S138	SN74S138	SN54LS171	SN74LS171
SN54LS139A	SN74LS139A	SN54173	SN74172
SN54S139	SN74S139	SN54173	SN74173
SN54S140	SN74S140	SN54LS173A	SN74LS173A
	SN74141	SN54174	SN74174
	SN74142	SN54LS174	SN74LS174
SN54143	SN74143	SN54S174	SN74S174
SN54144	SN74144	SN54175	SN74175
SN54145	SN74145	SN54LS175	SN74LS175
SN54LS145	SN74LS145	SN54S175	SN74S175
SN54147	SN74147	SN54176	SN74176
SN54LS147	SN74LS147	SN54177	SN74177
SN54148	SN74148	SN54178	SN74178
SN54LS148	SN74LS148	SN54179	SN74179
SN54150	SN74150	SN54180	SN74180
SN54151A	SN74151A	SN54181	SN74181
SN54LS151	SN74LS151	SN54LS181	SN74LS181
SN54S151	SN74S151	SN54S181	SN74S181
SN54152A		SN54182	SN74182
SN54LS152		SN54S182	SN74S182
SN54153	SN74153	SN54H183 [†]	SN74H183
SN54L153 [†]		SN54LS183	SN74LS183
SN54LS153	SN74LS153	SN54184	SN74184
SN54S153	SN74S153	SN54185A	SN74185A
SN54154	SN74154	SN54190	SN74190
SN54L154 [†]		SN54LS190	SN74LS190
SN54155	SN74155	SN54191	SN74191
SN54LS155A	SN74LS155A	SN54LS191	SN74LS191
SN54156	SN74156	SN54192	SN74192
SN54LS156	SN74LS156	SN54L192 [†]	SN74LS192
SN54157	SN74157	SN54LS192	SN74LS192
SN54L157 [†]		SN54193	SN74193
SN54LS157	SN74LS157	SN54L193 [†]	
SN54S157	SN74S157	SN54LS193	SN74LS193
SN54LS158	SN74LS158	SN54194	SN74194
SN54S158	SN74S158	SN54LS194A	SN74LS194A
SN54159	SN74159	SN54S194	SN74S194
SN54160	SN74160	SN54195	SN74195
SN54LS160A	SN74LS160A	SN54LS195A	SN74LS195A
SN54161	SN74161	SN54S195	SN74S195
SN54LS161A	SN74LS161A	SN54196	SN74196
SN54162	SN74162	SN54LS196	SN74LS196
SN54LS162A	SN74LS162A	SN54S196	SN74S196
SN54S162	SN74S162	SN54197	SN74197
SN54163	SN74163	SN54LS197	SN74LS197
SN54LS163A	SN74LS163A	SN54S197	SN74S197
SN54S163	SN74S163	SN54198	SN74198
SN54164	SN74164	SN54199	SN74199
SN54L164 [†]		SN54221	SN74221
SN54LS164	SN74LS164	SN54LS221	SN74LS221
SN54165	SN74165	SN54S226	SN74S226

[†]For information only, not recommended for new design.

1

GENERAL INFORMATION

ALPHANUMERICAL INDEX

GENERAL INFORMATION

Device Type	Page No.	Device Type	Page No.
SN54LS240	3-817	SN54LS322A	3-969
SN54S240	3-817	SN54LS323	3-974
SN54LS241	3-817	SN54LS347	3-977
SN54S241	3-817	SN54LS348	3-980
SN54LS242	3-823	SN74S350	3-985
SN54LS243	3-823	SN74351	3-991
SN54LS244	3-817	SN54LS352	3-995
SN54S244	3-817	SN54LS353	3-998
SN54LS245	3-826	SN54LS354	3-1001
SN54246	3-829	SN54LS355	3-1001
SN54247	3-829	SN54LS356	3-1001
SN54LS247	3-829	SN54LS357	3-1001
SN54248	3-829	SN54365A	3-1011
SN54LS248	3-829	SN54LS365A	3-1011
SN54249	3-829	SN54366A	3-1011
SN54LS249	3-829	SN54LS366A	3-1011
SN54251	3-843	SN54367A	3-1011
SN54LS251	3-843	SN54LS367A	3-1011
SN54S251	3-843	SN54368A	3-1011
SN54LS253	3-851	SN54LS368A	3-1011
SN54S253	3-851	SN54LS373	3-1021
SN54LS257B	3-857	SN54S373	3-1021
SN54S257	3-857	SN54LS374	3-1021
SN54LS258B	3-857	SN54S374	3-1021
SN54S258	3-857	SN54LS375	3-1029
SN54259	3-863	SN54376	3-1031
SN54LS259B	3-863	SN54LS377	3-1033
SN54S260	3-867	SN54LS378	3-1033
SN54LS261	3-871	SN54LS379	3-1033
SN54265	3-878	SN54LS381A	3-1037
SN54LS266	3-883	SN54S381	3-1037
SN54S268	3-885	SN54LS382	3-1037
SN54273	3-888	SN54LS384	3-1045
SN54LS273	3-888	SN54LS385	3-1050
SN54276	3-892	SN54LS386A	3-1053
SN54278	3-895	SN54390	3-1055
SN54279	3-899	SN54LS390	3-1055
SN54LS279A	3-899	SN54393	3-1055
SN54LS280	3-903	SN54LS393	3-1055
SN54S280	3-903	SN54LS395A	3-1065
SN54S281	3-909	SN54LS396	3-1069
SN54283	3-917	SN54LS398	3-1073
SN54LS283	3-917	SN54LS399	3-1073
SN54S283	3-917	SN54S412	3-1077
SN54284	3-922	SN54LS422	3-1083
SN54285	3-922	SN54LS423	3-1083
SN54290	3-927	SN54425	3-1089
SN54LS290	3-927	SN54426	3-1089
SN54LS292	3-933	SN54S436	3-1093
SN54293	3-927	SN54S437	3-1093
SN54LS293	3-927	SN54LS440	3-1097
SN54LS294	3-933	SN54LS441	3-1097
SN54LS295B	3-940	SN54LS442	3-1097
SN54LS297	3-945	SN54LS443	3-1097
SN54298	3-951	SN54LS444	3-1097
SN54LS298	3-951	SN54LS445	3-1103
SN54LS299	3-957	SN54LS446	3-1105
SN54S299	3-957	SN54LS447	3-1109
SN54LS320	3-963	SN54LS448	3-1097
SN54LS321	3-963	SN54LS449	3-1105

Device Type	Page No.	Device Type	Page No.	
SN54LS465	SN74LS465	3-1113	SN54LS631	3-1213
SN54LS466	SN74LS466	3-1113	SN54LS636	3-1221
SN54LS467	SN74LS467	3-1113	SN54LS637	3-1221
SN54LS468	SN74LS468	3-1113	SN54LS638	3-1229
SN54490	SN74490	3-1117	SN54LS639	3-1229
SN54LS490	SN74LS490	3-1117	SN54LS640	3-1233
SN54LS540	SN74LS540	3-1127	SN54LS641	3-1233
SN54LS541	SN74LS541	3-1127	SN54LS642	3-1233
SN54LS589	SN74LS589	3-1131	SN54LS643	3-1233
SN54LS590	SN74LS590	3-1137	SN54LS644	3-1233
SN54LS591	SN74LS591	3-1137	SN54LS645	3-1233
SN54LS592	SN74LS592	3-1141	SN54LS646	3-1241
SN54LS593	SN74LS593	3-1141	SN54LS647	3-1241
SN54LS594	SN74LS594	3-1149	SN54LS648	3-1241
SN54LS595	SN74LS595	3-1153	SN54LS649	3-1241
SN54LS596	SN74LS596	3-1153	SN54LS651	3-1251
SN54LS597	SN74LS597	3-1159	SN54LS652	3-1251
SN54LS598	SN74LS598	3-1159	SN54LS653	3-1251
SN54LS599	SN74LS599	3-1149	SN54LS654	3-1251
	SN74LS600A	3-1167	SN54LS668	3-1259
	SN74LS601A	3-1167	SN54LS669	3-1259
	SN74LS602A	3-1167	SN54LS670	3-1269
	SN74LS603A	3-1167	SN54LS671	3-1277
SN54LS604	SN74LS604	3-1175	SN54LS672	3-1277
SN54LS605	SN74LS605	3-1175	SN54LS673	3-1283
SN54LS606	SN74LS606	3-1175	SN54LS674	3-1283
SN54LS607	SN74LS607	3-1175	SN54LS681	3-1289
SN54LS608	SN74LS608	3-1181	SN54LS682	3-1295
SN54LS610	SN74LS610	3-1187	SN54LS683	3-1295
SN54LS611	SN74LS611	3-1187	SN54LS684	3-1295
SN54LS612	SN74LS612	3-1187	SN54LS685	3-1295
SN54LS613	SN74LS613	3-1187	SN54LS686	3-1295
SN54LS620	SN74LS620	3-1197	SN54LS687	3-1295
SN54LS621	SN74LS621	3-1197	SN54LS688	3-1295
SN54LS622	SN74LS622	3-1197	SN54LS689	3-1295
SN54LS623	SN74LS623	3-1197	SN54LS690	3-1303
SN54LS624	SN74LS624	3-1203	SN54LS691	3-1303
SN54LS625	SN74LS625	3-1203	SN54LS692	3-1303
SN54LS626	SN74LS626	3-1203	SN54LS693	3-1303
SN54LS627	SN74LS627	3-1203	SN54LS696	3-1315
SN54LS628	SN74LS628	3-1203	SN54LS697	3-1315
SN54LS629	SN74LS629	3-1203	SN54LS698	3-1315
SN54LS630	SN74LS630	3-1213	SN54LS699	3-1315

INTRODUCTION

These symbols, terms, and definitions are in accordance with those currently agreed upon by the JEDEC Council of the Electronic Industries Association (EIA) for use in the USA and by the International Electrotechnical Commission (IEC) for international use.

PART I — OPERATING CONDITIONS AND CHARACTERISTICS (IN SEQUENCE BY LETTER SYMBOLS)

- f_{max}** **Maximum clock frequency**
The highest rate at which the clock input of a bistable circuit can be driven through its required sequence while maintaining stable transitions of logic level at the output with input conditions established that should cause changes of output logic level in accordance with the specification.
- I_{CC}** **Supply current**
The current into* the V_{CC} supply terminal of an integrated circuit.
- I_{CCH}** **Supply current, outputs high**
The current into* the V_{CC} supply terminal of an integrated circuit when all (or a specified number) of the outputs are at the high level.
- I_{CCL}** **Supply current, outputs low**
The current into* the V_{CC} supply terminal of an integrated circuit when all (or a specified number) of the outputs are at the low level.
- I_{IH}** **High-level input current**
The current into* an input when a high-level voltage is applied to that input.
- I_{IL}** **Low-level input current**
The current into* an input when a low-level voltage is applied to that input.
- I_{OH}** **High-level output current**
The current into* an output with input conditions applied that, according to the product specification, will establish a high level at the output.
- I_{OL}** **Low-level output current**
The current into* an output with input conditions applied that, according to the product specification, will establish a low level at the output.
- I_{OS}** **Short-circuit output current**
The current into* an output when that output is short-circuited to ground (or other specified potential) with input conditions applied to establish the output logic level farthest from ground potential (or other specified potential).
- I_{OZH}** **Off-state (high-impedance-state) output current (of a three-state output) with high-level voltage applied**
The current flowing into* an output having three-state capability with input conditions established that, according to the product specification, will establish the high-impedance state at the output and with a high-level voltage applied to the output.
NOTE: This parameter is measured with other input conditions established that would cause the output to be at a low level if it were enabled.

*Current out of a terminal is given as a negative value.

1
GENERAL INFORMATION

GLOSSARY

TTL SYMBOLS, TERMS, AND DEFINITIONS

I_{OZL}	Off-state (high-impedance-state) output current (of a three-state output) with low-level voltage applied The current flowing into* an output having three-state capability with input conditions established that, according to the product specification, will establish the high-impedance state at the output and with a low-level voltage applied to the output. NOTE: This parameter is measured with other input conditions established that would cause the output to be at a high level if it were enabled.
V_{IH}	High-level input voltage An input voltage within the more positive (less negative) of the two ranges of values used to represent the binary variables. NOTE: A minimum is specified that is the least-positive value of high-level input voltage for which operation of the logic element within specification limits is guaranteed.
V_{IK}	Input clamp voltage An input voltage in a region of relatively low differential resistance that serves to limit the input voltage swing.
V_{IL}	Low-level input voltage An input voltage level within the less positive (more negative) of the two ranges of values used to represent the binary variables. NOTE: A maximum is specified that is the most-positive value of low-level input voltage for which operation of the logic element within specification limits is guaranteed.
V_{OH}	High-level output voltage The voltage at an output terminal with input conditions applied that, according to the product specification, will establish a high level at the output.
V_{OL}	Low-level output voltage The voltage at an output terminal with input conditions applied that, according to the product specification, will establish a low level at the output.
t_a	Access time The time interval between the application of a specific input pulse and the availability of valid signals at an output.
t_{dis}	Disable time (of a three-state output) The time interval between the specified reference points on the input and output voltage waveforms, with the three-state output changing from either of the defined active levels (high or low) to a high-impedance (off) state. (t _{dis} = t _{PHZ} or t _{PLZ}).
t_{en}	Enable time (of a three-state output) The time interval between the specified reference points on the input and output voltage waveforms, with the three-state output changing from a high-impedance (off) state to either of the defined active levels (high or low). (t _{en} = t _{pZH} or t _{pZL}).

*Current out of a terminal is given as a negative value.

t_h	<p>Hold time The time interval during which a signal is retained at a specified input terminal after an active transition occurs at another specified input terminal.</p> <p>NOTES: 1. The hold time is the actual time interval between two signal events and is determined by the system in which the digital circuit operates. A minimum value is specified that is the shortest interval for which correct operation of the digital circuit is guaranteed.</p> <p style="padding-left: 40px;">2. The hold time may have a negative value in which case the minimum limit defines the longest interval (between the release of the signal and the active transition) for which correct operation of the digital circuit is guaranteed.</p>
t_{pd}	<p>Propagation delay time The time between the specified reference points on the input and output voltage waveforms with the output changing from one defined level (high or low) to the other defined level. ($t_{pd} = t_{PHL}$ or t_{PLH}).</p>
t_{PHL}	<p>Propagation delay time, high-to-low-level output The time between the specified reference points on the input and output voltage waveforms with the output changing from the defined high level to the defined low level.</p>
t_{PHZ}	<p>Disable time (of a three-state output) from high level The time interval between the specified reference points on the input and output voltage waveforms with the three-state output changing from the defined high level to a high-impedance (off) state.</p>
t_{PLH}	<p>Propagation delay time, low-to-high-level output The time between the specified reference points on the input and output voltage waveforms with the output changing from the defined low level to the defined high level.</p>
t_{PLZ}	<p>Disable time (of a three-state output) from low level The time interval between the specified reference points on the input and output voltage waveforms with the three-state output changing from the defined low level to a high-impedance (off) state.</p>
t_{PZH}	<p>Enable time (of a three-state output) to high level The time interval between the specified reference points on the input and output voltage waveforms with the three-state output changing from a high-impedance (off) state to the defined high level.</p>
t_{PZL}	<p>Enable time (of a three-state output) to low level The time interval between the specified reference points on the input and output voltage waveforms with the three-state output changing from a high-impedance (off) state to the defined low level.</p>
t_{sr}	<p>Sense recovery time The time interval needed to switch a memory from a write mode to a read mode and to obtain valid data signals at the output.</p>
t_{su}	<p>Setup time The time interval between the application of a signal at a specified input terminal and a subsequent active transition at another specified input terminal.</p> <p>NOTES: 1. The setup time is the actual time interval between two signal events and is determined by the system in which the digital circuit operates. A minimum value is specified that is the shortest interval for which correct operation of the digital circuit is guaranteed.</p> <p style="padding-left: 40px;">2. The setup time may have a negative value in which case the minimum limit defines the longest interval (between the active transition and the application of the other signal) for which correct operation of the digital circuit is guaranteed.</p>
t_w	<p>Pulse duration (width) The time interval between specified reference points on the leading and trailing edges of the pulse waveform.</p>

GLOSSARY

TTL SYMBOLS, TERMS, AND DEFINITIONS

PART II — CLASSIFICATION OF CIRCUIT COMPLEXITY

Gate Equivalent Circuit

A basic unit-of-measure of relative digital-circuit complexity. The number of gate equivalent circuits is that number of individual logic gates that would have to be interconnected to perform the same function.

Large-Scale Integration, LSI

A concept whereby a complete major subsystem or system function is fabricated as a single microcircuit. In this context a major subsystem or system, whether digital or linear, is considered to be one that contains 100 or more equivalent gates or circuitry of similar complexity.

Medium-Scale Integration, MSI

A concept whereby a complete subsystem or system function is fabricated as a single microcircuit. The subsystem or system is smaller than for LSI, but whether digital or linear, is considered to be one that contains 12 or more equivalent gates or circuitry of similar complexity.

Small-Scale Integration, SSI



Integrated circuits of less complexity than medium-scale integration (MSI).

Very-Large-Scale Integration, VLSI



The description of any IC technology that is much more complex than large-scale integration (LSI), and involves a much higher equivalent gate count. At this time an exact definition including a minimum gate count has not been standardized by JEDEC or the IEEE.



The following symbols are used in function tables on TI data sheets:

- H = high level (steady state)
- L = low level (steady state)
- ↑ = transition from low to high level
- ↓ = transition from high to low level
- = value/level or resulting value/level is routed to indicated destination
- ↻ = value/level is re-entered
- X = irrelevant (any input, including transitions)
- Z = off (high-impedance) state of a 3-state-output
- a . . h = the level of steady-state inputs at inputs A through H respectively
- Q₀ = level of Q before the indicated steady-state input conditions were established
- \bar{Q}_0 = complement of Q₀ or level of \bar{Q} before the indicated steady-state input conditions were established
- Q_n = level of Q before the most recent active transition indicated by ↓ or ↑
-  = one high-level pulse
-  = one low-level pulse
- TOGGLE = each output changes to the complement of its previous level on each active transition indicated by ↓ or ↑.

If, in the input columns, a row contains only the symbols H, L, and/or X, this means the indicated output is valid whenever the input configuration is achieved and regardless of the sequence in which it is achieved. The output persists so long as the input configuration is maintained.

If, in the input columns, a row contains H, L, and/or X together with ↑ and/or ↓, this means the output is valid whenever the input configuration is achieved but the transition(s) must occur following the achievement of the steady-state levels. If the output is shown as a level (H, L, Q₀, or \bar{Q}_0), it persists so long as the steady-state input levels and the levels that terminate indicated transitions are maintained. Unless otherwise indicated, input transitions in the opposite direction to those shown have no effect at the output. (If the output is shown as a pulse,  or , the pulse follows the indicated input transition and persists for an interval dependent on the circuit.)

EXPLANATION OF FUNCTION TABLES

Among the most complex function tables in this book are those of the shift registers. These embody most of the symbols used in any of the function tables, plus more. Below is the function table of a 4-bit bidirectional universal shift register, e.g., type SN74194.

FUNCTION TABLE

CLEAR	MODE		CLOCK	INPUTS				OUTPUTS					
	S1	S0		SERIAL		PARALLEL				Q _A	Q _B	Q _C	Q _D
				LEFT	RIGHT	A	B	C	D				
L	X	X	X	X	X	X	X	X	X	L	L	L	L
H	X	X	L	X	X	X	X	X	X	Q _{A0}	Q _{B0}	Q _{C0}	Q _{D0}
H	H	H	↑	X	X	a	b	c	d	a	b	c	d
H	L	H	↑	X	H	X	X	X	X	H	Q _{An}	Q _{Bn}	Q _{Cn}
H	L	H	↑	X	L	X	X	X	X	L	Q _{An}	Q _{Bn}	Q _{Cn}
H	H	L	↑	H	X	X	X	X	X	Q _{Bn}	Q _{Cn}	Q _{Dn}	H
H	H	L	↑	L	X	X	X	X	X	Q _{Bn}	Q _{Cn}	Q _{Dn}	L
H	L	L	X	X	X	X	X	X	X	Q _{A0}	Q _{B0}	Q _{C0}	Q _{D0}

The first line of the table represents a synchronous clearing of the register and says that if clear is low, all four outputs will be reset low regardless of the other inputs. In the following lines, clear is inactive (high) and so has no effect.

The second line shows that so long as the clock input remains low (while clear is high), no other input has any effect and the outputs maintain the levels they assumed before the steady-state combination of clear high and clock low was established. Since on other lines of the table only the rising transition of the clock is shown to be active, the second line implicitly shows that no further change in the outputs will occur while the clock remains high or on the high-to-low transition of the clock.

The third line of the table represents synchronous parallel loading of the register and says that if S1 and S0 are both high then, without regard to the serial input, the data entered at A will be at output Q_A, data entered at B will be at Q_B, and so forth, following a low-to-high clock transition.

The fourth and fifth lines represent the loading of high- and low-level data, respectively, from the shift-right serial input and the shifting of previously entered data one bit; data previously at Q_A is now at Q_B, the previous levels of Q_B and Q_C are now at Q_C and Q_D respectively, and the data previously at Q_D is no longer in the register. This entry of serial data and shift takes place on the low-to-high transition of the clock when S1 is low and S0 is high and the levels at inputs A through D have no effect.

The sixth and seventh lines represent the loading of high- and low-level data, respectively, from the shift-left serial input and the shifting of previously entered data one bit; data previously at Q_B is now at Q_A, the previous levels of Q_C and Q_D are now at Q_B and Q_C, respectively, and the data previously at Q_A is no longer in the register. This entry of serial data and shift takes place on the low-to-high transition of the clock when S1 is high and S0 is low and the levels at inputs A through D have no effect.

The last line shows that as long as both mode inputs are low, no other input has any effect and, as in the second line, the outputs maintain the levels they assumed before the steady-state combination of clear high and both mode inputs low was established.

PARAMETER MEASUREMENT INFORMATION

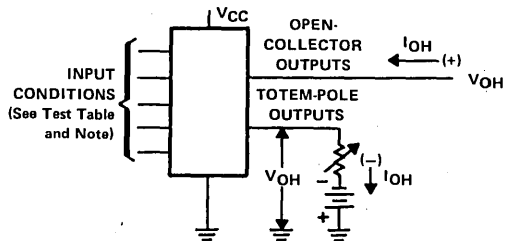

NOTE: For functions having three-state outputs, input conditions are maintained which will cause the outputs to be enabled (low-impedance).

FIGURE 1. V_{IH} , V_{IL} , V_{OH} , I_{OH}

TEST TABLE	
FUNCTION	INPUT CONDITIONS
NAND	Input under test at V_{IL} max, all others at 4.5 V
AND	All inputs at V_{IH} min
NOR	All inputs at V_{IL} max
OR	Input under test at V_{IH} min, all others at GND
AND-OR	Inputs under test (a set including one input of each AND gate) at V_{IL} max, all others at 4.5 V
INVERT	
AND-OR	All inputs of AND gate under test at V_{IH} min, all others at GND

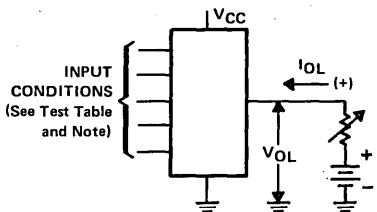

NOTE: For functions having three-state outputs, input conditions are maintained which will cause the outputs to be enabled (low-impedance).

FIGURE 2. V_{IH} , V_{IL} , V_{OL}

TEST TABLE	
FUNCTION	INPUT CONDITIONS
NAND	All inputs at V_{IH} min
AND	Input under test at V_{IL} max, all others at 4.5 V
NOR	Input under test at V_{IH} min, others at GND
OR	All inputs at V_{IL} max
AND-OR	All inputs of AND gate under test at V_{IH} min, all others at GND
INVERT	
AND-OR	Inputs under test (a set including one input of each AND gate) at V_{IH} min, all others at 4.5 V

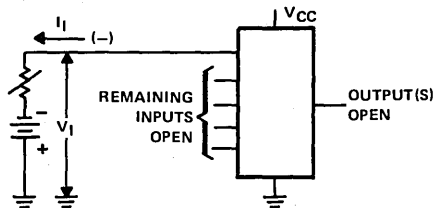

NOTE: Each input is tested separately.

FIGURE 3. V_I

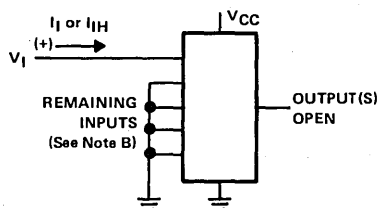

NOTES: A. Each input is tested separately.
 B. When testing AND-OR-INVERT or AND-OR gates, each AND gate is tested separately with inputs of AND gates not under test open when testing I_L and grounded when testing I_{IH} .

FIGURE 4. I_L , I_{IH}

GENERAL INFORMATION

PARAMETER MEASUREMENT INFORMATION

1

GENERAL INFORMATION

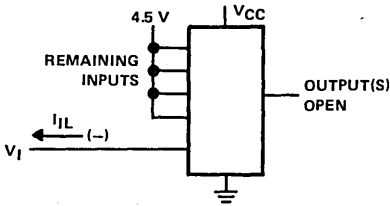

NOTES: A. Each input is tested separately.
 B. When testing AND-OR-INVERT or AND-OR gates, each AND gate is tested separately with input of AND gates not under test open.

FIGURE 5. I_{IL}

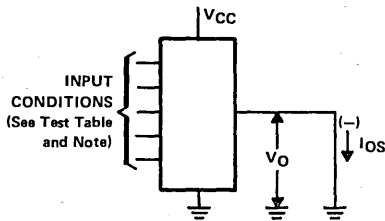

TEST TABLE

FUNCTION	INPUT CONDITIONS
NAND	All inputs at GND
AND	All inputs at 4.5 V
NOR	All inputs at GND
OR	All inputs at 4.5 V
AND-OR-INVERT	All inputs at GND
AND-OR	All inputs at 4.5 V

NOTE: For functions having three-state outputs, input conditions are maintained which will cause the outputs to be enabled (low-impedance).

FIGURE 6. I_{OS}, I_O

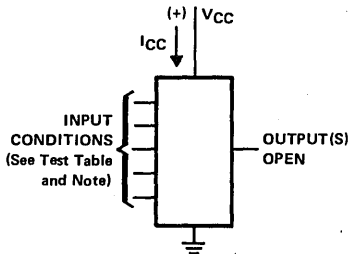

TEST TABLE

FUNCTION	INPUT CONDITIONS FOR I_{CCH}	INPUT CONDITIONS FOR I_{CCL}
NAND	All inputs at GND	All inputs at 4.5 V
AND	All inputs at 4.5 V	All inputs at GND
NOR	All inputs at GND	One input at 4.5 V, all others at GND
OR	One input at 4.5 V, all others at GND	All inputs at GND
AND-OR-INVERT	All inputs at GND	All inputs of one AND gate at 4.5 V, all others at GND
AND-OR	All inputs of one AND gate at 4.5 V, all others at GND	All inputs at GND

NOTE: I_{CC} is measured simultaneously for all functions in a package. The average-per-gate values are calculated from the appropriate one of the following equations.:

$$I_{CC}, I_{CCH}, \text{ or } I_{CCL} \text{ (average per gate or flip-flop)} = \frac{\text{total } I_{CC}, I_{CCH}, \text{ or } I_{CCL}}{\text{(number of gates or flip-flops in package)}}$$

$$I_{CC} \text{ (average per gate, 50\% duty cycle)} = \frac{I_{CCH} + I_{CCL}}{2 \text{ (number of gates in package)}}$$

FIGURE 7. I_{CC}

PARAMETER MEASUREMENT INFORMATION

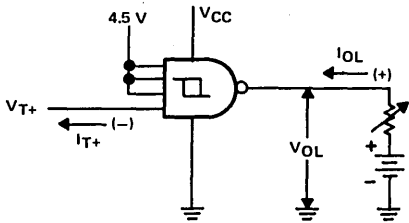

FIGURE 8. V_{T+} , I_{T+} , V_{OL}
 (FOR NAND SCHMITT TRIGGERS)

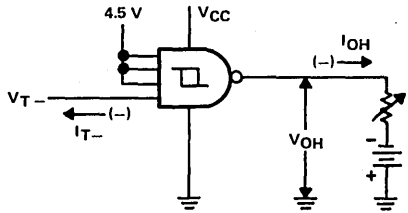

FIGURE 9. V_{T-} , I_{T-} , V_{OH}
 (FOR NAND SCHMITT TRIGGERS)

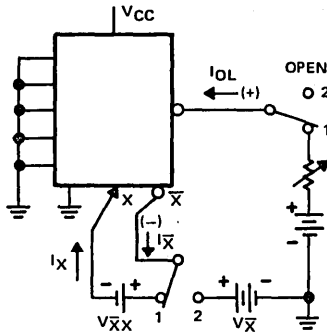

FIGURE 10. I_X (FOR EXPANDABLE GATES)

- NOTES: A. Switches are in position 1 for SN54'/SN74', position 2 for SN54H'/SN74H'.
- B. The I_X limit for SN54' and SN74' circuits may be verified by an alternate equivalent procedure. The V_{XX} source is replaced by a resistor (see table below) in parallel with a voltmeter between the X and \bar{X} pins. If the measured voltage, V_{XX} , is less than 0.4, the specified limit for I_X is met.

RESISTANCE VALUE TABLE

SN5423	114 Ω
SN5450, SN5453	138 Ω
SN7423	105 Ω
SN7450, SN7453	130 Ω

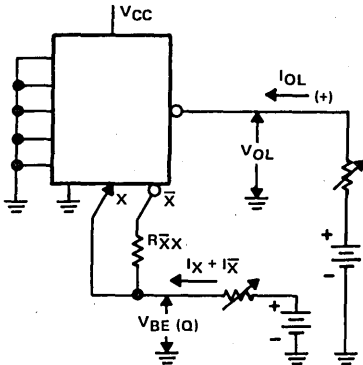

FIGURE 11. $V_{BE(Q)}$ (FOR EXPANDABLE GATES)

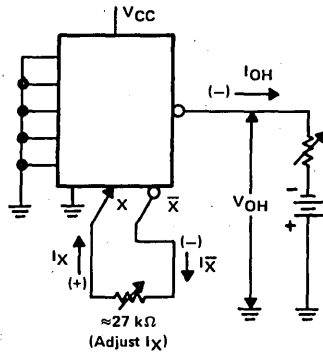

FIGURE 12. V_{OH} (FOR EXPANDABLE GATES)

PARAMETER MEASUREMENT INFORMATION

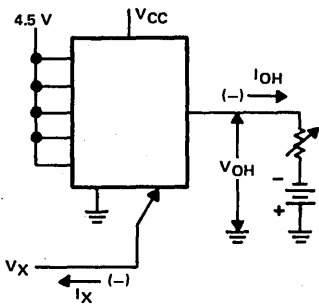

FIGURE 13. V_{OH} (FOR EXPANDABLE GATES)

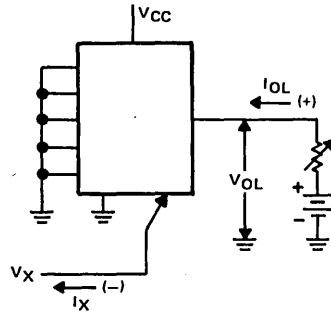

FIGURE 14. V_{OL} (FOR EXPANDABLE GATES)

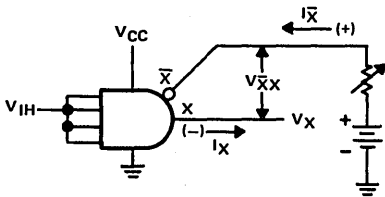

FIGURE 15. ON-STATE CHARACTERISTICS FOR EXPANDERS

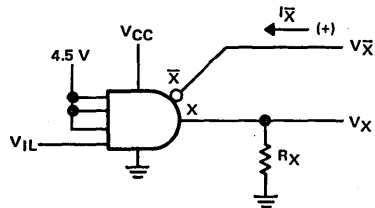

FIGURE 16. OFF-STATE CHARACTERISTICS FOR EXPANDERS

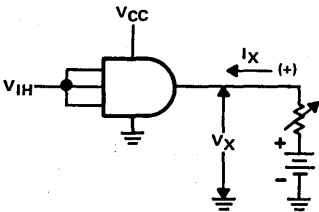

FIGURE 17. ON-STATE CHARACTERISTICS FOR EXPANDERS

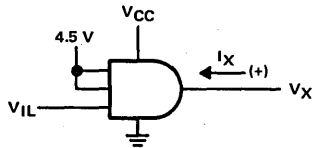

FIGURE 18. OFF-STATE CHARACTERISTICS FOR EXPANDERS

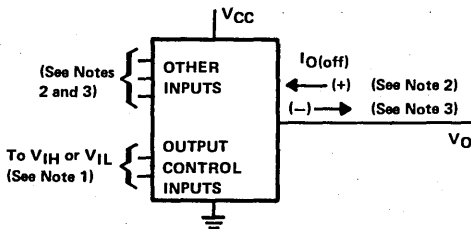
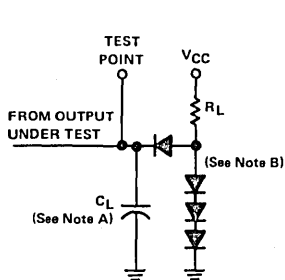

FIGURE 19. $I_{O(off)}$ (THREE-STATE OUTPUTS)

- NOTES:
1. Input conditions are maintained which will ensure that the three-state output(s) is (are) disabled to the high-impedance state. See function table or logic for the particular device.
 2. When testing for current into the output with a high-level output voltage, input conditions are applied that would cause the output to be low if it were enabled.
 3. When testing for current out of the output with a low-level output voltage, input conditions are applied that would cause the output to be high if it were enabled.

PARAMETER MEASUREMENT INFORMATION



LOAD CIRCUIT FOR BI-STATE TOTEM-POLE OUTPUTS

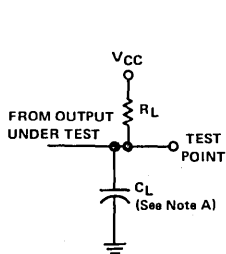

LOAD CIRCUIT FOR OPEN-COLLECTOR OUTPUTS

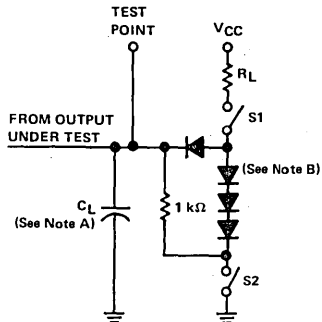

LOAD CIRCUIT FOR THREE-STATE OUTPUTS

NOTES: A. C_L includes probe and jig capacitance.
B. All diodes are 1N3064 or equivalent.

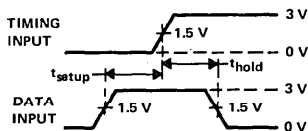

VOLTAGE WAVEFORMS SETUP AND HOLD TIMES

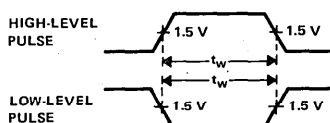

VOLTAGE WAVEFORMS PULSE WIDTHS

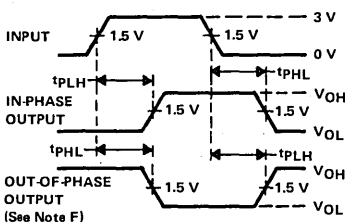

VOLTAGE WAVEFORMS PROPAGATION DELAY TIMES

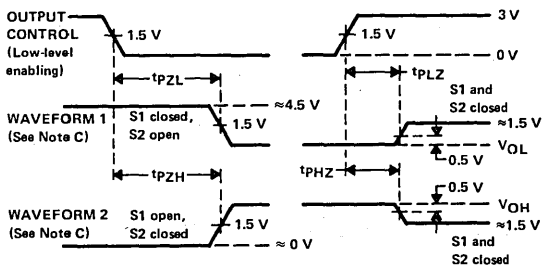

VOLTAGE WAVEFORMS ENABLE AND DISABLE TIMES, THREE-STATE OUTPUTS

NOTES: C. Waveform 1 is for an output with internal conditions such that the output is low except when disabled by the output control. Waveform 2 is for an output with internal conditions such that the output is high except when disabled by the output control.
D. In the examples above, the phase relationships between inputs and outputs have been chosen arbitrarily.
E. All input pulses are supplied by generators having the following characteristics: PRR \leq 1 MHz, $Z_{out} = 50 \Omega$ and:
For Series 54/74 and 54H/74H, $t_r \leq 7$ ns, $t_f \leq 7$ ns;
For Specified[†] Series 54L/74L devices: $t_r \leq 10$ ns, $t_f \leq 10$ ns;
For Series 54S/74S, $t_r \leq 2.5$ ns, $t_f \leq 2.5$ ns.
F. When measuring propagation delay times of 3-state outputs, switches S1 and S2 are closed.
G. The outputs are measured one at a time with one input transition per measurement.

[†]L42, 'L43, 'L44, 'L46, 'L47, 'L75, 'L77, 'L96, 'L121, 'L122, 'L123, 'L153, 'L154, 'L157, 'L164

1
GENERAL INFORMATION

PARAMETER MEASUREMENT INFORMATION

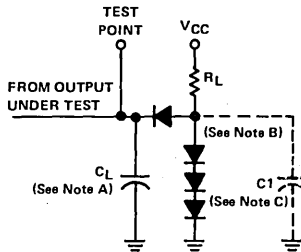

LOAD CIRCUIT FOR BI-STATE TOTEM-POLE OUTPUTS

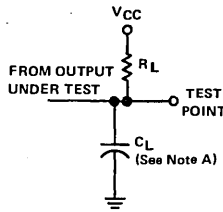

LOAD CIRCUIT FOR OPEN-COLLECTOR OUTPUTS

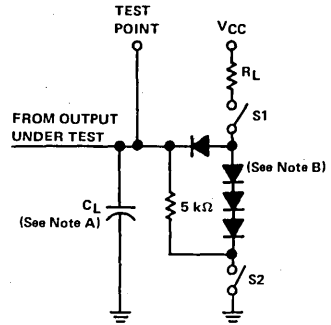

LOAD CIRCUIT FOR THREE-STATE OUTPUTS

NOTES: A. C_L includes probe and jig capacitance.
 B. All diodes are 1N3064 or equivalent.
 C. C_1 (30 pF) is used for testing Series 54L devices only.

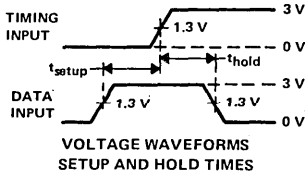

VOLTAGE WAVEFORMS SETUP AND HOLD TIMES

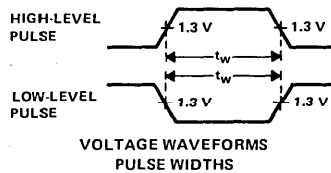

VOLTAGE WAVEFORMS PULSE WIDTHS

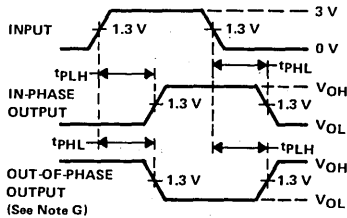

VOLTAGE WAVEFORMS PROPAGATION DELAY TIMES

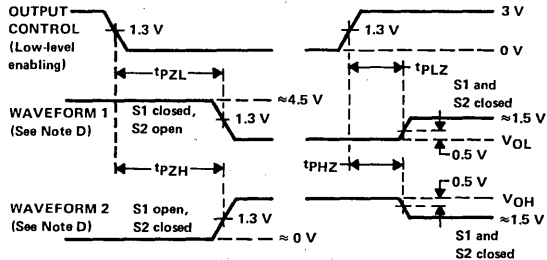

VOLTAGE WAVEFORMS ENABLE AND DISABLE TIMES, THREE-STATE OUTPUTS

NOTES: D. Waveform 1 is for an output with internal conditions such that the output is low except when disabled by the output control. Waveform 2 is for an output with internal conditions such that the output is high except when disabled by the output control.
 E. In the examples above, the phase relationships between inputs and outputs have been chosen arbitrarily.
 F. All input pulses are supplied by generators having the following characteristics: PRR \leq 1 MHz, $Z_{out} \approx 50 \Omega$ and:
 For Series 54L/74L gates and inverters, $t_r = 60$ ns, $t_f = 60$ ns;
 For Series 54L/74L flip-flops and MSI, $t_r \leq 25$ ns, $t_f \leq 25$ ns;
 For Series 54LS/74LS, $t_r \leq 15$ ns, $t_f \leq 6$ ns.
 G. When measuring propagation delay times of 3-state outputs, switches S1 and S2 are closed.
 H. The outputs are measured one at a time with one input transition per measurement.

†L42, 'L43, 'L44, 'L46, 'L47, 'L75, 'L77, 'L96, 'L121, 'L122, 'L123, 'L153, 'L154, 'L157, 'L164

TYPICAL CHARACTERISTICS†

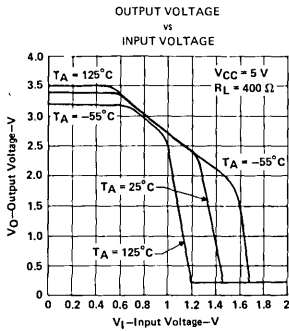

FIGURE A1

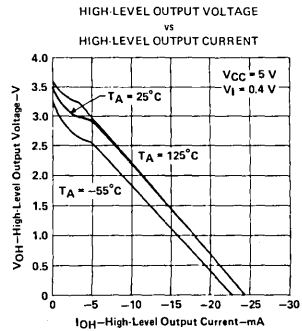

FIGURE A2

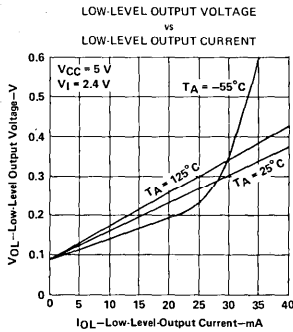

FIGURE A3

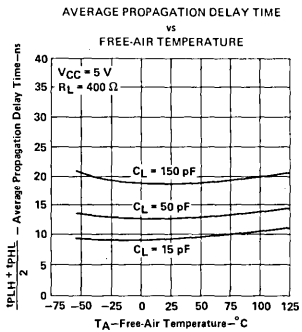

FIGURE A4

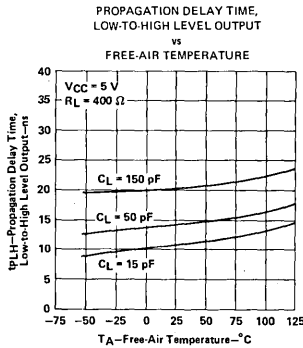

FIGURE A5

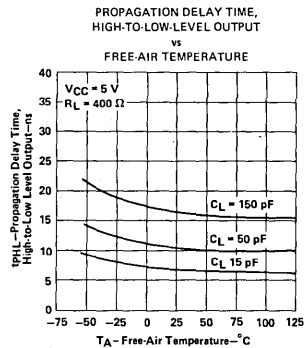

FIGURE A6

† Data for temperatures below 0°C and above 70°C are applicable for Series 54 circuits only. Data as shown are applicable specifically for the NAND gates with totem-pole outputs.

GENERAL INFORMATION

SERIES 54H/74H HIGH-SPEED TRANSISTOR-TRANSISTOR LOGIC

TYPICAL CHARACTERISTICS†

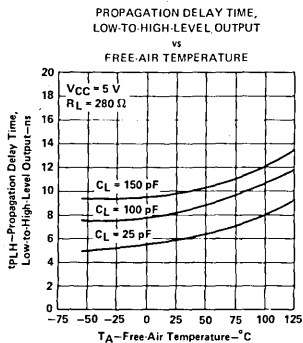

FIGURE B1

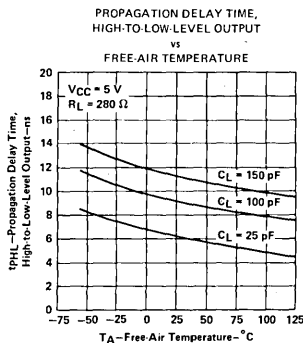

FIGURE B2

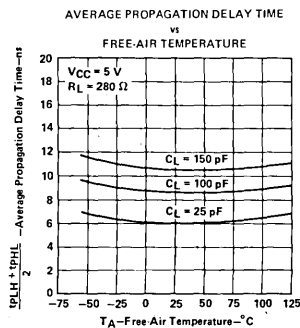

FIGURE B3

†Data for temperatures below 0°C and above 70°C are applicable for Series 54H circuits only.
Data as shown are applicable specifically for the NAND gates with totem-pole outputs.

TYPICAL CHARACTERISTICS

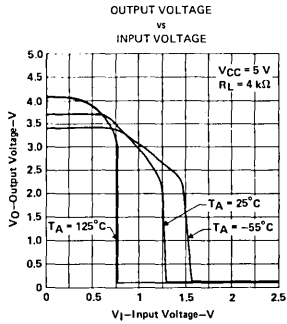

FIGURE C1

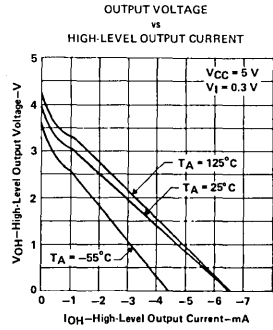

FIGURE C2

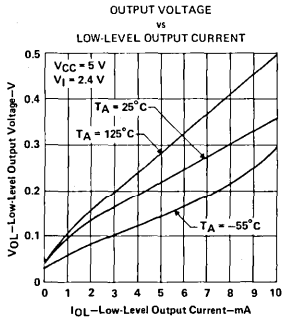

FIGURE C3

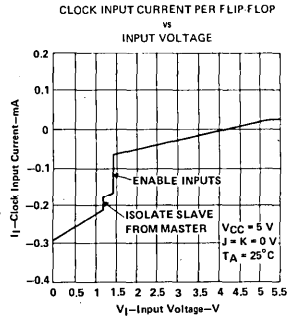

FIGURE C4

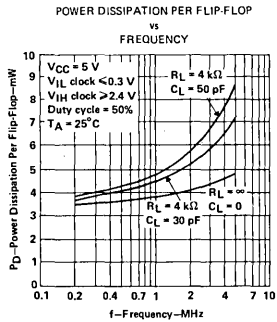

FIGURE C5

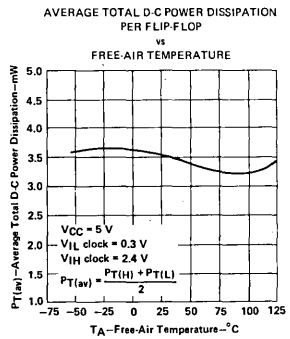

FIGURE C6

Unless otherwise noted, data as shown are applicable specifically for the NAND gates with totem-pole outputs.

GENERAL INFORMATION

TYPICAL CHARACTERISTICS

1
GENERAL INFORMATION

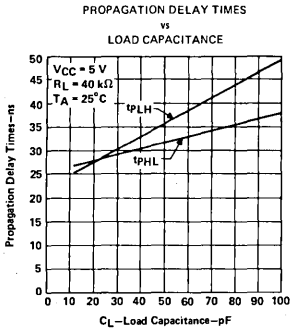

FIGURE C7

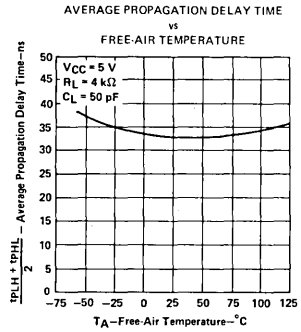

FIGURE C8

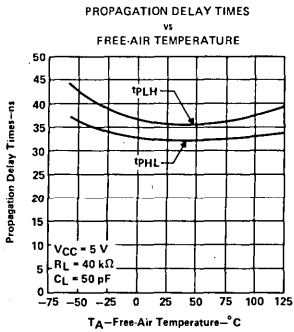

FIGURE C9

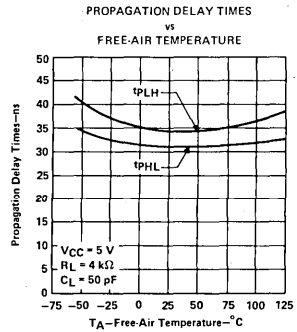

FIGURE C10

Data as shown are applicable specifically for the NAND gates with totem-pole outputs.

SERIES 54LS/74LS LOW-POWER SCHOTTKY-CLAMPED TRANSISTOR-TRANSISTOR LOGIC

TYPICAL CHARACTERISTICS†

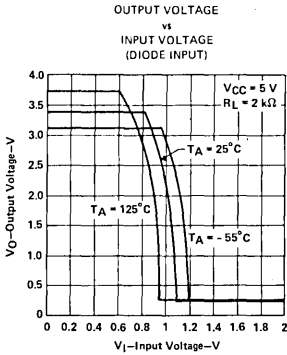

FIGURE D1

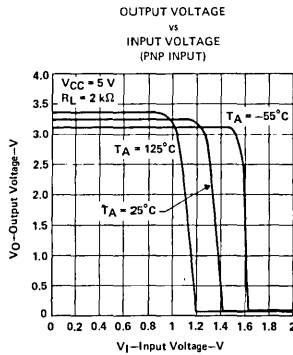

FIGURE D2

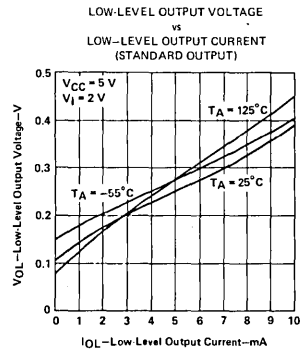

FIGURE D3

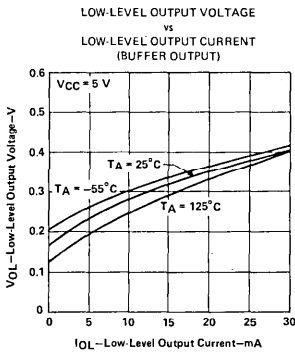

FIGURE D4

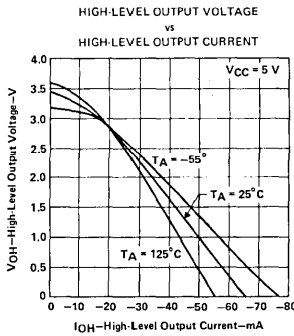

FIGURE D5

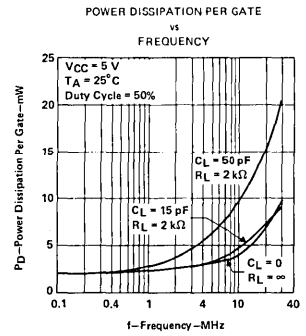

FIGURE D6

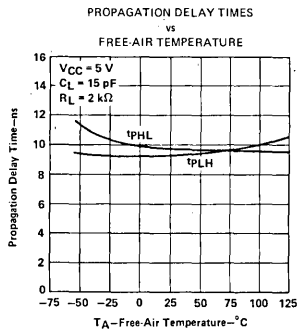

FIGURE D7

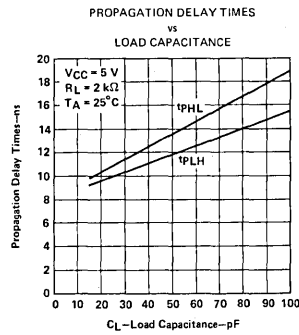

FIGURE D8

†Data for temperatures below 0°C and above 70°C are applicable for Series 54LS circuits only.

GENERAL INFORMATION 1

**SERIES 54S/74S
SCHOTTKY-CLAMPED TRANSISTOR-TRANSISTOR LOGIC**

TYPICAL CHARACTERISTICS†

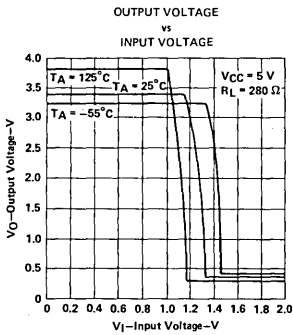

FIGURE E1

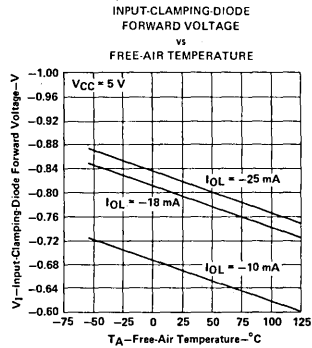

FIGURE E2

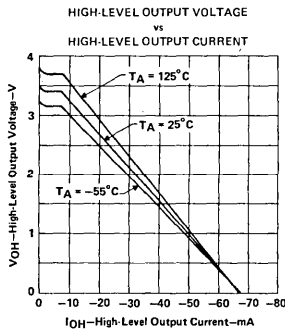

FIGURE E3

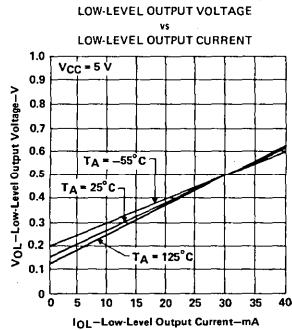

FIGURE E4

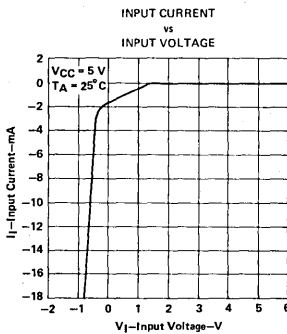

FIGURE E5

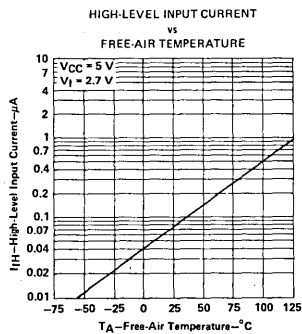
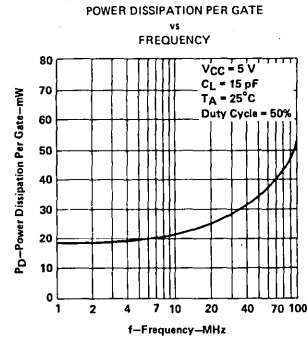
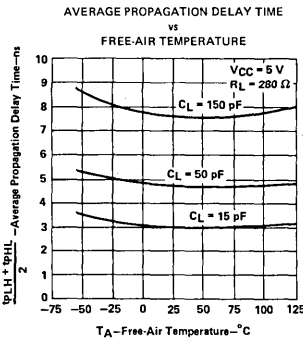
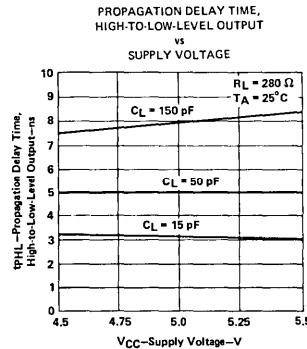
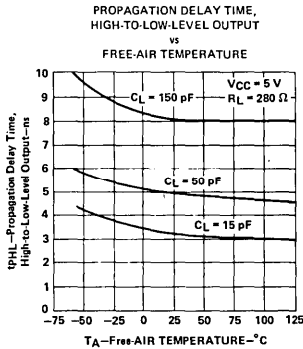
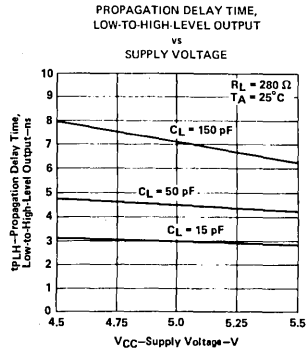
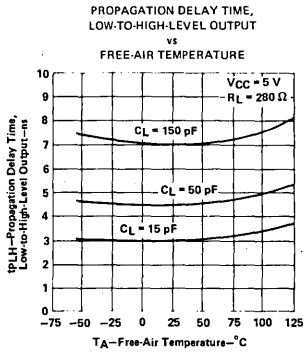

FIGURE E6

†Data for temperatures below 0°C and above 70°C are applicable for Series 54S circuits only. Data as shown are applicable specifically for the NAND gates with totem-pole outputs.

TYPICAL CHARACTERISTICS†



†Data for temperatures below 0°C and above 70°C are applicable for Series 54S circuits only.
Data as shown are applicable specifically for the NAND gates with totem-pole outputs.

1
GENERAL INFORMATION

**SERIES 54S/74S
SCHOTTKY-CLAMPED TRANSISTOR-TRANSISTOR LOGIC**

TYPICAL CHARACTERISTICS FOR FLIP-FLOPS†

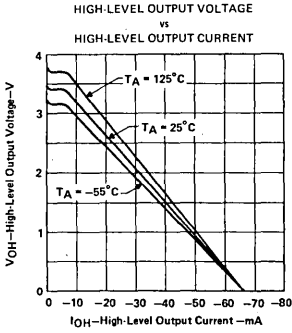

FIGURE E13

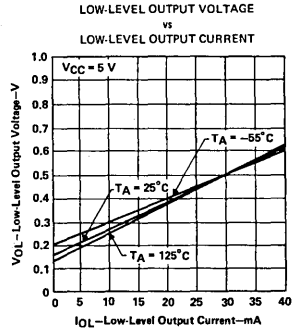

FIGURE E14

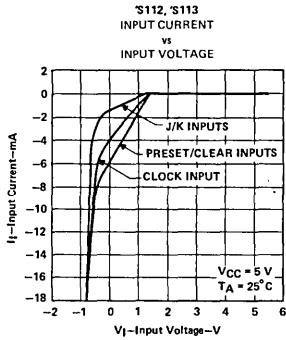

FIGURE E15

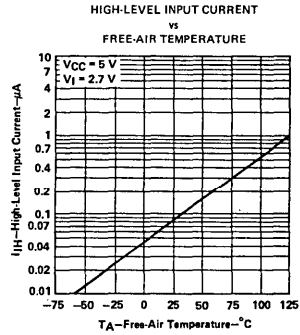

FIGURE E16

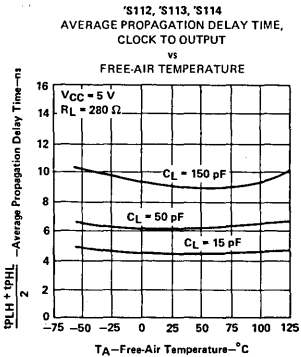

FIGURE E17

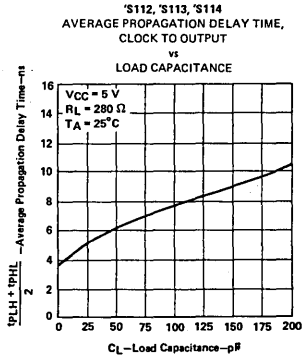

FIGURE E18

†Data for temperatures below 0°C and above 70°C are applicable for Series 54S circuits only.

General Information

1

Functional Index

2

TTL Devices

3

Mechanical Data

4

GATES AND INVERTERS

POSITIVE-NAND GATES AND INVERTERS

DESCRIPTION	TYPE	TECHNOLOGY							VOLUME
		STD TTL	ALS	AS	H	L	LS	S	
Hex 2-Input Gates	'804	●	●	B					CF
Hex Inverters	'04	●	A	●	●	●	●	●	2
	'1004	●	●	●					3
Quadruple 2-Input Gates	'00	●	A	●	●	●	●	●	2
	'1000	●	A	●					3
Triple 3-Input Gates	'10	●	A	●	●	●	●	●	2
	'1010	●	A						3S
Dual 4-Input Gates	'20	●	A	●	●	●	●	●	2
	'1020	●	A						3
8-Input Gates	'30	●	A	●	●	●	●	●	2
									3S
13-Input Gates	'133	●						●	2
Dual 2-Input Gates	'8003	●							3

POSITIVE-NAND GATES AND INVERTERS WITH OPEN-COLLECTOR OUTPUTS

DESCRIPTION	TYPE	TECHNOLOGY							VOLUME
		STD TTL	ALS	AS	H	L	LS	S	
Hex Inverters	'05	●	A		●		●	●	2
	'1005	●	●						3
Quadruple 2-Input Gates	'01	●	●		●		●	●	2
	'03	●	A			●	●	●	2
	'1003	●	A						3
Triple 3-Input Gates	'12	●	A				●	●	2
									3S
Dual 4-Input Gates	'22	●	B		●		●	●	2
									3S

POSITIVE-AND GATES

DESCRIPTION	TYPE	TECHNOLOGY							VOLUME
		STD TTL	ALS	AS	H	L	LS	S	
Hex 2-Input Gates	'808	●	●	B					CF
Quadruple 2-Input Gates	'08	●	●	●					2
	'1008	●	A	●					3
Triple 3-Input Gates	'11	●	A	●	●	●	●	●	2
	'1011	●	A						3S
Dual 4-Input Gates	'21	●	●		●	●	●	●	2
									3
Triple 4-Input AND/NAND	'800	●			▲				3

POSITIVE-AND GATES WITH OPEN-COLLECTOR OUTPUTS

DESCRIPTION	TYPE	TECHNOLOGY							VOLUME
		STD TTL	ALS	AS	H	LS	S		
Quadruple 2-Input Gates	'09	●					●	●	2
			●						3
Triple 3-Input Gates	'15	●	●	●	●	●	●	●	2
			●	A					3

POSITIVE-OR GATES

DESCRIPTION	TYPE	TECHNOLOGY							VOLUME
		STD TTL	ALS	AS	L	LS	S		
Hex 2-Input Gates	'832	●	●	B					CF
Quadruple 2-Input Gates	'32	●	●	●	●	●	●	●	2
	'1032	●	A	●					3
Triple 4-Input OR/NOR	'802	●			▲				

POSITIVE-NOR GATES

DESCRIPTION	TYPE	TECHNOLOGY							VOLUME
		STD TTL	ALS	AS	L	LS	S		
Hex 2-Input Gates	'805	●	●	B					CF
Quadruple 2-Input Gates	'02	●	●	●	●	●	●	●	2
	'1002	●	A						3
Triple 3-Input Gates	'27	●	●	●		●			2
									3
Dual 4-Input Gates with Strobe	'25	●							2
Dual 5-Input Gates	'260	●						●	

SCHMITT-TRIGGER POSITIVE-NAND GATES AND INVERTERS

DESCRIPTION	TYPE	TECHNOLOGY							VOLUME
		STD TTL	ALS	AS	L	LS	S		
Hex Inverters	'14	●					●		2
	'19	●					●		
Octal Inverters	'619	●					●		
Dual 4-Input Positive-NAND	'13	●					●		
	'18	●					●		
Triple 4-Input Positive-NAND	'618	●					●		
Quadruple 2-Input Positive-NAND	'24	●					●		
	'132	●					●		

CURRENT-SENSING GATES

DESCRIPTION	TYPE	TECHNOLOGY			VOLUME
		ALS	AS	LS	
Hex	'63			●	2

DELAY ELEMENTS

DESCRIPTION	TYP	TECHNOLOGY			VOLUME
		ALS	AS	LS	
Inverting and Noninverting Elements, 2-Input NAND Buffers	'31			●	2

CF Denotes contact factory
 ● Denotes available technology.
 ▲ Denotes planned new products.
 A Denotes "A" suffix version available in the technology indicated.
 B Denotes "B" suffix version available in the technology indicated.
 S Denotes supplement to data book.

2
Functional Index

FUNCTIONAL INDEX

GATES, EXPANDERS, BUFFERS, DRIVERS, AND TRANSCEIVERS

AND-OR-INVERT GATES

DESCRIPTION	TYPE	TECHNOLOGY						VOLUME
		STD TTL	ALS	AS	H	L	LS	
2-Wide 4-Input	'55				•	•	•	2
4-Wide 4-2-3-2 Input	'64						•	
4-Wide 2-2-3-2 Input	'54				•			
4-Wide 2-Input	'54	•						
4-Wide 2-3-3-2 Input	'54					•	•	
Dual 2-Wide 2-Input	'51	•			•	•	•	

AND-OR-INVERT GATES WITH OPEN-COLLECTOR OUTPUTS

DESCRIPTION	TYPE	TECHNOLOGY				VOLUME
		STD TTL	ALS	AS	S	
4-Wide 4-2-3-2-Input	'65				•	2

EXPANDABLE GATES

DESCRIPTION	TYPE	TECHNOLOGY						VOLUME
		STD TTL	ALS	AS	H	L	LS	
Dual 4-Input Positive-NOR With Strobe	'23	•						2
4-Wide AND-OR	'52				•			
4-Wide AND-OR-INVERT	'53	•				•		
2-Wide AND-OR-INVERT	'55					•	•	
Dual 2-Wide AND-OR-INVERT	'50	•				•	•	

EXPANDERS

DESCRIPTION	TYPE	TECHNOLOGY				VOLUME
		STD TTL	ALS	AS	H	
Dual 4-Input	'60	•				2
Triplet 3-Input	'61				•	
3-2-2-3-Input AND-OR	'62				•	

BUFFER AND INTERFACE GATES WITH OPEN-COLLECTOR OUTPUTS

DESCRIPTION	TYPE	TECHNOLOGY						VOLUME
		STD TTL	ALS	AS	LS	S		
Hex	'07	•					2	
	'17	•						
	'35		•					3S
Hex Inverter	'1035		•				3	
	'06	•					2	
	'16	•						
Quad 2-Input Positive-NAND	'1005		•				3	
	'26	•				•	2	
	'38			A,B		•		
	'39	•					2	
Quad 2-Input Positive-NOR	'1003			A			3	
	'33	•				•	2	
			A				3	

BUFFERS, DRIVERS, AND BUS TRANSCEIVERS WITH OPEN-COLLECTOR OUTPUTS

DESCRIPTION	TYPE	TECHNOLOGY						VOLUME
		STD TTL	ALS	AS	LS	S		
Noninverting Octal Buffers/Drivers	'743		▲				CF	
	'757		•	•				
	'760			•				
Inverting Octal Buffers/Drivers	'742		▲				CF	
	'756			•				
	'763			•				
Inverting and Noninverting Octal Buffers/Drivers	'762		•	•			3S	
	'759			•				
Inverting Quad Transceivers	'758			•			2	

GATES, BUFFERS, DRIVERS, AND BUS TRANSCEIVERS WITH 3-STATE OUTPUTS

DESCRIPTION	TYPE	TECHNOLOGY						VOLUME
		STD TTL	ALS	AS	LS	S		
Noninverting Octal Buffers/Drivers	'241				•	•	2	
			A	•			3	
	'244				•	•	2	
			A	•			3	
	'465				•		2	
			A				3	
	'467				•		2	
			A				3	
	'541				•		2	
			•				CF	
Inverting Octal Buffers/Drivers	'12411		•				3	
	'12441		A					
	'231		•	•			2	
	'240				•	•		
			A	•			3	
	'466				•		2	
			A				3	
	'468				•		2	
			A				3	
	'540				•		2	
		•				CF		
'12401		•				3		
Inverting and Noninverting Octal Buffers/Drivers	'230			•			3	
	'245				•		2	
Octal Transceivers	'1245		A	▲			3	
			A				3S	
Noninverting Hex Buffers/Drivers	'365	A			A		2	
	'367		•				3	
Inverting Hex Buffers/Drivers	'366	A			A		2	
	'368		▲				3	
Quad Buffers/Drivers with Independent Output Controls	'125	•			A		2	
	'126	•			A			
Noninverting Quad Transceivers	'425	•					3	
	'426	•						
	'243				•			
	'12431		A	•				
Inverting Quad Transceivers	'242				•		2	
	'12421		A,B	•			3	
Quad Transceivers with Storage	'226				•		2	
12-Input NAND Gate	'134				•		2	

50-OHM/75-OHM LINE DRIVERS

DESCRIPTION	TYPE	TECHNOLOGY				VOLUME
		STD TTL	ALS	AS	S	
Hex 2-Input Positive-NAND	'804		•	B		CF
Hex 2-Input Positive-NOR	'805		•	B		
Hex 2-Input Positive-AND	'808		•	B		
Hex 2-Input Positive-OR	'832		•	B		
Quad 2-Input Positive-NOR	'128	•				2
Dual 4-Input Positive-NAND	'140				•	

CF Denotes Contact Factory

• Denotes available technology.

▲ Denotes planned new products.

⋄ Denotes very low power.

A Denotes "A" suffix version available in the technology indicated.

S Denotes supplement to data book.

2

Functional Index

BUFFERS, DRIVERS, TRANSCEIVERS, AND CLOCK GENERATORS

BUFFERS, CLOCK/MEMORY DRIVERS

DESCRIPTION	TYPE	TECHNOLOGY					VOLUME
		STD TTL	ALS	AS	H	LS	
Hex 2-Input Positive NAND	'804		●	B			CF
Hex 2-Input Positive-NOR	'805		●	B			
Hex 2-Input Positive-AND	'808		●	B			
Hex 2-Input Positive-OR	'832		●	B			
Hex Inverter	'1004		●	●			
Hex Buffer	'34		▲				3
	'1034		●	●			
Quad 2-Input Positive-NAND	'37	●			●	●	2
	'1000		A	●			3
Quad 2-Input Positive-NOR	'28	●			●		2
	'1002		A				3
	'1036		A	●			
	'1008		A	●			
Quad 2-Input Positive-AND	'1008		A	●			
Quad 2-Input Positive-OR	'1032		A	●			
Triple 3-Input Positive-NAND	'1010		A				
Triple 3-Input Positive-AND	'1011		A				
Triple 4-Input AND-NAND	'800			▲			
Triple 4-Input OR-NOR	'802			▲			
Dual 4-Input Positive-NAND	'40	●			●	●	2
	'1020		A				3
Line Driver/Memory Driver with Series Damping Resistor	'436					●	2
Line Driver/Memory Driver	'437					●	

BI-/TRI-DIRECTIONAL BUS TRANSCEIVERS AND DRIVERS

DESCRIPTION	TYPE OF OUTPUT	TYPE	TECHNOLOGY				VOLUME
			ALS	AS	LS	S	
Quad with Bit Direction	3-State	'446		●			2
Controls	3-State	'449			●		
	OC	'440			●		
Quad Tridirection	OC	'441			●		
	3-State	'442			●		
	3-State	'443			●		
	3-State	'444			●		
4-Bit with Storage	3-State	'226			●		

OCTAL BUS TRANSCEIVERS/MOS DRIVERS

DESCRIPTION	TYPE	TECHNOLOGY					VOLUME
		STD TTL	ALS	AS	LS	S	
Inverting Outputs, 3-State	'2620		●				3
	'2640		●				
True Outputs, 3-State	'2623		●				
	'2645		●				

OCTAL BUFFERS AND LINE DRIVERS WITH INPUT/OUTPUT RESISTORS

DESCRIPTION	TYPE	TECHNOLOGY					VOLUME
		STD TTL	ALS	AS	LS	S	
Input Resistors	Inverting Outputs	'746	▲				CF
	Noninverting Outputs	'747	▲				
Output Resistors	Inverting Outputs	'2540	●				
	Noninverting Outputs	'2541	●				

CF Denotes contact factory

● Denotes available technology.

▲ Denotes planned new products.

A Denotes "A" suffix version available in the technology indicated.

S Denotes supplement to data book.

OCTAL BI-/TRI-DIRECTIONAL BUS TRANSCEIVERS

DESCRIPTION	TYPE OF OUTPUT	TYPE	TECHNOLOGY			VOLUME
			ALS	AS	LS	
12 mA 24 mA 48 mA 64 mA Sink, True Outputs	Low Power	3 State	245	A	●	3
		OC	'621	A	●	3S
		3 State	'623	A	●	3S
		OC, 3 State	'639	A	●	3
		3 State	'652	▲	●	3S
	Very Low Power	OC, 3 State	'654	▲	●	3
		OC	'1621	▲		
		3 State	'1623	▲		3
		OC, 3 State	'1639	▲		
		3 State	'620	A	●	3S
12 mA 24 mA 48 mA 64 mA Sink, Inverting Outputs	Low Power	OC	'622	A	●	3S
		OC, 3 State	'638	A	●	3
		3 State	'651	▲	●	3S
		OC, 3 State	'653	▲	●	3
		3 State	'1620	▲		
	Very Low Power	OC	'1622	▲		
		OC, 3 State	'1638	▲		3
		OC	'641	A	●	2
		3 State	'645	A	●	2
		OC	'1641	▲		
12 mA 24 mA 48 mA 64 mA Sink, Inverting Outputs	Low Power	3 State	'640	A	●	2
		OC	'642	A	●	3
	Very Low Power	3 State	'1640	A		2
		OC	'1642	▲		
		3 State	'1644	▲		3
12 mA 24 mA 48 mA 64 mA Sink, True and Inverting Outputs	Low Power	3 State	'643	A	●	2
		OC	'644	A	●	3
	Very Low Power	3 State	'1643	▲		2
		OC	'1644	▲		
		3 State	'646	▲	●	3S
Registered with Multiplexed 12 mA 24 mA 48 mA 64 mA True Outputs	3 State	3 State	'647	▲	●	3
		OC	'647	▲	●	2
	3 State	3 State	'648	▲	●	3S
		OC	'649	▲	●	2
		OC	'649	▲	●	3
Registered with Multiplexed 12 mA 24 mA 48 mA 64 mA Inverting Outputs	OC	3 State	'648	▲	●	2
		3 State	'649	▲	●	3
		3 State	'877	●	●	3S
		3 State	'852	●	●	CF
Universal Transceiver Port Controllers	3 State	3 State	'852	●	●	CF
		3 State	'856	●	●	CF

2

Functional Index

FLIP-FLOPS

DUAL AND SINGLE FLIP-FLOPS

DESCRIPTION	TYPE	TECHNOLOGY						VOLUME	
		STD TTL	ALS	AS	H	L	LS		S
Dual J K Edge Triggered	'73	●			●	●	A	2	
	'76						A		
	'78				●	●	A		
	'103				●				
	'106				●				
	'107	●					A		
	'108				●				
		●					A		
	'109		A	●					JS
	'112					A	●		2
			A	▲					3
	'113					A	●		2
			A	▲					3
	'114					A	●		2
		A	▲				3		
Single J K Edge Triggered	'70	●						2	
	'101				●				
	'102				●				
Dual Pulse Triggered	'73	●			●	●		2	
	'76	●			●	●			
	'78	●			●	●			
	'107	●			●	●			
Single Pulse Triggered	'71	●			●	●		2	
	'72	●			●	●			
	'104	●			●	●			
	'105	●			●	●			
Dual J K with Data Lockout	'111	●						3S	
Single J K with Data Lockout	'110	●							
Dual D Type	'74		A	●				3S	

QUAD AND HEX FLIP FLOPS

DESCRIPTION	NO. OF FFs	OUTPUTS	TYPE	TECHNOLOGY					VOLUME
				STD TTL	ALS	AS	LS	S	
D Type	6	Q	'174	●			●	●	2
					●	●			
							●		
	4	Q, Q̄	'171				●		2
				●			●	●	
					●	●			
J K	4	Q	'379				●	2	
					●				
					●				
					●				

OCTAL, 9-BIT, AND 10 BIT D-TYPE FLIP-FLOPS

DESCRIPTION	NO. OF BITS	OUTPUT	TYPE	TECHNOLOGY					VOLUME
				STD TTL	ALS	AS	LS	S	
True Data	Octal	3 State	'374	●	●				3
					●	●			
True Data with Clear	Octal	2 State	'273	●			●	2	
					●				
		3 State	'575	●	●				
				'874	●	●			
True with Enable	Octal	2 State	'377				●	2	
					●	●			
Inverting	Octal	3 State	'534	●	●			3	
					●	●			
				'564	●	●			
Inverting with Clear	Octal	3 State	'576	●	●			3	
				'577	●	●			
Inverting with Preset	Octal	3 State	'879	●	●			3	
				'876	●	●			
True	Octal	3 State	'825		●			CF	
Inverting	Octal	3 State	'826		●				
True	9-Bit	3 State	'823		●				
Inverting	9-Bit	3 State	'824		●				
True	10-Bit	3 State	'821		●				
Inverting	10 Bit	3 State	'822		●				

2
Functional Index

CF Denotes contact factory.
 ● Denotes available technology.
 ▲ Denotes planned new products.
 A Denotes "A" suffix version available in the technology indicated.
 B Denotes "B" suffix version available in the technology indicated.
 S Denotes supplement to data book.

LATCHES AND MULTIVIBRATORS

QUAD LATCHES

DESCRIPTION	OUTPUT	TYPE	TECHNOLOGY					VOLUME
			STD TTL	ALS	AS	LS	L	
Dual 2 Bit Transparent	2 State	'75	●				● ●	2
	2 State	'77	●				● ●	
S R	2 State	'375					●	
	2 State	'279	●				A	

RETRIGGERABLE MONOSTABLE MULTIVIBRATORS

DESCRIPTION	TYPE	TECHNOLOGY					VOLUME
		STD TTL	ALS	AS	LS	L	
Single		'122	●			● ●	2
		'130	●				
		'422				● ●	
Dual		'123	●			● ●	
		'423				● ●	

D-TYPE

OCTAL, 9-BIT, AND 10-BIT RAD-BACK LATCHES

DESCRIPTION	NO. OF BITS	TYPE	TECHNOLOGY					VOLUME
			STD TTL	ALS	AS	LS	S	
Edge Triggered Inverting and Noninverting	Octal	'996		▲				5
	Octal	'990		▲				
Transparent True	9 Bit	'992		▲				
	10 Bit	'994		▲				
	Octal	'991		▲				
Transparent Noninverting	9 Bit	'992		▲				
	10 Bit	'994		▲				
	Octal	'666		▲				
Transparent with Clear True Outputs	Octal	'667		▲				

OCTAL, 9-BIT, AND 10-BIT LATCHES

DESCRIPTION	NO. OF BITS	OUTPUT	TYPE	TECHNOLOGY					VOLUME
				STD TTL	ALS	AS	LS	S	
Transparent	Octal	3-State	'288					● ●	2
			'373					● ●	
			'573			● ●			3
			'100	●					
Dual 4-Bit Transparent	Octal	2-State	'116	●					2
			'873			● ●			
			'533			● ●			
Inverting Transparent	Octal	3-State	'563			● ●		3	
			'580			● ●			
			'880			● ●			
Dual 4-Bit Inverting Transparent	Octal	3-State	'604				●	2	
			OC	'605					●
			3-State	'606					●
			OC	'607					●
Addressable	Octal	2-State	'259	●			●	3	
			'412				●		
Multi-Mode Buffered	Octal	3-State	'845			● ●		3	
True	Octal	3-State	'845			● ●			
Inverting	Octal	3-State	'846			● ●			
True	9 Bit	3-State	'843			● ●			
Inverting	9 Bit	3-State	'844			● ●			
True	10 Bit	3-State	'841			● ●			
Inverting	10 Bit	3-State	'842			● ●			

MONOSTABLE MULTIVIBRATORS WITH SCHMITT-TRIGGER INPUTS

DESCRIPTION	TYPE	TECHNOLOGY					VOLUME	
		STD TTL	ALS	AS	LS	S		
Single		'121	●				●	2
Dual		'221	●			●		

CF Denotes contact factory.
 ● Denotes available technology.
 ▲ Denotes planned new products.
 S Denotes supplement to data book.

2
 Functional Index

REGISTERS

SHIFT REGISTERS

DESCRIPTION	NO. OF BITS	MODES				TYPE	TECHNOLOGY					VOLUME		
		SR	TS	LOAD	HOLD		STD TTL	ALS	AS	L	LS		S	
Sign Protected		X	X	X	X	'322					A		2	
Parallel In, Parallel Out, Bidirectional	8	X	X	X	X	'198	•							2
		X	X	X	X	'299		•	▲			•	•	3
		X	X	X	X	'323		•	▲			•		2
Parallel In, Parallel Out, Registered Outputs	4	X	X	X	X	'194	•				A	•	2	
		X	X	X	X	'671			▲			•	3	
Parallel In, Parallel Out	4	X	X	X	X	'672						•	2	
		8	X	X	X	X	'199	•						
		5	X	X	X	X	'96	•				•	•	2
		X	X	X		'95	A					•	B	3S
		X	X	X		'99						•		
		X	X	X	X	'178	•							2
		X	X	X	X	'179	•							
		X	X	X		'195	•					A	•	2
Serial In, Parallel Out	8	X	X			'295			▲				3	
		X	X			'395					B		2	
		X	X			'673					A	•	3	
Parallel In, Serial Out	8	X	X	X	X	'674					•		2	
		X	X	X	X	'165	•					A		
Serial In, Serial Out	8	X	X	X	X	'166	•		▲			A	3	
		X	X	X	X	'91	A					•	•	
Serial In, Serial Out	4	X	X	X		'94	•						2	

SHIFT REGISTERS WITH LATCHES

DESCRIPTION	NO. OF BITS	OUTPUTS	TYPE	TECHNOLOGY			VOLUME
				ALS	AS	LS	
Parallel-In, Parallel-Out with Output Latches	4	3 State	'671			•	2
		3 State	'672			•	
Serial-In, Parallel-Out with Output Latches	8	2 State	'673			•	2
		Buffered	'594			•	
		3 State	'595			•	
		OC	'596			•	
Parallel-In, Serial-Out, with Input Latches	8	2 State	'597			•	2
		3 State	'589			•	
Parallel I/O Ports with Input Latches, Multiplexed Serial Inputs	8	3 State	'598			•	2

SIGN-PROTECTED REGISTERS

DESCRIPTION	NO. OF BITS	MODES				TYPE	TECHNOLOGY			VOLUME		
		SR	TS	LOAD	HOLD		ALS	AS	LS			
Sign-Protected Register	8	X	X	X	X	'322				A		2

REGISTER FILES

DESCRIPTION	OUTPUT	TYPE	TECHNOLOGY				VOLUME
			STD TTL	ALS	AS	LS	
8 Words x 2 Bits	3 State	'172	•				2
4 Words x 4 Bits	OC	'170	•			•	
Dual 16 Words x 4 Bits	3 State	'670				•	3
	3 State	'870				▲	
	3 State	'871				▲	

OTHER REGISTERS

DESCRIPTION	TYPE	TECHNOLOGY					VOLUME	
		STD TTL	ALS	AS	L	LS		S
Quadruple Multiplexers with Storage	'98						2	
	'298	•				•	3S	
	'398					•		
	'399					•	2	
8 Bit Universal Shift Registers	'299					•	•	3
Quadruple Bus Buffer Registers	'173	•				A		2
Octal Storage Register	'396						•	

- Denotes available technology.
- ▲ Denotes planned new products.
- A Denotes "A" suffix version available in the technology indicated.
- B Denotes "B" suffix version available in the technology indicated.
- S Denotes supplement to data book.

COUNTERS

SYNCHRONOUS COUNTERS - POSITIVE-EDGE TRIGGERED

DESCRIPTION	PARALLEL LOAD	TYPE	TECHNOLOGY					VOLUME	
			STD TTL	ALS	AS	L	LS		S
Decade	Sync	'160	•				A		2
				B	•				CF
	Sync	'162	•				A	•	2
				P	•				CF
	Sync	'560	A						3
								•	
Sync	'668					•			
Sync	'690					•			
Sync	'692					•			
Decade Up Down	Sync	'168		B	•			•	3S
			•				•		2
	Async	'190			•				3
			•			•	•		2
	Sync	'568	A						3
								•	
Sync	'696					•			
Sync	'698					•			
Decade Rate Multiplier, $\frac{1}{N10}$	Async Set to 9	'167	•						2
							A		CF
4 Bit Binary	Sync	'163	•	B	•				2
							A	•	2
	Sync	'561	A		B	•			CF
	Sync	'669						•	2
								•	
Sync	'691						•		
							•		
Sync	'693						•		
						B	•		3S
4 Bit Binary Up Down	Async	'191	•				•		2
					•				3
	Async	'193				•	•		2
			•						3
Sync	'569	A						2	
							•		
Sync	'697						•		
							•		
Sync	'699					•			
6 Bit Binary Rate Multiplier, $\frac{1}{N2}$	Async CLR	'867	•						3
8 Bit Up Down	Sync CLR	'869							3
			•						

ASYNCHRONOUS COUNTERS (RIPPLE CLOCK) - NEGATIVE EDGE TRIGGERED

DESCRIPTION	PARALLEL LOAD	TYPE	TECHNOLOGY					VOLUME			
			STD TTL	ALS	AS	L	LS		S		
Decade	Set to 9	'90	A				•	•		2	
								•			
	Yes	'176	•						•		
									•		•
4 Bit Binary	Set to 9	'290	•					•		2	
								•	•		
	None	'93	A					•			
								•	•		
	Yes	'177		•							
											•
None	'293							•			
									•	•	
Divide by 12	None	'92	A								
Dual Decade	None	'390	•								
									•	•	
Dual 4 Bit Binary	None	'393	•								
									•	•	

8 BIT BINARY COUNTERS WITH REGISTERS

DESCRIPTION	TYPE OF OUTPUT	TYPE	TECHNOLOGY			VOLUME
			ALS	AS	LS	
Parallel Register Outputs	3 State	'590				2
			OC	'591		
Parallel Register Inputs	2 State	'592				
Parallel I/O	3 State	'593				

FREQUENCY DIVIDERS, RATE MULTIPLIERS

DESCRIPTION	TYPE	TECHNOLOGY			VOLUME	
		STD TTL	ALS	AS		LS
50 to 1 Frequency Divider		'56				2
60 to 1 Frequency Divider		'57			•	
60 Bit Binary Rate Multiplier		'97	•			
Decade Rate Multiplier...		'167	•			

- CF Denotes contact factory.
- Denotes available technology.
- ▲ Denotes planned new products.
- A Denotes "A" suffix version available in the technology indicated.
- B Denotes "B" suffix version available in the technology indicated.
- S Denotes supplement to data book.

2
Functional Index



DECODERS, ENCODERS, DATA SELECTORS/MULTIPLEXERS AND SHIFTERS

DATA SELECTORS/MULTIPLEXERS

DESCRIPTION	TYPE OF OUTPUT	TYPE	STD TTL	TECHNOLOGY					VOLUME
				ALS	AS	L	LS	S	
16 To 1	2 State	'150	●						2
	3 State	'250		●					3S
	3 State	'850		●					
	3 State	'851		●					
Dual 8 To 1	3 State	'351	●						2
		A				●	●		
8 To 1	2 State	'151		●	●				3S
	2 State	'152	A				●		2
	3 State	'251	●				●	●	3
	3 State	'354			▲			●	2
	2 State	'355					●		
	3 State	'356					●		
	OC	'357						●	
Dual 4 To 1	2 State	'153	●		●	●	●		3
	3 State	'253		●	●			●	2
				●	●				3
	2 State	'352		●	●			●	2
	3 State	'353		●	●			●	3
Octal 2 To 1 with Storage	3 State	'604						●	2
	OC	'605						●	
	3 State	'606						●	
	OC	'607						●	
Quad 2 To 1 with Storage	2 State	'98			●				2
	2 State	'298	●				●		3S
	2 State	'398						●	2
2 State	'399						●		
Quad 2 To 1	2 State	'157	●		●	●	●		3
				●	●			●	2
	2 State	'158		●	●			●	3
	3 State	'257		●	●			B ●	2
	3 State	'258		A ●			B ●		CF
6 to 1 Universal Multiplexer	3 State	'857		●	●				3

DECODERS/DEMULTIPLEXERS

DESCRIPTION	TYPE OF OUTPUT	TYPE	STD TTL	TECHNOLOGY					VOLUME
				ALS	AS	L	LS	S	
4 To 16	3 State	'154	●			●			2
	OC	'159	●						
4 To 10 BCD To Decimal	2 State	'42	A			●	●		3
4 To 10 Excess 3-To-Decimal	2 State	'43	A			●			
4 To 10 Excess 3-Gray-To-Decimal	2 State	'44	A			●			
3 To 8 with Address Latches	2 State	'131		●	▲				
3 To 8	2 State	'137		●	▲				2
				●	▲			●	3
Dual 2 To 4	2 State	'138		●	▲				2
	3 State	'538		▲				● ●	3
Dual 1-To-4 Decoders	2 State	'139		▲	●			A ●	2
	OC	'155	●					A ●	
	3 State	'156	●					●	3
	3 State	'539		▲					3

CODE CONVERTERS

DESCRIPTION	TYPE	TECHNOLOGY			VOLUME
		STD TTL	S		
6 Line BCD to 6 Line Binary, Or 4 Line to 4 Line BCD 9's/BCD 10's Converters	'184	●			2
6 Bit Binary to 6 Bit BCD Converters	'185	A			
BCD to Binary Converters	'484			A	4
Binary to BCD Converters	'485			A	

PRIORITY ENCODERS/REGISTERS

DESCRIPTION	TYPE	TECHNOLOGY				VOLUME
		STD TTL	ALS	AS	LS	
Full BCD	'147	●			●	2
Cascadable Octal	'148	●			●	
Cascadable Octal with 3 State Outputs	'348				●	
4 Bit Cascadable with Registers	'278	●				

SHIFTERS

DESCRIPTION	OUTPUT	TYPE	STD TTL	TECHNOLOGY					VOLUME
				ALS	AS	L	LS	S	
4 Bit Shifter	3 State	'350						●	2
Parallel 16 Bit Multi-Mode Barrel Shifter	3 State	'897			▲				5

2

Functional Index

CF Denotes contact factory.
 ● Denotes available technology.
 ▲ Denotes planned new products.
 A Denotes "A" suffix version available in the technology indicated.
 B Denotes "B" suffix version available in the technology indicated.
 S Denotes supplement to data book.

DISPLAY DECODERS/DRIVERS, MEMORY/MICROPROCESSOR CONTROLLERS, AND VOLTAGE-CONTROLLED OSCILLATORS

OPEN COLLECTOR DISPLAY DECODERS /DRIVERS

DESCRIPTION	OFF-STATE OUTPUT VOLTAGE	TYPE	TECHNOLOGY				VOLUME
			STD TTL	ALS	AS	L LS	
BCD To Decimal	30 V	'45	●				2
	60 V	'141	●				
	15 V	'145	●			●	
	7 V	'445				●	
BCD To Seven Segment	30 V	'46	A			●	2
	15 V	'47	A			●	
	5.5 V	'48	●			●	
	5.5 V	'49	●			●	
	30 V	'246	●			●	
	15 V	'247	●			●	
	7 V	'347				●	
	7 V	'447				●	
	5.5 V	'248	●			●	
	5.5 V	'249	●			●	

OPEN COLLECTOR DISPLAY DECODERS/DRIVERS WITH COUNTERS/LATCH

DESCRIPTION	TYPE	TECHNOLOGY			VOLUME
		STD TTL	ALS	AS	
BCD Counter/4 Bit Latch/BCD To Decimal Decoder/Driver	'142	●			2
BCD Counter/4 Bit Latch/BCD-To Seven Segment Decoder/Lad Driver	'143	●			
BCD Counter/4 Bit Latch/BCD-To Seven Segment Decoder/Lamp Driver	'144	●			

VOLTAGE-CONTROLLED OSCILLATORS

No. VCOs	DESCRIPTION					TECHNOLOGY			VOLUME
	COMP'L Z _{OUT}	ENABLE	RANGE INPUT	R _{EXT}	f _{max} MHz	TYPE	LS	S	
Single	Yes	Yes	Yes	No	20	'624	●		2
Single	Yes	Yes	Yes	Yes	20	'628	●		
Dual	No	Yes	Yes	No	60	'124		●	
Dual	Yes	Yes	No	No	20	'626	●		
Dual	No	No	No	No	20	'627	●		
Dual	No	Yes	Yes	No	20	'629	●		

MEMORY MICROPROCESSOR CONTROLLERS

DESCRIPTION	TYPE	TECHNOLOGY					VOLUME
		ALS	AS	LS	S		
System Controllers, Universal or For 8088	890		▲				5
Memory Refresh Controllers	Transparent	4K, 16K	600			A	2
	Burst Modes	64K	601			A	
	Cycle Steal	4K, 16K	602			A	
	Burst Modes	64K	603			A	
Memory Cycle Controller			608			●	2
Memory Mappers	3 State		612			●	
	OC		613			●	
Memory Mappers With Output Latches	3 State		610			●	
	OC		611			●	
Multi Mode Latches (8080A Applications)			412			●	

CLOCK GENERATOR CIRCUITS

DESCRIPTION	TYPE	TECHNOLOGY					VOLUME
		STD TTL	ALS	AS	LS	S	
Quadruple Complementary Output Logic Elements	'265	●					2
Dual Pulse Synchronizers Drivers	'120	●					
Crystal Controlled Oscillators	'320				●		
	'321				●		
Digital Phase Lock Loop	'297				●		
Programmable Frequency Dividers Digital Timers	'292				●		
'294					●		
Triple 4 Input AND NAND Drivers	'800				▲		3
Triple 4 Input OR NOR Drivers	802				▲		
Dual VCO	'124					●	

2
Functional Index

RESULTANT DISPLAYS USING '46A, '47A, '48, '49, 'L46, 'L47, 'LS47, 'LS48, 'LS49, 'LS347

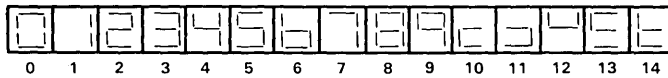

RESULTANT DISPLAYS USING '246, '247, '248, '249, 'LS247, 'LS248, 'LS249, 'LS447

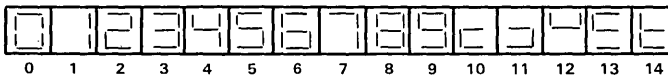

RESULTANT DISPLAYS USING '143, '144



- Denotes available technology.
- ▲ Denotes planned new products.
- A Denotes "A" suffix version available in the technology indicated.

FUNCTIONAL INDEX

COMPARATORS AND ERROR DETECTION CIRCUITS

4-BIT COMPARATORS

DESCRIPTION					TYPE	TECHNOLOGY					VOLUME	
P=Q	P>Q	P<Q	OUTPUT ENABLE	STD TTL		ALS	AS	L	LS	S		
Yes	Yes	No	2 State	No	'85	•			•	•	•	2

8-BIT COMPARATORS

DESCRIPTION					TYPE	TECHNOLOGY			VOLUME		
INPUTS	P=Q	P>Q	P<Q	OUTPUT ENABLE		ALS	AS	LS			
20 kΩ Pull-Up	Yes	No	No	OC	Yes	'518	•		3		
	No	Yes	No	2 State	Yes	'520	•				
	No	Yes	No	OC	Yes	'522	•				
	Yes	No	Yes	2 State	No	'682			2		
	Yes	No	Yes	OC	No	'683					
	Standard	Yes	No	No	OC	Yes	'519	•		3	
No		Yes	No	2 State	Yes	'521	•				
Yes		No	Yes	2 State	No	'684					
Yes		No	Yes	OC	No	'685			2		
Yes		No	Yes	2 State	Yes	'686					
Yes		No	Yes	OC	Yes	'687					
No		Yes	No	2 State	Yes	'688	•		3		
No		Yes	No	OC	Yes	'689	•		2		
Latched P and Q		No	No	Yes	Yes	2 State	Yes	'895		•	3
Latched P and Q		Yes	No	Yes	Yes	Latched	Yes	'866		•	2

ADDRESS COMPARATORS

DESCRIPTION	OUTPUT ENABLE	LATCHED OUTPUT	TYPE	TECHNOLOGY		VOLUME
				ALS	AS	
16-Bit to 4-Bit	Yes			'677	•	3S
		Yes		'678	•	
12-Bit to 4-Bit	Yes			'679	•	
		Yes		'680	•	

PARITY GENERATORS/CHECKERS, ERROR DETECTION AND CORRECTION CIRCUITS

DESCRIPTION	NO. OF BITS	TYPE	TECHNOLOGY					VOLUME		
			STD TTL	ALS	AS	LS	S			
Odd/Even Parity Generators/Checkers	8	'180	•					•	•	2
	9	'280		•	▲					3
	9	'286								3
Parallel Error Detection/Correction Circuits	3-State OC	8	'636					•		2
	OC	8	'637					•		
	3-State OC	16	'616		▲	•				5
	OC	16	'617		▲					
	3-State OC	16	'630					•		2
	OC	16	'631					•		
	3-State OC	32	'632		A					CF
	OC	32	'633		▲					
3-State OC	32	'634		▲						
OC	32	'635		▲						

FUSE PROGRAMMABLE COMPARATORS

DESCRIPTION	TYPE	TECHNOLOGY					VOLUME
		STD TTL	ALS	AS	LS	S	
16-Bit Identity Comparator	'526		▲				3
12-Bit Identity Comparator	'528		▲				
8-Bit Identity Comparator	'527		▲				
and 4-Bit Comparator							

2 Functional Index

- CF Denotes contact factory.
- Denotes available technology.
- ▲ Denotes planned new products.
- S Denotes supplement to data book.

ARITHMETIC CIRCUITS AND PROCESSOR ELEMENTS

PARALLEL BINARY ADDERS

DESCRIPTION	TYPE	TECHNOLOGY						VOLUME
		STD TTL	ALS	AS	H	LS	S	
1-Bit Gated	'80	●						2
2-Bit	'82	●						
4-Bit	'83	A				A		
Dual 1-Bit Carry Save	'283	●				●	●	
	'183					●	●	

ACCUMULATORS, ARITHMETIC LOGIC UNITS,
LOOK-AHEAD CARRY GENERATORS

DESCRIPTION	TYPE	TECHNOLOGY						VOLUME
		STD TTL	ALS	AS	LS	S		
4-Bit parallel Binary Accumulators	'281					●	2	
	'81					●		
4-Bit Arithmetic Logic Units/ Function Generators	'181	●				●	3	
	'381			A		●		
	'81				A	●		
4-Bit Arithmetic Logic Unit with Ripple Carry	'382					●	2	
	'182	●				●		
Look Ahead Carry Generators	16 Bit	'282		▲			3	
	32 Bit	'882				●		
Quad Serial Adder/Subtractor	'385					●	2	
8 Bit Slice Elements	'888			▲			5	

MULTIPLIERS

DESCRIPTION	TYPE	TECHNOLOGY						VOLUME
		STD TTL	ALS	AS	LS	S		
2-Bit by-4-Bit Parallel Binary Multipliers	'261					●	2	
4-Bit by 4-Bit Parallel Binary Multipliers	'284	●						
	'285	●						
25-MHz 6-Bit Binary Rate Multipliers	'97	●						
25-MHz Decade Rate Multipliers	'167	●						
8-Bit x 1-Bit 2's Complement Multipliers	'384					●		
16-Bit Multimode Multiplier	'1616		▲				5	

OTHER ARITHMETIC OPERATORS

DESCRIPTION	TYPE	TECHNOLOGY								VOLUME
		STD TTL	ALS	AS	H	L	LS	S		
Quad 2-Input Exclusive-OR Gates with Totem-Pole Outputs	'86	●					●	A	●	2
	'386		●						A	
Quad 2-Input Exclusive-OR Gates with Open-Collector Outputs	'136	●							●	2
	'266		●						●	
Quad 2-Input Exclusive-NOR Gates	'810		●	▲						3S
	'811		●	▲						
Quad Exclusive-OR/NOR Gates	'135								●	2
	'87					●				

BIPOLAR BIT-SLICE PROCESSOR ELEMENTS

DESCRIPTION	CASCADABLE TO N-BITS	TYPE	TECHNOLOGY					VOLUME
			ALS	AS	LS	S		
8-Bit Slice	Yes	'888		●				5

- Denotes available-technology.
- ▲ Denotes planned new products.
- A Denotes "A" suffix version available in the technology indicated.
- S Denotes supplement to data book.

2
Functional Index

MEMORIES

USER-PROGRAMMABLE READ-ONLY MEMORIES (PROM's)
STANDARD PROM's

DESCRIPTION	TYPE	ORGANIZATION	TYPE OUTPUT	S	VOLUME
16K-Bit Arrays	TBP28S166	2048W × 8B	3-State	●	4
	TBP38S165	2048W × 8B	3-State	▲	
	TBP38S166	2048W × 8B	3-State	▲	
	TBP38SA165	2048W × 8B	OC	▲	
	TBP38SA166	2048W × 8B	OC	▲	
	TBP34S162	4096W × 4B	3-State	▲	
8K-Bit Arrays	TBP24S81	2048W × 4B	3-State	●	4
	TBP24SA81	2048W × 4B	OC	▲	
	TBP28S85A	1024W × 8B	3-State	●	
	TBP28S86A	1024W × 8B	3-State	●	
	TBP28SA86A	1024W × 8B	OC	●	
	TBP38S85	1024W × 8B	3-State	▲	
4K-Bit Arrays	TBP24S41	1024W × 4B	3-State	●	4
	TBP24SA41	1024W × 4B	OC	●	
	TBP28S42	512W × 8B	3-State	●	
	TBP28SA42	512W × 8B	OC	●	
	TBP28S46	512W × 8B	3-State	●	
	TBP28SA46	512W × 8B	OC	●	
2K-Bit Arrays	TBP38S22	256W × 8B	3-State	▲	4
	TBP38SA22	256W × 8B	OC	▲	
1K-Bit Arrays	TBP24S10	256W × 4B	3-State	●	4
	TBP24SA10	256W × 4B	OC	●	
	TBP34S10	256W × 4B	3-State	●	
	TBP34SA10	256W × 4B	OC	●	
256-Bit Arrays	TBP18S030	32W × 8B	3-State	●	4
	TBP18SA030	32W × 8B	OC	●	
	TBP38S030	32W × 8B	3-State	●	
	TBP38SA030	32W × 8B	OC	●	

LOW-POWER PROM's

DESCRIPTION	TYPE	ORGANIZATION	TYPE OUTPUT	S	VOLUME
16K-Bit Arrays	TBP28L166	2048W × 8B	3-State	●	4
	TBP38L165	2048W × 8B	3-State	●	
	TBP38L166	2048W × 8B	3-State	●	
	TBP34L162	4096W × 4B	3-State	▲	
8K-Bit Arrays	TBP28L85A	1024W × 8B	3-State	▲	4
	TBP28L86A	1024W × 8B	3-State	●	
	TBP38L85	1024W × 8B	3-State	▲	
	TBP38L86	1024W × 8B	3-State	▲	
4K-Bit Arrays	TBP28L42	512W × 8B	3-State	●	4
	TBP28L46	512W × 8B	3-State	●	
2K-Bit Arrays	TBP28L22	256W × 8B	3-State	●	4
	TBP28LA22	256W × 8B	OC	●	
	TBP38L22	256W × 8B	3-State	▲	
1K-Bit Arrays	TBP34L10	256W × 4B	3-State	▲	4
256-Bit Arrays	TBP38L030	32W × 8B	3-State	▲	4

REGISTERED PROM's

DESCRIPTION	TYPE	ORGANIZATION	TYPE OUTPUT	S	VOLUME
16K-Bit Arrays	TBP34R162	4096W × 4B	3-State	▲	4
	TBP34SR165	4096W × 4B	3-State	▲	

RANDOM ACCESS READ-WRITE MEMORIES (RAM's)

DESCRIPTION	ORGANIZATION	TYPE OF OUTPUT	TYPE	TECHNOLOGY					VOLUME
				STD TTL	ALS	AS	LS	S	
256-Bit Arrays	256 × 1	3-State	'201					●	4
		OC	'301					●	
64-Bit Arrays	16 × 4	3-State	'89	●					4
		3-State	'189				A B		
		3-State	'219				A		
		OC	'289				A B		
16-Bit Multiple-Port Register File	8 × 2	3-State	'172	●					2
		OC	'170	●				●	
16-Bit Register File	4 × 4	3-State	'670					●	3
		3-State	'870					●	
Dual 64-Bit Register Files	16 × 4	3-State	'871					●	3
		3-State	'971					●	

FIRST-IN FIRST-OUT MEMORIES (FIFO'S)

DESCRIPTION	TYPE OF OUTPUT	TYPE	TECHNOLOGY				VOLUME
			ALS	AS	LS	LS	
16 Words × 5 Bits	3-State	'225				●	5
64 Words × 5 Bits	3-State	'233	▲				
64 Words × 4 Bits	3-State	'232	▲				

- Denotes available technology.
- ▲ Denotes planned new products.
- A Denotes "A" suffix version available in the technology indicated.
- B Denotes "B" suffix version available in the technology indicated.

2 Functional Index

PROGRAMMABLE LOGIC ARRAYS

PROGRAMMABLE LOGIC ARRAYS

DESCRIPTION	INPUTS	OUTPUTS		TYPE NO	ALS	NO. OF PINS	VOLUME
		NO.	TYPE				
Impact PAL [®] Circuits	16	8	Active-Low	*PAL16L8-15	●	20	4
		4		*PAL16R4-15	●		
		6	Registered	*PAL16R6-15	●		
		8		*PAL16R8-15	●		
Half-Power Impact Circuits	16	8	Active-low	*PAL16L8-25	●	20	
		4		*PAL16R4-25	●		
		6	Registered	*PAL16R6-25	●		
		8		*PAL16R8-25	●		
High-Performance PAL [®] Circuits	16	8	Active-Low	*PAL16L8A	●	20	
		4		*PAL16R4A	●		
		6	Registered	*PAL16R6A	●		
		8		*PAL16R8A	●		
Half-Power PAL [®] Circuits	16	8	Active-Low	*PAL16R8A-2	●	20	
		4		*PAL16R4A-2	●		
		6	Registered	*PAL16R6A-2	●		
		8		*PAL16R8A-2	●		
High-Performance PAL [®] Circuits	20	8	Active-Low	*PAL20L8A	▲	24	
		4		*PAL20R4A	▲		
		6	Registered	*PAL20R6A	▲		
		8		*PAL20R8A	▲		
Half-Power PAL [®] Circuits	20	8	Active-Low	*PAL20L8A-2	▲	24	
		4		*PAL20R4A-2	▲		
		6	Registered	*PAL20R6A-2	▲		
		8		*PAL20R8A-2	▲		
Exclusive-OR PAL [®] Circuits	20	10	Active-Low	*PAL20L10-20	▲	24	
		4		*PAL20X4-20	▲		
		8	Registered	*PAL20X8-20	▲		
		10		*PAL20X10-20	▲		
Exclusive-OR PAL [®] Circuits	20	8	Active-Low	*PALR19L8-35	▲	24	
		4		*PAL20X4-35	▲		
		8	Registered	*PAL20X8-35	▲		
		10		*PAL20X10-35	▲		
Registered-Input PAL [®] Circuits	19	8	Active-Low	*PALR19L8-25	▲	24	
		4		*PALR19R4-25	▲		
		6	Registered	*PALR19R6-25	▲		
		8		*PALR19R8-25	▲		
Registered-Input PAL [®] Circuits	19	8	Active-Low	*PALR19L8-40	▲	24	
		4		*PALR19R4-40	▲		
		6	Registered	*PALR19R6-40	▲		
		8		*PALR19R8-40	▲		
Latched-Input PAL [®] Circuits	19	8	Active-Low	*PALT19L8-25	▲	24	
		4		*PALT19R4-25	▲		
		6	Registered	*PALT19R6-25	▲		
		8		*PALT19R8-25	▲		
Latched-Input PAL [®] Circuits	19	8	Active-Low	*PALT19L8-40	▲	24	
		4		*PALT19R4-40	▲		
		6	Registered	*PALT19R6-40	▲		
		8		*PALT19R8-40	▲		
Field-Programmable 14x32x6 Logic Arrays	14	6	3-State	FPLA839	●	24	
		6	OC	FPLA840	●		

*PAL is a registered trademark of Monolithic Memories Incorporated.

- Denotes available technology.
- ▲ Denotes planned new products.

2

FUNCTIONAL INDEX

General Information

1

Functional Index

2

TTL Devices

3

Mechanical Data

4

3

TTL DEVICES

TYPES SN5400, SN54H00, SN54L00, SN54LS00, SN54S00, SN7400, SN74H00, SN74LS00, SN74S00 QUADRUPLE 2-INPUT POSITIVE-NAND GATES

REVISED DECEMBER 1983

- Package Options Include Both Plastic and Ceramic Chip Carriers in Addition to Plastic and Ceramic DIPs
- Dependable Texas Instruments Quality and Reliability

description

These devices contain four independent 2-input NAND gates.

The SN5400, SN54H00, SN54L00, and SN54LS00, and SN54S00 are characterized for operation over the full military temperature range of -55°C to 125°C . The SN7400, SN74H00, SN74LS00, and SN74S00 are characterized for operation from 0°C to 70°C .

FUNCTION TABLE (each gate)

INPUTS		OUTPUT
A	B	Y
H	H	L
L	X	H
X	L	H

logic diagram (each gate)



positive logic

$$Y = \overline{A \cdot B} \text{ or } Y = \overline{A} + \overline{B}$$

SN5400, SN54H00, SN54L00 ... J PACKAGE
SN54LS00, SN54S00 ... J OR W PACKAGE
SN7400, SN74H00 ... J OR N PACKAGE
SN74LS00, SN74S00 ... D, J OR N PACKAGE

(TOP VIEW)

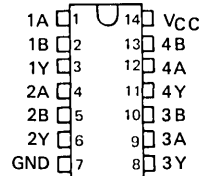

SN5400, SN54H00 ... W PACKAGE

(TOP VIEW)

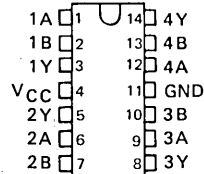

SN54LS00, SN54S00 ... FK PACKAGE
SN74LS00, SN74S00 ... FN PACKAGE

(TOP VIEW)

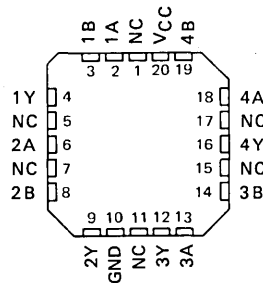

NC - No internal connection

3

TTL DEVICES

PRODUCTION DATA

This document contains information current as of publication date. Products conform to specifications per the terms of Texas Instruments standard warranty. Production processing does not necessarily include testing of all parameters.

TEXAS
INSTRUMENTS

POST OFFICE BOX 225012 • DALLAS, TEXAS 75265

TYPES SN5400, SN7400
QUADRUPLE 2-INPUT POSITIVE-NAND GATES

recommended operating conditions

	SN5400			SN7400			UNIT
	MIN	NOM	MAX	MIN	NOM	MAX	
V _{CC} Supply voltage	4.5	5	5.5	4.75	5	5.25	V
V _{IH} High-level input voltage	2			2			V
V _{IL} Low-level input voltage	0.8			0.8			V
I _{OH} High-level output current	-0.4			-0.4			mA
I _{OL} Low-level output current	16			16			mA
T _A Operating free-air temperature	-55 125			0 70			°C

electrical characteristics over recommended operating free-air temperature range (unless otherwise noted)

PARAMETER	TEST CONDITIONS †	SN5400			SN7400			UNIT
		MIN	TYP ‡	MAX	MIN	TYP ‡	MAX	
V _{IK}	V _{CC} = MIN, I _I = -12 mA	-1.5			-1.5			V
V _{OH}	V _{CC} = MIN, V _{IL} = 0.8 V, I _{OH} = -0.4 mA	2.4	3.4		2.4	3.4		V
V _{OL}	V _{CC} = MIN, V _{IH} = 2 V, I _{OL} = 16 mA	0.2 0.4		0.2 0.4			V	
I _I	V _{CC} = MAX, V _I = 5.5 V	1			1			mA
I _{IH}	V _{CC} = MAX, V _I = 2.4 V	40			40			μA
I _{IL}	V _{CC} = MAX, V _I = 0.4 V	-1.6			-1.6			mA
I _{OS} §	V _{CC} = MAX	-20		-55	-18		-55	mA
I _{CCH}	V _{CC} = MAX, V _I = 0 V	4 8		4 8			mA	
I _{CCL}	V _{CC} = MAX, V _I = 4.5 V	12 22		12 22			mA	

† For conditions shown as MIN or MAX, use the appropriate value specified under recommended operating conditions.

‡ All typical values are at V_{CC} = 5 V, T_A = 25°C.

§ Not more than one output should be shorted at a time.

switching characteristics, V_{CC} = 5 V, T_A = 25°C (see note 2)

PARAMETER	FROM (INPUT)	TO (OUTPUT)	TEST CONDITIONS		MIN	TYP	MAX	UNIT
t _{PLH}	A or B	Y	R _L = 400 Ω,	C _L = 15 pF		11	22	ns
t _{PHL}						7	15	ns

NOTE 2: See General Information Section for load circuits and voltage waveforms.

3

TTL DEVICES

TYPES SN54H00, SN74H00

QUADRUPLE 2-INPUT POSITIVE-NAND GATES

recommended operating conditions

	SN54H00			SN74H00			UNIT
	MIN	NOM	MAX	MIN	NOM	MAX	
V _{CC} Supply voltage	4.5	5	5.5	4.75	5	5.25	V
V _{IH} High-level input voltage	2			2			V
V _{IL} Low-level input voltage			0.8			0.8	V
I _{OH} High-level output current			-0.5			-0.5	mA
I _{OL} Low-level output current			20			20	mA
T _A Operating free-air temperature	-55		125	0		70	°C

electrical characteristics over recommended operating free-air temperature range (unless otherwise noted)

PARAMETER	TEST CONDITIONS †	MIN	TYP ‡	MAX	UNIT
V _{IK}	V _{CC} = MIN, I _I = -8 mA			-1.5	V
V _{OH}	V _{CC} = MIN, V _{IL} = 0.8 V, I _{OH} = -0.5 mA	2.4	3.5		V
V _{OL}	V _{CC} = MIN, V _{IH} = 2 V, I _{OL} = 20 mA		0.2	0.4	V
I _I	V _{CC} = MAX, V _I = 5.5 V			1	mA
I _{IH}	V _{CC} = MAX, V _I = 2.4 V			50	μA
I _{IL}	V _{CC} = MAX, V _I = 0.4 V			-2	mA
I _{OS} §	V _{CC} = MAX	-40		-100	mA
I _{CCH}	V _{CC} = MAX, V _I = 0 V		10	16.8	mA
I _{CCL}	V _{CC} = MAX, V _I = 4.5 V		26	40	mA

† For conditions shown as MIN or MAX, use the appropriate value specified under recommended operating conditions.

‡ All typical values are at V_{CC} = 5 V, T_A = 25°C.

§ Not more than one output should be shorted at a time, and the duration of the short-circuit should not exceed one second.

switching characteristics, V_{CC} = 5 V, T_A = 25°C (see note 2)

PARAMETER	FROM (INPUT)	TO (OUTPUT)	TEST CONDITIONS	MIN	TYP	MAX	UNIT
t _{PLH}	A or B	Y	R _L = 280 Ω, C _L = 25 pF		5.9	10	ns
t _{PHL}					6.2	10	ns

NOTE 2: See General Information Section for load circuits and voltage waveforms.

3

TTL DEVICES

TYPE SN54L00
QUADRUPLE 2-INPUT POSITIVE-NAND GATES

recommended operating conditions

	SN54L00			UNIT
	MIN	NOM	MAX	
V _{CC} Supply voltage	4.5	5	5.5	V
V _{IH} High-level input voltage	2			V
V _{IL} Low-level input voltage			0.7	V
I _{OH} High-level output current			-0.1	mA
I _{OL} Low-level output current			2	mA
T _A Operating free-air temperature	-55		125	°C

electrical characteristics over recommended operating free-air temperature range (unless otherwise noted)

PARAMETER	TEST CONDITIONS †	SN54L00			UNIT
		MIN	TYP ‡	MAX	
V _{OH}	V _{CC} = MIN, V _{IL} = 0.7 V, I _{OH} = -0.1 mA	2.4	3.3		V
V _{OL}	V _{CC} = MIN, V _{IH} = 2 V, I _{OL} = 2 mA		0.15	0.3	V
I _I	V _{CC} = MAX, V _I = 5.5 V			0.1	mA
I _{IH}	V _{CC} = MAX, V _I = 2.4 V			10	µA
I _{IL}	V _{CC} = MAX, V _I = 0.3 V			-0.18	mA
I _{OS} §	V _{CC} = MAX	-3		-15	mA
I _{CCH}	V _{CC} = MAX, V _I = 0 V		0.44	0.8	mA
I _{CCL}	V _{CC} = MAX, V _I = 4.5 V		1.16	2.04	mA

† For conditions shown as MIN or MAX, use the appropriate value specified under recommended operating conditions.

‡ All typical values are at V_{CC} = 5 V, T_A = 25°C.

§ Not more than one output should be shorted at a time.

switching characteristics, V_{CC} = 5 V, T_A = 25°C (see note 2)

PARAMETER	FROM (INPUT)	TO (OUTPUT)	TEST CONDITIONS	MIN	TYP	MAX	UNIT
t _{PLH}	A or B	Y	R _L = 4 kΩ, C _L = 50 pF		35	60	ns
t _{PHL}					31	60	ns

NOTE 2: See General Information Section for load circuits and voltage waveforms.

3

TTL DEVICES

TYPES SN54LS00, SN74LS00

QUADRUPLE 2-INPUT POSITIVE-NAND GATES

recommended operating conditions

	SN54LS00			SN74LS00			UNIT
	MIN	NOM	MAX	MIN	NOM	MAX	
V _{CC} Supply voltage	4.5	5	5.5	4.75	5	5.25	V
V _{IH} High-level input voltage	2			2			V
V _{IL} Low-level input voltage			0.7			0.8	V
I _{OH} High-level output current			-0.4			-0.4	mA
I _{OL} Low-level output current			4			8	mA
T _A Operating free-air temperature	-55		125	0		70	°C

electrical characteristics over recommended operating free-air temperature range (unless otherwise noted)

PARAMETER	TEST CONDITIONS †	SN54LS00		SN74LS00		UNIT		
		MIN	TYP‡	MAX	MIN		TYP‡	MAX
V _{IK}	V _{CC} = MIN, I _I = -18 mA			-1.5		-1.5	V	
V _{OH}	V _{CC} = MIN, V _{IL} = MAX, I _{OH} = -0.4 mA	2.5	3.4		2.7	3.4	V	
V _{OL}	V _{CC} = MIN, V _{IH} = 2 V, I _{OL} = 4 mA		0.25	0.4		0.25	0.4	V
	V _{CC} = MIN, V _{IH} = 2 V, I _{OL} = 8 mA					0.35	0.5	
I _I	V _{CC} = MAX, V _I = 7 V			0.1		0.1	mA	
I _{IH}	V _{CC} = MAX, V _I = 2.7 V			20		20	μA	
I _{IL}	V _{CC} = MAX, V _I = 0.4 V			-0.4		-0.4	mA	
I _{OS} §	V _{CC} = MAX	-20		-100	-20	-100	mA	
I _{CCH}	V _{CC} = MAX, V _I = 0 V		0.8	1.6		0.8	1.6	mA
I _{CCL}	V _{CC} = MAX, V _I = 4.5 V		2.4	4.4		2.4	4.4	mA

† For conditions shown as MIN or MAX, use the appropriate value specified under recommended operating conditions.

‡ All typical values are at V_{CC} = 5 V, T_A = 25°C

§ Not more than one output should be shorted at a time, and the duration of the short-circuit should not exceed one second.

switching characteristics, V_{CC} = 5 V, T_A = 25°C (see note 2)

PARAMETER	FROM (INPUT)	TO (OUTPUT)	TEST CONDITIONS	MIN	TYP	MAX	UNIT
t _{PLH}	A or B	Y	R _L = 2 kΩ, C _L = 15 pF		9	15	ns
t _{PHL}					10	15	ns

NOTE 2: See General Information Section for load circuits and voltage waveforms.

TYPES SN54S00, SN74S00 QUADRUPLE 2-INPUT POSITIVE-NAND GATES

recommended operating conditions

	SN54S00			SN74S00			UNIT
	MIN	NOM	MAX	MIN	NOM	MAX	
V _{CC} Supply voltage	4.5	5	5.5	4.75	5	5.25	V
V _{IH} High-level input voltage	2			2			V
V _{IL} Low-level input voltage	0.8			0.8			V
I _{OH} High-level output current	-1			-1			mA
I _{OL} Low-level output current	20			20			mA
T _A Operating free-air temperature	-55			0			70 °C

electrical characteristics over recommended operating free-air temperature range (unless otherwise noted)

PARAMETER	TEST CONDITIONS †	SN54S00			SN74S00			UNIT
		MIN	TYP‡	MAX	MIN	TYP‡	MAX	
V _{IK}	V _{CC} = MIN, I _I = -18 mA	-1.2			-1.2			V
V _{OH}	V _{CC} = MIN, V _{IL} = 0.8 V, I _{OH} = -1 mA	2.5	3.4		2.7	3.4		V
V _{OL}	V _{CC} = MIN, V _{IH} = 2 V, I _{OL} = 20 mA	0.5			0.5			V
I _I	V _{CC} = MAX, V _I = 5.5 V	1			1			mA
I _{IH}	V _{CC} = MAX, V _I = 2.7 V	50			50			µA
I _{IL}	V _{CC} = MAX, V _I = 0.5 V	-2			-2			mA
I _{OS} §	V _{CC} = MAX	-40	-100		-40	-100		mA
I _{CCH}	V _{CC} = MAX, V _I = 0 V	10 16			10 16			mA
I _{CCL}	V _{CC} = MAX, V _I = 4.5 V	20 36			20 36			mA

† For conditions shown as MIN or MAX, use the appropriate value specified under recommended operating conditions.

‡ All typical values are at V_{CC} = 5 V, T_A = 25°C.

§ Not more than one output should be shorted at a time, and the duration of the short-circuit should not exceed one second.

switching characteristics, V_{CC} = 5 V, T_A = 25°C (see note 2)

PARAMETER	FROM (INPUT)	TO (OUTPUT)	TEST CONDITIONS	MIN	TYP	MAX	UNIT
t _{PLH}	A or B	Y	R _L = 280 Ω, C _L = 15 pF	3	4.5		ns
t _{PHL}				3	5		ns
t _{PLH}			R _L = 280 Ω, C _L = 50 pF	4.5			ns
t _{PHL}				5			ns

NOTE 2: See General Information Section for load circuits and voltage waveforms.

3
TTL DEVICES

TYPES SN5401, SN54H01, SN54LS01, SN7401, SN74H01, SN74LS01 QUADRUPLE 2-INPUT POSITIVE-NAND GATES WITH OPEN-COLLECTOR OUTPUTS

REVISED APRIL 1985

- Package Options Include both Plastic and Ceramic Chip Carriers in Addition to Plastic and Ceramic DIPs
- Dependable Texas Instruments Quality and Reliability

description

These devices contain four independent 2-input-NAND gates. The open-collector outputs require pull-up resistors to perform correctly. They may be connected to other open-collector outputs to implement active-low wired-OR or active-high wired-AND functions. Open-collector devices are often used to generate higher V_{OH} levels.

The SN5401, SN54H01, and SN54LS01 are characterized for operation over the full military temperature ranges of -55°C to 125°C . The SN7401, SN74H01, and SN74LS01 are characterized for operation from 0°C to 70°C .

FUNCTION TABLE (each gate)

INPUTS		OUTPUT
A	B	Y
H	H	L
L	X	H
X	L	H

logic diagram (each gate)



positive logic

$$Y = \overline{A \cdot B} \text{ or } Y = \overline{A} + \overline{B}$$

SN5401 ... J PACKAGE
SN54LS01 ... J OR W PACKAGE
SN7401 ... J OR N PACKAGE
SN74LS01 ... D, J OR N PACKAGE

(TOP VIEW)

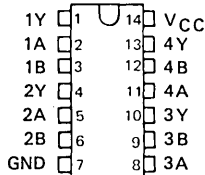

SN5401, SN54H01 ... W PACKAGE

(TOP VIEW)

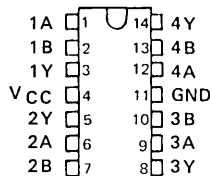

SN54H01 ... J PACKAGE
SN74H01 ... J OR N PACKAGE

(TOP VIEW)

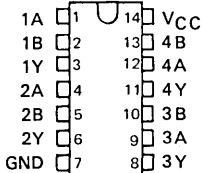

SN54LS01 ... FK PACKAGE
SN74LS01 ... FN PACKAGE

(TOP VIEW)

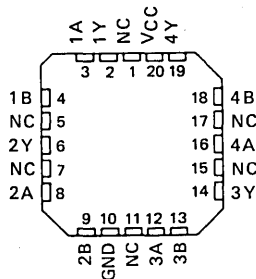

NC - No internal connection



TTL DEVICES

PRODUCTION DATA
This document contains information current as of publication date. Products conform to specifications per the terms of Texas Instruments standard warranty. Production processing does not necessarily include testing of all parameters.



POST OFFICE BOX 225012 • DALLAS, TEXAS 75265

**TYPES SN5401, SN54H01, SN54LS01,
SN7401, SN74H01, SN74LS01
QUADRUPLE 2-INPUT POSITIVE-NAND GATES WITH OPEN-COLLECTOR OUTPUTS**

schematics (each gate)

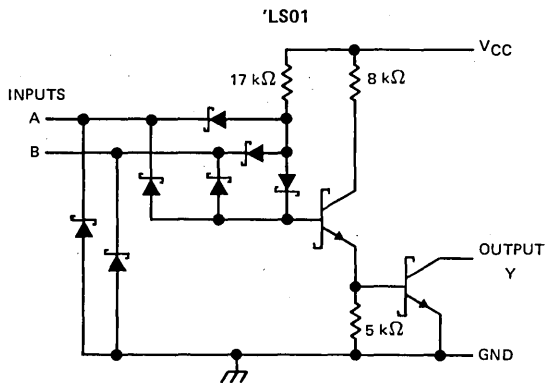
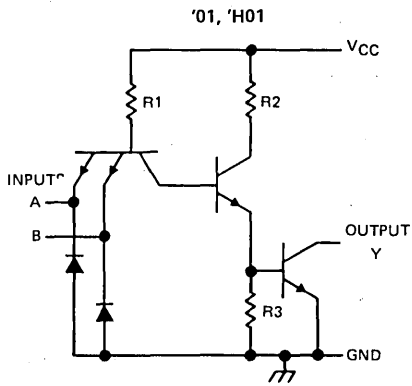

CIRCUITS	R1	R2	R3
'01	4 kΩ	1.6 kΩ	1 kΩ
'H01	2.8 kΩ	760 Ω	470 Ω

Resistor values shown are nominal.

3 TTL DEVICES

absolute maximum ratings over operating free-air temperature (unless otherwise noted)

Supply voltage, V_{CC} (see Note 1): '01, 'H01, 'LS01	7 V
Input voltage: '01, 'H01	5.5 V
'LS01	7 V
Off-state output voltage	7 V
Operating free-air temperature range: SN54'	-55°C to 125°C
SN74'	0°C to 70°C
Storage temperature range	-65°C to 150°C

NOTE-1: Voltage values are with respect to network ground terminal.

TYPES SN5401, SN7401

QUADRUPLE 2-INPUT POSITIVE-NAND GATES WITH OPEN-COLLECTOR OUTPUTS

recommended operating conditions

	SN5401			SN7401			UNIT		
	MIN	NOM	MAX	MIN	NOM	MAX			
V_{CC} Supply voltage	4.5	5	5.5	4.75	5	5.25	V		
V_{IH} High-level input voltage	2			2			V		
V_{IL} Low-level input voltage	0.8			0.8			V		
V_{OH} High-level output voltage	5.5			5.5			V		
I_{OL} Low-level output current	16			16			mA		
T_A Operating free-air temperature	- 55			125			0	70	°C

electrical characteristics over recommended operating free-air temperature range (unless otherwise noted)

PARAMETER	TEST CONDITIONS†	MIN	TYP‡	MAX	UNIT
V_{IK}	$V_{CC} = \text{MIN}$, $I_I = -12 \text{ mA}$			- 1.5	V
I_{OH}	$V_{CC} = \text{MIN}$, $V_{IL} = 0.8 \text{ V}$, $V_{OH} = 5.5 \text{ V}$			0.25	mA
V_{OL}	$V_{CC} = \text{MIN}$, $V_{IH} = 2 \text{ V}$, $I_{OL} = 16 \text{ mA}$		0.2	0.4	V
I_I	$V_{CC} = \text{MAX}$, $V_I = 5.5 \text{ V}$			1	mA
I_{IH}	$V_{CC} = \text{MAX}$, $V_I = 2.4 \text{ V}$			40	μA
I_{IL}	$V_{CC} = \text{MAX}$, $V_I = 0.4 \text{ V}$			- 1.6	mA
I_{CCH}	$V_{CC} = \text{MAX}$, $V_I = 0 \text{ V}$		4	8	mA
I_{CCL}	$V_{CC} = \text{MAX}$, $V_I = 4.5 \text{ V}$		12	22	mA

† For conditions shown as MIN or MAX, use the appropriate value specified under recommended operating conditions.
 ‡ All typical values are at $V_{CC} = 5 \text{ V}$, $T_A = 25^\circ\text{C}$.

switching characteristics, $V_{CC} = 5 \text{ V}$, $T_A = 25^\circ\text{C}$ (see note 2)

PARAMETER	FROM (INPUT)	TO (OUTPUT)	TEST CONDITIONS	MIN	TYP	MAX	UNIT
t_{PLH}	A or B	Y	$R_L = 4 \text{ k}\Omega$, $C_L = 15 \text{ pF}$	35		55	ns
t_{PHL}			$R_L = 400 \Omega$, $C_L = 15 \text{ pF}$	8		15	ns

NOTE 2: See General Information Section for load circuits and voltage waveforms.

3

TTL DEVICES

TYPES SN54H01, SN74H01

QUADRUPLE 2-INPUT POSITIVE-NAND GATES WITH OPEN-COLLECTOR OUTPUTS

recommended operating conditions

	SN54H01			SN74H01			UNIT
	MIN	NOM	MAX	MIN	NOM	MAX	
V _{CC} Supply voltage	4.5	5	5.5	4.75	5	5.25	V
V _{IH} High-level input voltage	2			2			V
V _{IL} Low-level input voltage	0.8			0.8			V
V _{OH} High-level output voltage	5.5			5.5			V
I _{OL} Low-level output current	20			20			mA
T _A Operating free-air temperature	- 55		125	0		70	°C

electrical characteristics over recommended operating free-air temperature range (unless otherwise noted)

PARAMETER	TEST CONDITIONS†	MIN	TYP‡	MAX	UNIT
V _{IK}	V _{CC} = MIN, I _I = -8 mA			-1.5	V
I _{OH}	V _{CC} = MIN, V _{IL} = 0.8 V, V _{OH} = 5.5 V			0.25	mA
V _{OL}	V _{CC} = MIN, V _{IH} = 2 V, I _{OL} = 20 mA		0.2	0.4	V
I _I	V _{CC} = MAX, V _I = 5.5 V			1	mA
I _{IH}	V _{CC} = MAX, V _I = 2.4 V			50	μA
I _{IL}	V _{CC} = MAX, V _I = 0.4 V			-2	mA
I _{CCH}	V _{CC} = MAX, V _I = 0 V		10	16.8	mA
I _{CCL}	V _{CC} = MAX, V _I = 4.5 V		26	40	mA

† For conditions shown as MIN or MAX, use the appropriate value specified under recommended operating conditions.

‡ All typical values are at V_{CC} = 5 V, T_A = 25°C.

switching characteristics, V_{CC} = 5 V, T_A = 25°C (see note 2)

PARAMETER	FROM (INPUT)	TO (OUTPUT)	TEST CONDITIONS	MIN	TYP	MAX	UNIT
t _{PLH}	A or B	Y	R _L = 280 Ω, C _L = 25 pF		10	15	ns
t _{PHL}					7.5	12	ns

NOTE 2: See General Information Section for load circuits and voltage waveforms.

TYPES SN54LS01, SN74LS01

QUADRUPLE 2-INPUT POSITIVE-NAND GATES WITH OPEN-COLLECTOR OUTPUTS

recommended operating conditions

	SN54LS01			SN74LS01			UNIT
	MIN	NOM	MAX	MIN	NOM	MAX	
V_{CC} Supply voltage	4.5	5	5.5	4.75	5	5.25	V
V_{IH} High-level input voltage	2			2			V
V_{IL} Low-level input voltage	0.7			0.8			V
V_{OH} High-level output voltage	5.5			5.5			V
I_{OL} Low-level output current	4			8			mA
T_A Operating free-air temperature	-55 125			0 70			°C

electrical characteristics over recommended operating free-air temperature range (unless otherwise noted)

PARAMETER	TEST CONDITIONS †	SN54LS01			SN74LS01			UNIT
		MIN	TYP ‡	MAX	MIN	TYP ‡	MAX	
V_{IK}	$V_{CC} = \text{MIN}, I_I = -18 \text{ mA}$	-1.5			-1.5			V
I_{OH}	$V_{CC} = \text{MIN}, V_{IL} = \text{MAX}, V_{OH} = 5.5 \text{ V}$	0.1			0.1			mA
V_{OL}	$V_{CC} = \text{MIN}, V_{IH} = 2 \text{ V}, I_{OL} = 4 \text{ mA}$	0.25	0.4		0.25	0.4	V	
	$V_{CC} = \text{MIN}, V_{IH} = 2 \text{ V}, I_{OL} = 8 \text{ mA}$				0.35	0.5		
I_I	$V_{CC} = \text{MAX}, V_I = 7 \text{ V}$	0.1			0.1			mA
I_{IH}	$V_{CC} = \text{MAX}, V_I = 2.7 \text{ V}$	20			20			μA
I_{IL}	$V_{CC} = \text{MAX}, V_I = 0.4 \text{ V}$	-0.4			-0.4			mA
I_{CCH}	$V_{CC} = \text{MAX}, V_I = 0 \text{ V}$	0.8	1.6		0.8	1.6	mA	
I_{CCL}	$V_{CC} = \text{MAX}, V_I = 4.5 \text{ V}$	2.4	4.4		2.4	4.4	mA	

† For conditions shown as MIN or MAX, use the appropriate value specified under recommended operating conditions.

‡ All typical values are at $V_{CC} = 5 \text{ V}, T_A = 25^\circ\text{C}$.

switching characteristics, $V_{CC} = 5 \text{ V}, T_A = 25^\circ\text{C}$ (see note 2)

PARAMETER	FROM (INPUT)	TO (OUTPUT)	TEST CONDITIONS		MIN	TYP	MAX	UNIT
t_{PLH}	A or B	Y	$R_L = 2 \text{ k}\Omega,$	$C_L = 15 \text{ pF}$	17	32		ns
t_{PHL}					15	28		ns

NOTE 2: See General Information Section for load circuits and voltage waveforms.

3

TTL DEVICES



TTL DEVICES

TYPES SN5402, SN54L02, SN54LS02, SN54S02, SN7402, SN74LS02, SN74S02 QUADRUPLE 2-INPUT POSITIVE-NOR GATES

REVISED DECEMBER 1983

- Package Options Include Both Plastic and Ceramic Chip Carriers in Addition to Plastic and Ceramic DIPs
- Dependable Texas Instruments Quality and Reliability

description

These devices contain four independent 2-input-NOR gates.

The SN5402, SN54L02, SN54LS02 and SN54S02 are characterized for operation over the full military temperature range of -55°C to 125°C . The SN7402, SN74LS02 and SN74S02 are characterized for operation from 0°C to 70°C .

FUNCTION TABLE (each gate)

INPUTS		OUTPUT
A	B	Y
H	X	L
X	H	L
L	L	H

logic diagram (each gate)



positive logic

$$Y = \overline{A \cdot B} \text{ or } Y = \overline{A + B}$$

SN5402, SN54L02 ... J PACKAGE
SN54LS02, SN54S02 ... J OR W PACKAGE
SN7402 ... J OR N PACKAGE
SN74LS02, SN74S02 ... D, J OR N PACKAGE
(TOP VIEW)

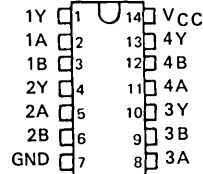

SN5402 ... W PACKAGE
(TOP VIEW)

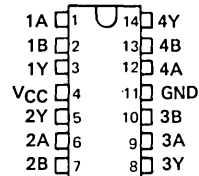

SN54LS02, SN54S02 ... FK PACKAGE
SN74LS02, SN74S02 ... FN PACKAGE
(TOP VIEW)

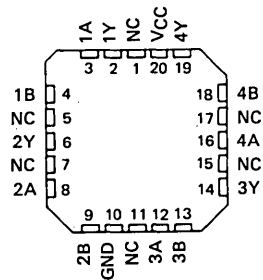

NC - No internal connection

3

TTL DEVICES

PRODUCTION DATA
This document contains information current as of publication date. Products conform to specifications per the terms of Texas Instruments standard warranty. Production processing does not necessarily include testing of all parameters.

TEXAS INSTRUMENTS
POST OFFICE BOX 225012 • DALLAS, TEXAS 75265

**TYPES SN5402, SN54L02, SN54LS02, SN54S02,
SN7402, SN74LS02, SN74S02
QUADRUPLE 2-INPUT POSITIVE-NOR GATES**

schematics (each gate)

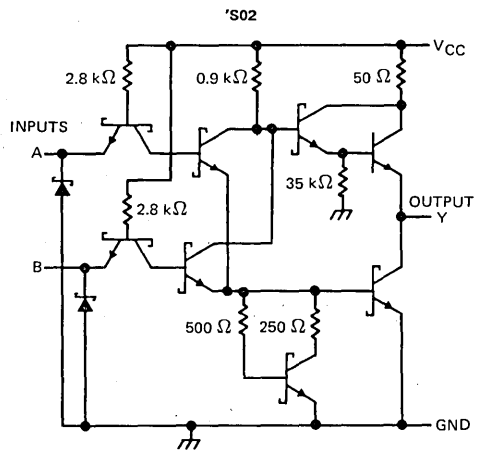
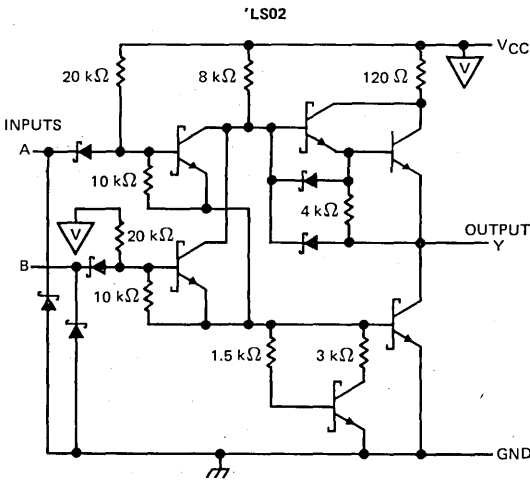
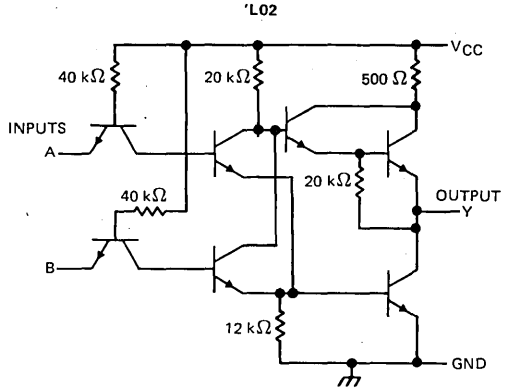
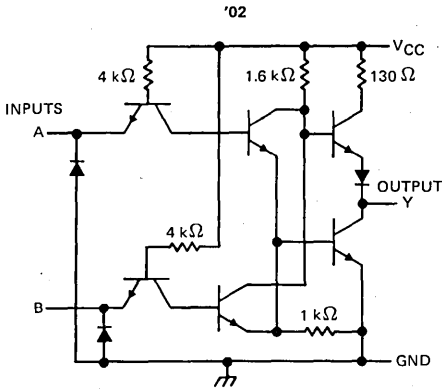

Resistor values shown are nominal.

absolute maximum ratings over operating free-air temperature range (unless otherwise noted)

Supply voltage, V_{CC} (see Note 1):	'02, 'LS02, 'S02	7 V
	'L02	8 V
Input voltage:	'02, 'L02, 'S02	5.5 V
	'LS02	7 V
Off-state output voltage		7 V
Operating free-air temperature range:	SN54'	-55°C to 125°C
	SN74'	0°C to 70°C
Storage temperature range		-65°C to 150°C

NOTE 1: Voltage values are with respect to network ground terminal.

3 TTL DEVICES

TYPES SN5402, SN7402
QUADRUPLE 2-INPUT POSITIVE-NOR GATES

recommended operating conditions

	SN5402			SN7402			UNIT
	MIN	NOM	MAX	MIN	NOM	MAX	
V _{CC} Supply voltage	4.5	5	5.5	4.75	5	5.25	V
V _{IH} High-level input voltage	2			2			V
V _{IL} Low-level input voltage				0.8			V
I _{OH} High-level output current				-0.4			mA
I _{OL} Low-level output current				16			mA
T _A Operating free-air temperature	-55			125			0 70 °C

electrical characteristics over recommended operating free-air temperature range (unless otherwise noted)

PARAMETER	TEST CONDITIONS †	SN5402			SN7402			UNIT
		MIN	TYP ‡	MAX	MIN	TYP ‡	MAX	
V _{IK}	V _{CC} = MIN, I _I = -12 mA	-1.5			-1.5			V
V _{OH}	V _{CC} = MIN, V _{IL} = 0.8 V, I _{OH} = -0.4 mA	2.4	3.4		2.4	3.4		V
V _{OL}	V _{CC} = MIN, V _{IH} = 2 V, I _{OL} = 16 mA		0.2	0.4		0.2	0.4	V
I _I	V _{CC} = MAX, V _I = 5.5 V	1			1			mA
I _{IH}	V _{CC} = MAX, V _I = 2.4 V	40			40			µA
I _{IL}	V _{CC} = MAX, V _I = 0.4 V	-1.6			-1.6			mA
I _{OS} §	V _{CC} = MAX	-20		-55	-18		-55	mA
I _{CCH}	V _{CC} = MAX, V _I = 0 V		8	16		8	16	mA
I _{CCL}	V _{CC} = MAX, See Note 2		14	27		14	27	mA

† For conditions shown as MIN or MAX, use the appropriate value specified under recommended operating conditions.

‡ All typical values are at V_{CC} = 5 V, T_A = 25°C.

§ Not more than one output should be shorted at a time.

NOTE 2: One input at 4.5 V, all others at GND.

switching characteristics, V_{CC} = 5 V, T_A = 25°C (see note 3)

PARAMETER	FROM (INPUT)	TO (OUTPUT)	TEST CONDITIONS		MIN	TYP	MAX	UNIT
t _{PLH}	A or B	Y	R _L = 400 Ω,	C _L = 15 pF		12	22	ns
t _{PHL}						8	15	ns

NOTE 3: See General Information Section for load circuits and voltage waveforms.

3

TTL DEVICES

TYPE SN54L02 QUADRUPLE 2-INPUT POSITIVE-NOR GATES

recommended operating conditions

	SN54L02			UNIT
	MIN	NOM	MAX	
V _{CC} Supply voltage	4.5	5	5.5	V
V _{IH} High-level input voltage	2			V
V _{IL} Low-level input voltage			0.7	V
I _{OH} High-level output current			-0.1	mA
I _{OL} Low-level output current		2		mA
T _A Operating free-air temperature	-55		125	°C

electrical characteristics over recommended operating free-air temperature range (unless otherwise noted)

PARAMETER	TEST CONDITIONS †	SN54L02			UNIT
		MIN	TYP ‡	MAX	
V _{OH}	V _{CC} = MIN, V _{IL} = 0.7 V, I _{OH} = -0.1 mA	2.4	3.3		V
V _{OL}	V _{CC} = MIN, V _{IH} = 2 V, I _{OL} = 2 mA		0.15	0.3	V
I _I	V _{CC} = MAX, V _I = 5.5 V			0.1	mA
I _{IH}	V _{CC} = MAX, V _I = 2.4 V			10	μA
I _{IL}	V _{CC} = MAX, V _I = 0.3 V			-0.18	mA
I _{OS} §	V _{CC} = MAX	-3		-15	mA
I _{CCH}	V _{CC} = MAX, V _I = 0 V		0.8	1.6	mA
I _{CCL}	V _{CC} = MAX, See Note 2		1.4	2.6	mA

† For conditions shown as MIN or MAX, use the appropriate value specified under recommended operating conditions.

‡ All typical values are at V_{CC} = 5 V, T_A = 25°C.

§ Not more than one output should be shorted at a time.

NOTE 2: One input at 4.5 V, all others at GND.

switching characteristics, V_{CC} = 5 V, T_A = 25°C (see note 3)

PARAMETER	FROM (INPUT)	TO (OUTPUT)	TEST CONDITIONS	MIN	TYP	MAX	UNIT
t _{PLH}	A or B	Y	R _L = 4 kΩ, C _L = 50 pF		31	60	ns
t _{PHL}					35	60	ns

NOTE 3: See General Information Section for load circuits and voltage waveforms.

TYPES SN54LS02, SN74LS02 QUADRUPLE 2-INPUT POSITIVE-NOR GATES

recommended operating conditions

	SN54LS02			SN74LS02			UNIT
	MIN	NOM	MAX	MIN	NOM	MAX	
V_{CC} Supply voltage	4.5	5	5.5	4.75	5	5.25	V
V_{IH} High-level input voltage	2			2			V
V_{IL} Low-level input voltage	0.7			0.8			V
I_{OH} High-level output current	-0.4			-0.4			mA
I_{OL} Low-level output current	4			8			mA
T_A Operating free-air temperature	-55 125			0 70			°C

electrical characteristics over recommended operating free-air temperature range (unless otherwise noted)

PARAMETER	TEST CONDITIONS †	SN54LS02			SN74LS02			UNIT
		MIN	TYP‡	MAX	MIN	TYP‡	MAX	
V_{IK}	$V_{CC} = \text{MIN}, I_I = -18 \text{ mA}$	-1.5			-1.5			V
V_{OH}	$V_{CC} = \text{MIN}, V_{IL} = \text{MAX}, I_{OH} = -0.4 \text{ mA}$	2.5	3.4		2.7	3.4		V
V_{OL}	$V_{CC} = \text{MIN}, V_{IH} = 2 \text{ V}, I_{OL} = 4 \text{ mA}$	0.25	0.4		0.25	0.4		V
	$V_{CC} = \text{MIN}, V_{IH} = 2 \text{ V}, I_{OL} = 8 \text{ mA}$				0.35	0.5		
I_I	$V_{CC} = \text{MAX}, V_I = 7 \text{ V}$	0.1			0.1			mA
I_{IH}	$V_{CC} = \text{MAX}, V_I = 2.7 \text{ V}$	20			20			µA
I_{IL}	$V_{CC} = \text{MAX}, V_I = 0.4 \text{ V}$	-0.4			-0.4			mA
$I_{OS}§$	$V_{CC} = \text{MAX}$	-20	-100		-20	-100		mA
I_{CCH}	$V_{CC} = \text{MAX}, V_I = 0 \text{ V}$	1.6	3.2		1.6	3.2		mA
I_{CCL}	$V_{CC} = \text{MAX}, \text{ See Note 2}$	2.8	5.4		2.8	5.4		mA

† For conditions shown as MIN or MAX, use the appropriate value specified under recommended operating conditions.

‡ All typical values are at $V_{CC} = 5 \text{ V}, T_A = 25^\circ\text{C}$

§ Not more than one output should be shorted at a time, and the duration of the short-circuit should not exceed one second.

NOTE 2: One input at 4.5 V, all others at GND.

switching characteristics, $V_{CC} = 5 \text{ V}, T_A = 25^\circ\text{C}$ (see note 3)

PARAMETER	FROM (INPUT)	TO (OUTPUT)	TEST CONDITIONS		MIN	TYP	MAX	UNIT
t_{PLH}	A or B	Y	$R_L = 2 \text{ k}\Omega,$	$C_L = 15 \text{ pF}$	10	15		ns
t_{PHL}					10	15		ns

NOTE 3: See General Information Section for load circuits and voltage waveforms.

3

TTL DEVICES

TYPES SN54S02, SN74S02

QUADRUPLE 2-INPUT POSITIVE-NOR GATES

recommended operating conditions

	SN54S02			SN74S02			UNIT
	MIN	NOM	MAX	MIN	NOM	MAX	
V _{CC} Supply voltage	4.5	5	5.5	4.75	5	5.25	V
V _{IH} High-level input voltage	2			2			V
V _{IL} Low-level input voltage	0.8			0.8			V
I _{OH} High-level output current	-1			-1			mA
I _{OL} Low-level output current	20			20			mA
T _A Operating free-air temperature	-55	125		0	70		°C

electrical characteristics over recommended operating free-air temperature range (unless otherwise noted)

PARAMETER	TEST CONDITIONS †	SN54S02			SN74S02			UNIT
		MIN	TYP ‡	MAX	MIN	TYP ‡	MAX	
V _{IK}	V _{CC} = MIN, I _I = -18 mA	-1.2			-1.2			V
V _{OH}	V _{CC} = MIN, V _{IL} = 0.8 V, I _{OH} = -1 mA	2.5	3.4		2.7	3.4	V	
V _{OL}	V _{CC} = MIN, V _{IH} = 2 V, I _{OL} = 20 mA	0.5			0.5			V
I _I	V _{CC} = MAX, V _I = 5.5 V	1			1			mA
I _{IH}	V _{CC} = MAX, V _I = 2.7 V	50			50			μA
I _{IL}	V _{CC} = MAX, V _I = 0.5 V	-2			-2			mA
I _{OS} §	V _{CC} = MAX	-40	-100		-40	-100	mA	
I _{CCH}	V _{CC} = MAX, V _I = 0 V	17 29			17 29			mA
I _{CCL}	V _{CC} = MAX, See Note 2	26 45			26 45			mA

† For conditions shown as MIN or MAX, use the appropriate value specified under recommended operating conditions.

‡ All typical values are at V_{CC} = 5 V, T_A = 25°C.

§ Not more than one output should be shorted at a time, and the duration of the short-circuit should not exceed one second.

NOTE 2: One input at 4.5 V, all others at GND.

switching characteristics, V_{CC} = 5 V, T_A = 25°C (see note 3)

PARAMETER	FROM (INPUT)	TO (OUTPUT)	TEST CONDITIONS	MIN	TYP	MAX	UNIT
t _{PLH}	A or B	Y	R _L = 280 Ω, C _L = 15 pF	3.5	5.5	ns	
t _{PHL}				3.5	5.5	ns	
t _{PLH}			R _L = 280 Ω, C _L = 50 pF	5	ns		
t _{PHL}				5	ns		

NOTE 3: See General Information Section for load circuits and voltage waveforms.

3

TTL DEVICES

TYPES SN5403, SN54L03, SN54LS03, SN54S03, SN7403, SN74LS03, SN74S03

QUADRUPLE 2-INPUT POSITIVE-NAND GATES WITH OPEN-COLLECTOR OUTPUTS

REVISED DECEMBER 1983

- Package Options Include Both Plastic and Ceramic Chip Carriers in Addition to Plastic and Ceramic DIPs
- Dependable Texas Instruments Quality and Reliability

description

These devices contain four independent 2-input NAND gates. The open-collector outputs require pull-up resistors to perform correctly. They may be connected to other open-collector outputs to implement active-low wired-OR or active-high wired-AND functions. Open-collector devices are often used to generate higher V_{OH} levels.

The SN5403, SN54L03, SN54LS03 and SN54S03 are characterized for operation over the full military temperature range of -55°C to 125°C . The SN7403, SN74LS03 and SN74S03 are characterized for operation from 0°C to 70°C .

FUNCTION TABLE (each gate)

INPUTS		OUTPUT
A	B	Y
H	H	L
L	X	H
X	L	H

logic diagram (each gate)



positive logic

$$Y = \overline{A \cdot B} \text{ or } Y = \overline{A} + \overline{B}$$

SN5403, SN54L03 . . . J PACKAGE
 SN54LS03, SN54S03 . . . J OR W PACKAGE
 SN7403 . . . J OR N PACKAGE
 SN74LS03, SN74S03 . . . D, J OR N PACKAGE
 (TOP VIEW)

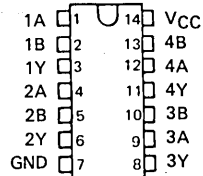

SN54LS03, SN54S03 . . . FK PACKAGE
 SN74LS03, SN74S03 . . . FN PACKAGE
 (TOP VIEW)

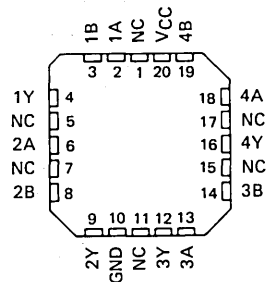

NC - No internal connection



TTL DEVICES

PRODUCTION DATA
 This document contains information current as of publication date. Products conform to specifications per the terms of Texas Instruments standard warranty. Production processing does not necessarily include testing of all parameters.



POST OFFICE BOX 225012 • DALLAS, TEXAS 75265

TYPES SN5403, SN7403 QUADRUPLE 2-INPUT POSITIVE-NAND GATES WITH OPEN-COLLECTOR OUTPUTS

recommended operating conditions

	SN5403			SN7403			UNIT		
	MIN	NOM	MAX	MIN	NOM	MAX			
V _{CC} Supply voltage	4.5	5	5.5	4.75	5	5.25	V		
V _{IH} High-level input voltage	2			2			V		
V _{IL} Low-level input voltage	0.8			0.8			V		
V _{OH} High-level output voltage	5.5			5.5			V		
I _{OL} Low-level output current	16			16			mA		
T _A Operating free-air temperature	-55			125			0	70	°C

electrical characteristics over recommended operating free-air temperature range (unless otherwise noted)

PARAMETER	TEST CONDITIONS†	MIN	TYP‡	MAX	UNIT
V _{IK}	V _{CC} = MIN, I _I = -12 mA		-1.5		V
I _{OH}	V _{CC} = MIN, V _{IL} = 0.8 V, V _{OH} = 5.5 V		0.25		mA
V _{OL}	V _{CC} = MIN, V _{IH} = 2 V, I _{OL} = 16 mA	0.2	0.4		V
I _I	V _{CC} = MAX, V _I = 5.5 V		1		mA
I _{IH}	V _{CC} = MAX, V _I = 2.4 V		40		μA
I _{IL}	V _{CC} = MAX, V _I = 0.4 V		-1.6		mA
I _{CCH}	V _{CC} = MAX, V _I = 0 V		4	8	mA
I _{CCL}	V _{CC} = MAX, V _I = 4.5 V		12	22	mA

† For conditions shown as MIN or MAX, use the appropriate value specified under recommended operating conditions.

‡ All typical values are at V_{CC} = 5 V, T_A = 25°C.

switching characteristics, V_{CC} = 5 V, T_A = 25°C (see note 2)

PARAMETER	FROM (INPUT)	TO (OUTPUT)	TEST CONDITIONS	MIN	TYP	MAX	UNIT
t _{PLH}	A or B	Y	R _L = 4 kΩ, C _L = 15 pF	35	45		ns
t _{PHL}			R _L = 400 Ω, C _L = 15 pF	8	15		ns

NOTE 2: See General Information Section for load circuits and voltage waveforms.

3

TTL DEVICES

TYPES SN54L03

QUADRUPLE 2-INPUT POSITIVE-NAND GATES WITH OPEN-COLLECTOR OUTPUTS

recommended operating conditions

	SN54L03			UNIT
	MIN	NOM	MAX	
V _{CC} Supply voltage	4.5	5	5.5	V
V _{IH} High-level input voltage	2			V
V _{IL} Low-level input voltage	0.6			V
V _{OH} High-level output voltage	5.5			V
I _{OL} Low-level output current	2			mA
T _A Operating free-air temperature	-55	125		°C

electrical characteristics over recommended operating free-air temperature range (unless otherwise noted)

PARAMETER	TEST CONDITIONS†	SN54L03			UNIT
		MIN	TYP‡	MAX	
I _{OH}	V _{CC} = MIN, V _{IL} = 0.6 V, V _{OH} = 5.5 V	50			μA
V _{OL}	V _{CC} = MIN, V _{IH} = 2 V, I _{OL} = 2 mA	0.15	0.3		V
I _I	V _{CC} = MAX, V _I = 5.5 V	0.1			mA
I _{IH}	V _{CC} = MAX, V _I = 2.4 V	10			μA
I _{IL}	V _{CC} = MAX, V _I = 0.3 V	-0.18			mA
I _{CCH}	V _{CC} = MAX, V _I = 0 V	0.44	0.8		mA
I _{CCL}	V _{CC} = MAX, V _I = 4.5 V	1.16	2.04		mA

† For conditions shown as MIN or MAX, use the appropriate value specified under recommended operating conditions.

‡ All typical values are at V_{CC} = 5 V, T_A = 25°C.

switching characteristics, V_{CC} = 5 V, T_A = 25°C (see note 2)

PARAMETER	FROM (INPUT)	TO (OUTPUT)	TEST CONDITIONS	MIN	TYP	MAX	UNIT
t _{PLH}	A or B	Y	R _L = 4 kΩ, C _L = 50 pF	60	90		ns
t _{PHL}				33	60		ns

NOTE 2: See General Information Section for load circuits and voltage waveforms.

3

TTL DEVICES

TYPES SN54LS03, SN74LS03
QUADRUPLE 2-INPUT POSITIVE-NAND GATES WITH OPEN-COLLECTOR OUTPUTS

recommended operating conditions

	SN54LS03			SN74LS03			UNIT
	MIN	NOM	MAX	MIN	NOM	MAX	
V _{CC} Supply voltage	4.5	5	5.5	4.75	5	5.25	V
V _{IH} High-level input voltage	2			2			V
V _{IL} Low-level input voltage			0.7			0.8	V
V _{OH} High-level output voltage			5.5			5.5	V
I _{OL} Low-level output current			4			8	mA
T _A Operating free-air temperature	-55		125	0		70	°C

electrical characteristics over recommended operating free-air temperature range (unless otherwise noted)

PARAMETER	TEST CONDITIONS †	SN54LS03		SN74LS03		UNIT
		MIN	TYP ‡	MAX	MIN	
V _{IK}	V _{CC} = MIN, I _I = -18 mA		-1.5		-1.5	V
I _{OH}	V _{CC} = MIN, V _{IL} = MAX, V _{OH} = 5.5 V			0.1		0.1 mA
V _{OL}	V _{CC} = MIN, V _{IH} = 2 V, I _{OL} = 4 mA	0.25	0.4	0.25	0.4	V
	V _{CC} = MIN, V _{IH} = 2 V, I _{OL} = 8 mA			0.35	0.5	
I _I	V _{CC} = MAX, V _I = 7 V		0.1		0.1	mA
I _{IH}	V _{CC} = MAX, V _I = 2.7 V		20		20	μA
I _{IL}	V _{CC} = MAX, V _I = 0.4 V		-0.4		-0.4	mA
I _{CCH}	V _{CC} = MAX, V _I = 0 V	0.8	1.6	0.8	1.6	mA
I _{CCL}	V _{CC} = MAX, V _I = 4.5 V	2.4	4.4	2.4	4.4	mA

† For conditions shown as MIN or MAX, use the appropriate value specified under recommended operating conditions.

‡ All typical values are at V_{CC} = 5 V, T_A = 25°C.

switching characteristics, V_{CC} = 5 V, T_A = 25°C (see note 2)

PARAMETER	FROM (INPUT)	TO (OUTPUT)	TEST CONDITIONS		MIN	TYP	MAX	UNIT
t _{PLH}	A or B	Y	R _L = 2 kΩ,	C _L = 15 pF		17	32	ns
t _{PHL}						15	28	ns

NOTE 2: See General Information Section for load circuits and voltage waveforms.

3

TTL DEVICES

TYPES SN54S03, SN74S03

QUADRUPLE 2-INPUT POSITIVE-NAND GATES WITH OPEN-COLLECTOR OUTPUTS

recommended operating conditions

	SN54S03			SN74S03			UNIT
	MIN	NOM	MAX	MIN	NOM	MAX	
V _{CC} Supply voltage	4.5	5	5.5	4.75	5	5.25	V
V _{IH} High-level input voltage	2			2			V
V _{IL} Low-level input voltage				0.8			V
V _{OH} High-level output voltage				5.5			V
I _{OL} Low-level output current				20			mA
T _A Operating free-air temperature	- 55			125			°C

electrical characteristics over recommended operating free-air temperature range (unless otherwise noted)

PARAMETER	TEST CONDITIONS†	MIN	TYP‡	MAX	UNIT
V _{IK}	V _{CC} = MIN, I _I = -18 mA			-1.2	V
I _{OH}	V _{CC} = MIN, V _{IL} = 0.8 V, V _{OH} = 5.5 V			0.25	mA
V _{OL}	V _{CC} = MIN, V _{IH} = 2 V, I _{OL} = 20 mA			0.5	V
I _I	V _{CC} = MAX, V _I = 5.5 V			1	mA
I _{IH}	V _{CC} = MAX, V _I = 2.7 V			50	μA
I _{IL}	V _{CC} = MAX, V _I = 0.5 V			-2	mA
I _{CCH}	V _{CC} = MAX, V _I = 0 V		6	13.2	mA
I _{CCL}	V _{CC} = MAX, V _I = 4.5 V		20	36	mA

† For conditions shown as MIN or MAX, use the appropriate value specified under recommended operating conditions.

‡ All typical values are at V_{CC} = 5 V, T_A = 25°C.

switching characteristics, V_{CC} = 5 V, T_A = 25°C (see note 2)

PARAMETER	FROM (INPUT)	TO (OUTPUT)	TEST CONDITIONS		MIN	TYP	MAX	UNIT
t _{PLH}	A or B	Y	R _L = 280 Ω,	C _L = 15 pF	2	5	7.5	ns
t _{PHL}					2	4.5	7	ns
t _{PLH}			R _L = 280 Ω,	C _L = 50 pF	7.5		ns	
t _{PHL}					7		ns	

NOTE 2: See General Information Section for load circuits and voltage waveforms.

TYPES SN5404, SN54H04, SN54L04, SN54LS04, SN54S04, SN7404, SN74H04, SN74LS04, SN74S04 HEX INVERTERS

REVISED DECEMBER 1983

- Package Options Include Both Plastic and Ceramic Chip Carriers in Addition to Plastic and Ceramic DIPs
- Dependable Texas Instruments Quality and Reliability

description

These devices contain six independent inverters.

The SN5404, SN54H04, SN54L04, SN54LS04 and SN54S04 are characterized for operation over the full military temperature range of -55°C to 125°C . The SN7404, SN74H04, SN74LS04 and SN74S04 are characterized for operation from 0°C to 70°C .

FUNCTION TABLE (each inverter)

INPUTS		OUTPUT	
A		Y	
H		L	
L		H	

logic diagram (each inverter)

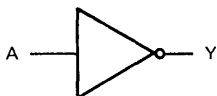

positive logic

$$Y = \bar{A}$$

SN5404, SN54H04, SN54L04 . . . J PACKAGE
SN54LS04, SN54S04 . . . J OR W PACKAGE
SN7404, SN74H04 . . . J OR N PACKAGE
SN74LS04, SN74S04 . . . D, J OR N PACKAGE

(TOP VIEW)

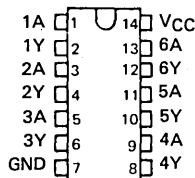

SN5404, SN54H04 . . . W PACKAGE

(TOP VIEW)

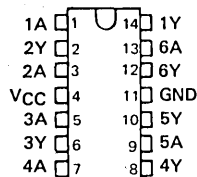

SN54LS04, SN54S04 . . . FK PACKAGE
SN74LS04, SN74S04 . . . FN PACKAGE

(TOP VIEW)

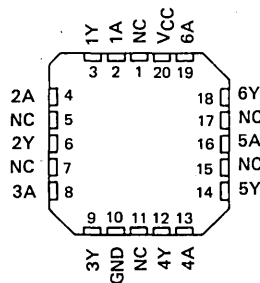

NC - No internal connection

3

TTL DEVICES

PRODUCTION DATA

This document contains information current as of publication date. Products conform to specifications per the terms of Texas Instruments standard warranty. Production processing does not necessarily include testing of all parameters.

TEXAS
INSTRUMENTS

POST OFFICE BOX 225012 • DALLAS, TEXAS 75265

TYPES SN5404, SN54H04, SN54L04, SN54LS04, SN54S04, SN7404, SN74H04, SN74LS04, SN74S04 HEX INVERTERS

schematics (each gate)

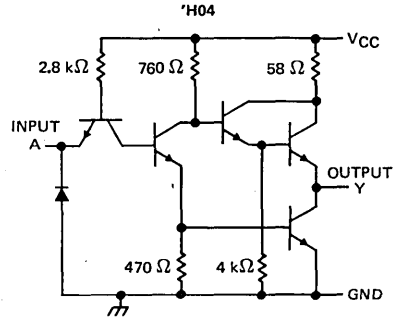
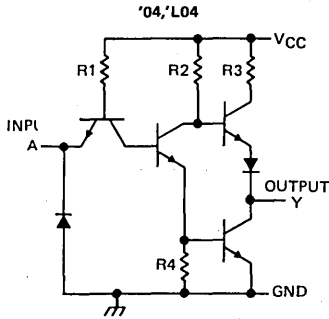

CIRCUIT	R1	R2	R3	R4
'04	4 kΩ	1.6 kΩ	130 Ω	1 kΩ
'L04	40 kΩ	20 kΩ	500 Ω	12 kΩ

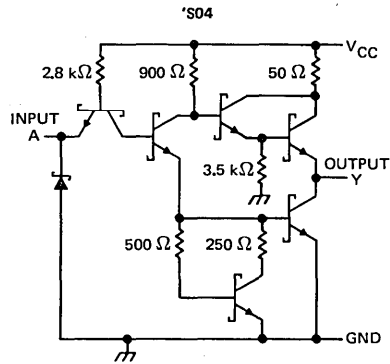
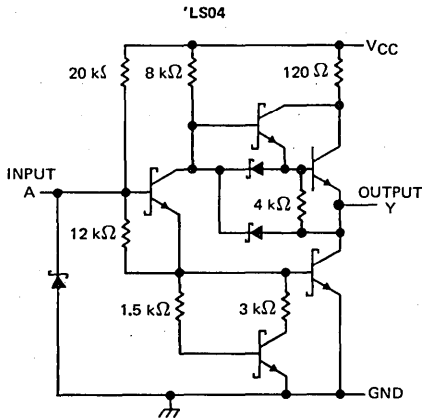

Resistor values shown are nominal.

absolute maximum ratings over operating free-air temperature range (unless otherwise noted)

Supply voltage, V_{CC} (see Note 1): '04, 'H04, 'LS04, 'S04	7 V
'L04	8 V
Input voltage: '04, 'H04, 'L04, 'S04	5.5 V
'LS04	7 V
Operating free-air temperature range: SN54'	-55°C to 125°C
SN74'	0°C to 70°C
Storage temperature range	-65°C to 150°C

NOTE 1: Voltage values are with respect to network ground terminal.

TYPES SN5404, SN7404
HEX INVERTERS

recommended operating conditions

	SN5404			SN7404			UNIT
	MIN	NOM	MAX	MIN	NOM	MAX	
V_{CC} Supply voltage	4.5	5	5.5	4.75	5	5.25	V
V_{IH} High-level input voltage	2			2			V
V_{IL} Low-level input voltage	0.8			0.8			V
I_{OH} High-level output current	-0.4			-0.4			mA
I_{OL} Low-level output current	16			16			mA
T_A Operating free-air temperature	-55	125		0	70		°C

electrical characteristics over recommended operating free-air temperature range (unless otherwise noted)

PARAMETER	TEST CONDITIONS †	SN5404			SN7404			UNIT
		MIN	TYP ‡	MAX	MIN	TYP ‡	MAX	
V_{IK}	$V_{CC} = \text{MIN}, I_I = -12 \text{ mA}$	-1.5			-1.5			V
V_{OH}	$V_{CC} = \text{MIN}, V_{IL} = 0.8 \text{ V}, I_{OH} = -0.4 \text{ mA}$	2.4	3.4		2.4	3.4		V
V_{OL}	$V_{CC} = \text{MIN}, V_{IH} = 2 \text{ V}, I_{OL} = 16 \text{ mA}$	0.2	0.4		0.2	0.4		V
I_I	$V_{CC} = \text{MAX}, V_I = 5.5 \text{ V}$	1			1			mA
I_{IH}	$V_{CC} = \text{MAX}, V_I = 2.4 \text{ V}$	40			40			µA
I_{IL}	$V_{CC} = \text{MAX}, V_I = 0.4 \text{ V}$	-1.6			-1.6			mA
$I_{OS} §$	$V_{CC} = \text{MAX}$	-20	-55		-18	-55		mA
I_{CCH}	$V_{CC} = \text{MAX}, V_I = 0 \text{ V}$	6	12		6	12		mA
I_{CCL}	$V_{CC} = \text{MAX}, V_I = 4.5 \text{ V}$	18	33		18	33		mA

† For conditions shown as MIN or MAX, use the appropriate value specified under recommended operating conditions.

‡ All typical values are at $V_{CC} = 5 \text{ V}, T_A = 25^\circ\text{C}$.

§ Not more than one output should be shorted at a time.

switching characteristics, $V_{CC} = 5 \text{ V}, T_A = 25^\circ\text{C}$ (see note 2)

PARAMETER	FROM (INPUT)	TO (OUTPUT)	TEST CONDITIONS		MIN	TYP	MAX	UNIT
t_{PLH}	A	Y	$R_L = 400 \Omega,$	$C_L = 15 \text{ pF}$		12	22	ns
t_{PHL}						8	15	ns

NOTE 2: See General Information Section for load circuits and voltage waveforms.

3

TTL DEVICES

TYPES SN54H04, SN74H04 HEX INVERTERS

recommended operating conditions

	SN54H04			SN74H04			UNIT
	MIN	NOM	MAX	MIN	NOM	MAX	
V _{CC} Supply voltage	4.5	5	5.5	4.75	5	5.25	V
V _{IH} High-level input voltage	2			2			V
V _{IL} Low-level input voltage				0.8			V
I _{OH} High-level output current				-0.5			mA
I _{OL} Low-level output current				20			mA
T _A Operating free-air temperature	-55			125			°C

electrical characteristics over recommended operating free-air temperature range (unless otherwise noted)

PARAMETER	TEST CONDITIONS†	MIN	TYP‡	MAX	UNIT
V _{IK}	V _{CC} = MIN, I _I = -8 mA			-1.5	V
V _{OH}	V _{CC} = MIN, V _{IL} = 0.8 V, I _{OH} = -0.5 mA	2.4	3.5		V
V _{OL}	V _{CC} = MIN, V _{IH} = 2 V, I _{OL} = 20 mA		0.2	0.4	V
I _I	V _{CC} = MAX, V _I = 5.5 V			1	mA
I _{IH}	V _{CC} = MAX, V _I = 2.4 V			50	μA
I _{IL}	V _{CC} = MAX, V _I = 0.4 V			-2	mA
I _{OS} §	V _{CC} = MAX	-40		-100	mA
I _{CCH}	V _{CC} = MAX, V _I = 0 V		16	26	mA
I _{CCL}	V _{CC} = MAX, V _I = 4.5 V		40	58	mA

† For conditions shown as MIN or MAX, use the appropriate value specified under recommended operating conditions.

‡ All typical values are at V_{CC} = 5 V, T_A = 25°C.

§ Not more than one output should be shorted at a time, and the duration of the short-circuit should not exceed one second.

switching characteristics, V_{CC} = 5 V, T_A = 25°C (see note 2)

PARAMETER	FROM (INPUT)	TO (OUTPUT)	TEST CONDITIONS	MIN	TYP	MAX	UNIT
t _{PLH}	A	Y	R _L = 280 Ω, C _L = 25 pF		6	10	ns
t _{PHL}					6.5	10	ns

NOTE 2: See General Information Section for load circuits and voltage waveforms.

3

TTL DEVICES

recommended operating conditions

	SN54L04			UNIT
	MIN	NOM	MAX	
V _{CC} Supply voltage	4.5	5	5.5	V
V _{IH} High-level input voltage	2			V
V _{IL} Low-level input voltage	0.7			V
I _{OH} High-level output current	-0.1			mA
I _{OL} Low-level output current	2			mA
T _A Operating free-air temperature	-55	125		°C

electrical characteristics over recommended operating free-air temperature range (unless otherwise noted)

PARAMETER	TEST CONDITIONS†	SN54L04			UNIT
		MIN	TYP‡	MAX	
V _{OH}	V _{CC} = MIN, V _{IL} = 0.7 V, I _{OH} = -0.1 mA	2.4	3.3		V
V _{OL}	V _{CC} = MIN, V _{IH} = 2 V, I _{OL} = 2 mA	0.15	0.3		V
I _I	V _{CC} = MAX, V _I = 5.5 V			0.1	mA
I _{IH}	V _{CC} = MAX, V _I = 2.4 V			10	μA
I _{IL}	V _{CC} = MAX, V _I = 0.3 V			-0.18	mA
I _{OS} §	V _{CC} = MAX	-3		-15	mA
I _{CCH}	V _{CC} = MAX, V _I = 0 V	0.66	1.2		mA
I _{CCL}	V _{CC} = MAX, V _I = 4.5 V	1.74	3.06		mA

† For conditions shown as MIN or MAX, use the appropriate value specified under recommended operating conditions.

‡ All typical values are at V_{CC} = 5 V, T_A = 25°C.

§ Not more than one output should be shorted at a time.

switching characteristics, V_{CC} = 5 V, T_A = 25°C (see note 2)

PARAMETER	FROM (INPUT)	TO (OUTPUT)	TEST CONDITIONS	MIN	TYP	MAX	UNIT
t _{PLH}	A	Y	R _L = 4 kΩ, C _L = 50 pF		35	60	ns
t _{PHL}					31	60	ns

NOTE 2: See General Information Section for load circuits and voltage waveforms.

3

TTL DEVICES

TYPES SN54LS04, SN74LS04 HEX INVERTERS

recommended operating conditions

	SN54LS04			SN74LS04			UNIT
	MIN	NOM	MAX	MIN	NOM	MAX	
V _{CC} Supply voltage	4.5	5	5.5	4.75	5	5.25	V
V _{IH} High-level input voltage	2			2			V
V _{IL} Low-level input voltage	0.7			0.8			V
I _{OH} High-level output current	-0.4			-0.4			mA
I _{OL} Low-level output current	4			8			mA
T _A Operating free-air temperature	-55			125			°C

electrical characteristics over recommended operating free-air temperature range (unless otherwise noted)

PARAMETER	TEST CONDITIONS †	SN54LS04		SN74LS04		UNIT
		MIN	TYP ‡	MAX	MIN	
V _{IK}	V _{CC} = MIN, I _I = -18 mA	-1.5		-1.5		V
V _{OH}	V _{CC} = MIN, V _{IL} = MAX, I _{OH} = -0.4 mA	2.5	3.4	2.7	3.4	V
V _{OL}	V _{CC} = MIN, V _{IH} = 2 V, I _{OL} = 4 mA	0.25		0.4		V
	V _{CC} = MIN, V _{IH} = 2 V, I _{OL} = 8 mA			0.25	0.5	
I _I	V _{CC} = MAX, V _I = 7 V	0.1		0.1		mA
I _{IH}	V _{CC} = MAX, V _I = 2.7 V	20		20		µA
I _{IL}	V _{CC} = MAX, V _I = 0.4 V	-0.4		-0.4		mA
I _{OS} §	V _{CC} = MAX	-20	-100	-20	-100	mA
I _{CCH}	V _{CC} = MAX, V _I = 0 V	1.2		1.2		mA
I _{CCL}	V _{CC} = MAX, V _I = 4.5 V	3.6		3.6		mA

† For conditions shown as MIN or MAX, use the appropriate value specified under recommended operating conditions.

‡ All typical values are at V_{CC} = 5 V, T_A = 25°C.

§ Not more than one output should be shorted at a time, and the duration of the short-circuit should not exceed one second.

switching characteristics, V_{CC} = 5 V, T_A = 25°C (see note 2)

PARAMETER	FROM (INPUT)	TO (OUTPUT)	TEST CONDITIONS		MIN	TYP	MAX	UNIT
t _{PLH}	A	Y	R _L = 2 kΩ,	C _L = 15 pF		9	15	ns
t _{PHL}						10	15	ns

NOTE 2: See General Information Section for load circuits and voltage waveforms.

TYPES SN54S04, SN74S04 HEX INVERTERS

recommended operating conditions

	SN54S04			SN74S04			UNIT
	MIN	NOM	MAX	MIN	NOM	MAX	
V _{CC} Supply voltage	4.5	5	5.5	4.75	5	5.25	V
V _{IH} High-level input voltage	2			2			V
V _{IL} Low-level input voltage				0.8			V
I _{OH} High-level output current				-1			mA
I _{OL} Low-level output current				20			mA
T _A Operating free-air temperature	-55			125			°C

electrical characteristics over recommended operating free-air temperature range (unless otherwise noted)

PARAMETER	TEST CONDITIONS †	SN54S04			SN74S04			UNIT
		MIN	TYP ‡	MAX	MIN	TYP ‡	MAX	
V _{IK}	V _{CC} = MIN, I _I = -18 mA	-1.2			-1.2			V
V _{OH}	V _{CC} = MIN, V _{IL} = 0.8 V, I _{OH} = -1 mA	2.5	3.4		2.7	3.4	V	
V _{OL}	V _{CC} = MIN, V _{IH} = 2 V, I _{OL} = 20 mA	0.5			0.5			V
I _I	V _{CC} = MAX, V _I = 5.5 V	1			1			mA
I _{IH}	V _{CC} = MAX, V _I = 2.7 V	50			50			μA
I _{IL}	V _{CC} = MAX, V _I = 0.5 V	-2			-2			mA
I _{OS} §	V _{CC} = MAX	-40		-100	-40		-100	mA
I _{CCH}	V _{CC} = MAX, V _I = 0 V	15			15			mA
I _{CCL}	V _{CC} = MAX, V _I = 4.5 V	30			30			mA

† For conditions shown as MIN or MAX, use the appropriate value specified under recommended operating conditions.

‡ All typical values are at V_{CC} = 5 V, T_A = 25°C.

§ Not more than one output should be shorted at a time, and the duration of the short-circuit should not exceed one second.

switching characteristics, V_{CC} = 5 V, T_A = 25°C (see note 2)

PARAMETER	FROM (INPUT)	TO (OUTPUT)	TEST CONDITIONS		MIN	TYP	MAX	UNIT
t _{PLH}	A	Y	R _L = 280 Ω,	C _L = 15 pF		3	4.5	ns
t _{PHL}						3	5	ns
t _{PLH}			R _L = 280 Ω,	C _L = 50 pF		4.5		ns
t _{PHL}						5		ns

NOTE 2: See General Information Section for load circuits and voltage waveforms.

3

TTL DEVICES



TTL DEVICES

TYPES SN5405, SN54H05, SN54LS05, SN54S05, SN7405, SN74H05, SN74LS05, SN74S05 HEX INVERTERS WITH OPEN-COLLECTOR OUTPUTS

REVISED DECEMBER 1983

- Package Options Include Both Plastic and Ceramic Chip Carriers in Addition to Plastic and Ceramic DIPs
- Dependable Texas Instruments Quality and Reliability

description

These devices contain six independent inverters. The open-collector outputs require pull-up resistors to perform correctly. They may be connected to other open-collector outputs to implement active-low wired-OR or active-high wired-AND functions. Open collector devices are often used to generate high V_{OH} levels.

The SN5405, SN54H05, SN54LS05 and SN54S05 are characterized for operation over the full military temperature range of -55°C to 125°C . The SN7405, SN74H05, SN74LS05 and SN74S05 are characterized for operation from 0°C to 70°C .

FUNCTION TABLE (each inverter)

INPUT	OUTPUT
A	Y
H	L
L	H

logic diagram (each inverter)

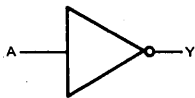

positive logic

$$Y = \overline{A}$$

SN5405, SN54H05 ... J PACKAGE
SN54LS05, SN54S05 ... J OR W PACKAGE
SN7405, SN74H05 ... J OR N PACKAGE
SN74LS05, SN74S05 ... D, J OR N PACKAGE

(TOP VIEW)

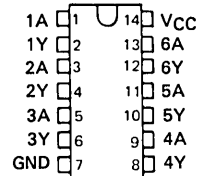

SN5405, SN54H05 ... W PACKAGE
(TOP VIEW)

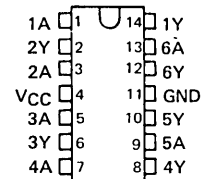

SN54LS05, SN54S05 ... FK PACKAGE
SN74LS05, SN74S05 ... FN PACKAGE
(TOP VIEW)

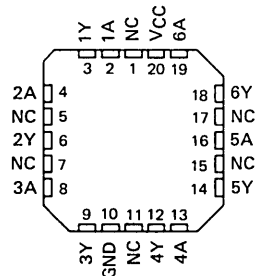

NC - No internal connection

TTL DEVICES

PRODUCTION DATA

This document contains information current as of publication date. Products conform to specifications per the terms of Texas Instruments standard warranty. Production processing does not necessarily include testing of all parameters.

**TYPES SN5405, SN54H05, SN54LS05, SN54S05,
SN7405, SN74H05, SH74LS05, SN74S05
HEX INVERTERS WITH OPEN-COLLECTOR OUTPUTS**

schematics (each inverter)

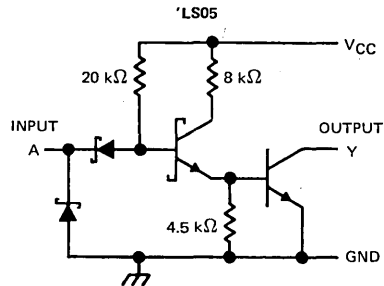
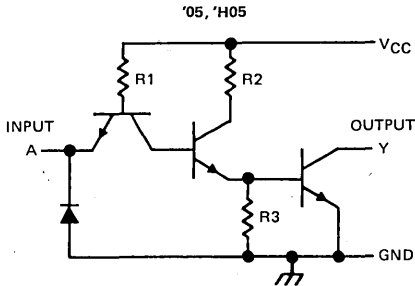

CIRCUITS	R1	R2	R3
'05	4KΩ	1.6KΩ	1KΩ
'H05	2.8KΩ	760Ω	470Ω

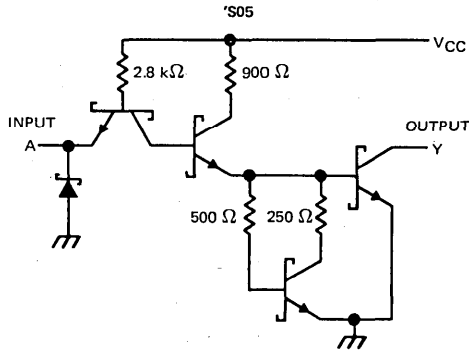

Resistor values are nominal.

absolute maximum ratings over operating free-air temperature range (unless otherwise noted)

Supply voltage, V_{CC} (see Note 1): '05, 'H05, 'LS05, 'S05	7 V
Input voltage: '05, 'H05, 'S05	5.5 V
'LS05	7 V
Off-state output voltage	7 V
Operating free-air temperature range: SN54'	-55°C to 125°C
SN74'	0°C to 70°C
Storage temperature range	-65°C to 150°C

NOTE 1: Voltage values are with respect to network ground terminal.

TYPES SN5405, SN7405 HEX INVERTERS WITH OPEN-COLLECTOR OUTPUTS

recommended operating conditions

	SN5405			SN7405			UNIT
	MIN	NOM	MAX	MIN	NOM	MAX	
V _{CC} Supply voltage	4.5	5	5.5	4.75	5	5.25	V
V _{IH} High-level input voltage	2			2			V
V _{IL} Low-level input voltage			0.8			0.8	V
V _{OH} High-level output voltage			5.5			5.5	V
I _{OL} Low-level output current			16			16	mA
T _A Operating free-air temperature	-55		125	0		70	°C

electrical characteristics over recommended operating free-air temperature range (unless otherwise noted)

PARAMETER	TEST CONDITIONS†	MIN	TYP‡	MAX	UNIT
V _{IK}	V _{CC} = MIN, I _I = -12 mA		-1.5		V
I _{OH}	V _{CC} = MIN, V _{IL} = 0.8 V, V _{OH} = 5.5 V		0.25		mA
V _{OL}	V _{CC} = MIN, V _{IH} = 2 V, I _{OL} = 16 mA	0.2	0.4		V
I _I	V _{CC} = MAX, V _I = 5.5 V		1		mA
I _{IH}	V _{CC} = MAX, V _I = 2.4 V		40		μA
I _{IL}	V _{CC} = MAX, V _I = 0.4 V		-1.6		mA
I _{CCCH}	V _{CC} = MAX, V _I = 0 V		6	12	mA
I _{CCL}	V _{CC} = MAX, V _I = 4.5 V		18	33	mA

† For conditions shown as MIN or MAX, use the appropriate value specified under recommended operating conditions.

‡ All typical values are at V_{CC} = 5 V, T_A = 25°C.

switching characteristics, V_{CC} = 5 V, T_A = 25°C (see note 2)

PARAMETER	FROM (INPUT)	TO (OUTPUT)	TEST CONDITIONS	MIN	TYP	MAX	UNIT
t _{PLH}	A	Y	R _L = 4 kΩ, C _L = 15 pF	40	55		ns
t _{PHL}			R _L = 400 Ω, C _L = 15 pF	8	15		ns

NOTE 2: See General Information Section for load circuits and voltage waveforms.

3

TTL DEVICES

TYPES SN54H05, SN74H05 HEX INVERTERS WITH OPEN-COLLECTOR OUTPUTS

recommended operating conditions

	SN54H05			SN74H05			UNIT
	MIN	NOM	MAX	MIN	NOM	MAX	
V_{CC} Supply voltage	4.5	5	5.5	4.75	5	5.25	V
V_{IH} High-level input voltage	2			2			V
V_{IL} Low-level input voltage			0.8			0.8	V
V_{OH} High-level output voltage			5.5			5.5	V
I_{OL} Low-level output current			20			20	mA
T_A Operating free-air temperature	-55		125	0		70	°C

electrical characteristics over recommended operating free-air temperature range (unless otherwise noted)

PARAMETER	TEST CONDITIONS†	MIN	TYP‡	MAX	UNIT
V_{IK}	$V_{CC} = \text{MIN}$, $I_I = -8 \text{ mA}$			-1.5	V
I_{OH}	$V_{CC} = \text{MIN}$, $V_{IL} = 0.8 \text{ V}$, $V_{OH} = 5.5 \text{ V}$			0.25	mA
V_{OL}	$V_{CC} = \text{MIN}$, $V_{IH} = 2 \text{ V}$, $I_{OL} = 20 \text{ mA}$		0.2	0.4	V
I_I	$V_{CC} = \text{MAX}$, $V_I = 5.5 \text{ V}$			1	mA
I_{IH}	$V_{CC} = \text{MAX}$, $V_I = 2.4 \text{ V}$			50	μA
I_{IL}	$V_{CC} = \text{MAX}$, $V_I = 0.4 \text{ V}$			-2	mA
I_{CCH}	$V_{CC} = \text{MAX}$, $V_I = 0 \text{ V}$		16	26	mA
I_{CCL}	$V_{CC} = \text{MAX}$, $V_I = 4.5 \text{ V}$		40	58	mA

† For conditions shown as MIN or MAX, use the appropriate value specified under recommended operating conditions.

‡ All typical values are at $V_{CC} = 5 \text{ V}$, $T_A = 25^\circ\text{C}$.

switching characteristics, $V_{CC} = 5 \text{ V}$, $T_A = 25^\circ\text{C}$ (see note 2)

PARAMETER	FROM (INPUT)	TO (OUTPUT)	TEST CONDITIONS	MIN	TYP	MAX	UNIT
t_{PLH}	A	Y	$R_L = 280 \Omega$, $C_L = 25 \text{ pF}$		10	15	ns
t_{PHL}					7.5	12	ns

NOTE 2: See General Information Section for load circuits and voltage waveforms.

3

TTL DEVICES

TYPES SN54LS05, SN74LS05 HEX INVERTERS WITH OPEN-COLLECTOR OUTPUTS

recommended operating conditions

	SN54LS05			SN74LS05			UNIT
	MIN	NOM	MAX	MIN	NOM	MAX	
V _{CC} Supply voltage	4.5	5	5.5	4.75	5	5.25	V
V _{IH} High-level input voltage	2			2			V
V _{IL} Low-level input voltage	0.7			0.8			V
V _{OH} High-level output voltage	5.5			5.5			V
I _{OL} Low-level output current	4			8			mA
T _A Operating free-air temperature	- 55			125			°C

electrical characteristics over recommended operating free-air temperature range (unless otherwise noted)

PARAMETER	TEST CONDITIONS†	SN54LS05		SN74LS05		UNIT
		MIN	TYP‡	MAX	MIN	
V _{IK}	V _{CC} = MIN, I _I = - 18 mA	- 1.5		- 1.5		V
I _{OH}	V _{CC} = MIN, V _{IL} = MAX, V _{OH} = 5.5 V	0.1		0.1		mA
V _{OL}	V _{CC} = MIN, V _{IH} = 2 V, I _{OL} = 4 mA	0.25	0.4	0.25	0.4	V
	V _{CC} = MIN, V _{IH} = 2 V, I _{OL} = 8 mA			0.35	0.5	
I _I	V _{CC} = MAX, V _I = 7 V	0.1		0.1		mA
I _{IH}	V _{CC} = MAX, V _I = 2.7 V	20		20		μA
I _{IL}	V _{CC} = MAX, V _I = 0.4 V	- 0.4		- 0.4		mA
I _{CCH}	V _{CC} = MAX, V _I = 0 V	1.2	2.4	1.2	2.4	mA
I _{CCL}	V _{CC} = MAX, V _I = 4.5 V	3.6	6.6	3.6	6.6	mA

† For conditions shown as MIN or MAX, use the appropriate value specified under recommended operating conditions.

‡ All typical values are at V_{CC} = 5 V, T_A = 25°C.

switching characteristics, V_{CC} = 5 V, T_A = 25°C (see note 2)

PARAMETER	FROM (INPUT)	TO (OUTPUT)	TEST CONDITIONS		MIN	TYP	MAX	UNIT
t _{PLH}	A	Y	R _L = 2 kΩ,	C _L = 15 pF	17	32	ns	
t _{PHL}					15	28	ns	

NOTE 2: See General Information Section for load circuits and voltage waveforms.

3

TTL DEVICES

TYPES SN54S05, SN74S05 HEX INVERTERS WITH OPEN-COLLECTOR OUTPUTS

recommended operating conditions

	SN54S05			SN74S05			UNIT
	MIN	NOM	MAX	MIN	NOM	MAX	
V _{CC} Supply voltage	4.5	5	5.5	4.75	5	5.25	V
V _{IH} High-level input voltage	2			2			V
V _{IL} Low-level input voltage	0.8			0.8			V
V _{OH} High-level output voltage	5.5			5.5			V
I _{OL} Low-level output current	20			20			mA
T _A Operating free-air temperature	-55			125			0 70 °C

electrical characteristics over recommended operating free-air temperature range (unless otherwise noted)

PARAMETER	TEST CONDITIONS †	SN54S05			SN74S05			UNIT
		MIN	TYP ‡	MAX	MIN	TYP ‡	MAX	
V _{IK}	V _{CC} = MIN, I _I = -18 mA	-1.2			-1.2			V
I _{OH}	V _{CC} = MIN, V _{IL} = 0.8 V, V _{OH} = 5.5 V	0.25			0.25			mA
V _{OL}	V _{CC} = MIN, V _{IH} = 2 V, I _{OL} = 20 mA	0.5			0.5			V
I _I	V _{CC} = MAX, V _I = 5.5 V	1			1			mA
I _{IH}	V _{CC} = MAX, V _I = 2.7 V	50			50			μA
I _{IL}	V _{CC} = MAX, V _I = 0.5 V	-2			-2			mA
I _{CCH}	V _{CC} = MAX, V _I = 0 V	9 19.8			9 19.8			mA
I _{CCL}	V _{CC} = MAX, V _I = 4.5 V	30 54			30 54			mA

† For conditions shown as MIN or MAX, use the appropriate value specified under recommended operating conditions.

‡ All typical values are at V_{CC} = 5 V, T_A = 25°C.

switching characteristics, V_{CC} = 5 V, T_A = 25°C (see note 2)

PARAMETER	FROM (INPUT)	TO (OUTPUT)	TEST CONDITIONS	MIN	TYP	MAX	UNIT
t _{PLH}	A	Y	R _L = 280 Ω, C _L = 15 pF	2	5	7.5	ns
t _{PHL}				2	4.5	7	ns
t _{PLH}			R _L = 280 Ω, C _L = 50 pF	7.5	ns		
t _{PHL}				7	ns		

NOTE 2: See General Information Section for load circuits and voltage waveforms.

TYPES SN5406, SN5416, SN7406, SN7416 HEX INVERTER BUFFERS/DRIVERS WITH OPEN-COLLECTOR HIGH-VOLTAGE OUTPUTS

REVISED DECEMBER 1983

- Converts TTL Voltage Levels to MOS Levels
- High Sink-Current Capability
- Input Clamping Diodes Simplify System Design
- Open-Collector Driver for Indicator Lamps and Relays
- Inputs Fully Compatible with Most TTL Circuits

SN5406, SN5416 . . . J OR W PACKAGE

SN7406, SN7416 . . . J OR N PACKAGE

(TOP VIEW)

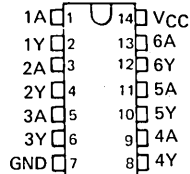

description

These monolithic TTL hex inverter buffers/drivers feature high-voltage open-collector outputs for interfacing with high-level circuits (such as MOS), or for driving high-current loads (such as lamps or relays), and are also characterized for use as inverter buffers for driving TTL inputs. The SN5406 and SN7406 have minimum breakdown voltages of 30 volts and the SN5416 and SN7416 have minimum breakdown voltages of 15 volts. The maximum sink current is 30 milliamperes for the SN5406 and SN5416, and 40 milliamperes for the SN7406 and SN7416.

logic diagram

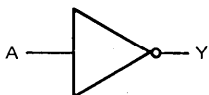

positive logic

$$Y = \bar{A}$$

schematic

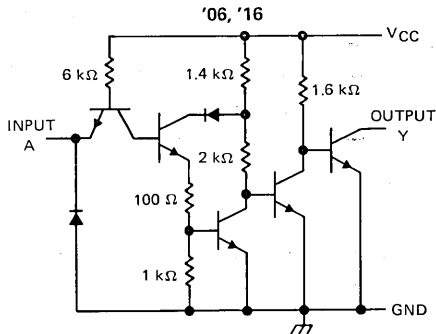

Resistor values shown are nominal.

3

TTL DEVICES

TYPES SN5406, SN5416, SN7406, SN7416 HEX INVERTER BUFFERS/DRIVERS WITH OPEN-COLLECTOR HIGH-VOLTAGE OUTPUTS

absolute maximum ratings over operating free-air temperature range (unless otherwise noted)

Supply voltage, V_{CC} (see Note 1)	7 V
Input voltage (see Note 1)	5.5 V
Output voltage (see Notes 1 and 2): SN5406, SN7406 Circuits	30 V
SN5416, SN7416 Circuits	15 V
Operating free-air temperature range: SN5406, SN5416 Circuits	-55°C to 125°C
SN7406, SN7416 Circuits	0°C to 70°C
Storage temperature range	-65°C to 150°C

- NOTES: 1. Voltage values are with respect to network ground terminal.
2. This is the maximum voltage which should be applied to any output when it is in the off state.

recommended operating conditions

	SN5406 SN5416			SN7406 SN7416			UNIT
	MIN	NOM	MAX	MIN	NOM	MAX	
V_{CC} Supply voltage	4.5	5	5.5	4.75	5	5.25	V
V_{IH} High-level input voltage	2			2			V
V_{IL} Low-level input voltage	0.8			0.8			V
V_{OH} High-level output voltage	'06			30			V
	'16			15			
I_{OL} Low-level output current	30			40			mA
T_A Operating free-air temperature	-55			125			°C

electrical characteristics over recommended operating free-air temperature range (unless otherwise noted)

PARAMETER	TEST CONDITIONS†	SN5406 SN5416			SN7406 SN7416			UNIT
		MIN	TYP‡	MAX	MIN	TYP‡	MAX	
V_{IK}	$V_{CC} = \text{MIN}$, $I_I = -12 \text{ mA}$	-1.5			-1.5			V
I_{OH}	$V_{CC} = \text{MIN}$, $V_{IL} = 0.8 \text{ V}$, $V_{OH} = \S$	0.25			0.25			mA
V_{OL}	$V_{CC} = \text{MIN}$, $V_{IH} = 2 \text{ V}$	$I_{OL} = 16 \text{ mA}$			0.4			V
		$I_{OL} = \P$			0.7			
I_I	$V_{CC} = \text{MAX}$, $V_I = 5.5 \text{ V}$	1			1			mA
I_{IH}	$V_{CC} = \text{MAX}$, $V_{IH} = 2.4 \text{ V}$	40			40			μA
I_{IL}	$V_{CC} = \text{MAX}$, $V_{IL} = 0.4 \text{ V}$	-1.6			-1.6			mA
I_{CCH}	$V_{CC} = \text{MAX}$	30 48			30 48			mA
I_{CCL}	$V_{CC} = \text{MAX}$	32 51			32 51			mA

† For conditions shown as MIN or MAX, use the appropriate value specified under recommended operating conditions.

‡ All typical values are at $V_{CC} = 5 \text{ V}$, $T_A = 25^\circ\text{C}$.

§ $V_{OH} = 30 \text{ V}$ for '06 and 15 V for '16.

¶ $I_{OL} = 30 \text{ mA}$ for SN54' and 40 mA for SN74'.

switching characteristics, $V_{CC} = 5 \text{ V}$, $T_A = 25^\circ\text{C}$ (see note 3)

PARAMETER	FROM (INPUT)	TO (OUTPUT)	TEST CONDITIONS		MIN	TYP	MAX	UNIT
t_{PLH}	A	Y	$R_L = 110 \Omega$	$C_L = 15 \text{ pF}$	10		15	ns
t_{PHL}					15		23	ns

NOTE 3: See General Information Section for load circuits and voltage waveforms.

TYPES SN5407, SN5417, SN7407, SN7417 HEX BUFFERS/DRIVERS WITH OPEN-COLLECTOR HIGH-VOLTAGE OUTPUTS

REVISED DECEMBER 1983

- Converts TTL Voltage Levels to MOS Levels
- High Sink-Current Capability
- Input Clamping Diodes Simplify System Design
- Open-Collector Driver for Indicator Lamps and Relays
- Inputs Fully Compatible with Most TTL Circuits

SN5407, SN5417 ... J OR W PACKAGE
SN7407, SN7417 ... J OR N PACKAGE
(TOP VIEW)

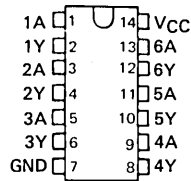

description

These monolithic TTL hex buffers/drivers feature high-voltage open-collector outputs for interfacing with high-level circuits (such as MOS), or for driving high-current loads (such as lamps or relays), and are also characterized for use as buffers for driving TTL inputs. The SN5407 and SN7407 have minimum breakdown voltages of 30 volts and the SN5417 and SN7417 have minimum breakdown voltages of 15 volts. The maximum sink current is 30 milliamperes for the SN5407 and SN5417, and 40 milliamperes for the SN7407 and SN7417.

These circuits are completely compatible with most TTL families. Inputs are diode-clamped to minimize transmission-line effects which simplifies design. Typical power dissipation is 145 milliwatts and average propagation delay time is 14 nanoseconds. The SN5407 and SN5417 are characterized for operation over the full military temperature range of -55°C to 125°C ; the SN7407 and SN7417 are characterized for operation from 0°C to 70°C .

logic diagram (each gate)

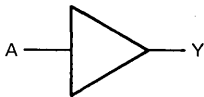

positive logic (each gate)

$$Y = A$$

schematic

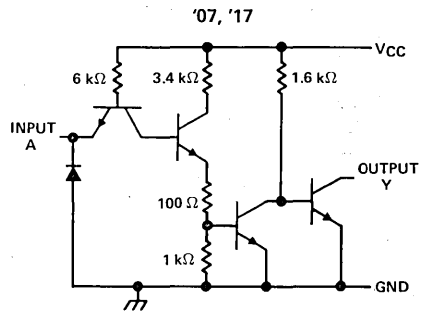

Resistor values shown are nominal.

PRODUCTION DATA
This document contains information current as of publication date. Products conform to specifications per the terms of Texas Instruments standard warranty. Production processing does not necessarily include testing of all parameters.

**TEXAS
INSTRUMENTS**

POST OFFICE BOX 225012 • DALLAS, TEXAS 75265

3

TTL DEVICES

TYPES SN5407, SN5417, SN7407, SN7417 HEX BUFFERS/DRIVERS WITH OPEN-COLLECTOR HIGH-VOLTAGE OUTPUTS

absolute maximum ratings over operating free-air temperature range (unless otherwise noted)

Supply voltage V_{CC} (see Note 1)	7 V
Input voltage (see Note 1)	5.5 V
Output voltage (see Notes 1 and 2): SN5407, SN7407 Circuits	30 V
SN5417, SN7417 Circuits	15 V
Operating free-air temperature range: SN5407, SN5417 Circuits	-55°C to 125°C
SN7407, SN7417 Circuits	0°C to 70°C
Storage temperature range	-65°C to 150°C

- NOTES: 1. Voltage values are with respect to network ground terminal.
2. This is the maximum voltage which should be applied to any output when it is in the off state.

recommended operating conditions

	SN5407 SN5417			SN7407 SN7417			UNIT
	MIN	NOM	MAX	MIN	NOM	MAX	
V_{CC} Supply voltage	4.5	5	5.5	4.75	5	5.25	V
V_{IH} High-level input voltage	2			2			V
V_{IL} Low-level input voltage	0.8			0.8			V
V_{OH} High-level output voltage	'07	30		30			V
	'17	15		15			
I_{OL} Low-level output current	30			40			mA
T_A Operating free-air temperature	-55		125	0		70	°C

electrical characteristics over recommended operating free-air temperature range (unless otherwise noted)

PARAMETER	TEST CONDITIONS†	SN5407 SN5417			SN7407 SN7417			UNIT
		MIN	TYP‡	MAX	MIN	TYP‡	MAX	
V_{IK}	$V_{CC} = \text{MIN}$, $I_I = -12 \text{ mA}$	-1.5			-1.5			V
I_{OH}	$V_{CC} = \text{MIN}$, $V_{IL} = 0.8 \text{ V}$, $V_{OH} = §$	0.25			0.25			mA
V_{OL}	$V_{CC} = \text{MIN}$, $V_{IH} = 2 \text{ V}$	$I_{OL} = 16 \text{ mA}$			0.4			V
		$I_{OL} = ¶$			0.7			
I_I	$V_{CC} = \text{MAX}$, $V_I = 5.5 \text{ V}$	1			1			mA
I_{IH}	$V_{CC} = \text{MAX}$, $V_{IH} = 2.4 \text{ V}$	40			40			mA
I_{IL}	$V_{CC} = \text{MAX}$, $V_{IL} = 0.4 \text{ V}$	-1.6			-1.6			mA
I_{CCH}	$V_{CC} = \text{MAX}$	29		41	29		41	mA
I_{CCL}	$V_{CC} = \text{MAX}$	21		30	21		30	mA

† For conditions shown as MIN or MAX, use the appropriate value specified under recommended operating conditions.

‡ All typical values are at $V_{CC} = 5 \text{ V}$, $T_A = 25^\circ\text{C}$.

§ $V_{OH} = 30 \text{ V}$ for '07 and 15 V for '17.

¶ $I_{OL} = 30 \text{ mA}$ for SN54' and 40 mA for SN74'.

switching characteristics, $V_{CC} = 5 \text{ V}$, $T_A = 25^\circ\text{C}$ (see note 3)

PARAMETER	FROM (INPUT)	TO (OUTPUT)	TEST CONDITIONS	MIN	TYP	MAX	UNIT
t_{PLH}	A	Y	$R_L = 110 \Omega$, $C_L = 15 \text{ pF}$			6	10
t_{PHL}				20	30	ns	

NOTE 3: See General Information Section for load circuits and voltage waveforms.

3

TTL DEVICES

TYPES SN5408, SN54LS08, SN54S08, SN7408, SN74LS08, SN74S08 QUADRUPLE 2-INPUT POSITIVE-AND GATES

REVISED DECEMBER 1983

- Package Options Include Both Plastic and Ceramic Chip Carriers in Addition to Plastic and Ceramic DIPs
- Dependable Texas Instruments Quality and Reliability

description

These devices contain four independent 2-input AND gates.

The SN5408, SN54LS08, and SN54S08 are characterized for operation over the full military temperature range of -55°C to 125°C . The SN7408, SN74LS08 and SN74S08 are characterized for operation from 0°C to 70°C .

FUNCTION TABLE (each gate)

INPUTS		OUTPUT
A	B	Y
H	H	H
L	X	L
X	L	L

logic diagram (each gate)



positive logic

$$Y = A \cdot B \text{ or } Y = \overline{\overline{A} + \overline{B}}$$

SN5408, SN54LS08, SN54S08 ... J OR W PACKAGE
SN7408 ... J OR N PACKAGE
SN74LS08, SN74S08 ... D, J OR N PACKAGE
(TOP VIEW)

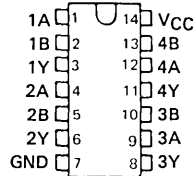

SN54LS08, SN54S08 ... FK PACKAGE
SN74LS08, SN74S08 ... FN PACKAGE
(TOP VIEW)

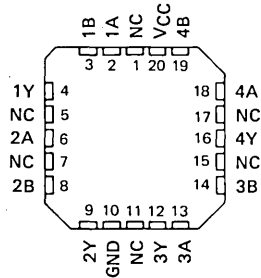

NC - No internal connection



TTL DEVICES

TEXAS
INSTRUMENTS

POST OFFICE BOX 225012 • DALLAS, TEXAS 75265

**TYPES SN5408, SN54LS08, SN54S08,
SN7408, SN74LS08, SN74S08
QUADRUPLE 2-INPUT POSITIVE-AND GATES**

schematics (each gate)

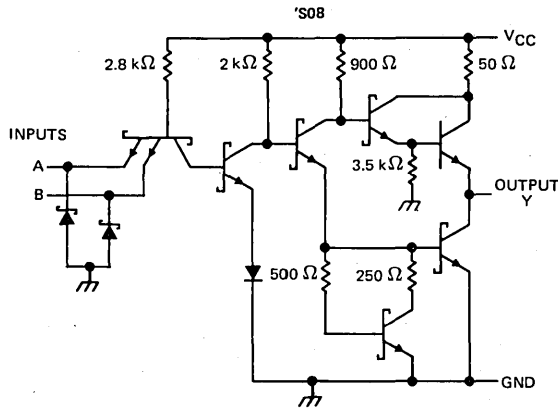
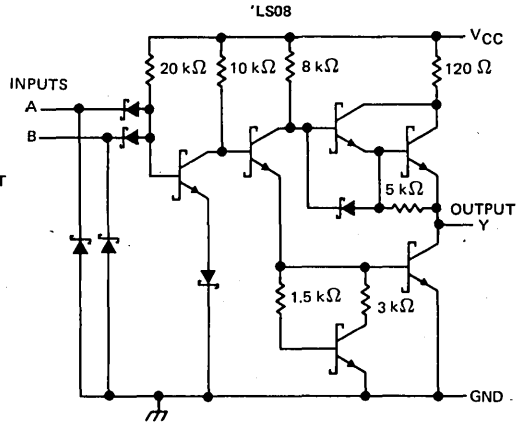
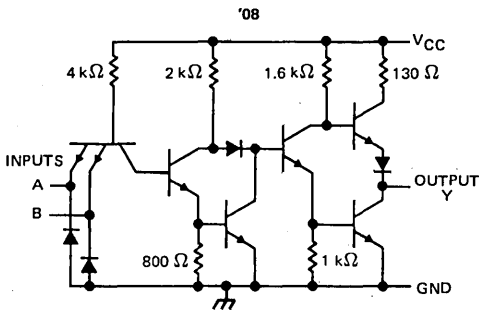

Resistor values are nominal.

absolute maximum ratings over operating free-air temperature range (unless otherwise noted)

Supply voltage, V_{CC} (see Note 1)	7 V
Input voltage: '08, 'S08	5.5 V
'LS08	7 V
Operating free-air temperature range: SN54'	-55°C to 125°C
SN74'	0°C to 70°C
Storage temperature range	-65°C to 150°C

NOTE 1: Voltage values are with respect to network ground terminal.

TYPES SN5408, SN7408
QUADRUPLE 2-INPUT POSITIVE-AND GATES

recommended operating conditions

	SN5408			SN7408			UNIT
	MIN	NOM	MAX	MIN	NOM	MAX	
V _{CC} Supply voltage	4.5	5	5.5	4.75	5	5.25	V
V _{IH} High-level input voltage	2			2			V
V _{IL} Low-level input voltage	0.8			0.8			V
I _{OH} High-level output current	-0.8			-0.8			mA
I _{OL} Low-level output current	16			16			mA
T _A Operating free-air temperature	-55 125			0 70			°C

electrical characteristics over recommended operating free-air temperature range (unless otherwise noted)

PARAMETER	TEST CONDITIONS †	SN5408			SN7408			UNIT
		MIN	TYP‡	MAX	MIN	TYP‡	MAX	
V _{IK}	V _{CC} = MIN, I _I = -12 mA	-1.5			-1.5			V
V _{OH}	V _{CC} = MIN, V _{IH} = 2 V, I _{OH} = -0.8 mA	2.4	3.4		2.4	3.4		V
V _{OL}	V _{CC} = MIN, V _{IL} = 0.8 V, I _{OL} = 16 mA	0.2 0.4			0.2 0.4			V
I _I	V _{CC} = MAX, V _I = 5.5 V	1			1			mA
I _{IH}	V _{CC} = MAX, V _I = 2.4 V	40			40			μA
I _{IL}	V _{CC} = MAX, V _I = 0.4 V	-1.6			-1.6			mA
I _{OS} §	V _{CC} = MAX	-20	-55		-18	-55		mA
I _{CCH}	V _{CC} = MAX, V _I = 4.5 V	11 21			11 21			mA
I _{CCL}	V _{CC} = MAX, V _I = 0 V	20 33			20 33			mA

† For conditions shown as MIN or MAX, use the appropriate value specified under recommended operating conditions.

‡ All typical values are at V_{CC} = 5 V, T_A = 25°C.

§ Not more than one output should be shorted at a time.

switching characteristics, V_{CC} = 5 V, T_A = 25°C (see note 2)

PARAMETER	FROM (INPUT)	TO (OUTPUT)	TEST CONDITIONS		MIN	TYP	MAX	UNIT
t _{PLH}	A or B	Y	R _L = 400 Ω,	C _L = 15 pF	17.5 27		ns	
t _{PHL}					12 19			

NOTE 2: See General Information Section for load circuits and voltage waveforms.

TTL DEVICES

TYPES SN54LS08, SN74LS08 QUADRUPLE 2-INPUT POSITIVE-AND GATES

recommended operating conditions

	SN54LS08			SN74LS08			UNIT
	MIN	NOM	MAX	MIN	NOM	MAX	
V _{CC} Supply voltage	4.5	5	5.5	4.75	5	5.25	V
V _{IH} High-level input voltage	2			2			V
V _{IL} Low-level input voltage			0.7			0.8	V
I _{OH} High-level output current			-0.4			-0.4	mA
I _{OL} Low-level output current			4			8	mA
T _A Operating free-air temperature	-55		125	0		70	°C

electrical characteristics over recommended operating free-air temperature range (unless otherwise noted)

PARAMETER	TEST CONDITIONS †	SN54LS08		SN74LS08		UNIT		
		MIN	TYP‡	MAX	MIN		TYP‡	MAX
V _{IK}	V _{CC} = MIN, I _I = -18 mA			-1.5		-1.5	V	
V _{OH}	V _{CC} = MIN, V _{IH} = 2 V, I _{OH} = -0.4 mA	2.5	3.4	2.7	3.4		V	
V _{OL}	V _{CC} = MIN, V _{IL} = MAX, I _{OL} = 4 mA	0.25	0.4	0.25	0.4		V	
	V _{CC} = MIN, V _{IL} = MAX, I _{OL} = 8 mA				0.35	0.5		
I _I	V _{CC} = MAX, V _I = 7 V			0.1		0.1	mA	
I _{IH}	V _{CC} = MAX, V _I = 2.7 V			20		20	μA	
I _{IL}	V _{CC} = MAX, V _I = 0.4 V			-0.4		-0.4	mA	
I _{OS} §	V _{CC} = MAX	-20		-100		-100	mA	
I _{CCH}	V _{CC} = MAX, V _I = 4.5 V		2.4	4.8		2.4	4.8	mA
I _{CCL}	V _{CC} = MAX, V _I = 0 V		4.4	8.8		4.4	8.8	mA

† For conditions shown as MIN or MAX, use the appropriate value specified under recommended operating conditions.

‡ All typical values are at V_{CC} = 5 V, T_A = 25°C

§ Not more than one output should be shorted at a time, and the duration of the short-circuit should not exceed one second.

switching characteristics, V_{CC} = 5 V, T_A = 25°C (see note 2)

PARAMETER	FROM (INPUT)	TO (OUTPUT)	TEST CONDITIONS		MIN	TYP	MAX	UNIT
t _{PLH}	A or B	Y	R _L = 2 kΩ,	C _L = 15 pF		8	15	ns
t _{PHL}						10	20	ns

NOTE 2: See General Information Section for load circuits and voltage waveforms.

TYPES SN54S08, SN74S08
QUADRUPLE 2-INPUT POSITIVE-AND GATES

recommended operating conditions

	SN54S08			SN74S08			UNIT
	MIN	NOM	MAX	MIN	NOM	MAX	
V _{CC} Supply voltage	4.5	5	5.5	4.75	5	5.25	V
V _{IH} High-level input voltage	2			2			V
V _{IL} Low-level input voltage	0.8			0.8			V
I _{OH} High-level output current	-1			-1			mA
I _{OL} Low-level output current	20			20			mA
T _A Operating free-air temperature	-55	125		0	70		°C

electrical characteristics over recommended operating free-air temperature range (unless otherwise noted)

PARAMETER	TEST CONDITIONS †	SN54S08			SN74S08			UNIT
		MIN	TYP‡	MAX	MIN	TYP‡	MAX	
V _{IK}	V _{CC} = MIN, I _I = -18 mA	-1.2			-1.2			V
V _{OH}	V _{CC} = MIN, V _{IH} = 2 V, I _{OH} = -1 mA	2.5	3.4		2.7	3.4	V	
V _{OL}	V _{CC} = MIN, V _{IL} = 0.8 V, I _{OL} = 20 mA	0.5			0.5			V
I _I	V _{CC} = MAX, V _I = 5.5 V	1			1			mA
I _{IH}	V _{CC} = MAX, V _I = 2.7 V	50			50			µA
I _{IL}	V _{CC} = MAX, V _I = 0.5 V	-2			-2			mA
I _{OS} §	V _{CC} = MAX	-40	-100		-40	-100		mA
I _{CCH}	V _{CC} = MAX, V _I = 4.5 V	18 32			18 32			mA
I _{CCL}	V _{CC} = MAX, V _I = 0 V	32 57			32 57			mA

† For conditions shown as MIN or MAX, use the appropriate value specified under recommended operating conditions.

‡ All typical values are at V_{CC} = 5 V, T_A = 25°C.

§ Not more than one output should be shorted at a time, and the duration of the short-circuit should not exceed one second.

switching characteristics, V_{CC} = 5 V, T_A = 25°C (see note 2)

PARAMETER	FROM (INPUT)	TO (OUTPUT)	TEST CONDITIONS	MIN	TYP	MAX	UNIT
t _{PLH}	A or B	Y	R _L = 280 Ω, C _L = 15 pF	4.5	7		ns
t _{PHL}				5	7.5		ns
t _{PLH}			R _L = 280 Ω, C _L = 50 pF	6			ns
t _{PHL}				7.5			ns

NOTE 2: See General Information Section for load circuits and voltage waveforms.

TTL DEVICES

TYPES SN5409, SN54LS09, SN54S09, SN7409, SN74LS09, SN74S09

QUADRUPLE 2-INPUT POSITIVE-AND GATES WITH OPEN-COLLECTOR OUTPUTS

REVISED DECEMBER 1983

- Package Options Include Both Plastic and Ceramic Chip Carriers in Addition to Plastic and Ceramic DIPs
- Dependable Texas Instruments Quality and Reliability

description

These devices contain four independent 2-input AND gates. The open-collector outputs require pull-up resistors to perform correctly. They may be connected to other open-collector outputs to implement active-low wired-OR or active-high wired-AND functions. Open-collector devices are often used to generate higher V_{OH} levels.

The SN5409, SN54LS09, and SN54S09 are characterized for operation over the full military temperature range of -55°C to 125°C . The SN7409, SN74LS09 and SN74S09 are characterized for operation from 0°C to 70°C .

FUNCTION TABLE (each gate)

INPUTS		OUTPUT
A	B	Y
H	H	H
L	X	L
X	L	L

logic diagram (each gate)



positive logic

$$Y = A \cdot B \text{ or } Y = \overline{\overline{A} + \overline{B}}$$

SN5409, SN54LS09, SN54S09 ... J OR W PACKAGE

SN7409 ... J OR N PACKAGE

SN74LS09, SN74S09 ... D, J OR N PACKAGE

(TOP VIEW)

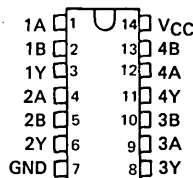

SN54LS09, SN54S09 ... FK PACKAGE

SN74LS09, SN74S09 ... FN PACKAGE

(TOP VIEW)

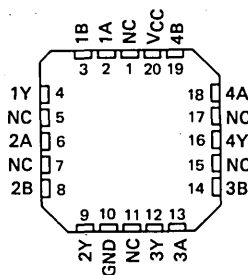

NC - No internal connection

TYPES SN5409, SN54LS09, SN54S09,
SN7409, SN74LS09, SN74S09

QUADRUPLE 2-INPUT POSITIVE-AND GATES WITH OPEN-COLLECTOR OUTPUTS

schematics (each gate)

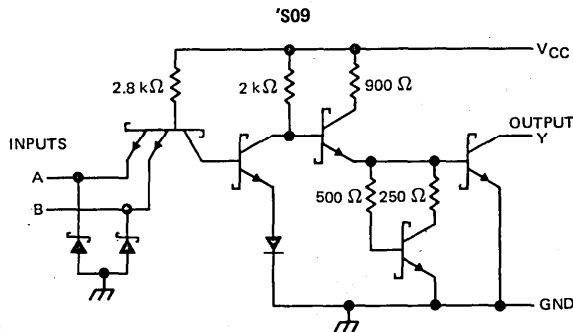
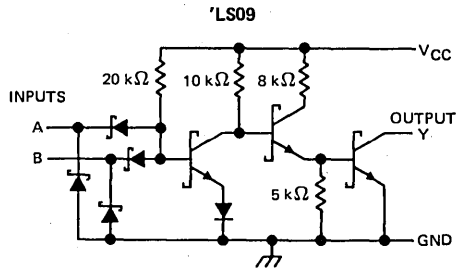
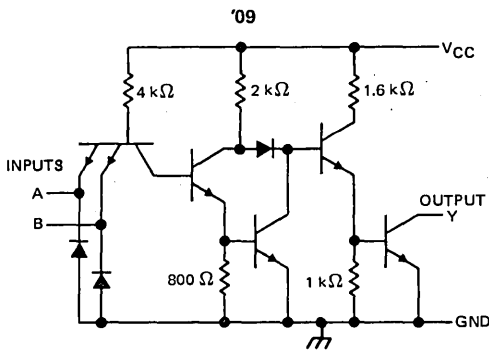

Resistor values shown are nominal.

absolute maximum ratings over operating free-air temperature range (unless otherwise noted)

Supply voltage, V_{CC} (see Note 1)	7 V
Input voltage: '09, 'S09	5.5 V
'LS09	7 V
Off-state output voltage	7 V
Operating free-air temperature range: SN54'	-55°C to 125°C
SN74'	0°C to 70°C
Storage temperature range	-65°C to 150°C

NOTE 1: Voltage values are with respect to network ground terminal.

3
TTL DEVICES

TYPES SN5409, SN7409

QUADRUPLE 2-INPUT POSITIVE-AND GATES WITH OPEN-COLLECTOR OUTPUTS

recommended operating conditions

	SN5409			SN7409			UNIT
	MIN	NOM	MAX	MIN	NOM	MAX	
V _{CC} Supply voltage	4.5	5	5.5	4.75	5	5.25	V
V _{IH} High-level input voltage	2			2			V
V _{IL} Low-level input voltage	0.8			0.8			V
V _{OH} High-level output voltage	5.5			5.5			V
I _{OL} Low-level output current	16			16			mA
T _A Operating free-air temperature	-55			125			0 70 °C

electrical characteristics over recommended operating free-air temperature range (unless otherwise noted)

PARAMETER	TEST CONDITION†	MIN	TYP‡	MAX	UNIT
V _{IK}	V _{CC} = MIN, I _I = -12 mA			-1.5	V
I _{OH}	V _{CC} = MIN, V _{IH} = 2 V, V _{OH} = 5.5 V			0.25	mA
V _{OL}	V _{CC} = MIN, V _{IL} = 0.8 V, I _{OL} = 16 mA		0.2	0.4	V
I _I	V _{CC} = MAX, V _I = 5.5 V			1	mA
I _{IH}	V _{CC} = MAX, V _I = 2.4 V			40	μA
I _{IL}	V _{CC} = MAX, V _I = 0.4 V			-1.6	mA
I _{CCH}	V _{CC} = MAX, V _I = 4.5 V		11	21	mA
I _{CCL}	V _{CC} = MAX, V _I = 0 V		20	33	mA

† For conditions shown as MIN or MAX, use the appropriate value specified under recommended operating conditions.

‡ All typical values are at V_{CC} = 5 V, T_A = 25°C.

switching characteristics, V_{CC} = 5 V, T_A = 25°C (see note 2)

PARAMETER	FROM (INPUT)	TO (OUTPUT)	TEST CONDITIONS	MIN	TYP	MAX	UNIT
t _{PLH}	A or B	Y	R _L = 400 Ω, C _L = 15 pF		21	32	ns
t _{PHL}					16	24	ns

NOTE 2: See General Information Section for load circuits and voltage waveforms.

3 TTL DEVICES

TYPES SN54LS09, SN74LS09
QUADRUPLE 2-INPUT POSITIVE-AND GATES WITH OPEN-COLLECTOR OUTPUTS

recommended operating conditions

	SN54LS09			SN74LS09			UNIT
	MIN	NOM	MAX	MIN	NOM	MAX	
V _{CC} Supply voltage	4.5	5	5.5	4.75	5	5.25	V
V _{IH} High-level input voltage	2			2			V
V _{IL} Low-level input voltage			0.7			0.8	V
V _{OH} High-level output voltage			5.5			5.5	V
I _{OL} Low-level output current			4			8	mA
T _A Operating free-air temperature	-55		125	0		70	°C

electrical characteristics over recommended operating free-air temperature range (unless otherwise noted)

PARAMETER	TEST CONDITIONS†	SN54LS09		SN74LS09		UNIT	
		MIN	TYP‡	MAX	MIN		TYP‡
V _{IK}	V _{CC} = MIN, I _I = -18 mA		-1.5		-1.5	V	
I _{OH}	V _{CC} = MIN, V _{IH} = 2 V, V _{OH} = 5.5 V		0.1		0.1	mA	
V _{OL}	V _{CC} = MIN, V _{IL} = MAX, I _{OL} = 4 mA		0.25	0.4	0.25	0.4	V
	V _{CC} = MIN, V _{IL} = MAX, I _{OL} = 8 mA				0.35	0.5	
I _I	V _{CC} = MAX, V _I = 7 V		0.1		0.1	mA	
I _{IH}	V _{CC} = MAX, V _I = 2.7 V		20		20	μA	
I _{IL}	V _{CC} = MAX, V _I = 0.4 V		-0.4		-0.4	mA	
I _{CCH}	V _{CC} = MAX, V _I = 4.5 V		2.4	4.8	2.4	4.8	mA
I _{CCL}	V _{CC} = MAX, V _I = 0 V		4.4	8.8	4.4	8.8	mA

† For conditions shown as MIN or MAX, use the appropriate value specified under recommended operating conditions.

‡ All typical values are at V_{CC} = 5 V, T_A = 25°C.

switching characteristics, V_{CC} = 5 V, T_A = 25°C (see note 2)

PARAMETER	FROM (INPUT)	TO (OUTPUT)	TEST CONDITIONS		MIN	TYP	MAX	UNIT
t _{PLH}	A or B	Y	R _L = 2 kΩ,	C _L = 15 pF		20	35	ns
t _{PHL}						17	35	ns

NOTE 2: See General Information Section for load circuits and voltage waveforms.

TTL DEVICES

TYPES SN54S09, SN74S09

QUADRUPLE 2-INPUT POSITIVE-AND GATES WITH OPEN-COLLECTOR OUTPUTS

recommended operating conditions

	SN54S09			SN74S09			UNIT		
	MIN	NOM	MAX	MIN	NOM	MAX			
V _{CC} Supply voltage	4.5	5	5.5	4.75	5	5.25	V		
V _{IH} High-level input voltage	2			2			V		
V _{IL} Low-level input voltage	0.8			0.8			V		
V _{OH} High-level output voltage	5.5			5.5			V		
I _{OL} Low-level output current	20			20			mA		
T _A Operating free-air temperature	-55			125			0	70	°C

electrical characteristics over recommended operating free-air temperature range (unless otherwise noted)

PARAMETER	TEST CONDITIONS†	MIN	TYP‡	MAX	UNIT
V _{IK}	V _{CC} = MIN, I _I = -18 mA		-1.2		V
I _{OH}	V _{CC} = MIN, V _{IH} = 2 V, V _{OH} = 5.5 V		0.25		mA
V _{OL}	V _{CC} = MIN, V _{IL} = 0.8 V, I _{OL} = 20 mA		0.5		V
I _I	V _{CC} = MAX, V _I = 5.5 V		1		mA
I _{IH}	V _{CC} = MAX, V _I = 2.7 V		50		μA
I _{IL}	V _{CC} = MAX, V _I = 0.5 V		-2		mA
I _{CCH}	V _{CC} = MAX, V _I = 4.5 V		18	32	mA
I _{CCL}	V _{CC} = MAX, V _I = 0 V		32	57	mA

† For conditions shown as MIN or MAX, use the appropriate value specified under recommended operating conditions.

‡ All typical values are at V_{CC} = 5 V, T_A = 25°C.

switching characteristics, V_{CC} = 5 V, T_A = 25°C (see note 2)

PARAMETER	FROM (INPUT)	TO (OUTPUT)	TEST CONDITIONS	MIN	TYP	MAX	UNIT
t _{PLH}	A or B	Y	R _L = 280 Ω, C _L = 15 pF	6.5	10		ns
t _{PHL}				6.5	10		ns
t _{PLH}			R _L = 280 Ω, C _L = 50 pF	9			ns
t _{PHL}				9			ns

NOTE 2: See General Information Section for load circuits and voltage waveforms.

TYPES SN5410, SN54H10, SN54L10, SN54LS10, SN54S10, SN7410, SN74H10, SN74LS10, SN74S10 TRIPLE 3-INPUT POSITIVE-NAND GATES

REVISED DECEMBER 1983

- Package Options Include Both Plastic and Ceramic Chip Carriers in Addition to Plastic and Ceramic DIPs
- Dependable Texas Instruments Quality and Reliability

description

These devices contain three independent 3-input NAND gates.

The SN5410, SN54H10, SN54L10, SN54LS10 and SN54S10 are characterized for operation over the full military temperature range of -55°C to 125°C . The SN7410, SN74H10, SN74LS10 and SN74S10 are characterized for operation from 0°C to 70°C .

FUNCTION TABLE (each gate)

INPUTS			OUTPUT
A	B	C	Y
H	H	H	L
L	X	X	H
X	L	X	H
X	X	L	H

logic diagram (each gate)



positive logic

$$Y = \overline{A \cdot B \cdot C} \text{ or } Y = \overline{A} + \overline{B} + \overline{C}$$

SN5410, SN54H10, SN54L10 ... J PACKAGE
SN54LS10, SN54S10 ... J OR W PACKAGE
SN7410, SN74H10 ... J OR N PACKAGE
SN74LS10, SN74S10 ... D, J OR N PACKAGE

(TOP VIEW)

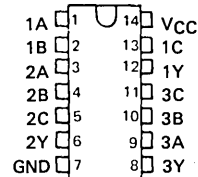

SN5410, SN54H10 ... W PACKAGE

(TOP VIEW)

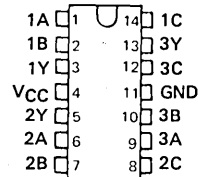

SN54LS10, SN54S10 ... FK PACKAGE
SN74LS10, SN74S10 ... FN PACKAGE

(TOP VIEW)

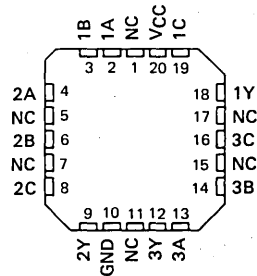

NC - No internal connection

TTL DEVICES

PRODUCTION DATA

This document contains information current as of publication date. Products conform to specifications per the terms of Texas Instruments standard warranty. Production processing does not necessarily include testing of all parameters.



TYPES SN5410, SN7410 TRIPLE 3-INPUT POSITIVE-NAND GATES

recommended operating conditions

	SN5410			SN7410			UNIT
	MIN	NOM	MAX	MIN	NOM	MAX	
V_{CC} Supply voltage	4.5	5	5.5	4.75	5	5.25	V
V_{IH} High-level input voltage	2			2			V
V_{IL} Low-level input voltage			0.8			0.8	V
I_{OH} High-level output current			-0.4			-0.4	mA
I_{OL} Low-level output current			16			16	mA
T_A Operating free-air temperature	-55		125	0		70	°C

electrical characteristics over recommended operating free-air temperature range (unless otherwise noted)

PARAMETER	TEST CONDITIONS †	SN5410			SN7410			UNIT
		MIN	TYP ‡	MAX	MIN	TYP ‡	MAX	
V_{IK}	$V_{CC} = \text{MIN}, I_I = -12 \text{ mA}$		-1.5			-1.5		V
V_{OH}	$V_{CC} = \text{MIN}, V_{IL} = 0.8 \text{ V}, I_{OH} = -0.4 \text{ mA}$	2.4	3.4		2.4	3.4		V
V_{OL}	$V_{CC} = \text{MIN}, V_{IH} = 2 \text{ V}, I_{OL} = 16 \text{ mA}$		0.2	0.4		0.2	0.4	V
I_I	$V_{CC} = \text{MAX}, V_I = 5.5 \text{ V}$			1			1	mA
I_{IH}	$V_{CC} = \text{MAX}, V_I = 2.4 \text{ V}$			40			40	µA
I_{IL}	$V_{CC} = \text{MAX}, V_I = 0.4 \text{ V}$			-1.6			-1.6	mA
$I_{OS} §$	$V_{CC} = \text{MAX}$	-20		-55	-18		-55	mA
I_{CCH}	$V_{CC} = \text{MAX}, V_I = 0 \text{ V}$		3	6		3	6	mA
I_{CCL}	$V_{CC} = \text{MAX}, V_I = 4.5 \text{ V}$		9	16.5		9	16.5	mA

† For conditions shown as MIN or MAX, use the appropriate value specified under recommended operating conditions.

‡ All typical values are at $V_{CC} = 5 \text{ V}, T_A = 25^\circ\text{C}$.

§ Not more than one output should be shorted at a time.

switching characteristics, $V_{CC} = 5 \text{ V}, T_A = 25^\circ\text{C}$ (see note 2)

PARAMETER	FROM (INPUT)	TO (OUTPUT)	TEST CONDITIONS		MIN	TYP	MAX	UNIT
t_{PLH}	A, B or C	Y	$R_L = 400 \Omega,$	$C_L = 15 \text{ pF}$		11	22	ns
t_{PHL}						7	15	ns

NOTE 2: See General Information Section for load circuits and voltage waveforms.

3
TTL DEVICES

TYPES SN54H10, SN74H10 TRIPLE 3-INPUT POSITIVE-NAND GATES

recommended operating conditions

	SN54H10			SN74H10			UNIT
	MIN	NOM	MAX	MIN	NOM	MAX	
V _{CC} Supply voltage	4.5	5	5.5	4.75	5	5.25	V
V _{IH} High-level input voltage	2			2			V
V _{IL} Low-level input voltage	0.8			0.8			V
I _{OH} High-level output current	-0.5			-0.5			mA
I _{OL} Low-level output current	20			20			mA
T _A Operating free-air temperature	-55			0			70 °C

electrical characteristics over recommended operating free-air temperature range (unless otherwise noted)

PARAMETER	TEST CONDITIONS †	MIN	TYP ‡	MAX	UNIT
V _{IK}	V _{CC} = MIN, I _I = -8 mA	-1.5			V
V _{OH}	V _{CC} = MIN, V _{IL} = 0.8 V, I _{OH} = -0.5 mA	2.4	3.5		V
V _{OL}	V _{CC} = MIN, V _{IH} = 2 V, I _{OL} = 20 mA	0.2	0.4		V
I _I	V _{CC} = MAX, V _I = 5.5 V	1			mA
I _{IH}	V _{CC} = MAX, V _I = 2.4 V	50			µA
I _{IL}	V _{CC} = MAX, V _I = 0.4 V	-2			mA
I _{OS} §	V _{CC} = MAX	-40		-100	mA
I _{CCH}	V _{CC} = MAX, V _I = 0 V	7.5			12.6 mA
I _{CCL}	V _{CC} = MAX, V _I = 4.5 V	19.5			30 mA

† For conditions shown as MIN or MAX, use the appropriate value specified under recommended operating conditions.

‡ All typical values are at V_{CC} = 5 V, T_A = 25°C.

§ Not more than one output should be shorted at a time, and the duration of the short-circuit should not exceed one second.

switching characteristics, V_{CC} = 5 V, T_A = 25°C (see note 2)

PARAMETER	FROM (INPUT)	TO (OUTPUT)	TEST CONDITIONS	MIN	TYP	MAX	UNIT
t _{PLH}	A, B or C	Y	R _L = 280 Ω, C _L = 25 pF	5.9		10	ns
t _{PHL}				6.3		10	ns

NOTE 2: See General Information Section for load circuits and voltage waveforms.

3

TTL DEVICES

TYPE SN54L10 TRIPLE 3-INPUT POSITIVE-NAND GATES

recommended operating conditions

	SN54L10			UNIT
	MIN	NOM	MAX	
V _{CC} Supply voltage	4.5	5	5.5	V
V _{IH} High-level input voltage	2			V
V _{IL} Low-level input voltage			0.7	V
I _{OH} High-level output current			-0.1	mA
I _{OL} Low-level output current			2	mA
T _A Operating free-air temperature	-55		125	°C

electrical characteristics over recommended operating free-air temperature range (unless otherwise noted)

PARAMETER	TEST CONDITIONS †	SN54L10			UNIT
		MIN	TYP ‡	MAX	
V _{OH}	V _{CC} = MIN, V _{IL} = 0.7 V, I _{OH} = -0.1 mA	2.4	3.3		V
V _{OL}	V _{CC} = MIN, V _{IH} = 2 V, I _{OL} = 2 mA		0.15	0.3	V
I _I	V _{CC} = MAX, V _I = 5.5 V			0.1	mA
I _{IH}	V _{CC} = MAX, V _I = 2.4 V			10	μA
I _{IL}	V _{CC} = MAX, V _I = 0.3 V			-0.18	mA
I _{OS} §	V _{CC} = MAX	-3		-15	mA
I _{CCH}	V _{CC} = MAX, V _I = 0 V		0.33	0.6	mA
I _{CCL}	V _{CC} = MAX, V _I = 4.5 V		0.87	1.53	mA

† For conditions shown as MIN or MAX, use the appropriate value specified under recommended operating conditions.

‡ All typical values are at V_{CC} = 5 V, T_A = 25°C.

§ Not more than one output should be shorted at a time.

switching characteristics, V_{CC} = 5 V, T_A = 25°C (see note 2)

PARAMETER	FROM (INPUT)	TO (OUTPUT)	TEST CONDITIONS	MIN	TYP	MAX	UNIT
t _{PLH}	A, B or C	Y	R _L = 4 kΩ, C _L = 50 pF		35	60	ns
t _{PHL}					31	60	ns

NOTE 2: See General Information Section for load circuits and voltage waveforms.

TTL DEVICES

TYPE SN54LS10, SN74LS10

TRIPLE 3-INPUT POSITIVE-NAND GATES

recommended operating conditions

	SN54LS10			SN74LS10			UNIT
	MIN	NOM	MAX	MIN	NOM	MAX	
V _{CC} Supply voltage	4.5	5	5.5	4.75	5	5.25	V
V _{IH} High-level input voltage	2			2			V
V _{IL} Low-level input voltage			0.7			0.8	V
I _{OH} High-level output current			-0.4			-0.4	mA
I _{OL} Low-level output current			4			8	mA
T _A Operating free-air temperature	-55		125	0		70	°C

electrical characteristics over recommended operating free-air temperature range (unless otherwise noted)

PARAMETER	TEST CONDITIONS †	SN54LS10		SN74LS10		UNIT		
		MIN	TYP‡	MAX	MIN		TYP‡	MAX
V _{IK}	V _{CC} = MIN, I _I = -18 mA			-1.5		-1.5	V	
V _{OH}	V _{CC} = MIN, V _{IL} = MAX, I _{OH} = -0.4 mA	2.5	3.4	2.7	3.4		V	
V _{OL}	V _{CC} = MIN, V _{IH} = 2 V, I _{OL} = 4 mA		0.25	0.4		0.4	V	
	V _{CC} = MIN, V _{IH} = 2 V, I _{OL} = 8 mA				0.25	0.5		
I _I	V _{CC} = MAX, V _I = 7 V			0.1		0.1	μA	
I _{IH}	V _{CC} = MAX, V _I = 2.7 V			20		20	μA	
I _{IL}	V _{CC} = MAX, V _I = 0.4 V			-0.4		-0.4	mA	
I _{OS} §	V _{CC} = MAX	-20		-100	-20	-100	mA	
I _{CCH}	V _{CC} = MAX, V _I = 0 V		0.6	1.2		0.6	1.2	mA
I _{CCL}	V _{CC} = MAX, V _I = 4.5 V		1.8	3.3		1.8	3.3	mA

† For conditions shown as MIN or MAX, use the appropriate value specified under recommended operating conditions.

‡ All typical values are at V_{CC} = 5 V, T_A = 25°C.

§ Not more than one output should be shorted at a time, and the duration of the short-circuit should not exceed one second.

switching characteristics, V_{CC} = 5 V, T_A = 25°C (see note 2)

PARAMETER	FROM (INPUT)	TO (OUTPUT)	TEST CONDITIONS		MIN	TYP	MAX	UNIT
t _{PLH}	A, B or C	Y	R _L = 2 kΩ,	C _L = 15 pF		9	15	ns
t _{PHL}						10	15	ns

NOTE 2: See General Information Section for load circuits and voltage waveforms.

TYPES SN54S10, SN74S10 TRIPLE 3-INPUT POSITIVE-NAND GATES

recommended operating conditions

	SN54S10			SN74S10			UNIT
	MIN	NOM	MAX	MIN	NOM	MAX	
V_{CC} Supply voltage	4.5	5	5.5	4.75	5	5.25	V
V_{IH} High-level input voltage	2			2			V
V_{IL} Low-level input voltage			0.8			0.8	V
I_{OH} High-level output current			-1			-1	mA
I_{OL} Low-level output current			20			20	mA
T_A Operating free-air temperature	-55		125	0		70	°C

electrical characteristics over recommended operating free-air temperature range (unless otherwise noted)

PARAMETER	TEST CONDITIONS †	SN54S10			SN74S10			UNIT
		MIN	TYP ‡	MAX	MIN	TYP ‡	MAX	
V_{IK}	$V_{CC} = \text{MIN}$, $I_I = -18 \text{ mA}$			-1.2			-1.2	V
V_{OH}	$V_{CC} = \text{MIN}$, $V_{IL} = 0.8 \text{ V}$, $I_{OH} = -1 \text{ mA}$	2.5	3.4		2.7	3.4		V
V_{OL}	$V_{CC} = \text{MIN}$, $V_{IH} = 2 \text{ V}$, $I_{OL} = 20 \text{ mA}$			0.5			0.5	V
I_I	$V_{CC} = \text{MAX}$, $V_I = 5.5 \text{ V}$			1			1	mA
I_{IH}	$V_{CC} = \text{MAX}$, $V_I = 2.7 \text{ V}$			50			50	μA
I_{IL}	$V_{CC} = \text{MAX}$, $V_I = 0.5 \text{ V}$			-2			-2	mA
$I_{OS} §$	$V_{CC} = \text{MAX}$	-40		-100	-40		-100	mA
I_{CCH}	$V_{CC} = \text{MAX}$, $V_I = 0 \text{ V}$		7.5	12		7.5	12	mA
I_{CCL}	$V_{CC} = \text{MAX}$, $V_I = 4.5 \text{ V}$		15	27		15	27	mA

† For conditions shown as MIN or MAX, use the appropriate value specified under recommended operating conditions.

‡ All typical values are at $V_{CC} = 5 \text{ V}$, $T_A = 25^\circ\text{C}$.

§ Not more than one output should be shorted at a time, and the duration of the short-circuit should not exceed one second.

switching characteristics, $V_{CC} = 5 \text{ V}$, $T_A = 25^\circ\text{C}$ (see note 2)

PARAMETER	FROM (INPUT)	TO (OUTPUT)	TEST CONDITIONS		MIN	TYP	MAX	UNIT
t_{PLH}	A, B or C	Y	$R_L = 280 \Omega$,	$C_L = 15 \text{ pF}$		3	4.5	ns
t_{PHL}						3	5	ns
t_{PLH}			$R_L = 280 \Omega$,	$C_L = 50 \text{ pF}$		4.5		ns
t_{PHL}						5		ns

NOTE 2: See General Information Section for load circuits and voltage waveforms.

3

TTL DEVICES

TYPES SN54H11, SN54LS11, SN54S11, SN74H11, SN74LS11, SN74S11 TRIPLE 3-INPUT POSITIVE-AND GATES

REVISED APRIL 1985

- Package Options Include Both Plastic and Ceramic Chip Carriers in Addition to Plastic and Ceramic DIPs
- Dependable Texas Instruments Quality and Reliability

description

These devices contain three independent 3-input AND gates.

The SN54H11, SN54LS11, SN54S11 are characterized for operation over the full military temperature range of -55°C to 125°C . The SN74H11, SN74LS11, and SN74S11, are characterized for operation from 0°C to 70°C .

FUNCTION TABLE (each gate)

INPUTS			OUTPUT
A	B	C	Y
H	H	H	H
L	X	X	L
X	L	X	L
X	X	L	L

logic diagram (each gate)



positive logic

$$Y = A \cdot B \cdot C \text{ or } Y = \overline{\overline{A} + \overline{B} + \overline{C}}$$

SN54H11 ... J PACKAGE
SN54LS11, SN54S11 ... J OR W PACKAGE
SN74H11 ... J OR N PACKAGE
SN74LS11, SN74S11 ... D, J OR N PACKAGE

(TOP VIEW)

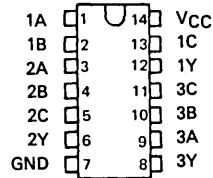

SN54H11 ... W PACKAGE
(TOP VIEW)

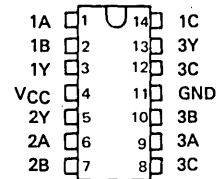

SN54LS11, SN54S11 ... FK PACKAGE
SN74LS11, SN74S11 ... FN PACKAGE

(TOP VIEW)

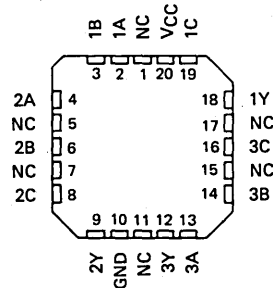

NC - No internal connection

3

TTL DEVICES

PRODUCTION DATA

This document contains information current as of publication date. Products conform to specifications per the terms of Texas Instruments standard warranty. Production processing does not necessarily include testing of all parameters.

TEXAS
INSTRUMENTS

POST OFFICE BOX 225012 • DALLAS, TEXAS 75265

**TYPES SN54H11, SN54LS11, SN54S11
SN74H11, SN74LS11, SN74S11
TRIPLE 3-INPUT POSITIVE-AND GATES**

schematics (each gate)

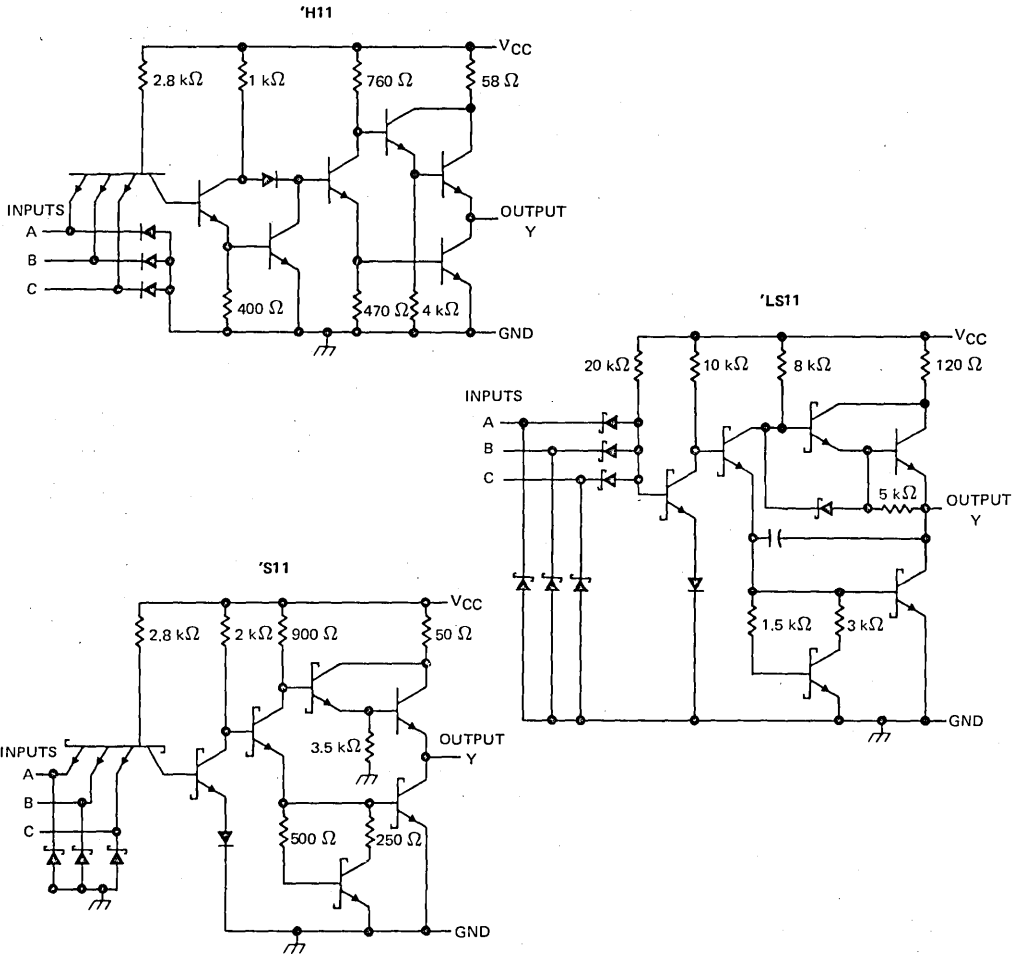

Resistor values shown are nominal.

absolute maximum ratings over operating free-air temperature range (unless otherwise noted)

Supply voltage, V_{CC} (see Note 1)	7 V
Input voltage: 'H11, 'S11	5.5 V
'LS11	7 V
Operating free-air temperature: SN54'	-55°C to 125°C
SN74'	0°C to 70°C
Storage temperature range	-65°C to 150°C

NOTE 1: Voltage values are with respect to network ground terminal.

TTL DEVICES

TYPES SN54H11, SN74H11

TRIPLE 3-INPUT POSITIVE-AND GATES

recommended operating conditions

	SN54H11			SN74H11			UNIT
	MIN	NOM	MAX	MIN	NOM	MAX	
V_{CC} Supply voltage	4.5	5	5.5	4.75	5	5.25	V
V_{IH} High-level input voltage	2			2			V
V_{IL} Low-level input voltage	0.8			0.8			V
I_{OH} High-level output current	-0.5			-0.5			mA
I_{OL} Low-level output current	20			20			mA
T_A Operating free-air temperature	-55			0			70 °C

electrical characteristics over recommended operating free-air temperature range (unless otherwise noted)

PARAMETER	TEST CONDITIONS †	SN54H11			SN74H11			UNIT	
		MIN	TYP ‡	MAX	MIN	TYP ‡	MAX		
V_{IK}	$V_{CC} = \text{MIN}, I_I = -8 \text{ mA}$	-1.5			-1.5			V	
V_{OH}	$V_{CC} = \text{MIN}, V_{IH} = 2 \text{ V}, I_{OH} = -0.5 \text{ mA}$	2.4	3.4		2.4	3.4		V	
V_{OL}	$V_{CC} = \text{MIN}, V_{IL} = 0.8 \text{ V}, I_{OL} = 20 \text{ mA}$	0.2			0.2			V	
I_I	$V_{CC} = \text{MAX}, V_I = 5.5 \text{ V}$	1			1			mA	
I_{IH}	$V_{CC} = \text{MAX}, V_I = 2.4 \text{ V}$	50			50			µA	
I_{IL}	$V_{CC} = \text{MAX}, V_I = 0.4 \text{ V}$	-2			-2			mA	
$I_{OS} §$	$V_{CC} = \text{MAX}$	-40		-100	-40		-100	mA	
I_{CCH}	$V_{CC} = \text{MAX}, V_I = 4.5 \text{ V}$	18			18			30	mA
I_{CCL}	$V_{CC} = \text{MAX}, V_I = 0 \text{ V}$	30			30			48	mA

† For conditions shown as MIN or MAX, use the appropriate value specified under recommended operating conditions.

‡ All typical values are at $V_{CC} = 5 \text{ V}, T_A = 25^\circ\text{C}$.

§ Not more than one output should be shorted at a time, and the duration of the output short circuit should not exceed one second.

switching characteristics, $V_{CC} = 5 \text{ V}, T_A = 25^\circ\text{C}$ (see note 2)

PARAMETER	FROM (INPUT)	TO (OUTPUT)	TEST CONDITIONS	MIN	TYP	MAX	UNIT
t_{PLH}	A, B or C	Y	$R_L = 280 \Omega, C_L = 25 \text{ pF}$	7.6		12	ns
t_{PHL}				8.8		12	ns

NOTE 2: See General Information Section for load circuits and voltage waveforms.

3

TTL DEVICES

TYPES SN54LS11, SN74LS11

TRIPLE 3-INPUT POSITIVE-AND GATES

recommended operating conditions

	SN54LS11			SN74LS11			UNIT
	MIN	NOM	MAX	MIN	NOM	MAX	
V _{CC} Supply voltage	4.5	5	5.5	4.75	5	5.25	V
V _{IH} High-level input voltage	2			2			V
V _{IL} Low-level input voltage	0.7			0.8			V
I _{OH} High-level output current	-0.4			-0.4			mA
I _{OL} Low-level output current	4			8			mA
T _A Operating free-air temperature	-55		125	0		70	°C

electrical characteristics over recommended operating free-air temperature range (unless otherwise noted)

PARAMETER	TEST CONDITIONS †	SN54LS11		SN74LS11		UNIT
		MIN	TYP ‡	MAX	MIN	
V _{IK}	V _{CC} = MIN, I _I = -18 mA	-1.5		-1.5		V
V _{OH}	V _{CC} = MIN, V _{IH} = 2 V, I _{OH} = -0.4 mA	2.5	3.4	2.7	3.4	V
V _{OL}	V _{CC} = MIN, V _{IL} = MAX, I _{OL} = 4 mA	0.25 0.4		0.25 0.4		V
	V _{CC} = MIN, V _{IL} = MAX, I _{OL} = 8 mA			0.35 0.5		
I _I	V _{CC} = MAX, V _I = 7 V	0.1		0.1		mA
I _{IH}	V _{CC} = MAX, V _I = 2.7 V	20		20		µA
I _{IL}	V _{CC} = MAX, V _I = 0.4 V	-0.4		-0.4		mA
I _{OS} §	V _{CC} = MAX	-20	-100	-20	-100	mA
I _{CCH}	V _{CC} = MAX, V _I = 4.5 V	1.8 3.6		1.8 3.6		mA
I _{CCL}	V _{CC} = MAX, V _I = 0 V	3.3 6.6		3.3 6.6		mA

† For conditions shown as MIN or MAX, use the appropriate value specified under recommended operating conditions.

‡ All typical values are at V_{CC} = 5 V, T_A = 25°C.

§ Not more than one output should be shorted at a time, and the duration of the short-circuit should not exceed one second.

switching characteristics, V_{CC} = 5 V, T_A = 25°C (see note 2)

PARAMETER	FROM (INPUT)	TO (OUTPUT)	TEST CONDITIONS		MIN	TYP	MAX	UNIT
t _{PLH}	A, B or C	Y	R _L = 2 kΩ,	C _L = 15 pF	8		15	ns
t _{PHL}					10		20	ns

NOTE 2: See General Information Section for load circuits and voltage waveforms.

TYPES SN54S11, SN74S11 TRIPLE 3-INPUT POSITIVE-AND GATES

recommended operating conditions

	SN54S11			SN74S11			UNIT
	MIN	NOM	MAX	MIN	NOM	MAX	
V_{CC} Supply voltage	4.5	5	5.5	4.75	5	5.25	V
V_{IH} High-level input voltage	2			2			V
V_{IL} Low-level input voltage	0.8			0.8			V
I_{OH} High-level output current	-1			-1			mA
I_{OL} Low-level output current	20			20			mA
T_A Operating free-air temperature	-55			0			70 °C

electrical characteristics over recommended operating free-air temperature range (unless otherwise noted)

PARAMETER	TEST CONDITIONS †	SN54S11		SN74S11		UNIT
		MIN	TYP ‡	MAX	MIN	
V_{IK}	$V_{CC} = \text{MIN}, I_I = -18 \text{ mA}$	-1.2		-1.2		V
V_{OH}	$V_{CC} = \text{MIN}, V_{IH} = 2 \text{ V}, I_{OH} = -1 \text{ mA}$	2.5	3.4	2.7	3.4	V
V_{OL}	$V_{CC} = \text{MIN}, V_{IL} = 0.8 \text{ V}, I_{OL} = 20 \text{ mA}$	0.5		0.5		V
I_I	$V_{CC} = \text{MAX}, V_I = 5.5 \text{ V}$	1		1		mA
I_{IH}	$V_{CC} = \text{MAX}, V_I = 2.7 \text{ V}$	50		50		μA
I_{IL}	$V_{CC} = \text{MAX}, V_I = 0.5 \text{ V}$	-2		-2		mA
$I_{OS} §$	$V_{CC} = \text{MAX}$	-40	-100	-40	-100	mA
I_{CCH}	$V_{CC} = \text{MAX}, V_I = 4.5 \text{ V}$	13.5	24	13.5	24	mA
I_{CCL}	$V_{CC} = \text{MAX}, V_I = 0 \text{ V}$	24	42	24	42	mA

† For conditions shown as MIN or MAX, use the appropriate value specified under recommended operating conditions.

‡ All typical values are at $V_{CC} = 5 \text{ V}, T_A = 25^\circ\text{C}$.

§ Not more than one output should be shorted at a time, and the duration of the short-circuit should not exceed one second.

switching characteristics, $V_{CC} = 5 \text{ V}, T_A = 25^\circ\text{C}$ (see note 2)

PARAMETER	FROM (INPUT)	TO (OUTPUT)	TEST CONDITIONS		MIN	TYP	MAX	UNIT
t_{PLH}	A, B or C	Y	$R_L = 280 \Omega,$	$C_L = 15 \text{ pF}$	4.5		7	ns
t_{PHL}					5		7.5	ns
t_{PLH}			$R_L = 280 \Omega,$	$C_L = 50 \text{ pF}$	6		ns	
t_{PHL}					7.5		ns	

NOTE 2: See General Information Section for load circuits and voltage waveforms.

TTL DEVICES

TYPES SN5412, SN54LS12 SN7412, SN74LS12 TRIPLE 3-INPUT POSITIVE-NAND GATES WITH OPEN-COLLECTOR OUTPUTS

REVISED DECEMBER 1983

- Package Options Include Both Plastic and Ceramic Chip Carriers in Addition to Plastic and Ceramic DIPs
- Dependable Texas Instruments Quality and Reliability

description

These devices contain three independent 3-input NAND gates with open-collector outputs. The open-collector outputs require pull-up resistors to perform correctly. They may be connected to other open-collector outputs to implement active-low wired-OR or active-high wired-AND functions. Open-collector devices are often used to generate higher V_{OH} levels.

The SN5412 and SN54LS12 are characterized for operation over the full military range of -55°C to 125°C . The SN7412 and SN74LS12 are characterized for operation from 0°C to 70°C .

FUNCTION TABLE (each gate)

INPUTS			OUTPUT
A	B	C	Y
H	H	H	L
L	X	X	H
X	L	X	H
X	X	L	H

logic diagram (each gate)



positive logic

$$Y = \overline{A \cdot B \cdot C} \text{ or } Y = \overline{A + B + C}$$

SN5412, SN54LS12 ... J OR W PACKAGE
SN7412 ... J OR N PACKAGE
SN74LS12 ... D, J OR N PACKAGE
(TOP VIEW)

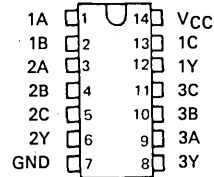

SN54LS12 ... FK PACKAGE
SN74LS12 ... FN PACKAGE
(TOP VIEW)

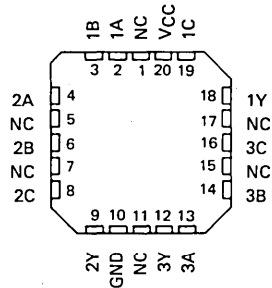

NC - No internal connection

6

TTL DEVICES

TYPES SN5412, SN54LS12
SN7412, SN74LS12

TRIPLE 3-INPUT POSITIVE-NAND GATES WITH OPEN-COLLECTOR OUTPUTS

schematics (each gate)

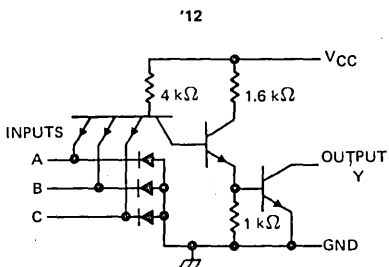

Resistor values shown are nominal.

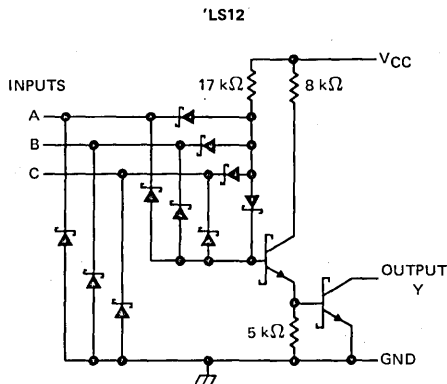

absolute maximum ratings over operating free-air temperature range (unless otherwise noted)

Supply voltage, V_{CC} (see Note 1)	7 V
Input voltage: '12	5.5 V
'LS12	7 V
Off-state output voltage	7 V
Operating free-air temperature: SN54'	-55°C to 125°C
SN74'	0°C to 70°C
Storage temperature range	-65°C to 150°C

NOTE 1: Voltage values are with respect to network ground terminal.



TTL DEVICES

TYPES SN5412, SN7412
TRIPLE 3-INPUT POSITIVE-NAND GATES WITH OPEN-COLLECTOR OUTPUTS

recommended operating conditions

	SN5412			SN7412			UNIT
	MIN	NOM	MAX	MIN	NOM	MAX	
V _{CC} Supply voltage	4.5	5	5.5	4.75	5	5.25	V
V _{IH} High-level input voltage	2			2			V
V _{IL} Low-level input voltage			0.8			0.8	V
V _{OH} High-level output voltage			5.5			5.5	V
I _{OL} Low-level output current			16			16	mA
T _A Operating free-air temperature	-55		125	0		70	°C

electrical characteristics over recommended operating free-air temperature range (unless otherwise noted)

PARAMETER	TEST CONDITIONS†	MIN	TYP‡	MAX	UNIT
V _{IK}	V _{CC} = MIN, I _I = -12 mA			-1.5	V
I _{OH}	V _{CC} = MIN, V _{IL} = 0.8 V, V _{OH} = 5.5 V			0.25	mA
V _{OL}	V _{CC} = MIN, V _{IH} = 2 V, I _{OL} = 16 mA		0.2	0.4	V
I _I	V _{CC} = MAX, V _I = 5.5 V			1	mA
I _{IH}	V _{CC} = MAX, V _I = 2.4 V			40	μA
I _{IL}	V _{CC} = MAX, V _I = 0.4 V			-1.6	mA
I _{CCH}	V _{CC} = MAX, V _I = 0 V		3	6	mA
I _{CCL}	V _{CC} = MAX, V _I = 4.5 V		9	16.5	mA

† For conditions shown as MIN or MAX, use the appropriate value specified under recommended operating conditions.

‡ All typical values are at V_{CC} = 5 V, T_A = 25°C.

switching characteristics, V_{CC} = 5 V, T_A = 25°C (see note 2)

PARAMETER	FROM (INPUT)	TO (OUTPUT)	TEST CONDITIONS	MIN	TYP	MAX	UNIT
t _{PLH}	A, B or C	Y	R _L = 4 kΩ, C _L = 15 pF	35	45	ns	
t _{PHL}			R _L = 400 Ω, C _L = 15 pF	8	15	ns	

NOTE 2: See General Information Section for load circuits and voltage waveforms.

3

TTL DEVICES

TYPES SN54LS12, SN74LS12

TRIPLE 3-INPUT POSITIVE-NAND GATES WITH OPEN-COLLECTOR OUTPUTS

recommended operating conditions

	SN54LS12			SN74LS12			UNIT
	MIN	NOM	MAX	MIN	NOM	MAX	
V _{CC} Supply voltage	4.5	5	5.5	4.75	5	5.25	V
V _{IH} High-level input voltage	2			2			V
V _{IL} Low-level input voltage			0.7			0.8	V
V _{OH} High-level output voltage			5.5			5.5	V
I _{OL} Low-level output current			4			8	mA
T _A Operating free-air temperature	-55		125	0		70	°C

electrical characteristics over recommended operating free-air temperature range (unless otherwise noted)

PARAMETER	TEST CONDITIONS†	SN54LS12		SN74LS12		UNIT
		MIN	TYP‡	MAX	MIN	
V _{IK}	V _{CC} = MIN, I _I = -18 mA		-1.5		-1.5	V
I _{OH}	V _{CC} = MIN, V _{IL} = MAX, V _{OH} = 5.5 V		0.1		0.1	mA
V _{OL}	V _{CC} = MIN, V _{IH} = 2 V, I _{OL} = 4 mA	0.25	0.4	0.25	0.4	V
	V _{CC} = MIN, V _{IH} = 2 V, I _{OL} = 8 mA			0.35	0.5	
I _I	V _{CC} = MAX, V _I = 7 V		0.1		0.1	mA
I _{IH}	V _{CC} = MAX, V _I = 2.7 V		20		20	μA
I _{IL}	V _{CC} = MAX, V _I = 0.4 V		-0.4		-0.4	mA
I _{CCH}	V _{CC} = MAX, V _I = 0 V	0.7	1.4	0.7	1.4	mA
I _{CCL}	V _{CC} = MAX, V _I = 4.5 V	1.8	3.3	1.8	3.3	mA

† For conditions shown as MIN or MAX, use the appropriate value specified under recommended operating conditions.

‡ All typical values are at V_{CC} = 5 V, T_A = 25°C.

switching characteristics, V_{CC} = 5 V, T_A = 25°C (see note 2)

PARAMETER	FROM (INPUT)	TO (OUTPUT)	TEST CONDITIONS		MIN	TYP	MAX	UNIT
t _{PLH}	A, B or C	Y	R _L = 2 kΩ,	C _L = 15 pF		17	32	ns
t _{PHL}						15	28	ns

NOTE 2: See General Information Section for load circuits and voltage waveforms.



TTL DEVICES

TYPES SN5413, SN54LS13, SN7413, SN74LS13 DUAL 4-INPUT POSITIVE-NAND SCHMITT TRIGGERS

REVISED DECEMBER 1983

- Operation from Very Slow Edges
- Improved Line-Receiving Characteristics
- High Noise Immunity

SN5413, SN54LS13 ... J OR W PACKAGE
SN7413 ... J OR N PACKAGE
SN74LS13 ... D, J OR N PACKAGE
(TOP VIEW)

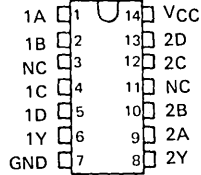

SN54LS13 ... FK PACKAGE
SN74LS13 ... FN PACKAGE
(TOP VIEW)

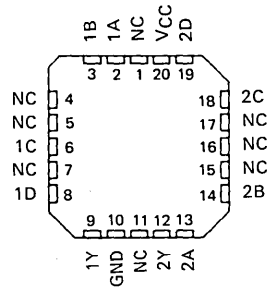

NC - No internal connection

description

Each circuit functions as a 4-input NAND gate, but because of the Schmitt action, it has different input threshold levels for positive (V_{T+}) and for negative going (V_{T-}) signals.

These circuits are temperature-compensated and can be triggered from the slowest of input ramps and still give clean, jitter-free output signals.

The SN5413 and SN54LS13 are characterized for operation over the full military temperature range of -55°C to 125°C . The SN7413 and SN74LS13 are characterized for operation from 0°C to 70°C .

logic diagram

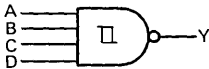

positive logic

$$Y = \overline{ABCD}$$

TTL DEVICES

TYPES SN5413, SN54LS13, SN7413, SN74LS13
DUAL 4-INPUT
POSITIVE-NAND SCHMITT TRIGGERS

schematics

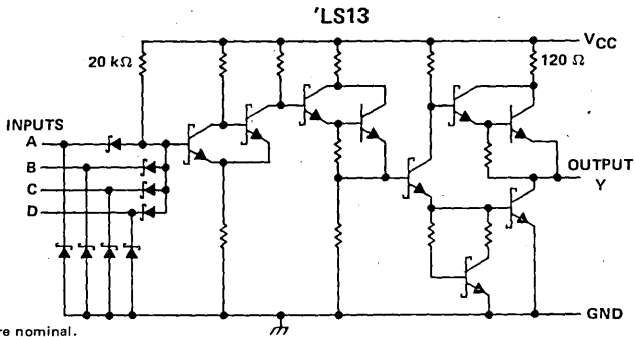
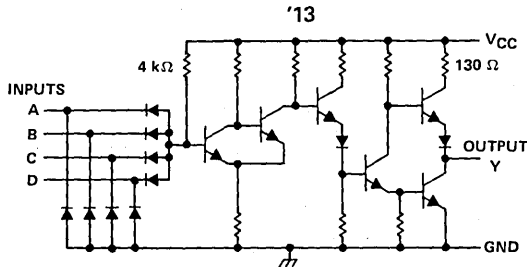

Resistor values are nominal.

absolute maximum ratings over operating free-air temperature range (unless otherwise noted)

Supply voltage, V_{CC} (see Note 1)	7 V
Input voltage: '13	5.5 V
'LS13	7 V
Operating free-air temperature: SN54'	-55°C to 125°C
SN74'	0°C to 70°C
Storage temperature range	-65°C to 150°C

NOTE 1: Voltage values are with respect to network ground terminal.

3 TTL DEVICES

TYPES SN5413, SN7413
DUAL 4-INPUT
POSITIVE-NAND SCHMITT TRIGGERS

recommended operating conditions

	SN5413			SN7413			UNIT
	MIN	NOM	MAX	MIN	NOM	MAX	
V _{CC} Supply voltage	4.5	5	5.5	4.75	5	5.25	V
I _{OH} High-level output current			-0.8			-0.8	mA
I _{OL} Low-level output current			16			16	mA
T _A Operating free-air temperature	-55		125	0		70	°C

electrical characteristics over recommended operating free-air temperature range (unless otherwise noted)

PARAMETER	TEST CONDITIONS†	MIN	TYP‡	MAX	UNIT
V _{T+}	V _{CC} = 5 V	1.5	1.7	2	V
V _{T-}	V _{CC} = 5 V	0.6	0.9	1.1	V
Hysteresis (V _{T+} - V _{T-})	V _{CC} = 5 V	0.4	0.8		V
V _{IK}	V _{CC} = MIN, I _I = -12 mA			-1.5	V
V _{OH}	V _{CC} = MIN, V _I = 0.6 V, I _{OH} = -0.8 mA	2.4	3.4		V
V _{OL}	V _{CC} = MIN, V _I = 2 V, I _{OL} = 16 mA		0.2	0.4	V
I _{T+}	V _{CC} = 5 V, V _I = V _{T+}		-0.65		mA
I _{T-}	V _{CC} = 5 V, V _I = V _{T-}		-0.85		mA
I _I	V _{CC} = MAX, V _I = 5.5 V			1	mA
I _{IH}	V _{CC} = MAX, V _{IH} = 2.4 V			40	μA
I _{IL}	V _{CC} = MAX, V _{IL} = 0.4 V		-1	-1.6	mA
I _{OS} §	V _{CC} = MAX,	-18		-55	mA
I _{CCH}	V _{CC} = MAX		14	23	mA
I _{CCL}	V _{CC} = MAX		20	32	mA

† For conditions shown as MIN or MAX, use the appropriate value specified under recommended operating conditions.

‡ All typical values are at V_{CC} = 5 V, T_A = 25°C.

§ Not more than one output should be shorted at a time.

switching characteristics, V_{CC} = 5 V, T_A = 25°C

PARAMETER	FROM (INPUT)	TO (OUTPUT)	TEST CONDITIONS	MIN	TYP	MAX	UNIT
t _{PLH}	Any	Y	R _L = 400 Ω, C _L = 15 pF	18		27	ns
t _{PHL}				15		22	ns

3

TTL DEVICES

TYPES SN54LS13, SN74LS13
DUAL 4-INPUT
POSITIVE-NAND SCHMITT TRIGGERS

recommended operating conditions

	SN54LS13			SN74LS13			UNIT
	MIN	NOM	MAX	MIN	NOM	MAX	
V _{CC} Supply voltage	4.5	5	5.5	4.75	5	5.25	V
I _{OH} High-level output current			-0.4			-0.4	mA
I _{OL} Low-level output current			4			8	mA
T _A Operating free-air temperature	-55		125	0		70	°C

electrical characteristics over recommended operating free-air temperature range (unless otherwise noted)

PARAMETER	TEST CONDITIONS [†]	SN54LS13			SN74LS13			UNIT
		MIN	TYP [‡]	MAX	MIN	TYP [‡]	MAX	
V _{T+}	V _{CC} = 5 V	1.4	1.6	1.9	1.4	1.6	1.9	V
V _{T-}	V _{CC} = 5 V	0.5	0.8	1	0.5	0.8	1	V
Hysteresis (V _{T+} - V _{T-})	V _{CC} = 5 V	0.4	0.8		0.4	0.8		V
V _{IK}	V _{CC} = MIN, I _I = -18 mA			-1.5			-1.5	V
V _{OH}	V _{CC} = MIN, V _I = 0.5 V, I _{OH} = -0.4 mA	2.5	3.4		2.7	3.4		V
V _{OL}	V _{CC} = MIN, V _I = 1.9 V	I _{OL} = 4 mA		0.25	0.4	0.25		0.4
		I _{OL} = 8 mA				0.35	0.5	
I _{T+}	V _{CC} = 5 V, V _I = V _{T+}	-0.14			-0.14			mA
I _{T-}	V _{CC} = 5 V, V _I = V _{T-}	-0.18			-0.18			mA
I _I	V _{CC} = MAX, V _I = 7 V	0.1			0.1			mA
I _{IH}	V _{CC} = MAX, V _{IH} = 2.7 V	20			20			μA
I _{IL}	V _{CC} = MAX, V _{IL} = 0.4 V	-0.4			-0.4			mA
I _{OS} §	V _{CC} = MAX	-20		-100	-20		-100	mA
I _{CCH}	V _{CC} = MAX	2.9		6	2.9		6	mA
I _{CCL}	V _{CC} = MAX	4.1		7	4.1		7	mA

[†] For conditions shown as MIN or MAX, use the appropriate value specified under recommended operating conditions.

[‡] All typical values are at V_{CC} = 5 V, T_A = 25°C.

§ Not more than one output should be shorted at a time, and duration of the short-circuit should not exceed one second.

switching characteristics, V_{CC} = 5 V, T_A = 25°C

PARAMETER	FROM (INPUT)	TO (OUTPUT)	TEST CONDITIONS	MIN	TYP	MAX	UNIT
¹ PLH	Any	Y	R _L = 2 kΩ, C _L = 15 pF			15	22
¹ PHL						18	27

3 TTL DEVICES

TYPES SN5413, SN54LS13, SN7413, SN74LS13

DUAL 4-INPUT POSITIVE-NAND SCHMITT TRIGGERS

PARAMETER MEASUREMENT INFORMATION

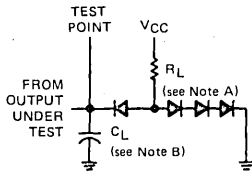

LOAD CIRCUIT

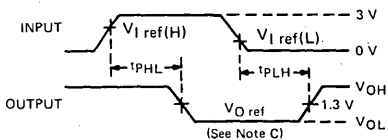

VOLTAGE WAVEFORMS

- NOTES: A. All diodes are 1N3064 or equivalent.
 B. C_L includes probe and jig capacitance.
 C. Generator characteristics and reference voltages are:

	Generator Characteristics				Reference Voltages		
	Z_{out}	PRR	t_r	t_f	$V_{I\ ref(H)}$	$V_{I\ ref(L)}$	$V_{O\ ref}$
SN54'/SN74'	50 Ω	1 MHz	10 ns	10 ns	1.7 V	0.9 V	1.5 V
SN54LS'/SN74LS'	50 Ω	1 MHz	15 ns	6 ns	1.6 V	0.8 V	1.3 V

TYPICAL CHARACTERISTICS OF '13 CIRCUITS

POSITIVE-GOING THRESHOLD VOLTAGE

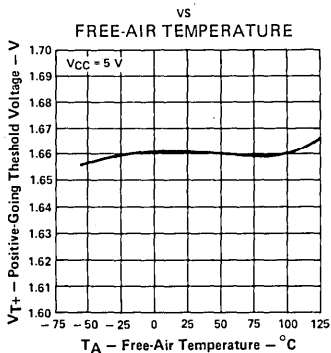

FIGURE 1

NEGATIVE-GOING THRESHOLD VOLTAGE

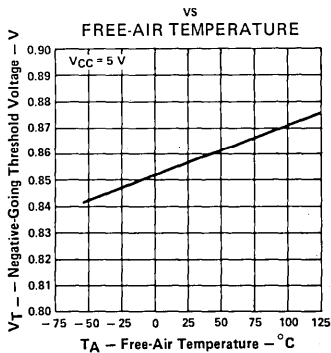

FIGURE 2

HYSTERESIS

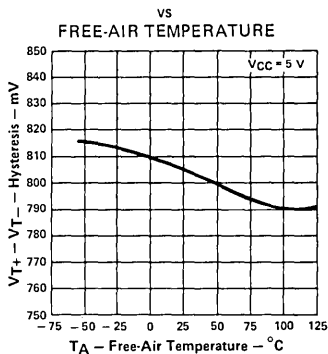

FIGURE 3

Data for temperatures below 0°C and 70°C and supply voltages below 4.75 V and above 5.25 V are applicable for SN5413 only.

TYPES SN5413, SN7413
DUAL 4-INPUT
POSITIVE-NAND SCHMITT TRIGGERS

TYPICAL CHARACTERISTICS OF '13 CIRCUITS

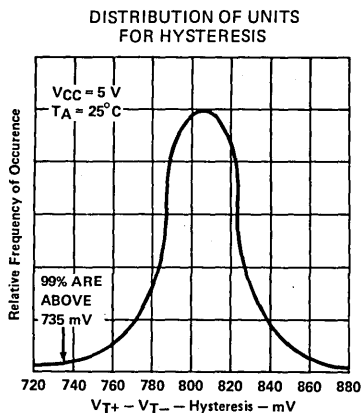

FIGURE 4

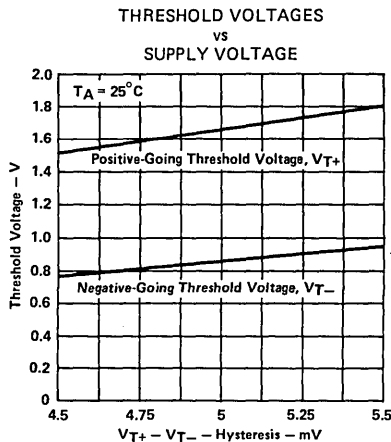

FIGURE 5

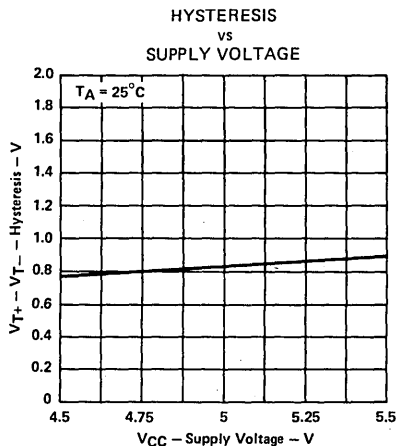

FIGURE 6

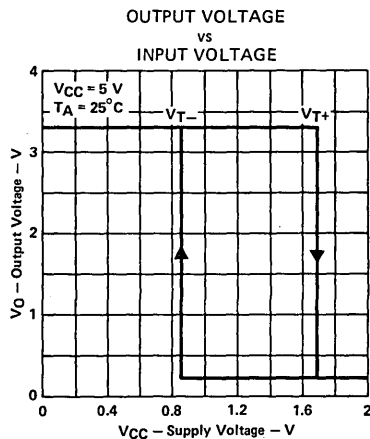

FIGURE 7

Data for temperatures below 0°C and 70°C and supply voltages below 4.75 V and above 5.25 V are applicable for SN5413 only.

TYPES SN54LS13, SN74LS13
 DUAL 4-INPUT
 POSITIVE-NAND SCHMITT TRIGGERS

TYPICAL CHARACTERISTICS OF 'LS13 CIRCUITS

POSITIVE-GOING THRESHOLD VOLTAGE
 vs
 FREE-AIR TEMPERATURE

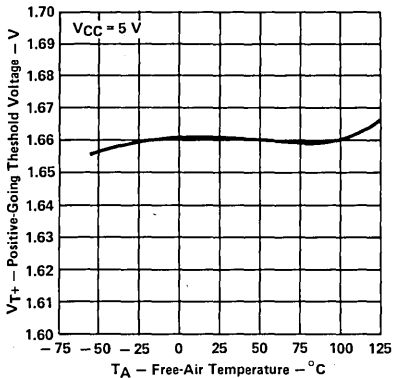

FIGURE 8

NEGATIVE-GOING THRESHOLD VOLTAGE
 vs
 FREE-AIR TEMPERATURE

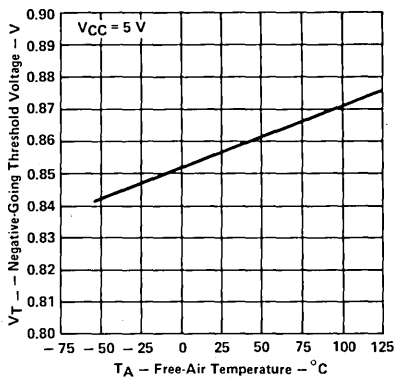

FIGURE 9

HYSTERESIS
 vs
 FREE-AIR TEMPERATURE

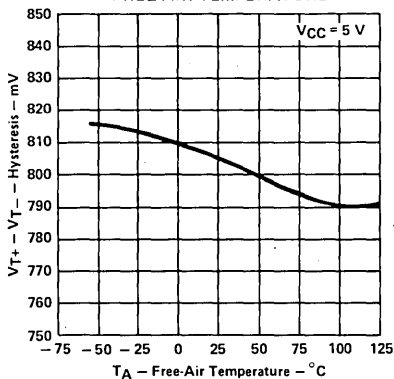

FIGURE 10

DISTRIBUTION OF UNITS
 FOR HYSTERESIS

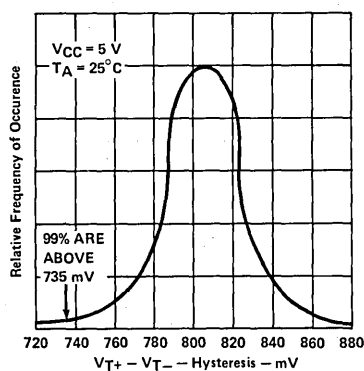

FIGURE 11

Data for temperatures below 0°C and above 70°C and supply voltages below 4.75 V and above 5.25 V are applicable for SN54LS13 only.



TTL DEVICES

TYPES SN54LS13, SN74LS13
DUAL 4-INPUT
POSITIVE-NAND SCHMITT TRIGGERS

TYPICAL CHARACTERISTICS OF 'LS13 CIRCUITS

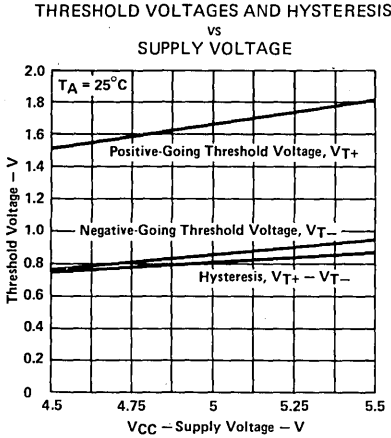

FIGURE 12

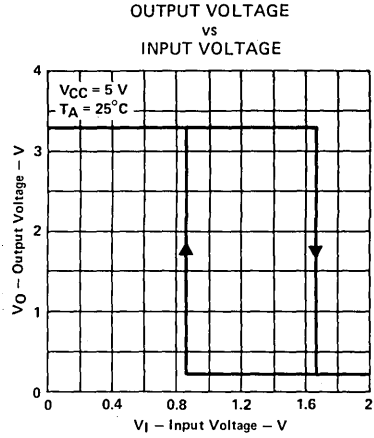

FIGURE 13

3

TTL DEVICES

Data for temperatures below 0°C and above 70°C and supply voltages below 4.75 V and above 5.25 V are applicable for SN54LS13 only.

TYPES SN5413, SN54LS13, SN7413, SN74LS13
 DUAL 4-INPUT
 POSITIVE-NAND SCHMITT TRIGGERS

TYPICAL APPLICATION DATA

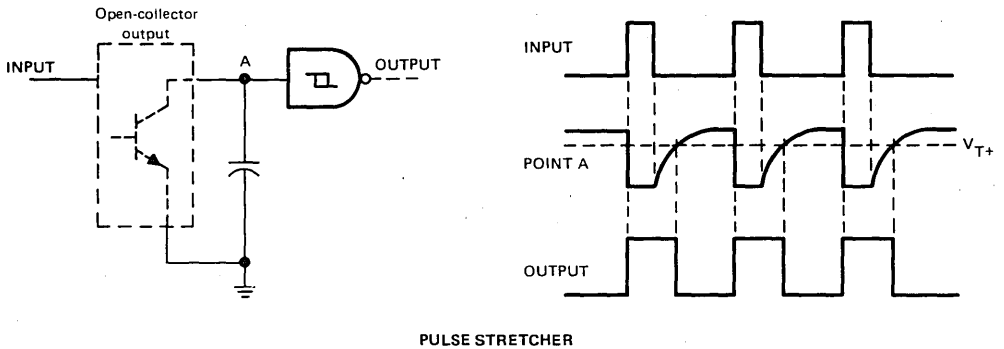
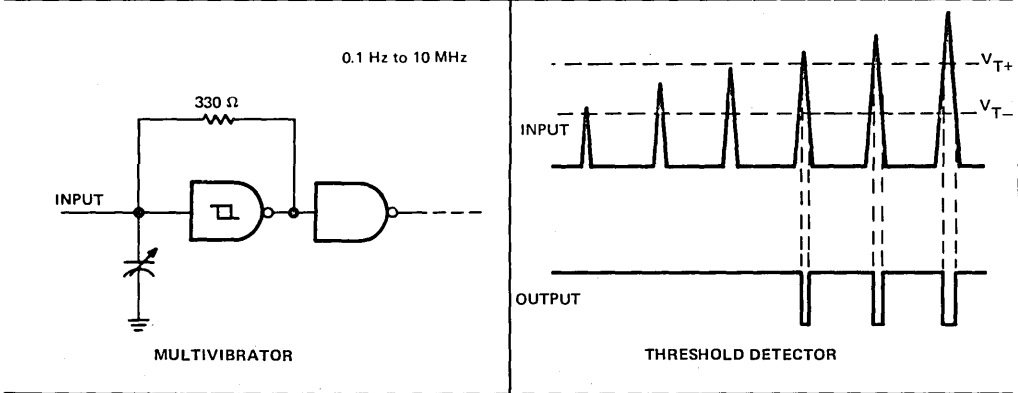
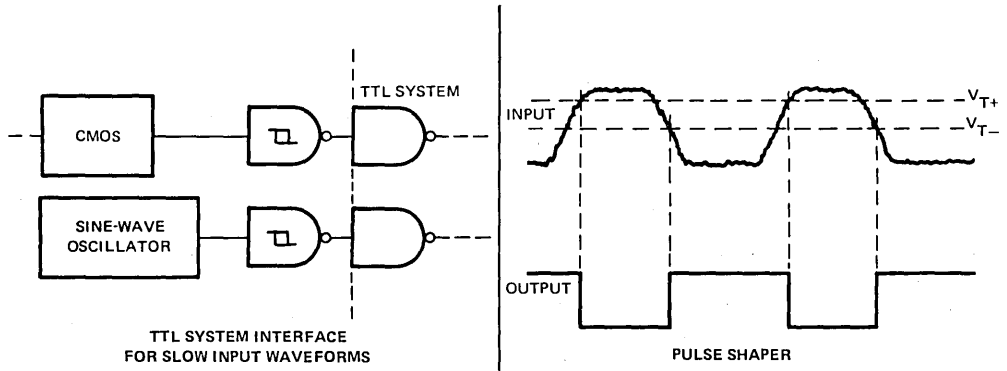

3
 TTL DEVICES

TYPES SN5414, SN54LS14, SN7414, SN74LS14 HEX SCHMITT-TRIGGER INVERTERS

REVISED DECEMBER 1983

- Operation from Very Slow Edges
- Improved Line-Receiving Characteristics
- High Noise Immunity

description

Each circuit functions as an inverter, but because of the Schmitt action, it has different input threshold levels for positive (V_{T+}) and for negative going (V_{T-}) signals.

These circuits are temperature-compensated and can be triggered from the slowest of input ramps and still give clean, jitter-free output signals.

The SN5414 and SN54LS14 are characterized for operation over the full military temperature range of -55°C to 125°C . The SN7414 and the SN74LS14 are characterized for operation from 0°C to 70°C .

logic diagram

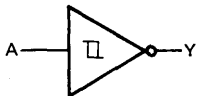

positive logic

$$Y = \bar{A}$$

SN5414, SN54LS14 ... J OR W PACKAGE
SN7414 ... J OR N PACKAGE
SN74LS14 ... D, J OR N PACKAGE
(TOP VIEW)

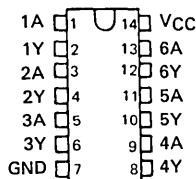

SN54LS14 ... FK PACKAGE
SN74LS14 ... FN PACKAGE
(TOP VIEW)

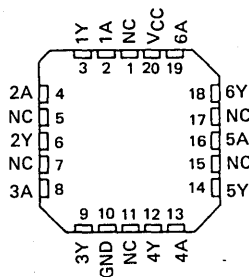

NC - No internal connection

3

TTL DEVICES

TYPES SN5414, SN54LS14, SN7414, SN74LS14 HEX SCHMITT-TRIGGER INVERTERS

schematics

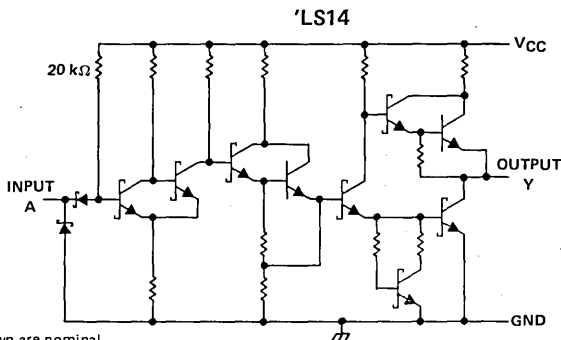
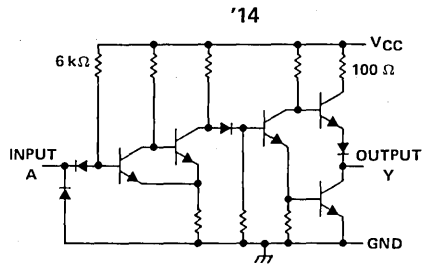

Resistor values shown are nominal.

absolute maximum ratings over operating free-air temperature range (unless otherwise noted)

Supply voltage, V_{CC} (see Note 1)	7 V
Input voltage: '14	5.5 V
'LS14	7 V
Operating free-air temperature: SN54'	-55°C to 125°C
SN74'	0°C to 70°C
Storage temperature range	-65°C to 150°C

NOTE 1: Voltage values are with respect to network ground terminal.

3 TTL DEVICES

TYPES SN5414, SN7414
HEX SCHMITT-TRIGGER INVERTERS

recommended operating conditions

	SN5414			SN7414			UNIT
	MIN	NOM	MAX	MIN	NOM	MAX	
V _{CC} Supply voltage	4.5	5	5.5	4.75	5	5.25	V
I _{OH} High-level output current			-0.8			-0.8	mA
I _{OL} Low-level output current			16			16	mA
T _A Operating free-air temperature	-55		125	0		70	°C

electrical characteristics over recommended operating free-air temperature range (unless otherwise noted)

PARAMETER	TEST CONDITIONS†	MIN	TYP‡	MAX	UNIT
V _{T+}	V _{CC} = 5 V	1.5	1.7	2	V
V _{T-}	V _{CC} = 5 V	0.6	0.9	1.1	V
Hysteresis (V _{T+} - V _{T-})	V _{CC} = 5 V	0.4	0.8		V
V _{IK}	V _{CC} = MIN, I _I = -12 mA			-1.5	V
V _{OH}	V _{CC} = MIN, V _I = 0.6 V, I _{OH} = -0.8 mA	2.4	3.4		V
V _{OL}	V _{CC} = MIN, V _I = 2 V, I _{OL} = 16 mA		0.2	0.4	V
I _{T+}	V _{CC} = 5 V, V _I = V _{T+}		-0.43		mA
I _{T-}	V _{CC} = 5 V, V _I = V _{T-}		-0.56		mA
I _I	V _{CC} = MAX, V _I = 5.5 V			1	mA
I _{IH}	V _{CC} = MAX, V _{IH} = 2.4 V			40	μA
I _{IL}	V _{CC} = MAX, V _{IL} = 0.4 V		-0.8	-1.2	mA
I _{OS} §	V _{CC} = MAX	-18		-55	mA
I _{CCH}	V _{CC} = MAX		22	36	mA
I _{CCL}	V _{CC} = MAX		39	60	mA

† For conditions shown as MIN or MAX, use the appropriate value specified under recommended operating conditions.

‡ All typical values are at V_{CC} = 5 V, T_A = 25° C.

§ Not more than one output should be shorted at a time.

switching characteristics, V_{CC} = 5 V, T_A = 25° C

PARAMETER	FROM (INPUT)	TO (OUTPUT)	TEST CONDITIONS	MIN	TYP	MAX	UNIT
t _{PLH}	A	Y	R _L = 400 Ω, C _L = 15 pF		15	22	ns
t _{PHL}					15	22	ns



TTL DEVICES

TYPES SN54LS14, SN74LS14 HEX SCHMITT-TRIGGER INVERTERS

recommended operating conditions

	SN54LS14			SN74LS14			UNIT
	MIN	NOM	MAX	MIN	NOM	MAX	
V _{CC} Supply voltage	4.5	5	5.5	4.75	5	5.25	V
I _{OH} High-level output current	-0.4			-0.4			mA
I _{OL} Low-level output current	4			8			mA
T _A Operating free-air temperature	-55			125			°C

electrical characteristics over recommended operating free-air temperature range (unless otherwise noted)

PARAMETER	TEST CONDITIONS†	SN54LS14			SN74LS14			UNIT	
		MIN	TYP‡	MAX	MIN	TYP‡	MAX		
V _{T+}	V _{CC} = 5 V	1.4	1.6	1.9	1.4	1.6	1.9	V	
V _{T-}	V _{CC} = 5 V	0.5	0.8	1	0.5	0.8	1	V	
Hysteresis (V _{T+} - V _{T-})	V _{CC} = 5 V	0.4			0.4			V	
V _{IK}	V _{CC} = MIN, I _I = -18 mA	-1.5			-1.5			V	
V _{OH}	V _{CC} = MIN, V _I = 0.5 V, I _{OH} = -0.4 mA	2.5	3.4		2.7	3.4		V	
V _{OL}	V _{CC} = MIN, V _I = 1.9 V	I _{OL} = 4 mA		0.25	0.4	0.25		0.4	V
		I _{OL} = 8 mA				0.35		0.5	
I _{T+}	V _{CC} = 5 V, V _I = V _{T+}	-0.14			-0.14			mA	
I _{T-}	V _{CC} = 5 V, V _I = V _{T-}	-0.18			-0.18			mA	
I _I	V _{CC} = MAX, V _I = 7 V	0.1			0.1			mA	
I _{IH}	V _{CC} = MAX, V _{IH} = 2.7 V	20			20			µA	
I _{IL}	V _{CC} = MAX, V _{IL} = 0.4 V	-0.4			-0.4			mA	
I _{OS} §	V _{CC} = MAX	-20	-100		-20	-100		mA	
I _{CCH}	V _{CC} = MAX	8.6			8.6			16	mA
I _{CCL}	V _{CC} = MAX	12			12			21	mA

† For conditions shown as MIN or MAX, use the appropriate value specified under recommended operating conditions.

‡ All typical values are at V_{CC} = 5 V, T_A = 25°C.

§ Not more than one output should be shorted at a time, and duration of the short-circuit should not exceed one second.

switching characteristics, V_{CC} = 5 V, T_A = 25°C

PARAMETER	FROM (INPUT)	TO (OUTPUT)	TEST CONDITIONS	MIN	TYP	MAX	UNIT
t _{PLH}	A	Y	R _L = 2 kΩ, C _L = 15 pF	15	22		ns
t _{PHL}				15	22		ns

TYPES SN5414, SN54LS14, SN7414, SN74LS14 HEX SCHMITT-TRIGGER INVERTERS

PARAMETER MEASUREMENT INFORMATION

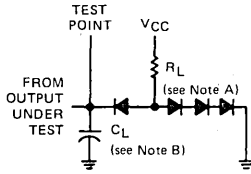

LOAD CIRCUIT

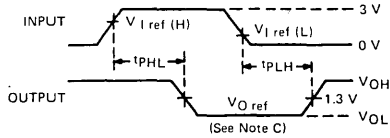

VOLTAGE WAVEFORMS

- NOTES: A. All diodes are 1N3064 or equivalent.
B. C_L includes probe and jig capacitance.
C. Generator characteristics and reference voltage are:

	Generator Characteristics				Reference Voltages		
	Z_{out}	PRR	t_r	t_f	$V_{I\ ref(H)}$	$V_{I\ ref(L)}$	$V_{O\ ref}$
SN54'/SN74'	50 Ω	1 MHz	10 ns	10 ns	1.7 V	0.9 V	1.5 V
SN54LS'/SN74LS'	50 Ω	1 MHz	15 ns	6 ns	1.6 V	0.8 V	1.3 V

TYPICAL CHARACTERISTICS OF '14 CIRCUITS

POSITIVE-GOING THRESHOLD VOLTAGE

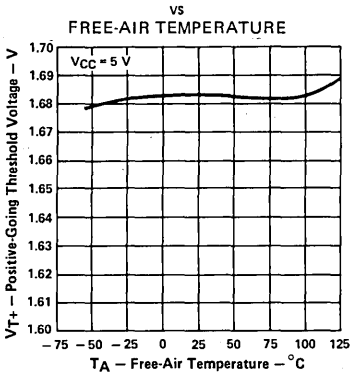

FIGURE 1

NEGATIVE-GOING THRESHOLD VOLTAGE

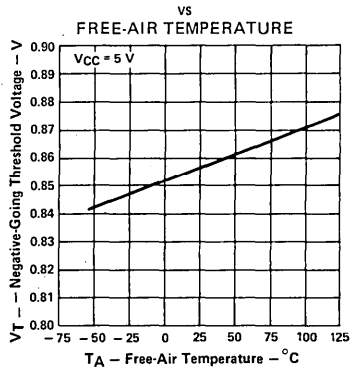

FIGURE 2

HYSTERESIS

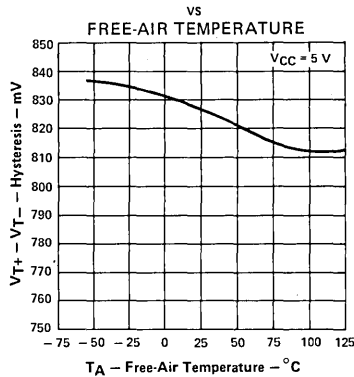
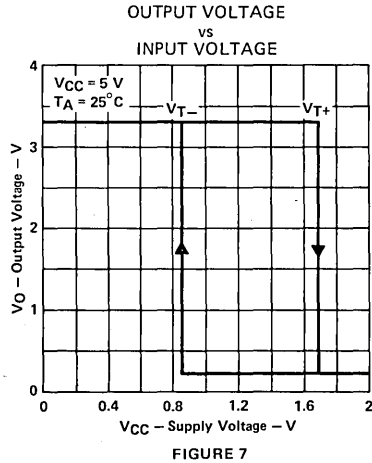
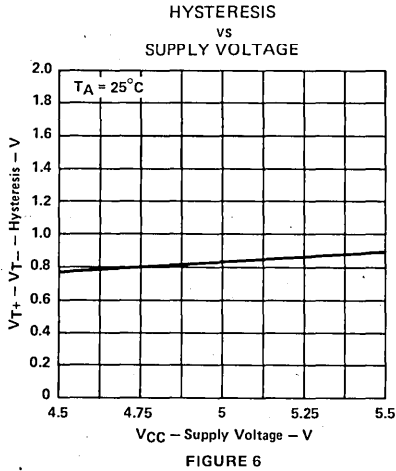
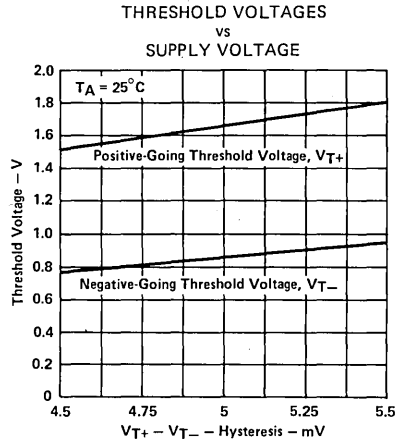
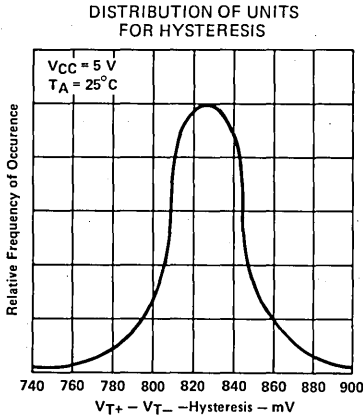

FIGURE 3

Data for temperatures below 0°C and 70°C and supply voltages below 4.75V and above 5.25 V are applicable for SN5414 only.

TYPES SN5414, SN7414
HEX SCHMITT-TRIGGER INVERTERS

TYPICAL CHARACTERISTICS OF '14 CIRCUITS



Data for temperatures below 0°C and 70°C and supply voltages below 4.75 V and above 5.25 V are applicable for SN5414 only.

3 TTL DEVICES

TYPICAL CHARACTERISTICS OF 'LS14 CIRCUITS

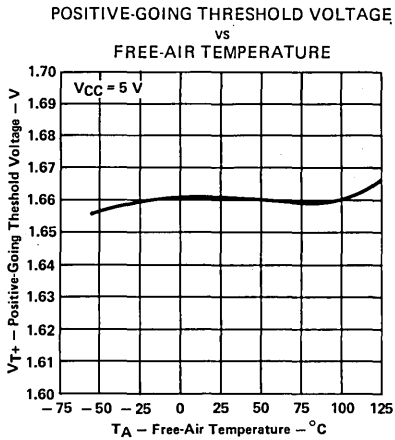

FIGURE 8

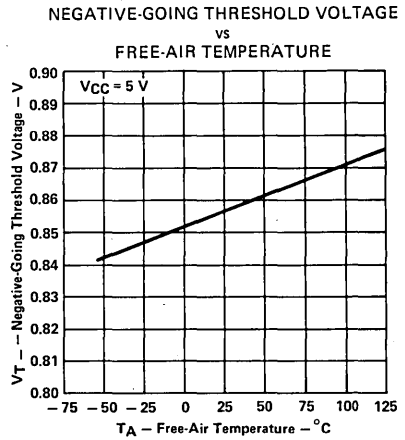

FIGURE 9

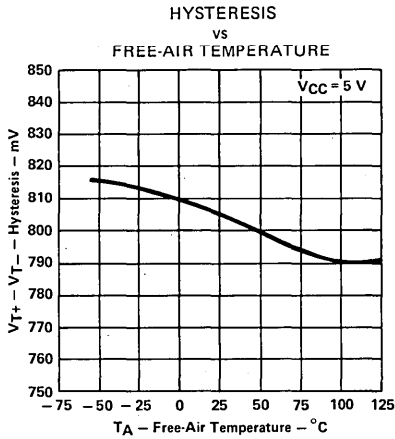

FIGURE 10

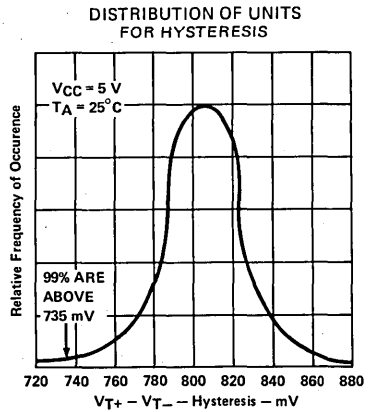

FIGURE 11

Data for temperatures below 0°C and above 70°C and supply voltages below 4.75 V and above 5.25 V are applicable for SN54LS14 only.

TYPICAL CHARACTERISTICS OF 'LS14 CIRCUITS

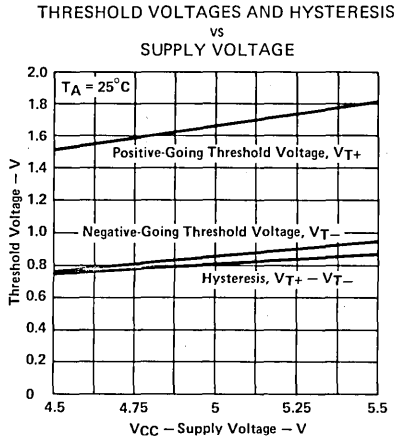

FIGURE 12

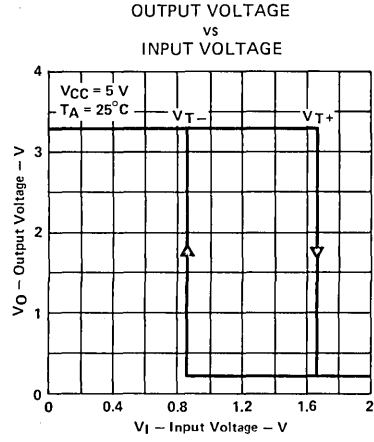

FIGURE 13

Data for temperatures below 0°C and above 70°C and supply voltages below 4.75 V and above 5.25 V are applicable for SN54LS14 only.



TTL DEVICES

TYPICAL APPLICATION DATA

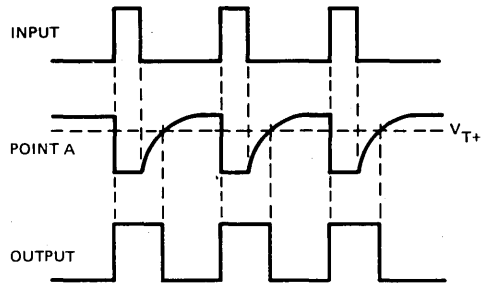
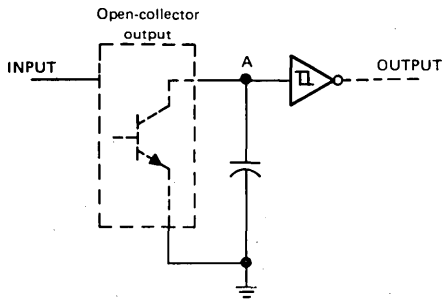
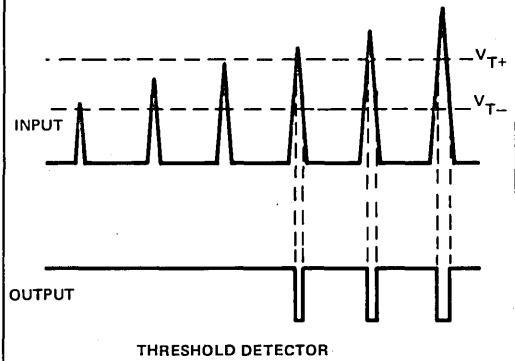
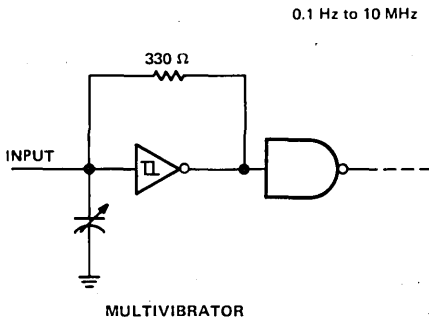
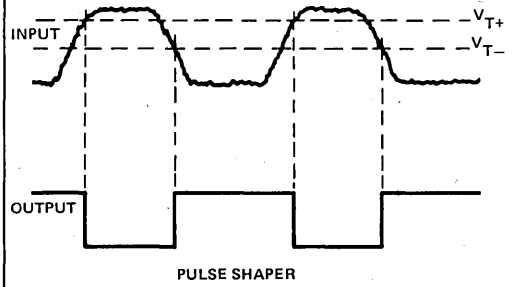
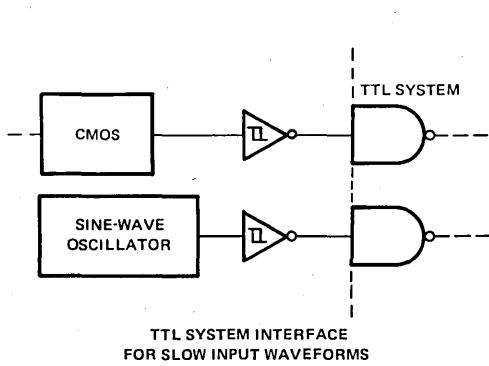

PULSE STRETCHER

3
TTL DEVICES

3

TTL DEVICES

TYPES SN54H15, SN54LS15, SN54S15, SN74H15, SN74LS15, SN74S15 TRIPLE 3-INPUT POSITIVE-AND GATES WITH OPEN-COLLECTOR OUTPUTS

REVISED APRIL 1985

- Package Options Include Both Plastic and Ceramic Chip Carriers in Addition to Plastic and Ceramic DIPs
- Dependable Texas Instruments Quality and Reliability

description

These devices contain three independent 3-input AND gates with open-collector outputs. The open-collector outputs require pull-up resistors to perform correctly. They may be connected to other open-collector outputs to implement active-low wired-OR or active-high wired-AND functions. Open-collector devices are often used to generate high V_{OH} levels.

The SN54H15, SN54LS15, and SN54S15 are characterized for operation over the full military temperature range of -55°C to 125°C . The SN74H15, SN74LS15, and SN74S15 are characterized for operation from 0°C to 70°C .

FUNCTION TABLE (each gate)

INPUTS			OUTPUT
A	B	C	Y
H	H	H	H
L	X	X	L
X	L	X	L
X	X	L	L

logic diagram (each gate)



positive logic

$$Y = A \cdot B \cdot C \text{ or } Y = \overline{\overline{A} + \overline{B} + \overline{C}}$$

SN54H15, SN54LS15, SN54S15 ... J OR W PACKAGE
SN74H15 ... J OR N PACKAGE
SN74LS15, SN74S15 ... D, J OR N PACKAGE

(TOP VIEW)

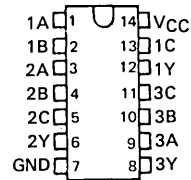

SN54LS15, SN54S15 ... FK PACKAGE
SN74LS15, SN74S15 ... FN PACKAGE

(TOP VIEW)

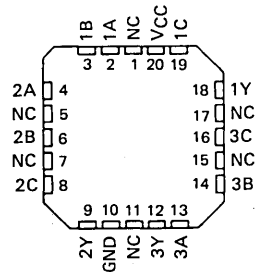

NC - No internal connection

3

TTL DEVICES

**TYPES SN54H15, SN54LS15, SN54S15,
SN74H15, SN74LS15, SN74S15
TRIPLE 3-INPUT POSITIVE-AND GATES WITH OPEN-COLLECTOR OUTPUTS**

schematics (each gate)

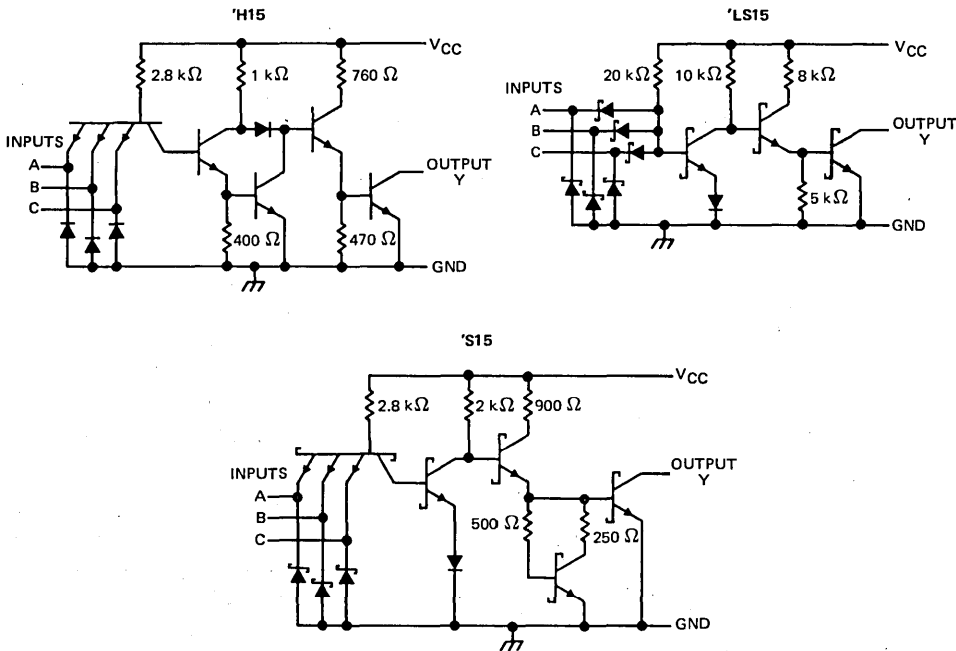

Resistor values shown are nominal.

absolute maximum ratings over operating free-air temperature range (unless otherwise noted)

Supply voltage, V_{CC} (see Note 1)	7 V
Input voltage: 'H15, 'S15	5.5 V
'LS15	7 V
Off-state output voltage	7 V
Operating free-air temperature range: SN54'	-55°C to 125°C
SN74'	0°C to 70°C
Storage temperature range	-65°C to 150°C

NOTE 1: Voltage values are with respect to network ground terminal.

3 TTL DEVICES

TYPES SN54H15, SN74H15

TRIPLE 3-INPUT POSITIVE-AND GATES WITH OPEN-COLLECTOR OUTPUTS

recommended operating conditions

	SN54H15			SN74H15			UNIT
	MIN	NOM	MAX	MIN	NOM	MAX	
V _{CC} Supply voltage	4.5	5	5.5	4.75	5	5.25	V
V _{IH} High-level input voltage	2			2			V
V _{IL} Low-level input voltage	0.8			0.8			V
V _{OH} High-level output voltage	5.5			5.5			V
I _{OL} Low-level output current	20			20			mA
T _A Operating free-air temperature	-55 125			0 70			°C

electrical characteristics over recommended operating free-air temperature range (unless otherwise noted)

PARAMETER	TEST CONDITIONS†	SN54H15		SN74H15		UNIT
		MIN	TYP‡	MAX	MIN	
V _{IK}	V _{CC} = MIN, I _I = -8 mA	-1.5		-1.5		V
I _{OH}	V _{CC} = MIN, V _{IH} = 2 V, V _{OH} = 5.5 V	0.25		0.25		mA
V _{OL}	V _{CC} = MIN, V _{IH} = 2 V, I _{OL} = 20 mA	0.2	0.4	0.2	0.4	V
I _I	V _{CC} = MAX, V _I = 5.5 V	0.1		0.1		mA
I _{IH}	V _{CC} = MAX, V _I = 2.4 V	50		50		μA
I _{IL}	V _{CC} = MAX, V _I = 0.4 V	-2		-2		mA
I _{CCH}	V _{CC} = MAX, V _I = 4.5 V	15	25	15	25	mA
I _{CCL}	V _{CC} = MAX, V _I = 0 V	30	48	30	48	mA

† For conditions shown as MIN or MAX, use the appropriate value specified under recommended operating conditions.

‡ All typical values are at V_{CC} = 5 V, T_A = 25°C.

switching characteristics, V_{CC} = 5 V, T_A = 25°C (see note 2)

PARAMETER	FROM (INPUT)	TO (OUTPUT)	TEST CONDITIONS		MIN	TYP	MAX	UNIT
t _{PLH}	A, B, or C	Y	R _L = 280 Ω,	C _L = 25 pF	12	18	ns	
t _{PHL}					9	13	ns	

NOTE 2: See General Information Section for load circuits and voltage waveforms.

3
TTL DEVICES

TYPES SN54LS15, SN74LS15

TRIPLE 3-INPUT POSITIVE-AND GATES WITH OPEN-COLLECTOR OUTPUTS

recommended operating conditions

	SN54LS15			SN74LS15			UNIT
	MIN	NOM	MAX	MIN	NOM	MAX	
V _{CC} Supply voltage	4.5	5	5.5	4.75	5	5.25	V
V _{IH} High-level input voltage	2			2			V
V _{IL} Low-level input voltage			0.7			0.8	V
V _{OH} High-level output voltage			5.5			5.5	V
I _{OL} Low-level output current			4			8	mA
T _A Operating free-air temperature	-55		125	0		70	°C

electrical characteristics over recommended operating free-air temperature range (unless otherwise noted)

PARAMETER	TEST CONDITIONS†	SN54LS15		SN74LS15		UNIT		
		MIN	TYP‡	MAX	MIN		TYP‡	MAX
V _{IK}	V _{CC} = MIN, I _I = -18 mA			-1.5		-1.5	V	
I _{OH}	V _{CC} = MIN, V _{IH} = 2 V, V _{OH} = 5.5 V			0.1		0.1	mA	
V _{OL}	V _{CC} = MIN, V _{IH} = 2 V, I _{OL} = 4 mA		0.25	0.4		0.25	0.4	V
	V _{CC} = MIN, V _{IH} = 2 V, I _{OL} = 8 mA					0.35	0.5	
I _I	V _{CC} = MAX, V _I = 7 V			0.1		0.1	mA	
I _{IH}	V _{CC} = MAX, V _I = 2.7 V			20		20	μA	
I _{IL}	V _{CC} = MAX, V _I = 0.4 V			-0.4		-0.4	mA	
I _{CCH}	V _{CC} = MAX, V _I = 4.5 V		1.8	3.6		1.8	3.6	mA
I _{CCL}	V _{CC} = MAX, V _I = 0 V		3.3	6.6		3.3	6.6	mA

† For conditions shown as MIN or MAX, use the appropriate value specified under recommended operating conditions.

‡ All typical values are at V_{CC} = 5 V, T_A = 25°C.

switching characteristics, V_{CC} = 5 V, T_A = 25°C (see note 2)

PARAMETER	FROM (INPUT)	TO (OUTPUT)	TEST CONDITIONS		MIN	TYP	MAX	UNIT
t _{PLH}	A, B, or C	Y	R _L = 2 kΩ,	C _L = 15 pF		20	35	ns
t _{PHL}						17	35	ns

NOTE 2: See General Information Section for load circuits and voltage waveforms.

TYPES SN54S15, SN74S15
TRIPLE 3-INPUT POSITIVE-AND GATES WITH OPEN-COLLECTOR OUTPUTS

recommended operating conditions

	SN54S15			SN74S15			UNIT
	MIN	NOM	MAX	MIN	NOM	MAX	
V _{CC} Supply voltage	4.5	5	5.5	4.75	5	5.25	V
V _{IH} High-level input voltage	2			2			V
V _{IL} Low-level input voltage	0.8			0.8			V
V _{OH} High-level output voltage	5.5			5.5			V
I _{OL} Low-level output current	20			20			mA
T _A Operating free-air temperature	-55	125		0	70		°C

electrical characteristics over recommended operating free-air temperature range (unless otherwise noted)

PARAMETER	TEST CONDITIONS†	MIN	TYP‡	MAX	UNIT
V _{IK}	V _{CC} = MIN, I _I = -12 mA			-1.2	V
I _{OH}	V _{CC} = MIN, V _{IH} = 2 V, V _{OH} = 5.5 V			0.25	mA
V _{OL}	V _{CC} = MIN, V _{IH} = 2 V, I _{OL} = 16 mA			0.5	V
I _I	V _{CC} = MAX, V _I = 5.5 V			1	mA
I _{IH}	V _{CC} = MAX, V _I = 2.7 V			50	μA
I _{IL}	V _{CC} = MAX, V _I = 0.5 V			-2	mA
I _{CCH}	V _{CC} = MAX, V _I = 4.5 V		10.5	19.5	mA
I _{CCL}	V _{CC} = MAX, V _I = 0 V		24	42	mA

† For conditions shown as MIN or MAX, use the appropriate value specified under recommended operating conditions.

‡ All typical values are at V_{CC} = 5 V, T_A = 25°C.

switching characteristics, V_{CC} = 5 V, T_A = 25°C (see note 2)

PARAMETER	FROM (INPUT)	TO (OUTPUT)	TEST CONDITIONS	MIN	TYP	MAX	UNIT
t _{PLH}	A, B, or C	Y	R _L = 280 Ω, C _L = 15 pF	5.5	8.5		ns
t _{PHL}				6	9		ns
t _{PLH}			R _L = 280 Ω, C _L = 50 pF	8.5			ns
t _{PHL}				8			ns

NOTE 2: See General Information Section for load circuits and voltage waveforms.

3
TTL DEVICES

TYPES SN74LS18, SN74LS19, SN74LS24 SCHMITT-TRIGGER POSITIVE-NAND GATES AND INVERTERS WITH TOTEM-POLE OUTPUTS

JANUARY 1981—REVISED DECEMBER 1983

- Functionally and Mechanically Identical To 'LS13, 'LS14, and 'LS132, Respectively
- Improved Line-Receiving Characteristics
- P-N-P Inputs Reduce System Loading
- Excellent Noise Immunity With Typical Hysteresis of 0.7 V

description

Each circuit functions as a NAND gate or inverter, but because of the Schmitt action, it has different input threshold levels for positive (V_{T+}) and for negative (V_{T-}) signals. The hysteresis or backlash, which is the difference between the two threshold levels ($V_{T+} - V_{T-}$), is typically 900 millivolts.

These circuits are temperature-compensated and can be triggered from the slowest of input ramps and still give clean, jitter-free output signals.

logic diagram (each gate or inverter)

'LS18

'LS19

'LS24

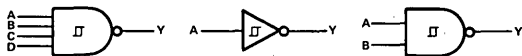

SN74LS19 ... D, J OR N PACKAGE

(TOP VIEW)

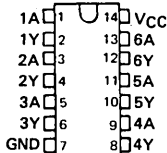

SN74LS24 ... D, J OR N PACKAGE

(TOP VIEW)

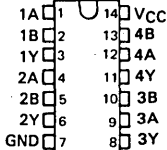

SN74LS18 ... D, J OR N PACKAGE

(TOP VIEW)

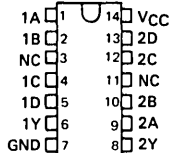

SN74LS18 ... FN PACKAGE

(TOP VIEW)

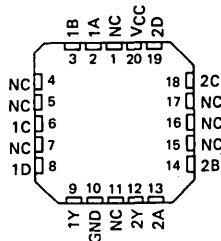

SN74LS19 ... FN PACKAGE

(TOP VIEW)

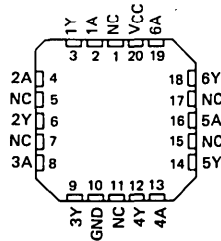

SN74LS24 ... FN PACKAGE

(TOP VIEW)

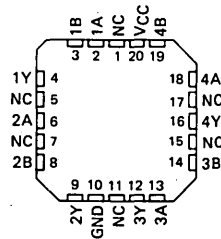

NC - No internal connection

3 TTL DEVICES

PRODUCTION DATA

This document contains information current as of publication date. Products conform to specifications per the terms of Texas Instruments standard warranty. Production processing does not necessarily include testing of all parameters.



POST OFFICE BOX 225012 • DALLAS, TEXAS 75265

TYPES SN74LS18, SN74LS19, SN74LS24 SCHMITT-TRIGGER POSITIVE-NAND GATES AND INVERTERS WITH TOTEM-POLE OUTPUTS

schematic (each gate)

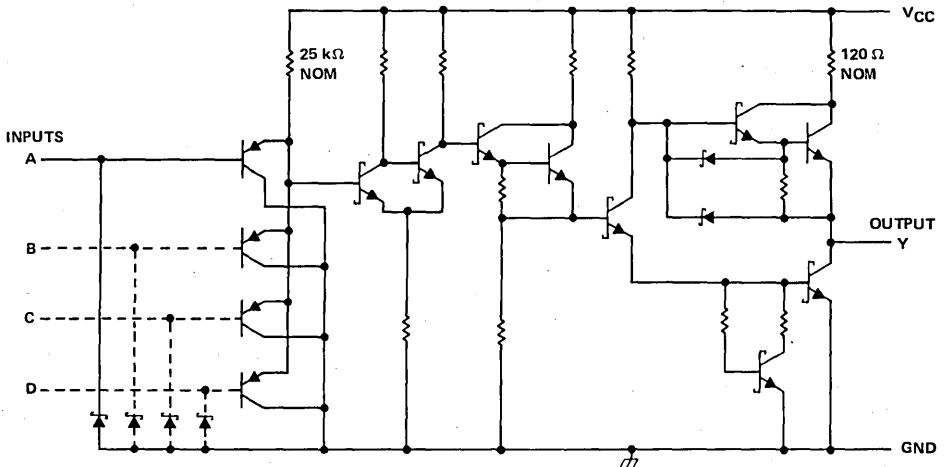

absolute maximum ratings over operating free-air temperature range (unless otherwise noted)

Supply voltage, V_{CC} (see Note 1)	7 V
Input voltage	7 V
Operating free-air temperature range: SN74LS'	0°C to 70°C
Storage temperature range	-65°C to 150°C

recommended operating conditions

	SN74LS'			UNIT
	MIN	NOM	MAX	
Supply voltage, V_{CC}	4.75	5	5.25	V
High-level output current, I_{OH}			-400	μ A
Low-level output current, I_{OL}			8	mA
Operating free-air temperature, T_A	0		70	°C

3

TTL DEVICES

TYPES SN74LS18, SN74LS19, SN74LS24 SCHMITT-TRIGGER POSITIVE-NAND GATES AND INVERTERS WITH TOTEM-POLE OUTPUTS

electrical characteristics over recommended operating free-air temperature range (unless otherwise noted)

PARAMETER	TEST CONDITIONS†			SN74LS*			UNIT
				MIN	TYP‡	MAX	
V_{T+}	$V_{CC} = 5V$			1.65	1.9	2.15	V
V_{T-}	$V_{CC} = 5V$			0.75	1.0	1.25	V
Hysteresis ($V_{T+} - V_{T-}$)	$V_{CC} = 5V$			0.4	0.9		V
V_{IK}	$V_{CC} = \text{MIN}, I_I = -18 \text{ mA}$					-1.5	V
V_{OH}	$V_{CC} = \text{MIN}, V_I = V_{T-} \text{ min}, I_{OH} = -0.4 \text{ mA}$			2.7	3.4		V
V_{OL}	$V_{CC} = \text{MIN}, V_I = V_{T+} \text{ max}$			$I_{OL} = 4 \text{ mA}$	0.25	0.4	V
				$I_{OL} = 8 \text{ mA}$	0.35	0.5	
t_{T+}	$V_{CC} = 5V, V_I = V_{T+}$			-2	-2	20	μA
t_{T-}	$V_{CC} = 5V, V_I = V_{T-}$			-5	-30		μA
I_I	$V_{CC} = \text{MAX}, V_I = 7V$					0.1	mA
I_{IH}	$V_{CC} = \text{MAX}, V_I = 2.7V$					20	μA
I_{IL}	$V_{CC} = \text{MAX}, V_I = 0.4V$					-50	μA
$I_{OS}§$	$V_{CC} = \text{MAX}, V_I = V_O = 0V$			-20		-100	mA
I_{CCH}	$V_{CC} = \text{MAX}, V_I = 0V$			'LS18	3.3	6	mA
				'LS19	9.9	18	
				'LS24	6.6	12	
I_{CCL}	$V_{CC} = \text{MAX}, V_I = 4.5V$			'LS18	5.7	10	mA
				'LS19	17	30	
				'LS24	11	20	

†For conditions shown as MIN or MAX, use the appropriate value specified under recommended operating conditions.

‡All typical values are at $V_{CC} = 5V, T_A = 25^\circ\text{C}$.

§Not more than one output should be shorted at a time, and the duration of the short-circuit should not exceed one second.

switching characteristics, $V_{CC} = 5V, T_A = 25^\circ\text{C}$, see figure 1

PARAMETER	FROM (INPUT)	TO (OUTPUT)	TEST CONDITIONS	'LS18			'LS19			'LS24			UNIT
				MIN	TYP	MAX	MIN	TYP	MAX	MIN	TYP	MAX	
t_{PLH}	Any	Y	$R_L = 2 \text{ k}\Omega, C_L = 15 \text{ pF}$	13		20	13		20	13		20	ns
t_{PHL}	Any	Y		37		55	18		30	25		40	ns

t_{PLH} = Propagation delay time, low-to-high-level output

t_{PHL} = Propagation delay time, high-to-low-level output

TYPES SN74LS18, SN74LS19, SN74LS24
 SCHMITT-TRIGGER POSITIVE-NAND GATES
 AND INVERTERS WITH TOTEM-POLE OUTPUTS

PARAMETER MEASUREMENT INFORMATION

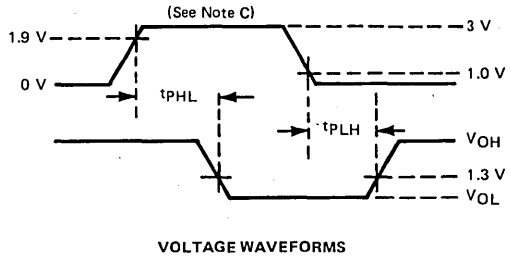
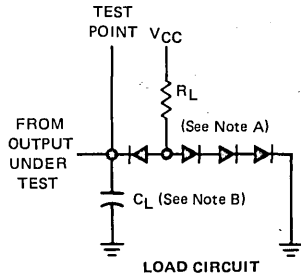

- NOTES: A. All diodes are IN3064 or equivalent.
 B. C_L includes probe and circuit capacitance.
 C. The generator characteristics are: P_{RR} = 1MHz, t_r = 15 ns,
 t_p = 6 ns, Z_{out} = 50 Ω.

FIGURE 1

3

TTL DEVICES

TYPES SN5420, SN54H20, SN54L20, SN54LS20, SN54S20, SN7420, SN74H20, SN74LS20, SN74S20 DUAL 4-INPUT POSITIVE-NAND GATES

REVISED DECEMBER 1983

- Package Options Include Both Plastic and Ceramic Chip Carriers in Addition to Plastic and Ceramic DIPs
- Dependable Texas Instruments Quality and Reliability

description

These devices contain two independent 4-input NAND gates.

The SN5420, SN54H20, SN54L20, SN54LS20 and SN54S20 are characterized for operation over the full military range of -55°C to 125°C . The SN7420, SN74H20, SN74LS20 and SN74S20 are characterized for operation from 0°C to 70°C .

FUNCTION TABLE (each gate)

INPUTS				OUTPUT
A	B	C	D	Y
H	H	H	H	L
L	X	X	X	H
X	L	X	X	H
X	X	L	X	H
X	X	X	L	H

logic diagram (each gate)

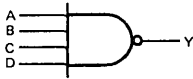

positive logic

$$Y = \overline{A \cdot B \cdot C \cdot D} \text{ or } Y = \overline{A + B + C + D}$$

SN5420, SN54H20, SN54L20 ... J PACKAGE
SN54LS20, SN54S20 ... J OR W PACKAGE
SN7420, SN74H20 ... J OR N PACKAGE
SN74LS20, SN74S20 ... D, J OR N PACKAGE

(TOP VIEW)

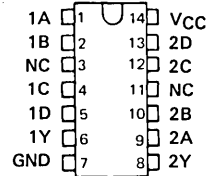

SN5420, SN54H20 ... W PACKAGE

(TOP VIEW)

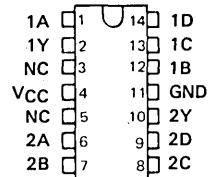

SN54LS20, SN54S20 ... FK PACKAGE
SN74LS20, SN74S20 ... FN PACKAGE

(TOP VIEW)

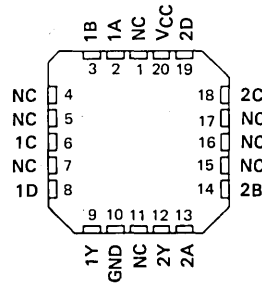

NC - No internal connection

3

TTL DEVICES

TYPES SN5420, SN54H20, SN54L20, SN54LS20, SN54S20, SN7420, SN74H20, SN74LS20, SN74S20 DUAL 4-INPUT POSITIVE-NAND GATES

schematics (each gate)

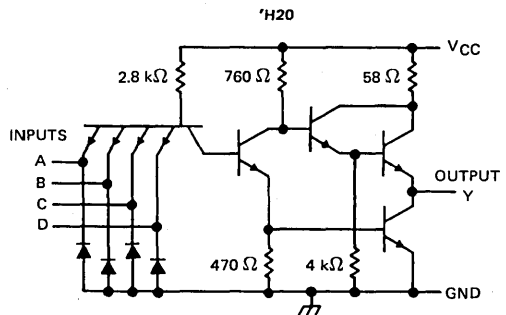
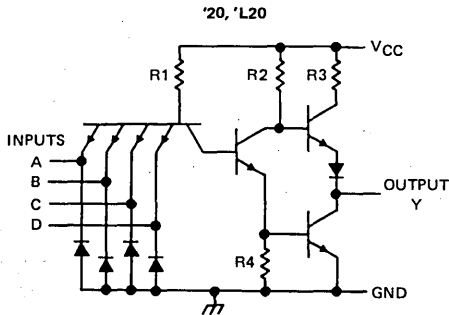

CIRCUIT	R1	R2	R3	R4
'20	4 kΩ	1.6 kΩ	130 Ω	1 kΩ
'L20	40 kΩ	20 kΩ	500 Ω	12 kΩ

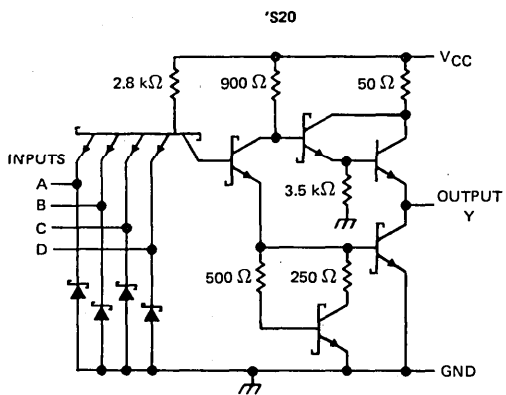
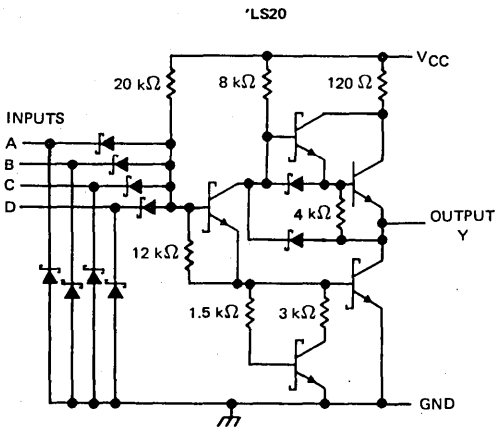

Resistor values shown are nominal.

absolute maximum ratings over operating free-air temperature range (unless otherwise noted)

Supply voltage, V_{CC} (see Note 1): '20, 'H20, 'LS20, 'S20	7 V
'L20	8 V
Input voltage: '20, 'H20, 'L20, 'S20	5.5 V
'LS20	7 V
Operating free-air temperature: SN54'	-55°C to 125°C
SN74'	0°C to 70°C
Storage temperature range	-65°C to 150°C

NOTE 1: Voltage values are with respect to network ground terminal.

TYPES SN5420, SN7420
DUAL 4-INPUT POSITIVE-NAND GATES

recommended operating conditions

	SN5420			SN7420			UNIT
	MIN	NOM	MAX	MIN	NOM	MAX	
V _{CC} Supply voltage	4.5	5	5.5	4.75	5	5.25	V
V _{IH} High-level input voltage	2			2			V
V _{IL} Low-level input voltage	0.8			0.8			V
I _{OH} High-level output current	-0.4			-0.4			mA
I _{OL} Low-level output current	16			16			mA
T _A Operating free-air temperature	-55			125			°C

electrical characteristics over recommended operating free-air temperature range (unless otherwise noted)

PARAMETER	TEST CONDITIONS †	SN5420			SN7420			UNIT
		MIN	TYP‡	MAX	MIN	TYP‡	MAX	
V _{IK}	V _{CC} = MIN, I _I = -12 mA	-1.5			-1.5			V
V _{OH}	V _{CC} = MIN, V _{IL} = 0.8 V, I _{OH} = -0.4 mA	2.4	3.4		2.4	3.4		V
V _{OL}	V _{CC} = MIN, V _{IH} = 2 V, I _{OL} = 16 mA		0.2	0.4		0.2	0.4	V
I _I	V _{CC} = MAX, V _I = 5.5 V	1			1			mA
I _{IH}	V _{CC} = MAX, V _I = 2.4 V	40			40			µA
I _{IL}	V _{CC} = MAX, V _I = 0.4 V	-1.6			-1.6			mA
I _{OS} §	V _{CC} = MAX	-20		-55	-18		-55	mA
I _{CCH}	V _{CC} = MAX, V _I = 0 V		2	4		2	4	mA
I _{CCL}	V _{CC} = MAX, V _I = 4.5 V		6	11		6	11	mA

† For conditions shown as MIN or MAX, use the appropriate value specified under recommended operating conditions.

‡ All typical values are at V_{CC} = 5 V, T_A = 25°C.

§ Not more than one output should be shorted at a time.

switching characteristics, V_{CC} = 5 V, T_A = 25°C (see note 2)

PARAMETER	FROM (INPUT)	TO (OUTPUT)	TEST CONDITIONS		MIN	TYP	MAX	UNIT
t _{PLH}	Any	Y	R _L = 400 Ω,	C _L = 15 pF		12	22	ns
t _{PHL}						8	15	ns

NOTE 2: See General Information Section for load circuits and voltage waveforms.

3

TTL DEVICES

TYPES SN54H20, SN74H20 DUAL 4-INPUT POSITIVE-NAND GATES

recommended operating conditions

	SN54H20			SN74H20			UNIT
	MIN	NOM	MAX	MIN	NOM	MAX	
V _{CC} Supply voltage	4.5	5	5.5	4.75	5	5.25	V
V _{IH} High-level input voltage	2			2			V
V _{IL} Low-level input voltage				0.8			V
I _{OH} High-level output current				-0.5			mA
I _{OL} Low-level output current				20			mA
T _A Operating free-air temperature	-55			125			°C

electrical characteristics over recommended operating free-air temperature range (unless otherwise noted)

PARAMETER	TEST CONDITIONS †	MIN	TYP ‡	MAX	UNIT
V _{IK}	V _{CC} = MIN, I _I = -8 mA			-1.5	V
V _{OH}	V _{CC} = MIN, V _{IL} = 0.8 V, I _{OH} = -0.5 mA	2.4	3.5		V
V _{OL}	V _{CC} = MIN, V _{IH} = 2 V, I _{OL} = 20 mA		0.2	0.4	V
I _I	V _{CC} = MAX, V _I = 5.5 V			1	mA
I _{IH}	V _{CC} = MAX, V _I = 2.4 V			50	μA
I _{IL}	V _{CC} = MAX, V _I = 0.4 V			-2	mA
I _{OS} §	V _{CC} = MAX	-40		-100	mA
I _{CC}	V _{CC} = MAX, V _I = 0 V		5	8.4	mA
I _{CCL}	V _{CC} = MAX, V _I = 4.5 V		13	20	mA

† For conditions shown as MIN or MAX, use the appropriate value specified under recommended operating conditions.

‡ All typical values are at V_{CC} = 5 V, T_A = 25°C.

§ Not more than one output should be shorted at a time, and the duration of the short-circuit should not exceed one second.

switching characteristics, V_{CC} = 5 V, T_A = 25°C (see note 2)

PARAMETER	FROM (INPUT)	TO (OUTPUT)	TEST CONDITIONS	MIN	TYP	MAX	UNIT
t _{PLH}	Any	Y	R _L = 280 Ω, C _L = 25 pF		6	10	ns
t _{PHL}					7	10	ns

NOTE 2: See General Information Section for load circuits and voltage waveforms.

recommended operating conditions

	SN54L20			UNIT
	MIN	NOM	MAX	
V _{CC} Supply voltage	4.5	5	5.5	V
V _{IH} High-level input voltage	2			V
V _{IL} Low-level input voltage			0.7	V
I _{OH} High-level output current			-0.1	mA
I _{OL} Low-level output current			2	mA
T _A Operating free-air temperature	-55		125	°C

electrical characteristics over recommended operating free-air temperature range (unless otherwise noted)

PARAMETER	TEST CONDITIONS †	SN54L20			UNIT
		MIN	TYP ‡	MAX	
V _{OH}	V _{CC} = MIN, V _{IL} = 0.7 V, I _{OH} = -0.1 mA	2.4	3.3		V
V _{OL}	V _{CC} = MIN, V _{IH} = 2 V, I _{OL} = 2 mA		0.15	0.3	V
I _I	V _{CC} = MAX, V _I = 5.5 V			0.1	mA
I _{IH}	V _{CC} = MAX, V _I = 2.4 V			10	μA
I _{IL}	V _{CC} = MAX, V _I = 0.3 V			-0.18	mA
I _{OS} §	V _{CC} = MAX	-3		-15	mA
I _{CCH}	V _{CC} = MAX, V _I = 0 V		0.22	0.4	mA
I _{CCL}	V _{CC} = MAX, V _I = 4.5 V		0.58	1.02	mA

† For conditions shown as MIN or MAX, use the appropriate value specified under recommended operating conditions.

‡ All typical values are at V_{CC} = 5 V, T_A = 25°C.

§ Not more than one output should be shorted at a time.

switching characteristics, V_{CC} = 5 V, T_A = 25°C (see note 2)

PARAMETER	FROM (INPUT)	TO (OUTPUT)	TEST CONDITIONS	MIN	TYP	MAX	UNIT
t _{PLH}	Any	Y	R _L = 4 kΩ, C _L = 50 pF		35	60	ns
t _{PHL}					31	60	ns

NOTE 2: See General Information Section for load circuits and voltage waveforms.

3
TTL DEVICES

TYPES SN54LS20, SN74LS20 DUAL 4-INPUT POSITIVE-NAND GATES

recommended operating conditions

	SN54LS20			SN74LS20			UNIT
	MIN	NOM	MAX	MIN	NOM	MAX	
V _{CC} Supply voltage	4.5	5	5.5	4.75	5	5.25	V
V _{IH} High-level input voltage	2			2			V
V _{IL} Low-level input voltage			0.7			0.8	V
I _{OH} High-level output current			-0.4			-0.4	mA
I _{OL} Low-level output current			4			8	mA
T _A Operating free-air temperature	-55		125	0		70	°C

electrical characteristics over recommended operating free-air temperature range (unless otherwise noted)

PARAMETER	TEST CONDITIONS †	SN54LS20		SN74LS20		UNIT		
		MIN	TYP‡	MAX	MIN		TYP‡	MAX
V _{IK}	V _{CC} = MIN, I _I = -18 mA			-1.5		-1.5	V	
V _{OH}	V _{CC} = MIN, V _{IL} = MAX, I _{OH} = -0.4 mA	2.5	3.4	2.7	3.4		V	
V _{OL}	V _{CC} = MIN, V _{IH} = 2 V, I _{OL} = 4 mA		0.25	0.4		0.4	V	
	V _{CC} = MIN, V _{IH} = 2 V, I _{OL} = 8 mA				0.25	0.5		
I _I	V _{CC} = MAX, V _I = 7 V			0.1		0.1	mA	
I _{IH}	V _{CC} = MAX, V _I = 2.7 V			20		20	μA	
I _{IL}	V _{CC} = MAX, V _I = 0.4 V			-0.4		-0.4	mA	
I _{OS} §	V _{CC} = MAX	-20		-100	-20	-100	mA	
I _{CCH}	V _{CC} = MAX, V _I = 0 V		0.4	0.8		0.4	0.8	mA
I _{CCL}	V _{CC} = MAX, V _I = 4.5 V		1.2	2.2		1.2	2.2	mA

† For conditions shown as MIN or MAX, use the appropriate value specified under recommended operating conditions.

‡ All typical values are at V_{CC} = 5 V, T_A = 25°C.

§ Not more than one output should be shorted at a time, and the duration of the short-circuit should not exceed one second.

switching characteristics, V_{CC} = 5 V, T_A = 25°C (see note 2)

PARAMETER	FROM (INPUT)	TO (OUTPUT)	TEST CONDITIONS		MIN	TYP	MAX	UNIT
t _{PLH}	Any	Y	R _L = 2 kΩ,	C _L = 15 pF		9	15	ns
t _{PHL}						10	15	ns

NOTE 2: See General Information Section for load circuits and voltage waveforms.

3 TTL DEVICES

TYPES SN54S20, SN74S20 DUAL 4-INPUT POSITIVE-NAND GATES

recommended operating conditions

	SN54S20			SN74S20			UNIT
	MIN	NOM	MAX	MIN	NOM	MAX	
V _{CC} Supply voltage	4.5	5	5.5	4.75	5	5.25	V
V _{IH} High-level input voltage	2			2			V
V _{IL} Low-level input voltage			0.8			0.8	V
I _{OH} High-level output current			-1			-1	mA
I _{OL} Low-level output current			20			20	mA
T _A Operating free-air temperature	-55		125	0		70	°C

electrical characteristics over recommended operating free-air temperature range (unless otherwise noted)

PARAMETER	TEST CONDITIONS †	SN54S20			SN74S20			UNIT
		MIN	TYP‡	MAX	MIN	TYP‡	MAX	
V _{IK}	V _{CC} = MIN, I _I = -18 mA		-1.2			-1.2	V	
V _{OH}	V _{CC} = MIN, V _{IL} = 0.8 V, I _{OH} = -1 mA	2.5	3.4		2.7	3.4	V	
V _{OL}	V _{CC} = MIN, V _{IH} = 2 V, I _{OL} = 20 mA		0.5			0.5	V	
I _I	V _{CC} = MAX, V _I = 5.5 V		1			1	mA	
I _{IH}	V _{CC} = MAX, V _I = 2.7 V		50			50	μA	
I _{IL}	V _{CC} = MAX, V _I = 0.5 V		-2			-2	mA	
I _{OS} §	V _{CC} = MAX	-40	-100		-40	-100	mA	
I _{CCH}	V _{CC} = MAX, V _I = 0 V		5	8		5	8	mA
I _{CCL}	V _{CC} = MAX, V _I = 4.5 V		10	18		10	18	mA

† For conditions shown as MIN or MAX, use the appropriate value specified under recommended operating conditions.

‡ All typical values are at V_{CC} = 5 V, T_A = 25°C.

§ Not more than one output should be shorted at a time, and the duration of the short-circuit should not exceed one second.

switching characteristics, V_{CC} = 5 V, T_A = 25°C (see note 2)

PARAMETER	FROM (INPUT)	TO (OUTPUT)	TEST CONDITIONS		MIN	TYP	MAX	UNIT
t _{PLH}	A, B, C or D	Y	R _L = 280 Ω,	C _L = 15 pF		3	4.5	ns
t _{PHL}						3	5	ns
t _{PLH}			R _L = 280 Ω,	C _L = 50 pF		4.5		ns
t _{PHL}						5		ns

NOTE 2: See General Information Section for load circuits and voltage waveforms.

3

TTL DEVICES

TYPES SN54H21, SN54LS21, SN74H21, SN74LS21 DUAL 4-INPUT POSITIVE-AND GATES

REVISED APRIL 1985

- Package Options Include Both Plastic and Ceramic Chip Carriers in Addition to Plastic and Ceramic DIPs
- Dependable Texas Instruments Quality and Reliability

description

These devices contain two independent 4-input AND gates.

The SN54H21 and SN54LS21 are characterized for operation over the full military temperature range of -55°C to 125°C. The SN74H21 and SN74LS21 are characterized for operation from 0°C to 70°C.

FUNCTION TABLE (each gate)

INPUTS				OUTPUT
A	B	C	D	Y
H	H	H	H	H
L	X	X	X	L
X	L	X	X	L
X	X	L	X	L
X	X	X	L	L

logic diagram (each gate)

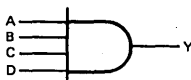

positive logic

$$Y = A \cdot B \cdot C \cdot D \text{ or } Y = \overline{\overline{A} + \overline{B} + \overline{C} + \overline{D}}$$

SN54H21 ... J PACKAGE
SN54LS21 ... J OR W PACKAGE
SN74H21 ... J OR N PACKAGE
SN74LS21 ... D, J OR N PACKAGE

(TOP VIEW)

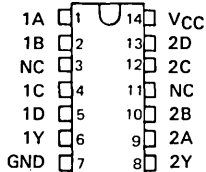

SN54H21 ... W PACKAGE

(TOP VIEW)

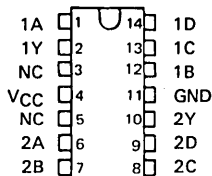

SN54LS21 ... FK PACKAGE

SN74LS21 ... FN PACKAGE

(TOP VIEW)

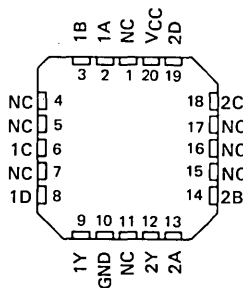

NC - No internal connection

TYPES SN54H21, SN54LS21,
SN74H21, SN74LS21
DUAL 4-INPUT POSITIVE-AND GATES

schematics (each gate)

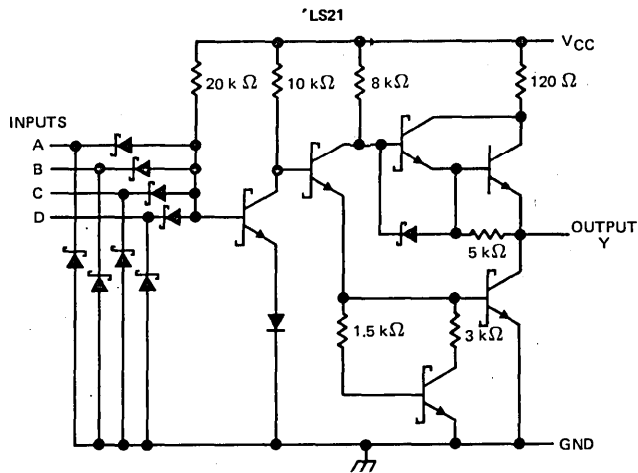
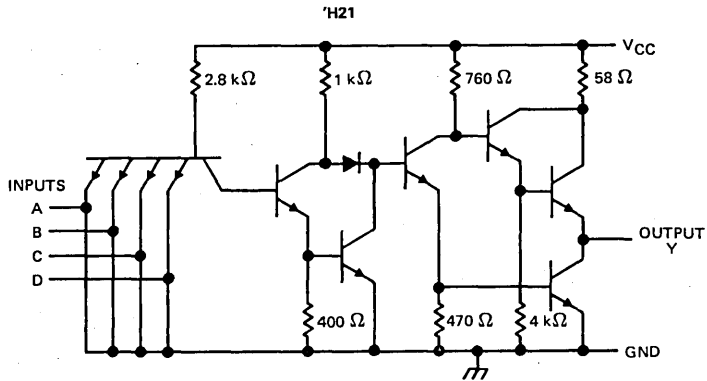

Resistor values shown are nominal.

absolute maximum ratings over operating free-air temperature range (unless otherwise noted)

Supply voltage, V_{CC} (see Note 1)	7 V
Input voltage: 'H21	5.5 V
'LS21	7 V
Operating temperature range: SN54'	-55°C to 125°C
SN74'	0°C to 70°C
Storage temperature range	-65°C to 150°C

NOTE 1: Voltage values are with respect to network ground terminal.

TYPES SN54H21, SN74H21
DUAL 4-INPUT POSITIVE-AND GATES

recommended operating conditions

	SN54H21			SN74H21			UNIT
	MIN	NOM	MAX	MIN	NOM	MAX	
V _{CC} Supply voltage	4.5	5	5.5	4.75	5	5.25	V
V _{IH} High-level input voltage	2			2			V
V _{IL} Low-level input voltage			0.8			0.8	V
I _{OH} High-level output current			-0.5			-0.5	mA
I _{OL} Low-level output current			20			20	mA
T _A Operating free-air temperature	-55		125	0		70	°C

electrical characteristics over recommended operating free-air temperature range (unless otherwise noted)

PARAMETER	TEST CONDITIONS †	SN54H21			SN74H21			UNIT
		MIN	TYP‡	MAX	MIN	TYP‡	MAX	
V _{IK}	V _{CC} = MIN, I _I = -8 mA			-1.5			-1.5	V
V _{OH}	V _{CC} = MIN, V _{IH} = 2 V, I _{OH} = -0.5 mA	2.4	3.4		2.4	3.4		V
V _{OL}	V _{CC} = MIN, V _{IL} = 0.8 V, I _{OL} = 20 mA		0.2	0.4		0.2	0.4	V
I _I	V _{CC} = MAX, V _I = 5.5 V			1			1	mA
I _{IH}	V _{CC} = MAX, V _I = 2.4 V			50			50	µA
I _{IL}	V _{CC} = MAX, V _I = 0.4 V			-2			-2	mA
I _{OS} §	V _{CC} = MAX	-40		-100	-40		-100	mA
I _{CCH}	V _{CC} = MAX, V _I = 4.5 V		12	20		12	20	mA
I _{CCL}	V _{CC} = MAX, V _I = 0 V		20	32		20	32	mA

† For conditions shown as MIN or MAX, use the appropriate value specified under recommended operating conditions.

‡ All typical values are at V_{CC} = 5 V, T_A = 25°C.

§ Not more than one output should be shorted at a time, and the duration of the short-circuit should not exceed one second.

switching characteristics, V_{CC} = 5 V, T_A = 25°C (see note 2)

PARAMETER	FROM (INPUT)	TO (OUTPUT)	TEST CONDITIONS		MIN	TYP	MAX	UNIT
t _{PLH}	Any	Y	R _L = 280 Ω,	C _L = 25 pF	7.6	12		ns
t _{PHL}					8.8	12		ns

NOTE 2: See General Information Section for load circuits and voltage waveforms.

3 TTL DEVICES

TYPES SN54LS21, SN74LS21 DUAL 4-INPUT POSITIVE-AND GATES

recommended operating conditions

	SN54LS21			SN74LS21			UNIT
	MIN	NOM	MAX	MIN	NOM	MAX	
V _{CC} Supply voltage	4.5	5	5.5	4.75	5	5.25	V
V _{IH} High-level input voltage	2			2			V
V _{IL} Low-level input voltage	0.7			0.8			V
I _{OH} High-level output current	-0.4			-0.4			mA
I _{OL} Low-level output current	4			8			mA
T _A Operating free-air temperature	-55	125		0	70		°C

electrical characteristics over recommended operating free-air temperature range (unless otherwise noted)

PARAMETER	TEST CONDITIONS †	SN54LS21			SN74LS21			UNIT
		MIN	TYP‡	MAX	MIN	TYP‡	MAX	
V _{IK}	V _{CC} = MIN, I _I = -18 mA	-1.5			-1.5			V
V _{OH}	V _{CC} = MIN, V _{IH} = 2 V, I _{OH} = -0.4 mA	2.5	3.4		2.7	3.4		V
V _{OL}	V _{CC} = MIN, V _{IL} = MAX, I _{OL} = 4 mA	0.25		0.4	0.25		0.4	V
	V _{CC} = MIN, V _{IL} = MAX, I _{OL} = 8 mA				0.35		0.5	
I _I	V _{CC} = MAX, V _I = 7 V	0.1			0.1			mA
I _{IH}	V _{CC} = MAX, V _I = 2.7 V	20			20			μA
I _{IL}	V _{CC} = MAX, V _I = 0.4 V	-0.4			-0.4			mA
I _{OS} §	V _{CC} = MAX	-20	-100		-20	-100		mA
I _{CCH}	V _{CC} = MAX, V _I = 4.5 V	1.2		2.4	1.2		2.4	mA
I _{CCL}	V _{CC} = MAX, V _I = 0 V	2.2		4.4	2.2		4.4	mA

† For conditions shown as MIN or MAX, use the appropriate value specified under recommended operating conditions.

‡ All typical values are at V_{CC} = 5 V, T_A = 25°C

§ Not more than one output should be shorted at a time, and the duration of the short-circuit should not exceed one second.

switching characteristics, V_{CC} = 5 V, T_A = 25°C (see note 2)

PARAMETER	FROM (INPUT)	TO (OUTPUT)	TEST CONDITIONS		MIN	TYP	MAX	UNIT
t _{PLH}	Any	Y	R _L = 2 kΩ,	C _L = 15 pF	8		15	ns
t _{PHL}					10		20	ns

NOTE 2: See General Information Section for load circuits and voltage waveforms.

3

TTL DEVICES

TYPES SN5422, SN54H22, SN54LS22, SN54S22, SN7422, SN74H22, SN74LS22, SN74S22 DUAL 4-INPUT POSITIVE-NAND GATES WITH OPEN-COLLECTOR OUTPUTS

REVISED DECEMBER 1983

- Package Options Include Both Plastic and Ceramic Chip Carriers in Addition to Plastic and Ceramic DIPs
- Dependable Texas Instruments Quality and Reliability

description

These devices contain two independent 4-input NAND gates. The open-collector outputs require pull-up resistors to perform correctly. They may be connected to other open-collector outputs to implement active-low wired-OR or active-high wired-AND functions. Open-collector devices are often used to generate higher V_{OH} levels.

The SN5422, SN54H22, SN54LS22 and SN54S22 are characterized for operation over the full military temperature range of -55°C to 125°C . The SN7422, SN74H22, SN74LS20 and SN74S22 are characterized for operation from 0°C to 70°C .

FUNCTION TABLE (each gate)

INPUTS				OUTPUT
A	B	C	D	Y
H	H	H	H	L
L	X	X	X	H
X	L	X	X	H
X	X	L	X	H
X	X	X	L	H

logic diagram (each gate)

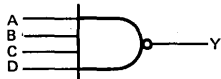

positive logic

$$Y = \overline{A \cdot B \cdot C \cdot D} \text{ or } Y = \overline{A} + \overline{B} + \overline{C} + \overline{D}$$

SN5422, SN54LS22, SN54S22 ... J OR W PACKAGE
SN54H22 ... J PACKAGE
SN7422, SN74H22 ... J OR N PACKAGE
SN74LS22, SN74S22 ... D, J OR N PACKAGE

(TOP VIEW)

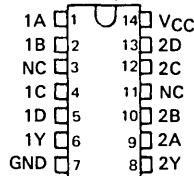

SN54H22 ... W PACKAGE

(TOP VIEW)

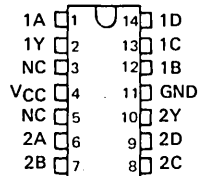

SN54LS22, SN54S22 ... FK PACKAGE
SN74LS22, SN74S22 ... FN PACKAGE

(TOP VIEW)

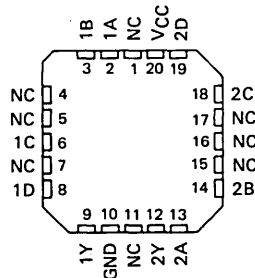

NC - No internal connection

3

TTL DEVICES

PRODUCTION DATA
This document contains information current as of publication date. Products conform to specifications per the terms of Texas Instruments standard warranty. Production processing does not necessarily include testing of all parameters.

TEXAS
INSTRUMENTS

POST OFFICE BOX 225012 • DALLAS, TEXAS 75265

**TYPES SN5422, SN54H22, SN54LS22, SN54S22
SN7422, SN74H22, SN74LS22, SN74S22
DUAL 4-INPUT POSITIVE-NAND GATES WITH OPEN-COLLECTOR OUTPUTS**

schematics (each gate)

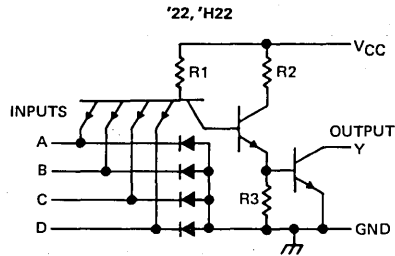

CIRCUIT	R1	R2	R3
'22	4 kΩ	1.6 kΩ	1 kΩ
'H22	2.8 kΩ	760 Ω	470 Ω

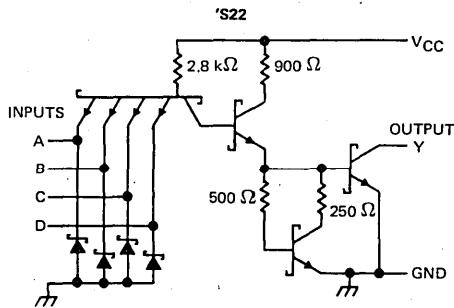
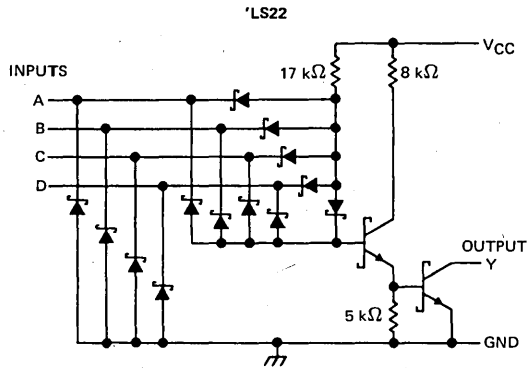

Resistor values shown are nominal.

absolute maximum ratings over operating free-air temperature range (unless otherwise noted)

Supply voltage, V_{CC} (see Note 1)	7 V
Input voltage: '22, 'H22, 'S22	5.5 V
'LS22	7 V
Operating free-air temperature: SN54'	-55°C to 125°C
SN74'	0°C to 70°C
Storage temperature range	-65°C to 150°C

NOTE 1: Voltage values are with respect to network ground terminal.

TYPES SN5422, SN7422
DUAL 4-INPUT POSITIVE-NAND GATES WITH OPEN-COLLECTOR OUTPUTS

recommended operating conditions

	SN5422			SN7422			UNIT
	MIN	NOM	MAX	MIN	NOM	MAX	
V _{CC} Supply voltage	4.5	5	5.5	4.75	5	5.25	V
V _{IH} High-level input voltage	2			2			V
V _{IL} Low-level input voltage			0.8			0.8	V
V _{OH} High-level output voltage			5.5			5.5	V
I _{OL} Low-level output current			16			16	mA
T _A Operating free-air temperature	-55		125	0		70	°C

electrical characteristics over recommended operating free-air temperature range (unless otherwise noted)

PARAMETER	TEST CONDITIONS†	MIN	TYP‡	MAX	UNIT	
V _{IK}	V _{CC} = MIN, I _I = -12 mA			-1.5	V	
I _{OH}	V _{CC} = MIN, V _{IL} = 0.8 V, V _{OH} = 5.5 V			0.25	mA	
V _{OL}	V _{CC} = MIN, V _{IH} = 2 V, I _{OL} = 16 mA		0.2	0.4	V	
I _I	V _{CC} = MAX, V _I = 5.5 V			1	mA	
I _{IH}	V _{CC} = MAX, V _I = 2.4 V			40	μA	
I _{IL}	V _{CC} = MAX, V _I = 0.4 V			-1.6	mA	
I _{CCH}	V _{CC} = MAX, V _I = 0 V			2	4	mA
I _{CCL}	V _{CC} = MAX, V _I = 4.5 V			6	11	mA

† For conditions shown as MIN or MAX, use the appropriate value specified under recommended operating conditions.

‡ All typical values are at V_{CC} = 5 V, T_A = 25°C.

switching characteristics, V_{CC} = 5 V, T_A = 25°C (see note 2)

PARAMETER	FROM (INPUT)	TO (OUTPUT)	TEST CONDITIONS	MIN	TYP	MAX	UNIT
t _{PLH}	Any	Y	R _L = 4 k Ω, C _L = 15 pF		35	45	ns
t _{PHL}			R _L = 400 Ω, C _L = 15 pF		8	15	ns

NOTE 2: See General Information Section for load circuits and voltage waveforms.

3

TTL DEVICES

TYPES SN54H22, SN74H22

DUAL 4-INPUT POSITIVE-NAND GATES WITH OPEN-COLLECTOR OUTPUTS

recommended operating conditions

	SN54H22			SN74H22			UNIT
	MIN	NOM	MAX	MIN	NOM	MAX	
V _{CC} Supply voltage	4.5	5	5.5	4.75	5	5.25	V
V _{IH} High-level input voltage	2			2			V
V _{IL} Low-level input voltage	0.8			0.8			V
V _{OH} High-level output voltage	5.5			5.5			V
I _{OL} Low-level output current	20			20			mA
T _A Operating free-air temperature	- 55			0			70 °C

electrical characteristics over recommended operating free-air temperature range (unless otherwise noted)

PARAMETER	TEST CONDITIONS†	MIN	TYP‡	MAX	UNIT
V _{IK}	V _{CC} = MIN, I _I = -8 mA			-1.5	V
I _{OH}	V _{CC} = MIN, V _{IL} = 0.8 V, V _{OH} = 5.5 V			0.25	mA
V _{OL}	V _{CC} = MIN, V _{IH} = 2 V, I _{OL} = 20 mA		0.2	0.4	V
I _I	V _{CC} = MAX, V _I = 5.5 V			1	mA
I _{IH}	V _{CC} = MAX, V _I = 2.4 V			50	μA
I _{IL}	V _{CC} = MAX, V _I = 0.4 V			-2	mA
I _{CCH}	V _{CC} = MAX, V _I = 0 V		5	8.4	mA
I _{CCL}	V _{CC} = MAX, V _I = 4.5 V		13	20	mA

† For conditions shown as MIN or MAX, use the appropriate value specified under recommended operating conditions.

‡ All typical values are at V_{CC} = 5 V, T_A = 25°C.

switching characteristics, V_{CC} = 5 V, T_A = 25°C (see note 2)

PARAMETER	FROM (INPUT)	TO (OUTPUT)	TEST CONDITIONS	MIN	TYP	MAX	UNIT
t _{PLH}	Any	Y	R _L = 280 Ω, C _L = 25 pF		10	15	ns
t _{PHL}					7.5	12	ns

NOTE 2: See General Information Section for load circuits and voltage waveforms.

TYPES SN54LS22, SN74LS22

DUAL 4-INPUT POSITIVE-NAND GATES WITH OPEN-COLLECTOR OUTPUTS

recommended operating conditions

	SN54LS22			SN74LS22			UNIT
	MIN	NOM	MAX	MIN	NOM	MAX	
V _{CC} Supply voltage	4.5	5	5.5	4.75	5	5.25	V
V _{IH} High-level input voltage	2			2			V
V _{IL} Low-level input voltage	0.7			0.8			V
V _{OH} High-level output voltage	5.5			5.5			V
I _{OL} Low-level output current	4			8			mA
T _A Operating free-air temperature	-55		125	0		70	°C

electrical characteristics over recommended operating free-air temperature range (unless otherwise noted)

PARAMETER	TEST CONDITIONS†	SN54LS22		SN74LS22		UNIT
		MIN	TYP‡	MAX	MIN	
V _{IK}	V _{CC} = MIN, I _I = -18 mA	-1.5		-1.5		V
I _{OH}	V _{CC} = MIN, V _{IL} = MAX, V _{OH} = 5.5 V	0.1		0.1		mA
V _{OL}	V _{CC} = MIN, V _{IH} = 2 V, I _{OL} = 4 mA	0.25	0.4	0.25	0.4	V
	V _{CC} = MIN, V _{IH} = 2 V, I _{OL} = 8 mA			0.35	0.5	
I _I	V _{CC} = MAX, V _I = 7 V	0.1		0.1		mA
I _{IH}	V _{CC} = MAX, V _I = 2.7 V	20		20		μA
I _{IL}	V _{CC} = MAX, V _I = 0.4 V	-0.4		-0.4		mA
I _{CCH}	V _{CC} = MAX, V _I = 0 V	0.4	0.8	0.4	0.8	mA
I _{CCL}	V _{CC} = MAX, V _I = 4.5 V	1.2	2.2	1.2	2.2	mA

† For conditions shown as MIN or MAX, use the appropriate value specified under recommended operating conditions.

‡ All typical values are at V_{CC} = 5 V, T_A = 25°C.

switching characteristics, V_{CC} = 5 V, T_A = 25°C (see note 2)

PARAMETER	FROM (INPUT)	TO (OUTPUT)	TEST CONDITIONS		MIN	TYP	MAX	UNIT
t _{PLH}	Any	Y	R _L = 2 kΩ,	C _L = 15 pF	17	32	ns	
t _{PHL}					15	28	ns	

NOTE 2: See General Information Section for load circuits and voltage waveforms.

3
TTL DEVICES

TYPES SN54S22, SN74S22

DUAL 4-INPUT POSITIVE-NAND GATES WITH OPEN-COLLECTOR OUTPUTS

recommended operating conditions

	SN54S22			SN74S22			UNIT		
	MIN	NOM	MAX	MIN	NOM	MAX			
V _{CC} Supply voltage	4.5	5	5.5	4.75	5	5.25	V		
V _{IH} High-level input voltage	2			2			V		
V _{IL} Low-level input voltage	0.8			0.8			V		
V _{OH} High-level output voltage	5.5			5.5			V		
I _{OL} Low-level output current	20			20			mA		
T _A Operating free-air temperature	-55			125			0	70	°C

electrical characteristics over recommended operating free-air temperature range (unless otherwise noted)

PARAMETER	TEST CONDITIONS†	MIN	TYP‡	MAX	UNIT	
V _{IK}	V _{CC} = MIN, I _I = -18 mA			-1.2	V	
I _{OH}	V _{CC} = MIN, V _{IL} = 0.8 V, V _{OH} = 5.5 V			0.25	mA	
V _{OL}	V _{CC} = MIN, V _{IH} = 2 V, I _{OL} = 20 mA			0.5	V	
I _I	V _{CC} = MAX, V _I = 5.5 V			1	mA	
I _{IH}	V _{CC} = MAX, V _I = 2.7 V			50	μA	
I _{IL}	V _{CC} = MAX, V _I = 0.5 V			-2	mA	
I _{CCH}	V _{CC} = MAX, V _I = 0 V			3	6.6	mA
I _{CCL}	V _{CC} = MAX, V _I = 4.5 V			10	18	mA

† For conditions shown as MIN or MAX, use the appropriate value specified under recommended operating conditions.

‡ All typical values are at V_{CC} = 5 V, T_A = 25°C.

switching characteristics, V_{CC} = 5 V, T_A = 25°C (see note 2)

PARAMETER	FROM (INPUT)	TO (OUTPUT)	TEST CONDITIONS		MIN	TYP	MAX	UNIT
t _{PLH}	Any	Y	R _L = 280 Ω,	C _L = 15 pF	2	5	7.5	ns
t _{PHL}					2	4.5	7	ns
t _{PLH}			R _L = 280 Ω,	C _L = 50 pF	7.5		ns	
t _{PHL}					7		ns	

NOTE 2: See General Information Section for load circuits and voltage waveforms.

TYPES SN5423, SN5425, SN7423, SN7425 DUAL 4-INPUT NOR GATES WITH STROBE

REVISED DECEMBER 1983

- Package Options Include Plastic and Ceramic DIPs
- Dependable Texas Instruments Quality and Reliability

description

These devices contain dual 4-input positive NOR gates with strobe. The SN5423 and SN7423 are expandable, and perform the Boolean functions:

$$1Y = \overline{1G(1A+1B+1C+1D)} + X \text{ and}$$

$$2Y = 2G(2A+2B+2C+2D)$$

with X = output of SN5460/SN7460. The SN5425 and SN7425 perform the Boolean function:

$$Y = \overline{G(A+B+C+D)}$$

The SN5423 and the SN5425 are characterized for operation over the full military temperature range of -55°C to 125°C . The SN7423 and the SN7425 are characterized for operation from 0°C to 70°C .

schematic (each gate)

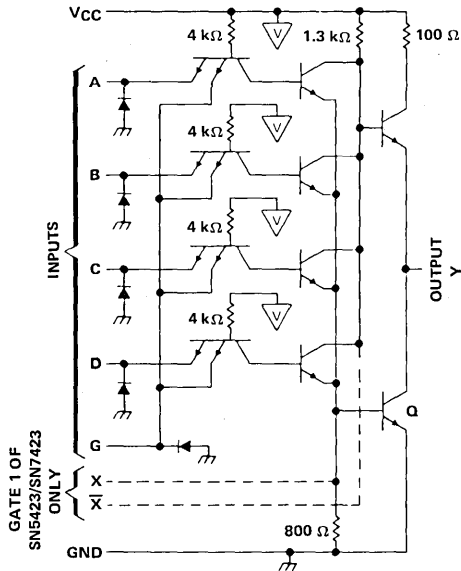

- Notes:
- Component values shown are nominal.
 - Both expander inputs are used simultaneously for expanding.
 - If expander is not used leave X and X open.
 - A total of four expander gates can be connected to the expander inputs.

- VCC bus

SN5423 ... J OR W PACKAGE
SN7423 ... J OR N PACKAGE
(TOP VIEW)

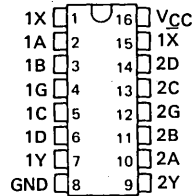

SN5425 ... J OR W PACKAGE
SN7425 ... J OR N PACKAGE
(TOP VIEW)

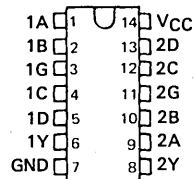

logic diagram

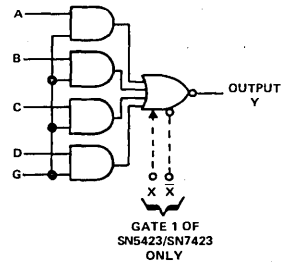

TRUTH TABLE

INPUTS					OUTPUT
A	B	C	D	G	Y
H	X	X	X	H	L
X	H	X	X	H	L
X	X	H	X	H	L
X	X	X	H	H	L
L	L	L	L	X	H
X	X	X	X	L	H

Expander inputs are open.
H = high level, L = low level, X = irrelevant

3

TTL DEVICES

TEXAS
INSTRUMENTS

POST OFFICE BOX 225012 • DALLAS, TEXAS 75265

3-123

TYPES SN5423, SN5425, SN7423, SN7425

DUAL 4-INPUT NOR GATES WITH STROBE

absolute maximum ratings over operating free-air temperature range (unless otherwise noted)

Supply voltage V_{CC} (see Note 1)	7 V
Input voltage (see Note 1)	5.5 V
Intermitter voltage (see Note 2)	5.5 V
Operating free-air temperature range: SN5423, SN5425 Circuits	-55°C to 125°C
SN7423, SN7425 Circuits	0°C to 70°C
Storage temperature range	-65°C to 150°C

- NOTES: 1. Voltage values, except intermitter voltage, are with respect to network ground terminal.
 2. This is the voltage between two emitters of a multiple-emitter transistor.

recommended operating conditions

		'23, '25			UNIT
		MIN	NOM	MAX	
V_{CC} Supply voltage	54 Family	4.5	5	5.5	V
	74 Family	4.75	5	5.25	
V_{IH} High-level input voltage		2			V
V_{IL} Low-level input voltage		0.8			V
I_{OH} High-level output current		-0.8			mA
I_{OL} Low-level output current	54 Family	16			mA
	74 Family	16			
T_A Operating free-air temperature range	54 Family	-55	125		°C
	74 Family	0	70		

The '23 is designed for use with up to four '60 expanders.

electrical characteristics over recommended operating free-air temperature range (unless otherwise noted)

PARAMETER		TEST CONDITIONS†	MIN	TYP‡	MAX	UNIT	
V_I		$V_{CC} = \text{MIN}$, $I_I = -12 \text{ mA}$			-1.5	V	
V_{OH}		$V_{CC} = \text{MIN}$, $V_{IL} = 0.8 \text{ V}$, $I_{OH} = -0.8 \text{ mA}$	2.4	3.4		V	
V_{OL}		$V_{CC} = \text{MIN}$, $V_{IH} = 2 \text{ V}$, $I_{OL} = 16 \text{ mA}$		0.2	0.4	V	
I_I		$V_{CC} = \text{MAX}$, $V_I = 5.5 \text{ V}$			1	mA	
I_{IH}	data inputs	$V_{CC} = \text{MAX}$, $V_I = 2.4 \text{ V}$			40	µA	
	strobe inputs				160		
I_{IL}	data inputs	$V_{CC} = \text{MAX}$, $V_I = 0.4 \text{ V}$			-1.6	mA	
	strobe inputs				-6.4		
$I_{OS}§$		$V_{CC} = \text{MAX}$	54 Family		-20	-55	mA
			74 Family		-18	-55	
I_{CCH}		$V_{CC} = \text{MAX}$, All inputs at 0 V		8	16	mA	
I_{CCL}		$V_{CC} = \text{MAX}$, All inputs at 5 V		10	19	mA	

† For conditions shown as MIN or MAX, use the appropriate value specified under recommended operating conditions for the applicable device type. Expander inputs X and \bar{X} are open.

‡ All typical values are at $V_{CC} = 5 \text{ V}$, $T_A = 25^\circ \text{C}$.

§ Not more than one output should be shorted at a time.

TYPES SN5423, SN5425, SN7423, SN7425
DUAL 4-INPUT NOR GATES WITH STROBE

electrical characteristics (SN5423 circuits) using expander inputs, $V_{CC} = 4.5 \text{ V}$, $T_A = -55^\circ\text{C}$

PARAMETER	TEST CONDITIONS	MIN	TYP†	MAX	UNIT
$I_{\bar{X}}$	Expander current $V_{X\bar{X}} = 0.4 \text{ V}$, $I_{OL} = 16 \text{ mA}$			-3.5	mA
$V_{BE(Q)}$	Base-Emitter voltage of output transistor (Q) $I_{OL} = 16 \text{ mA}$, $I_X + I_{\bar{X}} = 0.41 \text{ mA}$, $R_{X\bar{X}} = 0$			1.1	V
V_{OH}	High-level output voltage $I_{OH} = -0.4 \text{ mA}$, $I_X = 0.15 \text{ mA}$, $I_{\bar{X}} = -0.15 \text{ mA}$	2.4	3.4		V
V_{OL}	Low-level output voltage $I_{OL} = 16 \text{ mA}$, $I_X + I_{\bar{X}} = 0.3 \text{ mA}$, $R_{X\bar{X}} = 114 \Omega$	0.2	0.4		V

electrical characteristics (SN7423 circuits) using expander inputs, $V_{CC} = 4.75 \text{ V}$, $T_A = 0^\circ\text{C}$

PARAMETER	TEST CONDITIONS	MIN	TYP†	MAX	UNIT
$I_{\bar{X}}$	Expander current $V_{X\bar{X}} = 0.4 \text{ V}$, $I_{OL} = 16 \text{ mA}$			-3.8	mA
$V_{BE(Q)}$	Base-Emitter voltage of output transistor (Q) $I_{OL} = 16 \text{ mA}$, $I_X + I_{\bar{X}} = 0.62 \text{ mA}$, $R_{X\bar{X}} = 0$			1	V
V_{OH}	High-level output voltage $I_{OH} = -0.4 \text{ mA}$, $I_X = 0.27 \text{ mA}$, $I_{\bar{X}} = -0.27 \text{ mA}$	2.4	3.4		V
V_{OL}	Low-level output voltage $I_{OL} = 16 \text{ mA}$, $I_X + I_{\bar{X}} = 0.43 \text{ mA}$, $R_{X\bar{X}} = 130 \Omega$	0.2	0.4		V

† All typical values are at $V_{CC} = 5 \text{ V}$, $T_A = 25^\circ\text{C}$.

switching characteristics, $V_{CC} = 5 \text{ V}$, $T_A = 25^\circ\text{C}$, $N = 10$, (see note 3)

PARAMETER	TEST CONDITIONS	MIN	TYP	MAX	UNIT
t_{PLH}	$R_L = 400 \Omega$, $C_L = 15 \text{ pF}$		13	22	ns
t_{PHL}	$R_L = 400 \Omega$, $C_L = 15 \text{ pF}$		8	15	ns

NOTE 3: Switching characteristics of the SN5423 and SN7424 are tested with the expander pins open.

3

TTL DEVICES

TYPES SN5426, SN54LS26, SN7426, SN74LS26 QUADRUPLE 2-INPUT HIGH-VOLTAGE INTERFACE POSITIVE-NAND GATES

REVISED DECEMBER 1983

- For Driving Low-Threshold-Voltage MOS Inputs

description

These 2-input open-collector NAND gates feature high-output voltage ratings for interfacing with low-threshold-voltage MOS logic circuits or other 12-volt systems. Although the output is rated to withstand 15 volts, the V_{CC} terminal is connected to the standard 5-volt source.

The SN5426 and SN54LS26 are characterized for operation over the full military temperature range of -55°C to 125°C . The SN7426 and SN74LS26 are characterized for operation from 0°C to 70°C .

logic diagram (each gate)



SN5426 . . . J PACKAGE
SN54LS26 . . . J OR W PACKAGE
SN7426 . . . J OR N PACKAGE
SN74LS26 . . . D, J OR N PACKAGE

(TOP VIEW)

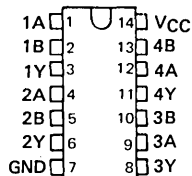

SN54LS26 . . . FK PACKAGE
SN74LS26 . . . FN PACKAGE

(TOP VIEW)

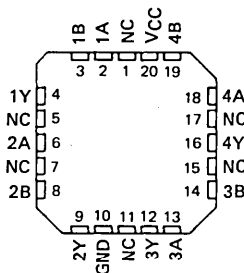

NC - No internal connection

positive logic

$$Y = \overline{AB}$$

3

TTL DEVICES

PRODUCTION DATA

This document contains information current as of publication date. Products conform to specifications per the terms of Texas Instruments standard warranty. Production processing does not necessarily include testing of all parameters.

3-126

TEXAS
INSTRUMENTS

POST OFFICE BOX 225012 • DALLAS, TEXAS 75265

1283

TYPES SN5426, SN54LS26, SN7426, SN74LS26
 QUADRUPLE 2-INPUT
 HIGH-VOLTAGE INTERFACE POSITIVE-NAND GATES

schematics

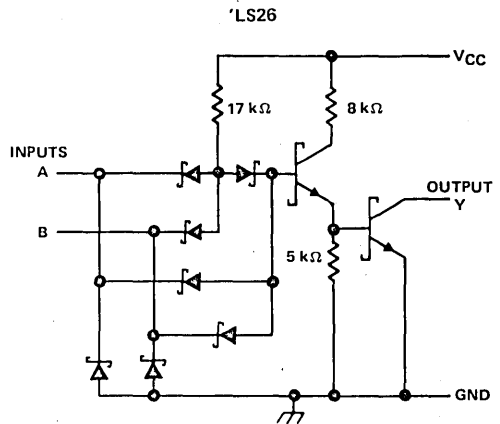
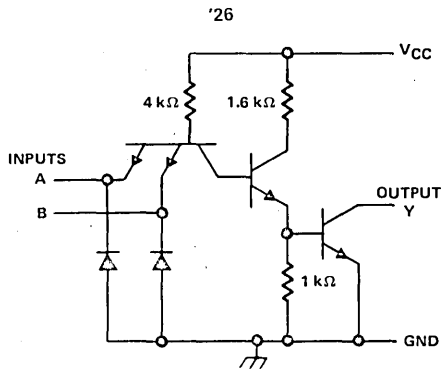

Resistor values shown are nominal.

absolute maximum ratings over operating free-air temperature (unless otherwise noted)

Supply voltage, V_{CC} (see Note 1)	7 V
Input voltage: '26	5.5 V
'LS26	7 V
Operating free-air temperature: SN54'	-55°C to 125°C
SN74'	0°C to 70°C
Storage temperature range	-65°C to 150°C

NOTE 1: Voltage values are with respect to network ground terminal.

3

TTL DEVICES

TYPES SN5426, SN7426
QUADRUPLE 2-INPUT
HIGH-VOLTAGE INTERFACE POSITIVE-NAND GATES

recommended operating conditions

	SN5426			SN7426			UNIT
	MIN	NOM	MAX	MIN	NOM	MAX	
V _{CC} Supply voltage	4.5	5	5.5	4.75	5	5.25	V
V _{IH} High-level input voltage	2			2			V
V _{IL} Low-level input voltage	0.8			0.8			V
V _{OH} High-level output voltage	15			15			V
I _{OL} Low-level output current	16			16			mA
T _A Operating free-air temperature	- 55			125			°C

electrical characteristics over recommended operating free-air temperature range (unless otherwise noted)

PARAMETER	TEST CONDITIONS†	SN5426			SN7426			UNIT
		MIN	TYP‡	MAX	MIN	TYP‡	MAX	
V _{IK}	V _{CC} = MIN, I _I = - 12 mA	- 1.5			- 1.5			V
I _{OH}	V _{CC} = MIN, V _{IL} = 0.8 V, V _{OH} = 12 V	50			50			μA
	V _{CC} = MIN, V _{IL} = 0.8 V, V _{OH} = 15 V	1			1			mA
V _{OL}	V _{CC} = MIN, V _{IH} = 2 V, I _{OL} = 16 mA	0.4			0.4			V
I _I	V _{CC} = MAX, V _I = 5.5 V	1			1			mA
I _{IH}	V _{CC} = MAX, V _{IH} = 2.4 V	40			40			μA
I _{IL}	V _{CC} = MAX, V _{IL} = 0.4 V	- 1.6			- 1.6			mA
I _{CCH}	V _{CC} = MAX, V _I = 0 V	4 8		4 8		mA		
I _{CCL}	V _{CC} = MAX, V _I = 4.5 V	12 22		12 22		mA		

† For conditions shown as MIN or MAX, use the appropriate value specified under recommended operating conditions.

‡ All typical values are at V_{CC} = 5 V, T_A = 25°C.

switching characteristics, V_{CC} = 5 V, T_A = 25°C (see note 2)

PARAMETER	FROM (INPUT)	TO (OUTPUT)	TEST CONDITIONS	MIN	TYP	MAX	UNIT
t _{PLH}	A or B	Y	R _L = 1 kΩ, C _L = 15 pF	16 24		ns	
t _{PHL}				11 17		ns	

NOTE 2: See General Information Section for load circuits and voltage waveforms.

3 TTL DEVICES

TYPES SN54LS26, SN74LS26
 QUADRUPLE 2-INPUT
 HIGH-VOLTAGE INTERFACE POSITIVE-NAND GATES

recommended operating conditions

	SN54LS26			SN74LS26			UNIT
	MIN	NOM	MAX	MIN	NOM	MAX	
V_{CC} Supply voltage	4.5	5	5.5	4.75	5	5.25	V
V_{IH} High-level input voltage	2			2			V
V_{IL} Low-level input voltage				0.7			V
V_{OH} High-level output voltage				15			V
I_{OL} Low-level output current				4			mA
T_A Operating free-air temperature	-55			125			$^{\circ}$ C

electrical characteristics over recommended operating free-air temperature range (unless otherwise noted)

PARAMETER	TEST CONDITIONS†	SN54LS26		SN74LS26		UNIT
		MIN	TYP‡ MAX	MIN	TYP‡ MAX	
V_{IK}	$V_{CC} = \text{MIN}$, $I_I = -18 \text{ mA}$	-1.5		-1.5		V
I_{OH}	$V_{CC} = \text{MIN}$, $V_{IL} = \text{MAX}$, $V_{OH} = 12 \text{ V}$	50		50		μ A
	$V_{CC} = \text{MIN}$, $V_{IL} = \text{MAX}$, $V_{OH} = 15 \text{ V}$	1		1		mA
V_{OL}	$V_{CC} = \text{MIN}$, $V_{IH} = 2 \text{ V}$, $I_{OL} = 4 \text{ mA}$	0.25	0.4	0.25	0.4	V
	$V_{CC} = \text{MIN}$, $V_{IH} = 2 \text{ V}$, $I_{OL} = 8 \text{ mA}$			0.35	0.5	
I_I	$V_{CC} = \text{MAX}$, $V_I = 7 \text{ V}$	0.1		0.1		mA
I_{IH}	$V_{CC} = \text{MAX}$, $V_{IH} = 2.7 \text{ V}$	20		20		μ A
I_{IL}	$V_{CC} = \text{MAX}$, $V_{IL} = 0.4 \text{ V}$	-0.4		-0.4		mA
I_{CCH}	$V_{CC} = \text{MAX}$, $V_I = 0 \text{ V}$	0.8	1.6	0.8	1.6	mA
I_{CCL}	$V_{CC} = \text{MAX}$, $V_I = 4.5 \text{ V}$	2.4	4.4	2.4	4.4	

† For conditions shown as MIN or MAX, use the appropriate value specified under recommended operating conditions.

‡ All typical values are at $V_{CC} = 5 \text{ V}$, $T_A = 25^{\circ}\text{C}$.

switching characteristics, $V_{CC} = 5 \text{ V}$, $T_A = 25^{\circ}\text{C}$ (see note 2)

PARAMETER	FROM (INPUT)	TO (OUTPUT)	TEST CONDITIONS	MIN	TYP	MAX	UNIT	
t_{PLH}	A or B	Y	$R_L = 2 \text{ k}\Omega$, $C_L = 15 \text{ pF}$			17	32	ns
t_{PHL}				15	28	ns		

NOTE 2: See General Information Section for load circuits and voltage waveforms.

3

TTL DEVICES

TYPES SN5427, SN54LS27, SN7427, SN74LS27 TRIPLE 3-INPUT POSITIVE-NOR GATES

REVISED DECEMBER 1983

- Package Options Include Both Plastic and Ceramic Chip Carriers in Addition to Plastic and Ceramic DIPs
- Dependable Texas Instruments Quality and Reliability

description

These devices contain three independent 3-input NOR gates.

The SN5427 and SN54LS27 are characterized for operation over the full military temperature range of -55°C to 125°C. The SN7427 and SN74LS27 are characterized for operation from 0°C to 70°C.

SN5427, SN54LS27 ... J OR W PACKAGE
SN7427 ... J OR N PACKAGE
SN74LS27 ... D, J OR N PACKAGE
(TOP VIEW)

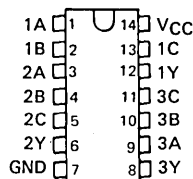

SN54LS27 ... FK PACKAGE
SN74LS27 ... FN PACKAGE
(TOP VIEW)

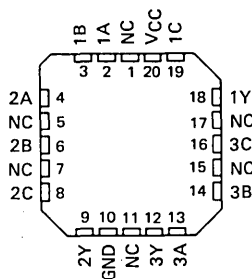

NC - No internal connection

FUNCTION TABLE (each gate)

INPUTS			OUTPUT
A	B	C	Y
H	X	X	L
X	H	X	L
X	X	H	L
L	L	L	H

logic diagram (each gate)



positive logic

$$Y = \overline{A + B + C} \text{ or } Y = \overline{A} \cdot \overline{B} \cdot \overline{C}$$

3

TTL DEVICES

TYPES SN5427, SN54LS27, SN7427, SN74LS27
TRIPLE 3-INPUT POSITIVE-NOR GATES

schematics (each gate)

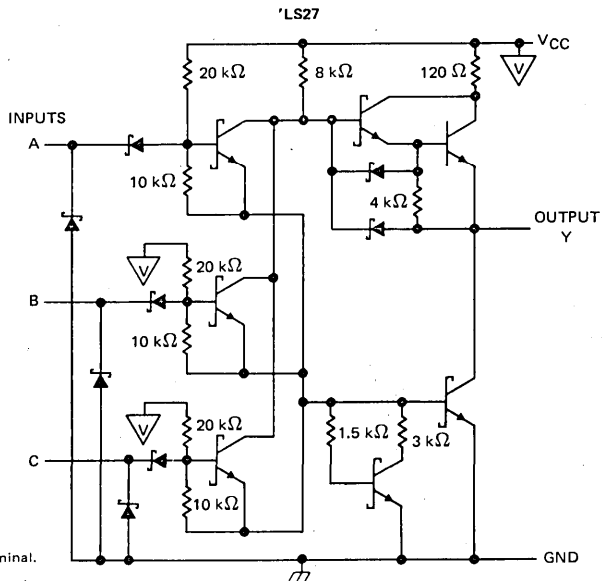
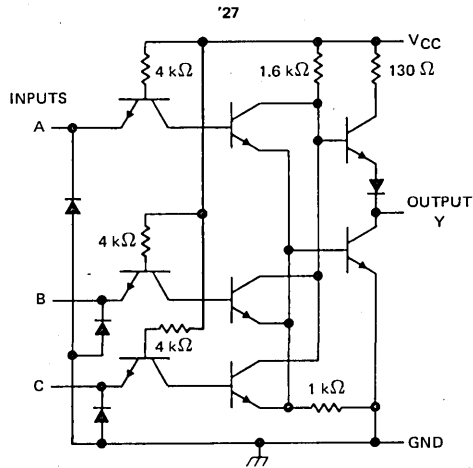

Resistor values shown are nominal.

absolute maximum ratings over operating free-air temperature range (unless otherwise noted)

Supply voltage, V_{CC} (see Note 1)	7 V
Input voltage: '27	5.5 V
'LS27	7 V
Operating free-air temperature: SN54'	-55°C to 125°C
SN74'	0°C to 70°C
Storage temperature range	-65°C to 150°C

NOTE 1: Voltage values are with respect to network ground terminal.

3
TTL DEVICES

TYPES SN5427, SN7427
TRIPLE 3-INPUT POSITIVE-NOR GATES

recommended operating conditions

	SN5427			SN7427			UNIT
	MIN	NOM	MAX	MIN	NOM	MAX	
V _{CC} Supply voltage	4.5	5	5.5	4.75	5	5.25	V
V _{IH} High-level input voltage	2			2			V
V _{IL} Low-level input voltage			0.8			0.8	V
I _{OH} High-level output current			-0.8			-0.8	mA
I _{OL} Low-level output current			16			16	mA
T _A Operating free-air temperature	-55		125	0		70	°C

electrical characteristics over recommended operating free-air temperature range (unless otherwise noted)

PARAMETER	TEST CONDITIONS †	SN5427		SN7427		UNIT		
		MIN	TYP ‡	MAX	MIN		TYP ‡	MAX
V _{IK}	V _{CC} = MIN, I _I = -12 mA			-1.5		-1.5	V	
V _{OH}	V _{CC} = MIN, V _{IL} = 0.8 V, I _{OH} = -0.8 mA	2.4	3.4		2.4	3.4	V	
V _{OL}	V _{CC} = MIN, V _{IH} = 2 V, I _{OL} = 16 mA		0.2	0.4		0.2	0.4	V
I _I	V _{CC} = MAX, V _I = 5.5 V			1		1	mA	
I _{IH}	V _{CC} = MAX, V _I = 2.4 V			40		40	µA	
I _{IL}	V _{CC} = MAX, V _I = 0.4 V			-1.6		-1.6	mA	
I _{OS} §	V _{CC} = MAX	-20		-55	-18	-55	mA	
I _{CCH}	V _{CC} = MAX, V _I = 0 V		10	16		10	16	mA
I _{CCL}	V _{CC} = MAX, See Note 2		16	26		16	26	mA

† For conditions shown as MIN or MAX, use the appropriate value specified under recommended operating conditions.

‡ All typical values are at V_{CC} = 5 V, T_A = 25°C.

§ Not more than one output should be shorted at a time.

NOTE 2: One input at 4.5 V, all others at GND.

switching characteristics, V_{CC} = 5 V, T_A = 25°C (see note 3)

PARAMETER	FROM (INPUT)	TO (OUTPUT)	TEST CONDITIONS	MIN	TYP	MAX	UNIT
t _{PLH}	A, B or C	Y	R _L = 400 Ω, C _L = 15 pF		10	15	ns
t _{PHL}					7	11	ns

NOTE 3: See General Information Section for load circuits and voltage waveforms.

3 TTL DEVICES

TYPES SN54LS27, SN74LS27
TRIPLE 3-INPUT POSITIVE-NOR GATES

recommended operating conditions

	SN54LS27			SN74LS27			UNIT
	MIN	NOM	MAX	MIN	NOM	MAX	
V _{CC} Supply voltage	4.5	5	5.5	4.75	5	5.25	V
V _{IH} High-level input voltage	2			2			V
V _{IL} Low-level input voltage			0.7			0.8	V
I _{OH} High-level output current			-0.4			-0.4	mA
I _{OL} Low-level output current			4			8	mA
T _A Operating free-air temperature	-55		125	0		70	°C

electrical characteristics over recommended operating free-air temperature range (unless otherwise noted)

PARAMETER	TEST CONDITIONS †	SN54LS27		SN74LS27		UNIT		
		MIN	TYP ‡	MAX	MIN		TYP ‡	MAX
V _{IK}	V _{CC} = MIN, I _I = -18 mA			-1.5		-1.5	V	
V _{OH}	V _{CC} = MIN, V _{IL} = MAX, I _{OH} = -0.4 mA	2.5	3.4		2.7	3.4	V	
V _{OL}	V _{CC} = MIN, V _{IH} = 2 V, I _{OL} = 4 mA		0.25	0.4		0.25	0.4	V
	V _{CC} = MIN, V _{IH} = 2 V, I _{OL} = 8 mA					0.35	0.5	
I _I	V _{CC} = MAX, V _I = 7 V			0.1		0.1	mA	
I _{IH}	V _{CC} = MAX, V _I = 2.7 V			20		20	μA	
I _{IL}	V _{CC} = MAX, V _I = 0.4 V			-0.4		-0.4	mA	
I _{OS} §	V _{CC} = MAX	-20		-100	-20		-100	mA
I _{CCH}	V _{CC} = MAX, V _I = 0 V		2	4		2	4	mA
I _{CCL}	V _{CC} = MAX, See Note 2		3.4	6.8		3.4	6.8	mA

† For conditions shown as MIN or MAX, use the appropriate value specified under recommended operating conditions.

‡ All typical values are at V_{CC} = 5 V, T_A = 25°C.

§ Not more than one output should be shorted at a time, and the duration of the short-circuit should not exceed one second.

NOTE 2: One input at 4.5 V, all others at GND.

switching characteristics, V_{CC} = 5 V, T_A = 25°C (see note 3)

PARAMETER	FROM (INPUT)	TO (OUTPUT)	TEST CONDITIONS		MIN	TYP	MAX	UNIT
t _{PLH}	A, B or C	Y	R _L = 2 kΩ,	C _L = 15 pF		10	15	ns
t _{PHL}						10	15	ns

NOTE 3: See General Information Section for load circuits and voltage waveforms.

3

TTL DEVICES

TYPES SN5428, SN54LS28, SN7428, SN74LS28 QUADRUPLE 2-INPUT POSITIVE-NOR BUFFERS

REVISED DECEMBER 1983

- Package Options Include Both Plastic and Ceramic Chip Carriers in Addition to Plastic and Ceramic DIPs
- Dependable Texas Instruments Quality and Reliability

description

These devices contain four independent 2-input NOR buffer gates.

The SN5428, and SN54LS28 are characterized for operation over the full military temperature range of -55°C to 125°C. The SN7428, and SN74LS28 are characterized for operation from 0°C to 70°C.

FUNCTION TABLE (each gate)

INPUTS		OUTPUT
A	B	Y
H	X	L
X	H	L
L	L	H

logic diagram (each gate)



positive logic

$$Y = \overline{A + B} \text{ or } Y = \overline{A \cdot B}$$

SN5428, SN54LS28 ... J OR W PACKAGE
SN7428 ... J OR N PACKAGE
SN74LS28 ... D, J OR N PACKAGE
(TOP VIEW)

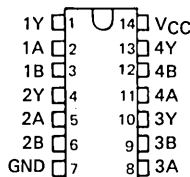

SN54LS28 ... FK PACKAGE
SN74LS28 ... FN PACKAGE
(TOP VIEW)

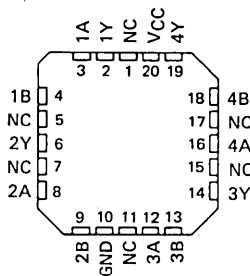

NC - No internal connection

3

TTL DEVICES

TYPES SN5428, SN54LS28, SN7428, SN74LS28 QUADRUPLE 2-INPUT POSITIVE-NOR BUFFERS

schematics (each gate)

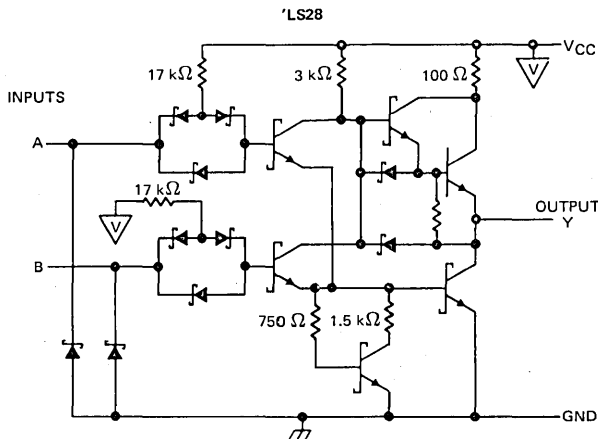
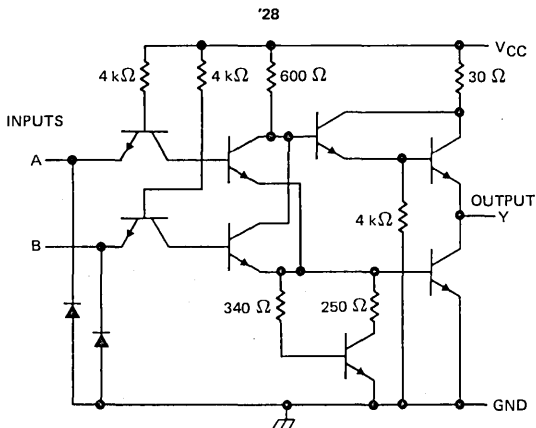

Resistor values shown are nominal.

absolute maximum ratings over operating free-air temperature range (unless otherwise noted)

Supply voltage, V_{CC} (see Note 1)	7 V
Input voltage: '28	5.5 V
'LS28	7 V
Operating free-air temperature: SN54'	-55°C to 125°C
SN74'	0°C to 70°C
Storage temperature range	-65°C to 150°C

NOTE 1: Voltage values are with respect to network ground terminal.

3
TTL DEVICES

TYPES SN5428, SN7428
QUADRUPLE 2-INPUT POSITIVE-NOR BUFFERS

recommended operating conditions

	SN5428			SN7428			UNIT
	MIN	NOM	MAX	MIN	NOM	MAX	
V _{CC} Supply voltage	4.5	5	5.5	4.75	5	5.25	V
V _{IH} High-level input voltage	2			2			V
V _{IL} Low-level input voltage			0.8			0.8	V
I _{OH} High-level output current			-2.4			-2.4	mA
I _{OL} Low-level output current			48			48	mA
T _A Operating free-air temperature	-55	125		0	70		°C

electrical characteristics over recommended operating free-air temperature range (unless otherwise noted)

PARAMETER	TEST CONDITIONS †	MIN	TYP ‡	MAX	UNIT
V _{IK}	V _{CC} = MIN, I _I = -12mA			-1.5	V
V _{OH}	V _{CC} = MIN, V _{IL} = 0.8 V, I _{OH} = -2.4 mA	2.4	3.4		V
V _{OL}	V _{CC} = MIN, V _{IH} = 2 V, I _{OL} = 48 mA		0.2	0.4	V
I _I	V _{CC} = MAX, V _I = 5.5 V			1	mA
I _{IH}	V _{CC} = MAX, V _I = 2.4 V			40	µA
I _{IL}	V _{CC} = MAX, V _I = 0.4 V			-1.6	mA
I _{OS} §	V _{CC} = MAX	-70		-180	mA
I _{CCH}	V _{CC} = MAX, V _I = 0 V		12	21	mA
I _{CCL}	V _{CC} = MAX, See Note 2		33	57	mA

† For conditions shown as MIN or MAX, use the appropriate value specified under recommended operating conditions.

‡ All typical values are at V_{CC} = 5 V, T_A = 25°C.

§ Not more than one output should be shorted at a time and the duration of the short circuit should not exceed one second.

NOTE 2: One input at 4.5 V, all others at GND.

switching characteristics, V_{CC} = 5 V, T_A = 25°C (see note 3)

PARAMETER	FROM (INPUT)	TO (OUTPUT)	TEST CONDITIONS	MIN	TYP	MAX	UNIT
t _{PLH}	A or B	Y	R _L = 133 Ω, C _L = 50 pF		6	9	ns
t _{PHL}					8	12	ns
t _{PLH}			R _L = 133 Ω, C _L = 150 pF		10	15	ns
t _{PHL}					12	18	ns

NOTE 3: See General Information Section for load circuits and voltage waveforms.

3

TTL DEVICES

TYPES SN54LS28, SN74LS28 QUADRUPLE 2-INPUT POSITIVE-NOR BUFFERS

recommended operating conditions

	SN54LS28			SN74LS28			UNIT		
	MIN	NOM	MAX	MIN	NOM	MAX			
V_{CC} Supply voltage	4.5	5	5.5	4.75	5	5.25	V		
V_{IH} High-level input voltage	2			2			V		
V_{IL} Low-level input voltage	0.7			0.8			V		
I_{OH} High-level output current	-1.2			-1.2			mA		
I_{OL} Low-level output current	12			24			mA		
T_A Operating free-air temperature	-55			125			0	70	°C

electrical characteristics over recommended operating free-air temperature range (unless otherwise noted)

PARAMETER	TEST CONDITIONS †	SN54LS28			SN74LS28			UNIT
		MIN	TYP‡	MAX	MIN	TYP‡	MAX	
V_{IK}	$V_{CC} = \text{MIN}, I_I = -18 \text{ mA}$	-1.5			-1.5			V
V_{OH}	$V_{CC} = \text{MIN}, V_{IL} = \text{MAX}, I_{OH} = -1.2 \text{ mA}$	2.5	3.4		2.7	3.4		V
V_{OL}	$V_{CC} = \text{MIN}, V_{IH} = 2 \text{ V}, I_{OL} = 12 \text{ mA}$	0.25	0.4		0.24	0.4		V
	$V_{CC} = \text{MIN}, V_{IH} = 2 \text{ V}, I_{OL} = 24 \text{ mA}$				0.35	0.5		
I_I	$V_{CC} = \text{MAX}, V_I = 7 \text{ V}$	0.1			0.1			mA
I_{IH}	$V_{CC} = \text{MAX}, V_I = 2.7 \text{ V}$	20			20			µA
I_{IL}	$V_{CC} = \text{MAX}, V_I = 0.4 \text{ V}$	-0.4			-0.4			mA
$I_{OS} §$	$V_{CC} = \text{MAX}$	-30	-130		-30	-130		mA
I_{CCH}	$V_{CC} = \text{MAX}, V_I = 0 \text{ V}$	1.8	3.6		1.8	3.6		mA
I_{CCL}	$V_{CC} = \text{MAX},$ See Note 2	6.9	13.8		6.9	13.8		mA

† For conditions shown as MIN or MAX, use the appropriate value specified under recommended operating conditions.

‡ All typical values are at $V_{CC} = 5 \text{ V}, T_A = 25^\circ\text{C}$.

§ Not more than one output should be shorted at a time and the duration of the short circuit should not exceed one second.

NOTE 2: One input at 4.5 V, all others at GND.

switching characteristics, $V_{CC} = 5 \text{ V}, T_A = 25^\circ\text{C}$ (see note 3)

PARAMETER	FROM (INPUT)	TO (OUTPUT)	TEST CONDITIONS	MIN	TYP	MAX	UNIT
t_{PLH}	A or B	Y	$R_L = 667 \Omega, C_L = 45 \text{ pF}$	12	24		ns
t_{PHL}				12	24		ns

NOTE 3: See General Information Section for load circuits and voltage waveforms.

3

TTL DEVICES

TYPES SN5430, SN54H30, SN54L30, SN54LS30, SN54S30, SN7430, SN74H30, SN74LS30, SN74S30 8-INPUT POSITIVE-NAND GATES

REVISED DECEMBER 1983

- Package Options Include Both Plastic and Ceramic Chip Carriers in Addition to Plastic and Ceramic DIPs
- Dependable Texas Instruments Quality and Reliability

description

These devices contain a single 8-input NAND gate.

The SN5430, SN54H30, SN54L30, SN54LS30, and SN54S30 are characterized for operation over the full military range of -55°C to 125°C . The SN7430, SN74H30, SN74LS30, and SN74S30 are characterized for operation from 0°C to 70°C .

FUNCTION TABLE

INPUTS A THRU H	OUTPUT Y
All inputs H	L
One or more inputs L	H

logic diagram

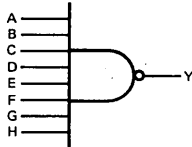

positive logic

$$Y = \overline{A \cdot B \cdot C \cdot D \cdot E \cdot F \cdot G \cdot H} \quad \text{or}$$

$$Y = \overline{A} + \overline{B} + \overline{C} + \overline{D} + \overline{E} + \overline{F} + \overline{G} + \overline{H}$$

SN5430, SN54H30, SN54L30 ... J PACKAGE
SN54LS30, SN54S30 ... J OR W PACKAGE
SN7430, SN74H30 ... J OR N PACKAGE
SN74LS30, SN74S30 ... D, J OR N PACKAGE

(TOP VIEW)

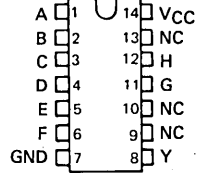

SN5430, SN54H30 ... W PACKAGE

(TOP VIEW)

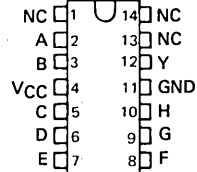

SN54LS30, SN54S30 ... FK PACKAGE
SN74LS30, SN74S30 ... FN PACKAGE

(TOP VIEW)

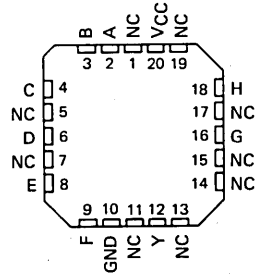

NC - No internal connection

PRODUCTION DATA
This document contains information current as of publication date. Products conform to specifications per the terms of Texas Instruments standard warranty. Production processing does not necessarily include testing of all parameters.



POST OFFICE BOX 225012 • DALLAS, TEXAS 75265

TYPES SN5430, SN54H30, SN54L30,
SN7430, SN74H30
8-INPUT POSITIVE-NAND GATES

schematics (each gate)

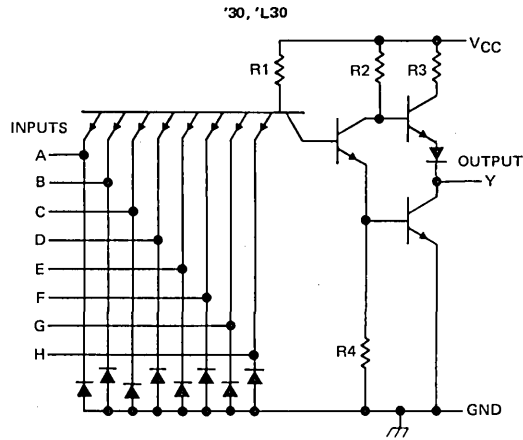

CIRCUIT	R1	R2	R3	R4
'30	4 k Ω	1.6 k Ω	130 Ω	1 k Ω
'L30	40 k Ω	20 k Ω	500 Ω	12 k Ω

Input clamp diodes not on SN54L30 circuit.

3

TTL DEVICES

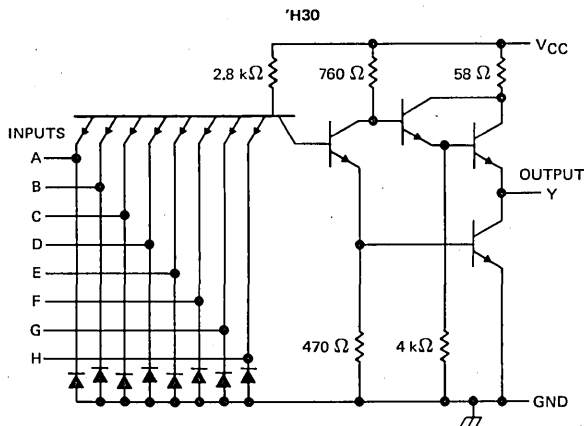

Resistor values shown are nominal.

TYPES SN5430, SN54H30, SN54L30, SN54LS30, SN54S30,
SN7430, SN74H30, SN74L30, SN74LS30, SN74S30
8-INPUT POSITIVE-NAND GATES

schematics (each gate)

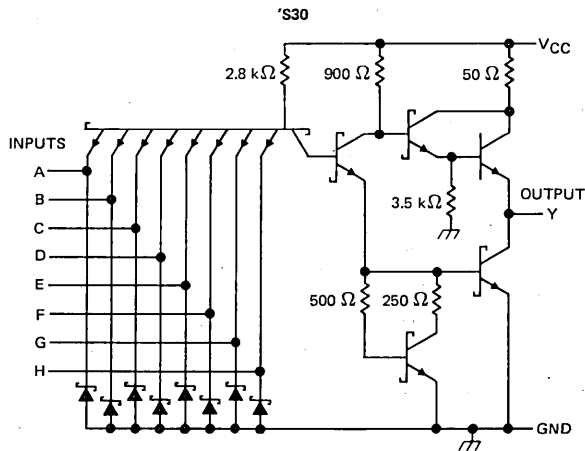
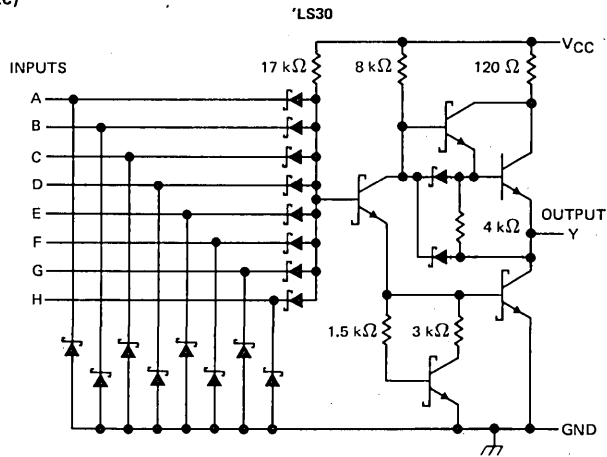

Resistor values shown are nominal.

absolute maximum ratings over operating free-air temperature range (unless otherwise noted)

Supply voltage, V_{CC} (see Note 1): '30, 'H30, 'LS30, 'S30	7 V
'L30	8 V
Input voltage: '30, 'H30, 'L30, 'S30	5.5 V
'LS30	7 V
Operating free-air temperature: SN54'	-55°C to 125°C
SN74'	0°C to 70°C
Storage temperature range	-65°C to 150°C

NOTE 1: Voltage values are with respect to network ground terminal.

TYPES SN5430, SN7430

8-INPUT POSITIVE-NAND GATES

recommended operating conditions

	SN5430			SN7430			UNIT
	MIN	NOM	MAX	MIN	NOM	MAX	
V _{CC} Supply voltage	4.5	5	5.5	4.75	5	5.25	V
V _{IH} High-level input voltage	2			2			V
V _{IL} Low-level input voltage			0.8			0.8	V
I _{OH} High-level output current			-0.4			-0.4	mA
I _{OL} Low-level output current			16			16	mA
T _A Operating free-air temperature	-55		125	0		70	°C

electrical characteristics over recommended operating free-air temperature range (unless otherwise noted)

PARAMETER	TEST CONDITIONS †	SN5430			SN7430			UNIT
		MIN	TYP ‡	MAX	MIN	TYP ‡	MAX	
V _{IK}	V _{CC} = MIN, I _I = -12 mA			-1.5			-1.5	V
V _{OH}	V _{CC} = MIN, V _{IL} = 0.8 V, I _{OH} = -0.4 mA	2.4	3.4		2.4	3.4		V
V _{OL}	V _{CC} = MIN, V _{IH} = 2 V, I _{OL} = 16 mA		0.2	0.4		0.2	0.4	V
I _I	V _{CC} = MAX, V _I = 5.5 V			1			1	mA
I _{IH}	V _{CC} = MAX, V _I = 2.4 V			40			40	μA
I _{IL}	V _{CC} = MAX, V _I = 0.4 V			-1.6			-1.6	mA
I _{OS} §	V _{CC} = MAX	-20		-55	-18		-55	mA
I _{CCH}	V _{CC} = MAX, V _I = 0 V		1	2		1	2	mA
I _{CCL}	V _{CC} = MAX, V _I = 4.5 V		3	6		3	6	mA

† For conditions shown as MIN or MAX, use the appropriate value specified under recommended operating conditions.

‡ All typical values are at V_{CC} = 5 V, T_A = 25°C.

§ Not more than one output should be shorted at a time.

switching characteristics, V_{CC} = 5 V, T_A = 25°C (see note 2)

PARAMETER	FROM (INPUT)	TO (OUTPUT)	TEST CONDITIONS	MIN	TYP	MAX	UNIT
t _{PLH}	Any	Y	R _L = 400 Ω, C _L = 15 pF		13	22	ns
t _{PHL}					8	15	ns

NOTE 2: See General Information Section for load circuits and voltage waveforms.

3

TTL DEVICES

TYPES SN54H30, SN74H30 8-INPUT POSITIVE-NAND GATES

recommended operating conditions

	SN54H30			SN74H30			UNIT
	MIN	NOM	MAX	MIN	NOM	MAX	
V _{CC} Supply voltage	4.5	5	5.5	4.75	5	5.25	V
V _{IH} High-level input voltage	2			2			V
V _{IL} Low-level input voltage	0.8			0.8			V
I _{OH} High-level output current	-0.5			-0.5			mA
I _{OL} Low-level output current	20			20			mA
T _A Operating free-air temperature	-55			125			°C

electrical characteristics over recommended operating free-air temperature range (unless otherwise noted)

PARAMETER	TEST CONDITIONS †	MIN	TYP ‡	MAX	UNIT
V _{IK}	V _{CC} = MIN, I _I = -8 mA	-1.5			V
V _{OH}	V _{CC} = MIN, V _{IL} = 0.8 V, I _{OH} = -0.5 mA	2.4	3.5		V
V _{OL}	V _{CC} = MIN, V _{IH} = 2 V, I _{OL} = 20 mA	0.2		0.4	V
I _I	V _{CC} = MAX, V _I = 5.5 V	1			mA
I _{IH}	V _{CC} = MAX, V _I = 2.4 V	50			μA
I _{IL}	V _{CC} = MAX, V _I = 0.4 V	-2			mA
I _{OS} §	V _{CC} = MAX	-40		-100	mA
I _{CCH}	V _{CC} = MAX, V _I = 0 V	2.5		4.2	mA
I _{CCL}	V _{CC} = MAX, V _I = 4.5 V	6.5		10	mA

† For conditions shown as MIN or MAX, use the appropriate value specified under recommended operating conditions.

‡ All typical values are at V_{CC} = 5 V, T_A = 25°C.

§ Not more than one output should be shorted at a time, and the duration of the short-circuit should not exceed one second.

switching characteristics, V_{CC} = 5 V, T_A = 25°C (see note 2)

PARAMETER	FROM (INPUT)	TO (OUTPUT)	TEST CONDITIONS	MIN	TYP	MAX	UNIT
t _{PLH}	Any	Y	R _L = 280 Ω, C _L = 25 pF	6.8		10	ns
t _{PHL}				8.9		12	ns

NOTE 2: See General Information Section for load circuits and voltage waveforms.

3

TTL DEVICES

TYPE SN54L30

8-INPUT POSITIVE-NAND GATES

recommended operating conditions

	SN54L30			UNIT
	MIN	NOM	MAX	
V _{CC} Supply voltage	4.5	5	5.5	V
V _{IH} High-level input voltage	2			V
V _{IL} Low-level input voltage			0.7	V
I _{OH} High-level output current			-0.1	mA
I _{OL} Low-level output current			2	mA
T _A Operating free-air temperature	-55	125		°C

electrical characteristics over recommended operating free-air temperature range (unless otherwise noted)

PARAMETER	TEST CONDITIONS †	SN54L30			UNIT
		MIN	TYP ‡	MAX	
V _{OH}	V _{CC} = MIN, V _{IL} = 0.7 V, I _{OH} = -0.1 mA	2.4	3.3		V
V _{OL}	V _{CC} = MIN, V _{IH} = 2 V, I _{OL} = 2 mA	0.15	0.3		V
I _I	V _{CC} = MAX, V _I = 5.5 V			0.1	mA
I _{IH}	V _{CC} = MAX, V _I = 2.4 V			10	μA
I _{IL}	V _{CC} = MAX, V _I = 0.3 V			-0.18	mA
I _{OS} §	V _{CC} = MAX	-3		-15	mA
I _{CCH}	V _{CC} = MAX, V _I = 0 V	0.11	0.33		mA
I _{CCL}	V _{CC} = MAX, V _I = 4.5 V	0.29	0.51		mA

† For conditions shown as MIN or MAX, use the appropriate value specified under recommended operating conditions.

‡ All typical values are at V_{CC} = 5 V, T_A = 25°C.

§ Not more than one output should be shorted at a time.

switching characteristics, V_{CC} = 5 V, T_A = 25°C (see note 2)

PARAMETER	FROM (INPUT)	TO (OUTPUT)	TEST CONDITIONS	MIN	TYP	MAX	UNIT
t _{PLH}	Any	Y	R _L = 4 kΩ, C _L = 50 pF		35	60	ns
t _{PHL}					70	100	ns

NOTE 2: See General Information Section for load circuits and voltage waveforms.

TYPES SN54LS30, SN74LS30 8-INPUT POSITIVE-NAND GATES

recommended operating conditions

	SN54LS30			SN74LS30			UNIT
	MIN	NOM	MAX	MIN	NOM	MAX	
V _{CC} Supply voltage	4.5	5	5.5	4.75	5	5.25	V
V _{IH} High-level input voltage	2			2			V
V _{IL} Low-level input voltage			0.7			0.8	V
I _{OH} High-level output current			-0.4			-0.4	mA
I _{OL} Low-level output current			4			8	mA
T _A Operating free-air temperature	-55		125	0		70	°C

electrical characteristics over recommended operating free-air temperature range (unless otherwise noted)

PARAMETER	TEST CONDITIONS †	SN54LS30			SN74LS30			UNIT
		MIN	TYP‡	MAX	MIN	TYP‡	MAX	
V _{IK}	V _{CC} = MIN, I _I = -18 mA			-1.5			-1.5	V
V _{OH}	V _{CC} = MIN, V _{IL} = MAX, I _{OH} = -0.4 mA	2.5	3.4		2.7	3.4		V
V _{OL}	V _{CC} = MIN, V _{IH} = 2 V, I _{OL} = 4 mA		0.25	0.4			0.4	V
	V _{CC} = MIN, V _{IH} = 2 V, I _{OL} = 8 mA					0.25	0.5	
I _I	V _{CC} = MAX, V _I = 7 V			0.1			0.1	mA
I _{IH}	V _{CC} = MAX, V _I = 2.7 V			20			20	μA
I _{IL}	V _{CC} = MAX, V _I = 0.4 V			-0.4			-0.4	mA
I _{OS} §	V _{CC} = MAX	-20		-100	-20		-100	mA
I _{CCH}	V _{CC} = MAX, V _I = 0 V		0.35	0.5		0.35	0.5	mA
I _{CCL}	V _{CC} = MAX, V _I = 4.5 V		0.6	1.1		0.6	1.1	mA

† For conditions shown as MIN or MAX, use the appropriate value specified under recommended operating conditions.

‡ All typical values are at V_{CC} = 5 V, T_A = 25°C

§ Not more than one output should be shorted at a time, and the duration of the short-circuit should not exceed one second.

switching characteristics, V_{CC} = 5 V, T_A = 25°C (see note 2)

PARAMETER	FROM (INPUT)	TO (OUTPUT)	TEST CONDITIONS		MIN	TYP	MAX	UNIT
t _{PLH}	Any	Y	R _L = 2 kΩ,	C _L = 15 pF		8	15	ns
t _{PHL}						13	20	ns

NOTE 2: See General Information Section for load circuits and voltage waveforms.

3
TTL DEVICES

TYPES SN54S30, SN74S30

8-INPUT POSITIVE-NAND GATES

recommended operating conditions

	SN54S30			SN74S30			UNIT
	MIN	NOM	MAX	MIN	NOM	MAX	
V _{CC} Supply voltage	4.5	5	5.5	4.75	5	5.25	V
V _{IH} High-level input voltage	2			2			V
V _{IL} Low-level input voltage			0.8			0.8	V
I _{OH} High-level output current			-1			-1	mA
I _{OL} Low-level output current			20			20	mA
T _A Operating free-air temperature	-55		125	0		70	°C

electrical characteristics over recommended operating free-air temperature range (unless otherwise noted)

PARAMETER	TEST CONDITIONS †	SN54S30			SN74S30			UNIT
		MIN	TYP‡	MAX	MIN	TYP‡	MAX	
V _{IK}	V _{CC} = MIN, I _I = -18 mA			-1.2			-1.2	V
V _{OH}	V _{CC} = MIN, V _{IL} = 0.8 V, I _{OH} = -1 mA	2.5	3.4		2.7	3.4		V
V _{OL}	V _{CC} = MIN, V _{IH} = 2 V, I _{OL} = 20 mA			0.5			0.5	V
I _I	V _{CC} = MAX, V _I = 5.5 V			1			1	mA
I _{IH}	V _{CC} = MAX, V _I = 2.7 V			50			50	μA
I _{IL}	V _{CC} = MAX, V _I = 0.5 V			-2			-2	mA
I _{OS} §	V _{CC} = MAX	-40		-100	-40		-100	mA
I _{CCH}	V _{CC} = MAX, V _I = 0 V		3	5		3	5	mA
I _{CCL}	V _{CC} = MAX, V _I = 4.5 V		5.5	10		5.5	10	mA

† For conditions shown as MIN or MAX, use the appropriate value specified under recommended operating conditions.

‡ All typical values are at V_{CC} = 5 V, T_A = 25°C.

§ Not more than one output should be shorted at a time, and the duration of the short-circuit should not exceed one second.

switching characteristics, V_{CC} = 5 V, T_A = 25°C (see note 2)

PARAMETER	FROM (INPUT)	TO (OUTPUT)	TEST CONDITIONS	MIN	TYP	MAX	UNIT
t _{PLH}	Any	Y	R _L = 280 Ω, C _L = 15 pF		4	6	ns
t _{PHL}					4.5	7	ns
t _{PLH}			R _L = 280 Ω, C _L = 50 pF		5.5		ns
t _{PHL}					6.5		ns

NOTE 2: See General Information Section for load circuits and voltage waveforms.

TYPES SN54LS31, SN74LS31 DELAY ELEMENTS

REVISED DECEMBER 1983

- Delay Elements for Generating Delay Lines
- Inverting and Non-inverting Elements
- Buffer NAND Elements Rated at I_{OL} of 12/24 mA
- PNP Inputs Reduce Fan-In ($I_{IL} = -0.2$ mA MAX)
- Worst Case MIN/MAX Delays Guaranteed Across Temperature and V_{CC} Ranges

description

These 'LS31 delay elements are intended to provide well-defined delays across both temperature and V_{CC} ranges. Used in cascade, a limitless range of delay gating is possible.

All inputs are PNP with I_{IL} MAX of -0.2 mA. Gates 1, 2, 5, and 6 have standard Low-Power Schottky output sink current capability of 4 and 8 mA I_{OL} . Buffers 3 and 4 are rated at 12 and 24 mA.

The SN54LS31 is characterized for operation over the full military temperature range of -55°C to 125°C . The SN74LS31 is characterized for operation from 0°C to 70°C .

logic symbol†

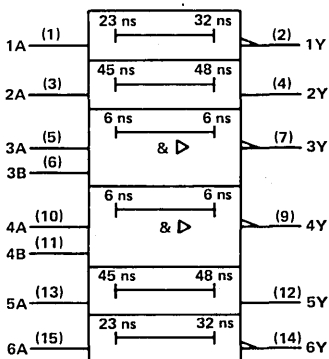

†Pin numbers shown on logic notation are for D, J and N packages only.

SN54LS31 ... J OR W PACKAGE
SN74LS31 ... D, J OR N PACKAGE
(TOP VIEW)

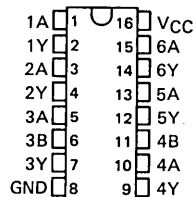

SN54LS31 ... FK PACKAGE
SN74LS31 ... FN PACKAGE
(TOP VIEW)

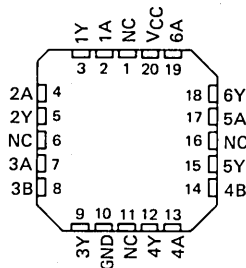

NC - No internal connection

3

TTL DEVICES

PRODUCTION DATA
This document contains information current as of publication date. Products conform to specifications per the terms of Texas Instruments standard warranty. Production processing does not necessarily include testing of all parameters.

TEXAS INSTRUMENTS
POST OFFICE BOX 225012 • DALLAS, TEXAS 75265

TYPES SN54LS31, SN74LS31 DELAY ELEMENTS

Delay Element	Logic	Typical Delays			Rated I _{OL}
		t _{PLH}	t _{PHL}	AVG.	
Gates 1 and 6	Inverting	32 ns	23 ns	27.5 ns	4 and 8 mA
Gates 2 and 5	Non-Inverting	45 ns	48 ns	46.5 ns	4 and 8 mA
Buffers 3 and 4	2-Input NAND	6 ns	6 ns	6 ns	12 and 24 mA

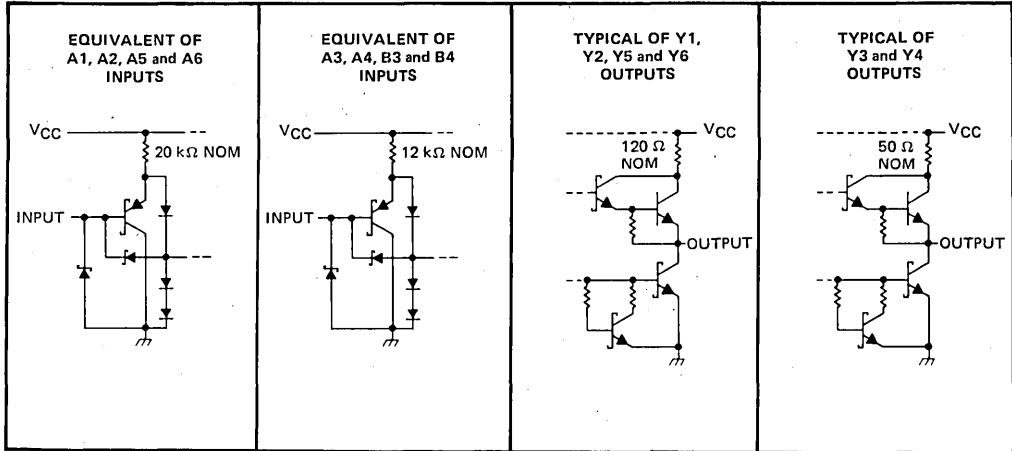

3 TTL DEVICES

absolute maximum ratings over operating free air temperature range (unless otherwise noted)

Supply voltage, V _{CC} (See Note 1)	7 V
Input voltage, V _I : All inputs	7 V
Operating free-air temperature range: SN54LS31	-55°C to 125°C
SN74LS31	0°C to 70°C
Storage temperature range	-65°C to 150°C

NOTE 1: Voltage values are with respect to network ground terminal.

recommended operating conditions

	SN54LS31			SN74LS31			UNIT
	MIN	NOM	MAX	MIN	NOM	MAX	
V _{CC} Supply voltage	4.5	5	5.5	4.75	5	5.25	V
V _{IH} High-level input voltage	2						V
V _{IL} Low-level input voltage	0.7						V
I _{OH} High-level output current	Y3, Y4 outputs			-1.2			mA
	All other outputs			-0.4			
I _{OL} Low-level output current	Y3, Y4 outputs			12			mA
	All other outputs			4			
T _A Operating free-air temperature	-55		125	0		70	°C

electrical characteristics over recommended operating free-air temperature range (unless otherwise noted)

PARAMETER	TEST CONDITIONS†			SN54LS31			SN74LS31			UNIT
				MIN	TYP‡	MAX	MIN	TYP‡	MAX	
V _{IK}	V _{CC} = MIN, I _I = -18 mA			-1.5			-1.5			V
V _{OH}	V _{CC} = MIN, V _{IH} = 2 V, V _{IL} = MAX	Y3, Y4	I _{OH} = -1.2 mA	2.4	3.1		2.4	3.1	V	
		Others	I _{OH} = -0.4 mA	2.5	3.1		2.7	3.1		
V _{OL}	V _{CC} = MIN, V _{IH} = 2 V, V _{IL} = MAX	Y3, Y4	I _{OL} = 12 mA	0.25	0.4		0.25	0.4	V	
			I _{OL} = 24 mA				0.35	0.5		
		Others	I _{OL} = 4 mA	0.25	0.4		0.25	0.4		
			I _{OL} = 8 mA				0.35	0.5		
I _I	V _{CC} = MAX, V _I = 7 V			0.1			0.1			mA
I _{IH}	V _{CC} = MAX, V _I = 2.7 V			20			20			μA
I _{IL}	V _{CC} = MAX, V _I = 0.4 V			-0.2			-0.2			mA
I _{OS} §	V _{CC} = MAX, A3, A4, B3, B4 = 0 V		Y3, Y4	-30	-130		-30	-130	mA	
	V _{CC} = MAX, A1, A6 = 0 V, A2, A5 = 4.5 V		Y1, Y2, Y5, Y6	-20	-100		-20	-100		
I _{CC}	I _{CCH}	V _{CC} = MAX, A2, A5 = 4.5 V, all other inputs 0 V			2.3	4		2.3	4	mA
	I _{CCL}	V _{CC} = MAX, A2, A5 = 0 V, all other inputs 4.5 V			13	20		13	20	

† For conditions shown as MIN or MAX, use the appropriate value specified under recommended operating conditions.

‡ All typical values are at V_{CC} = 5 V, T_A = 25°C.

§ Not more than one output should be shorted at a time and the duration of the short-circuit should not exceed one second.

switching characteristics, (see note 2)

PARAMETER	FROM (INPUT)	TO (OUTPUT)	SN54LS31			SN74LS31			UNIT
			MIN	TYP	MAX	MIN	TYP	MAX	
t _{PLH}	A1, A6	Y1, Y6	15	70		22	65	ns	
t _{PHL}			9	50		13	45	ns	
t _{PLH}	A2, A5	Y2, Y5	22	90		31	80	ns	
t _{PHL}			20	105		30	95	ns	
t _{PLH}	A3, B3, A4, Y4	Y3, Y4	2	20		2	15	ns	
t _{PHL}			2	20		2	15	ns	

NOTE 2: V_{CC} = MIN to MAX

R_L = 667 Ω, C_L = 45 pF for Y3 and Y4.

R_L = 2 kΩ, C_L = 15 pF for Y1, Y2, Y5 and Y6.

T_A = MIN to MAX

See General Information Section for load circuits and voltage waveforms.

3

TTL DEVICES

TYPES SN5432, SN54LS32, SN54S32, SN7432, SN74LS32, SN74S32 QUADRUPLE 2-INPUT POSITIVE-OR GATES

REVISED DECEMBER 1983

- Package Options Include Both Plastic and Ceramic Chip Carriers in Addition to Plastic and Ceramic DIPs
- Dependable Texas Instruments Quality and Reliability

description

These devices contain four independent 2-input OR gates.

The SN5432, SN54LS32 and SN54S32 are characterized for operation over the full military range of -55°C to 125°C . The SN7432, SN74LS32 and SN74S32 are characterized for operation from 0°C to 70°C .

FUNCTION TABLE (each gate)

INPUTS		OUTPUT
A	B	Y
H	X	H
X	H	H
L	L	L

logic diagram (each gate)



positive logic

$$Y = A + B \text{ or } Y = \overline{\overline{A} \cdot \overline{B}}$$

SN5432, SN54LS32, SN54S32 ... J OR W PACKAGE
SN7432 ... J OR N PACKAGE
SN74LS32, SN74S32 ... D, J or N PACKAGE

(TOP VIEW)

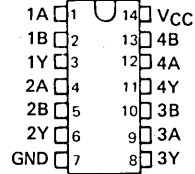

SN54LS32, SN54S32 ... FK PACKAGE
SN74LS32, SN74S32 ... FN PACKAGE

(TOP VIEW)

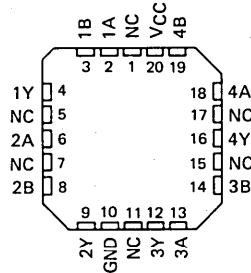

NC - No internal connection

3

TTL DEVICES

PRODUCTION DATA

This document contains information current as of publication date. Products conform to specifications per the terms of Texas Instruments standard warranty. Production processing does not necessarily include testing of all parameters.

TEXAS
INSTRUMENTS

POST OFFICE BOX 225012 • DALLAS, TEXAS 75265

3-151

**TYPES SN5432, SN54LS32, SN54S32,
SN7432, SN74LS32, SN74S32
QUADRUPLE 2-INPUT POSITIVE-OR GATES**

schematics (each gate)

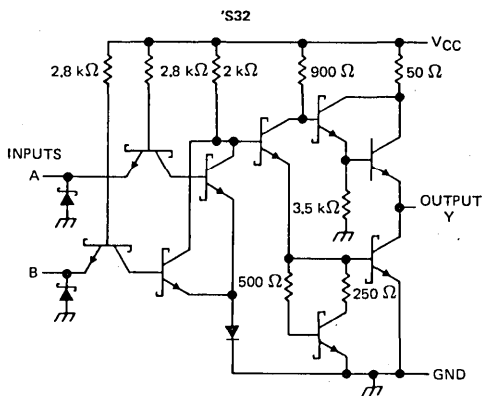
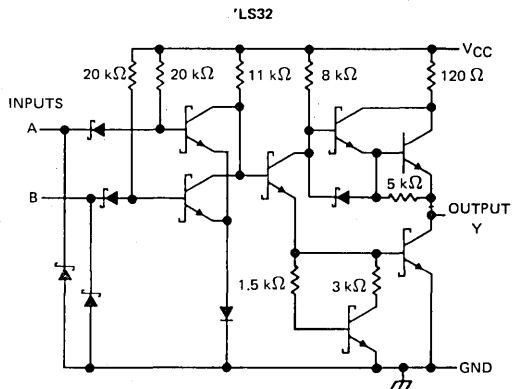
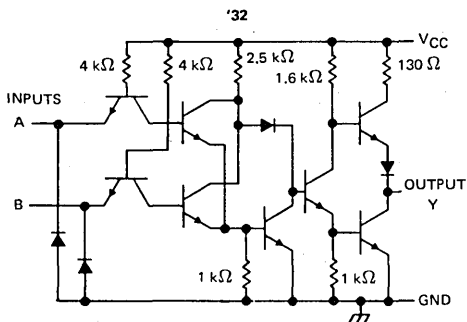

Resistor values shown are nominal.

absolute maximum ratings over operating free-air temperature range (unless otherwise noted)

Supply voltage, V_{CC} (see Note 1)	7 V
Input voltage: '32, 'S32	5.5 V
'LS32	7 V
Operating free-air temperature: SN54'	-55°C to 125°C
SN74'	0°C to 70°C
Storage temperature range	-65°C to 150°C

NOTE 1: Voltage values are with respect to network ground terminal.

TYPES SN5432, SN7432

QUADRUPLE 2-INPUT POSITIVE-OR GATES

recommended operating conditions

	SN5432			SN7432			UNIT
	MIN	NOM	MAX	MIN	NOM	MAX	
V _{CC} Supply voltage	4.5	5	5.5	4.75	5	5.25	V
V _{IH} Hgh-level input voltage	2			2			V
V _{IL} Low-level input voltage			0.8			0.8	V
I _{OH} High-level output current			-0.8			-0.8	mA
I _{OL} Low-level output current			16			16	mA
T _A Operating free-air temperature	-55		125	0		70	°C

electrical characteristics over recommended operating free-air temperature range (unless otherwise noted)

PARAMETER	TEST CONDITIONS†	SN5432			SN7432			UNIT
		MIN	TYP‡	MAX	MIN	TYP‡	MAX	
V _{IK}	V _{CC} = MIN, I _I = -12 mA		-1.5			-1.5	V	
V _{OH}	V _{CC} = MIN, V _{IH} = 2 V, I _{OH} = -0.8 mA	2.4	3.4		2.4	3.4	V	
V _{OL}	V _{CC} = MIN, V _{IL} = 0.8 V, I _{OL} = 16 mA		0.2	0.4		0.2	0.4	V
I _I	V _{CC} = MAX, V _I = 5.5 V			1			1	mA
I _{IH}	V _{CC} = MAX, V _I = 2.4 V			40			40	μA
I _{IL}	V _{CC} = MAX, V _I = 0.4 V			-1.6			-1.6	mA
I _{OS§}	V _{CC} = MAX	-20		-55	-18		-55	mA
I _{CCH}	V _{CC} = MAX, See Note 2		15	22		15	22	mA
I _{CCL}	V _{CC} = MAX, V _I = 0 V		23	38		23	38	mA

† For conditions shown as MIN or MAX, use the appropriate value specified under recommended operating conditions.

‡ All typical values are at V_{CC} = 5 V, T_A = 25°C.

§ Not more than one output should be shorted at a time.

NOTE 2: One input at 4.5 V, all others at GND.

switching characteristics, V_{CC} = 5 V, T_A = 25°C (see note 3)

PARAMETER	FROM (INPUT)	TO (OUTPUT)	TEST CONDITIONS	MIN	TYP	MAX	UNIT
t _{PLH}	A or B	Y	R _L = 400 Ω, C _L = 15 pF		10	15	ns
t _{PHL}					14	22	ns

NOTE 3: See General Information Section for load circuits and voltage waveforms.

3

TTL DEVICES

TYPES SN54LS32, SN74LS32 QUADRUPLE 2-INPUT POSITIVE-OR GATES

recommended operating conditions

	SN54LS32			SN74LS32			UNIT
	MIN	NOM	MAX	MIN	NOM	MAX	
V _{CC} Supply voltage	4.5	5	5.5	4.75	5	5.25	V
V _{IH} High-level input voltage	2			2			V
V _{IL} Low-level input voltage			0.7			0.8	V
I _{OH} High-level output current			-0.4			-0.4	mA
I _{OL} Low-level output current			4			8	mA
T _A Operating free-air temperature	-55		125	0		70	°C

electrical characteristics over recommended operating free-air temperature range (unless otherwise noted)

PARAMETER	TEST CONDITIONS †	SN54LS32			SN74LS32			UNIT
		MIN	TYP ‡	MAX	MIN	TYP ‡	MAX	
V _{IK}	V _{CC} = MIN, I _I = -18 mA		-1.5			-1.5	V	
V _{OH}	V _{CC} = MIN, V _{IH} = 2 V, I _{OH} = -0.4 mA	2.5	3.4		2.7	3.4	V	
V _{OL}	V _{CC} = MIN, V _{IL} = MAX, I _{OL} = 4 mA		0.25	0.4		0.25	0.4	V
	V _{CC} = MIN, V _{IL} = MAX, I _{OL} = 8 mA					0.35	0.5	
I _I	V _{CC} = MAX, V _I = 7 V			0.1			0.1	mA
I _{IH}	V _{CC} = MAX, V _I = 2.7 V			20			20	μA
I _{IL}	V _{CC} = MAX, V _I = 0.4 V			-0.4			-0.4	mA
I _{OS} §	V _{CC} = MAX	-20		-100	-20		-100	mA
I _{CCH}	V _{CC} = MAX, See Note 2		3.1	6.2		3.1	6.2	mA
I _{CCL}	V _{CC} = MAX, V _I = 0 V		4.9	9.8		4.9	9.8	mA

† For conditions shown as MIN or MAX, use the appropriate value specified under recommended operating conditions.

‡ All typical values are at V_{CC} = 5 V, T_A = 25°C.

§ Not more than one output should be shorted at a time and the duration of the short-circuit should not exceed one second.

NOTE 2: One input at 4.5 V, all others at GND.

switching characteristics, V_{CC} = 5 V, T_A = 25°C (see note 3)

PARAMETER	FROM (INPUT)	TO (OUTPUT)	TEST CONDITIONS	MIN	TYP	MAX	UNIT
t _{PLH}	A or B	Y	R _L = 2 kΩ, C _L = 15 pF		14	22	ns
t _{PHL}					14	22	ns

NOTE 3: See General Information Section for load circuits and voltage waveforms.

3

TTL DEVICES

TYPES SN54S32, SN74S32 QUADRUPLE 2-INPUT POSITIVE-OR GATES

recommended operating conditions

	SN54S32			SN74S32			UNIT
	MIN	NOM	MAX	MIN	NOM	MAX	
V _{CC} Supply voltage	4.5	5	5.5	4.75	5	5.25	V
V _{IH} High-level input voltage	2			2			V
V _{IL} Low-level input voltage	0.8			0.8			V
I _{OH} High-level output current	-1			-1			mA
I _{OL} Low-level output current	20			20			mA
T _A Operating free-air temperature	-55	125		0	70		°C

electrical characteristics over recommended operating free-air temperature range (unless otherwise noted)

PARAMETER	TEST CONDITIONS †	SN54S32			SN74S32			UNIT
		MIN	TYP ‡	MAX	MIN	TYP ‡	MAX	
V _{IK}	V _{CC} = MIN, I _I = -18 mA	-1.2			-1.2			V
V _{OH}	V _{CC} = MIN, V _{IH} = 2 V, I _{OH} = -1 mA	2.5	3.4		2.7	3.4	V	
V _{OL}	V _{CC} = MIN, V _{IL} = 0.8 V, I _{OL} = 20 mA	0.5			0.5			V
I _I	V _{CC} = MAX, V _I = 5.5 V	1			1			mA
I _{IH}	V _{CC} = MAX, V _I = 2.7 V	50			50			μA
I _{IL}	V _{CC} = MAX, V _I = 0.5 V	-2			-2			mA
I _{OS} §	V _{CC} = MAX	-40	-100		-40	-100		mA
I _{CCH}	V _{CC} = MAX, See Note 2	18 32		18 32		mA		
I _{CCL}	V _{CC} = MAX, V _I = 0 V	38 68		38 68		mA		

† For conditions shown as MIN or MAX, use the appropriate value specified under recommended operating conditions.

‡ All typical values are at V_{CC} = 5 V, T_A = 25°C.

§ Not more than one output should be shorted at a time and the duration of the short-circuit should not exceed one second.

NOTE 2: One input at 4.5 V, all others at GND.

switching characteristics, V_{CC} = 5 V, T_A = 25°C (see note 3)

PARAMETER	FROM (INPUT)	TO (OUTPUT)	TEST CONDITIONS	MIN	TYP	MAX	UNIT
t _{PLH}	A or B	Y	R _L = 280 Ω, C _L = 15 pF		4	7	ns
t _{PHL}					4	7	ns
t _{PLH}	A or B	Y	R _L = 280 Ω, C _L = 50 pF		5		ns
t _{PHL}					5		ns

NOTE 3: See General Information Section for load circuits and voltage waveforms.

3

TTL DEVICES

TYPES SN5433, SN54LS33, SN7433, SN74LS33 QUADRUPLE 2-INPUT POSITIVE-NOR BUFFERS WITH OPEN-COLLECTOR OUTPUTS

REVISED DECEMBER 1983

- Package Options Include Both Plastic and Ceramic Chip Carriers in Addition to Plastic and Ceramic DIPs
- Dependable Texas Instruments Quality and Reliability

description

These devices contain four independent 2-input NOR buffer gates with open-collector outputs. Open-collector outputs require resistive pull-up to perform logically but can deliver higher V_{OH} levels and are commonly used in wired-AND applications.

The SN5433, and SN54LS33 are characterized for operation over the full military temperature range of -55°C to 125°C . The SN7433, and SN74LS33 are characterized for operation from 0°C to 70°C .

FUNCTION TABLE (each gate)

INPUTS		OUTPUT
A	B	Y
H	X	L
X	H	L
L	L	H

logic diagram (each gate)



positive logic

$$Y = \overline{A + B} \text{ or } Y = \overline{A \cdot B}$$

SN5433, SN54LS33 ... J OR W PACKAGE
SN7433 ... J OR N PACKAGE
SN74LS33 ... D, J OR N PACKAGE
(TOP VIEW)

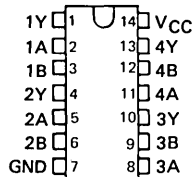

SN54LS33 ... FK PACKAGE
SN74LS33 ... FN PACKAGE
(TOP VIEW)

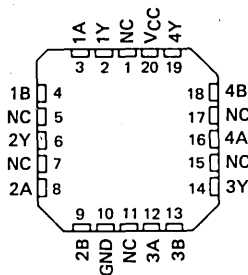

NC - No internal connection

3

TTL DEVICES

PRODUCTION DATA

This document contains information current as of publication date. Products conform to specifications per the terms of Texas Instruments standard warranty. Production processing does not necessarily include testing of all parameters.

3-156

TEXAS
INSTRUMENTS

POST OFFICE BOX 225012 • DALLAS, TEXAS 75265

TYPES SN5433, SN54LS33, SN7433, SN74LS33 QUADRUPLE 2-INPUT POSITIVE-NOR BUFFERS WITH OPEN-COLLECTOR OUTPUTS

schematics (each gate)

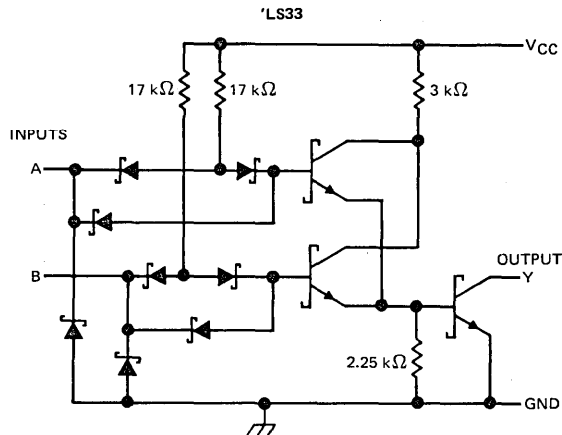
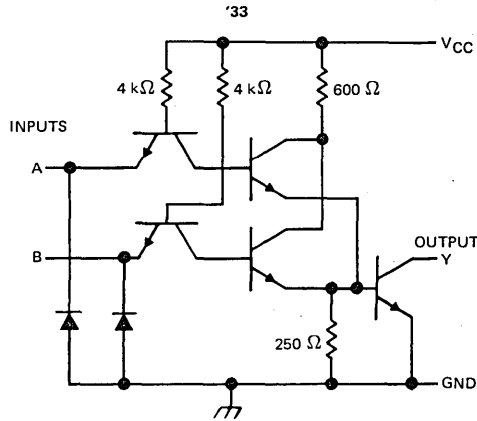

Resistor values shown are nominal.

absolute maximum ratings over operating free-air temperature (unless otherwise noted)

Supply voltage, V_{CC} (see Note 1)	7 V
Input voltage: '33	5.5 V
'LS33	7 V
Off-state output voltage	7 V
Operating free-air temperature: SN54'	-55°C to 125°C
SN74'	0°C to 70°C
Storage temperature range	-65°C to 150°C

NOTE 1: Voltage values are with respect to network ground terminal.

TYPES SN5433, SN7433 QUADRUPLE 2-INPUT POSITIVE-NOR BUFFERS WITH OPEN-COLLECTOR OUTPUTS

recommended operating conditions

	SN5433			SN7433			UNIT
	MIN	NOM	MAX	MIN	NOM	MAX	
V_{CC} Supply voltage	4.5	5	5.5	4.75	5	5.25	V
V_{IH} High-level input voltage	2			2			V
V_{IL} Low-level input voltage				0.8			V
V_{OH} High-level output voltage				5.5			V
I_{OL} Low-level output current				48			mA
T_A Operating free-air temperature	-55			125			°C

electrical characteristics over recommended operating free-air temperature range (unless otherwise noted)

PARAMETER	TEST CONDITIONS †	SN5433		SN7433		UNIT
		MIN	TYP ‡	MAX	MIN	
V_{IK}	$V_{CC} = \text{MIN}, I_I = -12 \text{ mA}$	-1.5		-1.5		V
I_{OH}	$V_{CC} = \text{MIN}, V_{IH} = 2 \text{ V}, V_{OH} = 5.5 \text{ V}$	0.25		0.25		mA
V_{OL}	$V_{CC} = \text{MIN}, V_{IL} = 0.8 \text{ V}, I_{OL} = 48 \text{ mA}$	0.4		0.4		V
I_I	$V_{CC} = \text{MAX}, V_I = 5.5 \text{ V}$	1		1		mA
I_{IH}	$V_{CC} = \text{MAX}, V_I = 2.4 \text{ V}$	40		40		μA
I_{IL}	$V_{CC} = \text{MAX}, V_I = 0.4 \text{ V}$	-1.6		-1.6		mA
I_{CCH}	$V_{CC} = \text{MAX}, V_I = 0 \text{ V}$	12	21	12	21	mA
I_{CCL}	$V_{CC} = \text{MAX},$ See Note 2	33	57	33	57	mA

† For conditions shown as MIN or MAX, use the appropriate value specified under recommended operating conditions.

‡ All typical values are at $V_{CC} = 5 \text{ V}, T_A = 25^\circ\text{C}$.

NOTE 2: One input at 4.5 V, all others at GND.

switching characteristics, $V_{CC} = 5 \text{ V}, T_A = 25^\circ\text{C}$ (see note 3)

PARAMETER	FROM (INPUT)	TO (OUTPUT)	TEST CONDITIONS	MIN	TYP	MAX	UNIT
t_{PLH}	A or B	Y	$R_L = 133 \Omega, C_L = 50 \text{ pF}$	10	15		ns
t_{PHL}				12	18		ns
t_{PLH}			$R_L = 133 \Omega, C_L = 150 \text{ pF}$	15	22		ns
t_{PHL}				16	24		ns

NOTE 3: See General Information Section for load circuits and voltage waveforms.

TYPES SN54LS33, SN74LS33

QUADRUPLE 2-INPUT POSITIVE-NOR BUFFERS WITH OPEN -COLLECTOR OUTPUTS

recommended operating conditions

	SN54LS33			SN74LS33			UNIT
	MIN	NOM	MAX	MIN	NOM	MAX	
V _{CC} Supply voltage	4.5	5	5.5	4.75	5	5.25	V
V _{IH} High-level input voltage	2			2			V
V _{IL} Low-level input voltage				0.7			V
V _{OH} High-level output voltage				5.5			V
I _{OL} Low-level output current				12			24 mA
T _A Operating free-air temperature	- 55			125			0 70 °C

electrical characteristics over recommended operating free-air temperature range (unless otherwise noted)

PARAMETER	TEST CONDITIONS †	SN54LS33			SN74LS33			UNIT
		MIN	TYP ‡	MAX	MIN	TYP ‡	MAX	
V _{IK}	V _{CC} = MIN, I _I = - 18 mA	- 1.5			- 1.5			V
I _{OH}	V _{CC} = MIN, V _{IH} = 2 V, V _{OH} = 5.5 V	0.25			0.25			mA
V _{OL}	V _{CC} = MIN, V _{IL} = MAX, I _{OL} = 12 mA	0.25	0.4		0.25	0.4	V	
	V _{CC} = MIN, V _{IL} = MAX, I _{OL} = 24 mA				0.35	0.5		
I _I	V _{CC} = MAX, V _I = 7 V	0.1			0.1			mA
I _{IH}	V _{CC} = MAX, V _I = 2.7 V	20			20			µA
I _{IL}	V _{CC} = MAX, V _I = 0.4 V	- 0.4			- 0.4			mA
I _{CCH}	V _{CC} = MAX, V _I = 0 V	1.8	3.6		1.8	3.6	mA	
I _{CCL}	V _{CC} = MAX, See Note 2	6.9	13.8		6.9	13.8	mA	

† For conditions shown as MIN or MAX, use the appropriate value specified under recommended operating conditions.

‡ All typical values are at V_{CC} = 5 V, T_A = 25°C.

NOTE 2: One input at 4.5 V, all others at GND.

switching characteristics, V_{CC} = 5 V, T_A = 25°C (see note 3)

PARAMETER	FROM (INPUT)	TO (OUTPUT)	TEST CONDITIONS	MIN	TYP	MAX	UNIT
t _{PLH}	A or B	Y	R _L = 667 Ω, C _L = 45 pF		20	32	ns
t _{PHL}					18	28	ns

NOTE 3: See General Information Section for load circuits and voltage waveforms.

3

TTL DEVICES

TYPES SN5437, SN54LS37, SN54S37, SN7437, SN74LS37, SN74S37 QUADRUPLE 2-INPUT POSITIVE-NAND BUFFERS

REVISED DECEMBER 1983

- Package Options Include Both Plastic and Ceramic Chip Carriers in Addition to Plastic and Ceramic DIPs
- Dependable Texas Instruments Quality and Reliability

description

These devices contain four independent 2-input NAND buffer gates.

The SN5437, SN54LS37 and SN54S37 are characterized for operation over the full military range of -55°C to 125°C . The SN7437, SN74LS37 and SN74S37 are characterized for operation from 0°C to 70°C .

FUNCTION TABLE (each gate)

INPUTS		OUTPUT
A	B	Y
H	H	L
L	X	H
X	L	H

logic diagram (each gate)



positive logic

$$Y = \overline{A \cdot B} \text{ or } Y = \overline{A} + \overline{B}$$

SN5437, SN54LS37, SN54S37 ... J OR W PACKAGE
SN7437 ... J OR N PACKAGE
SN74LS37, SN74S37 ... D, J OR N PACKAGE
(TOP VIEW)

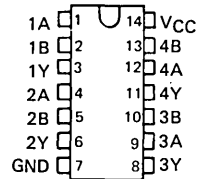

SN54LS37, SN54S37 ... FK PACKAGE
SN74LS37, SN74S37 ... FN PACKAGE
(TOP VIEW)

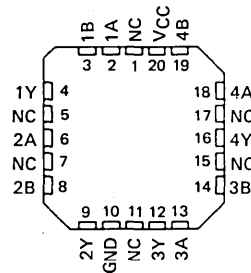

NC - No internal connection



TTL DEVICES

PRODUCTION DATA

This document contains information current as of publication date. Products conform to specifications per the terms of Texas Instruments standard warranty. Production processing does not necessarily include testing of all parameters.

TEXAS
INSTRUMENTS

POST OFFICE BOX 225012 • DALLAS, TEXAS 75265

TYPES SN5437, SN54LS37, SN54S37,
 SN7437, SN74LS37, SN74S37
 QUADRUPLE 2-INPUT POSITIVE-NAND BUFFERS

schematics (each gate)

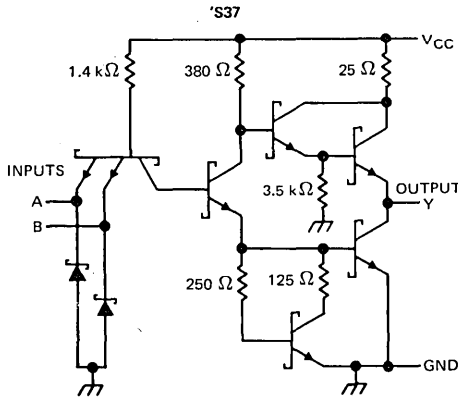
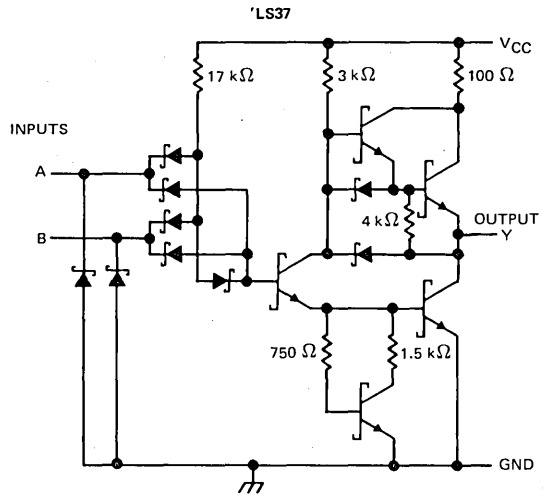
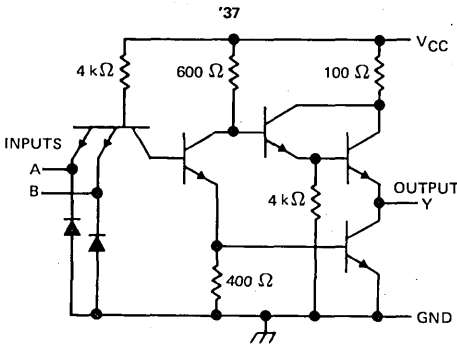

Resistor values shown are nominal.

absolute maximum ratings over operating free-air temperature range (unless otherwise noted)

Supply voltage, V_{CC} (see Note 1)	7 V
Input voltage: '37, 'S37	5.5 V
'LS37	7 V
Operating free-air temperature: SN54'	-55°C to 125°C
SN74'	0°C to 70°C
Storage temperature range	-65°C to 150°C

NOTE 1: Voltage values are with respect to network ground terminal.

TYPES SN5437, SN7437 QUADRUPLE 2-INPUT POSITIVE-NAND BUFFERS

recommended operating conditions

	SN5437			SN7437			UNIT	
	MIN	NOM	MAX	MIN	NOM	MAX		
V _{CC} Supply voltage	4.5	5	5.5	4.75	5	5.25	V	
V _{IH} High-level input voltage	2			2			V	
V _{IL} Low-level input voltage	0.8			0.8			V	
I _{OH} High-level output current	-1.2			-1.2			mA	
I _{OL} Low-level output current	48			48			mA	
T _A Operating free-air temperature	-55			0			70	°C

electrical characteristics over recommended operating free-air temperature range (unless otherwise noted)

PARAMETER	TEST CONDITIONS †	SN5437			SN7437			UNIT
		MIN	TYP ‡	MAX	MIN	TYP ‡	MAX	
V _{IK}	V _{CC} = MIN, I _I = -12 mA	-1.5			-1.5			V
V _{OH}	V _{CC} = MIN, V _{IL} = 0.8 V, I _{OH} = -1.2 mA	2.4	3.3		2.4	3.3		V
V _{OL}	V _{CC} = MIN, V _{IH} = 2 V, I _{OL} = 48 mA	0.2	0.4		0.2	0.4		V
I _I	V _{CC} = MAX, V _I = 5.5 V	1			1			mA
I _{IH}	V _{CC} = MAX, V _I = 2.4 V	40			40			μA
I _{IL}	V _{CC} = MAX, V _I = 0.4 V	-1.6			-1.6			mA
I _{OS} §	V _{CC} = MAX	-20	-70		-18	-70		mA
I _{CCH}	V _{CC} = MAX, V _I = 0 V	9	15.5		9	15.5		mA
I _{CCL}	V _{CC} = MAX, V _I = 4.5 V	34	54		34	54		mA

† For conditions shown as MIN or MAX, use the appropriate value specified under recommended operating conditions.

‡ All typical values are at V_{CC} = 5 V, T_A = 25°C.

§ Not more than one output should be shorted at a time, and the duration of the short circuit should not exceed one second.

switching characteristics, V_{CC} = 5 V, T_A = 25°C (see note 2)

PARAMETER	FROM (INPUT)	TO (OUTPUT)	TEST CONDITIONS	MIN	TYP	MAX	UNIT
t _{PLH}	A or B	Y	R _L = 133-Ω, C _L = 45 pF		13	22	ns
t _{PHL}				8	15	ns	

NOTE 2: See General Information Section for load circuits and voltage waveforms.



TTL DEVICES

TYPES SN54LS37, SN74LS37 QUADRUPLE 2-INPUT POSITIVE-NAND BUFFERS

recommended operating conditions

	SN54LS37			SN74LS37			UNIT
	MIN	NOM	MAX	MIN	NOM	MAX	
V _{CC} Supply voltage	4.5	5	5.5	4.75	5	5.25	V
V _{IH} High-level input voltage	2			2			V
V _{IL} Low-level input voltage			0.7			0.8	V
I _{OH} High-level output current			-1.2			-1.2	mA
I _{OL} Low-level output current			12			24	mA
T _A Operating free-air temperature	-55		125	0		70	°C

electrical characteristics over recommended operating free-air temperature range (unless otherwise noted)

PARAMETER	TEST CONDITIONS †	SN54LS37		SN74LS37		UNIT	
		MIN	TYP ‡	MAX	MIN		TYP ‡
V _{IK}	V _{CC} = MIN, I _I = -18 mA			-1.5		-1.5	V
V _{OH}	V _{CC} = MIN, V _{IL} = MAX, I _{OH} = -1.2 mA	2.5	3.4	2.7	3.4		V
V _{OL}	V _{CC} = MIN, V _{IH} = 2 V, I _{OL} = 12 mA		0.25	0.4	0.25	0.4	V
	V _{CC} = MIN, V _{IH} = 2 V, I _{OL} = 24 mA				0.35	0.5	
I _I	V _{CC} = MAX, V _I = 7 V			0.1		0.1	mA
I _{IH}	V _{CC} = MAX, V _I = 2.7 V			20		20	μA
I _{IL}	V _{CC} = MAX, V _I = 0.4 V			-0.4		-0.4	mA
I _{OS} §	V _{CC} = MAX	-30		-130	-30	-130	mA
I _{CC} H	V _{CC} = MAX, V _I = 0 V		0.9	2	0.9	2	mA
I _{CC} L	V _{CC} = MAX, V _I = 4.5 V		6	12	6	12	mA

† For conditions shown as MIN or MAX, use the appropriate value specified under recommended operating conditions.

‡ All typical values are at V_{CC} = 5 V, T_A = 25°C.

§ Not more than one output should be shorted at a time, and the duration of the short-circuit should not exceed one second.

switching characteristics, V_{CC} = 5 V, T_A = 25°C (see note 2)

PARAMETER	FROM (INPUT)	TO (OUTPUT)	TEST CONDITIONS		MIN	TYP	MAX	UNIT
t _{PLH}	A or B	Y	R _L = 667 Ω,	C _L = 45 pF		12	24	ns
t _{PHL}						12	24	ns

NOTE 2: See General Information Section for load circuits and voltage waveforms.

TYPES SN54S37, SN74S37 QUADRUPLE 2-INPUT POSITIVE-NAND BUFFERS

recommended operating conditions

	SN54S37			SN74S37			UNIT
	MIN	NOM	MAX	MIN	NOM	MAX	
V _{CC} Supply voltage	4.5	5	5.5	4.75	5	5.25	V
V _{IH} High-level input voltage	2			2			V
V _{IL} Low-level input voltage				0.8			V
I _{OH} High-level output current				-3			mA
I _{OL} Low-level output current				60			mA
T _A Operating free-air temperature	-55			125			°C

electrical characteristics over recommended operating free-air temperature range (unless otherwise noted)

PARAMETER	TEST CONDITIONS †	SN54S37		SN74S37		UNIT
		MIN	TYP ‡	MAX	MIN	
V _{IK}	V _{CC} = MIN, I _I = -18 mA			-1.2		V
V _{OH}	V _{CC} = MIN, V _{IL} = 0.8 V, I _{OH} = -3 mA	2.5	3.4	2.7	3.4	V
V _{OL}	V _{CC} = MIN, V _{IH} = 2 V, I _{OL} = 60 mA	0.5		0.5		V
I _I	V _{CC} = MAX, V _I = 5.5 V	1		1		mA
I _{IH}	V _{CC} = MAX, V _I = 2.7 V	0.1		0.1		mA
I _{IL}	V _{CC} = MAX, V _I = 0.5 V	-4		-4		mA
I _{OS} §	V _{CC} = MAX	-50	-225	-50	-225	mA
I _{CCH}	V _{CC} = MAX, V _I = 0 V	20 36		20 36		mA
I _{CCL}	V _{CC} = MAX, V _I = 4.5	46 80		46 80		mA

† For conditions shown as MIN or MAX, use the appropriate value specified under recommended operating conditions.

‡ All typical values are at V_{CC} = 5 V, T_A = 25°C.

§ Not more than one output should be shorted at a time, and the duration of the short circuit should not exceed 100 milliseconds.

switching characteristics, V_{CC} = 5 V, T_A = 25°C (see note 2)

PARAMETER	FROM (INPUT)	TO (OUTPUT)	TEST CONDITIONS		MIN	TYP	MAX	UNIT
t _{PLH}	A or B	Y	R _L = 93 Ω,	C _L = 50 pF	4	6.5	ns	
t _{PHL}					4	6.5	ns	
t _{PLH}			R _L = 93 Ω,	C _L = 150 pF	6		ns	
t _{PHL}					6		ns	

NOTE 2: See General Information Section for load circuits and voltage waveforms.

3

TTL DEVICES

TYPES SN5438, SN54LS38, SN54S38, SN7438, SN74LS38, SN74S38 QUADRUPLE 2-INPUT POSITIVE-NAND BUFFERS WITH OPEN-COLLECTOR OUTPUTS

REVISED DECEMBER 1983

- Package Options Include Both Plastic and Ceramic Chip Carriers in Addition to Plastic and Ceramic DIPs
- Dependable Texas Instruments Quality and Reliability

description

These devices contain four independent 2-input NAND buffer gates with open-collector outputs. The open-collector outputs require pull-up resistors to perform correctly. They may be connected to other open-collector outputs to implement active-low wired-OR or active-high wired-AND functions. Open-collector devices are often used to generate high V_{OH} levels.

The SN5438, SN54LS38, and SN54S38 are characterized for operation over the full military temperature range of -55°C to 125°C . The SN7438, SN74LS38, and SN74S38 are characterized for operation from 0°C to 70°C .

FUNCTION TABLE (each gate)

INPUTS		OUTPUT
A	B	Y
H	H	L
L	X	H
X	L	H

logic diagram (each gate)



positive logic

$$Y = \overline{A \cdot B} \text{ or } Y = \overline{A} + \overline{B}$$

SN5438, SN54LS38, SN54S38 ... J OR W PACKAGE
SN7438 ... J OR N PACKAGE
SN74LS38, SN74S38 ... D, J OR N PACKAGE
(TOP VIEW)

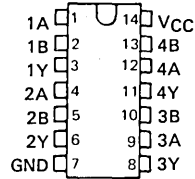

SN54LS38, SN54S38 ... FK PACKAGE
SN74LS38, SN74S38 ... FN PACKAGE
(TOP VIEW)

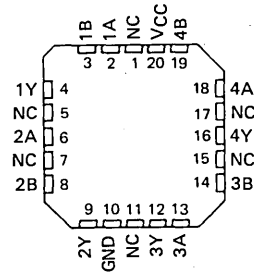

NC - No internal connection

3

TTL DEVICES

PRODUCTION DATA

This document contains information current as of publication date. Products conform to specifications per the terms of Texas Instruments standard warranty. Production processing does not necessarily include testing of all parameters.

TEXAS
INSTRUMENTS

POST OFFICE BOX 225012 • DALLAS, TEXAS 75265

TYPES SN5438, SN54LS38, SN54S38,
 SN7438, SN74LS38, SN74S38
 QUADRUPLE 2-INPUT POSITIVE-NAND BUFFERS WITH OPEN-COLLECTOR OUTPUTS

schematics (each gate)

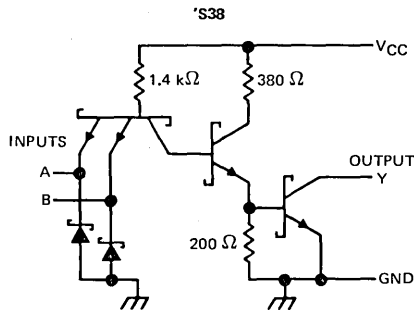
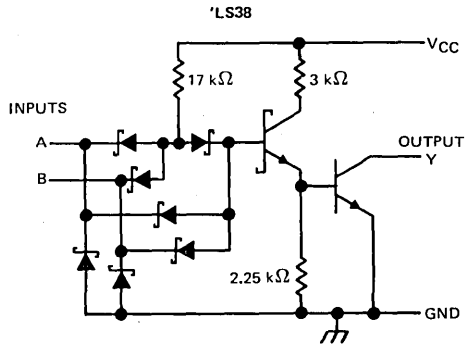
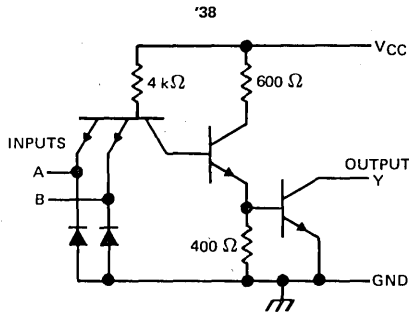

Resistor values shown are nominal.

absolute maximum ratings over operating free-air temperature (unless otherwise noted)

Supply voltage, V_{CC} (see Note 1)	7 V
Input voltage: '38	5.5 V
LS38	7 V
Off-state output voltage	7 V
Operating free-air temperature range: SN54'	-55°C to 125°C
SN74'	0°C to 70°C
Storage temperature range	-65°C to 150°C

NOTE 1: Voltage values are with respect to network ground terminal.

3

TTL DEVICES

TYPES SN5438, SN7438

QUADRUPLE 2-INPUT POSITIVE-NAND BUFFERS WITH OPEN-COLLECTOR OUTPUTS

recommended operating conditions

	SN5438			SN7438			UNIT
	MIN	NOM	MAX	MIN	NOM	MAX	
V _{CC} Supply voltage	4.5	5	5.5	4.75	5	5.25	V
V _{IH} High-level input voltage	2			2			V
V _{IL} Low-level input voltage				0.8			V
V _{OH} High-level output voltage				5.5			V
I _{OL} Low-level output current				48			mA
T _A Operating free-air temperature	-55			125			°C

electrical characteristics over recommended operating free-air temperature range (unless otherwise noted)

PARAMETER	TEST CONDITIONS †	MIN	TYP ‡	MAX	UNIT	
V _{IK}	V _{CC} = MIN, I _I = -12 mA			-1.5	V	
I _{OH}	V _{CC} = MIN, V _{IL} = 0.8 V, V _{OH} = 5.5 V			0.25	mA	
V _{OL}	V _{CC} = MIN, V _{IH} = 2 V, I _{OL} = 16 mA			0.4	V	
I _I	V _{CC} = MAX, V _I = 5.5 V			1	mA	
I _{IH}	V _{CC} = MAX, V _I = 2.4 V			40	μA	
I _{IL}	V _{CC} = MAX, V _I = 0.4 V			-1.6	mA	
I _{CCH}	V _{CC} = MAX, V _I = 0 V			5	8.5	mA
I _{CCL}	V _{CC} = MAX, V _I = 4.5 V			34	54	mA

† For conditions shown as MIN or MAX, use the appropriate value specified under recommended operating conditions.

‡ All typical values are at V_{CC} = 5 V, T_A = 25°C.

switching characteristics, V_{CC} = 5 V, T_A = 25°C (see note 2)

PARAMETER	FROM (INPUT)	TO (OUTPUT)	TEST CONDITIONS	MIN	TYP	MAX	UNIT
t _{PLH}	A or B	Y	R _L = 133 Ω, C _L = 45 pF		14	22	ns
t _{PHL}					11	18	ns

NOTE 2: See General Information Section for load circuits and voltage waveforms.

3
TTL DEVICES

TYPES SN54LS38, SN74LS38

QUADRUPLE 2-INPUT POSITIVE-NAND BUFFERS WITH OPEN-COLLECTOR OUTPUTS

recommended operating conditions

	SN54LS38			SN74LS38			UNIT
	MIN	NOM	MAX	MIN	NOM	MAX	
V _{CC} Supply voltage	4.5	5	5.5	4.75	5	5.25	V
V _{IH} High-level input voltage	2			2			V
V _{IL} Low-level input voltage			0.7			0.8	V
V _{OH} High-level output voltage			5.5			5.5	V
I _{OL} Low-level output current			12			24	mA
T _A Operating free-air temperature	-55		125	0		70	°C

electrical characteristics over recommended operating free-air temperature range (unless otherwise noted)

PARAMETER	TEST CONDITIONS †	SN54LS38		SN74LS38		UNIT	
		MIN	TYP ‡	MAX	MIN		TYP ‡
V _{IK}	V _{CC} = MIN, I _I = -18 mA			-1.5		-1.5	V
I _{OH}	V _{CC} = MIN, V _{IL} = MAX, V _{OH} = 5.5 V			0.25		0.25	mA
V _{OL}	V _{CC} = MIN, V _{IH} = 2 V, I _{OL} = 12 mA		0.25	0.4		0.25 0.4	V
	V _{CC} = MIN, V _{IH} = 2 V, I _{OL} = 24 mA					0.35 0.5	
I _I	V _{CC} = MAX, V _I = 7 V			0.1		0.1	mA
I _{IH}	V _{CC} = MAX, V _I = 2.7 V			20		20	μA
I _{IL}	V _{CC} = MAX, V _I = 0.4 V			-0.4		-0.4	mA
I _{CCH}	V _{CC} = MAX, V _I = 0 V		0.9	2		0.9 2	mA
I _{CCL}	V _{CC} = MAX, V _I = 4.5 V		6	12		6 12	mA

† For conditions shown as MIN or MAX, use the appropriate value specified under recommended operating conditions.

‡ All typical values are at V_{CC} = 5 V, T_A = 25°C.

switching characteristics, V_{CC} = 5 V, T_A = 25°C (see note 2)

PARAMETER	FROM (INPUT)	TO (OUTPUT)	TEST CONDITIONS	MIN	TYP	MAX	UNIT
t _{PLH}	A or B	Y	R _L = 667 Ω, C _L = 45 pF		20	32	ns
t _{PHL}				18	28	ns	

NOTE 2: See General Information Section for load circuits and voltage waveforms.

3

TTL DEVICES

TYPES SN54S38, SN74S38

QUADRUPLE 2-INPUT POSITIVE-NAND BUFFERS WITH OPEN-COLLECTOR OUTPUTS

recommended operating conditions

	SN54S38			SN74S38			UNIT
	MIN	NOM	MAX	MIN	NOM	MAX	
V _{CC} Supply voltage	4.5	5	5.5	4.75	5	5.25	V
V _{IH} High-level input voltage	2			2			V
V _{IL} Low-level input voltage	0.8			0.8			V
V _{OH} High-level output voltage	5.5			5.5			V
I _{OL} Low-level output current	60			60			mA
T _A Operating free-air temperature	-55			125			°C

electrical characteristics over recommended operating free-air temperature range (unless otherwise noted)

PARAMETER	TEST CONDITIONS †	MIN	TYP ‡	MAX	UNIT	
V _{IK}	V _{CC} = MIN, I _I = -18 mA			-1.2	V	
I _{OH}	V _{CC} = MIN, V _{IL} = 0.8 V, V _{OH} = 5.5 V			0.25	mA	
V _{OL}	V _{CC} = MIN, V _{IH} = 2 V, I _{OL} = 60 mA			0.5	V	
I _I	V _{CC} = MAX, V _I = 5.5 V			1	mA	
I _{IH}	V _{CC} = MAX, V _I = 2.7 V			0.1	mA	
I _{IL}	V _{CC} = MAX, V _I = 0.5 V			-4	mA	
I _{CCH}	V _{CC} = MAX, V _I = 0 V			20	36	mA
I _{CCL}	V _{CC} = MAX, V _I = 4.5 V			46	80	mA

† For conditions shown as MIN or MAX, use the appropriate value specified under recommended operating conditions.

‡ All typical values are at V_{CC} = 5 V, T_A = 25°C.

switching characteristics, V_{CC} = 5 V, T_A = 25°C (see note 2)

PARAMETER	FROM (INPUT)	TO (OUTPUT)	TEST CONDITIONS	MIN	TYP	MAX	UNIT
t _{PLH}	A or B	Y	R _L = 93 Ω, C _L = 50 pF	6.5	10	ns	
t _{PHL}				6.5	10	ns	
t _{PLH}			R _L = 93 Ω, C _L = 150 pF	9	ns		
t _{PHL}				8.5	ns		

NOTE 2: See General Information Section for load circuits and voltage waveforms.



TTL DEVICES

TYPES SN5439, SN7439 QUADRUPLE 2-INPUT POSITIVE NAND BUFFERS WITH OPEN-COLLECTOR OUTPUTS

REVISED MAY 1983

- Current Sinking Capability up to 80 mA
- Guaranteed Fan-Out of 30 Series 54/74 Loads
- Dependable Texas Instruments Quality and Reliability

description

These devices contain four independent 2-input NAND buffers. The open-collector outputs require pull-up resistors to perform correctly. They may be connected to other open-collector outputs to implement active-low wired-OR or active-high wired-AND functions. Open-collector devices are often used to generate higher V_{OH} levels.

The SN5439 is characterized for operation over the full military temperature range of -55°C to 125°C . The SN7439 is characterized for operation from 0°C to 70°C .

SN5439 . . . J PACKAGE
SN7439 . . . J OR N PACKAGE
(TOP VIEW)

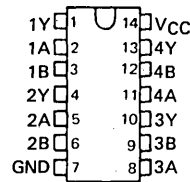

positive logic

$$Y = \overline{A \cdot B} \text{ or } Y = \overline{A} + \overline{B}$$

schematics (each gate)

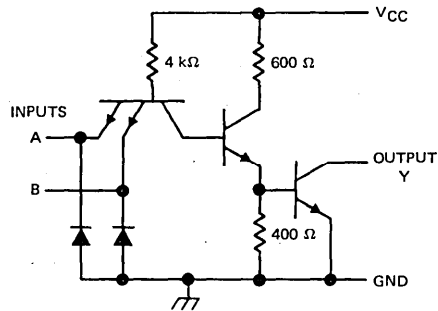

FUNCTION TABLE (each gate)

INPUTS		OUTPUT
A	B	Y
H	H	L
L	X	H
X	L	H

logic symbol †

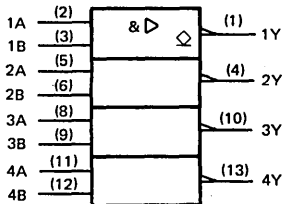

Pin numbers shown on logic notation are for J or N packages.

PRODUCTION DATA

This document contains information current as of publication date. Products conform to specifications per the terms of Texas Instruments standard warranty. Production processing does not necessarily include testing of all parameters.

TYPES SN5439, SN7439 QUADRUPLE 2-INPUT POSITIVE-NAND BUFFERS WITH OPEN-COLLECTOR OUTPUTS

absolute maximum ratings over operating free-air temperature range (unless otherwise noted)

Supply voltage, V_{CC} (see Note 1)	7V
Input voltage	7V
Off-state output voltage	7V
Operating free-air temperature range: SN5439	-55°C to 125°C
SN7439	0°C to 70°C
Storage temperature range	-65°C to 150°C

NOTE 1: Voltage values are with respect to network ground terminal.

recommended operating conditions

		SN5439			SN7439			UNIT
		MIN	NOM	MAX	MIN	NOM	MAX	
V_{CC}	Supply voltage	4.5	5	5.5	4.5	5	5.5	V
V_{IH}	High-level input voltage	2			2			V
V_{IL}	Low-level input voltage				0.8			V
V_{OH}	High-level output voltage				5.5			V
I_{OL}	Low-level output voltage				60			mA
					80†			
T_A	Operating free-air temperature	-55			125			°C

† The extended limit applies only if V_{CC} is maintained between 4.75 and 5.25 V.

electrical characteristics over recommended operating free-air temperature range (unless otherwise noted)

PARAMETER	TEST CONDITIONS†	SN5439			SN7439			UNIT
		MIN	TYP	MAX	MIN	TYP	MAX	
V_{IK}	$V_{CC} = \text{MIN}, I_I = -12 \text{ mA}$	-1.5			-1.5			V
I_{OH}	$V_{CC} = \text{MIN}, V_{OH} = 5.5 \text{ V}$	-0.25			-0.25			mA
V_{OL}	$V_{CC} = \text{MIN}, I_{OL} = 48 \text{ mA}$	0.4			0.4			V
	$V_{CC} = \text{MIN}, I_{OL} = 60 \text{ mA}$	0.5			0.5			
	$V_{CC} = 4.75 \text{ V}, I_{OL} = 80 \text{ mA}$				0.6			
I_I	$V_{CC} = \text{MAX}, V_I = 5.5 \text{ V}$	1			1			mA
I_{IH}	$V_{CC} = \text{MAX}, V_I = 2.4 \text{ V}$	40			40			μA
I_{IL}	$V_{CC} = \text{MAX}, V_I = 0.4 \text{ V}$	-1.6			-1.6			mA
I_{CCH}	$V_{CC} = \text{MAX}, V_I = \text{OV}$	54			54			mA

† For conditions shown as MIN or MAX, use the appropriate value specified under recommended operating conditions.

switching characteristics, $V_{CC} = 5 \text{ V}, T_A = 25^\circ \text{C}$ (see note 2)

PARAMETER	FROM (INPUT)	TO (OUTPUT)	TEST CONDITIONS	SN5439		SN7439		UNIT
				MIN	MAX	MIN	MAX	
t_{PLH}	A or B	Y	$R_L = 133 \Omega, C_L = 45 \text{ pF}$	22		22		ns
t_{PHL}				18		18		

NOTE 2: See General Information Section for load circuits and voltage waveforms.

3

TTL DEVICES

TYPES SN5440, SN54H40, SN54LS40, SN54S40, SN7440, SN74H40, SN74LS40, SN74S40 DUAL 4-INPUT POSITIVE-NAND BUFFERS

REVISED APRIL 1985

- Package Options Include Both Plastic and Ceramic Chip Carriers in Addition to Plastic and Ceramic DIPs
- Dependable Texas Instruments Quality and Reliability

description

These devices contain two independent 4-input NAND buffer gates.

The SN5440, SN54H40, SN54LS40, and SN54S40 are characterized for operation over the full military temperature range of -55°C to 125°C . The SN7440, SN74H40, SN74LS40, and SN74S40 are characterized for operation from 0°C to 70°C .

FUNCTION TABLE (each gate)

INPUTS				OUTPUT
A	B	C	D	Y
H	H	H	H	L
L	X	X	X	H
X	L	X	X	H
X	X	L	X	H
X	X	X	L	H

logic diagram (each gate)

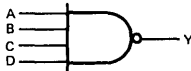

positive logic

$$Y = \overline{A \cdot B \cdot C \cdot D} \text{ or } Y = \overline{A + B + C + D}$$

SN5440, SN54H40 ... J PACKAGE
SN54LS40, SN54S40 ... J OR W PACKAGE
SN7440, SN74H40 ... J OR N PACKAGE
SN74LS40, SN74S40 ... D, J OR N PACKAGE

(TOP VIEW)

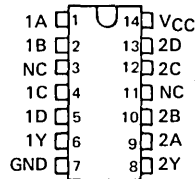

SN5440, SN54H40 ... W PACKAGE
(TOP VIEW)

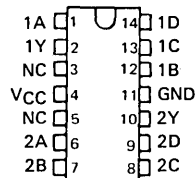

SN54LS40, SN54S40 ... FK PACKAGE
SN74LS40, SN74S40 ... FN PACKAGE

(TOP VIEW)

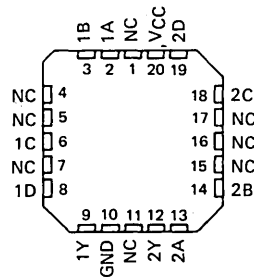

NC - No internal connection

3

TTL DEVICES

PRODUCTION DATA

This document contains information current as of publication date. Products conform to specifications per the terms of Texas Instruments standard warranty. Production processing does not necessarily include testing of all parameters.

TEXAS
INSTRUMENTS

POST OFFICE BOX 225012 • DALLAS, TEXAS 75265

3-175

**TYPES SN5440, SN54H40, SN54LS40, SN54S40,
SN7440, SN74H40, SN74LS40, SN74S40
DUAL 4-INPUT POSITIVE-NAND BUFFERS**

schematics (each gate)

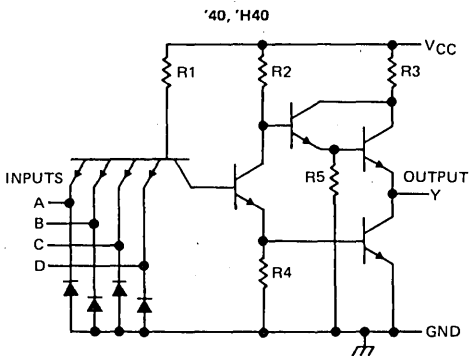

CIRCUIT	R1	R2	R3	R4	R5
'40	4 k Ω	600 Ω	100 Ω	400 Ω	4 k Ω
'H40	1.4 k Ω	390 Ω	45 Ω	250 Ω	2 k Ω

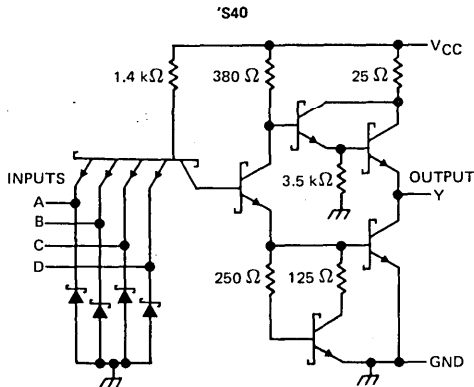
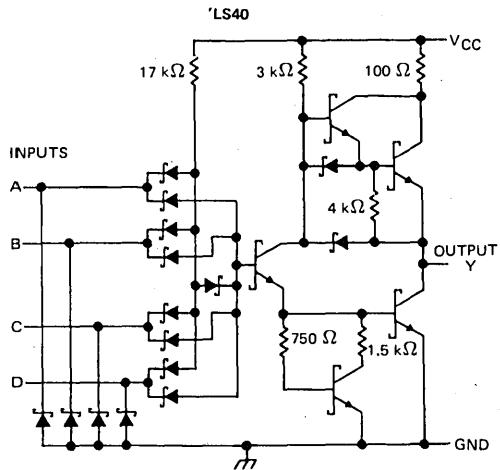

Resistor values shown are nominal.

absolute maximum ratings over operating free-air temperature (unless otherwise noted)

Supply voltage, V_{CC} (see Note 1)	7 V
Input voltage: '40, 'H40, 'S40	5.5 V
'LS40	7 V
Operating free-air temperature: SN54'	-55°C to 125°C
SN74'	0°C to 70°C
Storage temperature range	-65°C to 150°C

NOTE 1: Voltage values are with respect to network ground terminal.

3

TTL DEVICES

TYPES SN5440, SN7440 DUAL 4-INPUT POSITIVE-NAND BUFFERS

recommended operating conditions

	SN5440			SN7440			UNIT
	MIN	NOM	MAX	MIN	NOM	MAX	
V _{CC} Supply voltage	4.5	5	5.5	4.75	5	5.25	V
V _{IH} High-level input voltage	2			2			V
V _{IL} Low-level input voltage				0.8			V
I _{OH} High-level output current				-1.2			mA
I _{OL} Low-level output current				48			mA
T _A Operating free-air temperature	-55			125			°C

electrical characteristics over recommended operating free-air temperature range (unless otherwise noted)

PARAMETER	TEST CONDITIONS †	SN5440			SN7440			UNIT
		MIN	TYP ‡	MAX	MIN	TYP ‡	MAX	
V _{IK}	V _{CC} = MIN, I _I = -12 mA	-1.5			-1.5			V
V _{OH}	V _{CC} = MIN, V _{IL} = 0.8 V, I _{OH} = -1.2 mA	2.4	3.3		2.4	3.3	V	
V _{OL}	V _{CC} = MIN, V _{IH} = 2 V, I _{OL} = 48 mA	0.2			0.4			V
I _I	V _{CC} = MAX, V _I = 5.5 V	1			1			mA
I _{IH}	V _{CC} = MAX, V _I = 2.4 V	40			40			µA
I _{IL}	V _{CC} = MAX, V _I = 0.4 V	-1.6			-1.6			mA
I _{OS} §	V _{CC} = MAX	-20			-18			mA
I _{CCH}	V _{CC} = MAX, V _I = 0 V	4			4			mA
I _{CCL}	V _{CC} = MAX, V _I = 4.5 V	17			17			mA

† For conditions shown as MIN or MAX, use the appropriate value specified under recommended operating conditions.

‡ All typical values are at V_{CC} = 5 V, T_A = 25°C.

§ Not more than one output should be shorted at a time, and the duration of the short circuit should not exceed 100 milliseconds.

switching characteristics, V_{CC} = 5 V, T_A = 25°C (see note 2)

PARAMETER	FROM (INPUT)	TO (OUTPUT)	TEST CONDITIONS	MIN	TYP	MAX	UNIT
t _{PLH}	Any	Y	R _L = 133 Ω, C _L = 15 pF			13	ns
t _{PHL}				8	15	ns	

NOTE 2: See General Information Section for load circuits and voltage waveforms.

3

TTL DEVICES

TYPES SN54H40, SN74H40

DUAL 4-INPUT POSITIVE-NAND BUFFERS

recommended operating conditions

	SN54H40			SN74H40			UNIT
	MIN	NOM	MAX	MIN	NOM	MAX	
V _{CC} Supply voltage	4.5	5	5.5	4.75	5	5.25	V
V _{IH} High-level input voltage	2			2			V
V _{IL} Low-level input voltage	0.8			0.8			V
I _{OH} High-level output current	-1.5			-1.5			mA
I _{OL} Low-level output current	60			60			mA
T _A Operating free-air temperature	-55			0			70 °C

electrical characteristics over recommended operating free-air temperature range (unless otherwise noted)

PARAMETER	TEST CONDITIONS †	SN54H40		SN74H40		UNIT
		MIN	TYP ‡	MAX	MIN	
V _{IK}	V _{CC} = MIN, I _I = -8 mA			-1.5		V
V _{OH}	V _{CC} = MIN, V _{IL} = 0.8 V, I _{OH} = -1.5 mA	2.4	3.4	2.4	3.4	V
V _{OL}	V _{CC} = MIN, V _{IH} = 2 V, I _{OL} = 60 mA	0.2		0.2	0.4	V
I _I	V _{CC} = MAX, V _I = 5.5 V			0.1		mA
I _{IH}	V _{CC} = MAX, V _I = 2.4 V			0.1		mA
I _{IL}	V _{CC} = MAX, V _I = 0.4 V			-4		mA
I _{OS} §	V _{CC} = MAX	-40		-40	-125	mA
I _{CCH}	V _{CC} = MAX, V _I = 0 V	10.4		16		mA
I _{CCL}	V _{CC} = MAX, V _I = 4.5 V	25		40		mA

† For conditions shown as MIN or MAX, use the appropriate value specified under recommended operating conditions.

‡ All typical values are at V_{CC} = 5 V, T_A = 25°C.

§ Not more than one output should be shorted at a time, and the duration of the short-circuit should not exceed one second.

switching characteristics, V_{CC} = 5 V, T_A = 25°C (see note 2)

PARAMETER	FROM (INPUT)	TO (OUTPUT)	TEST CONDITIONS		MIN	TYP	MAX	UNIT	
t _{PLH}	Any	Y	R _L = 93 Ω,	C _L = 25 pF			8.5	12	ns
t _{PHL}							6.5	12	ns

NOTE 2: See General Information Section for load circuits and voltage waveforms.

3

TTL DEVICES

TYPES SN54LS40, SN74LS40 DUAL 4-INPUT POSITIVE-NAND BUFFERS

recommended operating conditions

	SN54LS40			SN74LS40			UNIT
	MIN	NOM	MAX	MIN	NOM	MAX	
V _{CC} Supply voltage	4.5	5	5.5	4.75	5	5.25	V
V _{IH} High-level input voltage	2			2			V
V _{IL} Low-level input voltage				0.7			V
I _{OH} High-level output current	-1.2			-1.2			mA
I _{OL} Low-level output current	12			24			mA
T _A Operating free-air temperature	-55 125			0 70			°C

electrical characteristics over recommended operating free-air temperature range (unless otherwise noted)

PARAMETER	TEST CONDITIONS †	SN54LS40			SN74LS40			UNIT
		MIN	TYP ‡	MAX	MIN	TYP ‡	MAX	
V _{IK}	V _{CC} = MIN, I _I = -18 mA	-1.5			-1.5			V
V _{OH}	V _{CC} = MIN, V _{IL} = MAX, I _{OH} = -1.2 mA	2.5	3.4		2.7	3.4		V
V _{OL}	V _{CC} = MIN, V _{IH} = 2 V, I _{OL} = 12 mA	0.25 0.4		0.25 0.4				V
	V _{CC} = MIN, V _{IH} = 2 V, I _{OL} = 24 mA			0.35 0.5				
I _I	V _{CC} = MAX, V _I = 7 V	0.1			0.1			mA
I _{IH}	V _{CC} = MAX, V _I = 2.7 V	20			20			μA
I _{IL}	V _{CC} = MAX, V _I = 0.4 V	-0.4			-0.4			mA
I _{OS} §	V _{CC} = MAX	-30		-130	-30		-130	mA
I _{CCH}	V _{CC} = MAX, V _I = 0 V	0.45 1		0.45 1				mA
I _{CCL}	V _{CC} = MAX, V _I = 4.5 V	3 6		3 6				mA

† For conditions shown as MIN or MAX, use the appropriate value specified under recommended operating conditions.

‡ All typical values are at V_{CC} = 5 V, T_A = 25°C.

§ Not more than one output should be shorted at a time, and the duration of the short circuit should not exceed one second.

switching characteristics, V_{CC} = 5 V, T_A = 25°C (see note 2)

PARAMETER	FROM (INPUT)	TO (OUTPUT)	TEST CONDITIONS		MIN	TYP	MAX	UNIT	
t _{PLH}	Any	Y	R _L = 667 Ω,	C _L = 45 pF			12	24	ns
t _{PHL}							12	24	ns

NOTE 2: See General Information Section for load circuits and voltage waveforms.

3

TTL DEVICES

TYPES SN54S40, SN74S40

DUAL 4-INPUT POSITIVE-NAND BUFFERS

recommended operating conditions

	SN54S40			SN74S40			UNIT
	MIN	NOM	MAX	MIN	NOM	MAX	
V _{CC} Supply voltage	4.5	5	5.5	4.75	5	5.25	V
V _{IH} High-level input voltage	2			2			V
V _{IL} Low-level input voltage	0.8			0.8			V
I _{OH} High-level output current	-3			-3			mA
I _{OL} Low-level output current	60			60			mA
T _A Operating free-air temperature	-55	125		0	70		°C

electrical characteristics over recommended operating free-air temperature range (unless otherwise noted)

PARAMETER	TEST CONDITIONS †	SN54S40		SN74S40		UNIT
		MIN	TYP ‡	MAX	MIN	
V _{IK}	V _{CC} = MIN, I _I = -18 mA	-1.2		-1.2		V
V _{OH}	V _{CC} = MIN, V _{IL} = 0.8 V, I _{OH} = -3 mA	2.5	3.4	2.7	3.4	V
V _{OL}	V _{CC} = MIN, V _{IH} = 2 V, I _{OL} = 60 mA	0.5		0.5		V
I _I	V _{CC} = MAX, V _I = 5.5 V	1		1		mA
I _{IH}	V _{CC} = MAX, V _I = 2.7 V	0.1		0.1		mA
I _{IL}	V _{CC} = MAX, V _I = 0.5 V	-4		-4		mA
I _{OS} §	V _{CC} = MAX	-50	-225	-50	-225	mA
I _{CCH}	V _{CC} = MAX, V _I = 0 V	10 18		10 18		mA
I _{CCL}	V _{CC} = MAX, V _I = 4.5 V	25 44		25 44		mA

† For conditions shown as MIN or MAX, use the appropriate value specified under recommended operating conditions.

‡ All typical values are at V_{CC} = 5 V, T_A = 25°C.

§ Not more than one output should be shorted at a time, and the duration of the short-circuit should not exceed 100 milliseconds.

switching characteristics, V_{CC} = 5 V, T_A = 25°C (see note 2)

PARAMETER	FROM (INPUT)	TO (OUTPUT)	TEST CONDITIONS	MIN	TYP	MAX	UNIT
t _{PLH}	Any	Y	R _L = 93 Ω, C _L = 50 pF	4	6.5	ns	
t _{PHL}				4	6.5	ns	
t _{PLH}			R _L = 93 Ω, C _L = 150 pF	6	ns		
t _{PHL}				6	ns		

NOTE 2: See General Information Section for load circuits and voltage waveforms.

3

TTL DEVICES

**TYPES SN5442A THRU SN5444A, SN54L42 THRU SN54L44,
SN54LS42, SN7442A THRU SN7444A, SN74LS42
4-LINE TO 10-LINE DECODERS (1-OF-10)**

MARCH 1974 - REVISED APRIL 1985

'42A, 'L42, 'LS42 ... BCD-TO-DECIMAL
'43A, 'L43 ... EXCESS-3-TO-DECIMAL
'44A, 'L44 ... GRAY-TO-DECIMAL

- All Outputs Are High for Invalid Input Conditions
- Also for Application as
4-Line-to-16-Line Decoders
3-Line-to-8-Line Decoders
- Diode-Clamped Inputs

SN5442A THRU SN5444A, SN54LS42 ... J OR W PACKAGE
SN54L42 THRU SN54L44 ... J PACKAGE
SN7442A THRU SN7444A ... J OR N PACKAGE
SN74LS42 ... D, J OR N PACKAGE

TYPES	TYPICAL POWER DISSIPATION	TYPICAL PROPAGATION DELAYS
'42A, '43A, '44A	140 mW	17 ns
'L42, 'L43, 'L44	70 mW	49 ns
'LS42	35 mW	17 ns

(TOP VIEW)

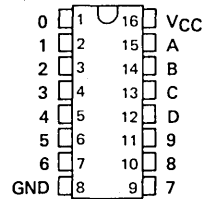

description

These monolithic decimal decoders consist of eight inverters and ten four-input NAND gates. The inverters are connected in pairs to make BCD input data available for decoding by the NAND gates. Full decoding of valid input logic ensures that all outputs remain off for all invalid input conditions.

The '42A, 'L42, and 'LS42 BCD-to-decimal decoders, the '43A and 'L43 excess-3-to-decimal decoders, and the '44A and 'L44 gray-to-decimal decoders feature inputs and outputs that are compatible for use with most TTL and other saturated low-level logic circuits. DC noise margins are typically one volt.

Series 54, 54L, and 54LS circuits are characterized for operation over the full military temperature range of -55°C to 125°C; Series 74, and 74LS circuits are characterized for operation from 0°C to 70°C.

SN54LS42 ... FK PACKAGE
SN74LS42 ... FN PACKAGE

(TOP VIEW)

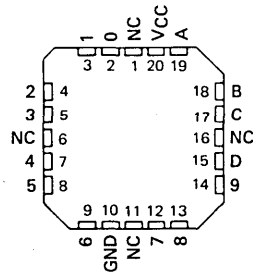

NC - No internal connection

PRODUCTION DATA
This document contains information current as of publication date. Products conform to specifications per the terms of Texas Instruments standard warranty. Production processing does not necessarily include testing of all parameters.



POST OFFICE BOX 225012 • DALLAS, TEXAS 75265



TYPES SN5442A, SN54L42, SN54LS42, SN7442A, SN74LS42
 4-LINE TO 10-LINE DECODERS (1-OF-10)

logic diagrams

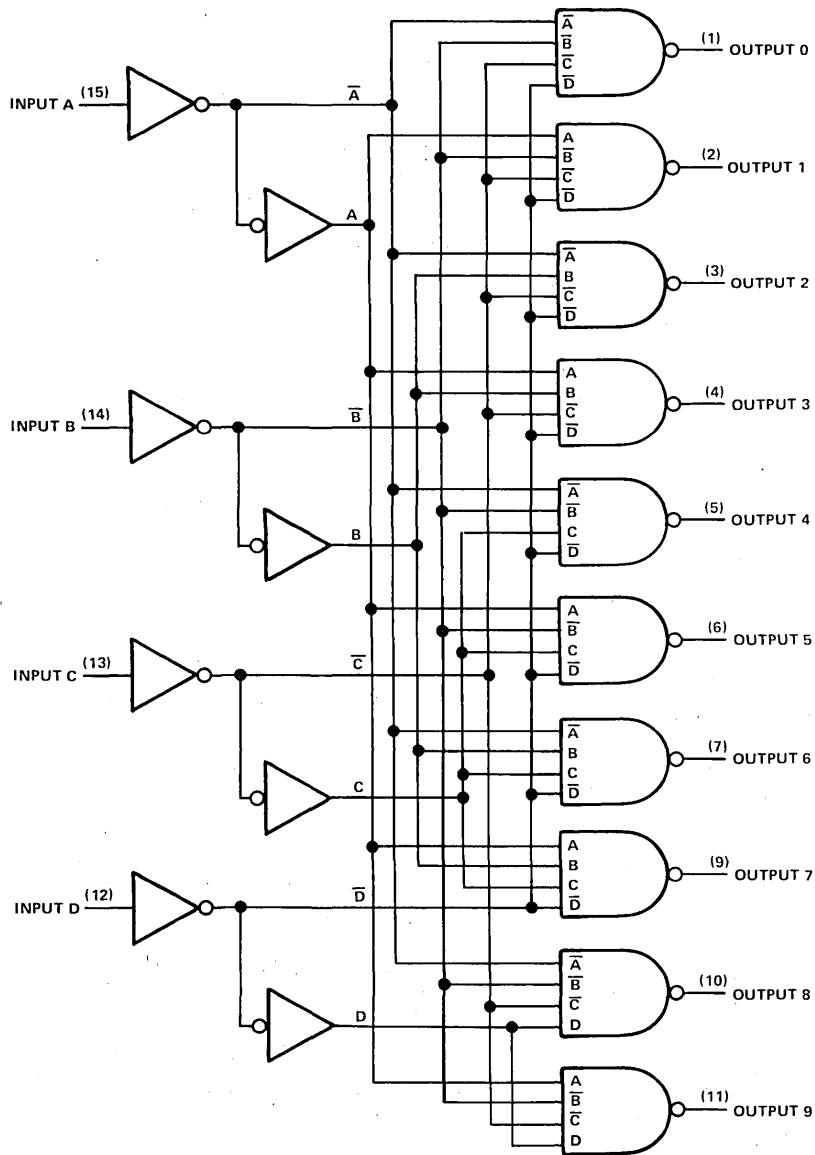

Pin numbers shown on logic notation are for D, J or N packages.

3

TTL DEVICES

TYPES SN5443A, SN54L43, SN7443A
4-LINE TO 10-LINE DECODERS (1-OF-10)

logic diagrams (continued)

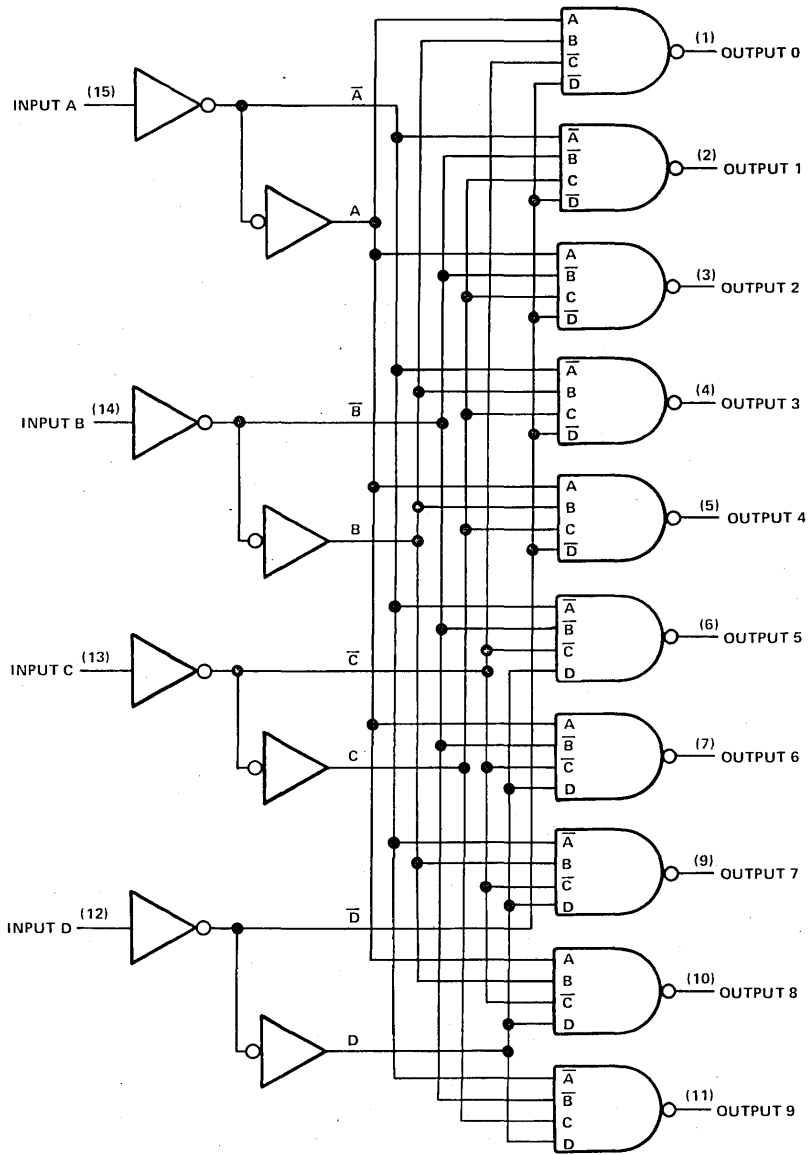

Pin numbers shown on logic notation are for D, J or N packages.

TYPES SN5444A, SN54L44, SN7444A
4-LINE TO 10-LINE DECODERS (1-OF-10)

logic diagrams (continued)

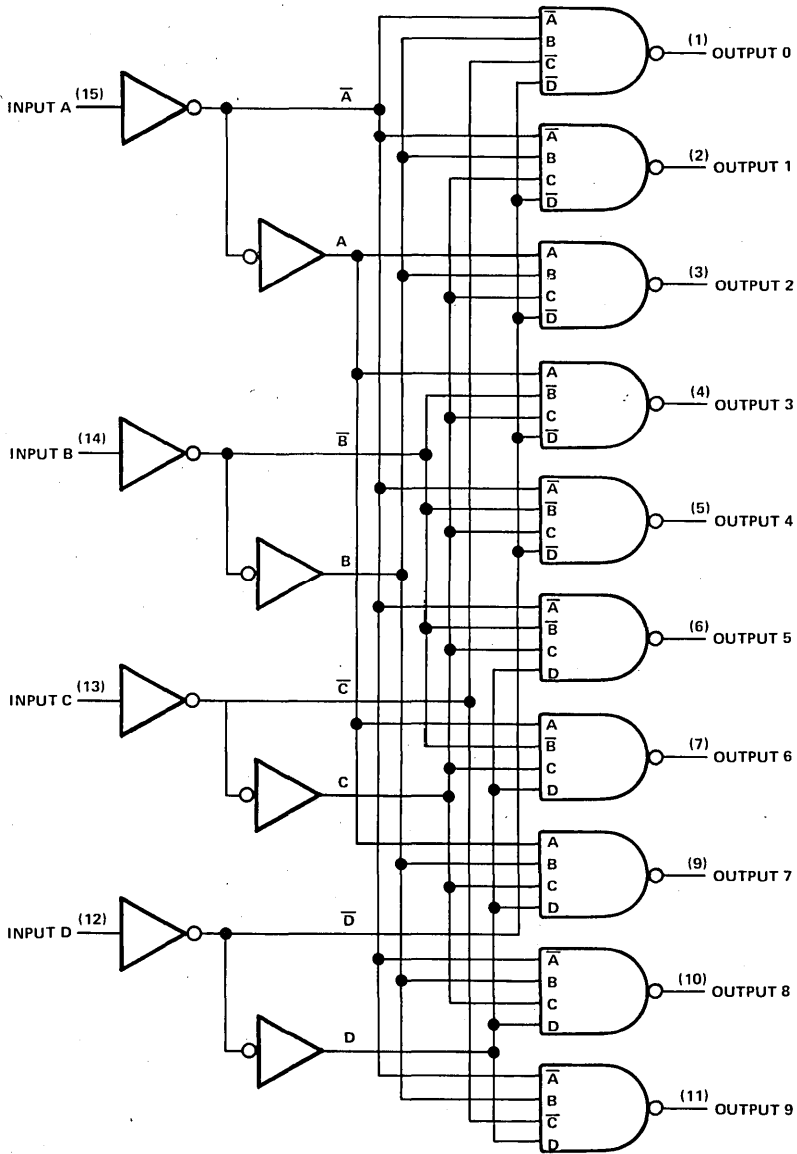

Pin numbers shown on logic notation are for D, J or N packages.

TYPES SN5442A THRU SN5444A, SN54L42 THRU SN54L44,
 SN54LS42, SN7442A THRU SN7444A, SN74LS42
 4-LINE TO 10-LINE DECODERS (1-OF-10)

schematics of inputs and outputs

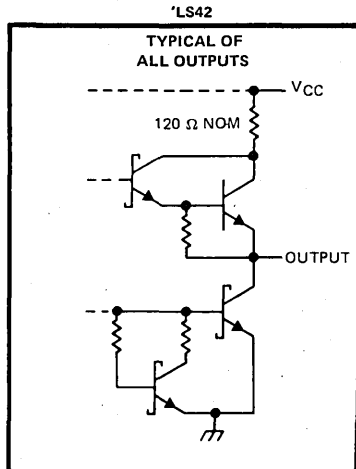
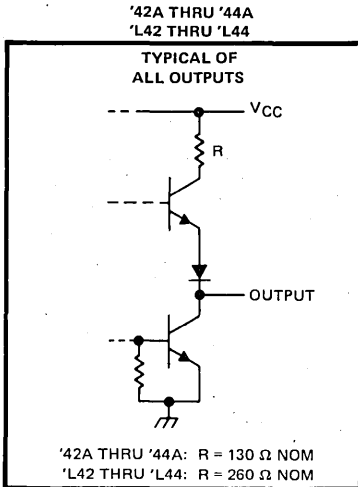
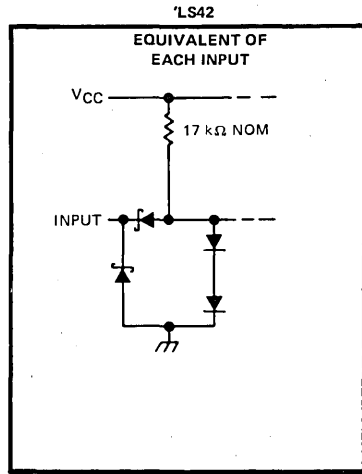
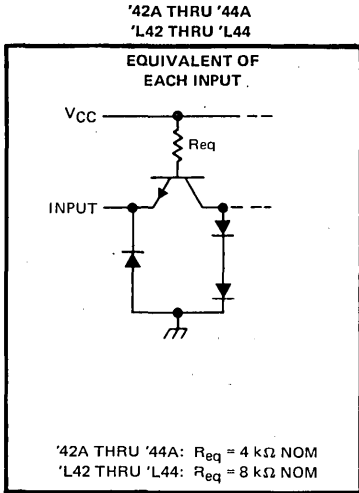

**TYPES SN5442A THRU SN5444A, SN54L42 THRU SN54L44,
SN54LS42, SN7442A THRU SN7444A, SN74LS42
4-LINE TO 10-LINE DECODERS (1-OF-10)**

FUNCTION TABLE

NO.	'42A, 'L42, 'LS42				'43A, 'L43				'44A, 'L44				ALL TYPES									
	BCD INPUT				EXCESS-3-INPUT				GRAY INPUT				DECIMAL OUTPUT									
	D	C	B	A	D	C	B	A	D	C	B	A	0	1	2	3	4	5	6	7	8	9
0	L	L	L	L	L	L	H	H	L	L	H	L	L	H	H	H	H	H	H	H	H	H
1	L	L	L	H	L	H	L	L	L	H	H	L	L	H	H	H	H	H	H	H	H	H
2	L	L	H	L	L	H	L	H	L	H	H	H	L	H	H	H	H	H	H	H	H	H
3	L	L	H	H	L	H	H	L	L	H	L	H	L	H	L	H	H	H	H	H	H	H
4	L	H	L	L	L	H	H	H	L	H	L	L	L	H	H	H	H	L	H	H	H	H
5	L	H	L	H	H	L	L	L	L	H	H	L	L	L	H	H	H	L	H	H	H	H
6	L	H	H	L	H	L	L	H	L	H	H	L	H	L	H	H	H	H	L	H	H	H
7	L	H	H	H	H	L	H	L	L	H	H	H	H	L	H	H	H	H	H	L	H	H
8	H	L	L	L	H	L	H	H	L	H	H	H	L	L	H	H	H	H	H	L	H	H
9	H	L	L	H	H	H	L	L	L	H	L	H	L	L	H	H	H	H	H	H	H	L
INVALID	H	L	H	L	H	H	L	H	L	H	H	H	H	H	H	H	H	H	H	H	H	H
	H	L	H	H	H	H	H	L	L	L	L	L	L	H	H	H	H	H	H	H	H	H
	H	H	L	L	H	H	H	H	L	L	L	L	L	H	H	H	H	H	H	H	H	H
	H	H	L	H	L	L	L	L	L	L	L	L	L	H	H	H	H	H	H	H	H	H
	H	H	H	L	L	L	L	H	L	L	L	H	L	L	H	H	H	H	H	H	H	H

H = high level, L = low level

absolute maximum ratings over operating free-air temperature range (unless otherwise noted)

Supply voltage, V_{CC} (see Note.1)	7 V
Input voltage: '42A, '43A, '44A	5.5 V
'L42, 'L43, 'L44	5.5 V
'LS42	7 V
Operating free-air temperature: SN54'	-55°C to 125°C
SN74'	0°C to 70°C
Storage temperature range	-65°C to 150°C

NOTE 1: Voltage values are with respect to network ground terminal.

3

TTL DEVICES

TYPES SN5442A, SN5443A, SN5444A, SN7442A, SN7443A, SN7444A
4-LINE TO 10-LINE DECODERS (1-OF-10)

recommended operating conditions

	SN5442A SN5443A SN5444A			SN7442A SN7443A SN7444A			UNIT
	MIN	NOM	MAX	MIN	NOM	MAX	
Supply voltage, V_{CC}	4.5	5	5.5	4.75	5	5.25	V
High-level output current, I_{OH}			-800			-800	μ A
Low-level output current, I_{OL}			16			16	mA
Operating free-air temperature, T_A	-55		125	0		70	$^{\circ}$ C

electrical characteristics over recommended operating free-air temperature range (unless otherwise noted)

PARAMETER	TEST CONDITIONS†	SN5442A SN5443A SN5444A			SN7442A SN7443A SN7444A			UNIT
		MIN	TYP‡	MAX	MIN	TYP‡	MAX	
V_{IH} High-level input voltage		2			2			V
V_{IL} Low-level input voltage		0.8			0.8			V
V_{IK} Input clamp voltage	$V_{CC} = \text{MIN}, I_I = -12 \text{ mA}$	-1.5			-1.5			V
V_{OH} High-level output voltage	$V_{CC} = \text{MIN}, V_{IH} = 2 \text{ V}, V_{IL} = 0.8 \text{ V}, I_{OH} = -800 \mu\text{A}$	2.4	3.4		2.4	3.4		V
V_{OL} Low-level output voltage	$V_{CC} = \text{MIN}, V_{IH} = 2 \text{ V}, V_{IL} = 0.8 \text{ V}, I_{OL} = 16 \text{ mA}$		0.2	0.4		0.2	0.4	V
I_I Input current at maximum input voltage	$V_{CC} = \text{MAX}, V_I = 5.5 \text{ V}$	1			1			mA
I_{IH} High-level input current	$V_{CC} = \text{MAX}, V_I = 2.4 \text{ V}$	40			40			μ A
I_{IL} Low level input current	$V_{CC} = \text{MAX}, V_I = 0.4 \text{ V}$	-1.6			-1.6			mA
I_{OS} Short-circuit output current §	$V_{CC} = \text{MAX}$	-20	-55		-18	-55		mA
I_{CC} Supply current	$V_{CC} = \text{MAX}$, See Note 2	28	41		28	56		mA

† For conditions shown as MIN or MAX, use the appropriate values specified under recommended operating conditions.

‡ All typical values are at $V_{CC} = 5 \text{ V}, T_A = 25^{\circ}\text{C}$.

§ Not more than one output should be shorted at a time.

NOTE 2: I_{CC} is measured with all outputs open and all inputs grounded.

switching characteristics, $V_{CC} = 5 \text{ V}, T_A = 25^{\circ}\text{C}$

PARAMETER	TEST CONDITIONS	MIN	TYP	MAX	UNIT	
t_{PHL} Propagation delay time, high-to-low-level output from A, B, C, or D through 2 levels of logic	$C_L = 15 \text{ pF}, R_L = 400 \Omega,$ See Note 3		14	25	ns	
t_{PHL} Propagation delay time, high-to-low-level output from A, B, C, or D through 3 levels of logic			17	30	ns	
t_{PLH} Propagation delay time, low-to-high-level output from A, B, C, and D through 2 levels of logic				10	25	ns
t_{PLH} Propagation delay time, low-to-high-level output from A, B, C, and D through 3 levels of logic				17	30	ns

NOTE 3: See General Information Section for load circuits and voltage waveforms.



TTL DEVICES

TYPES SN54L42, SN54L43, SN54L44
4-LINE TO 10-LINE DECODERS (1-OF-10)

recommended operating conditions

	SN54L42 SN54L43 SN54L44			UNIT
	MIN	NOM	MAX	
V _{CC} Supply voltage	4.5	5	5.5	V
V _{IH} High-level input voltage	2			V
V _{IL} Low-level input voltage				0.8 V
I _{OH} High-level output current				-0.4 mA
I _{OL} Low-level output current				8 mA
T _A Operating free-air temperature	-55	125		°C

electrical characteristics over recommended operating free-air temperature range (unless otherwise noted)

PARAMETER	TEST CONDITIONS†	MIN	TYP	MAX	UNIT
V _{IK}	V _{CC} = MIN, I _I = -12 mA	-1.5			V
V _{OH}	V _{CC} = MIN, V _{IH} = 2 V, V _{IL} = 0.8 V, I _{OH} = -400 μA	2.4	3.4		V
V _{OL}	V _{CC} = MIN, V _{IH} = 2 V, V _{IL} = 0.8 V, I _{OL} = 8 mA		0.2	0.4	V
I _I	V _{CC} = MAX, V _I = 5.5 V				1 mA
I _{IH}	V _{CC} = MAX, V _I = 2.4 V				20 μA
I _{IL}	V _{CC} = MAX, V _I = 0.4 V				-0.8 mA
I _{OS} ‡	V _{CC} = MAX	-9			-28 mA
I _{CC}	V _{CC} = MAX, See Note 2	14			22 mA

† For conditions shown as MIN or MAX, use the appropriate values specified under recommended operating conditions.

All typical values are at V_{CC} = 5 V, T_A = 25°C.

‡ Not more than one output should be shorted at a time.

NOTE 2: I_{CC} is measured with all outputs open and inputs grounded.

switching characteristics, V_{CC} = 5 V, T_A = 25°C

PARAMETER	TEST CONDITIONS	MIN	TYP	MAX	UNIT
^t PHL Propagation delay time, high-to-low-level output from A, B, C, or D through 2 levels of logic	C _L = 15 pF, R _L = 800 Ω, See Note 3	10	44	60	ns
^t PHL Propagation delay time, high-to-low-level output from A, B, C, or D through 3 levels of logic		46	70		ns
^t PLH Propagation delay time, low-to-high-level output from A, B, C, and D through 2 levels of logic		10	34	50	ns
^t PLH Propagation delay time, low-to-high-level output from A, B, C, and D through 3 levels of logic		52	70		ns

NOTE 3: See General Information Section for load circuits and voltage waveforms.

3

TTL DEVICES

TYPES SN54LS42, SN74LS42
4-LINE TO 10-LINE DECODERS (1-OF-10)

recommended operating conditions

	SN54LS42			SN74LS42			UNIT
	MIN	NOM	MAX	MIN	NOM	MAX	
Supply voltage, V_{CC}	4.5	5	5.5	4.75	5	5.25	V
High-level output current, I_{OH}	-400			-400			μ A
Low-level output current, I_{OL}	4			8			mA
Operating free-air temperature, T_A	-55	125		0	70		$^{\circ}$ C

electrical characteristics over recommended operating free-air temperature range (unless otherwise noted)

PARAMETER	TEST CONDITIONS†	SN54LS42			SN74LS42			UNIT
		MIN	TYP‡	MAX	MIN	TYP‡	MAX	
V_{IH} High-level input voltage		2			2			V
V_{IL} Low-level input voltage		0.7			0.8			V
V_{IK} Input clamp voltage	$V_{CC} = \text{MIN}, I_I = -18 \text{ mA}$	-1.5			-1.5			V
V_{OH} High-level output voltage	$V_{CC} = \text{MIN}, V_{IH} = 2 \text{ V}, V_{IL} = V_{IL \text{ max}}, I_{OH} = -400 \mu\text{A}$	2.5	3.5		2.7	3.5		V
V_{OL} Low-level output voltage	$V_{CC} = \text{MIN}, V_{IH} = 2 \text{ V}, V_{IL} = V_{IL \text{ max}}$	$I_{OL} = 4 \text{ mA}$		0.25	0.4	0.25	0.4	V
		$I_{OL} = 8 \text{ mA}$				0.35	0.5	
I_I Input current at maximum input voltage	$V_{CC} = \text{MAX}, V_I = 7 \text{ V}$	0.1			0.1			mA
I_{IH} High-level input current	$V_{CC} = \text{MAX}, V_I = 2.7 \text{ V}$	20			20			μ A
I_{IL} Low-level input current	$V_{CC} = \text{MAX}, V_I = 0.4 \text{ V}$	-0.4			-0.4			mA
I_{OS} Short-circuit output current§	$V_{CC} = \text{MAX}$	-20	-100		-20	-100		mA
I_{CC} Supply current	$V_{CC} = \text{MAX},$ See Note 2	7 13			7 13			mA

† For conditions shown as MIN or MAX, use the appropriate value specified under recommended operating conditions.

‡ All typical values are at $V_{CC} = 5 \text{ V}, T_A = 25^{\circ}\text{C}$.

§ Not more than one output should be shorted at a time, and duration of the short-circuit should not exceed one second.

NOTE 2. I_{CC} is measured with all outputs open and inputs grounded.

switching characteristics, $V_{CC} = 5 \text{ V}, T_A = 25^{\circ}\text{C}$

PARAMETER	TEST CONDITIONS	MIN	TYP	MAX	UNIT
t_{PHL} Propagation delay time, high-to-low-level output from A, B, C, or D through 2 levels of logic	$C_L = 15 \text{ pF}, R_L = 2 \text{ k}\Omega,$ See Note 3	15		25	ns
t_{PHL} Propagation delay time, high-to-low-level output from A, B, C, or D through 3 levels of logic		20		30	ns
t_{PLH} Propagation delay time, low-to-high-level output from A, B, C, and D through 2 levels of logic		15		25	ns
t_{PLH} Propagation delay time, low-to-high-level output from A, B, C, and D through 3 levels of logic		20		30	ns

Note 3: See General Information Section for load circuits and voltage waveforms.



TTL DEVICES

TYPES SN5445, SN7445 BCD-TO-DECIMAL DECODERS/DRIVERS

DECEMBER 1972—REVISED DECEMBER 1983

FOR USE AS LAMP, RELAY, OR MOS DRIVERS

featuring

- Full Decoding of Input Logic
- 80-mA Sink-Current Capability
- All Outputs Are Off for Invalid BCD Input Conditions

logic

FUNCTION TABLE

NO.	INPUTS				OUTPUTS									
	D	C	B	A	0	1	2	3	4	5	6	7	8	9
0	L	L	L	L	L	H	H	H	H	H	H	H	H	H
1	L	L	L	H	H	L	H	H	H	H	H	H	H	H
2	L	L	H	L	H	H	L	H	H	H	H	H	H	H
3	L	L	H	H	H	H	L	H	H	H	H	H	H	H
4	L	H	L	L	H	H	H	H	L	H	H	H	H	H
5	L	H	L	H	H	H	H	H	L	H	H	H	H	H
6	L	H	H	L	H	H	H	H	H	L	H	H	H	H
7	L	H	H	H	H	H	H	H	H	H	L	H	H	H
8	H	L	L	L	H	H	H	H	H	H	H	L	H	H
9	H	L	L	H	H	H	H	H	H	H	H	H	L	L
INVALID	H	L	H	L	H	H	H	H	H	H	H	H	H	H
	H	L	H	H	H	H	H	H	H	H	H	H	H	H
	H	H	L	L	H	H	H	H	H	H	H	H	H	H
	H	H	L	H	H	H	H	H	H	H	H	H	H	H
	H	H	H	H	H	H	H	H	H	H	H	H	H	H

H = high level (off), L = low level (on)

description

These monolithic BCD-to-decimal decoders/drivers consist of eight inverters and ten four-input NAND gates. The inverters are connected in pairs to make BCD input data available for decoding by the NAND gates. Full decoding of valid BCD input logic ensures that all outputs remain off for all invalid binary input conditions. These decoders feature TTL inputs and high-performance, n-p-n output transistors designed for use as indicator/relay drivers or as open-collector logic-circuit drivers. Each of the high-breakdown output transistors (30 volts) will sink up to 80 milliamperes of current. Each input is one normalized Series 54/74 load. Inputs and outputs are entirely compatible for use with TTL logic circuits, and the outputs are compatible for interfacing with most MOS integrated circuits. Power dissipation is typically 215 milliwatts.

SN5445 . . . J OR W PACKAGE
SN7445 . . . J OR N PACKAGE
(TOP VIEW)

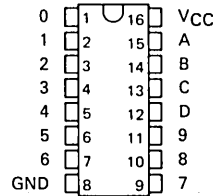

logic diagram

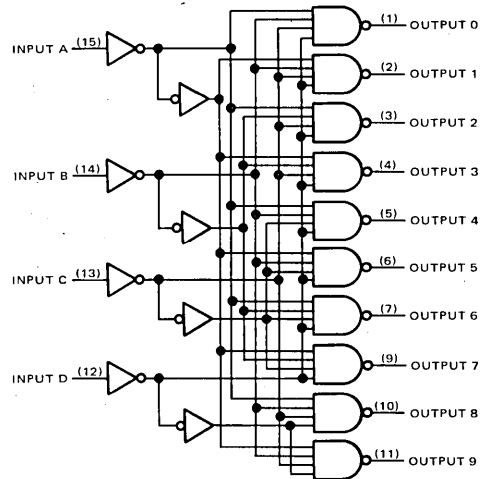

logic symbol

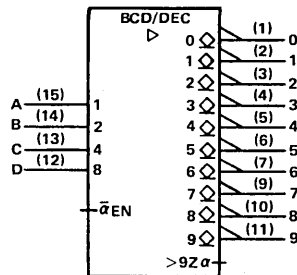

Pin numbers shown in logic notation are for J or N packages.

PRODUCTION DATA

This document contains information current as of publication date. Products conform to specifications per the terms of Texas Instruments standard warranty. Production processing does not necessarily include testing of all parameters.

3-190

TEXAS
INSTRUMENTS

POST OFFICE BOX 225012 • DALLAS, TEXAS 75265

TYPES SN5445, SN7445 BCD-TO-DECIMAL DECODERS/DRIVERS

absolute maximum ratings over operating free-air temperature range (unless otherwise noted)

Supply voltage, V_{CC} (see Note 1)	7 V
Input voltage	5.5 V
Maximum current into any output (off-state)	1 mA
Operating free-air temperature range: SN5445 Circuits	-55°C to 125°C
SN7445 Circuits	0°C to 70°C
Storage temperature range	-65°C to 150°C

NOTE 1: Voltage values are with respect to network ground terminal.

recommended operating conditions

	SN5445			SN7445			UNIT	
	MIN	NOM	MAX	MIN	NOM	MAX		
Supply voltage, V_{CC}	4.5	5	5.5	4.75	5	5.25	V	
Off-state output voltage	30			30			V	
Operating free-air temperature, T_A	-55			0			70	°C

electrical characteristics over recommended operating free-air temperature range (unless otherwise noted)

PARAMETER	TEST CONDITIONS [†]	MIN	TYP [‡]	MAX	UNIT	
V_{IH} High-level input voltage		2			V	
V_{IL} Low-level input voltage			0.8		V	
V_{IK} Input clamp voltage	$V_{CC} = \text{MIN}, I_I = -12 \text{ mA}$			-1.5	V	
$V_{O(\text{on})}$ On-state output voltage	$V_{CC} = \text{MIN}, V_{IH} = 2 \text{ V}, V_{IL} = 0.8 \text{ V}$			0.5	0.9	V
						$I_{O(\text{on})} = 80 \text{ mA}$
						$I_{O(\text{on})} = 20 \text{ mA}$
$I_{O(\text{off})}$ Off-state output current	$V_{CC} = \text{MIN}, V_{IH} = 2 \text{ V}, V_{IL} = 0.8 \text{ V}, V_{O(\text{off})} = 30 \text{ V}$			250	μA	
I_I Input current at maximum input voltage	$V_{CC} = \text{MAX}, V_I = 5.5 \text{ V}$			1	mA	
I_{IH} High-level input current	$V_{CC} = \text{MAX}, V_I = 2.4 \text{ V}$			40	μA	
I_{IL} Low-level input current	$V_{CC} = \text{MAX}, V_I = 0.4 \text{ V}$			-1.6	mA	
I_{CC} Supply current	$V_{CC} = \text{MAX}, \text{ See Note 2}$					SN5445
				43	62	SN7445
				43	70	

[†]For conditions shown as MIN or MAX, use the appropriate value specified under recommended operating conditions for the applicable type.

[‡]All typical values are at $V_{CC} = 5 \text{ V}, T_A = 25^\circ\text{C}$.

NOTE 2: I_{CC} is measured with all inputs grounded and outputs open.

switching characteristics, $V_{CC} = 5 \text{ V}, T_A = 25^\circ\text{C}$

PARAMETER	TEST CONDITIONS	MIN	TYP	MAX	UNIT
t_{PLH} Propagation delay time, low-to-high-level output	$C_L = 15 \text{ pF}, R_L = 100 \Omega, \text{ See Note 3}$			50	ns
t_{PHL} Propagation delay time, high-to-low-level output				50	ns

NOTE 3: See General Information Section for load circuits and voltage waveforms.

schematics of inputs and outputs

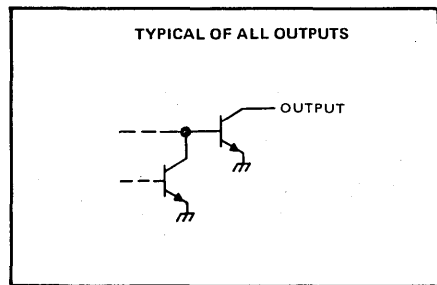
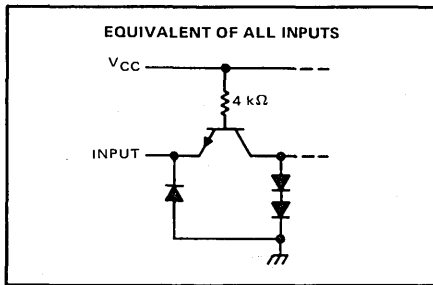

3
TTL DEVICES

3

TTL DEVICES

TYPES SN5446A, '47A, '48, '49, SN54L46, 'L47, SN54LS47, 'LS48, 'LS49, SN7446A, '47A, '48, SN74LS47, 'LS48, 'LS49 BCD-TO-SEVEN-SEGMENT DECODERS/DRIVERS

MARCH 1974. REVISED DECEMBER 1983

'46A, '47A, 'L46, 'L47, 'LS47
feature

- Open-Collector Outputs Drive Indicators Directly
- Lamp-Test Provision
- Leading/Trailing Zero Suppression

'48, 'LS48
feature

- Internal Pull-Ups Eliminate Need for External Resistors
- Lamp-Test Provision
- Leading/Trailing Zero Suppression

'49, 'LS49
feature

- Open-Collector Outputs
- Blanking Input

SN54L46, SN54L47 ... J PACKAGE
SN5446A, SN5447A, SN54LS47, SN5448,
SN54LS48 ... J OR W PACKAGE
SN7446A, SN7447A,
SN7448 ... J OR N PACKAGE
SN74LS47, SN74LS48 ... D, J OR N PACKAGE
(TOP VIEW)

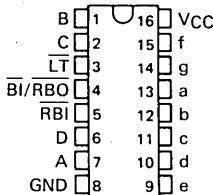

SN5449 ... W PACKAGE
SN54LS49 ... J OR W PACKAGE
SN74LS49 ... D, J OR N PACKAGE
(TOP VIEW)

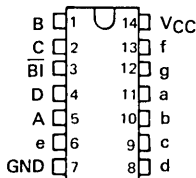

SN54LS47, SN54LS48 ... FK PACKAGE
SN74LS47, SN74LS48 ... FN PACKAGE
(TOP VIEW)

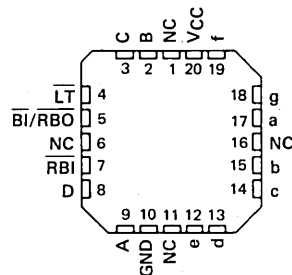

SN54LS49 ... FK PACKAGE
SN74LS49 ... FN PACKAGE
(TOP VIEW)

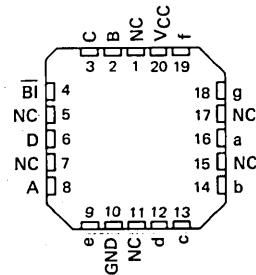

NC — No internal connection

PRODUCTION DATA
This document contains information current as of publication date. Products conform to specifications per the terms of Texas Instruments standard warranty. Production processing does not necessarily include testing of all parameters.

TEXAS INSTRUMENTS
POST OFFICE BOX 225012 • DALLAS, TEXAS 75265

3
TTL DEVICES

TYPES SN5446A, '47A, '48, '49, SN54L46, 'L47, SN54LS47, 'LS48, 'LS49, SN7446A, '47A, '48, SN74LS47, 'LS48, 'LS49 BCD-TO-SEVEN-SEGMENT DECODERS/DRIVERS

- All Circuit Types Feature Lamp Intensity Modulation Capability

TYPE	DRIVER OUTPUTS				TYPICAL POWER DISSIPATION	PACKAGES
	ACTIVE LEVEL	OUTPUT CONFIGURATION	SINK CURRENT	MAX VOLTAGE		
SN5446A	low	open-collector	40 mA	30 V	320 mW	J, W
SN5447A	low	open-collector	40 mA	15 V	320 mW	J, W
SN5448	high	2-k Ω pull-up	6.4 mA	5.5 V	265 mW	J, W
SN5449	high	open-collector	10 mA	5.5 V	165 mW	W
SN54L46	low	open-collector	20 mA	30 V	160 mW	J
SN54L47	low	open-collector	20 mA	15 V	160 mW	J
SN54LS47	low	open-collector	12 mA	15 V	35 mW	J, W
SN54LS48	high	2-k Ω pull-up	2 mA	5.5 V	125 mW	J, W
SN54LS49	high	open-collector	4 mA	5.5 V	40 mW	J, W
SN7446A	low	open-collector	40 mA	30 V	320 mW	J, N
SN7447A	low	open-collector	40 mA	15 V	320 mW	J, N
SN7448	high	2-k Ω pull-up	6.4 mA	5.5 V	265 mW	J, N
SN74LS47	low	open-collector	24 mA	15 V	35 mW	J, N
SN74LS48	high	2-k Ω pull-up	6 mA	5.5 V	125 mW	J, N
SN74LS49	high	open-collector	8 mA	5.5 V	40 mW	J, N

logic symbols

3

TTL DEVICES

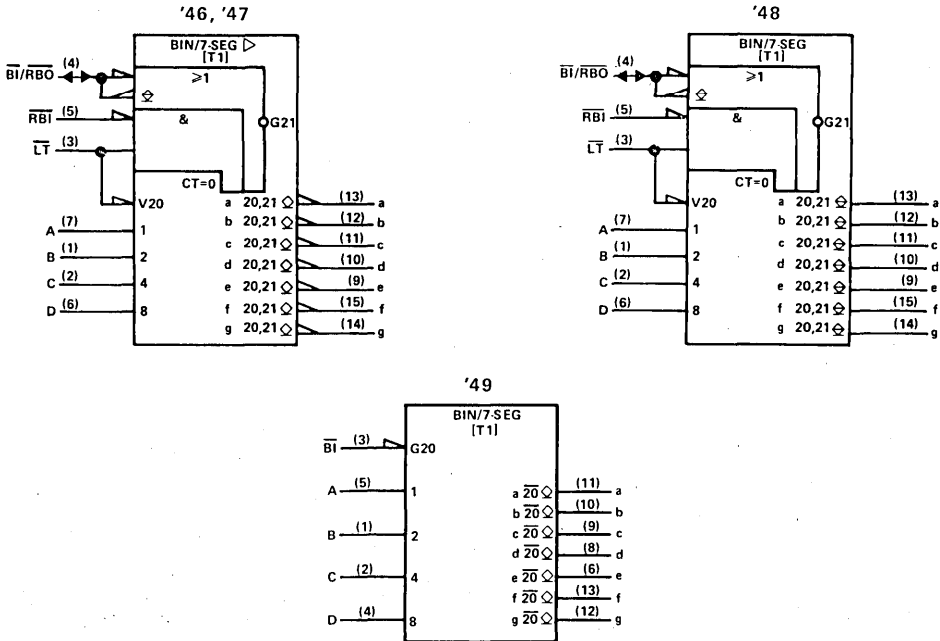

Pin numbers shown on logic notation are for D, J or N packages.

TYPES SN5446A, '47A, '48, '49, SN54L46, 'L47, SN54LS47, 'LS48, 'LS49, SN7446A, '47A, '48, SN74LS47, 'LS48, 'LS49 BCD-TO-SEVEN-SEGMENT DECODERS/DRIVERS

description

The '46A, 'L46, '47A, 'L47, and 'LS47 feature active-low outputs designed for driving common-anode VLEDs or incandescent indicators directly, and the '48, '49, 'LS48, 'LS49 feature active-high outputs for driving lamp buffers or common-cathode VLEDs. All of the circuits except '49 and 'LS49 have full ripple-blanking input/output controls and a lamp test input. The '49 and 'LS49 circuits incorporate a direct blanking input. Segment identification and resultant displays are shown below. Display patterns for BCD input counts above 9 are unique symbols to authenticate input conditions.

The '46A, '47A, '48, 'L46, 'L47, 'LS47, and 'LS48 circuits incorporate automatic leading and/or trailing-edge zero-blanking control ($\overline{\text{RBI}}$ and $\overline{\text{RBO}}$). Lamp test (LT) of these types may be performed at any time when the BI/RBO node is at a high level. All types (including the '49 and 'LS49) contain an overriding blanking input ($\overline{\text{BI}}$) which can be used to control the lamp intensity by pulsing or to inhibit the outputs. Inputs and outputs are entirely compatible for use with TTL logic outputs.

The SN54246/SN74246 through '249 and the SN54LS247/SN74LS247 through 'LS249 compose the \square and the \square with tails and have been designed to offer the designer a choice between two indicator fonts. The SN54249/SN74249 and SN54LS249/SN74LS249 are 16-pin versions of the 14-pin SN5449 and 'LS49. Included in the '249 circuit and 'LS249 circuits are the full functional capability for lamp test and ripple blanking, which is not available in the '49 or 'LS49 circuit.

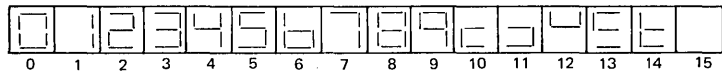
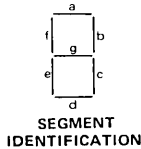

NUMERICAL DESIGNATIONS AND RESULTANT DISPLAYS

'46A, '47A, 'L46, 'L47, 'LS47 FUNCTION TABLE

DECIMAL OR FUNCTION	INPUTS						$\overline{\text{BI/RBO}}^\dagger$	OUTPUTS							NOTE
	$\overline{\text{LT}}$	$\overline{\text{RBI}}$	D	C	B	A		a	b	c	d	e	f	g	
0	H	H	L	L	L	L	H	ON	ON	ON	ON	ON	ON	OFF	OFF
1	H	X	L	L	L	H	H	OFF	ON	ON	OFF	OFF	OFF	OFF	OFF
2	H	X	L	L	H	L	H	ON	ON	OFF	ON	ON	OFF	OFF	ON
3	H	X	L	L	H	H	H	ON	ON	ON	ON	ON	OFF	OFF	ON
4	H	X	L	H	L	L	H	OFF	ON	ON	OFF	OFF	ON	ON	ON
5	H	X	L	H	L	H	H	ON	OFF	ON	ON	OFF	ON	ON	ON
6	H	X	L	H	H	L	H	OFF	OFF	ON	ON	ON	ON	ON	ON
7	H	X	L	H	H	H	H	ON	ON	ON	OFF	OFF	OFF	OFF	OFF
8	H	X	H	L	L	L	H	ON	ON	ON	ON	ON	ON	ON	ON
9	H	X	H	L	L	H	H	ON	ON	ON	OFF	OFF	ON	ON	ON
10	H	X	H	L	H	L	H	OFF	OFF	OFF	ON	ON	OFF	ON	ON
11	H	X	H	L	H	H	H	OFF	OFF	ON	ON	OFF	OFF	ON	ON
12	H	X	H	H	L	L	H	OFF	ON	OFF	OFF	OFF	ON	ON	ON
13	H	X	H	H	L	H	H	ON	OFF	OFF	ON	OFF	ON	ON	ON
14	H	X	H	H	H	L	H	OFF	OFF	OFF	ON	ON	ON	ON	ON
15	H	X	H	H	H	H	H	OFF	OFF	OFF	OFF	OFF	OFF	OFF	OFF
BI	X	X	X	X	X	X	L	OFF	OFF	OFF	OFF	OFF	OFF	OFF	2
RBI	H	L	L	L	L	L	L	OFF	OFF	OFF	OFF	OFF	OFF	OFF	3
LT	L	X	X	X	X	X	H	ON	ON	ON	ON	ON	ON	ON	4

H = high level, L = low level, X = irrelevant

- NOTES: 1. The blanking input ($\overline{\text{BI}}$) must be open or held at a high logic level when output functions 0 through 15 are desired. The ripple blanking input ($\overline{\text{RBI}}$) must be open or high if blanking of a decimal zero is not desired.
2. When a low logic level is applied directly to the blanking input ($\overline{\text{BI}}$), all segment outputs are off regardless of the level of any other input.
3. When ripple-blanking input ($\overline{\text{RBI}}$) and inputs A, B, C, and D are at a low level with the lamp test input high, all segment outputs go off and the ripple-blanking output ($\overline{\text{RBO}}$) goes to a low level (response condition).
4. When the blanking input/ripple blanking output ($\overline{\text{BI/RBO}}$) is open or held high and a low is applied to the lamp-test input, all segment outputs are on.

[†] $\overline{\text{BI/RBO}}$ is wire AND logic serving as blanking input ($\overline{\text{BI}}$) and/or ripple-blanking output ($\overline{\text{RBO}}$).

3
TTL DEVICES

TYPES SN5446A, '47A, '48, '49, SN54L46, 'L47, SN54LS47, 'LS48, 'LS49,
SN7446A, '47A, '48, SN74LS47, 'LS48, 'LS49
BCD-TO-SEVEN-SEGMENT DECODERS/DRIVERS

'48, 'LS48
FUNCTION TABLE

DECIMAL OR FUNCTION	INPUTS						$\overline{BI}/\overline{RBO}^\dagger$	OUTPUTS							NOTE
	\overline{LT}	\overline{RBI}	D	C	B	A		a	b	c	d	e	f	g	
0	H	H	L	L	L	L	H	H	H	H	H	H	H	L	1
1	H	X	L	L	L	H	H	L	H	H	L	L	L	L	
2	H	X	L	L	H	L	H	H	H	L	H	H	L	H	
3	H	X	L	L	H	H	H	H	H	H	H	L	L	H	
4	H	X	L	H	L	L	H	L	H	H	L	L	H	H	
5	H	X	L	H	L	H	H	H	L	H	H	L	H	H	
6	H	X	L	H	H	L	H	L	L	H	H	H	H	H	
7	H	X	L	H	H	H	H	H	H	H	L	L	L	L	
8	H	X	H	L	L	L	H	H	H	H	H	L	L	H	
9	H	X	H	L	L	H	H	H	H	H	L	L	H	H	
10	H	X	H	L	H	L	H	L	L	L	H	H	L	H	
11	H	X	H	L	H	H	H	L	L	H	H	L	L	H	
12	H	X	H	H	L	L	H	L	H	L	L	L	H	H	
13	H	X	H	H	L	H	H	H	L	L	H	L	H	H	
14	H	X	H	H	H	L	H	L	L	L	H	H	H	H	
15	H	X	H	H	H	H	H	L	L	L	L	L	L	L	
BI	X	X	X	X	X	X	L	L	L	L	L	L	L	L	2
RBI	H	L	L	L	L	L	L	L	L	L	L	L	L	L	3
LT	L	X	X	X	X	X	H	H	H	H	H	H	H	H	4

H = high level, L = low level, X = irrelevant

- NOTES: 1. The blanking input (\overline{BI}) must be open or held at a high logic level when output functions 0 through 15 are desired. The ripple-blanking input (\overline{RBI}) must be open or high, if blanking of a decimal zero is not desired.
2. When a low logic level is applied directly to the blanking input (\overline{BI}), all segment outputs are low regardless of the level of any other input.
3. When ripple-blanking input (\overline{RBI}) and inputs A, B, C, and D are at a low level with the lamp-test input high, all segment outputs go low and the ripple-blanking output (\overline{RBO}) goes to a low level (response condition).
4. When the blanking input/ripple-blanking output ($\overline{BI}/\overline{RBO}$) is open or held high and a low is applied to the lamp-test input, all segment outputs are high.

$^\dagger \overline{BI}/\overline{RBO}$ is wire-AND logic serving as blanking input (\overline{BI}) and/or ripple-blanking output (\overline{RBO}).

'49, 'LS49
FUNCTION TABLE

DECIMAL OR FUNCTION	INPUTS						OUTPUTS							NOTE
	D	C	B	A	\overline{BI}	a	b	c	d	e	f	g		
0	L	L	L	L	H	H	H	H	H	H	H	L	1	
1	L	L	L	H	H	L	H	H	L	L	L	L		
2	L	L	H	L	H	H	H	L	H	H	L	H		
3	L	L	H	H	H	H	H	H	H	L	L	H		
4	L	H	L	L	H	L	H	H	L	L	H	H		
5	L	H	L	H	H	H	L	H	H	L	H	H		
6	L	H	H	L	H	L	L	H	H	H	H	H		
7	L	H	H	H	H	H	H	H	H	L	L	L		
8	H	L	L	L	H	H	H	H	H	H	H	H		
9	H	L	L	H	H	H	H	H	L	L	H	H		
10	H	L	H	L	H	L	L	L	H	H	L	H		
11	H	L	H	H	H	L	L	H	H	L	L	H		
12	H	H	L	L	H	L	H	L	L	L	H	H		
13	H	H	L	H	H	H	L	L	L	H	L	H		
14	H	H	H	L	H	L	L	L	L	H	H	H		
15	H	H	H	H	H	L	L	L	L	L	L	L		
BI	X	X	X	X	L	L	L	L	L	L	L	L	2	

H = high level, L = low level, X = irrelevant

- NOTES: 1. The blanking input (\overline{BI}) must be open or held at a high logic level when output functions 0 through 15 are desired.
2. When a low logic level is applied directly to the blanking input (\overline{BI}), all segment outputs are low regardless of the level of any other input.

TYPES SN5446A, '47A, '48, SN54L46, 'L47, SN54LS47, 'LS48,
SN7446A, '74A, '48, SN74LS47, 'LS48,
BCD-TO-SEVEN-SEGMENT DECODERS/DRIVERS

logic diagrams

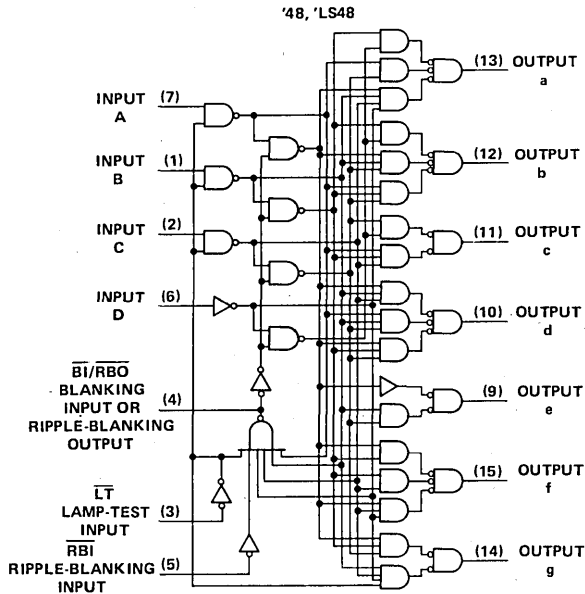
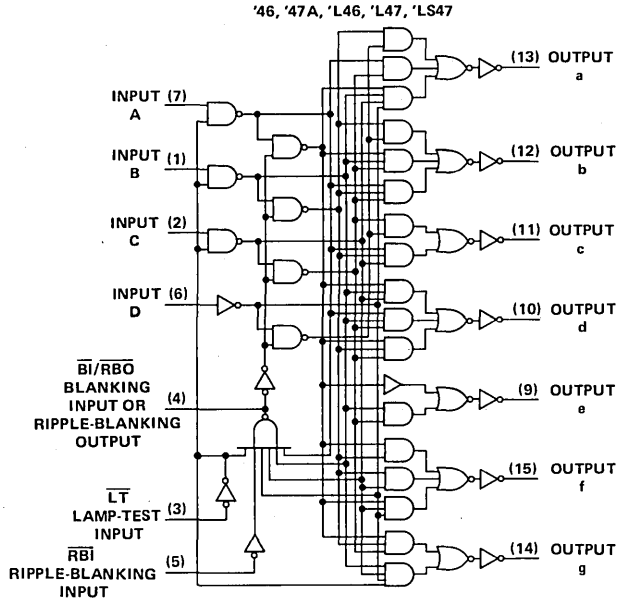

Pin numbers shown on logic notation are for D, J or N packages.

TYPES SN5449, SN54LS49, SN74LS49
BCD-TO-SEVEN-SEGMENT DECODERS/DRIVERS

logic diagrams (continued)

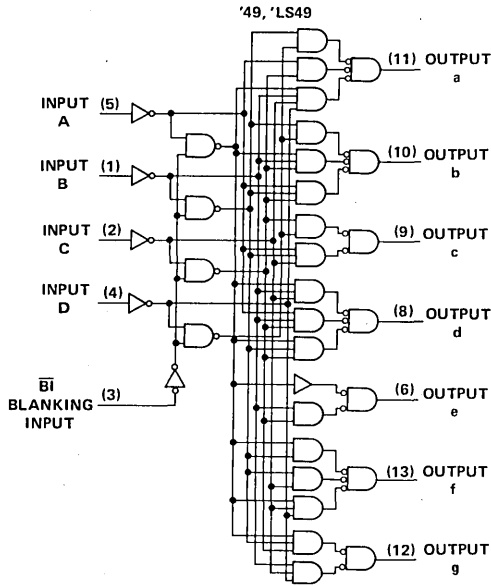

Pin numbers shown on logic notation are for D, J or N packages.

3

TTL DEVICES

TYPES SN5446A, '47A, '48, '49, SN54L46, 'L47,
SN7446A, '47A, '48
BCD-TO-SEVEN-SEGMENT DECODERS/DRIVERS

schematics of inputs and outputs

'46A, '47A, '48, '49, 'L46, 'L47

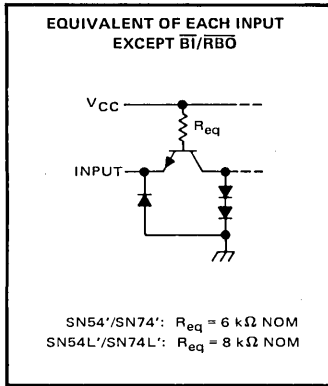

'46A, '47A, '48

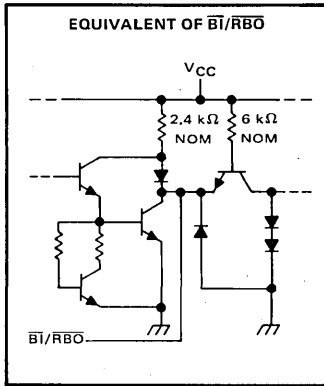

'L46, 'L47

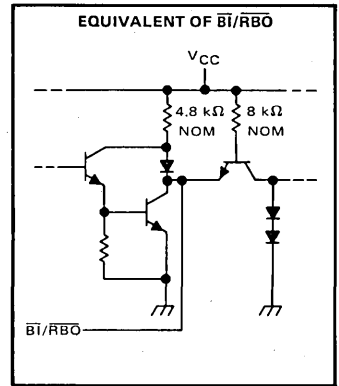

'46A, '47A

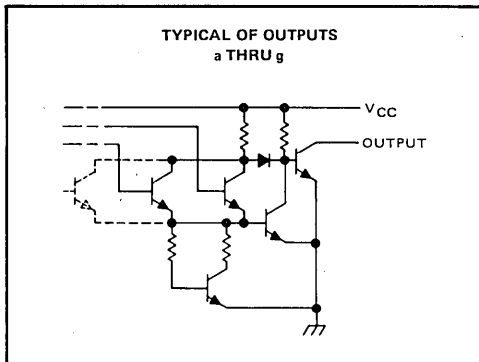

'L46, 'L47

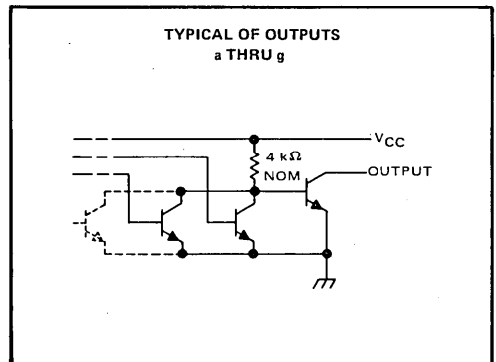

'48

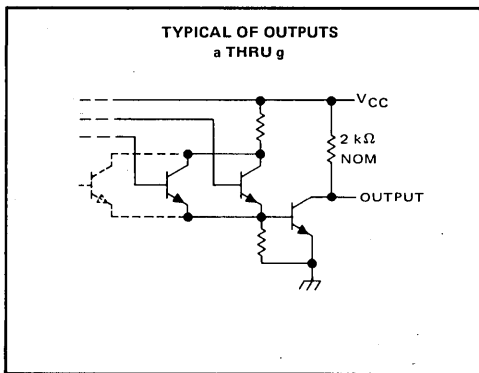

'49

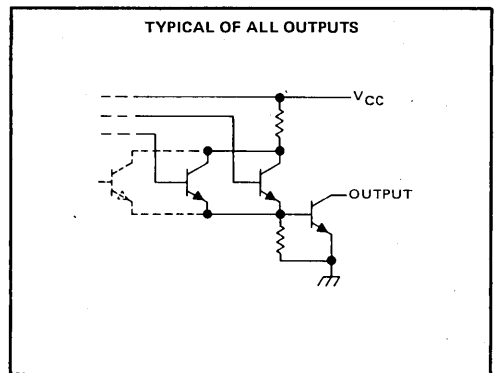

TYPES SN54LS47, 'LS48, 'LS49, SN74LS47, 'LS48, 'LS49 BCD-TO-SEVEN-SEGMENT DECODERS/DRIVERS

schematics of inputs and outputs

'LS47, 'LS48, 'LS49

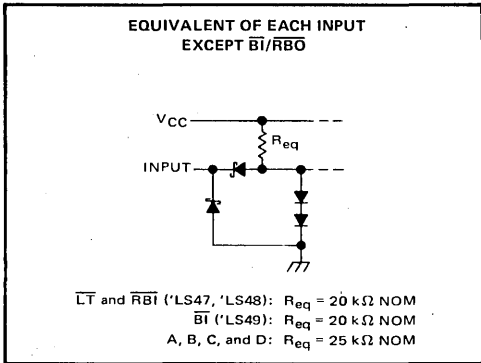

'LS47, 'LS48, 'LS49

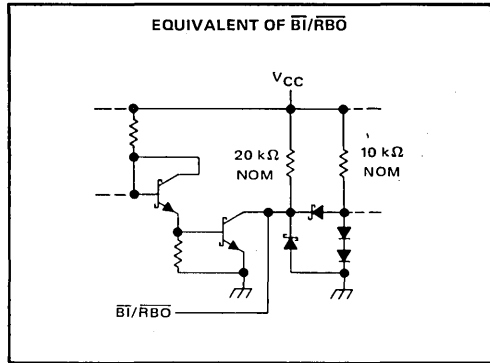

'LS47

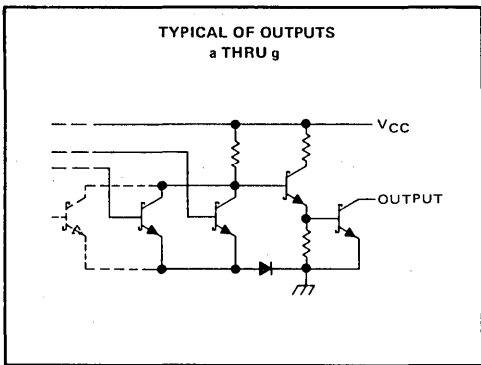

'LS48

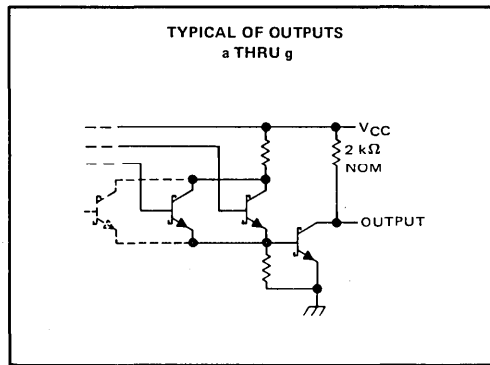

'LS49

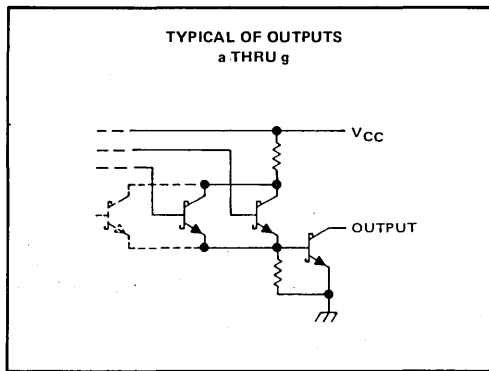

TYPES SN5446A, SN5447A, SN7446A, SN7447A BCD-TO-SEVEN-SEGMENT DECODERS/DRIVERS

absolute maximum ratings over operating free-air temperature range (unless otherwise noted)

Supply voltage, V_{CC} (see Note 1)	7 V
Input voltage	5.5 V
Current forced into any output in the off state	1 mA
Operating free-air temperature range: SN5446A, SN5447A	-55°C to 125°C
SN7446A, SN7447A	0°C to 70°C
Storage temperature range	-65°C to 150°C

NOTE 1: Voltage values are with respect to network ground terminal.

recommended operating conditions

	SN5446A			SN5447A			SN7446A			SN7447A			UNIT		
	MIN	NOM	MAX	MIN	NOM	MAX	MIN	NOM	MAX	MIN	NOM	MAX			
Supply voltage, V_{CC}	4.5	5	5.5	4.5	5	5.5	4.75	5	5.25	4.75	5	5.25	V		
Off-state output voltage, $V_{O(off)}$	a thru g			30			15			30			15	V	
On-state output current, $I_{O(on)}$	a thru g			40			40			40			40	mA	
High-level output current, I_{OH}	$\overline{BI}/R\overline{BO}$			-200			-200			-200			-200	μ A	
Low-level output current, I_{OL}	$\overline{BI}/R\overline{BO}$			8			8			8			8	mA	
Operating free-air temperature, T_A	-55			125			-55			125			0	70	°C

electrical characteristics over recommended operating free-air temperature range (unless otherwise noted)

PARAMETER		TEST CONDITIONS [†]	MIN	TYP [‡]	MAX	UNIT
V_{IH}	High-level input voltage		2			V
V_{IL}	Low-level input voltage				0.8	V
V_{IK}	Input clamp voltage	$V_{CC} = \text{MIN}, I_I = -12 \text{ mA}$			-1.5	V
V_{OH}	High-level output voltage	$\overline{BI}/R\overline{BO}$ $V_{CC} = \text{MIN}, V_{IH} = 2 \text{ V}, V_{IL} = 0.8 \text{ V}, I_{OH} = -200 \mu\text{A}$	2.4	3.7		V
V_{OL}	Low-level output voltage	$\overline{BI}/R\overline{BO}$ $V_{CC} = \text{MIN}, V_{IH} = 2 \text{ V}, V_{IL} = 0.8 \text{ V}, I_{OL} = 8 \text{ mA}$	0.27	0.4		V
$I_{O(off)}$	Off-state output current	a thru g $V_{CC} = \text{MAX}, V_{IH} = 2 \text{ V}, V_{IL} = 0.8 \text{ V}, V_{O(off)} = \text{MAX}$			250	μ A
$V_{O(on)}$	On-state output voltage	a thru g $V_{CC} = \text{MIN}, V_{IH} = 2 \text{ V}, V_{IL} = 0.8 \text{ V}, I_{O(on)} = 40 \text{ mA}$	0.3	0.4		V
I_I	Input current at maximum input voltage	Any input except $\overline{BI}/R\overline{BO}$ $V_{CC} = \text{MAX}, V_I = 5.5 \text{ V}$			1	mA
I_{IH}	High-level input current	Any input except $\overline{BI}/R\overline{BO}$ $V_{CC} = \text{MAX}, V_I = 2.4 \text{ V}$			40	μ A
I_{IL}	Low-level input current	Any input except $\overline{BI}/R\overline{BO}$ $V_{CC} = \text{MAX}, V_I = 0.4 \text{ V}$			-1.6	mA
		$\overline{BI}/R\overline{BO}$			-4	
I_{OS}	Short-circuit output current	$\overline{BI}/R\overline{BO}$ $V_{CC} = \text{MAX}$			-4	mA
I_{CC}	Supply current	$V_{CC} = \text{MAX},$ See Note 2	SN54'		64	85
			SN74'		64	103

[†]For conditions shown as MIN or MAX, use the appropriate value specified under recommended operating conditions.

[‡]All typical values are at $V_{CC} = 5 \text{ V}, T_A = 25^\circ\text{C}$.

NOTE 2: I_{CC} is measured with all outputs open and all inputs at 4.5 V.

switching characteristics, $V_{CC} = 5 \text{ V}, T_A = 25^\circ\text{C}$

PARAMETER		TEST CONDITIONS	MIN	TYP	MAX	UNIT
t_{off}	Turn-off time from A input	$C_L = 15 \text{ pF}, R_L = 120 \Omega,$ See Note 3			100	ns
t_{on}	Turn-on time from A input				100	
t_{off}	Turn-off time from \overline{BI} input				100	ns
t_{on}	Turn-on time from \overline{BI} input				100	

NOTE 3: See General Information Section for load circuits and voltage waveforms. ; t_{off} corresponds to t_{pLH} and t_{on} corresponds to t_{pHL} .

TYPES SN54L46, SN54L47 BCD-TO-SEVEN-SEGMENT DECODERS/DRIVERS

absolute maximum ratings over operating free-air temperature range (unless otherwise noted)

Supply voltage, V_{CC} (see Note 1)	7 V
Input voltage	5.5 V
Peak output current ($t_W \leq 1$ ms, duty cycle $\leq 10\%$)	200 mA
Current forced into any output in the off state	1 mA
Operating free-air temperature range: SN54L46, SN54L47	-55°C to 125°C
Storage temperature range	-65°C to 150°C

NOTE 1: Voltage values are with respect to network ground terminal.

recommended operating conditions

		SN54L46			SN54L47			UNIT
		MIN	NOM	MAX	MIN	NOM	MAX	
V_{CC}	Supply voltage	4.5	5	5.5	4.5	5	5.5	V
V_{IH}	High-level input voltage	2			2			V
V_{IL}	Low-level input voltage				0.8			V
$V_{O(off)}$	Off-state output voltage	a thru g			30			15 V
$I_{O(on)}$	On-state output current	a thru g			20			20 mA
I_{OH}	High-level output current	$\bar{B}\bar{I}/\bar{R}\bar{B}\bar{O}$			-0.1			-0.1 mA
I_{OL}	Low-level output current	$\bar{B}\bar{I}/\bar{R}\bar{B}\bar{O}$			4			4 mA
T_A	Operating free-air temperature	-55			125			-55 125 °C

electrical characteristics over recommended operating free-air temperature range (unless otherwise noted)

PARAMETER		MIN	TYP†	MAX	UNIT
V_{IK}	Any input except $\bar{B}\bar{I}/\bar{R}\bar{B}\bar{O}$	$V_{CC} = \text{MIN}, I_I = -12 \text{ mA}$		-1.5	V
V_{OH}	$\bar{B}\bar{I}/\bar{R}\bar{B}\bar{O}$	$V_{CC} = \text{MIN}, V_{IH} = 2 \text{ V}, V_{IL} = 0.8 \text{ V}, I_{OH} = -0.1 \text{ mA}$		2.4 3.4	V
V_{OL}	$\bar{B}\bar{I}/\bar{R}\bar{B}\bar{O}$	$V_{CC} = \text{MIN}, V_{IH} = 2 \text{ V}, V_{IL} = 0.8 \text{ V}, I_{OL} = 4 \text{ mA}$		0.2 0.4	V
$I_{O(off)}$	a thru g	$V_{CC} = \text{MAX}, V_{IH} = 2 \text{ V}, V_{IL} = 0.8 \text{ V}, V_{O(off)} = \text{MAX}$		250	μA
$V_{O(on)}$	a thru g	$V_{CC} = \text{MIN}, V_{IH} = 2 \text{ V}, V_{IL} = 0.8 \text{ V}, I_{O(on)} = 20 \text{ mA}$		0.3 0.4	V
I_I	Any input except $\bar{B}\bar{I}/\bar{R}\bar{B}\bar{O}$	$V_{CC} = \text{MAX}, V_I = 5.5 \text{ V}$		1	mA
I_{IH}	Any input except $\bar{B}\bar{I}/\bar{R}\bar{B}\bar{O}$	$V_{CC} = \text{MAX}, V_I = 2.4 \text{ V}$		20	μA
I_{IL}	Any input except $\bar{B}\bar{I}/\bar{R}\bar{B}\bar{O}$	$V_{CC} = \text{MAX}, V_I = 0.4 \text{ V}$		-0.8	mA
	$\bar{B}\bar{I}/\bar{R}\bar{B}\bar{O}$			-2	
I_{OS}	$\bar{B}\bar{I}/\bar{R}\bar{B}\bar{O}$	$V_{CC} = \text{MAX}$		-2	mA
I_{CC}	$V_{CC} = \text{MAX},$ See Note 2	SN54L ⁴		32 43	mA

† For conditions shown as MIN or MAX, use the appropriate value specified under recommended operating conditions.

‡ All typical values are at $V_{CC} = 5 \text{ V}, T_A = 25^\circ\text{C}$.

NOTE 2: I_{CC} is measured with all outputs open and all inputs at 4.5 V.

switching characteristics, $V_{CC} = 5 \text{ V}, T_A = 25^\circ\text{C}$

PARAMETER		TEST CONDITIONS	MIN	TYP	MAX	UNIT
t_{off}	Turn-off time from A input	$C_L = 15 \text{ pF}, R_L = 280 \Omega,$ See Note 3			200	ns
t_{on}	Turn-on time from A input				200	
t_{off}	Turn-off time from $\bar{R}\bar{B}\bar{I}$ input				200	ns
t_{on}	Turn-on time from $\bar{R}\bar{B}\bar{I}$ input				200	

NOTE 3: See General Information Section for load circuits and voltage waveforms.

3 TTL DEVICES

TYPES SN54LS47, SN74LS47 BCD-TO-SEVEN-SEGMENT DECODERS/DRIVERS

absolute maximum ratings over operating free-air temperature range (unless otherwise noted)

Supply voltage, V_{CC} (see Note 1)	7 V
Input voltage	7 V
Peak output current ($t_w \leq 1$ ms, duty cycle $\leq 10\%$)	200 mA
Current forced into any output in the off state	1 mA
Operating free-air temperature range: SN54LS47	-55°C to 125°C
SN74LS47	0°C to 70°C
Storage temperature range	-65°C to 150°C

NOTE 1: Voltage values are with respect to network ground terminal.

recommended operating conditions

	SN54LS47			SN74LS47			UNIT
	MIN	NOM	MAX	MIN	NOM	MAX	
Supply voltage, V_{CC}	4.5	5	5.5	4.75	5	5.25	V
Off-state output voltage, $V_{O(off)}$	a thru g			15			V
On-state output current, $I_{O(on)}$	a thru g			12			mA
High-level output current, I_{OH}	$\overline{BI}/\overline{R\overline{B}O}$			-50			μ A
Low-level output current, I_{OL}	$\overline{BI}/\overline{R\overline{B}O}$			1.6			3.2 mA
Operating free-air temperature, T_A	-55			125			0 70 °C

electrical characteristics over recommended operating free-air temperature range (unless otherwise noted)

PARAMETER		TEST CONDITIONS†	SN54LS47			SN74LS47			UNIT
			MIN	TYP‡	MAX	MIN	TYP‡	MAX	
V_{IH}	High-level input voltage		2			2			V
V_{IL}	Low-level input voltage					0.7			0.8 V
V_{IK}	Input clamp voltage	$V_{CC} = \text{MIN}, I_I = -18 \text{ mA}$	-1.5			-1.5			V
V_{OH}	High-level output voltage	$\overline{BI}/\overline{R\overline{B}O}$ $V_{CC} = \text{MIN}, V_{IH} = 2 \text{ V}, V_{IL} = V_{IL \text{ max}}, I_{OH} = -50 \mu\text{A}$	2.4	4.2		2.4	4.2		V
V_{OL}	Low-level output voltage	$\overline{BI}/\overline{R\overline{B}O}$ $V_{CC} = \text{MIN}, V_{IH} = 2 \text{ V}, V_{IL} = V_{IL \text{ max}}, I_{OL} = 1.6 \text{ mA}$ $I_{OL} = 3.2 \text{ mA}$	0.25 0.4			0.25 0.4			V
$I_{O(off)}$	Off-state output current	a thru g $V_{CC} = \text{MAX}, V_{IH} = 2 \text{ V}, V_{IL} = V_{IL \text{ max}}, V_{O(off)} = 15 \text{ V}$	250			250			μ A
$V_{O(on)}$	On-state output voltage	a thru g $V_{CC} = \text{MIN}, V_{IH} = 2 \text{ V}, V_{IL} = V_{IL \text{ max}}, I_{O(on)} = 12 \text{ mA}$ $I_{O(on)} = 24 \text{ mA}$	0.25 0.4			0.25 0.4			V
I_I	Input current at maximum input voltage	$V_{CC} = \text{MAX}, V_I = 7 \text{ V}$	0.1			0.1			mA
I_{IH}	High-level input current	$V_{CC} = \text{MAX}, V_I = 2.7 \text{ V}$	20			20			μ A
I_{IL}	Low-level input current	Any input except $\overline{BI}/\overline{R\overline{B}O}$	$V_{CC} = \text{MAX}, V_I = 0.4 \text{ V}$			-0.4			mA
		$\overline{BI}/\overline{R\overline{B}O}$				-1.2			-1.2
I_{OS}	Short-circuit output current	$\overline{BI}/\overline{R\overline{B}O}$ $V_{CC} = \text{MAX}$	-0.3 -2		-0.3 -2		-2		mA
I_{CC}	Supply current	$V_{CC} = \text{MAX},$ See Note 2	7 13		7 13		13		mA

† For conditions shown as MIN or MAX, use the appropriate value specified under recommended operating conditions.

‡ All typical values are at $V_{CC} = 5 \text{ V}, T_A = 25^\circ\text{C}$.

NOTE 2: I_{CC} is measured with all outputs open and all inputs at 4.5 V.

switching characteristics, $V_{CC} = 5 \text{ V}, T_A = 25^\circ\text{C}$

PARAMETER		TEST CONDITIONS	MIN	TYP	MAX	UNIT	
t_{off}	Turn-off time from A input	$C_L = 15 \text{ pF}, R_L = 665 \Omega,$ See Note 3				100	ns
t_{on}	Turn-on time from A input					100	
t_{off}	Turn-off time from $\overline{R\overline{B}I}$ input					100	ns
t_{on}	Turn-on time from $\overline{R\overline{B}I}$ input					100	

NOTE 3: See General Information Section for load circuits and voltage waveforms.

TYPES SN5448, SN7448 BCD-TO-SEVEN-SEGMENT DECODERS/DRIVERS

absolute maximum ratings over operating free-air temperature range (unless otherwise noted)

Supply voltage, V_{CC} (see Note 1)	7 V
Input voltage	5.5 V
Operating free-air temperature range: SN5448	-55°C to 125°C
SN7448	0°C to 70°C
Storage temperature range	-65°C to 150°C

NOTE 1: Voltage values are with respect to network ground terminal.

recommended operating conditions

	SN5448			SN7448			UNIT
	MIN	NOM	MAX	MIN	NOM	MAX	
Supply voltage, V_{CC}	4.5	5	5.5	4.75	5	5.25	V
High-level output current, I_{OH}	a thru g	-400		-400		μ A	
	$\overline{BI}/\overline{RBO}$	-200		-200			
Low-level output current, I_{OL}	a thru g	6.4		6.4		mA	
	$\overline{BI}/\overline{RBO}$	8		8			
Operating free-air temperature, T_A	-55		125	0	70	°C	

electrical characteristics over recommended operating free-air temperature range (unless otherwise noted)

PARAMETER		TEST CONDITIONS [†]	MIN	TYP [‡]	MAX	UNIT
V_{IH}	High-level input voltage		2			V
V_{IL}	Low-level input voltage				0.8	V
V_{IK}	Input clamp voltage	$V_{CC} = \text{MIN}, I_I = -12 \text{ mA}$			-1.5	V
V_{OH}	High-level output voltage	a thru g	$V_{CC} = \text{MIN}, V_{IH} = 2 \text{ V},$ $V_{IL} = 0.8 \text{ V}, I_{OH} = \text{MAX}$	2.4	4.2	V
		$\overline{BI}/\overline{RBO}$		2.4	3.7	
I_O	Output current	a thru g	$V_{CC} = \text{MIN}, V_O = 0.85 \text{ V},$ Input conditions as for V_{OH}	-1.3	-2	mA
V_{OL}	Low-level output voltage	$V_{CC} = \text{MIN}, V_{IH} = 2 \text{ V},$ $V_{IL} = 0.8 \text{ V}, I_{OL} = \text{MAX}$		0.27	0.4	V
I_I	Input current at maximum input voltage	Any input except $\overline{BI}/\overline{RBO}$	$V_{CC} = \text{MAX}, V_I = 5.5 \text{ V}$		1	mA
I_{IH}	High-level input current	Any input except $\overline{BI}/\overline{RBO}$	$V_{CC} = \text{MAX}, V_I = 2.4 \text{ V}$		40	μ A
I_{IL}	Low-level input current	Any input except $\overline{BI}/\overline{RBO}$	$V_{CC} = \text{MAX}, V_I = 0.4 \text{ V}$		-1.6	mA
		$\overline{BI}/\overline{RBO}$			-4	
I_{OS}	Short-circuit output current	$\overline{BI}/\overline{RBO}$	$V_{CC} = \text{MAX}$		-4	mA
I_{CC}	Supply current	$V_{CC} = \text{MAX},$ See Note 2	SN5448	53	76	mA
			SN7448	53	90	

[†] For conditions shown as MIN or MAX, use the appropriate value specified under recommended operating conditions.

[‡] All typical values are at $V_{CC} = 5 \text{ V}, T_A = 25^\circ\text{C}$.

NOTE 2: I_{CC} is measured with all outputs open and all inputs at 4.5 V.

switching characteristics, $V_{CC} = 5 \text{ V}, T_A = 25^\circ\text{C}$

PARAMETER	TEST CONDITIONS	MIN	TYP	MAX	UNIT
t_{PHL}	Propagation delay time, high-to-low-level output from A input			100	ns
t_{PLH}	Propagation delay time, low-to-high-level output from A input			100	
t_{PHL}	Propagation delay time, high-to-low-level output from $\overline{RB1}$ input	$C_L = 15 \text{ pF}, R_L = 1 \text{ k}\Omega,$ See Note 3		100	ns
t_{PLH}	Propagation delay time, low-to-high-level output from $\overline{RB1}$ input			100	

NOTE 3: See General Information Section for load circuits and voltage waveforms.

TYPES SN54LS48, SN74LS48 BCD-TO-SEVEN-SEGMENT DECODERS/DRIVERS

absolute maximum ratings over operating free-air temperature range (unless otherwise noted)

Supply voltage, V_{CC} (see Note 1)	7 V
Input voltage	7 V
Operating free-air temperature range: SN54LS48	-55°C to 125°C
SN74LS48	0°C to 70°C
Storage temperature range	-65°C to 150°C

NOTE 1: Voltage values are with respect to network ground terminal.

recommended operating conditions

	SN54LS48			SN74LS48			UNIT
	MIN	NOM	MAX	MIN	NOM	MAX	
Supply voltage, V_{CC}	4.5	5	5.5	4.75	5	5.25	V
High-level output current, I_{OH}	a thru g			-100			-100
	$\bar{B}/\bar{R}\bar{B}\bar{O}$			-50			-50
Low-level output current, I_{OL}	a thru g			2			6
	$\bar{B}/\bar{R}\bar{B}\bar{O}$			1.6			3.2
Operating free-air temperature, T_A	-55	125		0	70		°C

electrical characteristics over recommended operating free-air temperature range (unless otherwise noted)

PARAMETER		TEST CONDITIONS†	SN54LS48			SN74LS48			UNIT		
			MIN	TYP‡	MAX	MIN	TYP‡	MAX			
V_{IH}	High-level input voltage		2			2			V		
V_{IL}	Low-level input voltage		0.7			0.8			V		
V_{IK}	Input clamp voltage	$V_{CC} = \text{MIN}, I_I = -18 \text{ mA}$	-1.5			-1.5			V		
V_{OH}	High-level output voltage	$V_{CC} = \text{MIN}, V_{IH} = 2 \text{ V}, V_{IL} = V_{IL \text{ max}}, I_{OH} = \text{MAX}$	2.4	4.2		2.4	4.2		V		
I_O	Output current	$V_{CC} = \text{MIN}, V_O = 0.85 \text{ V},$ Input conditions as for V_{OH}	-1.3	-2		-1.3	-2		mA		
V_{OL}	Low-level output voltage	a thru g	$V_{CC} = \text{MIN}, V_{IH} = 2 \text{ V}, V_{IL} = V_{IL \text{ max}}, I_{OL} = 2 \text{ mA}$		0.25	0.4	0.25	0.4	V		
			$I_{OL} = 6 \text{ mA}$				0.35	0.5			
	$\bar{B}/\bar{R}\bar{B}\bar{O}$	$V_{CC} = \text{MIN}, V_{IH} = 2 \text{ V}, V_{IL} = V_{IL \text{ max}}, I_{OL} = 1.6 \text{ mA}$		0.25	0.4	0.25	0.4		V		
		$I_{OL} = 3.2 \text{ mA}$				0.35	0.5				
I_I	Input current at maximum input voltage	Any input except $\bar{B}/\bar{R}\bar{B}\bar{O}$	$V_{CC} = \text{MAX}, V_I = 7 \text{ V}$			0.1			0.1	mA	
I_{IH}	High-level input current	Any input except $\bar{B}/\bar{R}\bar{B}\bar{O}$	$V_{CC} = \text{MAX}, V_I = 2.7 \text{ V}$			20			20	μA	
I_{IL}	Low-level input current	Any input except $\bar{B}/\bar{R}\bar{B}\bar{O}$	$V_{CC} = \text{MAX}, V_I = 0.4 \text{ V}$			-0.4			-0.4	mA	
		$\bar{B}/\bar{R}\bar{B}\bar{O}$				-1.2			-1.2		
I_{OS}	Short-circuit output current	$\bar{B}/\bar{R}\bar{B}\bar{O}$	$V_{CC} = \text{MAX}$			-0.3			-2	mA	
I_{CC}	Supply current	$V_{CC} = \text{MAX},$ See Note 2	25			38			25	38	mA

† For conditions shown as MIN or MAX, use the appropriate value specified under recommended operating conditions.

‡ All typical values are at $V_{CC} = 5 \text{ V}, T_A = 25^\circ\text{C}$.

NOTE 2: I_{CC} is measured with all outputs open and all inputs at 4.5 V.

switching characteristics, $V_{CC} = 5 \text{ V}, T_A = 25^\circ\text{C}$

PARAMETER		TEST CONDITIONS	MIN	TYP	MAX	UNIT
t_{PHL}	Propagation delay time, high-to-low-level output from A input	$C_L = 15 \text{ pF}, R_L = 4 \text{ k}\Omega,$			100	ns
t_{PLH}	Propagation delay time, low-to-high-level output from A input	See Note 3			100	
t_{PHL}	Propagation delay time, high-to-low-level output from $\bar{R}\bar{B}\bar{I}$ input	$C_L = 15 \text{ pF}, R_L = 6 \text{ k}\Omega,$			100	ns
t_{PLH}	Propagation delay time, low-to-high-level output from $\bar{R}\bar{B}\bar{I}$ input	See Note 3			100	

NOTE 3: See General Information Section for load circuits and voltage waveforms.

3
TTL DEVICES

TYPES SN5449

BCD-TO-SEVEN-SEGMENT DECODER/DRIVER

absolute maximum ratings over operating free-air temperature range (unless otherwise noted)

Supply voltage, V_{CC} (see Note 1)	7 V
Input voltage	5.5 V
Current forced into any output in the off state	1 mA
Operating free-air temperature range	-55°C to 125°C
Storage temperature range	-65°C to 150°C

NOTE 1: Voltage values are with respect to network ground terminal.

recommended operating conditions

	SN5449			UNIT
	MIN	NOM	MAX	
Supply voltage, V_{CC}	4.5	5	5.5	V
High-level output voltage, V_{OH}			5.5	V
Low-level output current, I_{OL}			10	mA
Operating free-air temperature, T_A	-55		125	°C

electrical characteristics over recommended operating free-air temperature range (unless otherwise noted)

PARAMETER	TEST CONDITIONS†	SN5449		UNIT	
		MIN	TYP‡		MAX
V_{IH} High-level input voltage		2		V	
V_{IL} Low-level input voltage				0.6	V
V_{IK} Input clamp voltage	$V_{CC} = \text{MIN}, I_I = -10 \text{ mA}$			-1.5	V
I_{OH} High-level output current	$V_{CC} = \text{MIN}, V_{IH} = 2 \text{ V}, V_{IL} = 0.8 \text{ V}, V_{OH} = 5.5 \text{ V}$			250	μA
V_{OL} Low-level output voltage	$V_{CC} = \text{MIN}, V_{IH} = 2 \text{ V}, V_{IL} = 0.8 \text{ V}, I_{OL} = 10 \text{ mA}$		0.27	0.4	V
I_I Input current at maximum input voltage	$V_{CC} = \text{MAX}, V_I = 5.5 \text{ V}$			1	mA
I_{IH} High-level input current	$V_{CC} = \text{MAX}, V_I = 2.4 \text{ V}$			40	μA
I_{IL} Low-level input current	$V_{CC} = \text{MAX}, V_I = 0.4 \text{ V}$			-1.6	mA
I_{CC} Supply current	$V_{CC} = \text{MAX}, \text{ See Note 2}$		33	47	mA

† For conditions shown as MIN or MAX, use the appropriate value specified under recommended operating conditions.

‡ All typical values are at $V_{CC} = 5 \text{ V}, T_A = 25^\circ\text{C}$.

NOTE 2: I_{CC} is measured with all outputs open and all inputs at 4.5 V.

switching characteristics, $V_{CC} = 5 \text{ V}, T_A = 25^\circ\text{C}$

PARAMETER	TEST CONDITIONS	MIN	TYP	MAX	UNIT
t_{PHL} Propagation delay time, high-to-low-level output from A input	$C_L = 15 \text{ pF}, R_L = 667 \Omega,$ See Note 3			100	ns
t_{PLH} Propagation delay time, low-to-high-level output from A input				100	
t_{PHL} Propagation delay time, high-to-low-level output from RBI input				100	ns
t_{PLH} Propagation delay time, low-to-high-level output from RBI input				100	

NOTE 3: See General Information Section for load circuits and voltage waveforms.

3 TTL DEVICES

TYPES SN54LS49, SN74LS49 BCD-TO-SEVEN-SEGMENT-DECODERS/DRIVERS

absolute maximum ratings over operating free-air temperature range (unless otherwise noted)

Supply voltage, V_{CC} (see Note 1)	7 V
Input voltage	7 V
Current forced into any output in the off state	1 mA
Operating free-air temperature range: SN54LS49	-55°C to 125°C
SN74LS49	0°C to 70°C
Storage temperature range	-65°C to 150°C

NOTE 1: Voltage values are with respect to network ground terminal.

recommended operating conditions

	SN54LS49			SN74LS49			UNIT
	MIN	NOM	MAX	MIN	NOM	MAX	
Supply voltage, V_{CC}	4.5	5	5.5	4.75	5	5.25	V
High-level output voltage, V_{OH}						5.5	V
Low-level output current, I_{OL}			4			8	mA
Operating free-air temperature, T_A	-55		125	0		70	°C

electrical characteristics over recommended operating free-air temperature range (unless otherwise noted)

PARAMETER	TEST CONDITIONS†	SN54LS49			SN74LS49			UNIT
		MIN	TYP‡	MAX	MIN	TYP‡	MAX	
V_{IH} High-level input voltage		2			2			V
V_{IL} Low-level input voltage				0.7			0.8	V
V_{IK} Input clamp voltage	$V_{CC} = \text{MIN}, I_I = -18 \text{ mA}$			-1.5			-1.5	V
I_{OH} High-level output current	$V_{CC} = \text{MIN}, V_{IH} = 2 \text{ V}, V_{IL} = V_{IL \text{ max}}, V_{OH} = 5.5 \text{ V}$			250			250	μA
V_{OL} Low-level output voltage	$V_{CC} = \text{MIN}, V_{IH} = 2 \text{ V}, V_{IL} = V_{IL \text{ max}}, I_{OL} = 4 \text{ mA}$		0.25	0.4		0.25	0.4	V
	$V_{CC} = \text{MIN}, V_{IH} = 2 \text{ V}, V_{IL} = V_{IL \text{ max}}, I_{OL} = 8 \text{ mA}$					0.35	0.5	
I_I Input current at maximum input voltage	$V_{CC} = \text{MAX}, V_I = 7 \text{ V}$			0.1			0.1	mA
I_{IH} High-level input current	$V_{CC} = \text{MAX}, V_I = 2.7 \text{ V}$			20			20	μA
I_{IL} Low-level input current	$V_{CC} = \text{MAX}, V_I = 0.4 \text{ V}$			-0.4			-0.4	mA
I_{CC} Supply current	$V_{CC} = \text{MAX},$ See Note 2		8	15		8	15	mA

† For conditions shown as MIN or MAX, use the appropriate value specified under recommended operating conditions.

‡ All typical values are at $V_{CC} = 5 \text{ V}, T_A = 25^\circ\text{C}$.

NOTE 2: I_{CC} is measured with all outputs open and all inputs at 4.5 V.

switching characteristics, $V_{CC} = 5 \text{ V}, T_A = 25^\circ\text{C}$

PARAMETER	TEST CONDITIONS	MIN	TYP	MAX	UNIT
t_{PHL} Propagation delay time, high-to-low-level output from A input	$C_L = 15 \text{ pF}, R_L = 2 \text{ k}\Omega,$			100	ns
t_{PLH} Propagation delay time, low-to-high-level output from A input	See Note 3			100	
t_{PHL} Propagation delay time, high-to-low-level output from $\overline{RB1}$ input	$C_L = 15 \text{ pF}, R_L = 6 \text{ k}\Omega,$			100	ns
t_{PLH} Propagation delay time, low-to-high-level output from $\overline{RB1}$ input	See Note 3			100	

NOTE 3: See General Information Section for load circuits and voltage waveforms.

3

TTL DEVICES

TYPES SN5450, SN54H50, SN7450, SN74H50

DUAL 2-WIDE 2-INPUT AND-OR-INVERT GATES (ONE GATE EXPANDABLE)

REVISED DECEMBER 1983

- Package Options Include Plastic and Ceramic DIPs
- Dependable Texas Instruments Quality and Reliability

description

These devices contain two independent 2-wide 2-input AND-OR-INVERT gates with one gate expandable. They perform the Boolean function $Y = \overline{AB + CD + X}$ with X = output of SN5460/SN7460 for the SN5450/SN7450 and X = output of SN54H60/SN74H60 or SN54H62/SH74H62 for the SN54H50/SH74H50.

The SN5450 and SN54H50 are characterized for operation over the full military temperature range of -55°C to 125°C . The SN7450 and SN74H50 are characterized for operation from 0°C to 70°C .

logic diagram

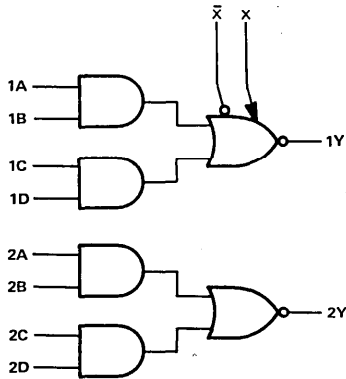

SN5450, SN54H50 . . . J PACKAGE
SN7450, SN74H50 . . . J OR N PACKAGE
(TOP VIEW)

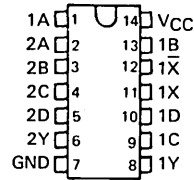

SN5450, SN54H50 . . . W PACKAGE
(TOP VIEW)

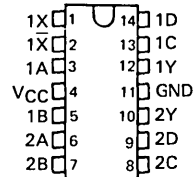

PRODUCTION DATA

This document contains information current as of publication date. Products conform to specifications per the terms of Texas Instruments standard warranty. Production processing does not necessarily include testing of all parameters.

TYPES SN5450, SN54H50, SN7450, SN74H50

DUAL 2-WIDE 2-INPUT AND-OR-INVERT GATES (ONE GATE EXPANDABLE)

schematic

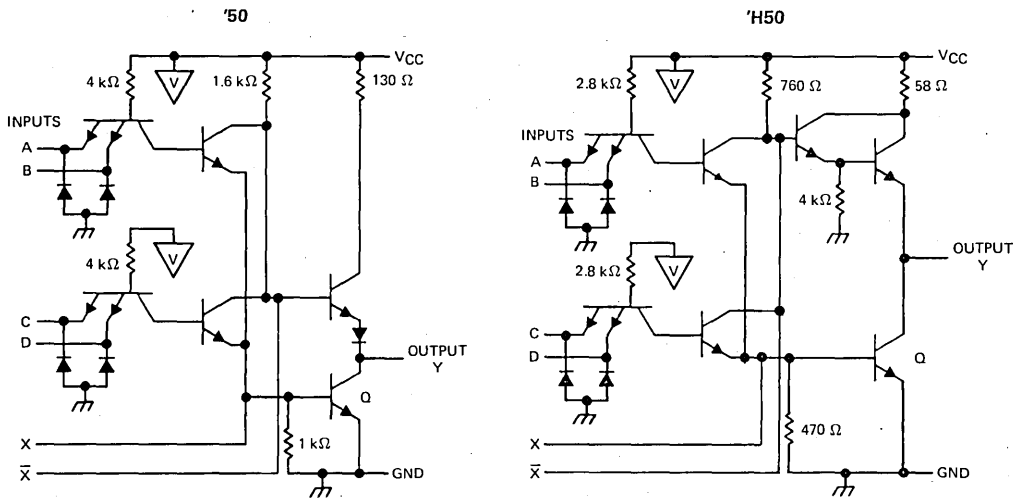

Resistor values shown are nominal.
If expander is not used, leave X and \bar{X} open.

absolute maximum ratings over operating free-air temperature range (unless otherwise noted)

Supply voltage, V_{CC} (see Note 1)	7 V
Input voltage	5.5 V
Operating free-air temperature range: SN54'	- 55°C to 125°C
SN74'	0°C to 70°C
Storage temperature range	- 65°C to 150°C

NOTE 1: Voltage values are with respect to network ground terminal.



TTL DEVICES

TYPES SN5450, SN7450

DUAL 2-WIDE 2-INPUT AND-OR-INVERT GATES (ONE GATE EXPANDABLE)

recommended operating conditions

	SN5450			SN7450			UNIT
	MIN	NOM	MAX	MIN	NOM	MAX	
V _{CC} Supply voltage	4.5	5	5.5	4.75	5	5.25	V
V _{IH} High-level input voltage	2			2			V
V _{IL} Low-level input voltage			0.8			0.8	V
I _{OH} High-level output current			-0.4			-0.4	mA
I _{OL} Low-level output current			16			16	mA
T _A Operating free-air temperature	-55		125	0		70	°C

electrical characteristics over recommended operating free-air temperature range (unless otherwise noted)

PARAMETER	TEST CONDITIONS†	SN5450			SN7450			UNIT
		MIN	TYP‡	MAX	MIN	TYP‡	MAX	
V _{IK}	V _{CC} = MIN, I _I = -12 mA			-1.5			-1.5	V
V _{OH}	V _{CC} = MIN, V _{IL} = 0.8 V, I _{OH} = -0.4 mA	2.4	3.4		2.4	3.4		V
V _{OL}	V _{CC} = MIN, V _{IH} = 2 V, I _{OL} = 16 mA		0.2	0.4		0.2	0.4	V
I _I	V _{CC} = MAX, V _I = 5.5 V			1			1	mA
I _{IH}	V _{CC} = MAX, V _{IH} = 2.4 V			40			40	μA
I _{IL}	V _{CC} = MAX, V _{IL} = 0.4 V			-1.6			-1.6	mA
I _{OS} §	V _{CC} = MAX	-20		-55	-18		-55	mA
I _{CCH}	V _{CC} = MAX, V _I = 0 V		4	8		4	8	mA
I _{CCL}	V _{CC} = MAX, See Note 2		7.4	14		7.4	14	mA
I _X ▲	V _X = 0.4 V, I _{OL} = 16 mA			-2.9			-3.1	mA
V _{BE(Q)} ▲	I _X + I _X = 0.41 mA, R _X = 0, I _{OL} = 16 mA			1.1				V
	I _X + I _X = 0.62 mA, R _X = 0, I _{OL} = 16 mA						1	V
V _{OH} ▲	I _X = 0.15 mA, I _X = -0.15 mA, I _{OH} = -0.4 mA	2.4	3.4					V
	I _X = 0.27 mA, I _X = -0.27 mA, I _{OH} = -0.4 mA				2.4	3.4		V
V _{OL} ▲	I _X + I _X = 0.3 mA, R _X = 138 Ω, I _{OL} = 16 mA		0.2	0.4				V
	I _X + I _X = 0.43 mA, R _X = 130 Ω, I _{OL} = 16 mA				0.2	0.4		V

† For conditions shown as MIN or MAX, use the appropriate value specified under recommended operating conditions.

‡ All typical values are at V_{CC} = 5 V, T_A = 25°C.

§ Not more than one output should be shorted at a time.

▲ Using expander inputs, V_{CC} = MIN, T_A = MIN, except typical values.

NOTE 2: All inputs of one AND gate at 4.5 V, all others at GND.

switching characteristics, V_{CC} = 5 V, T_A = 25°C (see note 3)

PARAMETER	FROM (INPUT)	TO (OUTPUT)	TEST CONDITIONS	MIN	TYP	MAX	UNIT
t _{PLH}	Any	Y	R _L = 400 Ω, C _L = 15 pF		13	22	ns
t _{PHL}			Expander pins open		8	15	ns

NOTE 3: See General Information Section for load circuits and voltage waveforms.

TYPES SN54H50, SN74H50
DUAL 2-WIDE 2-INPUT AND-OR-INVERT GATES (ONE GATE EXPANDABLE)

recommended operating conditions

	SN54H50			SN74H50			UNIT
	MIN	NOM	MAX	MIN	NOM	MAX	
V _{CC} Supply voltage	4.5	5	5.5	4.75	5	5.25	V
V _{IH} High-level input voltage	2			2			V
V _{IL} Low-level input voltage	0.8			0.8			V
I _{OH} High-level output current	-0.5			-0.5			mA
I _{OL} Low-level output current	20			20			mA
T _A Operating free-air temperature	-55			125			0 70 °C

electrical characteristics over recommended operating free-air temperature range (unless otherwise noted)

PARAMETER	TEST CONDITIONS†	SN54H50		SN74H50		UNIT
		MIN	TYP‡	MAX	MIN	
V _{IK}	V _{CC} = MIN, I _I = -8 mA	-1.5		-1.5		V
V _{OH}	V _{CC} = MIN, V _{IL} = 0.8 V, I _{OH} = -0.5 mA	2.4	3.4	2.4	3.4	V
V _{OL}	V _{CC} = MIN, V _{IH} = 2 V, I _{OL} = 20 mA	0.2	0.4	0.2	0.4	V
I _I	V _{CC} = MAX, V _I = 5.5 V	1		1		mA
I _{IH}	V _{CC} = MAX, V _{IH} = 2.4 V	50		50		µA
I _{IL}	V _{CC} = MAX, V _{IL} = 0.4 V	-2		-2		mA
I _{OS} §	V _{CC} = MAX	-40	-100	-40	-100	mA
I _{CCH}	V _{CC} = MAX, V _I = 0 V	8.2	12.8	8.2	12.8	mA
I _{CCL}	V _{CC} = MAX, See Note 2	15.2	24	15.2	24	mA
I _X ▲	V _X = 1.4 V, I _X = 0, I _{OL} = 0	-5.85		-6.3		mA
V _{BE(O)} ▲	I _X + I _X = 0.7 mA, R _X X = 0, I _{OL} = 20 mA	1.1				V
	I _X + I _X = 1.1 mA, R _X X = 0, I _{OL} = 20 mA			1		
V _{OH} ▲	I _X = 0.32 mA, I _X = -0.32 mA, I _{OH} = -0.5 mA	2.4	3.4			V
	I _X = 0.57 mA, I _X = -0.57 mA, I _{OH} = -0.5 mA			2.4	3.4	
V _{OL} ▲	I _X + I _X = 0.47 mA, R _X X = 68 Ω, I _{OL} = 20 mA	0.2	0.4			V
	I _X + I _X = 0.6 mA, R _X X = 63 Ω, I _{OL} = 20 mA			0.2	0.4	

† For conditions shown as MIN or MAX, use the appropriate value specified under recommended operating conditions.

‡ All typical values are at V_{CC} = 5 V, T_A = 25° C.

§ Not more than one output should be shorted at a time, and duration of the short circuit should not exceed one second.

▲ Using expander inputs, V_{CC} = MIN, T_A = MIN, except typical values.

NOTE 2: All inputs of one AND gate at 4.5 V, all others at GND.

switching characteristics, V_{CC} = 5 V, T_A = 25° C (see note 3)

PARAMETER	FROM (INPUT)	TO (OUTPUT)	TEST CONDITIONS	MIN	TYP	MAX	UNIT
t _{PLH}	Any	Y	R _L = 280 Ω, Expander pins open, C _L = 25 pF	6.8	11		ns
t _{PHL}				6.2	11		ns
t _{PLH}			R _L = 280 Ω, Ground to X, C _L = 25 pF, C = 15 pF	11			ns
t _{PHL}				7.4			ns

NOTE 3: See General Information Section for load circuits and voltage waveforms.

3

TTL DEVICES

TYPES SN5451, SN54H51, SN54L51, SN54LS51, SN54S51, SN7451, SN74H51, SN74LS51, SN74S51 AND-OR-INVERT GATES

REVISED DECEMBER 1983

- Package Options Include Both Plastic and Ceramic Chip Carriers in Addition to Plastic and Ceramic DIPs
- Dependable Texas Instruments Quality and Reliability

description

The '51, 'H51, and 'S51 contain two independent 2-wide 2-input AND-OR-INVERT gates. They perform the Boolean function $Y = AB + CD$.

The 'L51 and 'LS51 contain one 2-wide 3-input and one 2-wide 2-input AND-OR-INVERT gates. They perform the Boolean functions $1Y = (1A \cdot 1B \cdot 1C) + (1D \cdot 1E \cdot 1F)$ and $2Y = (2A \cdot 2B) + (2C \cdot 2D)$.

The SN5451, SN54H51, SN54L51, SN54LS51 and SN54S51 are characterized for operation over the full military temperature range of -55°C to 125°C . The SN7451, SN74H51, SN74LS51 and SN74S51 are characterized for operation from 0°C to 70°C .

logic diagrams

'51, 'H51, 'S51

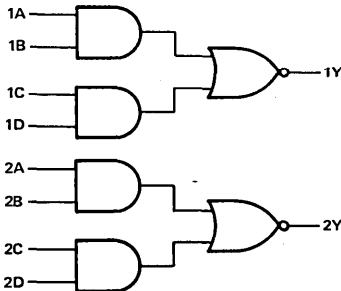

'L51, 'LS51

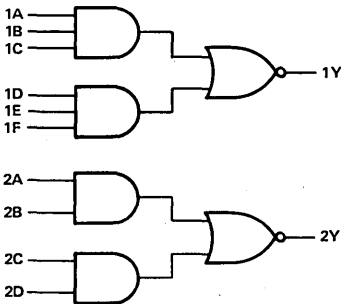

SN5451, SN54H51 ... J PACKAGE
SN54S51 ... J OR W PACKAGE
SN7451, SN74H51 ... J OR N PACKAGE
SN74S51 ... D, J OR N PACKAGE
(TOP VIEW)

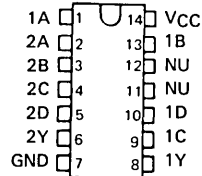

SN5451, SN54H51 ... W PACKAGE
(TOP VIEW)

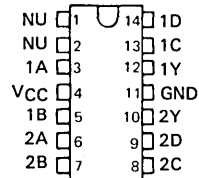

SN54L51 ... J PACKAGE
SN54LS51 ... J OR W PACKAGE
SN74LS51 ... D, J OR N PACKAGE
(TOP VIEW)

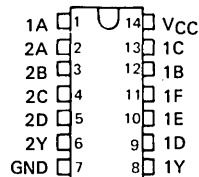

NC - No internal connection
NU - Make no external connection

PRODUCTION DATA
This document contains information current as of publication date. Products conform to specifications per the terms of Texas Instruments standard warranty. Production processing does not necessarily include testing of all parameters.

**TEXAS
INSTRUMENTS**

POST OFFICE BOX 225012 • DALLAS, TEXAS 75265

TYPES SN5451, SN54H51, SN54L51, SN7451, SN74H51 AND-OR-INVERT GATES

SN54S51 ... FK PACKAGE
SN74S51 ... FN PACKAGE
(TOP VIEW)

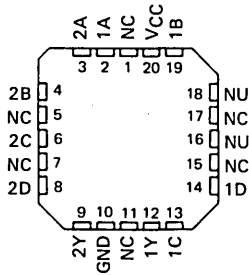

SN54LS51 ... FK PACKAGE
SN74LS51 ... FN PACKAGE
(TOP VIEW)

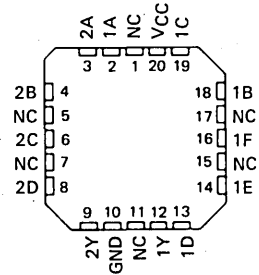

NC - No internal connection
NU - Make no external connection

schematics

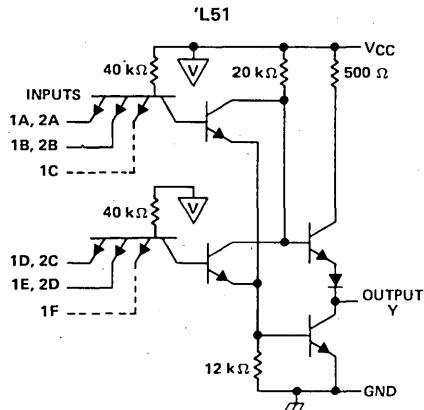
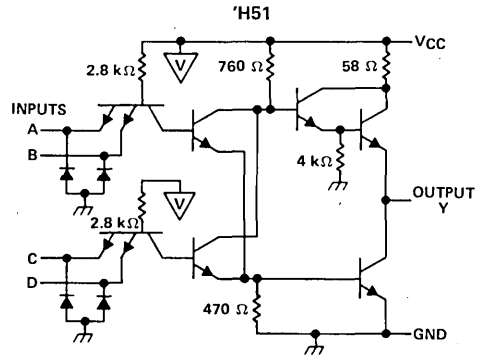
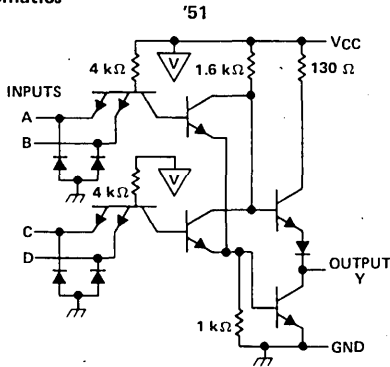

3

TTL DEVICES

TYPES SN5451, SN54H51, SN54L51, SN54LS51, SN54S51,
SN7451, SN74H51, SN74LS51, SN74S51
AND-OR-INVERT GATES

schematics

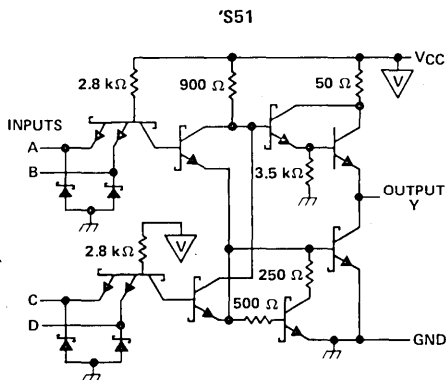
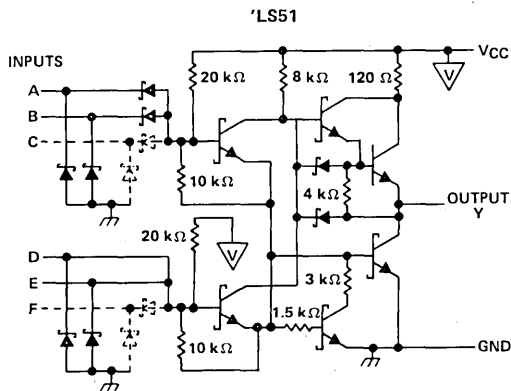

absolute maximum ratings over operating free-air temperature range (unless otherwise noted)

Supply voltage, V_{CC} (see Note 1): '51, 'H51, 'LS51, 'S51	7 V
'L51	8 V
Input voltage: '51, 'H51, 'L51, 'S51	5.5 V
'LS51	7 V
Operating free-air temperature range: SN54'	-55°C to 125°C
SN74'	0°C to 70°C
Storage temperature range	-65°C to 150°C

NOTE 1: Voltage values are with respect to network ground terminal.

3
TTL DEVICES

TYPES SN5451, SN7451 AND-OR-INVERT GATES

recommended operating conditions

	SN5451			SN7451			UNIT
	MIN	NOM	MAX	MIN	NOM	MAX	
V _{CC} Supply voltage	4.5	5	5.5	4.75	5	5.25	V
V _{IH} High-level input voltage	2			2			V
V _{IL} Low-level input voltage			0.8			0.8	V
I _{OH} High-level output current			-0.4			-0.4	mA
I _{OL} Low-level output current			16			16	mA
T _A Operating free-air temperature	-55		125	0		70	°C

electrical characteristics over recommended operating free-air temperature range (unless otherwise noted)

PARAMETER	TEST CONDITIONS †	SN5451			SN7451			UNIT
		MIN	TYP ‡	MAX	MIN	TYP ‡	MAX	
V _{IK}	V _{CC} = MIN, I _I = -12 mA			-1.5			-1.5	V
V _{OH}	V _{CC} = MIN, V _{IL} = 0.8 V, I _{OH} = -0.4 mA	2.4	3.4		2.4	3.4		V
V _{OL}	V _{CC} = MIN, V _{IH} = 2 V, I _{OL} = 16 mA		0.2	0.4		0.2	0.4	V
I _I	V _{CC} = MAX, V _I = 5.5 V			1			1	mA
I _{IH}	V _{CC} = MAX, V _I = 2.4 V			40			40	μA
I _{IL}	V _{CC} = MAX, V _I = 0.4 V			-1.6			-1.6	mA
I _{OS} §	V _{CC} = MAX	-20		-55	-18		-55	mA
I _{CCH}	V _{CC} = MAX, V _I = 0 V		4	8		4	8	mA
I _{CCL}	V _{CC} = MAX, See Note 2		7.4	14		7.4	14	mA

† For conditions shown as MIN or MAX, use the appropriate value specified under recommended operating conditions.

‡ All typical values are at V_{CC} = 5 V, T_A = 25°C.

§ Not more than one output should be shorted at a time.

NOTE 2: All inputs of one AND gate at 4.5 V, all others at GND.

switching characteristics, V_{CC} = 5 V, T_A = 25°C (see note 3)

PARAMETER	FROM (INPUT)	TO (OUTPUT)	TEST CONDITIONS	MIN	TYP	MAX	UNIT
t _{PLH}	Any	Y	R _L = 400 Ω, C _L = 15 pF		13	22	ns
t _{PHL}					8	15	

NOTE 3: See General Information Section for load circuits and voltage waveforms.

3

TTL DEVICES

recommended operating conditions

	SN54H51			SN74H51			UNIT
	MIN	NOM	MAX	MIN	NOM	MAX	
V _{CC} Supply voltage	4.5	5	5.5	4.75	5	5.25	V
V _{IH} High-level input voltage	2			2			V
V _{IL} Low-level input voltage			0.8			0.8	V
I _{OH} High-level output current			-0.5			-0.5	mA
I _{OL} Low-level output current			20			20	mA
T _A Operating free-air temperature	-55		125	0		70	°C

electrical characteristics over recommended operating free-air temperature range (unless otherwise noted)

PARAMETER	TEST CONDITIONS †	MIN	TYP ‡	MAX	UNIT
V _{IK}	V _{CC} = MIN, I _I = -8 mA			-1.5	V
V _{OH}	V _{CC} = MIN, V _{IIL} = 0.8 V, I _{OH} = -0.5 mA	2.4	3.4		V
V _{OL}	V _{CC} = MIN, V _{IH} = 2 V, I _{OL} = 20 mA		0.2	0.4	V
I _I	V _{CC} = MAX, V _I = 5.5 V			1	mA
I _{IH}	V _{CC} = MAX, V _I = 2.4 V			50	μA
I _{IIL}	V _{CC} = MAX, V _I = 0.4 V			-2	mA
I _{OS} §	V _{CC} = MAX	-40		-100	mA
I _{CCH}	V _{CC} = MAX, V _I = 0 V		8.2	12.8	mA
I _{CCL}	V _{CC} = MAX, See Note 2		15.2	24	mA

† For conditions shown as MIN or MAX, use the appropriate value specified under recommended operating conditions.

‡ All typical values are at V_{CC} = 5 V, T_A = 25°C.

§ Not more than one output should be shorted at a time, and the duration of the short circuit should not exceed one second.

NOTE 2: All inputs of one AND gate at 4.5 V, all others at GND.

switching characteristics, V_{CC} = 5 V, T_A = 25°C (see note 3)

PARAMETER	FROM (INPUT)	TO (OUTPUT)	TEST CONDITIONS	MIN	TYP	MAX	UNIT
t _{PLH}	Any	Y	R _L = 280 Ω, C _L = 25 pF	6.8	11		ns
t _{PHL}				6.2	11		ns

NOTE 3: See General Information Section for load circuits and voltage waveforms.

TYPE SN54L51 AND-OR-INVERT GATES

recommended operating conditions

	SN54L51			UNIT
	MIN	NOM	MAX	
V _{CC} Supply voltage	4.5	5	5.5	V
V _{IH} High-level input voltage	2			V
V _{IL} Low-level input voltage	0.7			V
I _{OH} High-level output current	-0.1			mA
I _{OL} Low-level output current	2			mA
T _A Operating free-air temperature	-55	125		°C

electrical characteristics over recommended operating free-air temperature range (unless otherwise noted)

PARAMETER	TEST CONDITIONS †	SN54L51			UNIT
		MIN	TYP ‡	MAX	
V _{OH}	V _{CC} = MIN, V _{IL} = 0.7 V, I _{OH} = -0.1 mA	2.4	3.3		V
V _{OL}	V _{CC} = MIN, V _{IH} = 2 V, I _{OL} = 2 mA	0.15		0.3	V
I _I	V _{CC} = MAX, V _I = 5.5 V	0.1			mA
I _{IH}	V _{CC} = MAX, V _I = 2.4 V	10			μA
I _{IL}	V _{CC} = MAX, V _I = 0.3 V	-0.18			mA
I _{OS} §	V _{CC} = MAX	-3	-15		mA
I _{CCH}	V _{CC} = MAX, V _I = 0 V	0.44		0.8	mA
I _{CCL}	V _{CC} = MAX, See Note 2	0.76		1.3	mA

† For conditions shown as MIN or MAX, use the appropriate value specified under recommended operating conditions.

‡ All typical values are at V_{CC} = 5 V, T_A = 25°C.

§ Not more than one output should be shorted at a time.

NOTE 2: All inputs of one AND gate at 4.5 V, all others at GND.

switching characteristics, V_{CC} = 5 V, T_A = 25°C (see note 3)

PARAMETER	FROM (INPUT)	TO (OUTPUT)	TEST CONDITIONS	MIN	TYP	MAX	UNIT
t _{PLH}	Any	Y	R _L = 4 kΩ, C _L = 50 pF		50	90	ns
t _{PHL}					35	60	ns

NOTE 3: See General Information Section for load circuits and voltage waveforms.

TYPES SN54LS51, SN74LS51 AND-OR-INVERT GATES

recommended operating conditions

	SN54LS51			SN74LS51			UNIT
	MIN	NOM	MAX	MIN	NOM	MAX	
V _{CC} Supply voltage	4.5	5	5.5	4.75	5	5.25	V
V _{IH} High-level input voltage	2			2			V
V _{IL} Low-level input voltage			0.7			0.8	V
I _{OH} High-level output current			-0.4			-0.4	mA
I _{OL} Low-level output current			4			8	mA
T _A Operating free-air temperature	-55		125	0		70	°C

electrical characteristics over recommended operating free-air temperature range (unless otherwise noted)

PARAMETER	TEST CONDITIONS †	SN54LS51		SN74LS51		UNIT			
		MIN	TYP ‡	MAX	MIN		TYP ‡	MAX	
V _{IK}	V _{CC} = MIN, I _I = -18 mA			-1.5		-1.5	V		
V _{OH}	V _{CC} = MIN, V _{IL} = MAX, I _{OH} = -0.4 mA	2.5	3.4		2.7	3.4	V		
V _{OL}	V _{CC} = MIN, V _{IH} = 2 V, I _{OL} = 4 mA		0.25	0.4		0.25	0.4	V	
	V _{CC} = MIN, V _{IH} = 2 V, I _{OL} = 8 mA					0.35	0.5		
I _I	V _{CC} = MAX, V _I = 7 V			0.1			0.1	mA	
I _{IH}	V _{CC} = MAX, V _I = 2.7 V			20			20	μA	
I _{IL}	V _{CC} = MAX, V _I = 0.4 V			-0.4			-0.4	mA	
I _{OS} §	V _{CC} = MAX	-20		-100	-20		-100	mA	
I _{CCH}	V _{CC} = MAX, V _I = 0 V			0.8			0.8	1.6	mA
I _{CCL}	V _{CC} = MAX, See Note 2			1.4			1.4	2.8	mA

† For conditions shown as MIN or MAX, use the appropriate value specified under recommended operating conditions.

‡ All typical values are at V_{CC} = 5 V, T_A = 25°C.

§ Not more than one output should be shorted at a time, and the duration of the short-circuit should not exceed one second.

NOTE 2: All inputs of one AND gate at 4.5 V, all others at GND.

switching characteristics, V_{CC} = 5 V, T_A = 25°C (see note 3)

PARAMETER	FROM (INPUT)	TO (OUTPUT)	TEST CONDITIONS	MIN	TYP	MAX	UNIT
t _{PLH}	Any	Y	R _L = 2 kΩ, C _L = 15 pF		12	20	ns
t _{PHL}					12.5	20	ns

NOTE 3: See General Information Section for load circuits and voltage waveforms.



TTL DEVICES

TYPES SN54S51, SN74S51 AND-OR-INVERT GATES

recommended operating conditions

	SN54S51			SN74S51			UNIT
	MIN	NOM	MAX	MIN	NOM	MAX	
V _{CC} Supply voltage	4.5	5	5.5	4.75	5	5.25	V
V _{IH} High-level input voltage	2			2			V
V _{IL} Low-level input voltage			0.8			0.8	V
I _{OH} High-level output current			-1			-1	mA
I _{OL} Low-level output current			20			20	mA
T _A Operating free-air temperature	-55		125	0		70	°C

electrical characteristics over recommended operating free-air temperature range (unless otherwise noted)

PARAMETER	TEST CONDITIONS †	SN54S51			SN74S51			UNIT
		MIN	TYP ‡	MAX	MIN	TYP ‡	MAX	
V _{IK}	V _{CC} = MIN, I _I = -18 mA			-1.2			-1.2	V
V _{OH}	V _{CC} = MIN, V _{IL} = 0.8 V, I _{OH} = -1 mA	2.5	3.4		2.7	3.4		V
V _{OL}	V _{CC} = MIN, V _{IH} = 2 V, I _{OL} = 20 mA			0.5			0.5	V
I _I	V _{CC} = MAX, V _I = 5.5 V			1			1	mA
I _{IH}	V _{CC} = MAX, V _I = 2.7 V			50			50	μA
I _{IL}	V _{CC} = MAX, V _I = 0.5 V			-2			-2	mA
I _{OS} §	V _{CC} = MAX	-40		-100	-40		-100	mA
I _{CCH}	V _{CC} = MAX, V _I = 0 V		8.2	17.8		8.2	17.8	mA
I _{CCL}	V _{CC} = MAX, See Note 2		13.6	.22		13.6	22	mA

† For conditions shown as MIN or MAX, use the appropriate value specified under recommended operating conditions.

‡ All typical values are at V_{CC} = 5 V, T_A = 25° C.

§ Not more than one output should be shorted at a time, and the duration of the short-circuit should not exceed one second.

NOTE 2: All inputs of one AND gate at 4.5 V, all others at GND.

switching characteristics, V_{CC} = 5 V, T_A = 25° C (see note 3)

PARAMETER	FROM (INPUT)	TO (OUTPUT)	TEST CONDITIONS		MIN	TYP	MAX	UNIT
t _{PLH}	Any	Y	R _L = 280 Ω,	C _L = 15 pF	3.5	5.5		ns
t _{PHL}					3.5	5.5		ns
t _{PLH}			R _L = 280 Ω,	C _L = 50 pF	5			ns
t _{PHL}					5.5			ns

NOTE 3: See General Information Section for load circuits and voltage waveforms.

3

TTL DEVICES

TYPES SN54H52, SN74H52 EXPANDABLE 4-WIDE AND-OR GATES

REVISED DECEMBER 1983

- Package Options Include Plastic and Ceramic DIPs
- Dependable Texas Instruments Quality and Reliability

description

These devices contain expandable 4-wide AND-OR gates. In the J and N packages they perform the Boolean function $Y = AB + CDE + FG + HI + X$ and in the W package $Y = AB + CD + EF + GHI + X$ with $X =$ output of SN54H61/SN74H61.

The SN54H52 is characterized for operation over the full military temperature range of -55°C to 125°C . The SN74H52 is characterized for operation from 0°C to 70°C .

logic diagrams

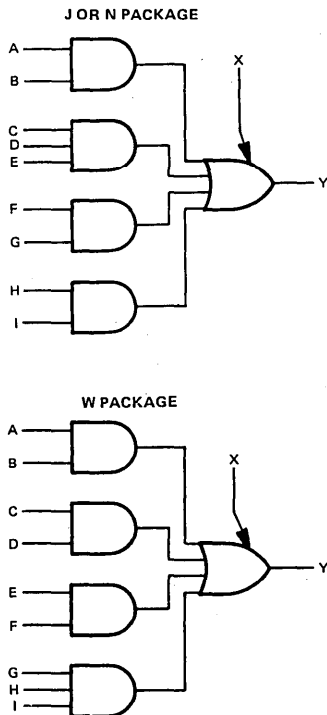

SN54H52 ... J PACKAGE
SN74H52 ... J OR N PACKAGE
(TOP VIEW)

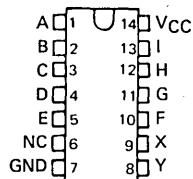

SN54H52 ... W PACKAGE
(TOP VIEW)

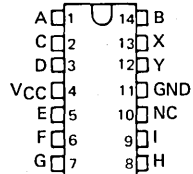

NC - No internal connection

3

TTL DEVICES

PRODUCTION DATA
This document contains information current as of publication date. Products conform to specifications per the terms of Texas Instruments standard warranty. Production processing does not necessarily include testing of all parameters.

TEXAS
INSTRUMENTS

POST OFFICE BOX 225012 • DALLAS, TEXAS 75265

3-221

TYPES SN54H52, SN74H52 EXPANDABLE 4-WIDE AND-OR GATES

schematic

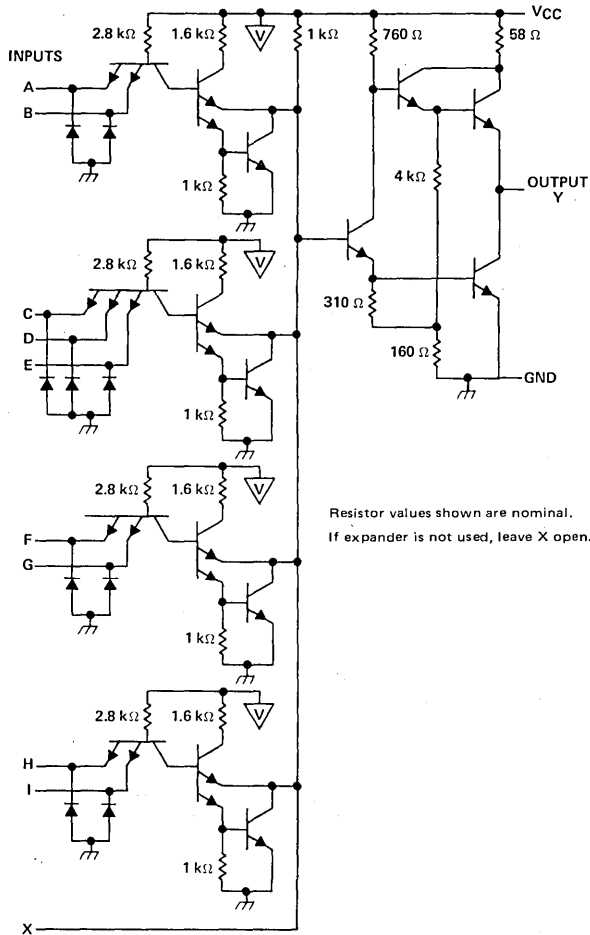

Resistor values shown are nominal.
If expander is not used, leave X open.

3 TTL DEVICES

absolute maximum ratings over operating free-air temperature range (unless otherwise noted)

Supply voltage, V_{CC} (see Note 1)	7 V
Input voltage	5.5 V
Operating free-air temperature range: SN54H52	-55°C to 125°C
SN74H52	0°C to 70°C
Storage temperature range	-65°C to 150°C

NOTE 1: Voltage values are with respect to network ground terminal.

TYPES SN54H52, SN74H52 EXPANDABLE 4-WIDE AND-OR GATES

recommended operating conditions

	SN54H52			SN74H52			UNIT
	MIN	NOM	MAX	MIN	NOM	MAX	
V _{CC} Supply voltage	4.5	5	5.5	4.75	5	5.25	V
V _{IH} High-level input voltage	2			2			V
V _{IL} Low-level input voltage	0.8			0.8			V
I _{OH} High-level output current	-0.5			-0.5			mA
I _{OL} Low-level output current	20			20			mA
T _A Operating free-air temperature	-55			0			70 °C

electrical characteristics over recommended operating free-air temperature range (unless otherwise noted)

PARAMETER	TEST CONDITIONS†	SN54H52			SN74H52			UNIT
		MIN	TYP‡	MAX	MIN	TYP‡	MAX	
V _{IK}	V _{CC} = MIN, I _I = -8 mA	-1.5			-1.5			V
V _{OH}	V _{CC} = MIN, V _{IH} = 2 V, I _{OH} = -0.5 mA	2.4	3.4		2.4	3.4	V	
V _{OL}	V _{CC} = MIN, V _{IL} = 0.8 V, I _{OL} = 20 mA	0.2			0.2			V
I _I	V _{CC} = MAX, V _I = 5.5 V	1			1			mA
I _{IH}	V _{CC} = MAX, V _{IH} = 2.4 V	50			50			μA
I _{IL}	V _{CC} = MAX, V _{IL} = 0.4 V	-2			-2			mA
I _{OS} §	V _{CC} = MAX	-40		-100	-40		-100	mA
I _{CCH}	V _{CC} = MAX, See Note 2	20		31	20		31	mA
I _{CCL}	V _{CC} = MAX, V _I = 0 V	15.2		24	15.2		24	mA
I _X ▲	V _X = 1 V, I _{OH} = -0.5 mA	-2.7		-4.5	-2.9		-5.35	mA
V _{OH} ▲	V _X = 1 V, I _{OH} = -0.5 mA	2.4	3.4		2.4	3.4	V	
V _{OL} ▲	I _X = -0.3 mA, I _{OL} = 20 mA, T _A = MAX	0.2		0.4	0.2		0.4	V

† For conditions shown as MIN or MAX, use the appropriate value specified under recommended operating conditions.

‡ All typical values are at V_{CC} = 5 V, T_A = 25°C.

§ Not more than one output should be shorted at a time, and the duration of the short circuit should not exceed one second.

NOTE 2: All inputs of one AND gate at 4.5 V, all others at GND.

▲ Using expander inputs, V_{CC} = MIN, T_A = MIN (unless otherwise noted).

switching characteristics, V_{CC} = 5 V, T_A = 25°C (see note 3)

PARAMETER	FROM (INPUT)	TO (OUTPUT)	TEST CONDITIONS	MIN	TYP	MAX	UNIT	
t _{PLH}	Any	Y	R _L = 280 Ω, Expander pins open	C _L = 25 pF	10.6	15	ns	
t _{PHL}					9.2	15	ns	
t _{PLH}			R _L = 280 Ω, Ground to X	C _L = 25 pF,	C = 15 pF	14.8		ns
t _{PHL}						9.8		ns

NOTE 3: See General Information Section for load circuits and voltage waveforms.

3

TTL DEVICES

TYPES SN5453, SN54H53, SN7453, SN74H53 EXPANDABLE 4-WIDE AND-OR-INVERT GATES

REVISED DECEMBER 1983

- Package Options Include Plastic and Ceramic DIPs
- Dependable Texas Instruments Quality and Reliability

description

These devices contain expandable 4-wide AND-OR-INVERT gates. The '53 perform the Boolean function $Y = \overline{AB + CD + EF + GH + X}$ and the 'H53 perform $Y = \overline{AB + CD + EFG + HI + X}$ with $X =$ output of SN5460/SN7460, SN54H60/SN74H60 or SN54H62/SN74H62 respectively.

The SN5453 and SN54H53 are characterized for operation over the full military temperature range of -55°C to 125°C . The SN7453 and SN74H53 are characterized for operation from 0°C to 70°C .

logic diagrams

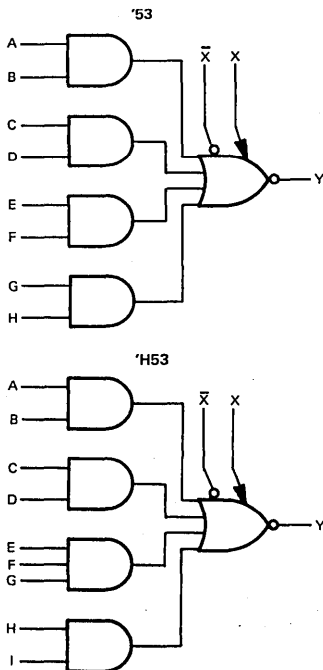

SN5453 ... J PACKAGE
SN7453 ... J OR N PACKAGE
(TOP VIEW)

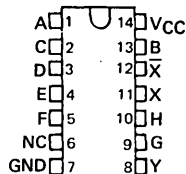

SN5453 ... W PACKAGE
(TOP VIEW)

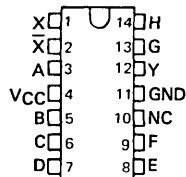

SN54H53 ... J PACKAGE
SN74H53 ... J OR N PACKAGE
(TOP VIEW)

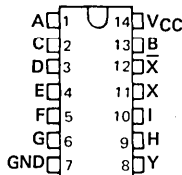

SN54H53 ... W PACKAGE
(TOP VIEW)

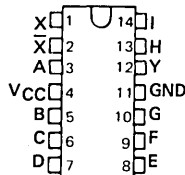

NC - No internal connection

TYPES SN5453, SN54H53,
SN7453, SN74H53
EXPANDABLE 4-WIDE AND-OR-INVERT GATES

schematics

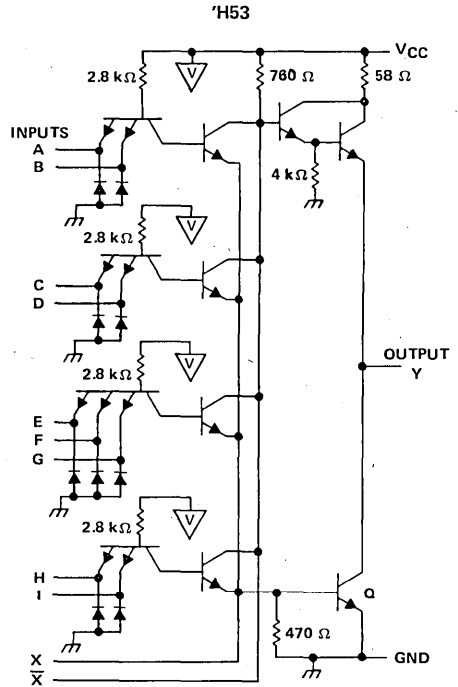
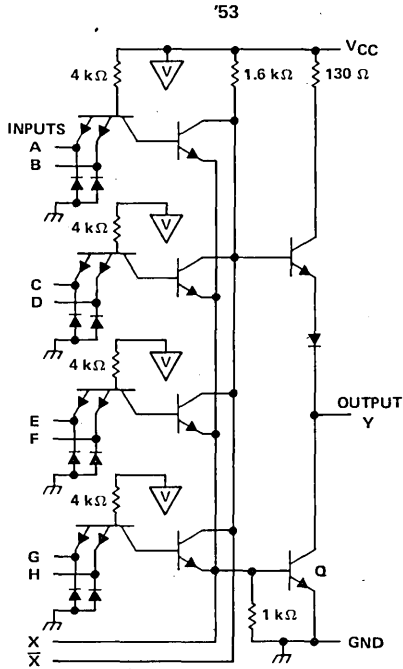

Resistor values shown are nominal.
If expander is not used, leave X and \bar{X} open.

absolute maximum ratings over operating free-air temperature range (unless otherwise noted)

Supply voltage, V_{CC} (see Note 1)	7 V
Input voltage	5.5 V
Operating free-air temperature range: SN54'	-55°C to 125°C
SN74'	0°C to 70°C
Storage temperature range	-65°C to 150°C

NOTE 1: Voltage values are with respect to network ground terminal.

3
TTL DEVICES

TYPES SN5453, SN7453 EXPANDABLE 4-WIDE AND-OR-INVERT GATES

recommended operating conditions

	SN5453			SN7453			UNIT
	MIN	NOM	MAX	MIN	NOM	MAX	
V _{CC} Supply voltage	4.5	5	5.5	4.75	5	5.25	V
V _{IH} High-level input voltage	2			2			V
V _{IL} Low-level input voltage	0.8			0.8			V
I _{OH} High-level output current	-0.4			-0.4			mA
I _{OL} Low-level output current	16			16			mA
T _A Operating free-air temperature	-55			125			°C

electrical characteristics over recommended operating free-air temperature range (unless otherwise noted)

PARAMETER	TEST CONDITIONS†	SN5453		SN7453		UNIT
		MIN	TYP‡	MAX	MIN	
V _{IK}	V _{CC} = MIN, I _I = -12 mA	-1.5		-1.5		V
V _{OH}	V _{CC} = MIN, V _{IL} = 0.8 V, I _{OH} = -0.4 mA	2.4	3.4	2.4	3.4	V
V _{OL}	V _{CC} = MIN, V _{IH} = 2 V, I _{OL} = 16 mA	0.2	0.4	0.2	0.4	V
I _I	V _{CC} = MAX, V _I = 5.5 V	1		1		mA
I _{IH}	V _{CC} = MAX, V _{IH} = 2.4 V	40		40		μA
I _{IL}	V _{CC} = MAX, V _{IL} = 0.4 V	-1.6		-1.6		mA
I _{OS} §	V _{CC} = MAX	-20	-55	-18	-55	mA
I _{CCH}	V _{CC} = MAX, V _I = 0 V	4		4		mA
I _{CCL}	V _{CC} = MAX, See Note 2	5.1	9.5	5.1	9.5	mA
I _X ▲	V _X = 0.4 V, I _{OL} = 16 mA	-2.9		-3.1		mA
V _{BE(Q)} ▲	I _X +I _X = 0.41 mA, R _X X = 0, I _{OL} = 16 mA	1.1				V
V _{OH} ▲	I _X = 0.15 mA, I _X = -0.15 mA, I _{OH} = -0.4 mA	2.4	3.4			V
	I _X = 0.27 mA, I _X = -0.27 mA, I _{OH} = -0.4 mA			2.4	3.4	V
V _{OL} ▲	I _X +I _X = 0.3 mA, R _X X = 138 Ω, I _{OL} = 16 mA	0.2	0.4			V
	I _X +I _X = 0.43 mA, R _X X = 130 Ω, I _{OL} = 16 mA			0.2	0.4	V

† For conditions shown as MIN or MAX, use the appropriate value specified under recommended operating conditions.

‡ All typical values are at V_{CC} = 5 V, T_A = 25°C.

§ Not more than one output should be shorted at a time.

▲ Using expander inputs, V_{CC} = MIN, T_A = MIN, except typical values

NOTE 2: All inputs of one AND gate at 4.5 V, all others at GND.

switching characteristics, V_{CC} = 5 V, T_A = 25°C (see note 3)

PARAMETER	FROM (INPUT)	TO (OUTPUT)	TEST CONDITIONS	MIN	TYP	MAX	UNIT
t _{PLH}	Any	Y	R _L = 400 Ω, C _L = 15 pF ¶	13		22	ns
t _{PHL}				8		15	ns

¶ Expander pins open.

NOTE 3: See General Information Section for load circuits and voltage waveforms.

**TYPES SN54H53, SN74H53,
EXPANDABLE 4-WIDE AND-OR-INVERT GATES**

recommended operating conditions

	SN54H53			SN74H53			UNIT
	MIN	NOM	MAX	MIN	NOM	MAX	
V _{CC} Supply voltage	4.5	5	5.5	4.75	5	5.25	V
V _{IH} High-level input voltage	2			2			V
V _{IL} Low-level input voltage				0.8			V
I _{OH} High-level output current				-0.5			mA
I _{OL} Low-level output current				20			mA
T _A Operating free-air temperature	-55			125			°C

electrical characteristics over recommended operating free-air temperature range (unless otherwise noted)

PARAMETER	TEST CONDITIONS†	SN54H53		SN74H53		UNIT
		MIN	TYP‡	MAX	MIN	
V _{IK}	V _{CC} = MIN, I _I = -8 mA			-1.5		V
V _{OH}	V _{CC} = MIN, V _{IL} = 0.8 V, I _{OH} = -0.5 mA	2.4	3.4	2.4	3.4	V
V _{OL}	V _{CC} = MIN, V _{IH} = 2 V, I _{OL} = 20 mA	0.2		0.4		V
I _I	V _{CC} = MAX, V _I = 5.5 V			1		mA
I _{IH}	V _{CC} = MAX, V _{IH} = 2.4 V			50		µA
I _{IL}	V _{CC} = MAX, V _{IL} = 0.4 V			-2		mA
I _{OS} §	V _{CC} = MAX	-40		-100		mA
I _{CCH}	V _{CC} = MAX, V _I = 0 V	7.1		11		mA
I _{CCL}	V _{CC} = MAX, See Note 2	9.4		14		mA
I _X ▲	V _X = 1.4 V, I _X = 0, I _{OL} = 0			-5.85		mA
V _{BE(Q)} ▲	I _X + I _X = 0.7 mA, R _X X = 0, I _{OL} = 20 mA			1.1		V
	I _X + I _X = 1.1 mA, R _X X = 0, I _{OL} = 20 mA					
V _{OH} ▲	I _X = 0.32 mA, I _X = -0.32 mA, I _{OH} = -0.5 mA	2.4	3.4			V
	I _X = 0.57 mA, I _X = -0.57 mA, I _{OH} = -0.5 mA			2.4		
V _{OL} ▲	I _X + I _X = 0.47 mA, R _X X = 68 Ω, I _{OL} = 20 mA	0.2		0.4		V
	I _X + I _X = 0.6 mA, R _X X = 63 Ω, I _{OL} = 20 mA			0.2		

† For conditions shown as MIN or MAX, use the appropriate value specified under recommended operating conditions.

‡ All typical values are at V_{CC} = 5 V, T_A = 25°C.

§ Not more than one output should be shorted at a time.

▲ Using expander inputs, V_{CC} = MIN, T_A = MIN, except typical values.

NOTE 2: All inputs of one AND gate at 4.5 V, all others at GND.

switching characteristics, V_{CC} = 5 V, T_A = 25°C (see note 3)

PARAMETER	FROM (INPUT)	TO (OUTPUT)	TEST CONDITIONS	MIN	TYP	MAX	UNIT
t _{PLH}	Any	Y	R _L = 280 Ω, C _L = 25 pF ¶	7		11	ns
t _{PHL}				6.2		11	ns
t _{PLH}			R _L = 280 Ω, C _L = 25 pF ¶ C = 15 pF #	11.4			ns
t _{PHL}				7.4			ns

¶ Expander pins open.

GND to X.

NOTE 3: See General Information Section for load circuits and voltage waveforms.

TTL DEVICES

TYPES SN5454, SN54H54, SN54L54, SN54LS54, SN7454, SN74H54, SN74LS54 4-WIDE AND-OR-INVERT GATES

REVISED DECEMBER 1983

- Package Options Include Both Plastic and Ceramic Chip Carriers in Addition to Plastic and Ceramic DIPs
- Dependable Texas Instruments Quality and Reliability

description

These devices contain 4-wide AND-OR-INVERT gates. They perform the following Boolean functions:

$${}^{\prime}54 \quad Y = \overline{AB + CD + EF + GH}$$

$${}^{\prime}H54 \quad Y = \overline{AB + CD + EFG + HI}$$

$${}^{\prime}L54, LS54 \quad Y = \overline{AB + CDE + FGH + IJ}$$

The SN5454, SN54H54, SN54L54, and the SN54LS54 are characterized for operation over the full military temperature range of -55°C to 125°C . The SN7454, SN74H54, and the SN74LS54 are characterized for operation from 0°C to 70°C .

logic diagrams

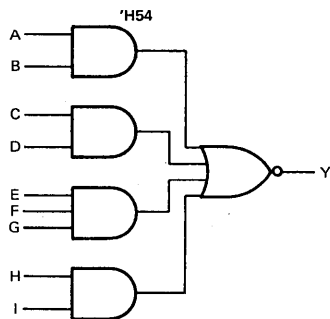
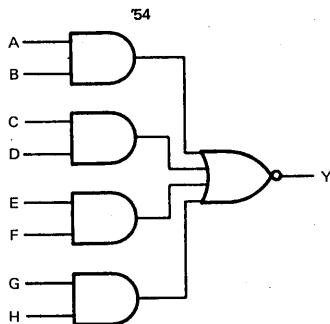

SN5454 . . . J PACKAGE
SN7454 . . . J OR N PACKAGE

(TOP VIEW)

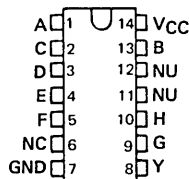

SN5454 . . . W PACKAGE

(TOP VIEW)

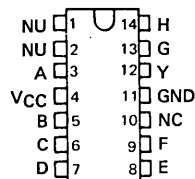

SN54H54 . . . J PACKAGE
SN74H54 . . . J OR N PACKAGE

(TOP VIEW)

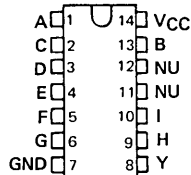

SN54H54 . . . W PACKAGE

(TOP VIEW)

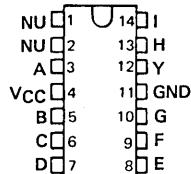

NC - No internal connection

NU - Make no external connection

PRODUCTION DATA

This document contains information current as of publication date. Products conform to specifications per the terms of Texas Instruments standard warranty. Production processing does not necessarily include testing of all parameters.

TEXAS
INSTRUMENTS

POST OFFICE BOX 225012 • DALLAS, TEXAS 75265

3

TTL DEVICES

**TYPES SN5454, SN54H54, SN54L54, SN54LS54,
SN7454, SN74H54, SN74LS54
4-WIDE AND-OR-INVERT GATES**

logic diagrams (continued)

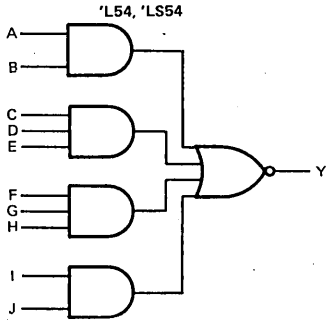

schematics

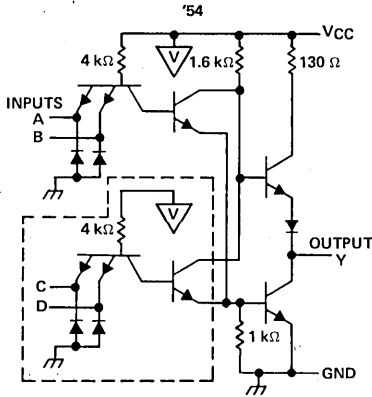

Resistor values shown are nominal.
The portion of the circuits within the dashed lines is repeated for each additional AND section.

SN54L54 ... J PACKAGE
SN54LS54 ... J OR W PACKAGE
SN74LS54 ... D, J OR N PACKAGE
(TOP VIEW)

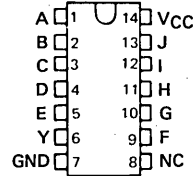

SN54LS54 ... FK PACKAGE
SN74LS54 ... FN PACKAGE
(TOP VIEW)

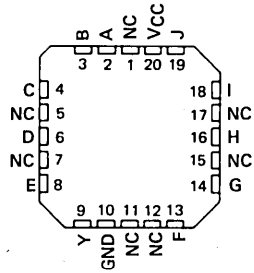

NC - No internal connection
NU - Make no external connection

TYPES SN5454, SN54H54, SN54L54, SN54LS54,
 SN7454, SN74H54, SN74LS54
 4-WIDE AND-OR-INVERT GATES

schematics (continued)

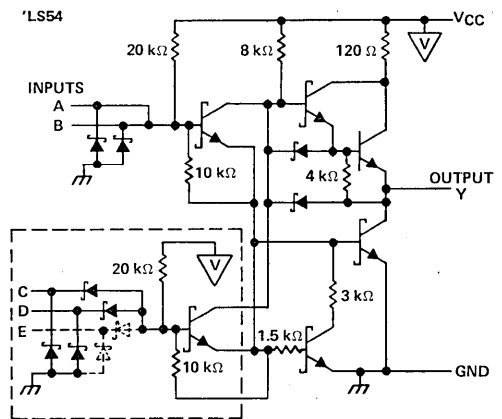
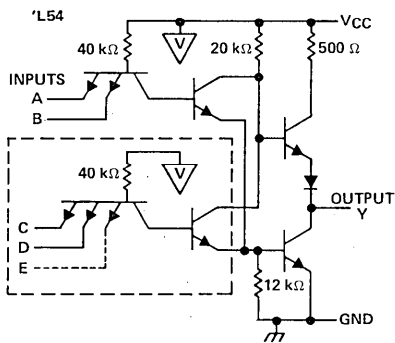
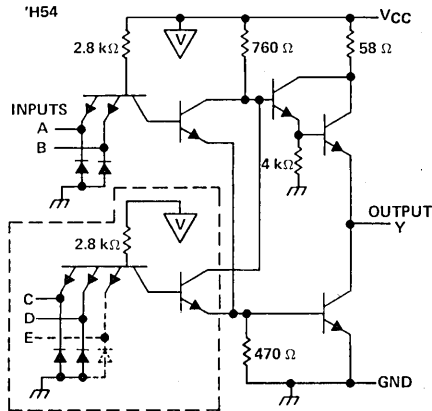

Resistor values shown are nominal.

In 'L54 and 'LS54 circuits, 3-input gate represented by additional dashed line.

The portion of the circuits within the dashed lines is repeated for each additional AND section.

absolute maximum ratings over operating free-air temperature range (unless otherwise noted)

Supply voltage, V_{CC} (see Note 1): '54, 'H54, 'L54	7 V
'L54	8 V
Input voltage: '54, 'H54, 'L54	5.5 V
'LS54	7 V
Operating free-air temperature range: SN54'	-55°C to 125°C
SN74'	0°C to 70°C
Storage temperature range	-65°C to 150°C

NOTE 1: Voltage values are with respect to network ground terminal.

TYPES SN5454, SN7454

4-WIDE AND-OR-INVERT GATES

recommended operating conditions

	SN5454			SN7454			UNIT
	MIN	NOM	MAX	MIN	NOM	MAX	
V _{CC} Supply voltage	4.5	5	5.5	4.75	5	5.25	V
V _{IH} High-level input voltage	2			2			V
V _{IL} Low-level input voltage			0.8			0.8	V
I _{OH} High-level output current			-0.4			-0.4	mA
I _{OL} Low-level output current			16			16	mA
T _A Operating free-air temperature	-55		125	0		70	°C

electrical characteristics over recommended operating free-air temperature range (unless otherwise noted)

PARAMETER	TEST CONDITIONS†	SN5454			SN7454			UNIT
		MIN	TYP‡	MAX	MIN	TYP‡	MAX	
V _{IK}	V _{CC} = MIN, I _I = -12 mA			-1.5			-1.5	V
V _{OH}	V _{CC} = MIN, V _{IL} = 0.8 V, I _{OH} = -0.4 mA	2.4	3.4		2.4	3.4		V
V _{OL}	V _{CC} = MIN, V _{IH} = 2 V, I _{OL} = 16 mA		0.2	0.4		0.2	0.4	V
I _I	V _{CC} = MAX, V _I = 5.5 V			1			1	mA
I _{IH}	V _{CC} = MAX, V _I = 2.4 V			40			40	μA
I _{IL}	V _{CC} = MAX, V _I = 0.4 V			-1.6			-1.6	mA
I _{OS} §	V _{CC} = MAX	-20		-55	-18		-55	mA
I _{CCH}	V _{CC} = MAX, V _I = 0 V		4	8		4	8	mA
I _{CCL}	V _{CC} = MAX, See Note 2		5.1	9.5		5.1	9.5	mA

† For conditions shown as MIN or MAX, use the appropriate value specified under recommended operating conditions.

‡ All typical values are at V_{CC} = 5 V, T_A = 25°C.

§ Not more than one output should be shorted at a time.

NOTE 2: All inputs of one AND gate at 4.5 V, all others at GND.

switching characteristics, V_{CC} = 5 V, T_A = 25°C (see note 3)

PARAMETER	FROM (INPUT)	TO (OUTPUT)	TEST CONDITIONS	MIN	TYP	MAX	UNIT
t _{PLH}	Any	Y	R _L = 400 Ω, C _L = 15 pF		13	22	ns
t _{PHL}				8	15	ns	

NOTE 3: See General Information Section for load circuits and voltage waveforms.

recommended operating conditions

	SN54H54			SN74H54			UNIT
	MIN	NOM	MAX	MIN	NOM	MAX	
V _{CC} Supply voltage	4.5	5	5.5	4.75	5	5.25	V
V _{IH} High-level input voltage	2			2			V
V _{IL} Low-level input voltage	0.8			0.8			V
I _{OH} High-level output current	-0.5			-0.5			mA
I _{OL} Low-level output current	20			20			mA
T _A Operating free-air temperature	-55 125			0 70			°C

electrical characteristics over recommended operating free-air temperature range (unless otherwise noted)

PARAMETER	TEST CONDITIONS†	MIN	TYP‡	MAX	UNIT
V _{IK}	V _{CC} = MIN, I _I = -8 mA			-1.5	V
V _{OH}	V _{CC} = MIN, V _{IL} = 0.8 V, I _{OH} = -0.5 mA	2.4	3.4		V
V _{OL}	V _{CC} = MIN, V _{IH} = 2 V, I _{OL} = 20 mA		0.2	0.4	V
I _I	V _{CC} = MAX, V _I = 5.5 V			1	mA
I _{IH}	V _{CC} = MAX, V _I = 2.4 V			50	μA
I _{IL}	V _{CC} = MAX, V _I = 0.4 V			-2	mA
I _{OS§}	V _{CC} = MAX	-40		-100	mA
I _{CCH}	V _{CC} = MAX, V _I = 0 V		7.1	11	mA
I _{CCL}	V _{CC} = MAX, See Note 2		9.4	14	mA

† For conditions shown as MIN or MAX, use the appropriate value specified under recommended operating conditions.

‡ All typical values are at V_{CC} = 5 V, T_A = 25°C.

§ Not more than one output should be shorted at a time, and the duration of the short circuit should not exceed one second.

NOTE 2: An inputs of one AND gate at 4.5 V, all others at GND.

switching characteristics, V_{CC} = 5 V, T_A = 25°C (see note 3)

PARAMETER	FROM (INPUT)	TO (OUTPUT)	TEST CONDITIONS		MIN	TYP	MAX	UNIT
t _{PLH}	Any	Y	R _L = 280 Ω,	C _L = 25 pF		7	11	ns
t _{PHL}						6.2	11	ns

NOTE 3: See General Information Section for load circuits and voltage waveforms.

3
TTL DEVICES

TYPE SN54L54

4-WIDE AND-OR-INVERT GATES

recommended operating conditions

	SN54L54			UNIT
	MIN	NOM	MAX	
V _{CC} Supply voltage	4.5	5	5.5	V
V _{IH} High-level input voltage	2			V
V _{IL} Low-level input voltage	0.7			V
I _{OH} High-level output current	-0.1			mA
I _{OL} Low-level output current	2			mA
T _A Operating free-air temperature	-55	125		°C

electrical characteristics over recommended operating free-air temperature range (unless otherwise noted)

PARAMETER	TEST CONDITIONS†	SN54L54			UNIT	
		MIN	TYP‡	MAX		
V _{OH}	V _{CC} = MIN, V _{IL} = 0.7 V, I _{OH} = -0.1 mA	2.4	3.3		V	
V _{OL}	V _{CC} = MIN, V _{IH} = 2 V, I _{OL} = 2 mA	0.15			0.3	V
I _I	V _{CC} = MAX, V _I = 5.5 V	0.1			mA	
I _{IH}	V _{CC} = MAX, V _I = 2.4 V	10			μA	
I _{IL}	V _{CC} = MAX, V _I = 0.3 V	-0.18			mA	
I _{OSS} §	V _{CC} = MAX	-3	-15		mA	
I _{CC1}	V _{CC} = MAX, V _I = 0 V	0.39			0.8	mA
I _{CCL}	V _{CC} = MAX, See Note 2	0.60			0.9	mA

† For conditions shown as MIN or MAX, use the appropriate value specified under recommended operating conditions.

‡ All typical values are at V_{CC} = 5 V, T_A = 25°C.

§ Not more than one output should be shorted at a time.

NOTE 2: All inputs of one AND gate at 4.5 V, all others at GND.

switching characteristics, V_{CC} = 5 V, T_A = 25°C (see note 3)

PARAMETER	FROM (INPUT)	TO (OUTPUT)	TEST CONDITIONS	MIN	TYP	MAX	UNIT
t _{PLH}	Any	Y	R _L = 4 kΩ, C _L = 50 pF	50	90		ns
t _{PHL}				35	60		ns

NOTE 3: See General Information Section for load circuits and voltage waveforms.

TYPES SN54LS54, SN74LS54 4-WIDE AND-OR-INVERT GATES

recommended operating conditions

	SN54LS54			SN74LS54			UNIT
	MIN	NOM	MAX	MIN	NOM	MAX	
V _{CC} Supply voltage	4.5	5	5.5	4.75	5	5.25	V
V _{IH} High-level input voltage	2			2			V
V _{IL} Low-level input voltage			0.7			0.8	V
I _{OH} High-level output current			-0.4			-0.4	mA
I _{OL} Low-level output current			4			8	mA
T _A Operating free-air temperature	-55		125	0		70	°C

electrical characteristics over recommended operating free-air temperature range (unless otherwise noted)

PARAMETER	TEST CONDITIONS†	SN54LS54			SN74LS54			UNIT
		MIN	TYP‡	MAX	MIN	TYP‡	MAX	
V _{IK}	V _{CC} = MIN, I _I = -18 mA			-1.5			-1.5	V
V _{OH}	V _{CC} = MIN, V _{IL} = MAX, I _{OH} = -0.4 mA	2.5	3.4		2.7	3.4		V
V _{OL}	V _{CC} = MIN, V _{IH} = 2 V, I _{OL} = 4 mA		0.25	0.4		0.25	0.4	V
	V _{CC} = MIN, V _{IH} = 2 V, I _{OL} = 8 mA					0.35	0.5	
I _I	V _{CC} = MAX, V _I = 7 V			0.1			0.1	mA
I _{IH}	V _{CC} = MAX, V _I = 2.7 V			20			20	μA
I _{IL}	V _{CC} = MAX, V _I = 0.4 V			-0.4			-0.4	mA
I _{OS} §	V _{CC} = MAX	-20		-100	-20		-100	mA
I _{CCH}	V _{CC} = MAX, V _I = 0 V		0.8	1.6		0.8	1.6	mA
I _{CCL}	V _{CC} = MAX, See Note 2		1	2		1	2	mA

† For conditions shown as MIN or MAX, use the appropriate value specified under recommended operating conditions.

‡ All typical values are at V_{CC} = 5 V, T_A = 25°C.

§ Not more than one output should be shorted at a time, and the duration of the short-circuit should not exceed one second.

NOTE 2: All inputs of one AND gate at 4.5 V, all others at GND.

switching characteristics, V_{CC} = 5 V, T_A = 25°C (see note 3)

PARAMETER	FROM (INPUT)	TO (OUTPUT)	TEST CONDITIONS	MIN	TYP	MAX	UNIT
t _{PLH}	Any	Y	R _L = 2 kΩ, C _L = 15 pF		12	20	ns
t _{PHL}					12.5	20	ns

NOTE 3: See General Information Section for load circuits and voltage waveforms.



TTL DEVICES

TYPES SN54H55, SN54L55, SN54LS55, SN74H55, SN74LS55 2-WIDE 4-INPUT AND-OR-INVERT GATES

REVISED DECEMBER 1983

- Package Options Include Both Plastic and Ceramic Chip Carriers in Addition to Plastic and Ceramic DIPs
- Dependable Texas Instruments Quality and Reliability

description

These devices contain 2-wide 4-input AND-OR-INVERT gates. The 'L55 and 'LS55 perform the Boolean function $Y = ABCD + EFGH$. The 'H55 is expandable and performs the Boolean function $Y = ABCD + EFGH + X$ with $X =$ output of SN54H60/SN74H60 or SN54H62/SN74H62.

The SN54H55, SN54L55, and the SN54LS55 are characterized for operation over the full military temperature range of -55° to 125°C . The SN74H55 and SN74LS55 are characterized for operation from 0°C to 70°C .

logic diagrams

'H55, EXPANDABLE

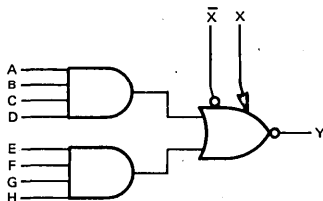

'L55, 'LS55

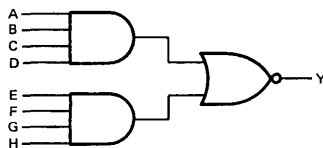

SN54H55 ... J PACKAGE
SN74H55 ... J OR N PACKAGE
(TOP VIEW)

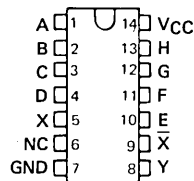

SN54H55 ... W PACKAGE
(TOP VIEW)

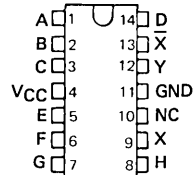

SN54L55 ... J PACKAGE
SN54LS55 ... J OR W PACKAGE
SN74LS55 ... D, J OR N PACKAGE
(TOP VIEW)

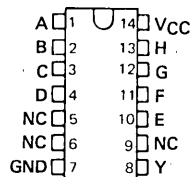

SN54LS55 ... FK PACKAGE
SN74LS55 ... FN PACKAGE
(TOP VIEW)

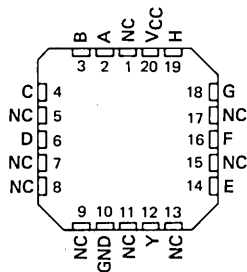

NC - No internal connection

PRODUCTION DATA
This document contains information current as of publication date. Products conform to specifications per the terms of Texas Instruments standard warranty. Production processing does not necessarily include testing of all parameters.

**TEXAS
INSTRUMENTS**
POST OFFICE BOX 225012 • DALLAS, TEXAS 75265

3-237

TTL DEVICES

**TYPES SN54H55, SN54L55, SN54LS55,
SN74H55, SN74LS55
2-WIDE 4-INPUT AND-OR-INVERT GATES**

schematics

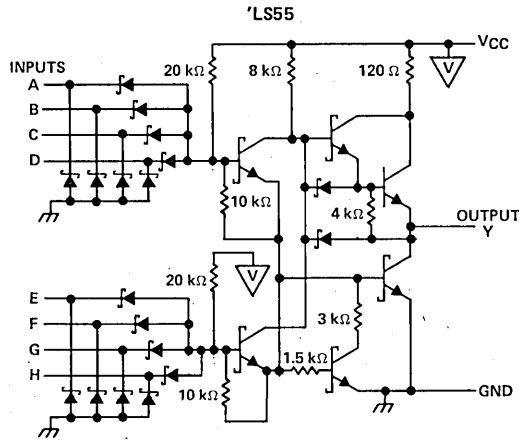
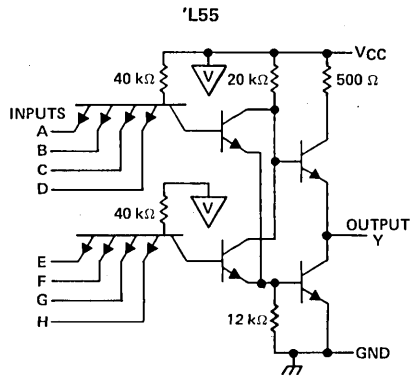
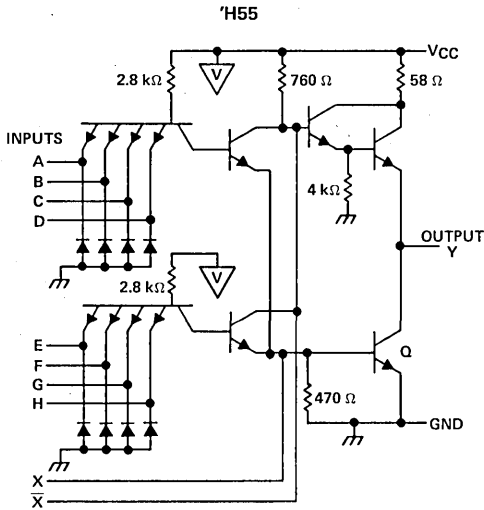

Resistor values shown are nominal.

absolute maximum ratings over operating free-air temperature range (unless otherwise noted)

Supply voltage, V_{CC} (see Note 1)	7 V
Input voltage: 'H55, 'L55	5.5 V
'LS55	7 V
Operating free-air temperature range: SN54'	-55°C to 125°C
SN74'	0°C to 70°C
Storage temperature range	-65°C to 150°C

NOTE 1: Voltage values are with respect to network ground terminal.

TYPES SN54H55, SN74H55 2-WIDE 4-INPUT AND-OR-INVERT GATES

recommended operating conditions

	SN54H55			SN74H55			UNIT
	MIN	NOM	MAX	MIN	NOM	MAX	
V _{CC} Supply voltage	4.5	5	5.5	4.75	5	5.25	V
V _{IH} High-level input voltage	2			2			V
V _{IL} Low-level input voltage			0.8			0.8	V
I _{OH} High-level output current			-0.5			-0.5	mA
I _{OL} Low-level output current			20			20	mA
T _A Operating free-air temperature	-55		125	0		70	°C

electrical characteristics over recommended operating free-air temperature range (unless otherwise noted)

PARAMETER	TEST CONDITIONS†	SN54H55			SN74H55			UNIT
		MIN	TYP‡	MAX	MIN	TYP‡	MAX	
V _{IK}	V _{CC} = MIN, I _I = -8 mA			-1.5			-1.5	V
V _{OH}	V _{CC} = MIN, V _{IL} = 0.8 V, I _{OH} = -0.5 mA	2.4	3.4		2.4	3.4		V
V _{OL}	V _{CC} = MIN, V _{IH} = 2 V, I _{OL} = 20 mA		0.2	0.4		0.2	0.4	V
I _I	V _{CC} = MAX, V _I = 5.5 V			1			1	mA
I _{IH}	V _{CC} = MAX, V _{IH} = 2.4 V			50			50	μA
I _{IL}	V _{CC} = MAX, V _{IL} = 0.4 V			-2			-2	mA
I _{OS} §	V _{CC} = MAX	-40		-100	-40		-100	mA
I _{CCH}	V _{CC} = MAX, V _I = 0 V		4.5	6.4		4.5	6.4	mA
I _{CCL}	V _{CC} = MAX, See Note 2		7.5	12		7.5	12	mA
I _X ▲	V _{XX} = 1.4 V, I _X = 0, I _{OL} = 0			-5.85			-6.3	mA
V _{BE(Q)} ▲	I _X + I _X = 0.7 mA, R _{XX} = 0, I _{OL} = 20 mA			1.1				V
	I _X + I _X = 1.1 mA, R _{XX} = 0, I _{OL} = 20 mA						1	V
V _{OH} ▲	I _X = 0.32 mA, I _X = -0.32 mA, I _{OH} = -0.5 mA	2.4	3.4					V
	I _X = 0.57 mA, I _X = -0.57 mA, I _{OH} = -0.5 mA				2.4	3.4		V
V _{OL} ▲	I _X + I _X = 0.47 mA, R _{XX} = 68 Ω, I _{OL} = 20 mA		0.2	0.4				V
	I _X + I _X = 0.6 mA, R _{XX} = 63 Ω, I _{OL} = 20 mA						0.2	0.4

† For conditions shown as MIN or MAX, use the appropriate value specified under recommended operating conditions.

‡ All typical values are at V_{CC} = 5 V, T_A = 25°C.

§ Not more than one output should be shorted at a time.

▲ Using expander inputs, V_{CC} = MIN, T_A = MIN, except typical values.

NOTE 2: All inputs of one AND gate at 4.5 V, all others at GND.

switching characteristics, V_{CC} = 5 V, T_A = 25°C (see note 3)

PARAMETER	FROM (INPUT)	TO (OUTPUT)	TEST CONDITIONS	MIN	TYP	MAX	UNIT	
t _{PLH}	Any	Y	R _L = 280 Ω, C _L = 25 pF ¶		7	11	ns	
t _{PHL}					6.5	11	ns	
t _{PLH}			R _L = 280 Ω, C _L = 25 pF, C = 15 pF #			11.4		ns
t _{PHL}						7.7		ns

NOTE 3: See General Information Section for load circuits and voltage waveforms.

¶ Expander pins open.

GND to X.



TTL DEVICES

TYPE SN54L55

2-WIDE 4-INPUT AND-OR-INVERT GATES

recommended operating conditions

	SN54L55			UNIT
	MIN	NOM	MAX	
V _{CC} Supply voltage	4.5	5	5.5	V
V _{IH} High-level input voltage	2			V
V _{IL} Low-level input voltage	0.7			V
I _{OH} High-level output current	-0.1			mA
I _{OL} Low-level output current	2			mA
T _A Operating free-air temperature	-55	125		°C

electrical characteristics over recommended operating free-air temperature range (unless otherwise noted)

PARAMETER	TEST CONDITIONS†			SN54L55			UNIT
				MIN	TYP‡	MAX	
V _{OH}	V _{CC} = MIN,	V _{IL} = 0.7 V,	I _{OH} = -0.1 mA	2.4	3.3		V
V _{OL}	V _{CC} = MIN,	V _{IH} = 2 V,	I _{OL} = 2 mA	0.15	0.33		V
I _I	V _{CC} = MAX,	V _I = 5.5 V			0.1		mA
I _{IH}	V _{CC} = MAX,	V _I = 2.4 V			10		μA
I _{IL}	V _{CC} = MAX,	V _I = 0.3 V			-0.18		mA
I _{OS} §	V _{CC} = MAX			-3	-15		mA
I _{CCH}	V _{CC} = MAX,	V _I = 0 V		0.22	0.4		mA
I _{CCL}	V _{CC} = MAX,	See Note 2		0.38	0.65		mA

† For conditions shown as MIN or MAX, use the appropriate value specified under recommended operating conditions.

‡ All typical values are at V_{CC} = 5 V, T_A = 25°C.

§ Not more than one output should be shorted at a time.

NOTE 2: All inputs of one AND gate at 4.5 V, all others at GND.

switching characteristics, V_{CC} = 5 V, T_A = 25°C (see note 3)

PARAMETER	FROM (INPUT)	TO (OUTPUT)	TEST CONDITIONS	MIN	TYP	MAX	UNIT
t _{PLH}	Any	Y	R _L = 4 kΩ, C _L = 50 pF	50	90		ns
t _{PHL}				35	60		ns

NOTE 3: See General Information Section for load circuits and voltage waveforms.

TYPES SN54LS55, SN74LS55 2-WIDE 4-INPUT AND-OR-INVERT GATES

recommended operating conditions

	SN54LS55			SN74LS55			UNIT
	MIN	NOM	MAX	MIN	NOM	MAX	
V _{CC} Supply voltage	4.5	5	5.5	4.75	5	5.25	V
V _{IH} High-level input voltage	2			2			V
V _{IL} Low-level input voltage			0.7			0.8	V
I _{OH} High-level output current			-0.4			-0.4	mA
I _{OL} Low-level output current			4			8	mA
T _A Operating free-air temperature	-55		125	0		70	°C

electrical characteristics over recommended operating free-air temperature range (unless otherwise noted)

PARAMETER	TEST CONDITIONS†	SN54LS55			SN74LS55			UNIT	
		MIN	TYP‡	MAX	MIN	TYP‡	MAX		
V _{IK}	V _{CC} = MIN, I _I = -18 mA			-1.5			-1.5	V	
V _{OH}	V _{CC} = MIN, V _{IL} = MAX, I _{OH} = -0.4 mA	2.5	3.4		2.7	3.4		V	
V _{OL}	V _{CC} = MIN, V _{IH} = 2 V, I _{OL} = 4 mA		0.25	0.4		0.25	0.4	V	
	V _{CC} = MIN, V _{IH} = 2 V, I _{OL} = 8 mA					0.35	0.5		
I _I	V _{CC} = MAX, V _I = 7 V			0.1			0.1	mA	
I _{IH}	V _{CC} = MAX, V _I = 2.7 V			20			20	μA	
I _{IL}	V _{CC} = MAX, V _I = 0.4 V			-0.4			-0.4	mA	
I _{OS} §	V _{CC} = MAX	-20		-100	-20		-100	mA	
I _{CCH}	V _{CC} = MAX, V _I = 0 V			0.4			0.4	0.8	mA
I _{CCL}	V _{CC} = MAX, See Note 2			0.7			0.7	1.3	mA

† For conditions shown as MIN or MAX, use the appropriate value specified under recommended operating conditions.

‡ All typical values are at V_{CC} = 5 V, T_A = 25°C.

§ Not more than one output should be shorted at a time, and the duration of the short-circuit should not exceed one second.

NOTE 2: All outputs of one AND gate at 4.5 V, all others at GND.

switching characteristics, V_{CC} = 5 V, T_A = 25°C (see note 3)

PARAMETER	FROM (INPUT)	TO (OUTPUT)	TEST CONDITIONS		MIN	TYP	MAX	UNIT
t _{PLH}	Any	Y	R _L = 2 kΩ,	C _L = 15 pF		12	20	ns
t _{PHL}						12.5	20	ns

NOTE 3: See General Information Section for load circuits and voltage waveforms.

3
TTL DEVICES

TYPES SN54LS56, SN54LS57, SN74LS56, SN74LS57 FREQUENCY DIVIDERS

REVISED DECEMBER 1983

- 'LS56 Performs 50 to 1 Frequency Division (5 to 1, 5 to 1, and 10 to 1)
- 'LS57 Performs 60 to 1 Frequency Division (6 to 1, 5 to 1, and 10 to 1)
- Available in P or JG package (two P or JG Packages Fit in a Single 16-pin Socket)
- Maximum Clock Frequency 25 MHz Typical

SN54LS56, SN54LS57 . . . JG PACKAGE
SN74LS56, SN74LS57 . . . JG OR P PACKAGE

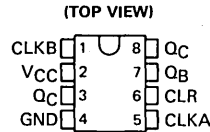

FOR CHIP CARRIER INFORMATION, CONTACT THE FACTORY.

description

These frequency dividers are particularly useful in generating one second or one hour timing pulses from 50 Hz (European standard frequency) or 60 Hz (United States standard frequency). 50 to 1 frequency division is accomplished in the 'LS56 by connecting output Q_A to input CLKB. 60 to 1 frequency division in the 'LS57 is accomplished in the same way. More universal capabilities are evidenced by the 25 MHz typical f_{max} and the almost limitless frequency division possibilities when used in cascade. Two 'LS56 packages may be interconnected to give frequency division of 2500 to 1, 625 to 1, 100 to 1, etc. Two 'LS57 packages can be connected to generate frequency divisions of 3600 to 1, 1800 to 1, 900 to 1 etc.

The 'LS56 and 'LS57 frequency dividers consist of three separate counters, A, B, and C on a single monolithic substrate. The A counter divides by 5 to 1 in the 'LS56 and by 6 to 1 in the 'LS57. The B counter divides by 5 to 1 in both devices and is internally tied to the C counter which divides by 2 to 1. The resulting C counter output is 10 to 1. Both the 'LS56 and 'LS57 feature a clear pin which is common to all three counters, A, B, and C. When the clear pin is low, the counters are enabled. When the clear is high, the counters are disabled and their outputs are set to a low-level.

All three counters, A, B, and C trigger on the high-to-low transition of the clock input. All output waveforms are symmetrical except for the 5 to 1 outputs (A and B of the 'LS56 and B of the 'LS57). See the output waveform drawings below.

3

TTL DEVICES

input and output waveforms

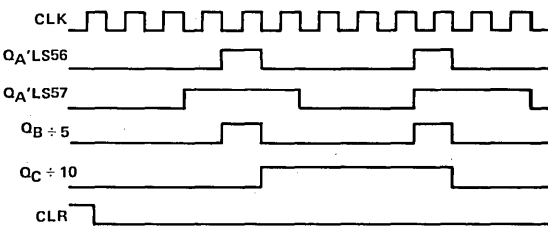

logic diagram

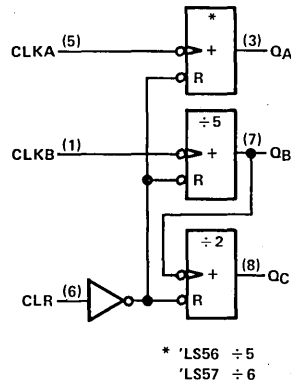

PRODUCTION DATA

This document contains information current as of publication date. Products conform to these specifications per the terms of Texas Instruments standard warranty. Production processing does not necessarily include testing of all parameters.

3-242

TEXAS
INSTRUMENTS

POST OFFICE BOX 225012 • DALLAS, TEXAS 75265

TYPES SN54LS56, SN54LS57, SN74LS56, SN74LS57 FREQUENCY DIVIDERS

electrical characteristics over recommended operating free-air temperature range (unless otherwise noted)

PARAMETER	TEST CONDITIONS†			SN54LS'		SN74LS'		UNIT
				MIN	TYP‡	MAX	MIN	
V _{IK}	V _{CC} = MIN, I _I = -18 mA			-1.5		-1.5		V
V _{OH}	V _{CC} = MIN, V _{IH} = 2 V, V _{IL} = MAX		I _{OH} = -1 mA	2.5	3.4	2.7	3.4	V
V _{OL}	V _{CC} = MIN, V _{IH} = 2 V, V _{IL} = MAX		I _{OL} = 8 mA	0.25	0.4	0.25	0.4	V
			I _{OL} = 16 mA			0.35	0.5	
I _I	CLKA, CLKB	V _{CC} = MAX		0.2		0.2		mA
	CLR			0.1		0.1		
I _{IH}	CLKA, CLKB	V _{CC} = MAX, V _I = 2.7 V		80		80		μA
	CLR			20		20		
I _{IL}	CLKA, CLKB	V _{CC} = MAX, CLR = 0 V, V _I = 0.4 V		-3.2		-3.2		mA
	CLR			-0.2		-0.2		
I _{OS} §	V _{CC} = MAX, CLR = 0 V, V _O = 0 V			-20	-100	-20	-100	mA
I _{CC}	V _{CC} = MAX, See Note 2			17	30	17	30	mA

† For conditions shown as MIN or MAX, use the appropriate value specified under recommended operating conditions.

‡ All typical values are at V_{CC} = 5 V, T_A = 25°C.

§ Not more than one output should be shorted at a time and the duration of the short-circuit should not exceed one second.

NOTE 2: I_{CC} is measured by applying 4.5 V to the CLR pin with all other inputs grounded and the outputs open.

switching characteristics, V_{CC} = 5 V, T_A = 25°C (see note 3)

PARAMETER	FROM (INPUT)	TO (OUTPUT)	TEST CONDITIONS	'LS56			'LS57			UNIT
				MIN	TYP	MAX	MIN	TYP	MAX	
f _{max}	CLKA	Q _A	R _L = 1 kΩ, C _L = 30 pF	15	25		15	25		MHz
f _{max}	CLKB	Q _B , Q _C		15	25		15	25		MHz
t _{PLH}	CLKB	Q _B		8	15		8	15		ns
t _{PHL}				14	25		14	25		ns
t _{PLH} *	CLKB	Q _C		18	30		18	30		ns
t _{PHL} *				24	35		24	35		ns
t _{PLH}	CLKA	Q _A		12	20		14	25		ns
t _{PHL}				14	25		18	30		ns
t _{PHL}	CLR	Q _A		17	30		17	30		ns
t _{PHL}	CLR	Q _B		17	30		17	30		ns
t _{PHL}	CLR	Q _C		17	30		17	30		ns

* Times measured from CLKB to output Q_C are taken with output Q_B unloaded.

NOTE 3: See General Information Section for load circuits and voltage waveforms.

3

TTL DEVICES

TYPES SN5460, SN54H60, SN7460, SN74H60 DUAL 4-INPUT EXPANDERS

REVISED DECEMBER 1983

- Package Options Include Plastic and Ceramic DIPs
- Dependable Texas Instruments Quality and Reliability

description

These devices contain two independent 4-input expanders. The '60 perform the Boolean function $X = ABCD$ when connected to X and \bar{X} inputs of SN5423/SN7423, SN5450/SN7450, or SN5453/SN7453. The 'H60 performs the same function when connected to X and \bar{X} inputs of SN54H50/SN74H50, SN54H53/SN74H53, or SN54H55/SN74H55.

The SN5460 and SN54H60 are characterized for operation over the full military temperature range of -55°C to 125°C . The SN7460 and SN74H60 are characterized for operation from 0°C to 70°C .

logic diagram (each gate)

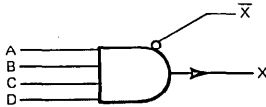

SN5460, SN54H60 ... J PACKAGE
SN7460, SN74H60 ... J OR N PACKAGE

(TOP VIEW)

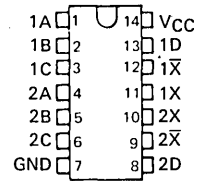

SN5460, SN54H60 ... W PACKAGE

(TOP VIEW)

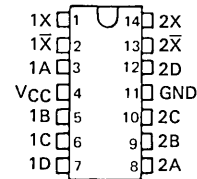

TTL DEVICES

PRODUCTION DATA

This document contains information current as of publication date. Products conform to specifications per the terms of Texas Instruments standard warranty. Production processing does not necessarily include testing of all parameters.

TEXAS
INSTRUMENTS

POST OFFICE BOX 225012 • DALLAS, TEXAS 75265

3-245

TYPES SN5460, SN54H60, SN7460, SN74H60 DUAL 4-INPUT EXPANDERS

schematics (each gate)

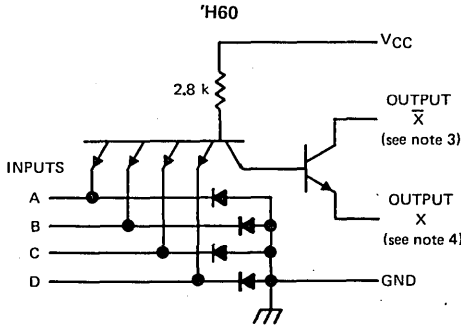
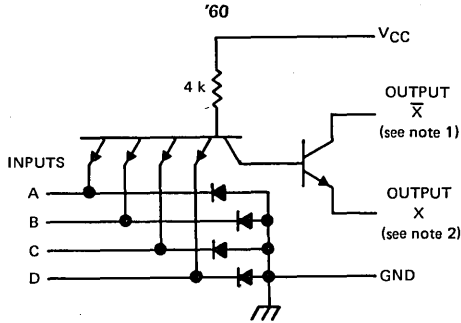

- NOTES: 1. Connect to \bar{X} input of '23, '50, or '53 circuit.
 2. Connect to X input of '23, '50, or '53 circuit.
 3. Connect to \bar{X} input of 'H50, 'H53, or 'H55 circuit.
 4. Connect to X input of 'H50, 'H53, or 'H55 circuit.
 Resistor values shown are nominal.

absolute maximum ratings over operating free-air temperature range (unless otherwise noted)

Supply voltage, V_{CC} (see Note 5).....	7 V
Input voltage:.....	5.5 V
Operating free-air temperature range: SN54'.....	-55°C to 125°C
SN74'.....	0°C to 70°C
Storage temperature range.....	-65°C to 150°C

NOTE 5: Voltage values are with respect to network ground terminal.

3

TTL DEVICES

recommended operating conditions

	SN5460			SN7460			UNIT
	MIN	NOM	MAX	MIN	NOM	MAX	
V _{CC} Supply voltage	4.5	5	5.5	4.75	5	5.25	V
V _{IH} High-level input voltage	2			2			V
V _{IL} Low-level input voltage	0.8			0.8			V
T _A Operating free-air temperature	-55			125			0 70 °C

The '23, '50, and '53 are designed for use with up to four '60 expanders.

electrical characteristics over recommended operating free-air temperature range (unless otherwise noted)

PARAMETER	TEST CONDITIONS†	SN5460		SN7460		UNIT
		MIN	TYP‡	MAX	MIN	
V _X (on)	V _{CC} = MIN, V _{IH} = 2 V, V _X = 1.1 V, I _X = 3.5 mA, T _A = -55°C			0.4		V
	V _{CC} = MIN, V _{IH} = 2 V, V _X = 1 V, I _X = 3.8 mA, T _A = 0°C			0.4		
I _X (on)	V _{CC} = MIN, V _{IH} = 2 V, V _X = 1.1 V, I _X = 0, T _A = -55°C	-0.3				mA
	V _{CC} = MIN, V _{IH} = 2 V, V _X = 1 V, I _X = 0, T _A = 0°C			-0.43		
I _X (off)	V _{CC} = MIN, V _{IL} = 0.8 V, V _X = 4.5 V, R _X = 1.2 kΩ, T _A = -55°C			0.15		mA
	V _{CC} = MIN, V _{IL} = 0.8 V, V _X = 4.5 V, R _X = 1.2 kΩ, T _A = 0°C			0.27		
I _I	V _{CC} = MAX, V _I = 5.5 V			1		1 mA
I _{IH}	V _{CC} = MAX, V _I = 2.4 V			40		40 μA
I _{IL}	V _{CC} = MAX, V _I = 0.4 V			-1.6		-1.6 mA
I _{CC} (on)	V _{CC} = MAX, V _I = 4.5 V, V _X = 0.85 V, I _X = 0	1.2 2.5		1.2 2.5		mA
I _{CC} (off)	V _{CC} = MAX, V _I = 0, V _X = 0.85 V, I _X = 0	2 4		2 4		mA

† For conditions shown as MIN or MAX, use the appropriate value specified under recommended operating conditions.

‡ All typical values are at V_{CC} = 5V, T_A = 25°C.

3
TTL DEVICES

TYPES SN54H60, SN74H60 DUAL 4-INPUT EXPANDERS

recommended operating conditions

	SN54H60			SN74H60			UNIT
	MIN	NOM	MAX	MIN	NOM	MAX	
V _{CC} Supply voltage	4.5	5	5.5	4.75	5	5.25	V
V _{IH} High-level input voltage	2			2			V
V _{IL} Low-level input voltage	0.8			0.8			V
T _A Operating free-air temperature	-55			125			°C

The 'H50, 'H53, and 'H55 are designed for use with up to four 'H60 expanders.

electrical characteristics over recommended operating free-air temperature range (unless otherwise noted)

PARAMETER	TEST CONDITIONS†	SN54H60			SN74H60			UNIT
		MIN	TYP‡	MAX	MIN	TYP‡	MAX	
V _{X(on)}	V _{CC} = MIN, V _{IH} = 2 V, V _X = 1.1 V, I _X = 5.85 mA, T _A = -55°C			0.4				V
	V _{CC} = MIN, V _{IH} = 2 V, V _X = 1 V, I _X = 6.3 mA, T _A = 0°C					0.4		
	V _{CC} = MAX, V _{IH} = 2 V, V _X = 1 V, I _X = 7.85 mA, T _A = 125°C			0.4				
	V _{CC} = MAX, V _{IH} = 2 V, V _X = 1 V, I _X = 7.4 mA, T _A = 70°C						0.4	
I _{X(on)}	V _{CC} = MIN, V _{IH} = 2 V, V _X = 1.1 V, I _X = 0, T _A = -55°C	-0.47						mA
	V _{CC} = MIN, V _{IH} = 2 V, V _X = 1 V, I _X = 0, T _A = 0°C				-0.6			
I _{X(off)}	V _{CC} = MIN, V _{IL} = 0.8 V, V _X = 4.5 V, R _X = 575 Ω, T _A = -55°C		0.32					mA
	V _{CC} = MIN, V _{IL} = 0.8 V, V _X = 4.5 V, R _X = 575 Ω, T _A = 0°C					0.57		
I _I	V _{CC} = MAX, V _I = 5.5 V			1			1	mA
I _{IH}	V _{CC} = MAX, V _I = 2.4 V			50			50	mA
I _{IL}	V _{CC} = MAX, V _I = 0.4 V			-2			-2	mA
I _{CC(on)}	V _{CC} = MAX, V _I = 4.5 V, V _X = 0.85 V, I _X = 0		1.9	3.5		1.9	3.5	mA
I _{CC(off)}	V _{CC} = MAX, V _I = 0, V _X = 0.85 V, I _X = 0		3	4.5		3	4.5	mA
C _X	V _{CC} , inputs, and X open, f = 1 MHz		5.4			5.4		pF

† For conditions shown as MIN or MAX, use the appropriate value specified under recommended operating conditions.

‡ All typical values are at V_{CC} = 5 V (except C_X), T_A = 25°C.

TYPES SN54H61, SN74H61 TRIPLE 3-INPUT EXPANDERS

REVISED DECEMBER 1983

- Package Options Include Plastic and Ceramic DIPs
- Dependable Texas Instruments Quality and Reliability

description

These devices contain three independent 3-input expanders. They perform the Boolean function $X = ABC$ when connected to X input of SN54H52/SN74H52.

The SN54H61 is characterized for operation over the full military temperature range of -55°C to 125°C . The SN74H61 is characterized for operation from 0°C to 70°C .

logic diagram (each gate)



SN54H61 . . . J PACKAGE
SN74H61 . . . J OR N PACKAGE
(TOP VIEW)

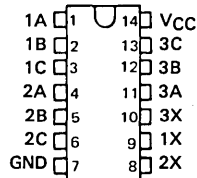

SN54H61 . . . W PACKAGE
(TOP VIEW)

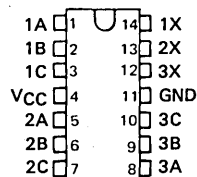

NC - No internal connection

schematic (each gate)

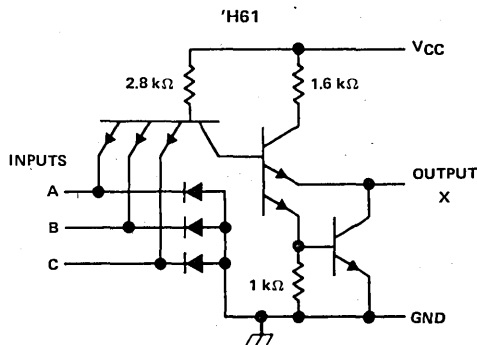

Resistor values shown are nominal.

PRODUCTION DATA

This document contains information current as of publication date. Products conform to specifications per the terms of Texas Instruments standard warranty. Production processing does not necessarily include testing of all parameters.

TEXAS
INSTRUMENTS

POST OFFICE BOX 225012 • DALLAS, TEXAS 75265

3

TTL DEVICES

TYPES SN54H61, SN74H61 TRIPLE 3-INPUT EXPANDERS

absolute maximum ratings over operating free-air temperature range (unless otherwise noted)

Supply voltage, V_{CC} (see Note 1)	7 V
Input voltage	5.5 V
Operating free-air temperature range: SN54H61	-55°C to 125°C
SN74H61	0°C to 70°C
Storage temperature range	-65°C to 150°C

NOTE 1: Voltage values are with respect to network ground terminal.

recommended operating conditions

	SN54H61			SN74H61			UNIT	
	MIN	NOM	MAX	MIN	NOM	MAX		
V_{CC} Supply voltage	4.5	5	5.5	4.75	5	5.25	V	
V_{IH} High-level input voltage	2			2			V	
V_{IL} Low-level input voltage	0.8			0.8			V	
T_A Operating free-air temperature	-55			0			70	°C

The 'H52 is designed for use with up to six 'H61 expanders.

electrical characteristics over recommended operating free-air temperature range (unless otherwise noted)

PARAMETER	TEST CONDITIONS †	SN54H61			SN74H61			UNIT
		MIN	TYP‡	MAX	MIN	TYP‡	MAX	
$V_{X(on)}$	$V_{CC} = \text{MIN}$, $V_{IH} = 2 \text{ V}$, $I_X = 4.5 \text{ mA}$, $T_A = \text{MIN}$	1						V
	$V_{CC} = \text{MIN}$, $V_{IH} = 2 \text{ V}$, $I_X = 5.35 \text{ mA}$, $T_A = \text{MIN}$				1			
$I_{X(off)}$	$V_{CC} = \text{MIN}$, $V_{IL} = 0.8 \text{ V}$, $V_X = 2.2 \text{ V}$, $T_A = \text{MAX}$	50			50			µA
I_I	$V_{CC} = 5.5 \text{ V}$, $V_I = 5.5 \text{ V}$	1			1			mA
I_{IH}	$V_{CC} = 5.5 \text{ V}$, $V_I = 2.4 \text{ V}$	50			50			µA
I_{IL}	$V_{CC} = 5.5 \text{ V}$, $V_I = 0.4 \text{ V}$	-2			-2			mA
$I_{CC(on)}$	$V_{CC} = 5.5 \text{ V}$, $V_I = 4.5 \text{ V}$	11 16			11 16			mA
$I_{CC(off)}$	$V_{CC} = 5.5 \text{ V}$, $V_I = 0 \text{ V}$	5 7			5 7			mA
C_X	V_{CC} and inputs open; $f = 1 \text{ MHz}$	5.4			5.4			pF

† For conditions shown as MIN or MAX, use the appropriate value specified under recommended operating conditions.

‡ All typical values are at $V_{CC} = 5 \text{ V}$ (except C_X), $T_A = 25^\circ\text{C}$.

3

TTL DEVICES

TYPES SN54H62, SN74H62 4-WIDE AND-OR EXPANDERS

REVISED DECEMBER 1983

- Package Options Include Plastic and Ceramic DIPs
- Dependable Texas Instruments Quality and Reliability

description

These devices contain 4-wide AND-OR expanders. In the J and N packages they perform the Boolean function $X = AB + CDE + FG + IJ$ when connected to X and \bar{X} inputs of SN54H50/SN74H50, SN54H53/SN74H53, or SN54H55/SN74H55. In a W package the function is $Y = ABC + DE + FG + HIJ$.

The SN54H62 is characterized for operation over the full military temperature range of -55°C to 125°C . The SN74H62 is characterized for operation from 0°C to 70°C .

SN54H62 . . . J PACKAGE
SN74H62 . . . J OR N PACKAGE
(TOP VIEW)

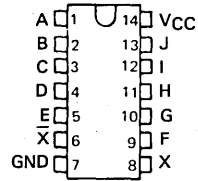

SN54H62 . . . W PACKAGE
(TOP VIEW)

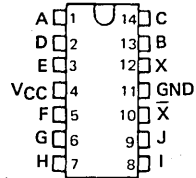

NC - No internal connection

logic diagrams

J OR N PACKAGE

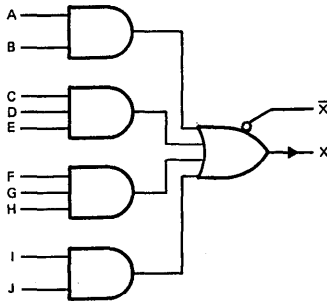

W PACKAGE

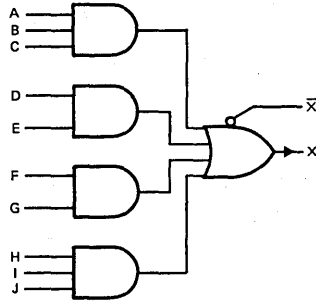

PRODUCTION DATA
This document contains information current as of publication date. Products conform to specifications per the terms of Texas Instruments standard warranty. Production processing does not necessarily include testing of all parameters.

**TEXAS
INSTRUMENTS**

POST OFFICE BOX 225012 • DALLAS, TEXAS 75265

3-251

3
TTL DEVICES

TYPES SN54H62, SN74H62 4-WIDE AND-OR EXPANDERS

schematic

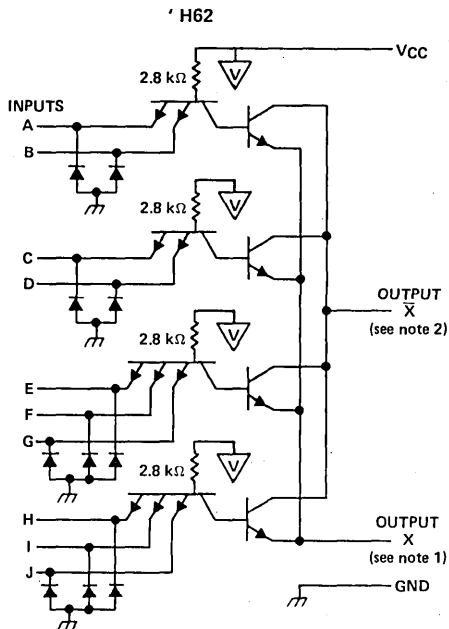

NOTES: 1. Connect to X input of 'H50, 'H53, or 'H55 circuit.
2. Connect to \bar{X} input of 'H50, 'H53, or 'H55 circuit.
Resistor values shown are nominal.

absolute maximum ratings over operating free-air temperature range (unless otherwise noted)

Supply voltage, V_{CC} (see Note 3)	7 V
Input voltage	5.5 V
Operating free-air temperature range: SN54H62	-55°C to 125°C
SN74H62	0°C to 70°C
Storage temperature range	-65°C to 150°C

NOTE 3: Voltage values are with respect to network ground terminal.

TYPES SN54H62, SN74H62 4-WIDE AND-OR EXPANDERS

recommended operating conditions

	SN54H62			SN74H62			UNIT
	MIN	NOM	MAX	MIN	NOM	MAX	
V_{CC} Supply voltage	4.5	5	5.5	4.75	5	5.25	V
V_{IH} High-level input voltage	2			2			V
V_{IL} Low-level input voltage	0.8			0.8			V
T_A Operating free-air temperature	-55			0			70 °C

electrical characteristics over recommended operating free-air temperature range (unless otherwise noted)

PARAMETER	TEST CONDITIONS†	SN54H62		SN74H62		UNIT
		MIN	TYP‡	MAX	MIN	
$V_{XX(on)}$	$V_{CC} = \text{MIN}$, $V_{IH} = 2 \text{ V}$, $V_X = 1.1 \text{ V}$, $I_{\bar{X}} = 5.85 \text{ mA}$, $T_A = -55^\circ\text{C}$			0.4		V
	$V_{CC} = \text{MIN}$, $V_{IH} = 2 \text{ V}$, $V_X = 1 \text{ V}$, $I_{\bar{X}} = 6.3 \text{ mA}$, $T_A = 0^\circ\text{C}$				0.4	
	$V_{CC} = \text{MAX}$, $V_{IH} = 2 \text{ V}$, $V_X = 1 \text{ V}$, $I_{\bar{X}} = 7.85 \text{ mA}$, $T_A = 125^\circ\text{C}$			0.4		
	$V_{CC} = \text{MAX}$, $V_{IH} = 2 \text{ V}$, $V_X = 1 \text{ V}$, $I_{\bar{X}} = 7.4 \text{ mA}$, $T_A = 70^\circ\text{C}$				0.4	
$I_X(on)$	$V_{CC} = \text{MIN}$, $V_{IH} = 2 \text{ V}$, $V_X = 1.1 \text{ V}$, $I_{\bar{X}} = 0$, $T_A = -55^\circ\text{C}$	-0.47				mA
	$V_{CC} = \text{MIN}$, $V_{IH} = 2 \text{ V}$, $V_X = 1 \text{ V}$, $I_{\bar{X}} = 0$, $T_A = 0^\circ\text{C}$			-0.6		
$I_X(off)$	$V_{CC} = \text{MIN}$, $V_{IL} = 0.8 \text{ V}$, $V_{\bar{X}} = 4.5 \text{ V}$, $R_X = 575 \Omega$, $T_A = -55^\circ\text{C}$		0.32			mA
	$V_{CC} = \text{MIN}$, $V_{IL} = 0.8 \text{ V}$, $V_{\bar{X}} = 4.5 \text{ V}$, $R_X = 575 \Omega$, $T_A = 0^\circ\text{C}$				0.57	
I_I	$V_{CC} = \text{MAX}$, $V_I = 5.5 \text{ V}$		1		1	mA
I_{IH}	$V_{CC} = \text{MAX}$, $V_I = 2.4 \text{ V}$		50		50	μA
I_{IL}	$V_{CC} = \text{MAX}$, $V_I = 0.4 \text{ V}$		-2		-2	mA
$I_{CC(on)}$	$V_{CC} = \text{MAX}$, $V_I = 4.5 \text{ V}$, $V_X = 0.85 \text{ V}$, $I_{\bar{X}} = 0$	3.8	7	3.8	7	mA
$I_{CC(off)}$	$V_{CC} = \text{MAX}$, $V_I = 0$, $V_X = 0.85 \text{ V}$, $I_{\bar{X}} = 0$	6	9	6	9	mA
$C_{\bar{X}}$	V_{CC} , inputs, and X open; $f = 1 \text{ MHz}$	6.0		6.0		pF

† For conditions shown as MIN or MAX, use the appropriate value specified under recommended operating conditions.

‡ All typical values are at $V_{CC} = 5 \text{ V}$ (except $C_{\bar{X}}$), $T_A = 25^\circ\text{C}$.

3

TTL DEVICES

TYPES SN54LS63, SN74LS63 HEX CURRENT-SENSING INTERFACE GATES WITH TOTEM-POLE OUTPUTS

REVISED DECEMBER 1983

- Translates Low-Level Input Current to Low-Level Output Voltage
- Translates High-Level Input Current to High-Level Output Voltage
- Interfaces to PLA's or Other Logic Elements that Source Current but Do Not Sink Current
- Operates from a Single 5 V Supply
- TTL Compatible
- Low Power Dissipation . . . 40 mW Typical.

description

Each of these Schottky-clamped interface gates is able to discriminate between low-level ($\leq 50\mu\text{A}$) and high-level ($\geq 200\mu\text{A}$) input currents.

The outputs are fabricated with standard Low-Power Schottky design rules and are compatible with all TTL families.

logic diagram (each gate)

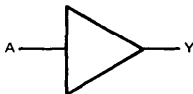

positive logic

$$Y = A$$

SN54LS63 . . . J OR W PACKAGE
SN74LS63 . . . D, J OR N PACKAGE
(TOP VIEW)

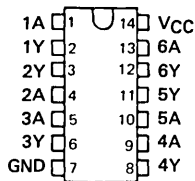

SN54LS63 . . . FK PACKAGE
SN74LS63 . . . FN PACKAGE
(TOP VIEW)

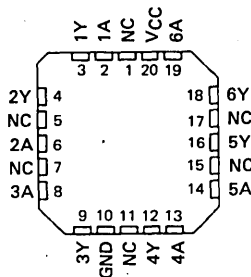

NC - No internal connection

schematic (each gate)

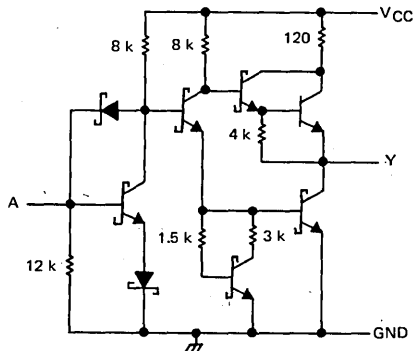

Resistor values shown are nominal and in ohms.

TYPES SN54LS63, SN74LS63 HEX CURRENT-SENSING INTERFACE GATES WITH TOTEM-POLE OUTPUTS

absolute maximum ratings over operating free-air temperature range (unless otherwise noted)

Supply voltage, V_{CC} (see Note 1)	7 V
Input voltage	7 V
Operating free-air temperature range: SN54LS63	-55°C to 125°C
SN74LS63	0°C to 70°C
Storage temperature range	-65°C to 150°C

NOTE 1: Voltage values are with respect to network ground terminal.

recommended operating conditions

	SN54LS63			SN74LS63			UNIT
	MIN	NOM	MAX	MIN	NOM	MAX	
V_{CC} Supply voltage	4.5	5	5.5	4.75	5	5.25	V
I_{OH} High-level output current			-400			-400	μ A
I_{OL} Low-level output current			4			8	mA
I_I Input current			1			1	mA
T_A Operating free-air temperature	-55		125	0		70	°C

electrical characteristics over recommended operating free-air temperature range (unless otherwise noted)

PARAMETER	TEST CONDITIONS†			SN54LS63		SN74LS63		UNIT	
				MIN	TYP‡	MAX	MIN		TYP‡
V_I Input voltage	$I_I = 50 \mu\text{A}$, $V_{CC} = \text{MIN}$	$V_{CC} = \text{MAX}$	$I_I = 200 \mu\text{A}$	0.35	1.05	1.75	0.6	1.05	1.6
				0.6	1.30	2	0.85	1.30	1.8
V_{OH} High-level output voltage	$V_{CC} = \text{MAX}$	$I_I = 200 \mu\text{A}$	$I_{OH} = -400 \mu\text{A}$	3.5	3.4	3.2	3.4	V	
V_{OL} Low-level output voltage	$V_{CC} = \text{MIN}$, $I_I = 50 \mu\text{A}$	$I_{OL} = 4 \text{ mA}$	$I_{OL} = 8 \text{ mA}$	0.25	0.4	0.25	0.4	V	
						0.35	0.5		
I_{OS} Short-circuit output current§	$V_{CC} = \text{MAX}$	$I_I = 600 \mu\text{A}$		-20	-100	-20	-100	mA	
I_{CC} Supply current	$V_{CC} = \text{MAX}$	See Note 2		8	16	8	16	mA	

†For conditions shown as MIN or MAX, use the appropriate value specified under recommended operating conditions.

‡All typical values are at $V_{CC} = 5 \text{ V}$, $T_A = 25^\circ\text{C}$.

§Not more than one output should be shorted at a time, and duration of output short circuit should not exceed one second.

NOTE 2: I_{CC} is measured with inputs and outputs open.

switching characteristics, $V_{CC} = 5 \text{ V}$, $T_A = 25^\circ\text{C}$

PARAMETER	TEST CONDITIONS	MIN	TYP	MAX	UNIT
t_{PLH} Propagation delay time, low-to-high-level output	$R_L = 2 \text{ k}\Omega$, $C_L = 15 \text{ pF}$		27	45	ns
t_{PHL} Propagation delay time, high-to-low-level output		15	25	ns	

PARAMETER MEASUREMENT INFORMATION

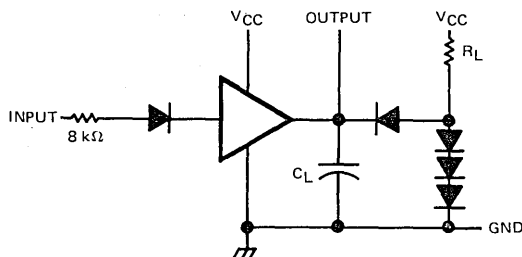

NOTES: a. C_L includes probe and jig capacitance
b. All diodes are IN3064 or equivalent.

TEST CIRCUIT

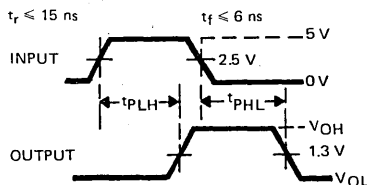

VOLTAGE WAVEFORMS

TYPES SN54S64, SN54S65, SN74S64, SN74S65

4-2-3-2 INPUT AND-OR-INVERT GATES

REVISED DECEMBER 1983

- Package Options Include Both Plastic and Ceramic Chip Carriers in Addition to Plastic and Ceramic DIPs
- Dependable Texas Instruments Quality and Reliability

description

These devices contain 4-2-3-2 input AND-OR-INVERT gates. They perform the Boolean function $Y = ABCD + EF + GHI + JK$. The 'S64 has totem-pole outputs and the 'S65 has open-collector outputs.

The SN54S64 and the SN54S65 are characterized for operation over the full military temperature range of -55°C to 125°C . The SN74S64 and the SN74S65 are characterized for operation from 0°C to 70°C .

logic diagram (each device)

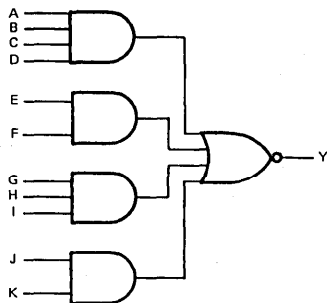

SN54S64, SN54S65 ... J OR W PACKAGE
SN74S64, SN74S65 ... D, J OR N PACKAGE
(TOP VIEW)

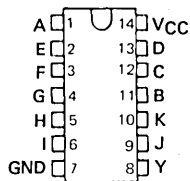

SN54S64, SN54S65 ... FK PACKAGE
SN74S64, SN74S65 ... FN PACKAGE
(TOP VIEW)

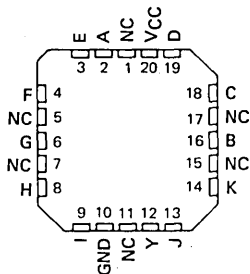

NC - No internal connection

3

TTL DEVICES

3-256

PRODUCTION DATA
This document contains information current as of publication date. Products conform to specifications per the terms of Texas Instruments standard warranty. Production processing does not necessarily include testing of all parameters.

TEXAS
INSTRUMENTS

POST OFFICE BOX 225012 • DALLAS, TEXAS 75265

TYPES SN54S64, SN54S65,
SN74S64, SN74S65
4-2-3-2 INPUT AND-OR-INVERT GATES

schematics (each gate)

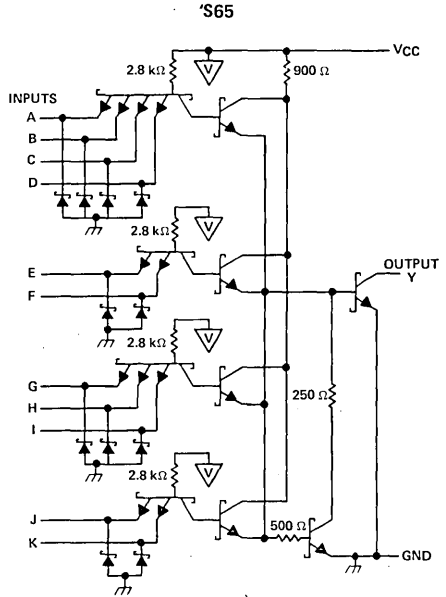
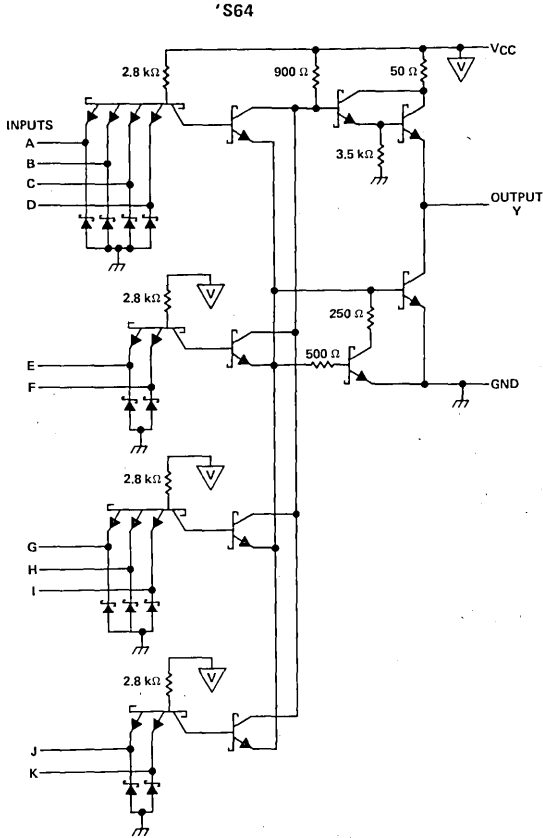

Resistor values shown are nominal and in ohms.

absolute maximum ratings over operating free-air temperature range (unless otherwise noted)

Supply voltage, V_{CC} (see Note 1)	7 V
Input voltage	5.5 V
Off-state output voltage, 'S65	7 V
Operating free-air temperature range: SN54'	-55°C to 125°C
SN74'	0°C to 70°C
Storage temperature range	-65°C to 150°C

NOTE 1: Voltage values are with respect to network ground terminal.



TTL DEVICES

TYPES SN54S64, SN74S64

4-2-3-2 INPUT AND-OR-INVERT GATES

recommended operating conditions

	SN54S64			SN74S64			UNIT
	MIN	NOM	MAX	MIN	NOM	MAX	
V _{CC} Supply voltage	4.5	5	5.5	4.75	5	5.25	V
V _{IH} High-level input voltage	2			2			V
V _{IL} Low-level input voltage			0.8			0.8	V
I _{OH} High-level output current			-1			-1	mA
I _{OL} Low-level output current			20			20	mA
T _A Operating free-air temperature	-55		125	0		70	°C

electrical characteristics over recommended operating free-air temperature range (unless otherwise noted)

PARAMETER	TEST CONDITIONS †	SN54S64			SN74S64			UNIT
		MIN	TYP ‡	MAX	MIN	TYP ‡	MAX	
V _{IK}	V _{CC} = MIN, I _I = -18 mA			-1.2			-1.2	V
V _{OH}	V _{CC} = MIN, V _{IL} = 0.8 V, I _{OH} = -1 mA	2.5	3.4		2.7	3.4		V
V _{OL}	V _{CC} = MIN, V _{IH} = 2 V, I _{OL} = 20 mA			0.5			0.5	V
I _I	V _{CC} = MAX, V _I = 5.5 V			1			1	mA
I _{IH}	V _{CC} = MAX, V _I = 2.7 V			50			50	μA
I _{IL}	V _{CC} = MAX, V _I = 0.5 V			-2			-2	mA
I _{OS} §	V _{CC} = MAX	-40		-100	-40		-100	mA
I _{CCH}	V _{CC} = MAX, V _I = 0 V		7	12.5		7	12.5	mA
I _{CCL}	V _{CC} = MAX, V _I = 4.5 V		8.5	16		8.5	16	mA

† For conditions shown as MIN or MAX, use the appropriate value specified under recommended operating conditions.

‡ All typical values are at V_{CC} = 5 V, T_A = 25°C.

§ Not more than one output should be shorted at a time, and the duration of the short-circuit should not exceed one second.

switching characteristics, V_{CC} = 5 V, T_A = 25°C (see note 2)

PARAMETER	FROM (INPUT)	TO (OUTPUT)	TEST CONDITIONS	MIN	TYP	MAX	UNIT	
t _{PLH}	Any	Y	R _L = 280 Ω, C _L = 15 pF		3.5	5.5	ns	
t _{PHL}					3.5	5.5	ns	
t _{PLH}			R _L = 280 Ω, C _L = 50 pF			5		ns
t _{PHL}						5.5		ns

NOTE 2: See General Information Section for load circuits and voltage waveforms.

TYPES SN54S65, SN74S65
4-2-3-2 INPUT AND-OR-INVERT GATES

recommended operating conditions

	SN54S65			SN74S65			UNIT
	MIN	NOM	MAX	MIN	NOM	MAX	
V _{CC} Supply voltage	4.5	5	5.5	4.75	5	5.25	V
V _{IH} High-level input voltage	2			2			V
V _{IL} Low-level input voltage			0.8			0.8	V
V _{OH} High-level output voltage			5.5			5.5	V
I _{OL} Low-level output current			20			20	mA
T _A Operating free-air temperature	-55		125	0		70	°C

electrical characteristics over operating free-air temperature range (unless otherwise noted)

PARAMETER	TEST CONDITIONS †	MIN	TYP ‡	MAX	UNIT	
V _{IK}	V _{CC} = MIN, I _I = -18 mA			-1.2	V	
I _{OH}	V _{CC} = MIN, V _{IL} = 0.8 V, V _{OH} = 5.5 V			0.25	mA	
V _{OL}	V _{CC} = MIN, V _{IH} = 2 V, I _{OL} = 20 mA			0.5	V	
I _I	V _{CC} = MAX, V _I = 5.5 V			1	mA	
I _{IH}	V _{CC} = MAX, V _I = 2.7 V			50	μA	
I _{IL}	V _{CC} = MAX, V _I = 0.5 V			-2	mA	
I _{CCH}	V _{CC} = MAX, V _I = 0 V			6	11	mA
I _{CCL}	V _{CC} = MAX, V _I = 4.5 V			8.5	16	mA

† For conditions shown as MIN or MAX, use the appropriate value specified under recommended operating conditions.

‡ All typical values are at V_{CC} = 5 V, T_A = 25°C.

switching characteristics, V_{CC} = 5 V, T_A = 25°C (see note 2)

PARAMETER	FROM (INPUT)	TO (OUTPUT)	TEST CONDITIONS	MIN	TYP	MAX	UNIT
t _{PLH}	Any	Y	R _L = 280 Ω, C _L = 15 pF	2	5	7.5	ns
t _{PHL}				2	5.5	8.5	ns
t _{PLH}			R _L = 280 Ω, C _L = 50 pF	8			ns
t _{PHL}				6.5			ns

NOTE 2: See General Information Section for load circuits and voltage waveforms.



TTL DEVICES

TYPES SN54LS68, SN54LS69, SN74LS68, SN74LS69 DUAL 4-BIT DECADE OR BINARY COUNTERS

REVISED DECEMBER 1983

- Heavy Duty Outputs I_{OL} Rated at 8mA/16 mA
- Counter One of Either 'LS68 or 'LS69 Has Individual Clicks for the A Flip-Flop
- Direct Clear for Each 4-Bit Counter
- Guaranteed Maximum Count Frequency is 50 MHz for 'LS69 and 40 MHz for 'LS68

description

Each of the 'LS68 and 'LS69 circuits contain two four-bit counters. The 'LS68 is a dual decade counter, while the 'LS69 is a dual binary counter. Counter number one of both the 'LS68 and 'LS69 has two clock pins. Clock 1 is for the A flip-flop, while clock 2 is for the B, C, D flip-flops. Counter one of the 'LS68 can perform bi-quinary counting. All $1Q_A$ outputs are rated with sufficient I_{OL} to drive clock 2 while maintaining a full fan-out.

All clocks trigger on the high-to-low transition of the clock pulse. All counters have direct overriding clear pins which, when low, reset Q_A , Q_B , Q_C , and Q_D low regardless of the state of the clock.

The SN54LS68 and SN54LS69 circuits are characterized for operation over the full military temperature range of -55°C to 125°C . The SN74LS68 and SN74LS69 circuits are characterized for operation from 0°C to 70°C

SN54LS68, SN54LS69 ... J PACKAGE
SN74LS68, SN74LS69 ... D, J OR N PACKAGE

(TOP VIEW)

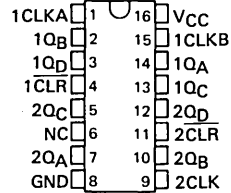

SN54LS68, SN54LS69 ... FK PACKAGE
SN74LS68, SN74LS69 ... FN PACKAGE

(TOP VIEW)

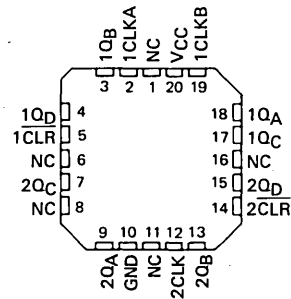

NC - No internal connection

PRODUCTION DATA
This document contains information current as of publication date. Products conform to specifications per the terms of Texas Instruments standard warranty. Production processing does not necessarily include testing of all parameters.

TEXAS
INSTRUMENTS

POST OFFICE BOX 225012 • DALLAS, TEXAS 75265

3-261

3
TTL DEVICES

TYPES SN54LS68, SN54LS69, SN74LS68, SN74LS69 DUAL 4-BIT DECADE OR BINARY COUNTERS

count sequence tables

'LS68 DECADE COUNTER BCD COUNT SEQUENCE

(See Note 1)

Applies to Counters 1 & 2

COUNT	OUTPUT			
	Q _D	Q _C	Q _B	Q _A
0	L	L	L	L
1	L	L	L	H
2	L	L	H	L
3	L	L	H	H
4	L	H	L	L
5	L	H	L	H
6	L	H	H	L
7	L	H	H	H
8	H	L	L	L
9	H	L	L	H

'LS68 DECADE COUNTER BI-QUINARY SEQUENCE

(See Note 2)

Applies to Counter 1 only

COUNT	OUTPUT			
	Q _A	Q _D	Q _C	Q _B
0	L	L	L	L
1	L	L	L	H
2	L	L	H	L
3	L	L	H	H
4	L	H	L	L
5	H	L	L	L
6	H	L	L	H
7	H	L	H	L
8	H	L	H	H
9	H	H	L	L

'LS69 BINARY COUNTER BCD COUNT SEQUENCE

(See Note 3)

Applies to Counters 1 & 2

COUNT	OUTPUT			
	Q _D	Q _C	Q _B	Q _A
0	L	L	L	L
1	L	L	L	H
2	L	L	H	L
3	L	L	H	H
4	L	H	L	L
5	L	H	L	H
6	L	H	H	L
7	L	H	H	H
8	H	L	L	L
9	H	L	L	H
10	H	L	H	L
11	H	L	H	H
12	H	H	L	L
13	H	H	L	H
14	H	H	H	L
15	H	H	H	H

- NOTES: 1. Output 1Q_A is connected to 1CLK2 for BCD count.
 2. Output 1Q_A is connected to 1CLK1 for bi-quinary count.
 3. Output 1Q_A is connected to 1CLK2 for binary count.

3

schematics of inputs and outputs

TTL DEVICES

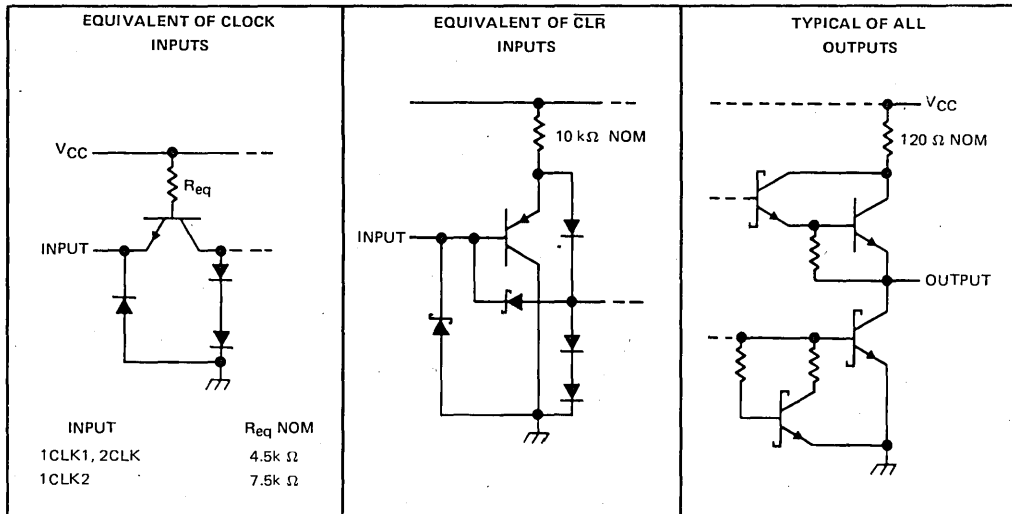

TYPES SN54LS68, SN54LS69, SN74LS68, SN74LS69
DUAL 4-BIT DECADE OR BINARY COUNTERS

logic diagrams

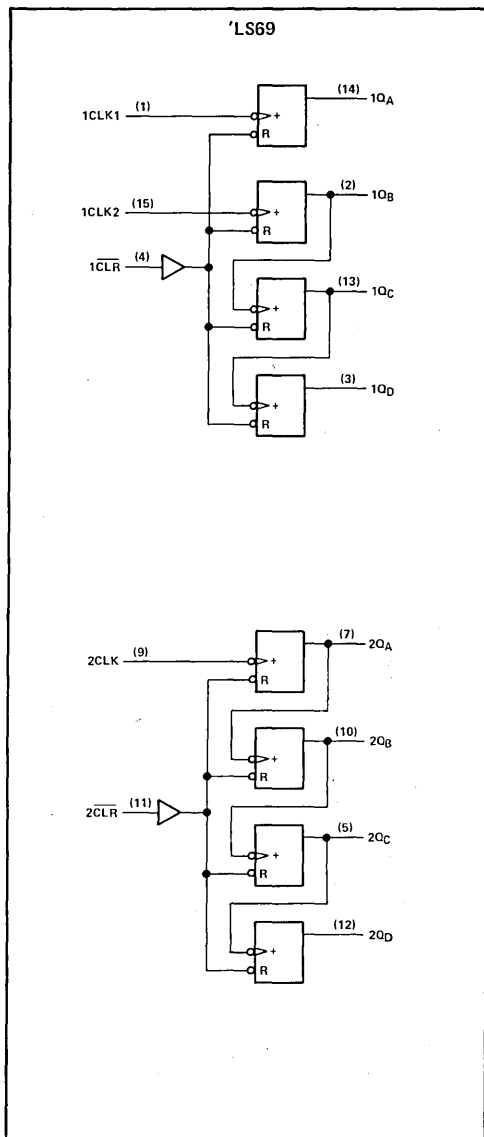
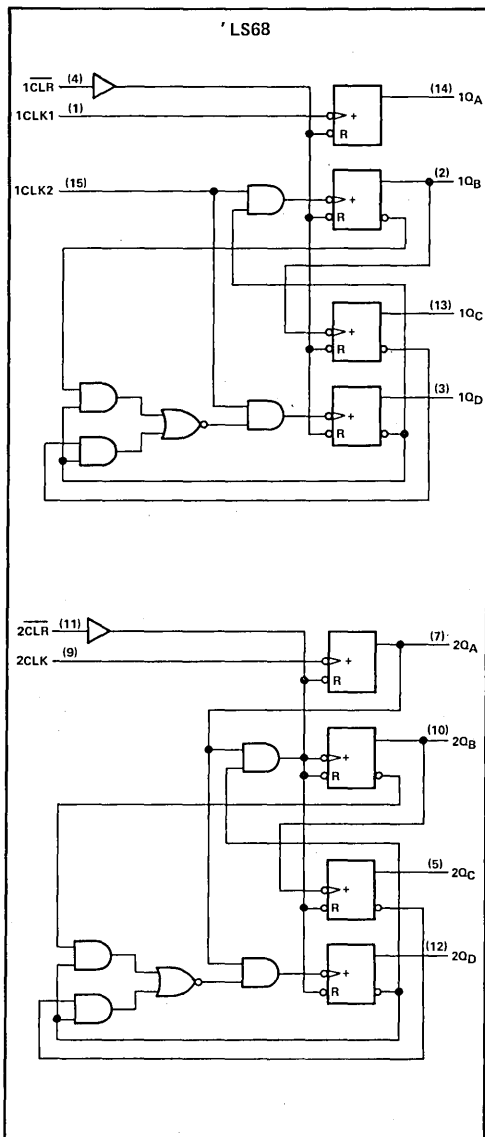

Pin numbers shown on logic notation are for D, J or N packages.

3

TTL DEVICES

TYPES SN54LS68, SN54LS69, SN74LS68, SN74LS69

DUAL 4-BIT DECADE OR BINARY COUNTERS

absolute maximum ratings over operating free-air temperature range (unless otherwise noted)

Supply voltage, V_{CC} (see Note 4)	7 V
Input voltage: Clear inputs	7 V
Clock inputs	5.5 V
Operating free-air temperature range: SN54LS'	-55° C to 125° C
SN74LS'	0° C to 70° C
Storage temperature range	-65° C to 150° C

NOTE 4: Voltage values are with respect to network ground terminal.

recommended operating conditions

		SN54LS'			SN74LS'			UNIT
		MIN	NOM	MAX	MIN	NOM	MAX	
V_{CC}	Supply voltage	4.5	5	5.5	4.75	5	5.25	V
V_{IH}	High-level input voltage	2			2			V
V_{IL}	Low-level input voltage	0.7			0.8			V
I_{OH}	High-level output current	-1			-1			mA
I_{OL}	Low-level output current	8			16			mA
f_{max}	Clock frequency	1CLK1	0	50	0	50	MHz	
		1CLK2	'LS68	0	20	0		20
			'LS69	0	25	0		25
		2CLK	'LS68	0	40	0		40
'LS69	0		50	0	50			
t_w	Pulse width	1CLK1	10		10		ns	
		1CLK2	'LS68	25		25		
			'LS69	20		20		
		2CLK	'LS68	13		13		
			'LS69	10		10		
CLEAR	15		15					
t_{SU}	Clear inactive-state set-up time	25		25		ns		
T_A	Operating free-air temperature	-55		125		0	70	°C

TYPES SN54LS68, SN54LS69, SN74LS68, SN74LS69
DUAL 4-BIT DECADE OR BINARY COUNTERS

electrical characteristics over recommended operating free-air temperature range (unless otherwise noted)

PARAMETER	TEST CONDITIONS†	SN54LS'		SN74LS'		UNIT
		MIN	TYP‡	MAX	MIN	
V _{IK}	V _{CC} = MIN, I _I = -18 mA			-1.5		V
V _{OH}	V _{CC} = MIN, V _{IH} = 2 V, V _{IL} = MAX, I _{OH} = -1 mA	2.5	3.4	2.7	3.4	V
V _{OL}	V _{CC} = MIN, V _{IH} = 2 V, V _{IL} = MAX, I _{OL} = 8 mA	0.25		0.25	0.4	V
				0.35	0.5	
I _I	V _{CC} = MAX, V _I = 5.5 V			0.1		mA
	V _{CC} = MAX, V _I = 7 V			0.1		
I _{IH}	V _{CC} = MAX, V _I = 2.7 V			40		μA
				20		
I _{IL}	V _{CC} = MAX, V _I = 0.4 V	1CLK1, 2CLK		-2		mA
		1CLK2		-1.2		
		CLR		-0.2		
I _{OS} §	V _{CC} = MAX, V _O = 0 V	-20	-100	-20	-100	mA
I _{CC}	V _{CC} = MAX, see Note 5	36 54		36 54		mA

† For conditions shown as MIN or MAX, use the appropriate value specified under recommended operating conditions.

‡ All typical values are at V_{CC} = 5 V, T_A = 25°C.

§ Not more than one output should be shorted at a time, and duration of the short-circuit should not exceed one second.

NOTE 5: I_{CC} is measured with all inputs grounded and all outputs open.

switching characteristics, V_{CC} = 5 V, T_A = 25°C (see note 6)

PARAMETER	FROM (INPUT)	TO (OUTPUT)	TEST CONDITIONS	'LS68			'LS69			UNIT
				MIN	TYP	MAX	MIN	TYP	MAX	
t _{max}	1CLK1	1Q _A	R _L = 1 kΩ, C _L = 30 pF	50	70		50	70		MHz
t _{max}		1Q _B , 1Q _C , 1Q _D		20	30		25	35		MHz
t _{max}		2Q _A , 2Q _B , 2Q _C , 2Q _D		40	60		50	70		MHz
t _{PLH}	1CLK1	1Q _A		7	11		7	11		ns
t _{PHL}				14	21		14	21		
t _{PLH}	1CLK2	1Q _B		8	12		7	11		ns
t _{PHL}				12	18		14	21		
t _{PLH}		1Q _C		15	23		16	24		
t _{PHL}				21	32		21	32		
t _{PLH}		1Q _D		8	12		25	38		
t _{PHL}				13	20		30	45		
t _{PLH}	2CLK	2Q _A		7	11		7	11		ns
t _{PHL}				14	21		14	21		
t _{PLH}		2Q _B		16	24		14	21		
t _{PHL}				19	29		19	29		
t _{PLH}		2Q _C		23	35		23	35		
t _{PHL}				27	40		27	40		
t _{PLH}		2Q _D		16	24		32	48		
t _{PHL}				19	29		36	54		
t _{PHL}	Any CLR	Any Q		20	30		20	30		ns

NOTE 6: See General Information Section for load circuits and voltage waveforms.



TTL DEVICES

TYPES SN5470, SN7470 AND-GATED J-K POSITIVE-EDGE-TRIGGERED FLIP-FLOPS WITH PRESET AND CLEAR

REVISED DECEMBER 1983

- Package Options Include Plastic and Ceramic DIPs
- Dependable Texas Instruments Quality and Reliability

description

These monolithic, edge-triggered J-K flip-flops feature gated inputs, direct clear and preset inputs, and complementary Q and \bar{Q} outputs. Input information is transferred to the outputs on the positive edge of the clock pulse.

Direct-coupled clock triggering occurs at a specific voltage level of the clock pulse, and after the clock input threshold voltage has been passed, the gated inputs are locked out.

These flip-flops are ideally suited for medium-to-high-speed applications and can result in a significant saving in system power dissipation and package count where input gating is required.

The SN5470 is characterized for operation over the full military temperature range of -55°C to 125°C . The SN7470 is characterized for operation from 0°C to 70°C .

FUNCTION TABLE

INPUTS					OUTPUTS	
PRE	CLR	CLK	J	K	Q	\bar{Q}
L	H	L	X	X	H	L
H	L	L	X	X	L	H
L	L	X	X	X	L [†]	L [†]
H	H	↑	L	L	Q ₀	Q ₀
H	H	↑	H	L	H	L
H	H	↑	L	H	L	H
H	H	↑	H	H	TOGGLE	
H	H	L	X	X	Q ₀	Q ₀

If inputs J and K are not used, they must be grounded. Preset or clear function can occur only when the clock input is low.

[†]This configuration is nonstable; that is, it will not persist when preset and clear inputs return to their inactive (high) level.

SN5470 ... J PACKAGE
SN7470 ... J OR N PACKAGE
(TOP VIEW)

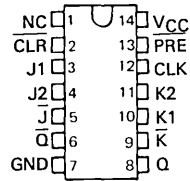

SN5470 ... W PACKAGE
(TOP VIEW)

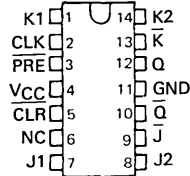

NC - No internal connection

logic symbol

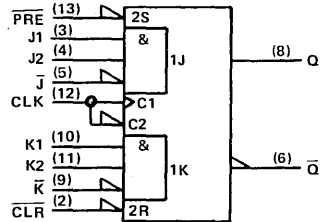

Pin numbers shown are for J and N packages only.

positive logic

$$J = J1 \cdot J2 \cdot \bar{J}$$

$$K = K1 \cdot K2 \cdot \bar{K}$$

PRODUCTION DATA
This document contains information current as of publication date. Products conform to specifications per the terms of Texas Instruments standard warranty. Production processing does not necessarily include testing of all parameters.

TEXAS
INSTRUMENTS

POST OFFICE BOX 225012 • DALLAS, TEXAS 75265

3

TTL DEVICES

TYPES SN5470, SN7470
AND-GATED J-K POSITIVE-EDGE-TRIGGERED
FLIP-FLOPS WITH PRESET AND CLEAR

logic diagram

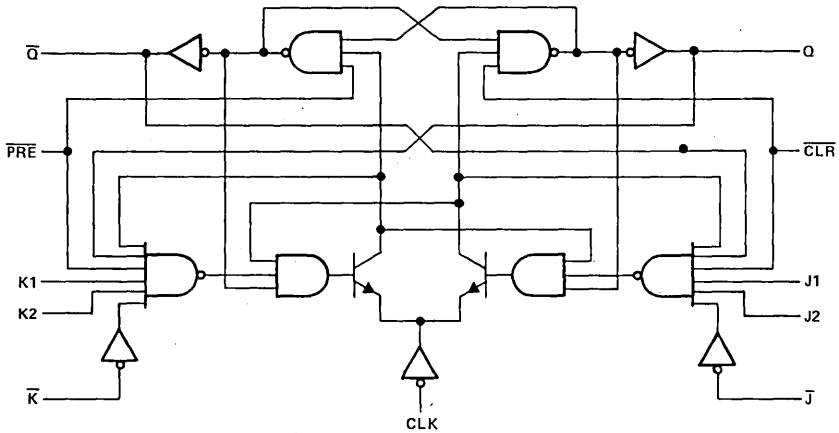

'70-GATED J-K WITH CLEAR AND PRESET

schematics of input and outputs

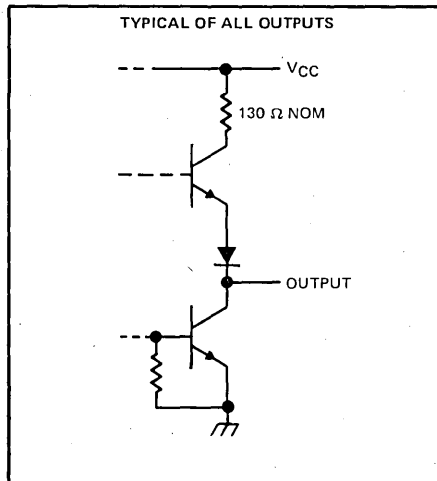
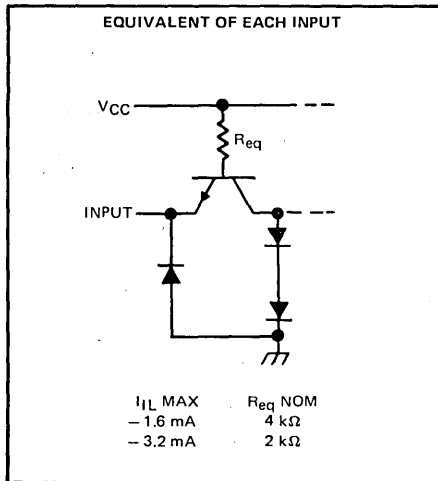

TYPES SN5470, SN7470 AND-GATED J-K POSITIVE-EDGE-TRIGGERED FLIP-FLOPS WITH PRESET AND CLEAR

absolute maximum ratings over operating free-air temperature range (unless otherwise noted)

Supply voltage, V_{CC} (see Note 1)7 V
Input voltage	5.5 V
Operating free-air temperature: SN5470	-55°C to 125°C
SN7470	0°C to 70°C
Storage temperature range	-65°C to 150°C

NOTE 1: All voltage values are with respect to network ground terminal.

recommended operating conditions

		SN5470			SN7470			UNIT
		MIN	NOM	MAX	MIN	NOM	MAX	
V_{CC}	Supply voltage	4.5	5	5.5	4.75	5	5.25	V
V_{IH}	High-level input voltage	2			2			V
V_{IL}	Low-level input voltage				0.8			V
I_{OH}	High-level output current				-0.4			mA
I_{OL}	Low-level output current				16			mA
t_w	Pulse duration	CLK high		20	20		ns	
		CLK low		30	30			
		PRE or CLR low		25	25			
t_{su}	Setup time before CLK †	20			20			ns
t_h	Hold time-Data after CLK †	5			5			ns
T_A	Operating free-air temperature	-55		125	0		70	°C

† The arrow indicates the edge of the clock pulse used for reference: † for the rising edge, ‡ for the falling edge.

electrical characteristics over recommended operating free-air temperature range (unless otherwise noted)

PARAMETER	TEST CONDITIONS†	SN5470			SN7470			UNIT
		MIN	TYP‡	MAX	MIN	TYP‡	MAX	
V_{IK}	$V_{CC} = \text{MIN}, I_I = -12 \text{ mA}$	-1.5			-1.5			V
V_{OH}	$V_{CC} = \text{MIN}, V_{IH} = 2 \text{ V}, V_{IL} = 0.8 \text{ V}, I_{OH} = -0.4 \text{ mA}$	2.4	3.4		2.4	3.4		V
V_{OL}	$V_{CC} = \text{MIN}, V_{IH} = 2 \text{ V}, V_{IL} = 0.8 \text{ V}, I_{OL} = 16 \text{ mA}$		0.2	0.4		0.2	0.4	V
I_I	$V_{CC} = \text{MAX}, V_I = 5.5 \text{ V}$	1			1			mA
I_{IH}	PRE or CLR	80			80			μA
	All other	40			40			
I_{IL}	PRE or CLR*	-3.2			-3.2			mA
	All other	-1.6			-1.6			
$I_{OS} \S$	$V_{CC} = \text{MAX}$	-20		-57	-18		-57	mA
I_{CC}	$V_{CC} = \text{MAX},$ See Note 2	13		26	13		26	mA

† For conditions shown as MIN or MAX, use the appropriate value specified under recommended operating conditions.

‡ All typical values are at $V_{CC} = 5 \text{ V}, T_A = 25^\circ\text{C}$.

§ Not more than one output should be shorted at a time.

* Clear is tested with preset high and preset is tested with clear high.

NOTE 2: With all outputs open, I_{CC} is measured with the Q and \bar{Q} outputs high in turn. At the time of measurement, the clock input is at 4.5 V.

3

TTL DEVICES

TYPES SN5470, SN7470
AND-GATED J-K POSITIVE-EDGE-TRIGGERED
FLIP-FLOPS WITH PRESET AND CLEAR

switching characteristics, $V_{CC} = 5\text{ V}$, $T_A = 25^\circ\text{C}$ (see note 3)

PARAMETER†	FROM (INPUT)	TO (OUTPUT)	TEST CONDITIONS	MIN	TYP	MAX	UNIT	
f_{max}			$R_L = 400\ \Omega$, $C_L = 15\ \text{pF}$	20	35		MHz	
t_{PLH}	\overline{PRE} or \overline{CLR}	Q or \overline{Q}				50	ns	
t_{PHL}						50	ns	
t_{PLH}	CLK	Q or \overline{Q}				27	50	ns
t_{PHL}						18	50	ns

† f_{max} = maximum clock frequency; t_{PLH} = propagation delay time, low-to-high level output;

t_{PHL} = propagation delay time, high-to-low level output.

NOTE 3: See General Information Section for load circuits and voltage waveforms.

TYPES SN54H71, SN74H71 AND-OR GATED J-K MASTER-SLAVE FLIP-FLOPS WITH PRESET

REVISED DECEMBER 1983

- Package Options Include Plastic and Ceramic DIPs
- Dependable Texas Instruments Quality and Reliability

description





These J-K flip-flops are based on the master-slave principle. The AND-OR gate inputs for entry into the master section are controlled by the clock pulse. The clock pulse also regulates the circuitry which connects the master and slave sections. The sequence of operation is as follows:

1. Isolate slave from master
2. Enter information from AND-OR gate inputs to master
3. Disable AND-OR gate inputs
4. Transfer information from master to slave.

Logical state of J and K inputs must not be allowed to change when the clock pulse is in a high state.

The SN54H71 is characterized for operation over the full military temperature range of -55°C to 125°C . The SN74H71 is characterized for operation from 0°C to 70°C .

FUNCTION TABLE

INPUTS				OUTPUTS	
PRE	CLK	J	K	Q	\bar{Q}
L	X	X	X	H	L
H		L	L	Q_0	\bar{Q}_0
H		H	L	H	L
H		L	H	L	H
H		H	H	TOGGLE	

SN54H71 ... J PACKAGE
SN74H71 ... J OR N PACKAGE
(TOP VIEW)

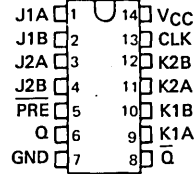

SN54H71 ... W PACKAGE
(TOP VIEW)

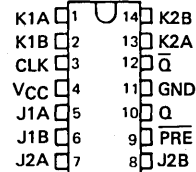

logic symbol

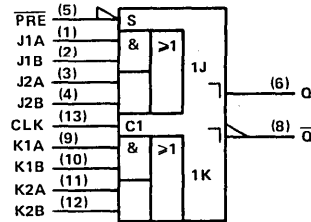

Pin numbers shown are for J and N packages.

positive logic

$$J = (J1A \cdot J1B) + (J2A \cdot J2B)$$

$$K = (K1A \cdot K1B) + (K2A \cdot K2B)$$

PRODUCTION DATA
This document contains information current as of publication date. Products conform to specifications per the terms of Texas Instruments standard warranty. Production processing does not necessarily include testing of all parameters.

**TEXAS
INSTRUMENTS**

POST OFFICE BOX 225012 • DALLAS, TEXAS 75265

3-271

3
TTL DEVICES

TYPES SN54H71, SN74H71
AND-OR GATED J-K MASTER-SLAVE
FLIP-FLOPS WITH PRESET

logic diagram

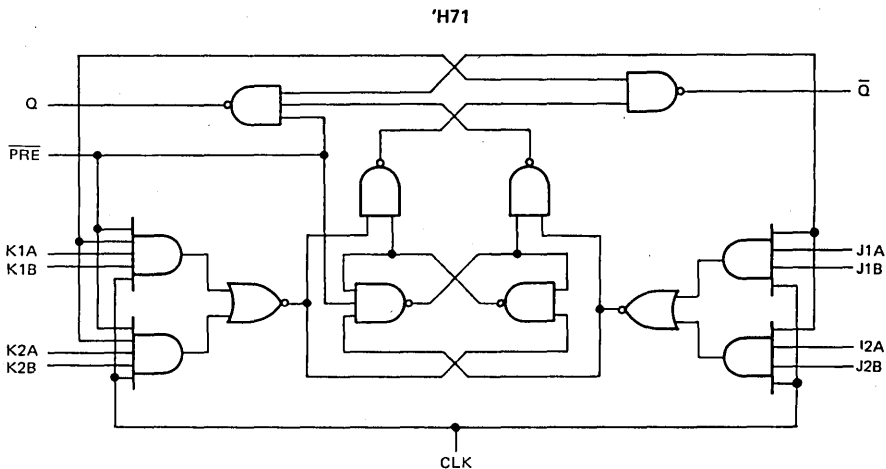

schematics of input and outputs

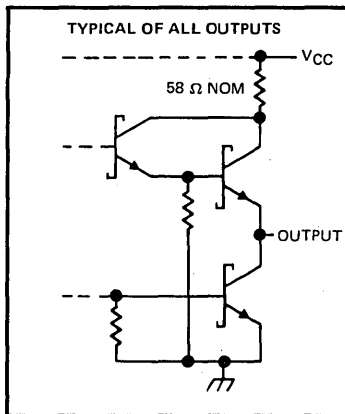
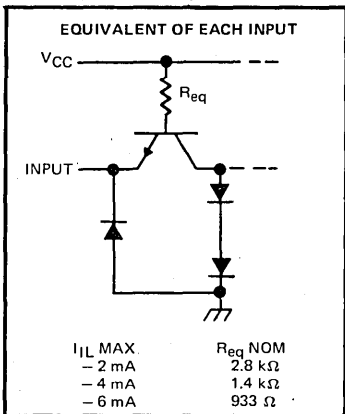

3

TTL DEVICES

TYPES SN54H71, SN74H71 AND-OR GATED J-K MASTER-SLAVE FLIP-FLOPS WITH PRESET

absolute maximum ratings over operating free-air temperature range (unless otherwise noted)

Supply voltage, V_{CC} (see Note 1)	7 V
Input voltage	5.5 V
Operating free-air temperature: SN54H71	-55°C to 125°C
SN74H71	0°C to 70°C
Storage temperature range	-65°C to 150°C

NOTE 1: Voltage values are with respect to network ground terminal.

recommended operating conditions

		SN54H71			SN74H71			UNIT
		MIN	NOM	MAX	MIN	NOM	MAX	
V_{CC}	Supply voltage	4.5	5	5.5	4.75	5	5.75	V
V_{IH}	High-level input voltage	2			2			V
V_{IL}	Low-level input voltage	0.8			0.8			V
I_{OH}	High-level output current	-0.5			-0.5			mA
I_{OL}	Low-level output current	20			20			mA
t_w	Pulse duration	CLK high		12	12		ns	
		CLK low		28	28			
		PRE low		16	16			
t_{su}	Setup time-before CLK \dagger	Data high or low		0	0		ns	
t_h	Hold time-data after CLK \dagger			0	0		ns	
T_A	Operating free-air temperature	-55	125		0	70		°C

\dagger The arrow indicates the edge of the clock pulse used for reference: \uparrow for the rising edge, \downarrow for the falling edge.

electrical characteristics over recommended operating free-air temperature range (unless otherwise noted)

PARAMETER	TEST CONDITIONS †	SN54H71		SN74H71		UNIT
		MIN	TYP \ddagger	MAX	MIN	
V_{IK}	$V_{CC} = \text{MIN}, I_I = -8 \text{ mA}$	-1.5		-1.5		V
V_{OH}	$V_{CC} = \text{MIN}, V_{IH} = 2 \text{ V}, V_{IL} = 0.8 \text{ V}, I_{OH} = -0.5 \text{ mA}$	2.4	3.4	2.4	3.4	V
V_{OL}	$V_{CC} = \text{MIN}, V_{IH} = 2 \text{ V}, V_{IL} = 0.8 \text{ V}, I_{OL} = 20 \text{ mA}$	0.2 0.4		0.2 0.4		V
I_I	$V_{CC} = \text{MAX}, V_I = 5.5 \text{ V}$	1		1		mA
I_{IH}	J or K	50		50		μA
	PRE	150		150		
	CLK	100		100		
I_{IL}	J or K	-2		-2		mA
	PRE	-6		-6		
	CLK	-4		-4		
I_{OS}^\S	$V_{CC} = \text{MAX}$	-40	-100	-40	-100	mA
I_{CC}	$V_{CC} = \text{MAX}$, see Note 2	19 30		19 30		mA

† For conditions shown as MIN or MAX, use the appropriate value specified under recommended operating conditions.

\ddagger All typical values are at $V_{CC} = 5 \text{ V}, T_A = 25^\circ\text{C}$.

§ Not more than one output should be shorted at a time, and duration of the short-circuit should not exceed one second.

NOTE 2: With all outputs open, I_{CC} is measured with the Q and \bar{Q} outputs high in turn. At the time of measurement, the clock input is grounded.

3

TTL DEVICES

TYPES SN54H71, SN74H71
 AND-OR GATED J-K MASTER-SLAVE
 FLIP-FLOPS WITH PRESET

switching characteristics, $V_{CC} = 5\text{ V}$, $T_A = 25^\circ\text{C}$ (see note 3)

PARAMETER	FROM (INPUT)	TO (OUTPUT)	TEST CONDITIONS	MIN	TYP	MAX	UNIT
f_{\max}			$R_L = 280\ \Omega$, $C_L = 25\ \mu\text{F}$	25	30		MHz
t_{PLH}	$\overline{\text{PRE}}$	Q			6	13	ns
t_{PHL}		\overline{Q}			12	24	ns
t_{PLH}	CLK	Q or \overline{Q}			14	21	ns
t_{PHL}					22	27	ns

NOTE 3: See General Information Section for load circuits and voltage waveforms.

TYPE SN54L71
AND-GATED R-S MASTER-SLAVE
FLIP-FLOPS WITH PRESET AND CLEAR
 REVISED DECEMBER 1983

- Dependable Texas Instruments Quality and Reliability

SN54L71 ... J PACKAGE
 (TOP VIEW)

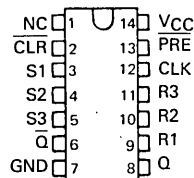

NC - No internal connection

description

This R-S flip-flop circuit is based on the master-slave principle. The AND gate inputs for entry into the master section are controlled by the clock pulse. The clock pulse also regulates the state of the coupling transistors which connect the master and slave sections. The sequence of operation is as follows:

1. Isolate slave from master
2. Enter information from AND gate inputs to master
3. Disable AND gate inputs
4. Transfer information from master to slave

The SN54L71 is characterized for operation over the full military temperature range of -55°C to 125°C.

logic symbol

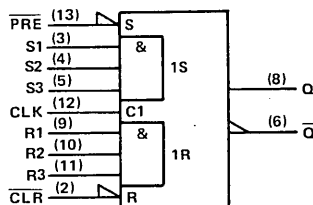

Pin numbers shown are for J packages.

FUNCTION TABLE

INPUTS					OUTPUTS	
PRE	CLR	CLK	S	R	Q	Q̄
L	H	X	X	X	H	L
H	L	X	X	X	L	H
L	L	X	X	X	H [†]	H [†]
H	H		L	L	Q ₀	Q̄ ₀
H	H		H	L	H	L
H	H		L	H	L	H
H	H		H	H	INDETERMINATE	

† This configuration is nonstable; that is, it will not persist when preset and clear inputs return to their inactive (high) level.

positive logic

$$R = R1 \cdot R2 \cdot R3$$

$$S = S1 \cdot S2 \cdot S3$$

3
TTL DEVICES

**TYPE SN54L71
AND-GATED R-S MASTER-SLAVE
FLIP-FLOPS WITH PRESET AND CLEAR**

logic diagram

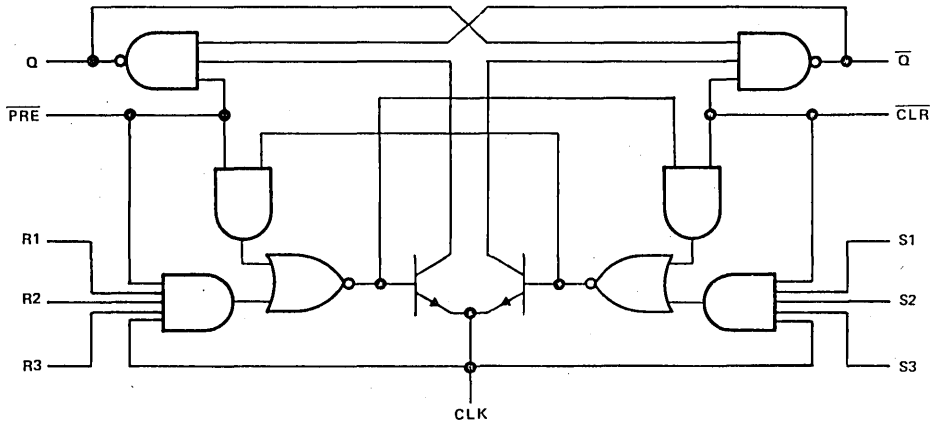

schematics of input and outputs

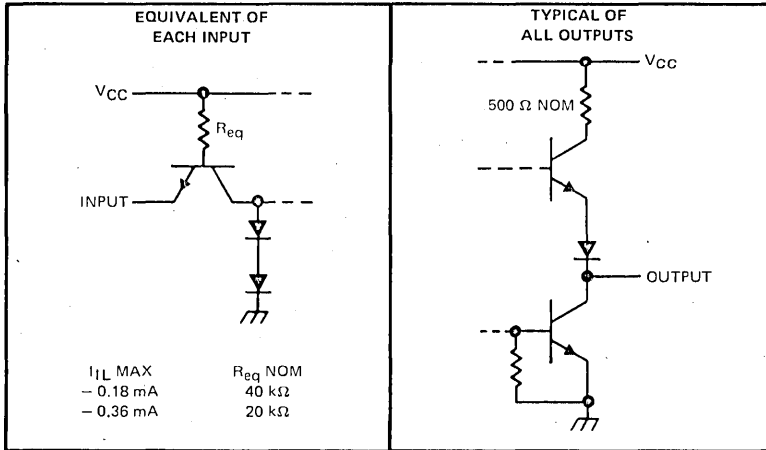

TYPE SN54L71 AND-GATED R-S MASTER-SLAVE FLIP-FLOPS WITH PRESET AND CLEAR

absolute maximum ratings over operating free-air temperature range (unless otherwise noted)

Supply voltage, V_{CC} (see Note 1)	7 V
Input voltage	5.5 V
Operating free-air temperature	- 55°C to 125°C
Storage temperature range	- 65°C to 150°C

NOTE 1: Voltage values are with respect to network ground terminal.

recommended operating conditions

		MIN	NOM	MAX	UNIT
V_{CC}	Supply voltage	4.5	5	5.5	V
V_{IH}	High-level input voltage	2			V
V_{IL}	Low-level input voltage	Clock input		0.6	V
		All other inputs		0.7	
I_{OH}	High-level output current	- 0.1			mA
I_{OL}	Low-level output current	2			mA
t_w	Pulse duration	CLK high or low		200	ns
		PRE or CLR low		100	
t_{su}	Setup time before CLK \uparrow	0			ns
t_h	Hold time-data after CLK \downarrow	0			ns
T_A	Operating free-air temperature	- 55		125	°C

electrical characteristics over recommended operating free-air temperature range (unless otherwise noted)

PARAMETER		TEST CONDITIONS †				MIN	TYP‡	MAX	UNIT
V_{OH}		$V_{CC} = \text{MIN.}$	$V_{IH} = 2 \text{ V.}$	$V_{IL} = \text{MAX.}$	$I_{OH} = - 0.1 \text{ mA}$	2.4	3.3		V
V_{OL}		$V_{CC} = \text{MIN.}$	$V_{IH} = 2 \text{ V.}$	$V_{IL} = \text{MAX.}$	$I_{OL} = 2 \text{ mA}$	0.15	0.3		V
I_I	R or S	$V_{CC} = \text{MAX.}, V_I = 5.5 \text{ V}$					0.1		mA
	All other						0.2		
I_{IH}	R or S	$V_{CC} = \text{MAX.}, V_I = 2.4 \text{ V}$					10		μA
	PRE or CLR						20		
	CLK						- 0.2		
I_{IL}	R or S	$V_{CC} = \text{MAX.}, V_I = 0.3 \text{ V}$					- 0.18		mA
	All other						- 0.36		
I_{OS}		$V_{CC} = \text{MAX.}$				- 3	- 15		mA
I_{CC}		$V_{CC} = \text{MAX.}$ See Note 2					0.76	1.44	mA

† For conditions shown as MIN or MAX, use the appropriate value specified under recommended operating conditions.

‡ All typical values are at $V_{CC} = 5 \text{ V.}, T_A = 25^\circ\text{C.}$

NOTE 2: With all outputs open, I_{CC} is measured with the Q and \bar{Q} outputs high in turn. At the time of measurement, the clock input is grounded.

switching characteristics, $V_{CC} = 5 \text{ V.}, T_A = 25^\circ\text{C}$ (see note 3)

PARAMETER	FROM (INPUT)	TO (OUTPUT)	TEST CONDITIONS		MIN	TYP	MAX	UNIT	
f_{max}			$R_L = 4 \text{ k}\Omega, C_L = 50 \text{ pF}$		2.5	3		MHz	
t_{PLH}	PRE or CLR	Q or \bar{Q}				35	75		ns
t_{PHL}	PRE or CLR (CLK high)	\bar{Q} or Q				60	150		ns
	PRE or CLR (CLK low)					200			
t_{PLH}	CLK	Q or \bar{Q}				10	35	75	ns
t_{PHL}						10	60	150	

NOTE 3: See General Information Section for load circuits and voltage waveforms.

3
TTL DEVICES

TYPES SN5472, SN54H72, SN54L72, SN7472, SN74H72

AND-GATED J-K MASTER-SLAVE FLIP-FLOPS WITH PRESET AND CLEAR

REVISED DECEMBER 1983

- Package Options Include Plastic and Ceramic DIPs
- Dependable Texas Instruments Quality and Reliability

SN5472, SN54H72, SN54L72 ... J PACKAGE
SN7472, SN74H72 ... J OR N PACKAGE

(TOP VIEW)

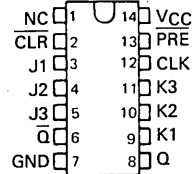

SN5472, SN54H72 ... W PACKAGE

(TOP VIEW)

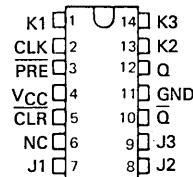

NC - No internal connection

description

These J-K flip-flops are based on the master-slave principle and each has AND gate inputs for entry into the master section which are controlled by the clock pulse. The clock pulse also regulates the state of the coupling transistors which connect the master and slave sections. The sequence of operation is as follows:

1. Isolate slave from master
2. Enter information from AND gate inputs to master
3. Disable AND gate inputs
4. Transfer information from master to slave

Logical state of J and K inputs must not be allowed to change when the clock pulse is in a high state.

The SN5472, SN54H72, and the SN54L72 are characterized for operation over the full military temperature range of -55°C to 125°C. The SN7472 and the SN74H72 are characterized for operation from 0°C to 70°C.

FUNCTION TABLE

INPUTS					OUTPUTS	
PRE	CLR	CLK	J	K	Q	Q̄
L	H	X	X	X	H	L
H	L	X	X	X	L	H
L	L	X	X	X	H [†]	H [†]
H	H	⌋	L	L	Q ₀	Q̄ ₀
H	H	⌋	H	L	H	L
H	H	⌋	L	H	L	H
H	H	⌋	H	H	TOGGLE	TOGGLE

[†] This configuration is nonstable; that is, it will not persist when either preset or clear returns to its inactive (high) level.

logic symbol

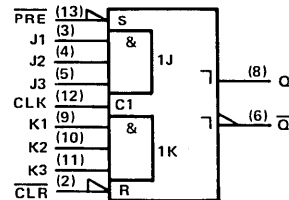

Pin numbers shown are for J and N packages.

positive logic

$$J = J1 \cdot J2 \cdot J3$$

$$K = K1 \cdot K2 \cdot K3$$

PRODUCTION DATA
This document contains information current as of publication date. Products conform to specifications per the terms of Texas Instruments standard warranty. Production processing does not necessarily include testing of all parameters.

**TEXAS
INSTRUMENTS**

POST OFFICE BOX 225012 • DALLAS, TEXAS 75265

TYPES SN5472, SN54H72, SN54L72,
 SN7472, SN74H72
 AND-GATED J-K MASTER-SLAVE FLIP-FLOPS WITH PRESET AND CLEAR

logic diagrams
 '72

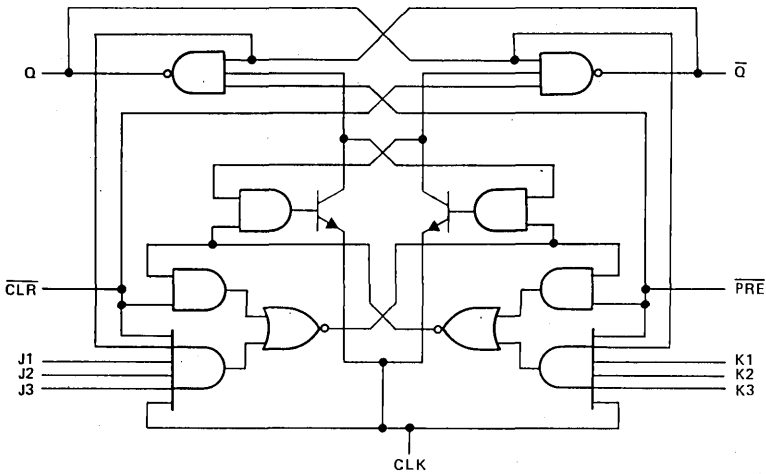

'H72

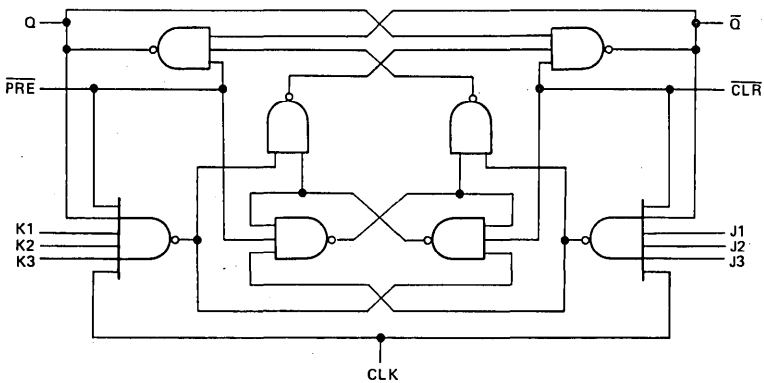

'L72

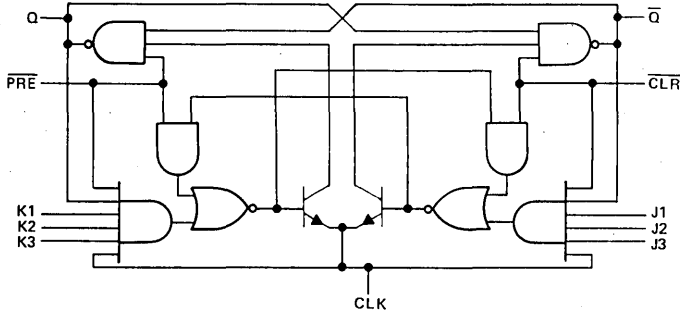

3
 TTL DEVICES

TYPES SN5472, SN7472 AND-GATED J-K MASTER-SLAVE FLIP-FLOPS WITH PRESET AND CLEAR

recommended operating conditions

	SN5472			SN7472			UNIT
	MIN	NOM	MAX	MIN	NOM	MAX	
V_{CC} Supply voltage	4.5	5	5.5	4.75	5	5.25	V
V_{IH} High-level input voltage	2			2			V
V_{IL} Low-level input voltage				0.8			V
I_{OH} High-level output current				-0.4			mA
I_{OL} Low-level output current				16			mA
t_w Pulse duration	CLK high		20	20		ns	
	CLK low		47	47			
	PRE or CLR		25	25			
t_{su} Input setup time before CLK †	0			0			ns
t_h Input hold time-data after CLK †	0			0			ns
T_A Operating free-air temperature	-55		125	0		70	°C

electrical characteristics over recommended operating free-air temperature range (unless otherwise noted)

PARAMETER	TEST CONDITIONS †	SN5472		SN7472		UNIT
		MIN	TYP‡	MAX	MIN	
V_{IK}	$V_{CC} = \text{MIN}, I_I = -12 \text{ mA}$			-1.5		V
V_{OH}	$V_{CC} = \text{MIN}, V_{IH} = 2 \text{ V}, V_{IL} = 0.8 \text{ V}, I_{OH} = -0.4 \text{ mA}$	2.4	3.4	2.4	3.4	V
V_{OL}	$V_{CC} = \text{MIN}, V_{IH} = 2 \text{ V}, V_{IL} = 0.8 \text{ V}, I_{OL} = 16 \text{ mA}$	0.2 0.4		0.2 0.4		V
I_I	$V_{CC} = \text{MAX}, V_I = 5.5 \text{ V}$	1		1		mA
I_{IH}	J or K	40		40		μA
	All other	80		80		
I_{IL}	J or K	-1.6		-1.6		mA
	All other	-3.2		-3.2		
$I_{OS}§$	$V_{CC} = \text{MAX}$	-20	-57	-18	-57	mA
I_{CC}	$V_{CC} = \text{MAX},$ See Note 2	10	20	10	20	mA

† For conditions shown as MIN or MAX, use the appropriate value specified under recommended operating conditions.

‡ All typical values are at $V_{CC} = 5 \text{ V}, T_A = 25^\circ\text{C}$.

§ Not more than one output should be shorted at a time.

NOTE 2: With all outputs open, I_{CC} is measured with the Q and \bar{Q} outputs high in turn. At the time of measurement, the clock input is grounded.

switching characteristics, $V_{CC} = 5 \text{ V}, T_A = 25^\circ\text{C}$ (see note 3)

PARAMETER	FROM (INPUT)	TO (OUTPUT)	TEST CONDITIONS	MIN	TYP	MAX	UNIT
f_{max}			$R_L = 400 \Omega, C_L = 15 \text{ pF}$	15	20		MHz
t_{PLH}	$\overline{\text{PRE}}$ or $\overline{\text{CLR}}$	Q or \bar{Q}		16	25		ns
t_{PHL}				25	40		ns
t_{PLH}	CLK	Q or \bar{Q}		16	25		ns
t_{PHL}				25	40		ns

NOTE 3: See General Information Section for load circuits and voltage waveforms.

TYPES SN54H72, SN74H72 AND-GATED J-K MASTER-SLAVE FLIP-FLOPS WITH PRESET AND CLEAR

recommended operating conditions

		SN54H72			SN74H72			UNIT
		MIN	NOM	MAX	MIN	NOM	MAX	
V_{CC}	Supply voltage	4.5	5	5.5	4.75	5	5.25	V
V_{IH}	High-level input voltage	2			2			V
V_{IL}	Low-level input voltage			0.8			0.8	V
I_{OH}	High-level output current			-0.5			-0.5	mA
I_{OL}	Low-level output current			20			20	mA
t_w	Pulse duration	CLK high		12			12	ns
		CLK low		28			28	
		CLR or PRE		16			16	
t_{su}	Setup time, before CLK †	data high or low		0		0		ns
t_h	Hold time-data after CLK †			0		0		ns
T_A	Operating free-air temperature	-55		125	0		70	°C

electrical characteristics over recommended operating free-air temperature range (unless otherwise noted)

PARAMETER	TEST CONDITIONS †	SN54H72			SN74H72			UNIT
		MIN	TYP ‡	MAX	MIN	TYP ‡	MAX	
V_{IK}	$V_{CC} = \text{MIN}$, $I_I = -8 \text{ mA}$			-1.5			-1.5	V
V_{OH}	$V_{CC} = \text{MIN}$, $V_{IH} = 2 \text{ V}$, $V_{IL} = 0.8 \text{ V}$, $I_{OH} = -0.5 \text{ mA}$	2.4	3.4		2.4	3.4		V
V_{OL}	$V_{CC} = \text{MIN}$, $V_{IH} = 2 \text{ V}$, $V_{IL} = 0.8 \text{ V}$, $I_{OL} = 20 \text{ mA}$		0.2	0.4		0.2	0.4	V
I_I	$V_{CC} = \text{MAX}$, $V_I = 5.5 \text{ V}$			1			1	mA
I_{IH}	J, K or CLK			50			50	μA
	PRE or CLR*	$V_{CC} = \text{MAX}$, $V_I = 2.4 \text{ V}$		100			100	
I_{IL}	J, K or CLR	$V_{CC} = \text{MAX}$, $V_I = 0.4 \text{ V}$		-2			-2	mA
	PRE or CLR*			-4			-4	
$I_{OS} \S$	$V_{CC} = \text{MAX}$	-40		-100	-40		-100	mA
I_{CC}	$V_{CC} = \text{MAX}$, See Note 2		16	25		16	25	mA

† For conditions shown as MIN or MAX, use the appropriate value specified under recommended operating conditions.

‡ All typical values are at $V_{CC} = 5 \text{ V}$, $T_A = 25^\circ\text{C}$.

§ Not more than one output should be shorted at a time, and the duration of the short circuit should not exceed one second.

* Clear is tested with preset high and preset is tested with clear high.

NOTE 2: With all outputs open, I_{CC} is measured with the Q and \bar{Q} outputs high in turn. At the time of measurement, the clock input is grounded.

switching characteristics, $V_{CC} = 5 \text{ V}$, $T_A = 25^\circ\text{C}$ (see note 3)

PARAMETER	FROM (INPUT)	TO (OUTPUT)	TEST CONDITIONS		MIN	TYP	MAX	UNIT
f_{max}					25	30		MHz
t_{PLH}	PRE or CLR	Q or \bar{Q}	$R_L = 280 \Omega$	$C_L = 25 \text{ pF}$	6	13		ns
t_{PHL}					12	24		ns
t_{PLH}	CLK	Q or \bar{Q}			14	21		ns
t_{PHL}					22	27		ns

NOTE 3: See General Information Section for load circuits and voltage waveforms.

3

TTL DEVICES

TYPE SN54L72

AND-GATED J-K MASTER-SLAVE FLIP-FLOPS WITH PRESET AND CLEAR

recommended operating conditions

		MIN	NOM	MAX	UNIT
V _{CC}	Supply voltage	4.5	5	5.5	V
V _{IH}	High-level input voltage	2			V
V _{IL}	Low-level input voltage			0.6	V
				0.7	
I _{OH}	High-level output current			-0.1	mA
I _{OL}	Low-level output current			2	mA
t _w	Pulse duration			200	ns
				100	
t _{su}	Setup time before CLK †	0			ns
t _h	Hold time, data after CLK †	0			ns
T _A	Operating free-air temperature	-55		125	°C

electrical characteristics over recommended operating free-air temperature range (unless otherwise noted)

PARAMETER	TEST CONDITIONS †	MIN	TYP ‡	MAX	UNIT
V _{OH}	V _{CC} = MIN, V _{IH} = 2 V, V _{IL} = MAX, I _{OH} = -0.1 mA	2.4	3.3		V
V _{OL}	V _{CC} = MIN, V _{IH} = 2 V, V _{IL} = MAX, I _{OL} = 2 mA		0.15	0.3	V
I _I	J or K	V _{CC} = MAX, V _I = 5.5 V		0.1	mA
	All other			0.2	
I _{IH}	J or K	V _{CC} = MAX, V _I = 2.4 V		10	µA
	PRE or CLR			20	
	CLK			-200	
I _{IL}	J or K	V _{CC} = MAX, V _I = 0.3 V		-0.18	mA
	All other			-0.36	
I _{OS}	V _{CC} = MAX	-3		-15	mA
I _{CC}	V _{CC} = MAX, See Note 2		0.76	1.44	mA

† For conditions shown as MIN or MAX, use the appropriate value specified under recommended operating conditions.

‡ All typical values are at V_{CC} = 5 V, T_A = 25°C.

NOTE 2: With all outputs open, I_{CC} is measured with the Q and \bar{Q} outputs high in turn. At the time of measurement, the clock input is grounded.

switching characteristics, V_{CC} = 5 V, T_A = 25°C (see note 3)

PARAMETER	FROM (INPUT)	TO (OUTPUT)	TEST CONDITIONS	MIN	TYP	MAX	UNIT	
f _{max}			R _L = 4 kΩ, C _L = 50 pF	2.5	3		MHz	
t _{PLH}	PRE or CLR	Q or \bar{Q}			35	75		ns
t _{PHL}	PRE or CLR (CLK high)	\bar{Q} or Q			60	150		ns
	PRE or CLR (CLK low)					200		
t _{PLH}	CLK	Q or \bar{Q}			10	35	75	ns
t _{PHL}					10	60	150	ns

NOTE 3: See General Information Section for load circuits and voltage waveforms.

3

TTL DEVICES

TYPES SN5473, SN54H73, SN54L73, SN54LS73A, SN7473, SN74H73, SN74LS73A DUAL J-K FLIP-FLOPS WITH CLEAR

REVISED DECEMBER 1983

- Package Options Include Plastic and Ceramic DIPs
- Dependable Texas Instruments Quality and Reliability

SN5473, SN54H73, SN54LS73A ... J OR W PACKAGE
SN54L73 ... J PACKAGE
SN7473, SN74H73 ... J OR N PACKAGE
SN74LS73A ... D, J OR N PACKAGE
(TOP VIEW)

description

The '73, 'H73, and 'L73 contain two independent J-K flip-flops with individual J-K, clock, and direct clear inputs. The '73, 'H73, and 'L73 are positive pulse-triggered flip-flops. J-K input is loaded into the master while the clock is high and transferred to the slave on the high-to-low transition. For these devices the J and K inputs must be stable while the clock is high.

The 'LS73A contain two independent negative-edge-triggered flip-flops. The J and K inputs must be stable one setup time prior to the high-to-low clock transition for predictable operation. When the clear is low, it overrides the clock and data inputs forcing the Q output low and the \bar{Q} output high.

The SN5473, SN54H73, SN54L73, and the SN54LS73A are characterized for operation over the full military temperature range of -55°C to 125°C . The SN7473, SN74H73, and the SN74LS73A are characterized for operation from 0°C to 70°C .

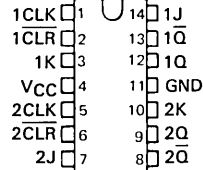

'73, 'H73, 'L73
FUNCTION TABLE

INPUTS				OUTPUTS	
CLR	CLK	J	K	Q	\bar{Q}
L	X	X	X	L	H
H	\downarrow	L	L	Q_0	\bar{Q}_0
H	\downarrow	H	L	H	L
H	\downarrow	L	H	L	H
H	\downarrow	H	H	TOGGLE	

'LS73A
FUNCTION TABLE

INPUTS				OUTPUTS	
CLR	CLK	J	K	Q	\bar{Q}
L	X	X	X	L	H
H	\downarrow	L	L	Q_0	\bar{Q}_0
H	\downarrow	H	L	H	L
H	\downarrow	L	H	L	H
H	\downarrow	H	H	TOGGLE	
H	H	X	X	Q_0	\bar{Q}_0

FOR CHIP CARRIER INFORMATION,
CONTACT THE FACTORY

3

TTL DEVICES

**TYPES SN5473, SN54H73, SN54L73, SN54LS73A,
SN7473, SN74H73, SN74LS73A
DUAL J-K FLIP-FLOPS WITH CLEAR**

logic symbols

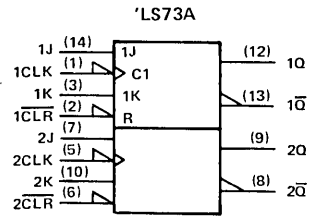
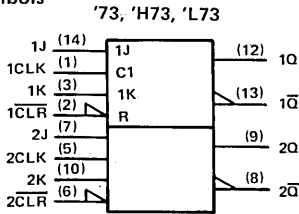

Pin numbers shown on logic notation are for D, J or N packages.

schematics of inputs and outputs

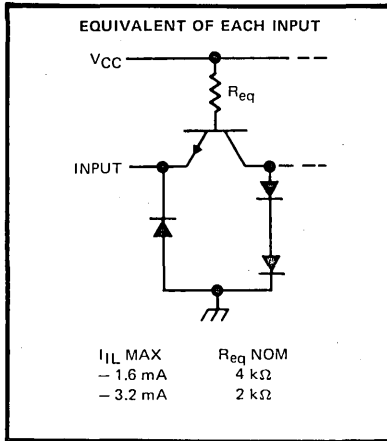

'73

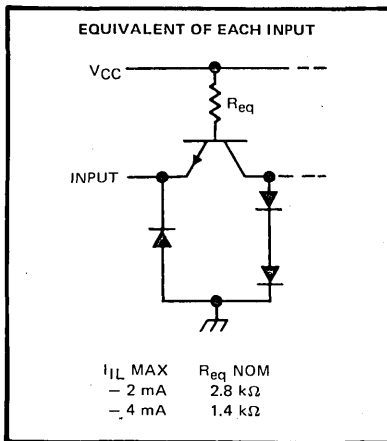
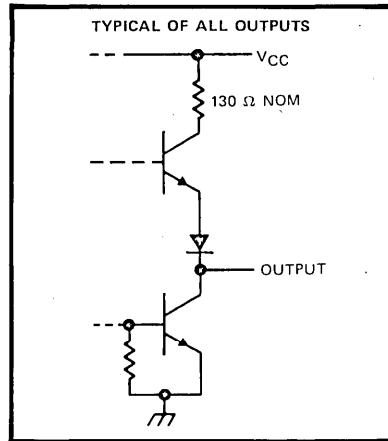

'H73

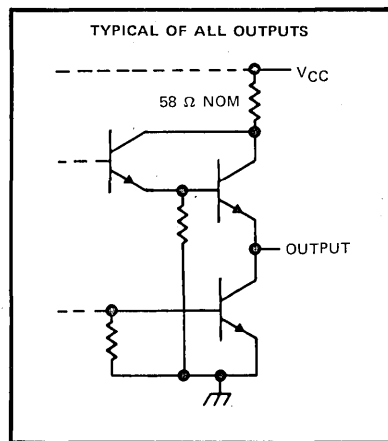

3

TTL DEVICES

schematics of inputs and outputs (continued)

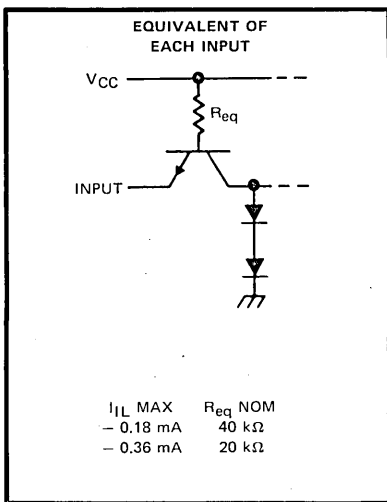

'L73

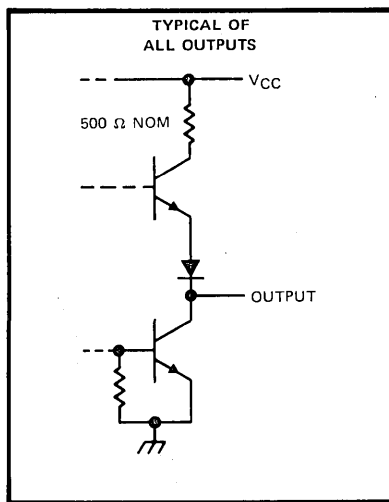

'LS73A

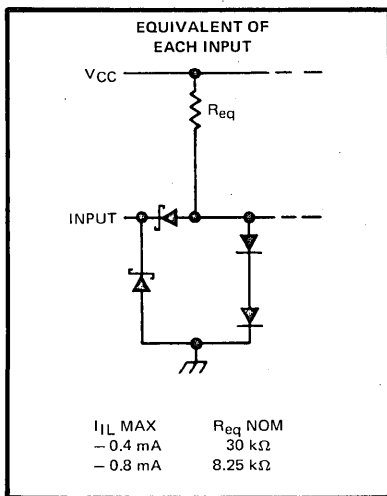

3

TTL DEVICES

TYPES SN5473, SN54H73, SN7473, SN74H73
DUAL J-K FLIP-FLOPS WITH CLEAR

logic diagrams

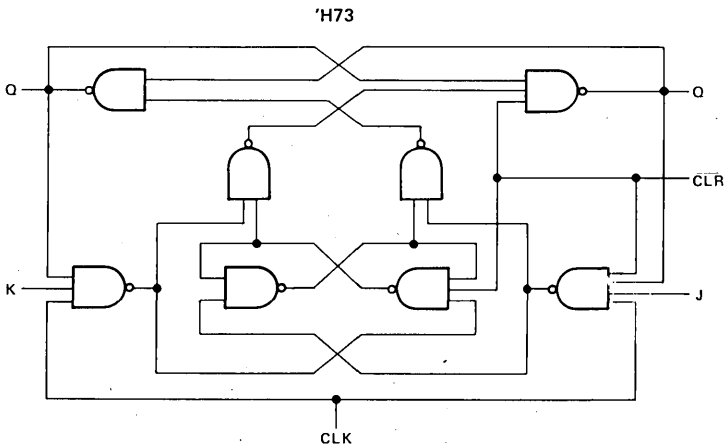
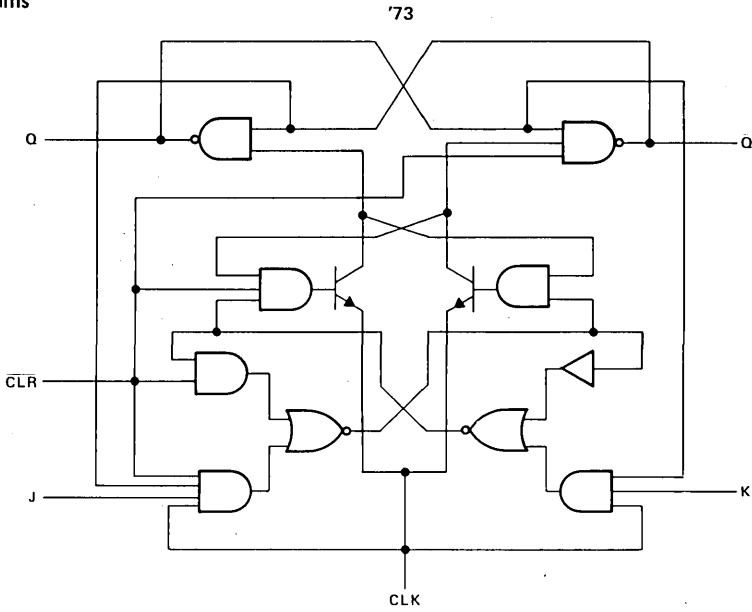

3

TTL DEVICES

TYPES SN5473, SN54H73, SN54L73, SN54LS73A,
 SN7473, SN74H73, SN74LS73A
 DUAL J-K FLIP-FLOPS WITH CLEAR

logic diagrams (continued)

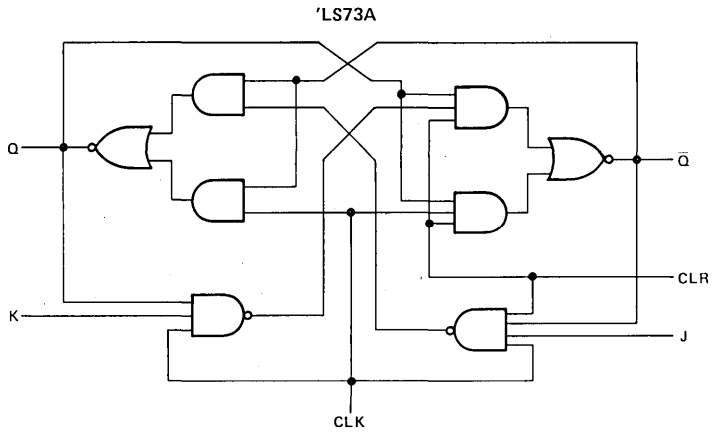
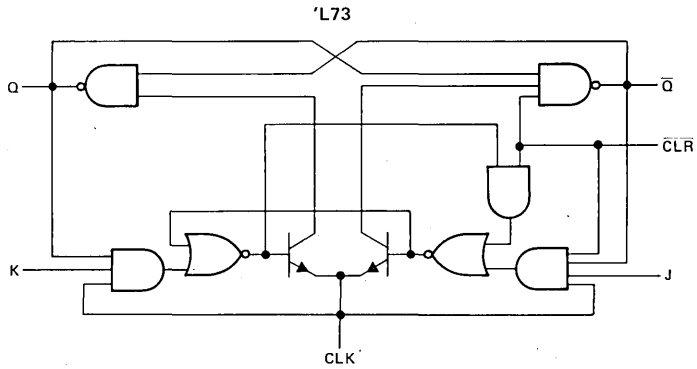

absolute maximum ratings over operating free-air temperature range (unless otherwise noted)

Supply voltage, V_{CC} (see Note 1)	7 V
Input voltage: '73, 'H73, 'L73	5.5 V
'LS73A	7 V
Operating free-air temperature range: SN54'	-55°C to 125°C
SN74'	0°C to 70°C
Storage temperature range	-65°C to 150°C

NOTE 1: Voltage values are with respect to network ground terminal.

3
TTL DEVICES

TYPES SN5473, SN7473 DUAL J-K FLIP-FLOPS WITH CLEAR

recommended operating conditions

		SN5473			SN7473			UNIT
		MIN	NOM	MAX	MIN	NOM	MAX	
V _{CC}	Supply voltage	4.5	5	5.5	4.75	5	5.25	V
V _{IH}	High-level input voltage	2			2			V
V _{IL}	Low-level input voltage				0.8			V
I _{OH}	High-level output current				-0.4			mA
I _{OL}	Low-level output current				16			mA
t _w	Pulse duration	CLK high		20	20		ns	
		CLK low		47	47			
		CLR low		25	25			
t _{su}	Input setup time before CLK †	0			0			ns
t _h	Input hold time data after CLK †	0			0			ns
T _A	Operating free-air temperature	-55		125	0		70	°C

electrical characteristics over recommended operating free-air temperature range (unless otherwise noted)

PARAMETER	TEST CONDITIONS†	SN5473			SN7473			UNIT
		MIN	TYP‡	MAX	MIN	TYP‡	MAX	
V _{IK}	V _{CC} = MIN, I _I = -12 mA	-1.5						V
V _{OH}	V _{CC} = MIN, V _{IH} = 2 V, V _{IL} = 0.8 V, I _{OH} = -0.4 mA	2.4	3.4		2.4	3.4	V	
V _{OL}	V _{CC} = MIN, V _{IH} = 2 V, V _{IL} = 0.8 V, I _{OL} = 16 mA		0.2	0.4	0.2	0.4	V	
I _I	V _{CC} = MAX, V _I = 5.5 V	1			1			mA
I _{IH}	J or K	40			40			μA
	CLR or CLK	80			80			
I _{IL}	J or K	-1.6			-1.6			mA
	CLR	-3.2			-3.2			
	CLK	-3.2			-3.2			
I _{OS} §	V _{CC} = MAX	-20	-57		-18	-57	mA	
I _{CC}	V _{CC} = MAX, See Note 2	10		20	10		20	mA

† For conditions shown as MIN or MAX, use the appropriate value specified under recommended operating conditions.

‡ All typical values are at V_{CC} = 5 V, T_A = 25°C.

§ Not more than one output should be shorted at a time.

NOTE 2: With all outputs open, I_{CC} is measured with the Q and Q outputs high in turn. At the time of measurement, the clock input is grounded.

switching characteristics, V_{CC} = 5 V, T_A = 25°C (see note 3)

PARAMETER¶	FROM (INPUT)	TO (OUTPUT)	TEST CONDITIONS		MIN	TYP	MAX	UNIT
f _{max}			R _L = 400 Ω,	C _L = 15 pF	15	20		MHz
t _{PLH}	CLR	Q			16	25	ns	
t _{PHL}		Q			25	40	ns	
t _{PLH}	CLK	Q or Q̄			16	25	ns	
t _{PHL}		Q or Q̄			25	40	ns	

¶ f_{max} = maximum clock frequency; t_{PLH} = propagation delay time, low-to-high-level output; t_{PHL} = propagation delay time, high-to-low-level output.

NOTE 3: See General Information Section for load circuits and voltage waveforms.

TTL DEVICES

TYPES SN54H73, SN74H73 DUAL J-K FLIP-FLOPS WITH CLEAR

recommended operating conditions

		SN54H73			SN74H73			UNIT
		MIN	NOM	MAX	MIN	NOM	MAX	
V _{CC}	Supply voltage	4.5	5	5.5	4.75	5	5.25	V
V _{IH}	High-level input voltage	2			2			V
V _{IL}	Low-level input voltage	0.8			0.8			V
I _{OH}	High-level output current	-0.5			-0.5			mA
I _{OL}	Low-level output current	20			20			mA
t _w	Pulse duration	CLK high	12		12		ns	
		CLK low	28		28			
		CLR low	16		16			
t _{su}	Input setup time before CLK†	High-level data	0		0		ns	
		Low-level data	0		0			
t _h	Input hold time, data after CLK‡	0			0			ns
T _A	Operating free-air temperature	-55		125		0 70		°C

electrical characteristics over recommended operating free-air temperature range (unless otherwise noted)

PARAMETER		TEST CONDITIONS†		SN54H73		SN74H73		UNIT
				MIN	TYP‡	MAX	MIN	
V _{IK}		V _{CC} = MIN, I _I = -8 mA	-1.5		-1.5		V	
V _{OH}		V _{CC} = MIN, V _{IH} = 2 V, V _{IL} = 0.8 V, I _{OH} = -0.5 mA	2.4	3.4	2.4	3.4	V	
V _{OL}		V _{CC} = MIN, V _{IH} = 2 V, V _{IL} = 0.8 V, I _{OL} = 20 mA	0.2 0.4		0.2 0.4		V	
I _I		V _{CC} = MAX, V _I = 5.5 V	1		1		mA	
I _{IH}	J, K, or CLK	V _{CC} = MAX, V _I = 2.4 V	50		50		μA	
	CLR		100		100			
I _{IL}	J, K, or CLK	V _{CC} = MAX, V _I = 0.4 V	-2		-2		mA	
	CLR		-4		-4			
I _{OS} §		V _{CC} = MAX	-40	-100	-40	-100	mA	
I _{CC}		V _{CC} = MAX, See Note 2	16	25	16	25	mA	

† For conditions shown as MIN or MAX, use the appropriate value specified under recommended operating conditions.

‡ All typical values are at V_{CC} = 5 V, T_A = 25°C.

§ Not more than one output should be shorted at a time, and the duration of the short circuit should not exceed one second.

NOTE 2: With all outputs open, I_{CC} is measured with the Q and \bar{Q} outputs high in turn. At the time of measurement, the clock input is grounded.

switching characteristics, V_{CC} = 5 V, T_A = 25°C (see note 3)

PARAMETER	FROM (INPUT)	TO (OUTPUT)	TEST CONDITIONS		MIN	TYP	MAX	UNIT
f _{max}			R _L = 280 Ω, C _L = 25 pF		25	30		MHz
t _{PLH}	\bar{CLR}	\bar{Q}			6	13	ns	
t _{PHL}		Q			12	24	ns	
t _{PLH}	CLK	Q or \bar{Q}			14	21	ns	
t _{PHL}					22	27	ns	

NOTE 3: See General Information Section for load circuits and voltage waveforms.



TTL DEVICES

TYPE SN54L73 DUAL J-K FLIP-FLOPS WITH CLEAR

recommended operating conditions

		MIN	NOM	MAX	UNIT
V _{CC}	Supply voltage	4.5	5	5.5	V
V _{IH}	High-level input voltage	2			V
V _{IL}	Low-level input voltage	Clock input		0.6	V
		All other inputs		0.7	
I _{OH}	High-level output current	-0.1			mA
I _{OL}	Low-level output current	2			mA
t _w	Pulse duration	CLK high or low		200	ns
		CLR low		100	
t _{su}	Setup time before CLK †	0			ns
t _h	Hold time-data after CLK †	0			ns
T _A	Operating free-air temperature	-55		125	°C

electrical characteristics over recommended operating free-air temperature range (unless otherwise noted)

PARAMETER	TEST CONDITIONS†	MIN	TYP ‡	MAX	UNIT		
V _{OH}	V _{CC} = MIN, V _{IH} = 2 V, V _{IL} = MAX, I _{OH} = -0.1 mA	2.4	3.3		V		
V _{OL}	V _{CC} = MIN, V _{IH} = 2 V, V _{IL} = MAX, I _{OL} = 2 mA		0.15	0.3	V		
I _I	J or K	V _{CC} = MAX, V _I = 5.5 V			0.1	mA	
	CLR or CLK						0.2
I _{IH}	J or K	V _{CC} = MAX, V _I = 2.4 V			10	μA	
	CLR						20
	CLK						-200
I _{IL}	J or K	V _{CC} = MAX, V _I = 0.3 V			-0.18	mA	
	CLR or CLK						-0.36
I _{OS}	V _{CC} = MAX	-3		-15	mA		
I _{CC}	V _{CC} = MAX, See Note 2		0.76	1.44	mA		

† For conditions shown as MIN or MAX, use the appropriate value specified under recommended operating conditions.

‡ All typical values are at V_{CC} = 5 V, T_A = 25°C.

NOTE 2: With all outputs open, I_{CC} is measured with the Q and \bar{Q} outputs high in turn. At the time of measurement, the clock input is grounded.

switching characteristics, V_{CC} = 5 V, T_A = 25°C (see note 3)

PARAMETER	FROM (INPUT)	TO (OUTPUT)	TEST CONDITIONS	MIN	TYP	MAX	UNIT
f _{max}			R _L = 4 kΩ, C _L = 50 pF	2.5	3		MHz
t _{PLH}	CLR	Q or \bar{Q}		35	75		ns
t _{PHL}	CLR (CLK high)	\bar{Q} or Q		60	150		ns
	CLR (CLK low)			200			
t _{PLH}	CLK	Q or \bar{Q}		10	35	75	ns
t _{PHL}				10	60	150	ns

NOTE 3: See General Information Section for load circuits and voltage waveforms.

3

TTL DEVICES

TYPES SN54LS73A, SN74LS73A DUAL J-K FLIP-FLOPS WITH CLEAR

recommended operating conditions

		SN54LS73A			SN74LS73A			UNIT
		MIN	NOM	MAX	MIN	NOM	MAX	
V _{CC}	Supply voltage	4.5	5	5.5	4.75	5	5.25	V
V _{IH}	High-level input voltage	2			2			V
V _{IL}	Low-level input voltage			0.7			0.8	V
I _{OH}	High-level output current			-0.4			-0.4	mA
I _{OL}	Low-level output current			4			8	mA
f _{clock}	Clock frequency	0		30	0		30	MHz
t _w	Pulse duration	CLK high		20			20	ns
		CLR low		25			20	
t _{su}	Set up time-before CLK ↓	data high or low		20			20	ns
		CLR inactive		20			20	
t _h	Hold time-data after CLK ↓			0			0	ns
T _A	Operating free-air temperature	-55		125	0		70	°C

electrical characteristics over recommended operating free-air temperature range (unless otherwise noted)

PARAMETER		TEST CONDITIONS†	SN54LS73A		SN74LS73A		UNIT		
			MIN	TYP‡	MAX	MIN		TYP‡	MAX
V _{IK}		V _{CC} = MIN, I _I = -18 mA			-1.5		-1.5	V	
V _{OH}		V _{CC} = MIN, V _{IH} = 2 V, V _{IL} = MAX, I _{OH} = -0.4 mA	2.5	3.4		2.7	3.4	V	
V _{OL}		V _{CC} = MIN, V _{IL} = MAX, V _{IH} = 2 V, I _{OL} = 4 mA		0.25	0.4		0.25	0.4	V
		V _{CC} = MIN, V _{IL} = MAX, V _{IH} = 2 V, I _{OL} = 8 mA					0.35	0.5	
I _I	J or K	V _{CC} = MAX, V _I = 7 V		0.1			0.1	mA	
	CLR			0.3			0.3		
	CLK			0.4			0.4		
I _{IH}	J or K	V _{CC} = MAX, V _I = 2.7 V		20			20	μA	
	CLR			60			60		
	CLK			80			80		
I _{IL}	J or K	V _{CC} = MAX, V _I = 0.4 V		-0.4			-0.4	mA	
	CLR or CLK			-0.8			-0.8		
I _{OS} §		V _{CC} = MAX, See Note 4	-20		-100	-20		-100	mA
I _{CC}		V _{CC} = MAX, See Note 2		4	6		4	6	mA

† For conditions shown as MIN or MAX, use the appropriate value specified under recommended operating conditions.

‡ All typical values are at V_{CC} = 5 V, T_A = 25°C.

§ Not more than one output should be shorted at a time, and the duration of the short circuit should not exceed one second.

NOTE 2: With all outputs open, I_{CC} is measured with the Q and Q̄ outputs high in turn. At the time of measurement, the clock input is grounded.

NOTE 4: For certain devices where state commutation can be caused by shorting an output to ground, an equivalent test may be performed with V_O = 2.25 V and 2.125 V for the 54 family and the 74 family, respectively, with the minimum and maximum limits reduced to one half of their stated values.

switching characteristics, V_{CC} = 5 V, T_A = 25°C (see note 3)

PARAMETER	FROM (INPUT)	TO (OUTPUT)	TEST CONDITIONS		MIN	TYP	MAX	UNIT	
f _{max}			R _L = 2 kΩ, C _L = 15 pF		30	45		MHz	
t _{PLH}	CLR or CLK	Q or Q̄				15	20		ns
t _{PHL}						15	20		ns

NOTE 3: See General Information Section for load circuits and voltage waveforms.

3
TTL DEVICES



TTL DEVICES

TYPES SN5474, SN54H74, SN54L74, SN54LS74A, SN54S74, SN7474, SN74H74, SN74LS74A, SN74S74

DUAL D-TYPE POSITIVE-EDGE-TRIGGERED FLIP-FLOPS WITH PRESET AND CLEAR

REVISED DECEMBER 1983

- Package Options Include Both Plastic and Ceramic Chip Carriers in Addition to Plastic and Ceramic DIPs
- Dependable Texas Instruments Quality and Reliability

description

These devices contain two independent D-type positive-edge-triggered flip-flops. A low level at the preset or clear inputs sets or resets the outputs regardless of the levels of the other inputs. When preset and clear are inactive (high), data at the D input meeting the setup time requirements are transferred to the outputs on the positive-going edge of the clock pulse. Clock triggering occurs at a voltage level and is not directly related to the rise time of the clock pulse. Following the hold time interval, data at the D input may be changed without affecting the levels at the outputs.

The SN54' family is characterized for operation over the full military temperature range of -55°C to 125°C . The SN74' family is characterized for operation from 0°C to 70°C .

FUNCTION TABLE

INPUTS				OUTPUTS	
PRE	CLR	CLK	D	Q	\bar{Q}
L	H	X	X	H	L
H	L	X	X	L	H
L	L	X	X	H \dagger	H \dagger
H	H	\uparrow	H	H	L
H	H	\uparrow	L	L	H
H	H	L	X	Q_0	\bar{Q}_0

\dagger The output levels in this configuration are not guaranteed to meet the minimum levels in V_{OH} if the lows at preset and clear are near V_{IL} maximum. Furthermore, this configuration is nonstable; that is, it will not persist when either preset or clear returns to its inactive (high) level.

logic symbol

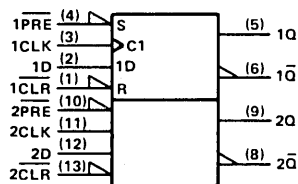

Pin numbers shown on logic notation are for D, J or N packages.

SN5474, SN54H74, SN54L74 ... J PACKAGE
 SN54LS74A, SN54S74 ... J OR W PACKAGE
 SN7474, SN74H74 ... J OR N PACKAGE
 SN74LS74A, SN74S74 ... D, J OR N PACKAGE

(TOP VIEW)

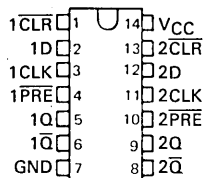

SN5474, SN54H74 ... W PACKAGE

(TOP VIEW)

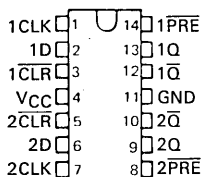

SN54LS74A, SN54S74 ... FK PACKAGE
 SN74LS74A, SN74S74 ... FN PACKAGE

(TOP VIEW)

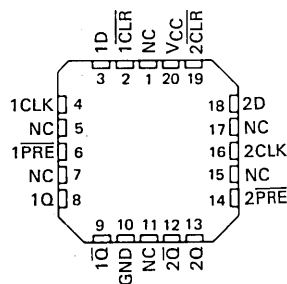

NC - No internal connection

logic diagram

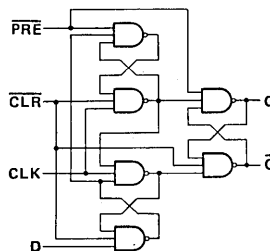

PRODUCTION DATA
 This document contains information current as of publication date. Products conform to specifications per the terms of Texas Instruments standard warranty. Production processing does not necessarily include testing of all parameters.

TEXAS
 INSTRUMENTS

POST OFFICE BOX 225012 • DALLAS, TEXAS 75265

TTL DEVICES

TYPES SN5474, SN54H74, SN7474, SN74H74
 DUAL D-TYPE POSITIVE-EDGE-TRIGGERED FLIP-FLOPS WITH PRESET AND CLEAR

schematics of inputs and outputs

74

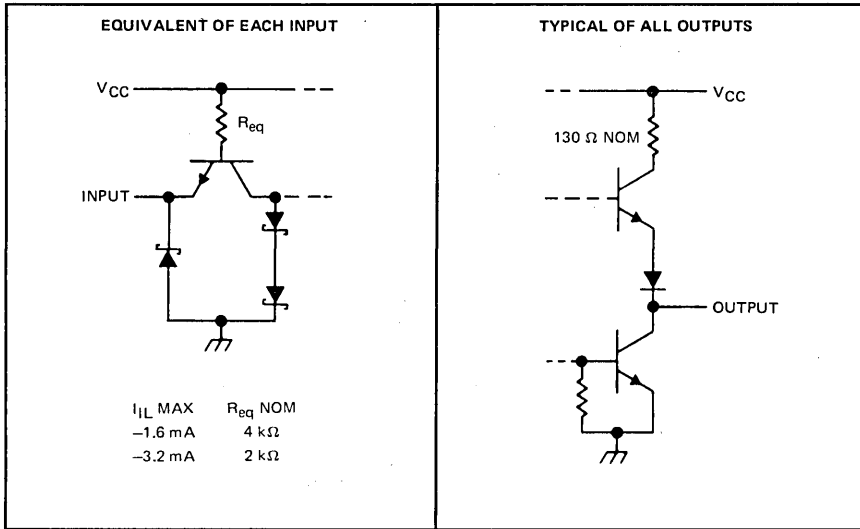

H74

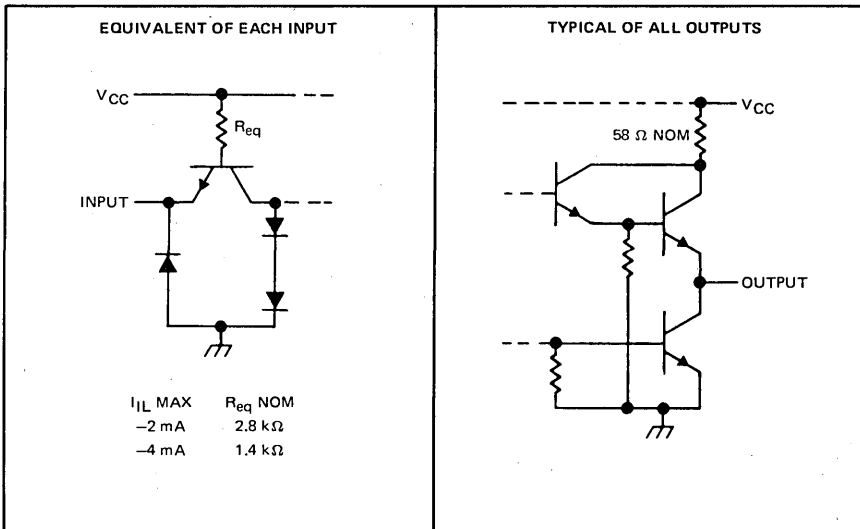

3

TTL DEVICES

TYPES SN54L74, SN54S74, SN74S74
 DUAL D-TYPE POSITIVE-EDGE-TRIGGERED FLIP-FLOPS WITH PRESET AND CLEAR

schematics of inputs and outputs (continued)

'L74

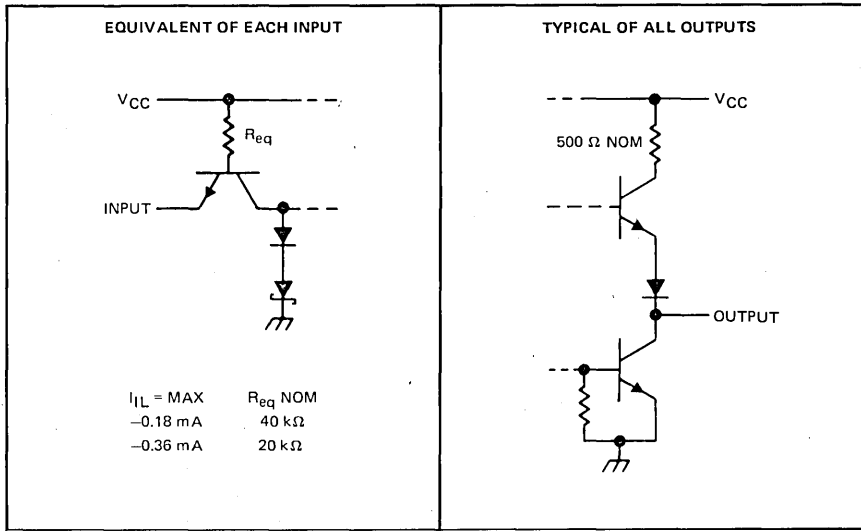

'S74

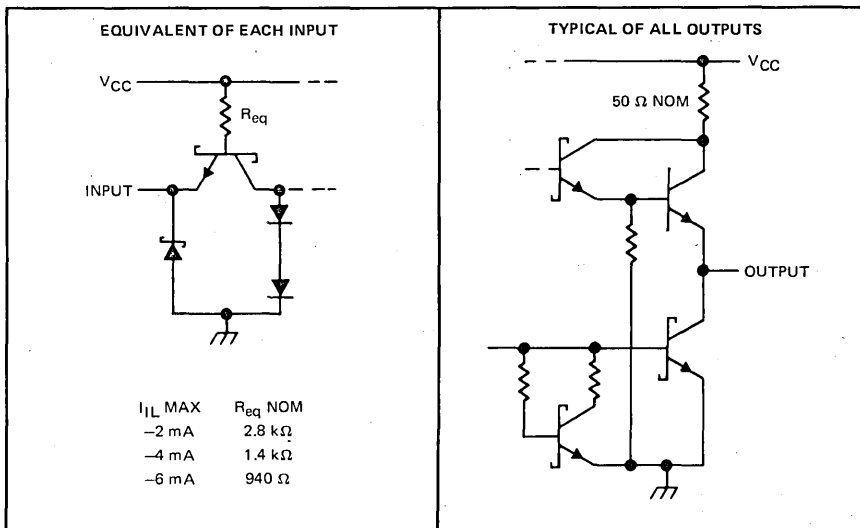

3

TTL DEVICES

TYPES SN5474, SN54H74, SN54L74, SN54LS74A, SN54S74,
 SN7474, SN74H74, SN74LS74A, SN74S74
 DUAL D-TYPE POSITIVE-EDGE-TRIGGERED FLIP-FLOPS WITH PRESET AND CLEAR

schematic

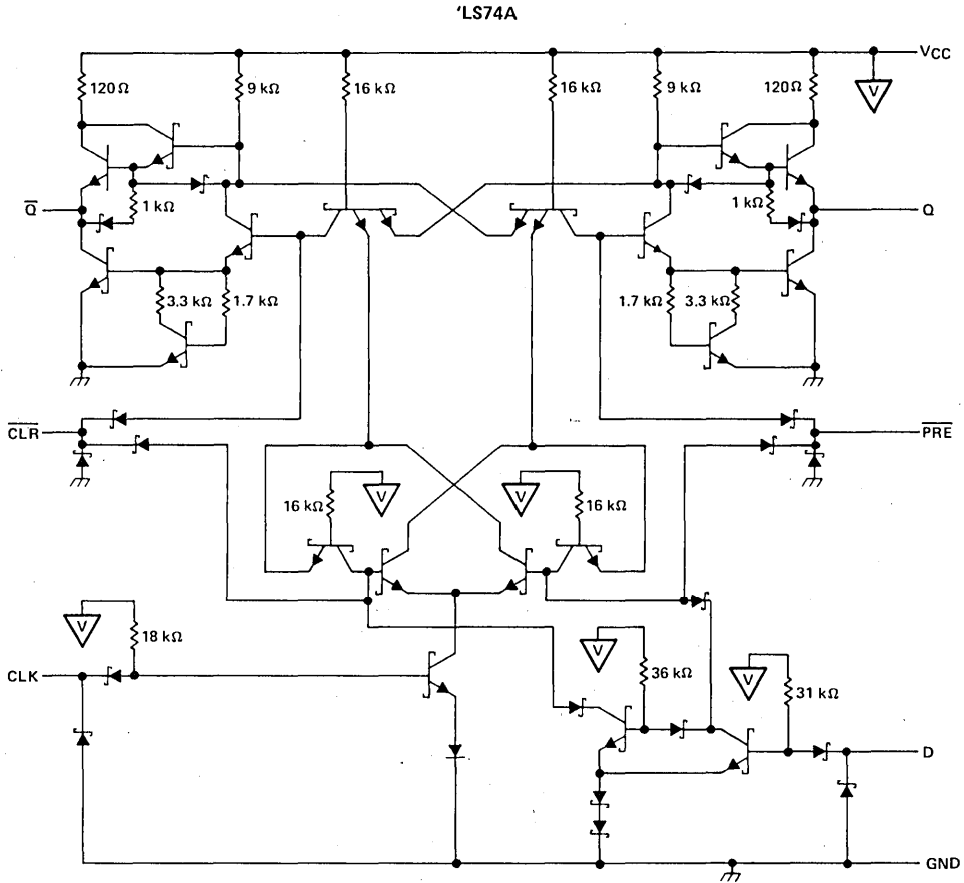

absolute maximum ratings over operating free-air temperature (unless otherwise noted)

Supply voltage, V_{CC} (see Note 1)	7 V
Input voltage: '74, 'H74, 'L74, 'S74	5.5 V
'LS74A	7 V
Operating free-air temperature range: SN54'	-55°C to 125°C
SN74'	0°C to 70°C
Storage temperature range	-65°C to 150°C

NOTE 1: Voltage values are with respect to network ground terminal.

TYPES SN5474, SN7474 DUAL D-TYPE POSITIVE-EDGE-TRIGGERED FLIP-FLOPS WITH PRESET AND CLEAR

recommended operating conditions

		SN5474			SN7474			UNIT
		MIN	NOM	MAX	MIN	NOM	MAX	
V _{CC}	Supply voltage	4.5	5	5.5	4.75	5	5.25	V
V _{IH}	High-level input voltage	2			2			V
V _{IL}	Low-level input voltage				0.8			V
I _{OH}	High-level output current				-0.4			mA
I _{OL}	Low-level output current				16			mA
t _w	Pulse duration	CLK high		30	30		ns	
		CLK low		37	37			
		PRE or CLR low		30	30			
t _{su}	Input setup time before CLK †	20			20			ns
t _h	Input hold time-data after CLK †	5			5			ns
T _A	Operating free-air temperature	-55		125	0		70	°C

electrical characteristics over recommended operating free-air temperature range (unless otherwise noted)

PARAMETER	TEST CONDITIONS†	SN5474			SN7474			UNIT
		MIN	TYP‡	MAX	MIN	TYP‡	MAX	
V _{IK}	V _{CC} = MIN, I _I = -12 mA	-1.5			-1.5			V
V _{OH}	V _{CC} = MIN, I _{OH} = -0.4 mA, V _{IH} = 2 V, V _{IL} = 0.8 V,	2.4	3.4		2.4	3.4		V
V _{OL}	V _{CC} = MIN, I _{OL} = 16 mA, V _{IH} = 2 V, V _{IL} = 0.8 V,	0.2	0.4		0.2	0.4		V
I _I	V _{CC} = MAX, V _I = 5.5 V	1			1			mA
I _{IH}	D	40			40			mA
	CLR	120			120			
	All Other	80			80			
I _{IL}	D	-1.6			-1.6			mA
	PRE*	-1.6			-1.6			
	CLR*	-3.2			-3.2			
	CLK	-3.2			-3.2			
I _{OS} §	V _{CC} = MAX	-20	-57		-18	-57		mA
I _{CC}	V _{CC} = MAX, See Note 2	8.5	15		8.5	15		mA

† For conditions shown as MIN or MAX, use the appropriate value specified under recommended operating conditions.

‡ All typical values are at V_{CC} = 5 V, T_A = 25°C.

* Clear is tested with preset high and preset is tested with clear high.

§ Not more than one output should be shorted at a time.

NOTE 2: With all outputs open, I_{CC} is measured with the Q and \bar{Q} outputs high in turn. At the time of measurement, the clock input is grounded.

switching characteristics, V_{CC} = 5 V, T_A = 25°C (see note 3)

PARAMETER	FROM (INPUT)	TO (OUTPUT)	TEST CONDITIONS	MIN	TYP	MAX	UNIT
f _{max}				15	25		MHz
t _{PLH}	$\overline{\text{PRE}}$ or $\overline{\text{CLR}}$	Q or \bar{Q}	R _L = 400 Ω, C _L = 15 pF			25	ns
t _{PHL}						40	ns
t _{PLH}	CLK	Q or \bar{Q}			14	25	ns
t _{PHL}					20	40	ns

NOTE 3: See General Information Section for load circuits and voltage waveforms.

TYPES SN54H74, SN74H74

DUAL D-TYPE POSITIVE-EDGE-TRIGGERED FLIP-FLOPS WITH PRESET AND CLEAR

recommended operating conditions

		SN54H74			SN74H74			UNIT
		MIN	NOM	MAX	MIN	NOM	MAX	
V _{CC}	Supply voltage	4.5	5	5.5	4.75	5	5.25	V
V _{IH}	High-level input voltage	2			2			V
V _{IL}	Low-level input voltage				0.8			V
I _{OH}	High-level output current				-1			mA
I _{OL}	Low-level output current				20			mA
t _w	Pulse duration	CLK high		15	15		ns	
		CLK low		13.5	13.5			
		CLR or PRE low		25	25			
t _{su}	Setup time-before CLK ↑	High-level data		10	10		ns	
		Low-level data		15	15			
t _h	Hold time - data after CLK ↑	5			5			ns
T _A	Operating free-air temperature	-55			125	0		70 °C

electrical characteristics over recommended operating free-air temperature range (unless otherwise noted)

PARAMETER	TEST CONDITIONS†	SN54H74		SN74H74		UNIT	
		MIN	TYP‡	MAX	MIN		TYP‡
V _{IK}	V _{CC} = MIN, I _I = -8 mA			-1.5		V	
V _{OH}	V _{CC} = MIN, V _{IH} = 2 V, V _{IL} = 0.8 V, I _{OH} = -1 mA	2.4	3.4	2.4	3.4	V	
V _{OL}	V _{CC} = MIN, V _{IH} = 2 V, V _{IL} = 0.8 V, I _{OL} = 20 mA	0.2		0.4	0.2	0.4	V
I _I	V _{CC} = MAX, V _I = 5.5 V			1		1	mA
I _{IH}	D			50		50	μA
	CLR	V _{CC} = MAX, V _I = 2.4 V		150		150	
	PRE or CLK			100		100	
I _{IL}	D			-2		-2	mA
	CLR*	V _{CC} = MAX, V _I = 0.4 V		-4		-4	
	PRE*			-2		-2	
	CLK			-4		-4	
				-4		-4	
I _{OS} §	V _{CC} = MAX	-40	-100	-40	-100	mA	
I _{CC}	V _{CC} = MAX, See Note 2	15		21	15	25	mA

† For conditions shown as MIN or MAX, use the appropriate value specified under recommended operating conditions.

‡ All typical values are at V_{CC} = 5 V, T_A = 25°C.

§ Not more than one output should be shorted at a time, and the duration of the short circuit should not exceed one second.

* Clear is tested with preset high and preset is tested with clear high.

NOTE 2: With all outputs open, I_{CC} is measured with the Q and Q̄ outputs high in turn. At the time of measurement, the clock input is grounded.

switching characteristics, V_{CC} = 5 V, T_A = 25°C (see note 3)

PARAMETER	FROM (INPUT)	TO (OUTPUT)	TEST CONDITIONS		MIN	TYP	MAX	UNIT	
f _{max}			R _L = 280 Ω, C _L = 25 pF		35	43		MHz	
t _{PLH}	PRE or CLR	Q or Q̄						20	ns
t _{PHL}								30	ns
t _{PLH}	CLK	Q or Q̄					8.5	15	ns
t _{PHL}							13	20	ns

NOTE 3: See General Information Section for load circuits and voltage waveforms.

3 TTL DEVICES

TYPE SN54L74 DUAL D-TYPE POSITIVE-EDGE-TRIGGERED FLIP-FLOPS WITH PRESET AND CLEAR

recommended operating conditions

		MIN	NOM	MAX	UNIT
V _{CC}	Supply voltage	4.5	5	5.5	V
V _{IH}	High-level input voltage	2			V
V _{IL}	Low-level input voltage			0.7	V
I _{OH}	High-level output current			-0.1	mA
I _{OL}	Low-level output current			2	mA
t _w	Pulse duration	CLK high or low	200		ns
		CLR or PRE low	100		
t _{su}	Setup time before CLK †		50		ns
t _h	Hold time data after CLK †		15		ns
T _A	Operating free-air temperature	-55		125	°C

electrical characteristics over recommended operating free-air temperature range (unless otherwise noted)

PARAMETER		TEST CONDITIONS†			MIN	TYP‡	MAX	UNIT
V _{OH}		V _{CC} = MIN, V _{IH} = 2 V, V _{IL} = 0.7 V, I _{OH} = -0.1 mA	2.4	3.3			V	
V _{OL}		V _{CC} = MIN, V _{IH} = 2 V, V _{IL} = 0.7 V, I _{OL} = 2 mA		0.15	0.3		V	
I _I	D	V _{CC} = MAX, V _I = 5.5 V			0.1		mA	
	CLR				0.3			
	PRE or CLK				0.2			
I _{IH}	D	V _{CC} = MAX, V _I = 2.4 V			10		μA	
	CLR				30			
	PRE or CLK				20			
I _{IL}	D or PRE	V _{CC} = MAX, V _I = 0.3 V			-0.18		μA	
	CLR or CLK				-0.36			
I _{OS}		V _{CC} = MAX	-3		-15		mA	
I _{CC}		V _{CC} = MAX, See Note 2		0.8	1.5		mA	

† For conditions shown as MIN or MAX, use the appropriate value specified under recommended operating conditions.

‡ All typical values are at V_{CC} = 5 V, T_A = 25°C.

NOTE 2: With all outputs open, I_{CC} is measured with the Q and \bar{Q} outputs high in turn. At the time of measurement, the clock input is grounded.

switching characteristics, V_{CC} = 5 V, T_A = 25°C (see note 3)

PARAMETER	FROM (INPUT)	TO (OUTPUT)	TEST CONDITIONS		MIN	TYP	MAX	UNIT
f _{max}			R _L = 4 kΩ, C _L = 50 pF		2.5	3		MHz
t _{PLH}	PRE or CLR	Q or \bar{Q}			50	75		ns
t _{PHL}	PRE or CLR (CLK high)	\bar{Q} or Q			80	150		ns
	PRE or CLR (CLK low)				80	150		
t _{PLH}	Clock	Q or \bar{Q}			15	65	100	ns
t _{PHL}					15	65	150	ns

NOTE 3: See General Information Section for load circuits and voltage waveforms.

3

TTL DEVICES

TYPES SN54LS74A, SN74LS74A

DUAL D-TYPE POSITIVE-EDGE-TRIGGERED FLIP-FLOPS WITH PRESET AND CLEAR

recommended operating conditions

		SN54LS74A			SN74LS74A			UNIT
		MIN	NOM	MAX	MIN	NOM	MAX	
V _{CC}	Supply voltage	4.5	5	5.5	4.75	5	5.25	V
V _{IH}	High-level input voltage	2			2			V
V _{IL}	Low-level input voltage			0.7			0.8	V
I _{OH}	High-level output current			-0.4			-0.4	mA
I _{OL}	Low-level output current			4			8	mA
f _{clock}	Clock frequency		0	25		0	25	MHz
t _w	Pulse duration	CLK high		25	25			ns
		PRE or CLR low		25	25			
t _{su}	Setup time-before CLK ↑	High-level data		20	20			ns
		Low-level data		20	20			
t _h	Hold time-data after CLK ↑	5			5			ns
T _A	Operating free-air temperature	-55		125	0		70	°C

electrical characteristics over recommended operating free-air temperature range (unless otherwise noted)

PARAMETER	TEST CONDITIONS†	SN54LS74A		SN74LS74A		UNIT
		MIN	TYP‡	MAX	MIN	
V _{IK}	V _{CC} = MIN, I _I = -18 mA	-1.5		-1.5		V
V _{OH}	V _{CC} = MIN, V _{IH} = 2 V, V _{IL} = MAX, I _{OH} = -0.4 mA	2.5	3.4	2.7	3.4	V
V _{OL}	V _{CC} = MIN, V _{IL} = MAX, V _{IH} = 2 V, I _{OL} = 4 mA	0.25	0.4	0.25	0.4	V
	V _{CC} = MIN, V _{IL} = MAX, V _{IH} = 2 V, I _{OL} = 8 mA			0.35	0.5	
I _I	V _{CC} = MAX, V _I = 7 V	D or CLK		0.1		mA
		CLR or PRE		0.2		
I _{IH}	V _{CC} = MAX, V _I = 2.7 V	D or CLK		20		μA
		CLR or PRE		40		
I _{IL}	V _{CC} = MAX, V _I = 0.4 V	D or CLK		-0.4		mA
		CLR or PRE		-0.8		
I _{OS} §	V _{CC} = MAX, See Note 4	-20	-100	-20	-100	mA
I _{CC}	V _{CC} = MAX, See Note 2	4 8		4 8		mA

† For conditions shown as MIN or MAX, use the appropriate value specified under recommended operating conditions.

‡ All typical values are at V_{CC} = 5 V, T_A = 25°C.

§ Not more than one output should be shorted at a time, and the duration of the short circuit should not exceed one second.

NOTE 2: With all outputs open, I_{CC} is measured with the Q and \bar{Q} outputs high in turn. At the time of measurement, the clock input is grounded.

NOTE 4: For certain devices where state commutation can be caused by shorting an output to ground, an equivalent test may be performed with V_O = 2.25 V and 2.125 V for the 54 family and the 74 family, respectively, with the minimum and maximum limits reduced to one half of their stated values.

switching characteristics, V_{CC} = 5 V, T_A = 25°C (see note 3)

PARAMETER	FROM (INPUT)	TO (OUTPUT)	TEST CONDITIONS	MIN	TYP	MAX	UNIT
f _{max}				25	33		MHz
t _{PLH}	$\overline{\text{CLR}}$, $\overline{\text{PRE}}$ or CLK	Q or \bar{Q}	R _L = 2 kΩ, C _L = 15 pF	13	25		ns
t _{PHL}				25	40		ns

NOTE 3: See General Information Section for load circuits and voltage waveforms.

TYPES SN54S74, SN74S74 DUAL D-TYPE POSITIVE-EDGE-TRIGGERED FLIP-FLOPS WITH PRESET AND CLEAR

recommended operating conditions

		SN54S74			SN74S74			UNIT
		MIN	NOM	MAX	MIN	NOM	MAX	
V _{CC}	Supply voltage	4.5	5	5.5	4.75	5	5.25	V
V _{IH}	High-level input voltage	2			2			V
V _{IL}	Low-level input voltage	0.8			0.8			V
I _{OH}	High-level output current	-1			-1			mA
I _{OL}	Low-level output current	20			20			mA
t _w	Pulse duration	CLK high		6	6		ns	
		CLK low		7.3	7.3			
		CLR or PRE low		7	7			
t _{su}	Setup time, before CLK †	High-level data		3	3		ns	
		Low-level data		3	3			
t _h	Input hold time - data after CLK †	2			2			ns
T _A	Operating free-air temperature	-55		125	0		70	°C

electrical characteristics over recommended operating free-air temperature range (unless otherwise noted)

PARAMETER		TEST CONDITIONS†		SN54S74		SN74S74		UNIT
				MIN	TYP‡	MAX	MIN	
V _{IK}		V _{CC} = MIN, I _I = -18 mA,		-1.2		-1.2		V
V _{OH}		V _{CC} = MIN, V _{IH} = 2 V, V _{IL} = 0.8 V, I _{OH} = -1 mA		2.5	3.4	2.7	3.4	V
V _{OL}		V _{CC} = MIN, V _{IH} = 2 V, V _{IL} = 0.8 V, I _{OL} = 20 mA		0.5		0.5		V
I _I		V _{CC} = MAX, V _I = 5.5 V		1		1		mA
I _{IH}	D	V _{CC} = MAX, V _I = 2.7 V		50		50		mA
	CLR			150		150		
	PRE or CLK			100		100		
I _{IL}	D	V _{CC} = MAX, V _I = 0.5 V		-2		-2		mA
	CLR*			-6		-6		
	PRE*			-4		-4		
	CLK			-4		-4		
I _{OS} §		V _{CC} = MAX		-40	-100	-40	-100	mA
I _{CC}		V _{CC} = MAX, See Note 2		15	25	15	25	mA

† For conditions shown as MIN or MAX, use the appropriate value specified under recommended operating conditions.

‡ All typical values are at V_{CC} = 5 V, T_A = 25°C.

§ Not more than one output should be shorted at a time, and the duration of the short circuit should not exceed one second.

* Clear is tested with preset high and preset is tested with clear high.

NOTE 2: All outputs open, I_{CC} is measured with the Q and \bar{Q} outputs high in turn. At the time of measurement, the clock input is grounded.

switching characteristics, V_{CC} = 5 V, T_A = 25°C (see note 3)

PARAMETER	FROM (INPUT)	TO (OUTPUT)	TEST CONDITIONS		MIN	TYP	MAX	UNIT	
f _{max}					75	110		MHz	
t _{PLH}	PRE or CLR	Q or \bar{Q}	R _L = 280 Ω, C _L = 15 pF		4	6		ns	
t _{PHL}	PRE or CLR (CLK high)	\bar{Q} or Q			9	13.5			ns
	PRE or CLR (CLK low)				5	8			
t _{PLH}	CLK	Q or \bar{Q}			6	9			ns
t _{PHL}			6	9			ns		

NOTE 3: See General Information Section for load circuits and voltage waveforms.

3

TTL DEVICES

3

TTL DEVICES

TYPES SN5475, SN5477, SN54L75, SN54L77, SN54LS75, SN54LS77, SN7475, SN74LS75

4-BIT BISTABLE LATCHES

MARCH 1974—REVISED DECEMBER 1983

logic

FUNCTION TABLE
(each latch)

INPUTS		OUTPUTS	
D	C	Q	\bar{Q}
L	H	L	H
H	H	H	L
X	L	Q_0	\bar{Q}_0

H = high level, L = low level, X = irrelevant
 Q_0 = the level of Q before the high-to-low transition of G

description

These latches are ideally suited for use as temporary storage for binary information between processing units and input/output or indicator units. Information present at a data (D) input is transferred to the Q output when the enable (C) is high and the Q output will follow the data input as long as the enable remains high. When the enable goes low, the information (that was present at the data input at the time the transition occurred) is retained at the Q output until the enable is permitted to go high.

The '75, 'L75, and 'LS75 feature complementary Q and \bar{Q} outputs from a 4-bit latch, and are available in various 16-pin packages. For higher component density applications, the '77, 'L77, and 'LS77 4-bit latches are available in 14-pin flat packages.

These circuits are completely compatible with all popular TTL families. All inputs are diode-clamped to minimize transmission-line effects and simplify system design. Series 54, 54L, and 54LS devices are characterized for operation over the fully military temperature range of -55°C to 125°C ; Series 74, and 74LS devices are characterized for operation from 0°C to 70°C .

absolute maximum ratings over operating free-air temperature range (unless otherwise noted)

Supply voltage, V_{CC} (see Note 1)	7 V
Input voltage: '75, 'L75, '77, 'L77	5.5 V
'LS75, 'LS77	7 V
Interemitter voltage (see Note 2)	5.5 V
Operating free-air temperature range: SN54'	-55°C to 125°C
SN74'	0°C to 70°C
Storage temperature range	-65°C to 150°C

NOTES: 1. Voltage values are with respect to network ground terminal.

2. This is the voltage between two emitters of a multiple-emitter input transistor and is not applicable to the 'LS75 and 'LS77.

SN5475, SN54LS75 ... J OR W PACKAGE
 SN54L75 ... J PACKAGE
 SN7475 ... J OR N PACKAGE
 SN74LS75 ... D, J OR N PACKAGE
 (TOP VIEW)

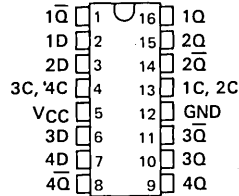

SN5477, SN54LS77 ... W PACKAGE
 SN54L77 ... T PACKAGE
 (TOP VIEW)

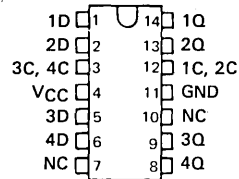

NC - No internal connection

FOR CHIP CARRIER INFORMATION,
 CONTACT THE FACTORY

3

TTL DEVICES

PRODUCTION DATA

This document contains information current as of publication date. Products conform to specifications per the terms of Texas Instruments standard warranty. Production processing does not necessarily include testing of all parameters.

TEXAS
 INSTRUMENTS

POST OFFICE BOX 225012 • DALLAS, TEXAS 75265

**TYPES SN5475, SN5477, SN54L75, SN54L77, SN54LS75, SN54LS77,
SN7475, SN74LS75
4-BIT BISTABLE LATCHES**

logic diagrams (each latch)

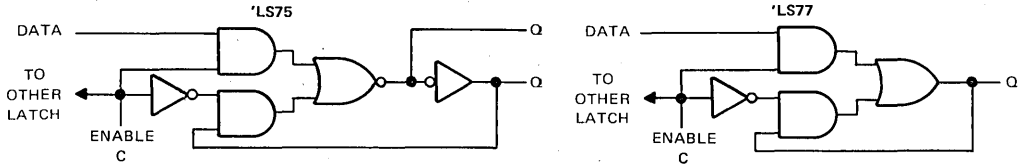
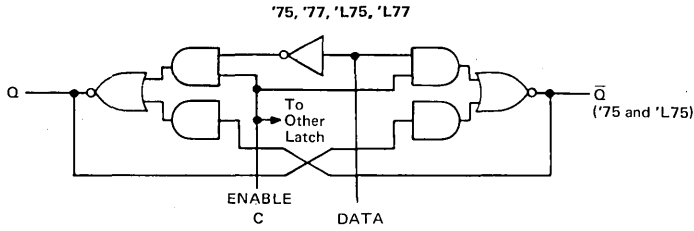

schematics of inputs and outputs

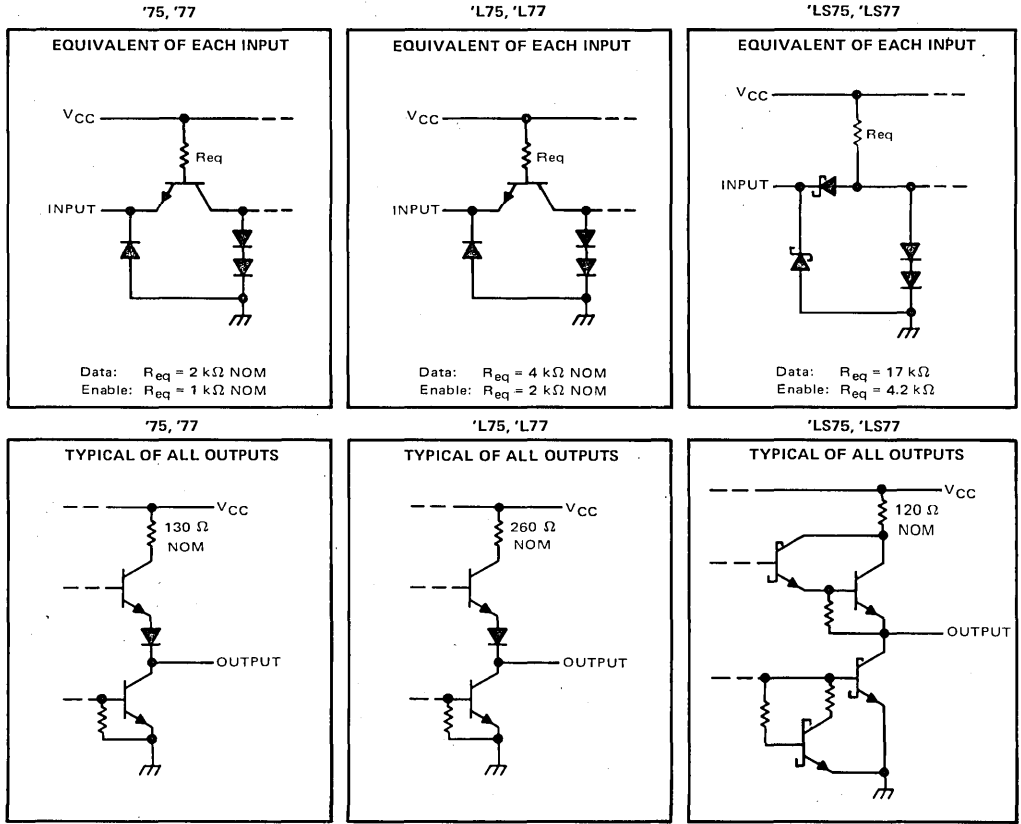

3 TTL DEVICES

TYPES SN5475, SN5477, SN7475 4-BIT BISTABLE LATCHES

recommended operating conditions

	SN5475, SN5477			SN7475			UNIT
	MIN	NOM	MAX	MIN	NOM	MAX	
Supply voltage, V_{CC}	4.5	5	5.5	4.75	5	5.25	V
High-level output current, I_{OH}				-400			μ A
Low-level output current, I_{OL}				16			mA
Width of enabling pulse, t_w	20			20			ns
Setup time, t_{SU}	20			20			ns
Hold time, t_h	5			5			ns
Operating free-air temperature, T_A	-55			125			$^{\circ}$ C

electrical characteristics over recommended operating free-air temperature range (unless otherwise noted)

PARAMETER		TEST CONDITIONS [†]	MIN	TYP [‡]	MAX	UNIT
V_{IH}	High-level input voltage		2			V
V_{IL}	Low-level input voltage				0.8	V
V_{IK}	Input clamp voltage	$V_{CC} = \text{MIN}$, $I_I = -12 \text{ mA}$			-1.5	V
V_{OH}	High-level output voltage	$V_{CC} = \text{MIN}$, $V_{IH} = 2 \text{ V}$, $V_{IL} = 0.8 \text{ V}$, $I_{OH} = -400 \mu\text{A}$	2.4	3.4		V
V_{OL}	Low-level output voltage	$V_{CC} = \text{MIN}$, $V_{IH} = 2 \text{ V}$, $V_{IL} = 0.8 \text{ V}$, $I_{OL} = 16 \text{ mA}$	0.2		0.4	V
I_I	Input current at maximum input voltage	$V_{CC} = \text{MAX}$, $V_I = 5.5 \text{ V}$			1	mA
I_{IH}	High-level input current	D input	$V_{CC} = \text{MAX}$, $V_I = 2.4 \text{ V}$		80	μ A
		C input			160	
I_{IL}	Low-level input current	D input	$V_{CC} = \text{MAX}$, $V_I = 0.4 \text{ V}$		-3.2	mA
		C input			-6.4	
I_{OS}	Short-circuit output current [§]	$V_{CC} = \text{MAX}$	SN54 [†]	-20	-57	mA
			SN74 [†]	-18	-57	
I_{CC}	Supply current	$V_{CC} = \text{MAX}$, See Note 3	SN54 [†]	32	46	mA
			SN74 [†]	32	53	

[†] For conditions shown as MIN or MAX, use the appropriate value specified under recommended operating conditions.

[‡] All typical values are at $V_{CC} = 5 \text{ V}$, $T_A = 25^{\circ}\text{C}$.

[§] Not more than one output should be shorted at a time.

NOTE 3: I_{CC} is tested with all inputs grounded and all outputs open.

switching characteristics, $V_{CC} = 5 \text{ V}$, $T_A = 25^{\circ}\text{C}$

PARAMETER	FROM (INPUT)	TO (OUTPUT)	TEST CONDITIONS	MIN	TYP	MAX	UNIT
t_{PLH}	D	Q	$C_L = 15 \text{ pF}$, $R_L = 400 \Omega$, See Figure 1	16		30	ns
t_{PHL}				14		25	
t_{PLH}^{\ddagger}	D	\bar{Q}		24		40	ns
t_{PHL}^{\ddagger}				7		15	
t_{PLH}	C	Q		16		30	ns
t_{PHL}				7		15	
t_{PLH}^{\ddagger}	C	\bar{Q}		16		30	ns
t_{PHL}^{\ddagger}				7		15	

t_{PLH} = propagation delay time, low-to-high-level output

t_{PHL} = propagation delay time, high-to-low-level output

[‡] These parameters are not applicable for the SN5477.



TTL DEVICES

TYPES SN54L75, SN54L77

4-BIT BISTABLE LATCHES

recommended operating conditions

	MIN	NOM	MAX	UNIT
V _{CC} Supply voltage	4.5	5	5.5	V
V _{IH} High-level input voltage	2			V
V _{IL} Low-level input voltage			0.8	V
I _{OH} High-level output current			-0.2	mA
I _{OL} Low-level output current			8	mA
t _w Width of enabling pulse	100			ns
t _{su} Setup time	40			ns
t _h Hold time	10			ns
T _A Operating free-air temperature	-55		125	°C

electrical characteristics over recommended operating free-air temperature range (unless otherwise noted)

PARAMETER	TEST CONDITIONS †	MIN	TYP ‡	MAX	UNIT
V _{IK}	V _{CC} = MIN, I _I = -12 mA			-1.5	V
V _{OH}	V _{CC} = MIN, V _{IH} = 2 V, V _{IL} = 0.8 V, I _{OH} = -0.2 mA	2.4	3.4		V
V _{OL}	V _{CC} = MIN, V _{IH} = 2 V, V _{IL} = 0.8 V, I _{OL} = 8 mA		0.2	0.4	V
I _I	V _{CC} = MAX, V _I = 5.5 V			1	mA
I _{IH}	V _{CC} = MAX, V _I = 2.4 V			40	μA
				80	
I _{IL}	V _{CC} = MAX, V _I = 0.4 V			-1.6	mA
				-3.2	
I _{OS} §	V _{CC} = MAX	-10		-29	mA
I _{CC}	V _{CC} = MAX, See Note 3		16	23	mA

† For conditions shown as MIN or MAX, use the appropriate value specified under recommended operating conditions.

‡ All typical values are at V_{CC} = 5 V, T_A = 25°C.

§ Not more than one output should be shorted at a time.

NOTE 3: I_{CC} is tested with all inputs grounded and all outputs open.

switching characteristics, V_{CC} = 5 V, T_A = 25°C

PARAMETER	FROM (INPUT)	TO (OUTPUT)	TEST CONDITIONS	MIN	TYP	MAX	UNIT
t _{PLH}	D	Q	R _L = 800 Ω, C _L = 15 pF See Figure 1	32	60		ns
t _{PHL}				28	50		ns
t _{PLH} ¶	D	Q̄		48	80		ns
t _{PLH} ¶				14	30		ns
t _{PLH}	C	Q		32	60		ns
t _{PHL}				14	30		ns
t _{PLH} ¶	C	Q̄		32	60		ns
t _{PLH} ¶				14	30		ns

¶ These parameters are not applicable for the SN54L77.

3 TTL DEVICES

TYPES SN54LS75, SN54LS77, SN74LS75 4-BIT BISTABLE LATCHES

recommended operating conditions

	SN54LS75 SN54LS77			SN74LS75			UNIT
	MIN	NOM	MAX	MIN	NOM	MAX	
Supply voltage, V_{CC}	4.5	5	5.5	4.75	5	5.25	V
High-level output current, I_{OH}	-400			-400			μ A
Low-level output current, I_{OL}	4			8			mA
Width of enabling pulse, t_w	20			20			ns
Setup time, t_{su}	20			20			ns
Hold time, t_h	5			5			ns
Operating free-air temperature, T_A	-55		125	0		70	$^{\circ}$ C

electrical characteristics over recommended operating free-air temperature range (unless otherwise noted)

PARAMETER	TEST CONDITIONS [†]	SN54LS75 SN54LS77			SN74LS75			UNIT
		MIN	TYP [‡]	MAX	MIN	TYP [‡]	MAX	
V_{IH} High-level input voltage		2			2			V
V_{IL} Low-level input voltage		0.7			0.8			V
V_{IK} Input clamp voltage	$V_{CC} = \text{MIN}$, $I_I = -18 \text{ mA}$	-1.5			-1.5			V
V_{OH} High-level output voltage	$V_{CC} = \text{MIN}$, $V_{IH} = 2 \text{ V}$, $V_{IL} = V_{IL \text{ max}}$, $I_{OH} = -400 \mu\text{A}$	2.5	3.5		2.7	3.5		V
V_{OL} Low-level output voltage	$V_{CC} = \text{MIN}$, $V_{IH} = 2 \text{ V}$, $V_{IL} = V_{IL \text{ max}}$	$I_{OL} = 4 \text{ mA}$ $I_{OL} = 8 \text{ mA}$		0.25	0.4	0.25	0.4	V
I_I Input current at maximum input voltage	$V_{CC} = \text{MAX}$, $V_I = 7 \text{ V}$			0.1		0.1		mA
I_{IH} High-level input current	$V_{CC} = \text{MAX}$, $V_I = 2.7 \text{ V}$	D input		20		20		μ A
		C input		80		80		
I_{IL} Low-level input current	$V_{CC} = \text{MAX}$, $V_I = 0.4 \text{ V}$	D input		-0.4		-0.4		mA
		C input		-1.6		-1.6		
I_{OS} Short-circuit output current [§]	$V_{CC} = \text{MAX}$	-20	-100	-20	-100	mA		
I_{CC} Supply current	$V_{CC} = \text{MAX}$, See Note 2	'LS75		6.3	12	6.3	12	mA
		'LS77		6.9	13			

[†] For conditions shown as MIN or MAX, use the appropriate value specified under recommended operating conditions.

[‡] All typical values are at $V_{CC} = 5 \text{ V}$, $T_A = 25^{\circ}\text{C}$.

[§] Not more than one output should be shorted at a time, and duration of the short-circuit should not exceed one second

NOTE 2: I_{CC} is tested with all inputs grounded and all outputs open.

switching characteristics, $V_{CC} = 5 \text{ V}$, $T_A = 25^{\circ}\text{C}$

PARAMETER [¶]	FROM (INPUT)	TO (OUTPUT)	TEST CONDITIONS	'LS75			'LS77			UNIT
				MIN	TYP	MAX	MIN	TYP	MAX	
t_{PLH}	D	Q	$C_L = 15 \text{ pF}$, $R_L = 2 \text{ k}\Omega$, See Figure 1	15	27		11	19	ns	
t_{PHL}				9	17	9	17			
t_{PLH}	D	\bar{Q}		12	20			ns		
t_{PHL}				7	15					
t_{PLH}	C	Q		15	27		10	18	ns	
t_{PHL}				14	25	10	18			
t_{PLH}	C	\bar{Q}		16	30			ns		
t_{PHL}				7	15					

[¶] t_{PLH} = propagation delay time, low-to-high-level output

t_{PHL} = propagation delay time, high-to-low-level output

3

TTL DEVICES

**TYPES SN5475, SN5477, SN54L75, SN54L77, SN54LS75, SN54LS77,
SN7475, SN74LS75
4-BIT BISTABLE LATCHES**

PARAMETER MEASUREMENT INFORMATION

switching characteristics †

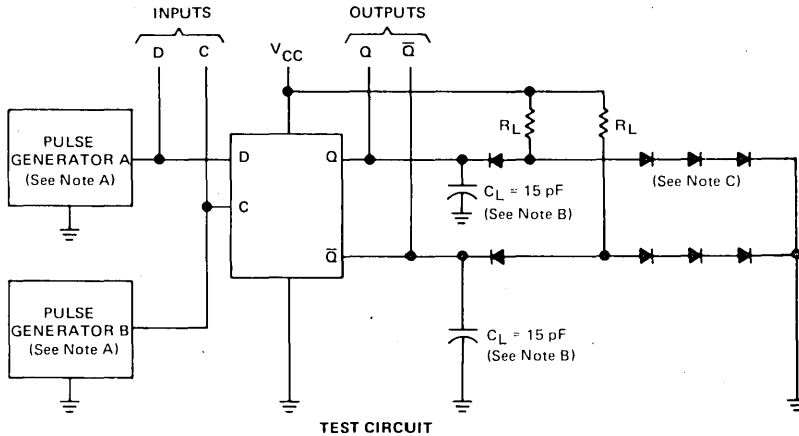

TEST CIRCUIT

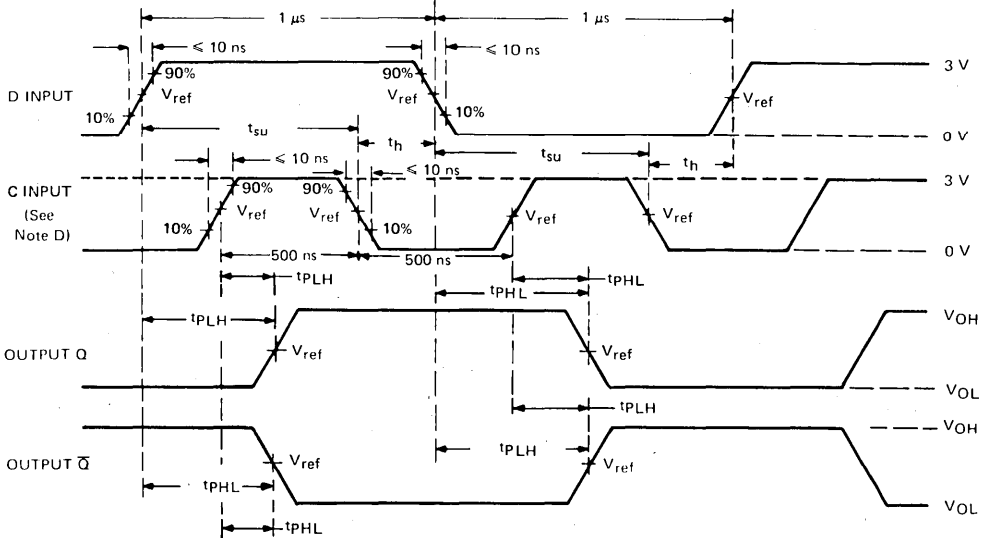

VOLTAGE WAVEFORMS

† Complementary Q outputs are on the '75, 'L75, and 'LS75 only.

- NOTES: A. The pulse generators have the following characteristics: $Z_{out} \approx 50 \Omega$; for pulse generator A, $PRR \leq 500 \text{ kHz}$; for pulse generator B, $PRR \leq 1 \text{ MHz}$. Positions of D and C input pulses are varied with respect to each other to verify setup times.
 B. C_L includes probe and jig capacitance.
 C. All diodes are 1N3064 or equivalent.
 D. When measuring propagation delay times from the D input, the corresponding C input must be held high.
 E. For '75, '77, 'L75, and 'L77, $V_{ref} = 1.5 \text{ V}$; for 'LS75 and 'LS77, $V_{ref} = 1.3 \text{ V}$.

FIGURE 1

TTL DEVICES

TYPES SN5476, SN54H76, SN54LS76A, SN7476, SN74H76, SN74LS76A DUAL J-K FLIP-FLOPS WITH PRESET AND CLEAR

REVISED DECEMBER 1983

- Package Options Include Plastic and Ceramic DIPs
- Dependable Texas Instruments Quality and Reliability

SN5476, SN54H76, SN54LS76A ... J OR W PACKAGE
SN7476, SN74H76 ... J OR N PACKAGE
SN74LS76A ... D, J OR N PACKAGE

(TOP VIEW)

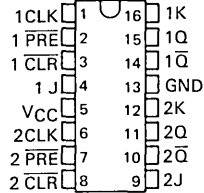

description

The '76 and 'H76 contain two independent J-K flip-flops with individual J-K, clock, preset, and clear inputs. The '76 and 'H76 are positive-edge-triggered flip-flops. J-K input is loaded into the master while the clock is high and transferred to the slave on the high-to-low transition. For these devices the J and K inputs must be stable while the clock is high.

The 'LS76A contain two independent negative-edge-triggered flip-flops. The J and K inputs must be stable one setup time prior to the high-to-low clock transition for predictable operation. The preset and clear are asynchronous active low inputs. When low they override the clock and data inputs forcing the outputs to the steady state levels as shown in the function table.

The SN5476, SN54H76, and the SN54LS76A are characterized for operation over the full military temperature range of -55°C to 125°C . The SN7476, SN74H76, and the SN74LS76A are characterized for operation from 0°C to 70°C .

'76, 'H76
FUNCTION TABLE

INPUTS					OUTPUTS	
PRE	CLR	CLK	J	K	Q	\bar{Q}
L	H	X	X	X	H	L
H	L	X	X	X	L	H
L	L	X	X	X	H [†]	H [†]
H	H	\downarrow	L	L	Q ₀	\bar{Q}_0
H	H	\downarrow	H	L	H	L
H	H	\downarrow	L	H	L	H
H	H	\downarrow	H	H	TOGGLE	
H	H	\downarrow	H	H	TOGGLE	

'LS76A
FUNCTION TABLE

INPUTS					OUTPUTS	
PRE	CLR	CLK	J	K	Q	\bar{Q}
L	H	X	X	X	H	L
H	L	X	X	X	L	H
L	L	X	X	X	H [†]	H [†]
H	H	\downarrow	L	L	Q ₀	\bar{Q}_0
H	H	\downarrow	H	L	H	L
H	H	\downarrow	L	H	L	H
H	H	\downarrow	H	H	TOGGLE	
H	H	\downarrow	H	H	TOGGLE	

[†] This configuration is nonstable; that is, it will not persist when either preset or clear returns to its inactive (high) level.

FOR CHIP CARRIER INFORMATION,
CONTACT THE FACTORY

PRODUCTION DATA

This document contains information current as of publication date. Products conform to specifications per the terms of Texas Instruments standard warranty. Production processing does not necessarily include testing of all parameters.

TEXAS
INSTRUMENTS

POST OFFICE BOX 225012 • DALLAS, TEXAS 75265

TI

TTL DEVICES

TYPES SN5476, SN54H76,
 SN7476, SN74H76
 DUAL J-K FLIP-FLOPS WITH PRESET AND CLEAR

logic diagrams

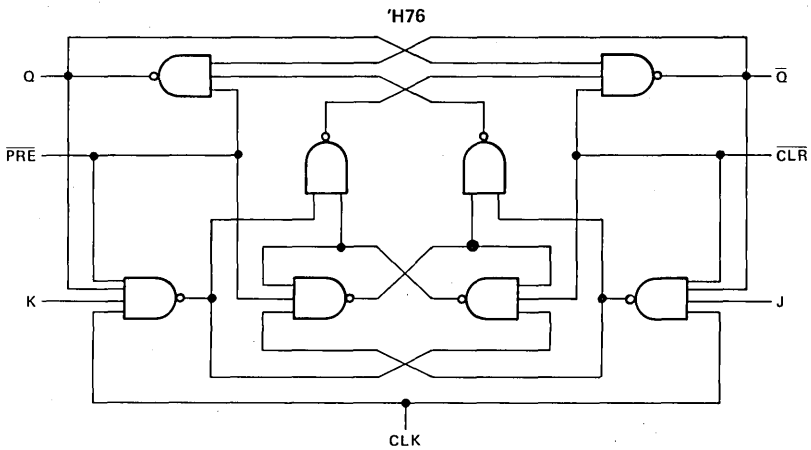
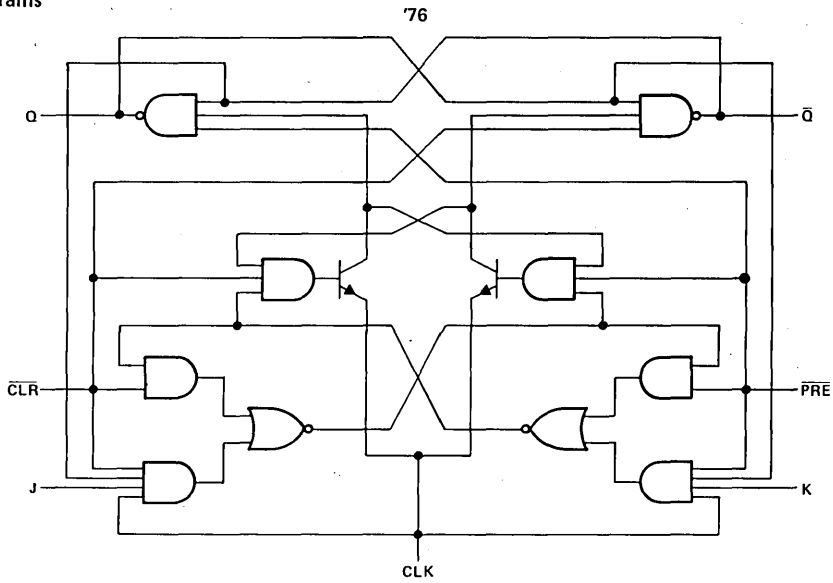

3

TTL DEVICES

TYPES SN5476, SN54H76, SN54LS76A,
SN7476, SN74H76, SN74LS76A
DUAL J-K FLIP-FLOPS WITH PRESET AND CLEAR

logic diagrams (continued)

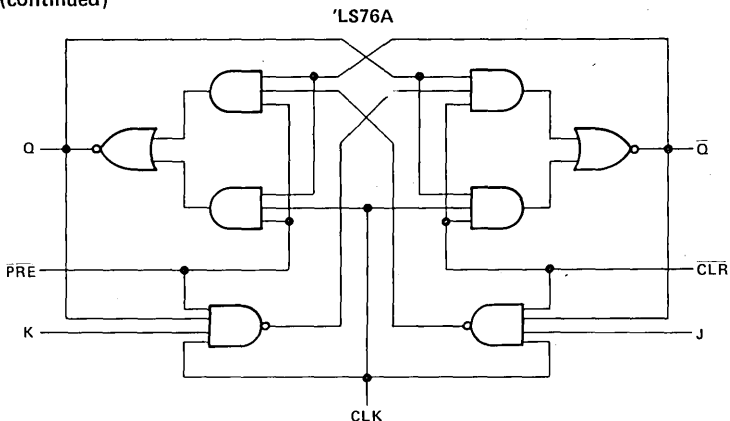

logic symbols

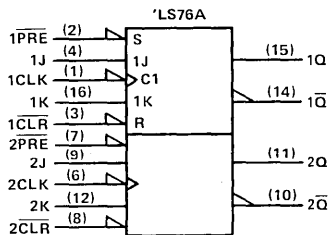
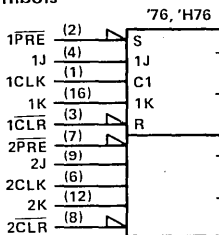

Pin numbers shown on logic notation are for D, J or N packages.

schematics of inputs and outputs

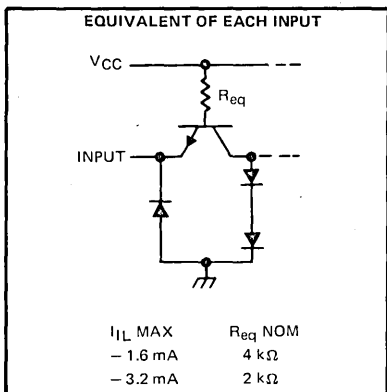

'76

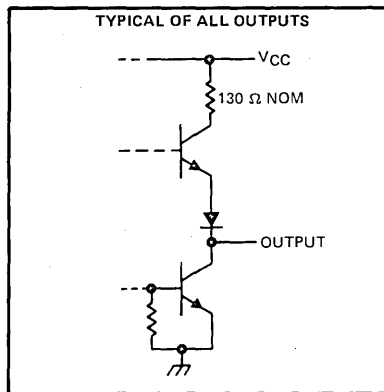

TTL DEVICES

TYPES SN5476, SN7476

DUAL J-K FLIP-FLOPS WITH PRESET AND CLEAR

recommended operating conditions

		SN5476			SN7476			UNIT
		MIN	NOM	MAX	MIN	NOM	MAX	
V_{CC}	Supply voltage	4.5	5	5.5	4.75	5	5.25	V
V_{IH}	High-level input voltage	2			2			V
V_{IL}	Low-level input voltage				0.8			V
I_{OH}	High-level output current				-0.4			mA
I_{OL}	Low-level output current				16			mA
t_w	Pulse duration	CLK high		20	20		ns	
		CLK low		47	47			
		PRE or CLR low		25	25			
t_{su}	Input setup time before CLK \uparrow	0			0			ns
t_h	Input hold time-data after CLK \downarrow	0			0			ns
T_A	Operating free-air temperature	-55	125		0	70		$^{\circ}$ C

electrical characteristics over recommended operating free-air temperature range (unless otherwise noted)

PARAMETER	TEST CONDITIONS \dagger	SN5476			SN7476			UNIT
		MIN	TYP	MAX	MIN	TYP	MAX	
V_{IK}	$V_{CC} = \text{MIN}, I_I = -12 \text{ mA}$	-1.5			-1.5			V
V_{OH}	$V_{CC} = \text{MIN}, V_{IH} = 2 \text{ V}, V_{IL} = 0.8 \text{ V}, I_{OH} = -0.4 \text{ mA}$	2.4	3.4		2.4	3.4		V
V_{OL}	$V_{CC} = \text{MIN}, V_{IH} = 2 \text{ V}, V_{IL} = 0.8 \text{ V}, I_{OL} = 16 \text{ mA}$		0.2	0.4		0.2	0.4	V
I_I	$V_{CC} = \text{MAX}, V_I = 5.5 \text{ V}$	1			1			mA
I_{IH}	J or K	40			40			μ A
	All other	80			80			
I_{IL}	J or K	-1.6			-1.6			mA
	All other \star	-3.2			-3.2			
$I_{OS}\S$	$V_{CC} = \text{MAX}$	-20	-57		-18	-57		mA
I_{CC}	$V_{CC} = \text{MAX},$ See Note 2	10	20		10	20		mA

\dagger For conditions shown as MIN or MAX, use the appropriate value specified under recommended operating conditions.

\ddagger All typical values are at $V_{CC} = 5 \text{ V}, T_A = 25^{\circ}\text{C}$.

\S Not more than one output should be shorted at a time.

\star Clear is tested with preset high and preset is tested with clear high.

NOTE 2: With all outputs open, I_{CC} is measured with the Q and \bar{Q} outputs high in turn. At the time of measurement, the clock input is grounded.

switching characteristics, $V_{CC} = 5 \text{ V}, T_A = 25^{\circ}\text{C}$ (see note 3)

PARAMETER	FROM (INPUT)	TO (OUTPUT)	TEST CONDITIONS		MIN	TYP	MAX	UNIT	
f_{max}			$R_L = 400 \Omega,$	$C_L = 15 \text{ pF}$	15	20		MHz	
t_{PLH}	PRE or CLR	Q or \bar{Q}				16	25		ns
t_{PHL}						25	40		ns
t_{PLH}	CLK	Q or \bar{Q}				16	25		ns
t_{PHL}						25	40		ns

NOTE 3: See General Information Section for load circuits and voltage waveforms.

3

TTL DEVICES

TYPES SN54H76, SN74H76

DUAL J-K FLIP-FLOPS WITH PRESET AND CLEAR

recommended operating conditions

		SN54H76			SN74H76			UNIT
		MIN	NOM	MAX	MIN	NOM	MAX	
V _{CC}	Supply voltage	4.5	5	5.5	4.75	5	5.25	V
V _{IH}	High-level input voltage	2			2			V
V _{IL}	Low-level input voltage				0.8			V
I _{OH}	High-level output current				-0.5			mA
I _{OL}	Low-level output current				20			mA
t _w	Pulse duration	CLK high		12	12		ns	
		CLK low		28	28			
		CLR or PRE low		16	16			
t _{SU}	Setup time before CLK↑	data high or low		0	0		ns	
t _H	Hold time-data after CLK↓			0	0		ns	
T _A	Operating free-air temperature	-55		125	0		70	°C

electrical characteristics over recommended operating free-air temperature range (unless otherwise noted)

PARAMETER	TEST CONDITIONS	SN54H76		SN74H76		UNIT
		MIN	TYP ‡ MAX	MIN	TYP ‡ MAX	
V _{IK}	V _{CC} = MIN, I _I = -8 mA	-1.5		-1.5		V
V _{OH}	V _{CC} = MIN, V _{IH} = 2 V, V _{IL} = 0.8 V, I _{OH} = -0.5 mA	2.4	3.4	2.4	3.4	V
V _{OL}	V _{CC} = MIN, V _{IH} = 2 V, V _{IL} = 0.8 V, I _{OL} = 20 mA	0.2	0.4	0.2	0.4	V
I _I	V _{CC} = MAX, V _I = 5.5 V	1		1		mA
I _{IH}	J, K, or CLK	50		50		μA
	CLR or PRE	100		100		
I _{IL}	J, K, or CLK	-2		-2		mA
	CLR or PRE*	-4		-4		
I _{OS} §	V _{CC} = MAX	-40	-100	-40	-100	mA
I _{CC}	V _{CC} = MAX, See Note 2	16	25	16	25	mA

† For conditions shown as MIN or MAX, use the appropriate value specified under recommended operating conditions.

‡ All typical values are at V_{CC} = 5 V, T_A = 25°C.

§ Not more than one output should be shorted at a time, and the duration of the short circuit should not exceed one second.

* Clear is tested with preset high and preset is tested with clear high.

NOTE 2: With all outputs open, I_{CC} is measured with the Q and \bar{Q} outputs high in turn. At the time of measurement, the clock input is grounded.

switching characteristics, V_{CC} = 5 V, T_A = 25°C (see note 3)

PARAMETER	FROM (INPUT)	TO (OUTPUT)	TEST CONDITIONS		MIN	TYP	MAX	UNIT	
f _{max}			R _L = 280 Ω, C _L = 25 pF		25	30		MHz	
t _{PLH}	$\overline{\text{PRE}}$ or $\overline{\text{CLR}}$	Q or \bar{Q}				6	13		ns
t _{PHL}						12	24		ns
t _{PLH}	CLK	Q or \bar{Q}				14	21		ns
t _{PHL}							22	27	

NOTE 3: See General Information Section for load circuits and voltage waveforms.

TYPES SN54LS76A, SN74LS76A DUAL J-K FLIP-FLOPS WITH PRESET AND CLEAR

recommended operating conditions

		SN54LS76A			SN74LS76A			UNIT
		MIN	NOM	MAX	MIN	NOM	MAX	
V _{CC}	Supply voltage	4.5	5	5.5	4.75	5	5.75	V
V _{IH}	High-level input voltage	2			2			V
V _{IL}	Low-level input voltage	0.7			0.8			V
I _{OH}	High-level output current	-0.4			-0.4			mA
I _{OL}	Low-level output current	4			8			mA
f _{clock}	Clock frequency	0			30			MHz
t _w	Pulse duration	CLK high		20		20		ns
		PRE or CLR low		25		25		
t _{su}	Setup time before CLK↓	data high or low		20		20		ns
		CLR inactive		20		20		
		PRE inactive		25		25		
t _h	Hold time-data after CLK↓	0			0			ns
T _A	Operating free-air temperature	-55			125			°C

electrical characteristics over recommended operating free-air temperature range (unless otherwise noted)

PARAMETER		TEST CONDITIONS†		SN54LS76A			SN74LS76A			UNIT
				MIN	TYP‡	MAX	MIN	TYP‡	MAX	
V _{IK}		V _{CC} = MIN, I _I = -18 mA		-1.5			-1.5			V
V _{OH}		V _{CC} = MIN, I _{OH} = -0.4 mA, V _{IH} = 2 V, V _{IL} = MAX,		2.5	3.4		2.7	3.4		V
V _{OL}		V _{CC} = MIN, I _{OL} = 4 mA, V _{IL} = MAX, V _{IH} = 2 V,		0.25	0.4		0.25	0.4		V
		V _{CC} = MIN, I _{OL} = 8 mA, V _{IL} = MAX, V _{IH} = 2 V,					0.35	0.5		
I _I	J or K	V _{CC} = MAX, V _I = 7 V		0.1			0.1			mA
	CLR or PRE			0.3			0.3			
	CLK			0.4			0.4			
I _{IH}	J or K	V _{CC} = MAX, V _I = 2.7 V		20			20			μA
	CLR or PRE			60			60			
	CLK			80			80			
I _{IL}	J or K	V _{CC} = MAX, V _I = 0.4 V		-0.4			-0.4			mA
	All other			-0.8			-0.8			
I _{OS} §		V _{CC} = MAX, See Note 4		-20	-100		-20	-100		mA
I _{CC}		V _{CC} = MAX, See Note 2		4			6			mA

† For conditions shown as MIN or MAX, use the appropriate value specified under recommended operating conditions.

‡ All typical values are at V_{CC} = 5 V, T_A = 25°C.

§ Not more than one output should be shorted at a time, and the duration of the short circuit should not exceed one second.

NOTE 2: With all outputs open, I_{CC} is measured with the Q and \bar{Q} outputs high in turn. At the time of measurement, the clock input is grounded.

NOTE 4: For certain devices where state commutation can be caused by shorting an output to ground, an equivalent test may be performed with V_O = 2.25 V and 2.125 V for the 54 family and the 74 family, respectively, with the minimum and maximum limits reduced to one half of their stated values.

switching characteristics, V_{CC} = 5 V, T_A = 25°C (see note 3)

PARAMETER	FROM (INPUT)	TO (OUTPUT)	TEST CONDITIONS		MIN	TYP	MAX	UNIT
f _{max}			R _L = 2 kΩ, C _L = 15 pF		30	45		MHz
t _{PLH}	PRE, CLR or CLK	Q or \bar{Q}			15	20		ns
t _{PHL}					15	20		ns

NOTE 3: See General Information Section for load circuits and voltage waveforms.

**TEXAS
INSTRUMENTS**

POST OFFICE BOX 225012 • DALLAS, TEXAS 75265

3-317

3
TTL DEVICES



TTL DEVICES

TYPES SN54H78, SN54L78, SN54LS78A, SN74H78, SN74LS78A

DUAL J-K FLIP-FLOPS WITH PRESET, COMMON CLOCK, AND COMMON CLEAR

REVISED DECEMBER 1983

- Package Options Include Plastic and Ceramic DIPs
- Dependable Texas Instruments Quality and Reliability

description

The 'H78 and 'L78 contain two J-K flip-flops with individual J-K, preset inputs, and common clock and common clear inputs. The 'H78 and 'L78 are positive pulse-triggered flip-flops. J-K input is loaded into the master while the clock is high and transferred to the slave on the high-to-low transition. For these devices the J and K inputs must be stable while the clock is high.

The 'LS78A contain two negative-edge-triggered flip-flops with individual J-K, preset inputs, and common clock and common clear inputs. The logic levels at the J and K inputs may be allowed to change while the clock pulse is high and the flip-flop will perform according to the function table as long as minimum setup and hold times are observed. The preset and clear are asynchronous active low inputs. When low they override the clock and data inputs forcing the outputs to the steady state levels as shown in the function table.

The SN54H78, SN54L78, and the SN54LS78A are characterized for operation over the full military temperature range of -55°C to 125°C. The SN74H78 and the SN74LS78A are characterized for operation from 0°C to 70°C.

FOR CHIP CARRIER INFORMATION,
CONTACT THE FACTORY

SN54H78 ... J PACKAGE
SN74H78 ... J OR N PACKAGE
(TOP VIEW)

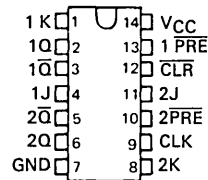

SN54L78 ... J PACKAGE
SN54LS78A ... J OR W PACKAGE
SN74LS78A ... D, J OR N PACKAGE
(TOP VIEW)

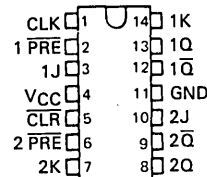

'H78, 'L78
FUNCTION TABLE

INPUTS					OUTPUTS	
PRE	CLR	CLK	J	K	Q	Q-bar
L	H	X	X	X	H	L
H	L	X	X	X	L	H
L	L	X	X	X	H†	H†
H	H	↓	L	L	Q ₀	Q ₀ -bar
H	H	↓	H	L	H	L
H	H	↓	L	H	L	H
H	H	↓	H	H	TOGGLE	
H	H	↓	H	H	Q ₀	Q ₀ -bar

'LS78A

INPUTS					OUTPUTS	
PRE	CLR	CLK	J	K	Q	Q-bar
L	H	X	X	X	H	L
H	L	X	X	X	L	H
L	L	X	X	X	H†	H†
H	H	↓	L	L	Q ₀	Q ₀ -bar
H	H	↓	H	L	H	L
H	H	↓	L	H	L	H
H	H	↓	H	H	TOGGLE	
H	H	↓	H	H	Q ₀	Q ₀ -bar

† This configuration is nonstable; that is, it will not persist when preset and clear inputs return to their inactive (high) level.

PRODUCTION DATA
This document contains information current as of publication date. Products conform to specifications per the terms of Texas Instruments standard warranty. Production processing does not necessarily include testing of all parameters.



POST OFFICE BOX 225012 • DALLAS, TEXAS 75265

TYPES SN54H78, SN54L78, SN74H78
 DUAL J-K FLIP-FLOPS WITH PRESET, COMMON CLOCK, AND COMMON CLEAR

logic diagrams

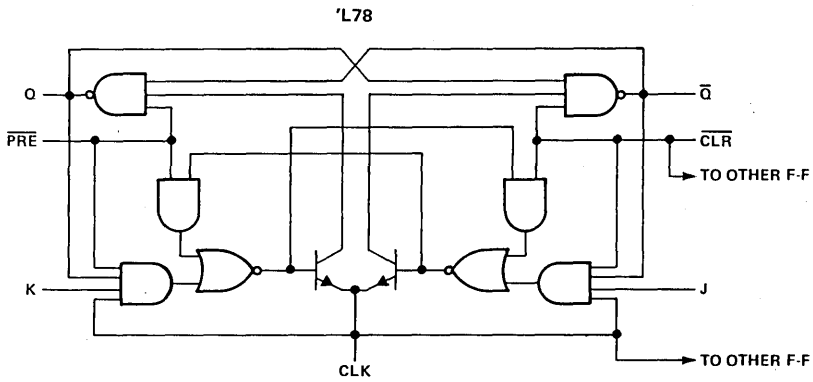
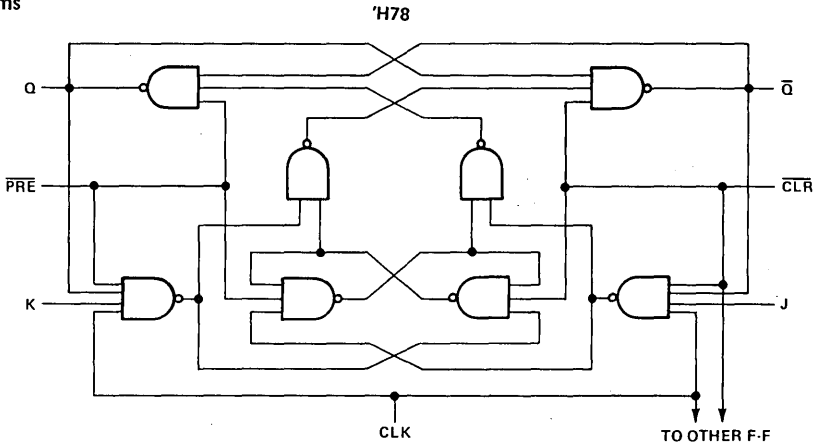

3

TTL DEVICES

DUAL J-K FLIP-FLOPS WITH PRESET, COMMON CLOCK, AND COMMON CLEAR

logic diagrams (continued)

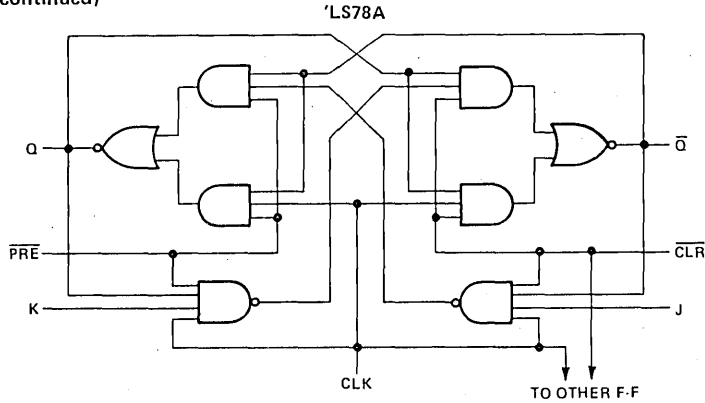

logic symbols

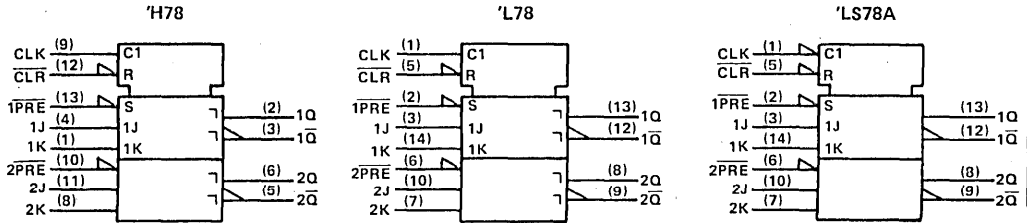

Pin numbers shown on logic notation are for D, J or N packages.

schematics of inputs and outputs

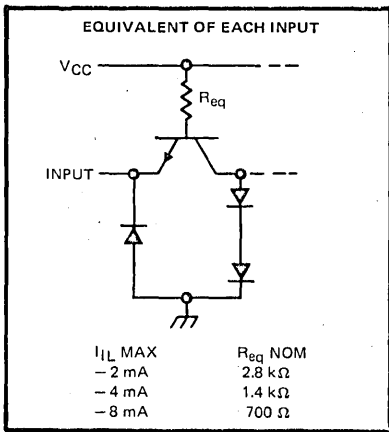

'H78

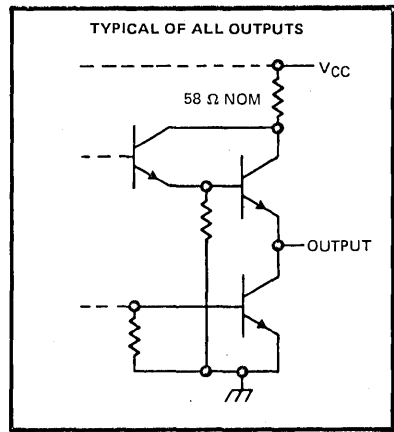

TTL DEVICES

DUAL J-K FLIP-FLOPS WITH PRESET, COMMON CLEAR, AND COMMON CLOCK

TYPES SN54H78, SN74H78

recommended operating conditions

		SN54H78			SN74H78			UNIT
		MIN	NOM	MAX	MIN	NOM	MAX	
V _{CC}	Supply voltage	4.5	5	5.5	4.75	5	5.25	V
V _{IH}	High-level input voltage	2			2			V
V _{IL}	Low-level input voltage				0.8			V
I _{OH}	High-level output current				-0.5			mA
I _{OL}	Low-level output current				20			mA
t _w	Pulse duration	CLK high		12	12		ns	
		CLK low		28	28			
		CLR or PRE low		16	16			
t _{su}	Setup time before CLK †	data high or low		0	0		ns	
t _h	Hold time-data after CLK †			0	0		ns	
T _A	Operating free-air temperature	-55		125	0		70	°C

electrical characteristics over recommended operating free-air temperature range (unless otherwise noted)

PARAMETER	TEST CONDITIONS†	SN54H78			SN74H78			UNIT
		MIN	TYP‡	MAX	MIN	TYP‡	MAX	
V _{IK}	V _{CC} = MIN, I _I = -8 mA	-1.5			-1.5			V
V _{OH}	V _{CC} = MIN, V _{IH} = 2 V, V _{IL} = 0.8 V, I _{OH} = -0.5 mA	2.4	3.4		2.4	3.4	V	
V _{OL}	V _{CC} = MIN, V _{IH} = 2 V, V _{IL} = 0.8 V, I _{OL} = 20 mA		0.2	0.4		0.2	0.4	V
I _I	V _{CC} = MAX, V _I = 5.5 V	1			1			mA
I _{IH}	J or K	50			50			μA
	CLR	200			200			
	PRE or CLK	100			100			
I _{IL}	J or K	-2			-2			mA
	CLR*	-8			-8			
	PRE*	-4			-4			
	CLK	-4			-4			
I _{OS} §	V _{CC} = MAX	-40	-100		-40	-100	mA	
I _{CC}	V _{CC} = MAX, See Note 2	16	25		16	25	mA	

† For conditions shown as MIN or MAX, use the appropriate value specified under recommended operating conditions.

‡ All typical values are at V_{CC} = 5 V, T_A = 25°C.

§ Not more than output should be shorted at a time, and the duration of the short circuit should not exceed one second.

* Clear is tested with preset high and preset is tested with clear high.

NOTE 2: With all outputs open, I_{CC} is measured with the Q and \bar{Q} outputs high in turn. At the time of measurement, the clock input is grounded.

switching characteristics, V_{CC} = 5 V, T_A = 25°C (see note 3)

PARAMETER	FROM (INPUT)	TO (OUTPUT)	TEST CONDITIONS		MIN	TYP	MAX	UNIT
f _{max}					25	30		MHz
t _{PLH}	CLR or PRE	Q or \bar{Q}	R _L = 280 Ω,	C _L = 25 pF	6	13		ns
t _{PHL}					12	24		ns
t _{PLH}	CLK	Q or \bar{Q}			14	21		ns
t _{PHL}					22	27		ns

NOTE 3: See General Information Section for load circuits and voltage waveforms.

TYPE SN54L78 DUAL J-K FLIP-FLOPS WITH PRESET, COMMON CLOCK, AND COMMON CLEAR

recommended operating conditions

	MIN	NOM	MAX	UNIT
V _{CC} Supply voltage	4.5	5	5.5	V
V _{IH} High-level input voltage	2			V
V _{IL} Low-level input voltage	Clock input		0.6	V
	All other inputs		0.7	
I _{OH} High-level output current			-0.1	mA
I _{OL} Low-level output current			2	mA
t _w Pulse duration	CLK high or low		200	ns
	CLR or PRE low		100	
t _{su} Setup time before CLK †	0			ns
t _h Hold time-data after CLK †	0			ns
T _A Operating free-air temperature	-55		125	°C

electrical characteristics over recommended operating free-air temperature range (unless otherwise noted)

PARAMETER		TEST CONDITIONS†		MIN	TYP‡	MAX	UNIT
V _{OH}		V _{CC} = MIN, V _{IH} = 2 V, V _{IL} = MAX, I _{OH} = -0.1 mA		2.4	3.3		V
V _{OL}		V _{CC} = MIN, V _{IH} = 2 V, V _{IL} = MAX, I _{OL} = 2 mA		0.15			V
I _I	J or K	V _{CC} = MAX, V _I = 5.5 V			0.1		mA
	PRE				0.2		
	CLK or CLR				0.4		
I _{IH}	J or K	V _{CC} = MAX, V _I = 2.4 V			10		μA
	CLR				40		
	PRE				20		
	CLK				-400		
I _{IL}	J or K	V _{CC} = MAX, V _I = 0.3 V			-0.18		mA
	PRE				-0.36		
	CLK or CLR				-0.72		
I _{OS}		V _{CC} = MAX		-3		-15	mA
I _{CC}		V _{CC} = MAX, See Note 2			0.76	1.44	mA

† For conditions shown as MIN or MAX, use the appropriate value specified under recommended operating conditions.

‡ All typical values are at V_{CC} = 5 V, T_A = 25°C.

NOTE 2: With all outputs open, I_{CC} is measured with the Q and \bar{Q} outputs high in turn. At the time of measurement the clock input is grounded.

switching characteristics, V_{CC} = 5 V, T_A = 25°C (see note 3)

PARAMETER	FROM (INPUT)	TO (OUTPUT)	TEST CONDITIONS	MIN	TYP	MAX	UNIT
f _{max}			R _L = 4 kΩ, C _L = 50 pF	2.5	3		MHz
t _{PLH}	PRE or CLR	Q or \bar{Q}		35	75		ns
t _{PHL}	PRE or CLR (CLK high)	\bar{Q} or Q		60	150		ns
	PRE or CLR (CLK low)			200			
t _{PLH}	CLK	Q or \bar{Q}		10	35	75	ns
t _{PHL}				10	60	150	

NOTE 3: See General Information Section for load circuits and voltage waveforms.

TYPES SN54LS78A, SN74LS78A
DUAL J-K FLIP-FLOPS WITH PRESET, COMMON CLOCK, AND COMMON CLEAR

recommended operating conditions

		SN54LS78A			SN74LS78A			UNIT
		MIN	NOM	MAX	MIN	NOM	MAX	
V _{CC}	Supply voltage	4.5	5	5.5	4.75	5	5.75	V
V _{IH}	High-level input voltage	2			2			V
V _{IL}	Low-level input voltage			0.7			0.8	V
I _{OH}	High-level output current			-0.4			-0.4	mA
I _{OL}	Low-level output current			4			8	mA
f _{clock}	Clock frequency	0		30	0		30	MHz
t _w	Pulse duration	CLK high		20	20			ns
		PRE or CLR low		25	25			
t _{su}	Setup time before CLK ↓	data high or low		20	20			ns
		PRE or CLR inactive		20	20			
t _h	Hold time-data after CLK ↓	0		0	0			ns
T _A	Operating free-air temperature	-55		125	0		70	°C

electrical characteristics over recommended operating free-air temperature range (unless otherwise noted)

PARAMETER		TEST CONDITIONS†			SN54LS78A		SN74LS78A		UNIT
					MIN	TYP‡	MAX	MIN	
V _{IK}		V _{CC} = MIN, I _I = -18 mA			-1.5		-1.5		V
V _{OH}		V _{CC} = MIN, I _{OH} = -0.4 mA, V _{IH} = 2 V, V _{IL} = 0.7 V		2.5	3.4				V
		V _{CC} = MIN, I _{OH} = -0.4 mA, V _{IH} = 2 V, V _{IL} = 0.8 V				2.7 3.4			
V _{OL}		V _{CC} = MIN, I _{OL} = 4 mA, V _{IL} = MAX, V _{IH} = 2 V		0.25	0.4		0.25	0.4	V
		V _{CC} = MIN, I _{OL} = 8 mA, V _{IL} = MAX, V _{IH} = 2 V				0.35 0.5			
I _I	J or K	V _{CC} = MAX, V _I = 7 V		0.1		0.1		mA	
	CLR		0.6		0.6				
	PRE		0.3		0.3				
	CLK		0.8		0.8				
I _{IH}	J or K	V _{CC} = MAX, V _I = 2.7 V		20		20		μA	
	CLR		120		120				
	PRE		60		60				
	CLK		160		160				
I _{IL}	J or K	V _{CC} = MAX, V _I = 0.4 V		-0.4		-0.4		mA	
	CLR		-1.6		-1.6				
	PRE		-0.8		-0.8				
	CLK		-1.6		-1.6				
I _{OS} §		V _{CC} = MAX, See Note 4		-20	-100		-20	-100	mA
I _{CC}		V _{CC} = MAX, See Note 2		4 6		4 6		mA	

† For conditions shown as MIN or MAX, use the appropriate value specified under recommended operating conditions.

‡ All typical values are at V_{CC} = 5 V, T_A = 25°C.

§ Not more than one output should be shorted at a time, and the duration of the short circuit should not exceed one second.

NOTE 2: With all outputs open, I_{CC} is measured with the Q and Q̄ outputs high in turn. At the time of measurement, the clock input is grounded.

NOTE 4: For certain devices where state commutation can be caused by shorting an output to ground, an equivalent test may be performed with V_O = 2.25 V and 2.125 V for the 54 family and the 74 family, respectively, with the minimum and maximum limits reduced to one half of their stated values.

3

TTL DEVICES

TYPES SN54LS78A, SN74LS78A
DUAL J-K FLIP-FLOPS WITH PRESET, COMMON CLOCK, AND COMMON CLEAR

switching characteristics, $V_{CC} = 5\text{ V}$, $T_A = 25^\circ\text{C}$ (see note 3)

PARAMETER	FROM (INPUT)	TO (OUTPUT)	TEST CONDITIONS	MIN	TYP	MAX	UNIT
f_{\max}				30	45		MHz
t_{PLH}	$\overline{\text{PRE}}$, $\overline{\text{CLR}}$ or CLK	Q or $\overline{\text{Q}}$	$R_L = 2\text{ k}\Omega$, $C_L = 15\text{ pF}$		15	20	ns
t_{PHL}					15	20	ns

NOTE 3: See General Information Section for load circuits and voltage waveforms.

TYPES SN5480, SN7480 GATED FULL ADDERS

DECEMBER 1972 — REVISED DECEMBER 1983

logic

SN5480 ... J PACKAGE
SN7480 ... J OR N PACKAGE

SN5480 ... W PACKAGE

FUNCTION TABLE
(See Notes 1, 2, and 3)

INPUTS			OUTPUTS		
C _n	B	A	C _{n+1}	Σ	Σ̄
L	L	L	H	H	L
L	L	H	H	L	H
L	H	L	H	L	H
L	H	H	L	H	L
H	L	L	H	L	H
H	L	H	L	H	L
H	H	L	L	H	L
H	H	H	L	L	H

H = high level, L = low level

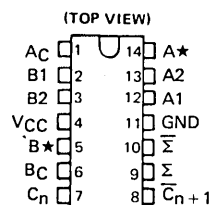
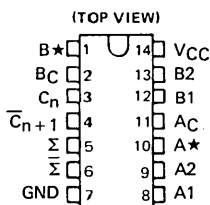

- NOTES: 1. $A = \bar{A}_C + \bar{A}^* + A1 \cdot A2$, $B = \bar{B}_C + \bar{B}^* + B1 \cdot B2$.
 2. When A* is used as an input, A1 or A2 must be low. When B* is used as an input, B1 or B2 must be low.
 3. When A1 and A2 or B1 and B2 are used as inputs, A* or B*, respectively, must be open or used to perform dot-AND logic.

description

These single-bit, high-speed, binary full adders with gated complementary inputs, complementary sum (Σ and $\bar{\Sigma}$) outputs and inverted carry output are designed for medium-and high-speed, multiple-bit, parallel-add/serial-carry application. These circuits (see schematic) utilize diode-transistor logic (DTL) for the gated inputs, and high-speed, high-fan-out transistor-transistor logic (TTL) for the sum and carry outputs and are entirely compatible with the TTL logic families. The implementation of a single-inversion, high-speed, Darlington-connected serial-carry circuit minimizes the necessity for extensive "look-ahead" and carry-cascading circuits.

absolute maximum ratings over operating free-air temperature range (unless otherwise noted)

Supply voltage, V_{CC} (see Note 4)	7 V
Input voltage (see Note 5)	5.5 V
Operating free-air temperature range: SN5480 Circuits	-55°C to 125°C
SN7480 Circuits	0° to 70°C
Storage temperature range	-65°C to 150°C

- NOTES: 4. Voltage values are with respect to network ground terminal.
 5. Input signals must be zero or positive with respect to network ground terminal.

recommended operating conditions

	SN5480			SN7480			UNIT
	MIN	NOM	MAX	MIN	NOM	MAX	
Supply voltage, V_{CC}	4.5	5	5.5	4.75	5	5.25	V
High-level output current, I_{OH}	Σ or $\bar{\Sigma}$		-400			-400	μ A
	\bar{C}_{n+1}		-200			-200	
	A* or B*		-120			-120	
Low-level output current, I_{OL}	Σ or $\bar{\Sigma}$		16			16	mA
	\bar{C}_{n+1}		8			8	
	A* or B*		4.8			4.8	
Operating free-air temperature, T_A	-55		125	0		70	°C

PRODUCTION DATA
 This document contains information current as of publication date. Products conform to specifications per the terms of Texas Instruments standard warranty. Production processing does not necessarily include testing of all parameters.

TEXAS
INSTRUMENTS

POST OFFICE BOX 225012 • DALLAS, TEXAS 75265

3
TTL DEVICES

TYPES SN5480, SN7480 GATED FULL ADDERS

electrical characteristics over recommended operating free-air temperature range (unless otherwise noted)

PARAMETER		TEST CONDITIONS†		SN5480			SN7480			UNIT	
				MIN	TYP‡	MAX	MIN	TYP‡	MAX		
V _{IH}	High-level input voltage			2			2			V	
V _{IL}	Low-level input voltage			0.8			0.8			V	
V _{OH}	High-level output voltage	Σ or $\bar{\Sigma}$	V _{CC} = MIN, V _{IH} = 2 V, V _{IL} = 0.8 V	I _{OH} = -400 μ A			2.4 3.5			V	
		\bar{C}_{n+1}		I _{OH} = -200 μ A							
		A* or B*		I _{OH} = -120 μ A							
V _{OL}	Low-level output voltage	Σ or $\bar{\Sigma}$	V _{CC} = MIN, V _{IH} = 2 V, V _{IL} = 0.8 V	I _{OL} = 16 mA			0.22 0.4			V	
		\bar{C}_{n+1}		I _{OL} = 8 mA							
		A* or B*		I _{OL} = 4.8 mA							
I _I	Input current at maximum input voltage	V _{CC} = MAX, V _I = 5.5 V		1			1			mA	
I _{IH}	High-level input current	A ₁ , A ₂ , B ₁ , B ₂ , A _C or B _C	V _{CC} = MAX, V _I = 2.4 V	15			15			μ A	
		A* or B*		-1.1			-1.1				
		C _n		200			200				
I _{IL}	Low-level input current	A ₁ , A ₂ , B ₁ , B ₂ , A _C or B _C	V _{CC} = MAX, V _I = 0.4 V	-1.6			-1.6			mA	
		A* or B*		-2.6			-2.6				
		C _n		-8			-8				
I _{OS}	Short-circuit output-current §	Σ or $\bar{\Sigma}$	V _{CC} = MAX	-20		-57		-18		-57	
		\bar{C}_{n+1}		-20		-70		-18		-70	
		A* or B*		-0.9		-2.9		-0.9		-2.9	
I _{CC}	Supply current	V _{CC} = MAX, See Note 6		21 31			21 35			mA	

† For conditions shown as MIN or MAX, use the appropriate value specified under recommended operating conditions for the applicable type.

‡ All typical values are at V_{CC} = 5 V, T_A = 25°C.

§ Not more than one output should be shorted at a time.

NOTE 6: I_{CC} is measured with all inputs and outputs open.

switching characteristics, V_{CC} = 5 V, T_A = 25°C

PARAMETER¶	FROM INPUT	TO OUTPUT	TEST CONDITIONS	MIN	TYP	MAX	UNIT
t _{PLH}	C _n	\bar{C}_{n+1}	C _L = 15 pF, R _L = 780 Ω , See Note 7	13 17		ns	
t _{PHL}				8 12			
t _{PLH}	B _C	\bar{C}_{n+1}		18 25			
t _{PHL}				38 55			
t _{PLH}	A _C	Σ	C _L = 15 pF, R _L = 400 Ω , See Note 7	52 70		ns	
t _{PHL}				62 80			
t _{PLH}	B _C	$\bar{\Sigma}$		38 55			
t _{PHL}				56 75			
t _{PLH}	A ₁	A*	C _L = 15 pF, See Note 7	48 65		ns	
t _{PHL}				17 25			
t _{PLH}	B ₁	B*		48 65			
t _{PHL}				17 25			

¶ t_{PLH} \equiv propagation delay time, low-to-high-level output

t_{PHL} \equiv propagation delay time, high-to-low-level output

NOTE 7: The load for testing outputs A* and B* consists only of capacitance C_L to ground. See General Information Section for load circuits and voltage waveforms.

3

TTL DEVICES

logic diagram

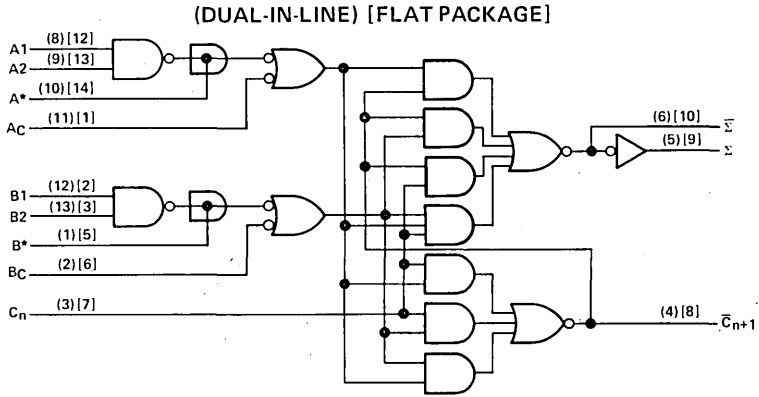

schematic

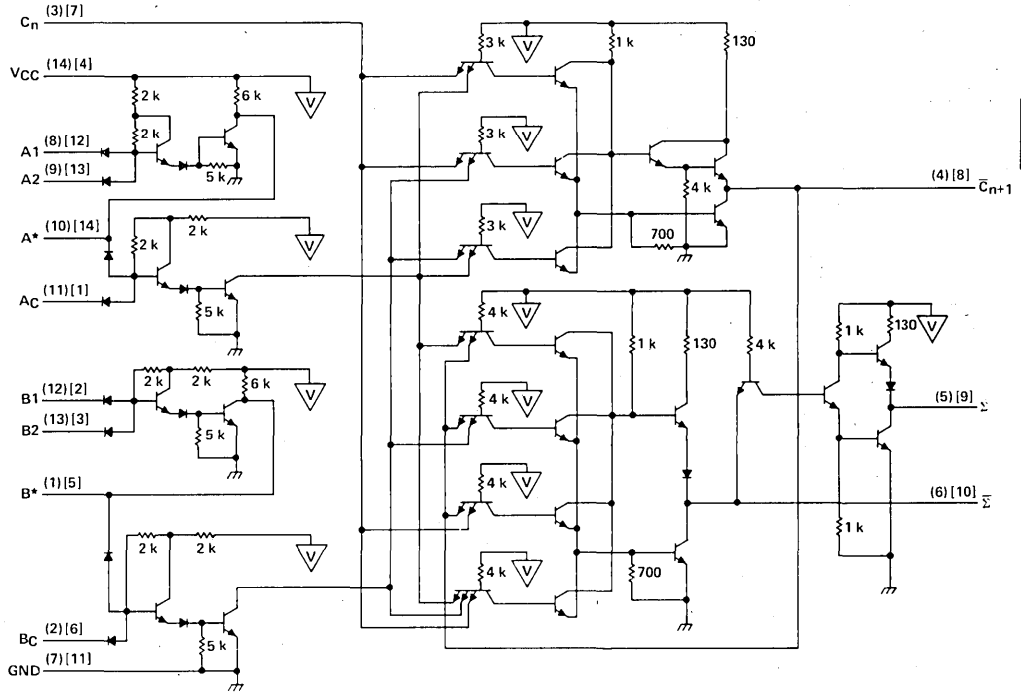

▽ ... VCC bus

Resistor values shown are nominal and in ohms.

Pin numbers shown in () are for the N or J package and pin numbers shown in [] are for the W package.

3
TTL DEVICES

TYPES SN5482, SN7482 2-BIT BINARY FULL ADDERS

DECEMBER 1972—REVISED DECEMBER 1983

For applications in:

- Digital Computer Systems
- Data-Handling Systems
- Control Systems

logic

SN5482 ... J OR W PACKAGE
SN7482 ... J OR N PACKAGE
(TOP VIEW)

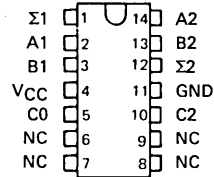

NC—No internal connection

FUNCTION TABLE

INPUTS				OUTPUTS					
A1	B1	A2	B2	WHEN C0 = L			WHEN C0 = H		
				Σ1	Σ2	C2	Σ1	Σ2	C2
L	L	L	L	L	L	L	H	L	L
H	L	L	L	H	L	L	L	H	L
L	H	L	L	H	L	L	L	H	L
H	H	L	L	L	H	L	H	H	L
L	L	H	L	L	H	L	H	H	L
H	L	H	L	H	H	L	L	L	H
L	H	H	L	H	H	L	L	L	H
H	H	H	L	L	L	H	H	L	H
L	L	L	H	L	H	L	H	H	L
H	L	L	H	H	H	L	L	L	H
L	H	L	H	H	H	L	L	L	H
H	H	L	H	L	L	H	H	L	H
L	L	H	H	L	L	H	H	L	H
H	L	H	H	H	L	H	L	H	H
L	H	H	H	H	L	H	L	H	H
H	H	H	H	L	H	H	H	H	H

H = high level, L = low level

description

These full adders perform the addition of two 2-bit binary numbers. The sum (Σ) outputs are provided for each bit and the resultant carry (C2) is obtained from the second bit. Designed for medium-to-high-speed, multiple-bit, parallel-add/serial-carry applications, these circuits utilize high-speed, high-fan-out transistor-transistor logic (TTL) and are compatible with both DTL and TTL logic families. The implementation of a single-inversion, high-speed, Darlington-connected serial-carry circuit within each bit minimizes the necessity for extensive "look-ahead" and carry-cascading circuits.

logic diagram

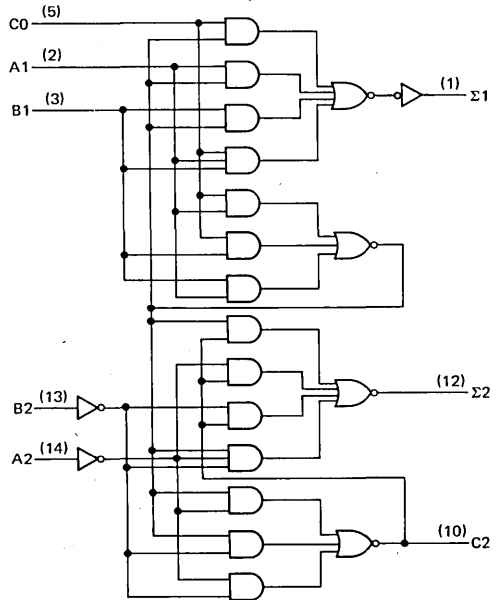

Pin numbers shown on logic notation are for J or N packages.

PRODUCTION DATA

This document contains information current as of publication date. Products conform to specifications per the terms of Texas Instruments standard warranty. Production processing does not necessarily include testing of all parameters.

TYPES SN5482, SN7482 2-BIT BINARY FULL ADDERS

absolute maximum ratings over operating free-air temperature range (unless otherwise noted)

Supply voltage, V_{CC} (see Note 1)	7 V
Input voltage (see Note 2)	5.5 V
Operating free-air temperature range: SN5482 Circuits	-55°C to 125°C
SN7482 Circuits	0°C to 70°C
Storage temperature range	-65°C to 150°C

- NOTES: 1. Voltage values are with respect to network ground terminal.
2. Input signals must be zero or positive with respect to network ground terminal.

recommended operating conditions

	SN5482			SN7482			UNIT
	MIN	NOM	MAX	MIN	NOM	MAX	
Supply voltage, V_{CC}	4.5	5	5.5	4.75	5	5.25	V
High-level output current, I_{OH}	$\Sigma 1$ or $\Sigma 2$		-400			-400	μA
	C2		-200			-200	
Low-level output current, I_{OL}	$\Sigma 1$ or $\Sigma 2$		16			16	mA
	C2		8			8	
Operating free-air temperature, T_A	-55		125	0		70	°C

electrical characteristics over recommended operating free-air temperature range (unless otherwise noted)

PARAMETER		TEST CONDITIONS†	SN5482			SN7482			UNIT		
			MIN	TYP‡	MAX	MIN	TYP‡	MAX			
V_{IH}	High-level input voltage		2			2			V		
V_{IL}	Low-level input voltage		0.8			0.8			V		
V_{OH}	High-level output voltage	$\Sigma 1$ or $\Sigma 2$	2.4		3.4		2.4		3.4		V
		C2									
V_{OL}	Low-level output voltage	$\Sigma 1$ or $\Sigma 2$	0.2		0.4		0.2		0.4		V
		C2									
I_I	Input current at maximum input voltage	$V_{CC} = \text{MAX}, V_I = 5.5 \text{ V}$	1			1			mA		
I_{IH}	High-level input current	A1, B1, or C0	160			160			μA		
		A2 or B2	40			40					
I_{IL}	Low-level input current	A1, B1, or C0	-6.4			-6.4			mA		
		A2 or B2	-1.6			-1.6					
I_{OS}	Short-circuit output current §	$\Sigma 1$ or $\Sigma 2$	-20		-55		-18		-55		mA
		C2	-20		-70		-18		-70		
I_{CC}	Supply current	$V_{CC} = \text{MAX},$ See Note 3	35	50	35	58	mA				

† For conditions shown as MIN or MAX, use the appropriate value specified under recommended operating conditions for the applicable type.

‡ All typical values are at $V_{CC} = 5 \text{ V}, T_A = 25^\circ \text{C}$.

§ Not more than one output should be shorted at a time.

NOTE 3: I_{CC} is measured with outputs open, B1 and B2 grounded, and 4.5 V applied to A1, A2, and C0.



TTL DEVICES

TYPES SN5482, SN7482 2-BIT BINARY FULL ADDERS

switching characteristics, $V_{CC} = 5\text{ V}$, $T_A = 25^\circ\text{C}$ (see note 4)

PARAMETER [†]	FROM (INPUT)	TO (OUTPUT)	TEST CONDITIONS	MIN	TYP	MAX	UNIT
t_{PLH}	C0	$\Sigma 1$	$C_L = 15\text{ pF}$, $R_L = 400\ \Omega$			34	ns
t_{PHL}				40			
t_{PLH}	B2	$\Sigma 2$		40	ns		
t_{PHL}				35			
t_{PLH}	C0	$\Sigma 2$		38	ns		
t_{PHL}				42			
t_{PLH}	C0	C2	$C_L = 15\text{ pF}$, $R_L = 780\ \Omega$	12	19	ns	
t_{PHL}				17	27		

[†] t_{PLH} = propagation delay time, low-to-high-level output

t_{PHL} = propagation delay time, high-to-low-level output

NOTE 4: See General Information Section for load circuits and voltage waveforms.

schematics of inputs and outputs

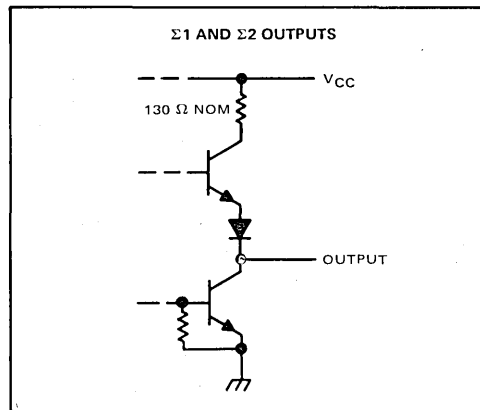
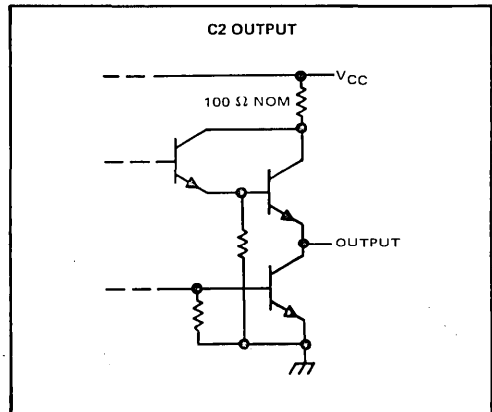
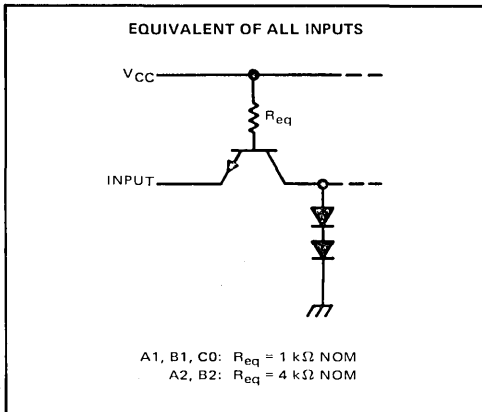

3

TTL DEVICES

TYPES SN5483A, SN54LS83A, SN7483A, SN74LS83A
4-BIT BINARY FULL ADDERS WITH FAST CARRY

schematics of inputs and outputs

'83A

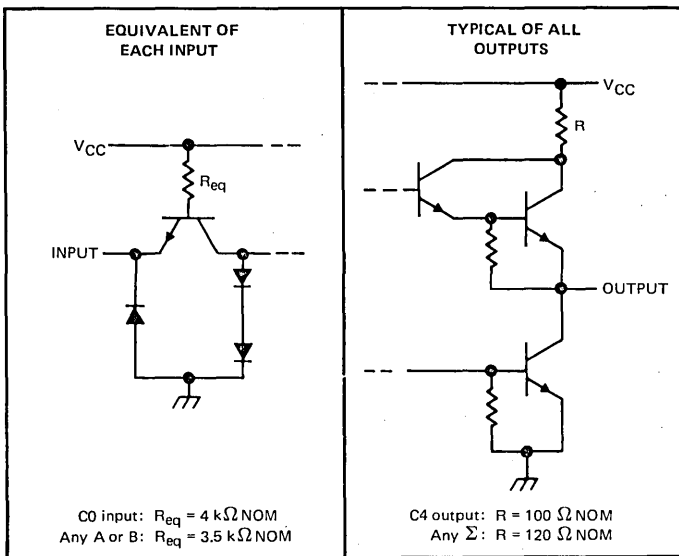

'LS83A

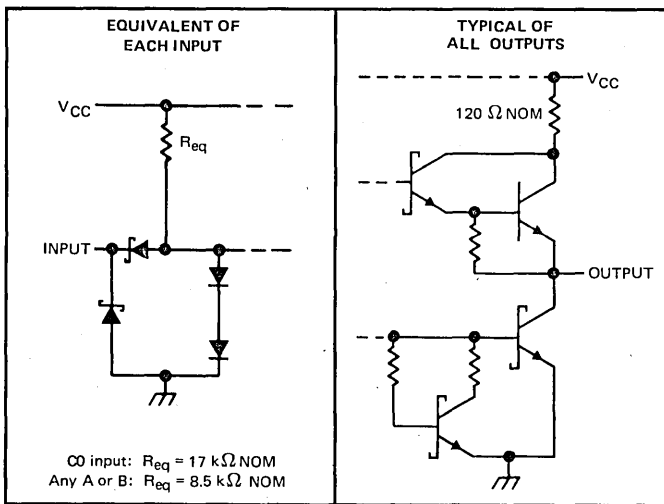

3

TTL DEVICES

TYPES SN5483A, SN54LS83A, SN7483A, SN74LS83A 4-BIT BINARY FULL ADDERS WITH FAST CARRY

logic diagram

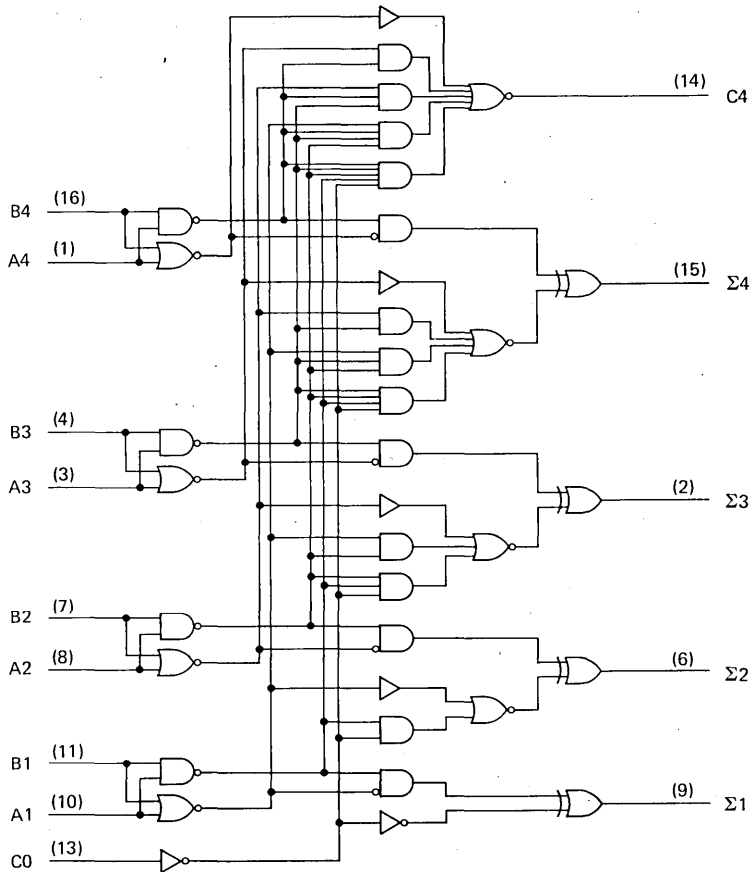

Pin numbers shown on logic notation are for D, J or N packages.

absolute maximum ratings over operating free-air temperature range (unless otherwise noted)

Supply voltage, V_{CC} (see Note 1)	7 V
Input voltage: '83A	5.5 V
'LS83A	7 V
Intermitter voltage (see Note 2)	5.5 V
Operating free-air temperature range: SN5483A, SN54LS83A	-55°C to 125°C
SN7483A, SN74LS83A	0°C to 70°C
Storage temperature range	-65°C to 150°C

- NOTES: 1. Voltage values, except intermitter voltage, are with respect to network ground terminal.
2. This is the voltage between two emitters of a multiple-emitter transistor. This rating applies for the '83A only between the following pairs: A1 and B1, A2 and B2, A3 and B3, A4 and B4.

3
TTL DEVICES

TYPES SN5483A, SN7483A

4-BIT BINARY FULL ADDERS WITH FAST CARRY

recommended operating conditions

		SN5483A			SN7483A			UNIT
		MIN	NOM	MAX	MIN	NOM	MAX	
Supply Voltage, V_{CC}		4.5	5	5.5	4.75	5	5.25	V
High-level output current, I_{OH}	Any output except C4	-800			-800			μ A
	Output C4	-400			-400			
Low-level output current, I_{OL}	Any output except C4	16			16			mA
	Output C4	8			8			
Operating free-air temperature, T_A		-55			125			$^{\circ}$ C

electrical characteristics over recommended operating free-air temperature range (unless otherwise noted)

PARAMETER		TEST CONDITIONS†	SN5483A			SN7483A			UNIT
			MIN	TYP‡	MAX	MIN	TYP‡	MAX	
V_{IH}	High-level input voltage		2			2			V
V_{IL}	Low-level input voltage		0.8			0.8			V
V_{IK}	Input clamp voltage	$V_{CC} = \text{MIN}, I_I = -12 \text{ mA}$	-1.5			-1.5			V
V_{OH}	High-level output voltage	$V_{CC} = \text{MIN}, V_{IH} = 2 \text{ V}, V_{IL} = 0.8 \text{ V}, I_{OH} = \text{MAX}$	2.4	3.4		2.4	3.4		V
V_{OL}	Low-level output voltage	$V_{CC} = \text{MIN}, V_{IH} = 2 \text{ V}, V_{IL} = 0.8 \text{ V}, I_{OL} = \text{MAX}$		0.2	0.4		0.2	0.4	V
I_I	Input current at maximum input voltage	$V_{CC} = \text{MAX}, V_I = 5.5 \text{ V}$	1			1			mA
I_{IH}	High-level input current	$V_{CC} = \text{MAX}, V_I = 2.4 \text{ V}$	40			40			μ A
I_{IL}	Low-level input current	$V_{CC} = \text{MAX}, V_I = 0.4 \text{ V}$	-1.6			-1.6			mA
I_{OS}	Short-circuit output current §	Any output except C4	-20			-18			mA
		Output C4	-20			-18			
I_{CC}	Supply current	$V_{CC} = \text{MAX},$ All B low, other inputs at 4.5 V	56			56			mA
		Outputs open	66	99		66	110		

† For conditions shown as MIN or MAX, use the appropriate value specified under recommended operating conditions.

‡ All typical values are at $V_{CC} = 5 \text{ V}, T_A = 25^{\circ} \text{C}$.

§ Only one output should be shorted at a time.

switching characteristics, $V_{CC} = 5 \text{ V}, T_A = 25^{\circ} \text{C}$

PARAMETER¶	FROM (INPUT)	TO (OUTPUT)	TEST CONDITIONS	MIN	TYP	MAX	UNIT
t_{PLH}	C0	Any Σ	$C_L = 15 \text{ pF}, R_L = 400 \Omega,$ See Note 3	14	21	ns	
t_{PHL}				12	21		
t_{PLH}	A_i or B_i	Σ_i		16	24	ns	
t_{PHL}				16	24		
t_{PLH}	C0	C4	$C_L = 15 \text{ pF}, R_L = 780 \Omega,$ See Note 3	9	14	ns	
t_{PHL}				11	16		
t_{PLH}	A_i or B_i	C4		9	14	ns	
t_{PHL}				11	16		

¶ t_{PLH} = Propagation delay time, low-to-high-level output

t_{PHL} = Propagation delay time, high-to-low-level output

NOTE 3: See General Information Section for load circuits and voltage waveforms.

TYPES SN54LS83A, SN74LS83A 4-BIT BINARY FULL ADDERS WITH FAST CARRY

recommended operating conditions

	SN54LS83A			SN74LS83A			UNIT
	MIN	NOM	MAX	MIN	NOM	MAX	
Supply voltage, V_{CC}	4.5	5	5.5	4.75	5	5.25	V
High-level output current, I_{OH}	-400			-400			μ A
Low-level output current, I_{OL}	4			8			mA
Operating free-air temperature, T_A	-55		125	0		70	$^{\circ}$ C

electrical characteristics over recommended operating free-air temperature range (unless otherwise noted)

PARAMETER		TEST CONDITIONS†	SN54LS83A		SN74LS83A		UNIT	
			MIN	TYP‡	MAX	MIN		TYP‡
V_{IH}	High-level input voltage		2		2		V	
V_{IL}	Low-level input voltage		0.7		0.8		V	
V_{IK}	Input clamp voltage	$V_{CC} = \text{MIN}, I_I = -18 \text{ mA}$	-1.5		-1.5		V	
V_{OH}	High-level output voltage	$V_{CC} = \text{MIN}, V_{IH} = 2 \text{ V}, V_{IL} = V_{IL \text{ max}}, I_{OH} = -400 \mu\text{A}$	2.5	3.4	2.7	3.4	V	
V_{OL}	Low-level output voltage	$V_{CC} = \text{MIN}, V_{IH} = 2 \text{ V}, V_{IL} = V_{IL \text{ max}}, I_{OL} = 4 \text{ mA}$ $I_{OL} = 8 \text{ mA}$	0.25	0.4	0.25	0.4	V	
I_I	Input current at maximum input voltage	Any A or B	0.2		0.2		mA	
		C0	0.1		0.1			
I_{IH}	High-level input current	$V_{CC} = \text{MAX}, V_I = 2.7 \text{ V}$	40		40		μ A	
			20		20			
I_{IL}	Low-level input current	$V_{CC} = \text{MAX}, V_I = 0.4 \text{ V}$	-0.8		-0.8		mA	
			-0.4		-0.4			
I_{OS}	Short-circuit output current‡	$V_{CC} = \text{MAX}$	-20	-100	-20	-100	mA	
I_{CC}	Supply current	$V_{CC} = \text{MAX},$ Outputs open	All inputs grounded	22	39	22	39	mA
			All B low, other inputs at 4.5 V	19	34	19	34	
			All inputs at 4.5 V	19	34	19	34	

† For conditions shown as MIN or MAX, use the appropriate value specified under recommended operating conditions.

‡ All typical values are at $V_{CC} = 5 \text{ V}, T_A = 25^{\circ}\text{C}$.

§ Only one output should be shorted at a time, and duration of the short-circuit should not exceed one second.

switching characteristics, $V_{CC} = 5 \text{ V}, T_A = 25^{\circ}\text{C}$

PARAMETER†	FROM (INPUT)	TO (OUTPUT)	TEST CONDITIONS		MIN	TYP	MAX	UNIT
t_{PLH}	C0	Any Σ	$C_L = 15 \text{ pF},$ See Note 4	$R_L = 2 \text{ k}\Omega,$		16	24	ns
t_{PHL}						15	24	
t_{PLH}	A_i or B_i	Σ_j				15	24	ns
t_{PHL}						15	24	
t_{PLH}	C0	C4				11	17	ns
t_{PHL}						15	22	
t_{PLH}	A_i or B_i	C4				11	17	ns
t_{PHL}						12	17	

† t_{PLH} = Propagation delay time, low-to-high-level output

t_{PHL} = Propagation delay time, high-to-low-level output

Note 4: See General Information Section for load circuits and voltage waveforms.

3

TTL DEVICES

TYPES SN5485, SN54L85, SN54LS85, SN54S85 SN7485, SN74LS85, SN74S85 4-BIT MAGNITUDE COMPARATORS

MARCH 1974 - REVISED DECEMBER 1983

TYPE	TYPICAL	TYPICAL
	POWER DISSIPATION	DELAY (4-BIT WORDS)
'85	275 mW	23 ns
'L85	20 mW	90 ns
'LS85	52 mW	24 ns
'S85	365 mW	11 ns

SN5485, SN54LS85, SN54S85 . . . J OR W PACKAGE
SN7485 . . . J OR N PACKAGE
SN74LS85, SN74S85 . . . D, J OR N PACKAGE
(TOP VIEW)

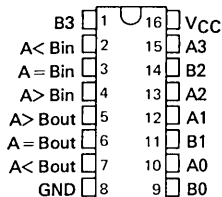

SN54L85 . . . J PACKAGE
(TOP VIEW)

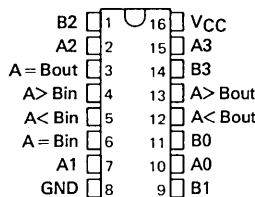

SN54LS85, SN54S85 . . . FK PACKAGE
SN74LS85, SN74S85 . . . FN PACKAGE
(TOP VIEW)

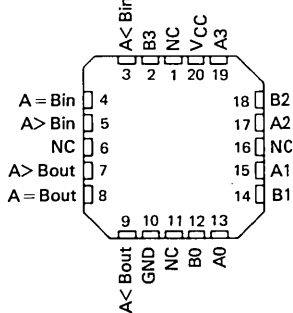

NC - No internal connection

description

These four-bit magnitude comparators perform comparison of straight binary and straight BCD (8-4-2-1) codes. Three fully decoded decisions about two 4-bit words (A, B) are made and are externally available at three outputs. These devices are fully expandable to any number of bits without external gates. Words of greater length may be compared by connecting comparators in cascade. The $A > B$, $A < B$, and $A = B$ outputs of a stage handling less-significant bits are connected to the corresponding $A > B$, $A < B$, and $A = B$ inputs of the next stage handling more-significant bits. The stage handling the least-significant bits must have a high-level voltage applied to the $A = B$ input and in addition for the 'L85, low-level voltages applied to the $A > B$ and $A < B$ inputs. The cascading paths of the '85, 'LS85, and 'S85 are implemented with only a two-gate-level delay to reduce overall comparison times for long words. An alternate method of cascading which further reduces the comparison time is shown in the typical application data.

FUNCTION TABLES

COMPARING INPUTS				CASCADING INPUTS			OUTPUTS		
A3, B3	A2, B2	A1, B1	A0, B0	A > B	A < B	A = B	A > B	A < B	A = B
A3 > B3	X	X	X	X	X	X	H	L	L
A3 < B3	X	X	X	X	X	X	L	H	L
A3 = B3	A2 > B2	X	X	X	X	X	H	L	L
A3 = B3	A2 < B2	X	X	X	X	X	L	H	L
A3 = B2	A2 = B2	A1 > B1	X	X	X	X	H	L	L
A3 = B3	A2 = B2	A1 < B1	X	X	X	X	L	H	L
A3 = B3	A2 = B2	A1 = B1	A0 > B0	X	X	X	H	L	L
A3 = B3	A2 = B2	A1 = B1	A0 < B0	X	X	X	L	H	L
A3 = B3	A2 = B2	A1 = B1	A0 = B0	H	L	L	H	L	L
A3 = B3	A2 = B2	A1 = B1	A0 = B0	L	H	L	L	H	L
A3 = B3	A2 = B2	A1 = B1	A0 = B0	L	L	H	L	L	H

'85, 'LS85, 'S85

A3 = B3	A2 = B2	A1 = B1	A0 = B0	X	X	H	L	L	H
A3 = B3	A2 = B2	A1 = B1	A0 = B0	H	H	L	L	L	L
A3 = B3	A2 = B2	A1 = B1	A0 = B0	L	L	L	H	H	L

'L85

A3 = B3	A2 = B2	A1 = B1	A0 = B0	L	H	H	L	H	H
A3 = B3	A2 = B2	A1 = B1	A0 = B0	H	L	H	H	L	H
A3 = B3	A2 = B2	A1 = B1	A0 = B0	H	H	H	H	H	H
A3 = B3	A2 = B2	A1 = B1	A0 = B0	H	H	L	H	H	L
A3 = B3	A2 = B2	A1 = B1	A0 = B0	L	L	L	L	L	L

H = high level, L = low level, X = irrelevant

PRODUCTION DATA

This document contains information current as of publication date. Products conform to specifications per the terms of Texas Instruments standard warranty. Production processing does not necessarily include testing of all parameters.

TEXAS
INSTRUMENTS

POST OFFICE BOX 225012 • DALLAS, TEXAS 75265

3

TTL DEVICES

**TYPES SN5485, SN54LS85, SN54S85,
SN7485, SN74LS85, SN74S85
4-BIT MAGNITUDE COMPARATORS**

logic diagrams

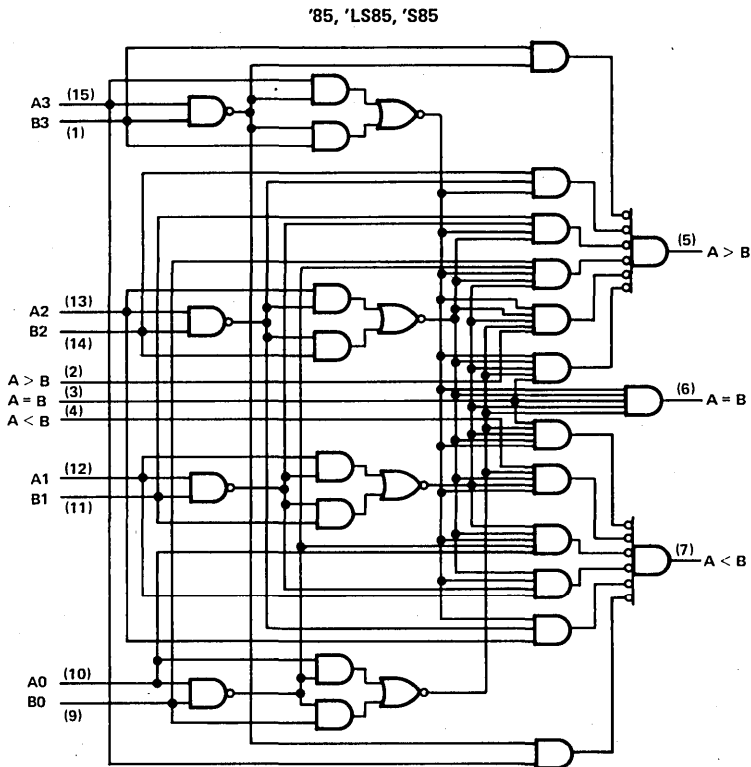

3

TTL DEVICES

TYPE SN54L85
4-BIT MAGNITUDE COMPARATOR

logic diagrams (continued)

'L85

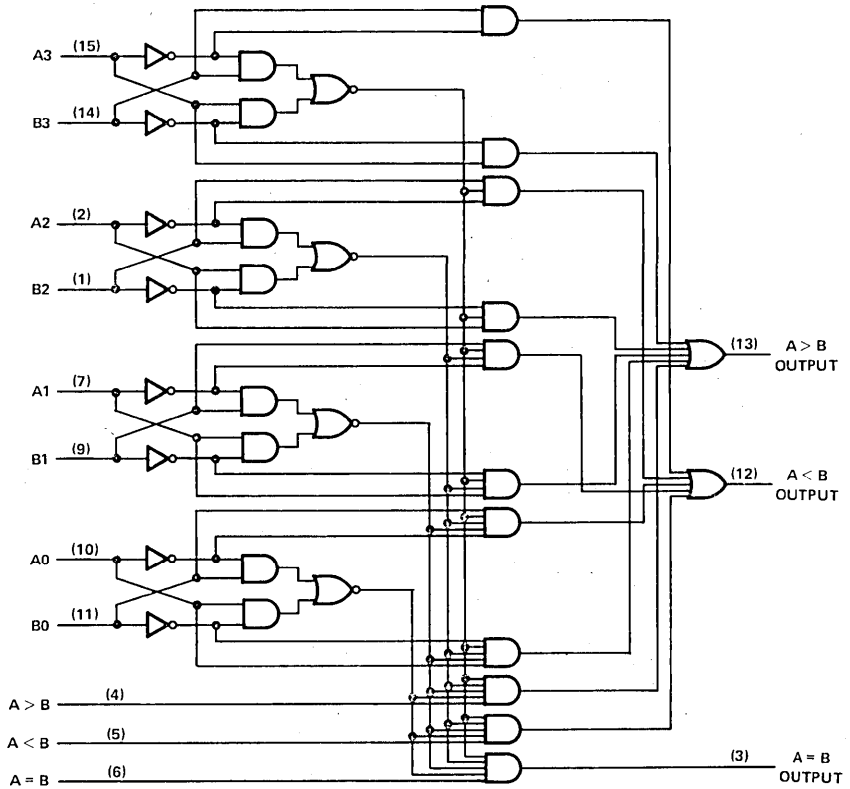

Pin numbers shown on logic notation are for D, J or N packages.



TTL DEVICES

TYPES SN5485, SN54L85, SN54LS85, SN54S85, SN7485, SN74LS85, SN74S85 4-BIT MAGNITUDE COMPARATORS

schematics of inputs and outputs

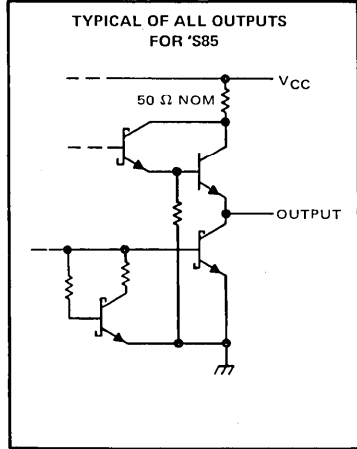
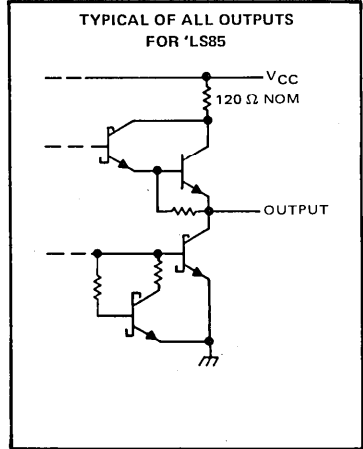
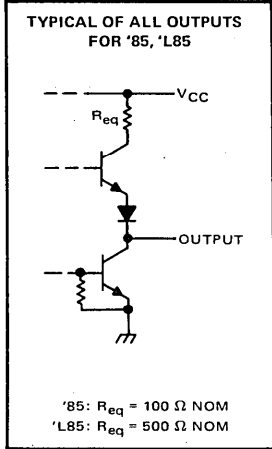
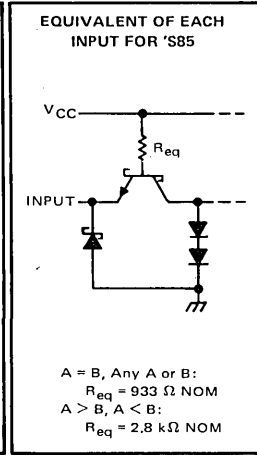
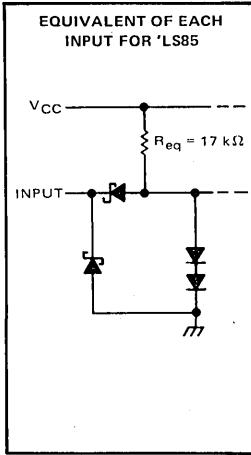
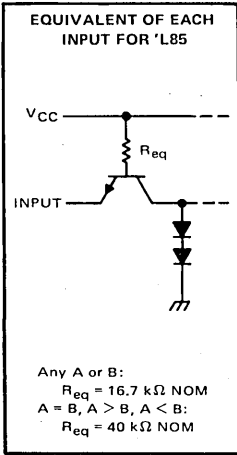
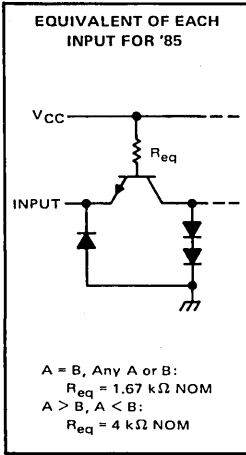

absolute maximum ratings over operating free-air temperature range (unless otherwise noted)

	SN54' SN54S'	SN54L'	SN54LS'	SN74' SN74S'	SN74LS'	UNIT
Supply voltage, V _{CC} (see Note 1)	7	8	7	7	7	V
Input voltage (see Note 2)	5.5	5.5	7	5.5	7	V
Intermitter voltage (see Note 3)	5.5			5.5		V
Operating free-air temperature range	- 55 to 125			- 0 to 70		°C
Storage temperature range	- 65 to 150			- 65 to 150		°C

NOTES: 1. Voltage values, except intermitter voltage, are with respect to network ground terminal.
2. Input voltages for 'L85 must be zero or positive with respect to network ground terminal.
3. This is the voltage between two emitters of a multiple-emitter input transistor. This rating applies to each A input in conjunction with its respective B input of the '85 and 'S85.

3 TTL DEVICES

TYPES SN5485, SN7485 4-BIT MAGNITUDE COMPARATORS

recommended operating conditions

	SN5485			SN7485			UNIT
	MIN	NOM	MAX	MIN	NOM	MAX	
Supply voltage, V_{CC}	4.5	5	5.5	4.75	5	5.25	V
High-level output current, I_{OH}	-400			-400			μ A
Low-level output current, I_{OL}	16			16			mA
Operating free-air temperature, T_A	-55			125			$^{\circ}$ C

electrical characteristics over recommended operating free-air temperature range (unless otherwise noted)

PARAMETER		TEST CONDITIONS†	MIN	TYP‡	MAX	UNIT
V_{IH}	High-level input voltage		2			V
V_{IL}	Low-level input voltage			0.8		V
V_{IK}	Input clamp voltage	$V_{CC} = \text{MIN}, I_I = -12 \text{ mA}$			-1.5	V
V_{OH}	High-level output voltage	$V_{CC} = \text{MIN}, V_{IL} = 0.8 \text{ V}, I_{OH} = -400 \mu\text{A}$	2.4	3.4		V
V_{OL}	Low-level output voltage	$V_{CC} = \text{MIN}, V_{IL} = 0.8 \text{ V}, I_{OL} = 16 \text{ mA}$		0.2	0.4	V
I_I	Input current at maximum input voltage	$V_{CC} = \text{MAX}, V_I = 5.5 \text{ V}$			1	mA
I_{IH}	High-level input current	A < B, A > B inputs	$V_{CC} = \text{MAX}, V_I = 2.4 \text{ V}$		40	μ A
		all other inputs			120	
I_{IL}	Low-level input current	A < B, A > B inputs	$V_{CC} = \text{MAX}, V_I = 0.4 \text{ V}$		-1.6	mA
		all other inputs			-4.8	
I_{OS}	Short-circuit output current§	$V_{CC} = \text{MAX}, V_O = 0$	SN5485	-20	-55	mA
I_{CC}	Supply current	$V_{CC} = \text{MAX},$ See Note 4	SN7485	-18	-55	mA
				55	88	

† For conditions shown as MIN or MAX, use the appropriate value specified under recommended operating conditions.

‡ All typical values are at $V_{CC} = 5 \text{ V}, T_A = 25^{\circ}\text{C}$.

§ Not more than one output should be shorted at a time.

NOTE 4: I_{CC} is measured with outputs open, A = B grounded, and all other inputs at 4.5 V.

switching characteristics, $V_{CC} = 5 \text{ V}, T_A = 25^{\circ}\text{C}$

PARAMETER¶	FROM INPUT	TO OUTPUT	NUMBER OF GATE LEVELS	TEST CONDITIONS	MIN	TYP	MAX	UNIT
t_{PLH}	Any A or B data input	A < B, A > B	1	$C_L = 15 \text{ pF},$ $R_L = 400 \Omega,$ See Note 5	7	ns		
			2		12			
		3	17		26			
		4	23		35			
t_{PHL}	Any A or B data input	A < B, A > B	1		11	ns		
			2		15			
		4	20		30			
t_{PLH}	A < B or A = B	A > B	1		7	11	ns	
			1	11	17	ns		
t_{PLH}	A = B	A = B	2	13	20	ns		
t_{PHL}	A = B	A = B	2	11	17	ns		
t_{PLH}	A > B or A = B	A < B	1	7	11	ns		
t_{PHL}	A > B or A = B	A < B	1	11	17	ns		

¶ t_{PLH} = propagation delay time, low-to-high-level output

t_{PHL} = propagation delay time, high-to-low-level output.

NOTE 5: See General Information Section for load circuits and voltage waveforms.

TYPE SN54L85 4-BIT MAGNITUDE COMPARATOR

recommended operating conditions

	SN54L85			UNIT
	MIN	NOM	MAX	
V _{CC} Supply voltage	4.5	5	5.5	V
V _{IH} High-level input voltage	2			V
V _{IL} Low-level input voltage				0.7
I _{OH} High-level output current				-0.1
I _{OL} Low-level output current				2
T _A Operating free-air temperature	-55	125		°C

electrical characteristics over recommended operating free-air temperature range (unless otherwise noted)

PARAMETER	TEST CONDITIONS [†]	SN54L85		UNIT
		MIN	TYP [‡]	
V _{OH}	V _{CC} = MIN, V _{IH} = 2 V, V _{IL} = 0.7 V, I _{OH} = -0.1 mA	2.4	3.3	V
V _{OL}	V _{CC} = MIN, V _{IH} = 2 V, V _{IL} = 0.7 V, I _{OL} = 2 mA	0.15		0.3
I _I	A < B, A > B, or A = B			0.1
	A or B inputs	V _{CC} = MAX, V _I = 5.5 V		0.3
I _{IH}	A < B, A > B, or A = B			10
	A or B inputs	V _{CC} = MAX, V _I = 2.4 V		30
I _{IL}	A < B, A > B, or A = B			-0.18
	A or B inputs	V _{CC} = MAX, V _I = 0.3 V		-0.54
I _{OS} [§]	V _{CC} = MAX	-3	-15	
I _{CC}	V _{CC} = MAX, See Note 6	Condition A		4.0
		Condition B		3.2
			7.2	7.2

[†] For conditions shown as MIN or MAX, use the appropriate value specified under recommended operating conditions

[‡] All typical values are at V_{CC} = 5 V, T_A = 25°C.

[§] Not more than one output should be shorted at a time.

NOTE 6: With all outputs open, I_{CC} is measured for Condition A with all inputs at 4.5 V, and for Condition B with all inputs grounded.

switching characteristics, V_{CC} = 5 V, T_A = 25°C (see note 5)

PARAMETER	FROM (INPUT)	TO (OUTPUT)	TEST CONDITIONS	MIN	TYP	MAX	UNIT
t _{PLH}	Any A or B	Any	R _L = 4 kΩ, C _L = 50 pF	90	150	ns	
t _{PHL}				75	150	ns	
t _{PLH}	A > B, A < B or A = B	75		150	ns		
t _{PHL}		55		100	ns		

NOTE 5: See General Information Section for load circuits and voltage waveforms.

3

TTL DEVICES

TYPES SN54LS85, SN74LS85 4-BIT MAGNITUDE COMPARATORS

recommended operating conditions

	SN54LS85			SN74LS85			UNIT
	MIN	NOM	MAX	MIN	NOM	MAX	
Supply voltage, V_{CC}	4.5	5	5.5	4.75	5	5.25	V
High-level output current, I_{OH}	-400			-400			μ A
Low-level output current, I_{OL}	4			8			mA
Operating free-air temperature, T_A	-55	125	0	70			$^{\circ}$ C

electrical characteristics over recommended operating free-air temperature range (unless otherwise noted)

PARAMETER		TEST CONDITIONS†	SN54LS85			SN74LS85			UNIT
			MIN	TYP‡	MAX	MIN	TYP‡	MAX	
V_{IH}	High-level input voltage		2			2			V
V_{IL}	Low-level input voltage		0.7			0.7			V
V_{IK}	Input clamp voltage	$V_{CC} = \text{MIN}, I_I = -18 \text{ mA}$	-1.5			-1.5			V
V_{OH}	High-level output voltage	$V_{CC} = \text{MIN}, V_{IH} = 2 \text{ V}, V_{IL} = V_{IL \text{ max}}, I_{OH} = -400 \mu\text{A}$	2.5	3.4		2.7	3.4		V
V_{OL}	Low-level output voltage	$V_{CC} = \text{MIN}, V_{IH} = 2 \text{ V}, V_{IL} = V_{IL \text{ max}}$	$I_{OL} = 4 \text{ mA}$		0.25		0.4		V
			$I_{OL} = 8 \text{ mA}$		0.35		0.5		
I_I	Input current at maximum input voltage	A < B, A > B inputs	$V_{CC} = \text{MAX}, V_I = 7 \text{ V}$			0.1			mA
		all other inputs				0.3			
I_{IH}	High-level input current	A < B, A > B inputs	$V_{CC} = \text{MAX}, V_I = 2.7 \text{ V}$			20			μ A
		all other inputs				60			
I_{IL}	Low-level input current	A < B, A > B inputs	$V_{CC} = \text{MAX}, V_I = 0.4 \text{ V}$			-0.4			mA
		all other inputs				-1.2			
I_{OS}	Short-circuit output current§	$V_{CC} = \text{MAX}$	-20	-100		-20	-100		mA
I_{CC}	Supply current	$V_{CC} = \text{MAX},$ See Note 4	10.4			20			mA

† For conditions shown as MIN or MAX, use the appropriate value specified under recommended operating conditions.

‡ All typical values are at $V_{CC} = 5 \text{ V}, T_A = 25^{\circ}\text{C}$.

§ Not more than one output should be shorted at a time, and duration of the short-circuit should not exceed one second.

NOTE 4: I_{CC} is measured with outputs open, A = B grounded, and all other inputs at 4.5 V.

switching characteristics, $V_{CC} = 5 \text{ V}, T_A = 25^{\circ}\text{C}$

PARAMETER¶	FROM INPUT	TO OUTPUT	NUMBER OF GATE LEVELS	TEST CONDITIONS	MIN	TYP	MAX	UNIT
t_{PLH}	Any A or B data input	A < B, A > B	1	$C_L = 15 \text{ pF}, R_L = 2 \text{ k}\Omega,$ See Note 5	14			ns
			2		19			
			3		24 36			
			4		27 45			
t_{PHL}	Any A or B data input	A < B, A > B	1		11			ns
			2		15			
			3		20 30			
			4		23 45			
t_{PLH}	A < B or A = B	A > B	1		14 22			ns
t_{PHL}	A < B or A = B	A > B	1		11 17			ns
t_{PLH}	A = B	A = B	2		13 20			ns
t_{PHL}	A = B	A = B	2		13 26			ns
t_{PLH}	A > B or A = B	A < B	1	14 22			ns	
t_{PHL}	A > B or A = B	A < B	1	11 17			ns	

¶ t_{PLH} = propagation delay time, low-to-high-level output

t_{PHL} = propagation delay time, high-to-low-level output

NOTE 5: See General Information Section for load circuits and voltage waveforms.

TYPES SN54S85, SN74S85

4-BIT MAGNITUDE COMPARATORS

recommended operating conditions

	SN54S85			SN74S85			UNIT
	MIN	NOM	MAX	MIN	NOM	MAX	
Supply voltage, V_{CC}	4.5	5	5.5	4.75	5	5.25	V
High-level output current, I_{OH}			-1			-1	mA
Low-level output current, I_{OL}			20			20	mA
Operating free-air temperature, T_A	-55		125	0		70	$^{\circ}$ C

electrical characteristics over recommended operating free-air temperature range (unless otherwise noted)

PARAMETER		TEST CONDITIONS†	MIN	TYP‡	MAX	UNIT	
V_{IH}	High-level input voltage		2			V	
V_{IL}	Low-level input voltage				0.8	V	
V_{IK}	Input clamp voltage	$V_{CC} = \text{MIN}, I_I = -18 \text{ mA}$			-1.2	V	
V_{OH}	High-level output voltage	$V_{CC} = \text{MIN}, V_{IH} = 2 \text{ V}, V_{IL} = 0.8 \text{ V}, I_{OH} = -1 \text{ mA}$	SN54S85 2.5	SN54S85 3.4	SN74S85 2.7	SN74S85 3.4	V
V_{OL}	Low-level output voltage	$V_{CC} = \text{MIN}, V_{IH} = 2 \text{ V}, V_{IL} = 0.8 \text{ V}, I_{OL} = 20 \text{ mA}$			0.5	V	
I_I	Input current at maximum input voltage	$V_{CC} = \text{MAX}, V_I = 5.5 \text{ V}$			1	mA	
I_{IH}	High-level input current	A < B, A > B inputs all other inputs	$V_{CC} = \text{MAX}, V_I = 2.7 \text{ V}$		50	μ A	
I_{IL}	Low-level input current	A < B, A > B inputs all other inputs	$V_{CC} = \text{MAX}, V_I = 0.5 \text{ V}$		-2	mA	
I_{OS}	Short-circuit output current§	$-V_{CC} = \text{MAX}$	-40		-100	mA	
I_{CC}	Supply current	$V_{CC} = \text{MAX}$, See Note 4 $V_{CC} = \text{MAX}, T_A = 125^{\circ}\text{C}$, See Note 4		73	115	mA	
		SN54S85W			110	mA	

† For conditions shown as MIN or MAX, use the appropriate value specified under recommended operating conditions.

‡ All typical values are at $V_{CC} = 5 \text{ V}, T_A = 25^{\circ}\text{C}$.

§ Not more than one output should be shorted at a time, and duration of the short-circuit should not exceed one second.

NOTE 4: I_{CC} is measured with outputs open, A = B grounded, and all other inputs at 4.5 V.

switching characteristics, $V_{CC} = 5 \text{ V}, T_A = 25^{\circ}\text{C}$

PARAMETER†	FROM INPUT	TO OUTPUT	NUMBER OF GATE LEVELS	TEST CONDITIONS	MIN	TYP	MAX	UNIT
t_{PLH}	Any A or B data input	A < B, A > B	1	$C_L = 15 \text{ pF}, R_L = 280 \Omega,$ See Note 5		5		ns
			2		7.5			
		3	10.5		16			
		4	12		18			
t_{PHL}	Any A or B data input	A < B, A > B	1		5.5			ns
			2		7			
		3	11		16.5			
		A = B	4		11	16.5		
t_{PLH}	A < B or A = B	A > B	1			5	7.5	ns
t_{PHL}	A < B or A = B	A > B	1			5.5	8.5	ns
t_{PLH}	A = B	A = B	2		7	10.5	ns	
t_{PHL}	A = B	A = B	2		5	7.5	ns	
t_{PLH}	A > B or A = B	A < B	1		5	7.5	ns	
t_{PHL}	A > B or A = B	A < B	1		5.5	8.5	ns	

† t_{PLH} = propagation delay time, low-to-high-level output

t_{PHL} = propagation delay time, high-to-low-level output

NOTE 5: See General Information Section for load circuits and voltage waveforms.

3

TTL DEVICES

TYPES SN5485, SN54L85, SN54LS85, SN54S85, SN7485, SN74LS85, SN74S85 4-BIT MAGNITUDE COMPARATORS

TYPICAL APPLICATION DATA

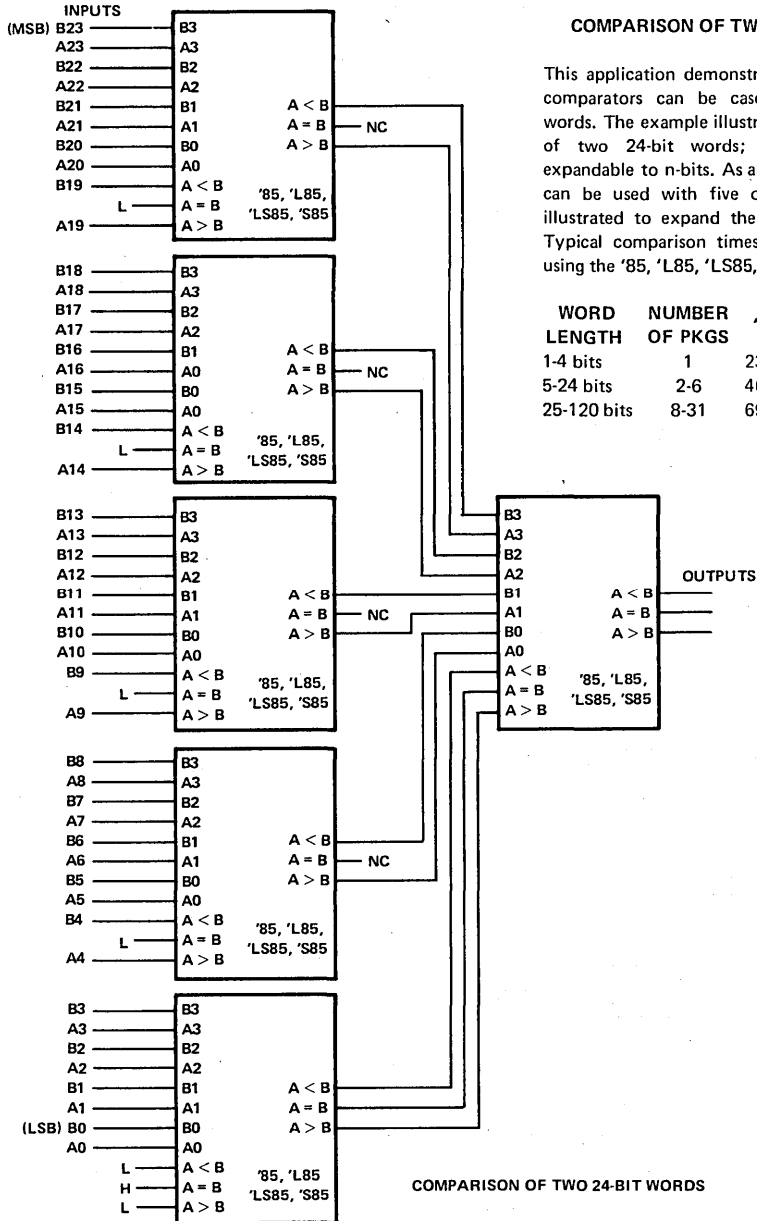



TTL DEVICES

TYPES SN5486, SN54LS86, SN54LS86A, SN54S86, SN7486, SN74LS86A, SN74S86

QUADRUPLE 2-INPUT EXCLUSIVE-OR GATES

DECEMBER 1972—REVISED DECEMBER 1983

schematics of inputs and outputs

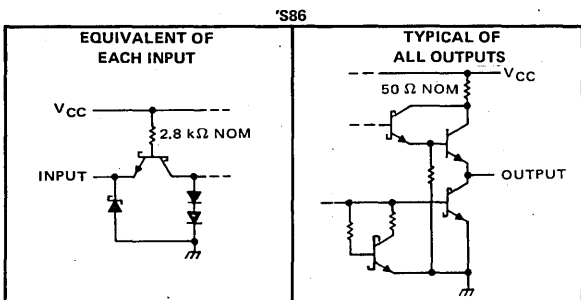
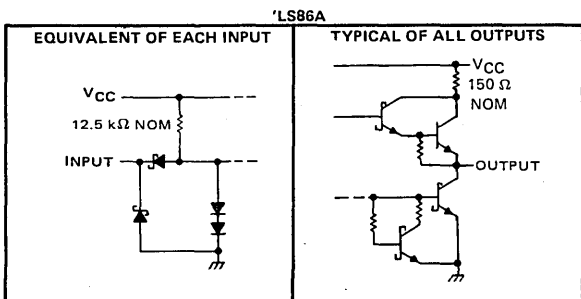
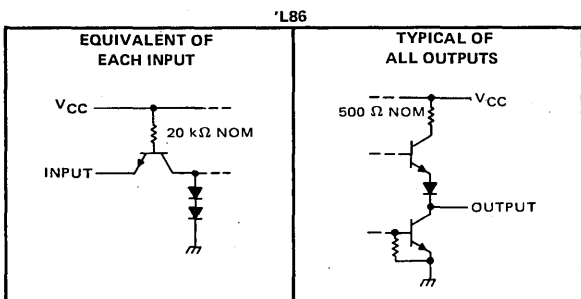
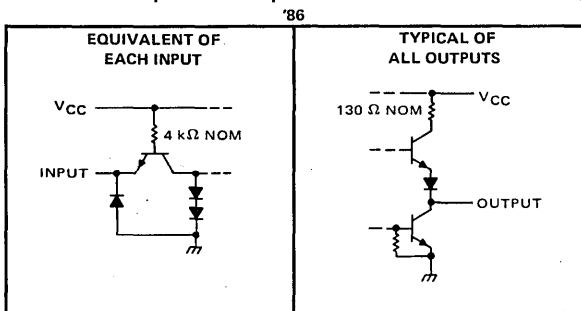

SN5486, SN54LS86A, SN54S86 ... J OR W PACKAGE

SN7486 ... J OR N PACKAGE

SN74LS86A, SN74S86 ... D, J OR N PACKAGE

(TOP VIEW)

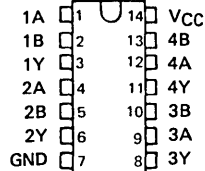

SN54L86 ... J PACKAGE

(TOP VIEW)

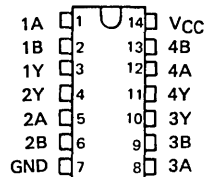

SN54LS86A, SN54S86 ... FK PACKAGE

SN74LS86A, SN74S86 ... FN PACKAGE

(TOP VIEW)

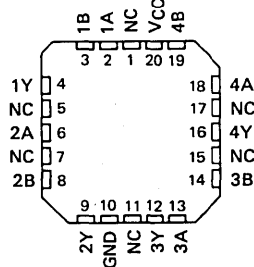

NC - No internal connection

FUNCTION TABLES

INPUTS		OUTPUT
A	B	Y
L	L	L
L	H	H
H	L	H
H	H	L

H = high level, L = low level

TYPE	TYPICAL AVERAGE PROPAGATION DELAY TIME	TYPICAL TOTAL POWER DISSIPATION
'86	14 ns	150 mW
'L86	55 ns	15 mW
'LS86A	10 ns	30.5 mW
'S86	7 ns	250 mW

PRODUCTION DATA
This document contains information current as of publication date. Products conform to specifications per the terms of Texas Instruments standard warranty. Production processing does not necessarily include testing of all parameters.

TEXAS INSTRUMENTS

POST OFFICE BOX 225012 • DALLAS, TEXAS 75265

TYPES SN5486, SN7486

QUADRUPLE 2-INPUT EXCLUSIVE-OR GATES

absolute maximum ratings over operating free-air temperature range (unless otherwise noted)

Supply voltage, V_{CC} (see Note 1)	7 V
Input voltage	5.5 V
Operating free-air temperature range: SN5486	-55°C to 125°C
SN7486	0°C to 70°C
Storage temperature range	-65°C to 150°C

NOTE 1: Voltage values are with respect to network ground terminal.

recommended operating conditions

	SN5486			SN7486			UNIT
	MIN	NOM	MAX	MIN	NOM	MAX	
Supply voltage, V_{CC}	4.5	5	5.5	4.75	5	5.25	V
High-level output current, I_{OH}			-800			-800	μ A
Low-level output current, I_{OL}			16			16	mA
Operating free-air temperature, T_A	-55		125	0		70	°C

electrical characteristics over recommended operating free-air temperature range (unless otherwise noted)

PARAMETER	TEST CONDITIONS [†]	SN5486			SN7486			UNIT
		MIN	TYP [‡]	MAX	MIN	TYP [‡]	MAX	
V_{IH} High-level input voltage		2			2			V
V_{IL} Low-level input voltage				0.8			0.8	V
V_{IK} Input clamp voltage	$V_{CC} = \text{MIN}, I_I = -8 \text{ mA}$			-1.5			-1.5	V
V_{OH} High-level output voltage	$V_{CC} = \text{MIN}, V_{IH} = 2 \text{ V}, V_{IL} = 0.8 \text{ V}, I_{OH} = -800 \mu\text{A}$	2.4	3.4		2.4	3.4		V
V_{OL} Low-level output voltage	$V_{CC} = \text{MIN}, V_{IH} = 2 \text{ V}, V_{IL} = 0.8 \text{ V}, I_{OL} = 16 \text{ mA}$		0.2	0.4		0.2	0.4	V
I_I Input current at maximum input voltage	$V_{CC} = \text{MAX}, V_I = 5.5 \text{ V}$			1			1	mA
I_{IH} High-level input current	$V_{CC} = \text{MAX}, V_I = 2.4 \text{ V}$			40			40	μ A
I_{IL} Low-level input current	$V_{CC} = \text{MAX}, V_I = 0.4 \text{ V}$			-1.6			-1.6	mA
I_{OS} Short-circuit output current [§]	$V_{CC} = \text{MAX}$	-20		-55	-18		-55	mA
I_{CC} Supply current	$V_{CC} = \text{MAX}, \text{ See Note 2}$		30	43		30	50	mA

[†]For conditions shown as MIN or MAX, use the appropriate value specified under recommended operating conditions for the applicable type.

[‡]All typical values are at $V_{CC} = 5 \text{ V}, T_A = 25^\circ \text{C}$.

[§]Not more than one output should be shorted at a time.

NOTE 2: I_{CC} is measured with the inputs grounded and the outputs open.

switching characteristics, $V_{CC} = 5 \text{ V}, T_A = 25^\circ \text{C}$

PARAMETER [¶]	FROM (INPUT)	TEST CONDITIONS			MIN	TYP	MAX	UNIT
t_{PLH}	A or B	Other input low	$C_L = 15 \text{ pF}, R_L = 400 \Omega,$ See Note 3		15	23	ns	
t_{PHL}					11	17		
t_{PLH}	A or B	Other input high	See Note 3		18	30	ns	
t_{PHL}					13	22		

[¶] t_{PLH} = propagation delay time, low-to-high-level output

t_{PHL} = propagation delay time, high-to-low-level output

NOTE 3: See General Information Section for load circuits and voltage waveforms.

TYPES SN54L86 QUADRUPLE 2-INPUT EXCLUSIVE-OR GATES

absolute maximum ratings over operating free-air temperature range (unless otherwise noted)

Supply voltage, V_{CC} (see Note 1)	7 V
Input voltage (see Note 4)	5.5 V
Operating free-air temperature range SN54L86	-55°C to 125°C
Storage temperature range	-65°C to 150°C

NOTES: 1. Voltage values are with respect to network ground terminal.
4. Input voltages must be zero or positive with respect to network ground terminal.

recommended operating conditions

	MIN	NOM	MAX	UNIT
V_{CC} Supply voltage	4.5	5	5.5	V
V_{IH} High-level input voltage	2			V
V_{IL} Low-level input voltage			0.7	V
I_{OH} High-level output current			-0.1	mA
I_{OL} Low-level output current			2	mA
T_A Operating free-air temperature	-55		125	°C

electrical characteristics over recommended operating free-air temperature range (unless otherwise noted)

PARAMETER	TEST CONDITIONS†	MIN	TYP	MAX	UNIT
V_{OH}	$V_{CC} = \text{MIN}$, $V_{IH} = 2 \text{ V}$, $V_{IL} = 0.7 \text{ V}$, $I_{OH} = -0.1 \text{ mA}$	2.4	3.3		V
V_{OL}	$V_{CC} = \text{MIN}$, $V_{IH} = 2 \text{ V}$, $V_{IL} = 0.7 \text{ V}$, $I_{OL} = 2 \text{ mA}$		0.15	0.3	V
I_I	$V_{CC} = \text{MAX}$, $V_I = 5.5 \text{ V}$			0.2	mA
I_{IH}	$V_{CC} = \text{MAX}$, $V_I = 2.4 \text{ V}$			20	μA
I_{IL}	$V_{CC} = \text{MAX}$, $V_I = 0.3 \text{ V}$			-0.36	mA
I_{OS}	$V_{CC} = \text{MAX}$	-3		-15	mA
I_{CCH}	$V_{CC} = \text{MAX}$, See Note 5		2.2	4.4	mA
I_{CCL}	$V_{CC} = \text{MAX}$, See Note 6		3.8	6.68	mA

† For conditions shown as MIN or MAX, use the appropriate value specified under recommended operating conditions.
‡ All typical values are at $V_{CC} = 5 \text{ V}$, $T_A = 25^\circ\text{C}$.

NOTES: 5. I_{CCH} is measured with all outputs open, one input of each gate at 4.5 V, and the other inputs grounded.
6. I_{CCL} is measured with all outputs open and all inputs at 4.5 V.

switching characteristics, $V_{CC} = 5 \text{ V}$, $T_A = 25^\circ\text{C}$

PARAMETER‡	FROM (INPUT)	TEST CONDITIONS		MIN	TYP	MAX	UNIT
t_{PLH}	A or B	Other input low	$C_L = 50 \text{ pF}$, $R_L = 4 \text{ k}\Omega$, See Note 3	75	150		ns
t_{PHL}				60	150		
t_{PLH}	A or B	Other input high		50	90		ns
t_{PHL}				35	60		

† t_{PLH} = propagation delay time, low-to-high-level output

‡ t_{PHL} = propagation delay time, high-to-low-level output

NOTE 3: See General Information Section for load circuits and voltage waveforms.

3
TTL DEVICES

TYPES SN54LS86A, SN74LS86A QUADRUPLE 2-INPUT EXCLUSIVE-OR GATES

absolute maximum ratings over operating free-air temperature range (unless otherwise noted)

Supply voltage, V_{CC} (see Note 1)	7 V
Input voltage	7 V
Operating free-air temperature range: SN54LS86A	-55°C to 125°C
SN74LS86A	0°C to 70°C
Storage temperature range	-65°C to 150°C

NOTE 1: Voltage values are with respect to network ground terminal.

recommended operating conditions

	SN54LS86A			SN74LS86A			UNIT
	MIN	NOM	MAX	MIN	NOM	MAX	
Supply voltage, V_{CC}	4.5	5	5.5	4.75	5	5.25	V
High-level output current, I_{OH}	-400			-400			μ A
Low-level output current, I_{OL}	4			8			mA
Operating free-air temperature, T_A	-55	125		0	70		°C

electrical characteristics over recommended operating free-air temperature range (unless otherwise noted)

PARAMETER	TEST CONDITIONS†	SN54LS86A			SN74LS86A			UNIT
		MIN	TYP‡	MAX	MIN	TYP‡	MAX	
V_{IH} High-level input voltage		2			2			V
V_{IL} Low-level input voltage		0.7			0.8			V
V_{IK} Input clamp voltage	$V_{CC} = \text{MIN}, I_I = -18 \text{ mA}$	-1.5			-1.5			V
V_{OH} High-level output voltage	$V_{CC} = \text{MIN}, V_{IH} = 2 \text{ V}, V_{IL} = V_{IL \text{ max}}, I_{OH} = -400 \mu\text{A}$	2.5	3.4		2.7	3.4		V
V_{OL} Low-level output voltage	$V_{CC} = \text{MIN}, V_{IH} = 2 \text{ V}, V_{IL} = V_{IL \text{ max}}$	0.25 0.4			0.25 0.4			V
	$I_{OL} = 4 \text{ mA}$				0.35 0.5			
	$I_{OL} = 8 \text{ mA}$							
I_I Input current at maximum input voltage	$V_{CC} = \text{MAX}, V_I = 7 \text{ V}$	0.2			0.2			mA
I_{IH} High-level input current	$V_{CC} = \text{MAX}, V_I = 2.7 \text{ V}$	40			40			μ A
I_{IL} Low-level input current	$V_{CC} = \text{MAX}, V_I = 0.4 \text{ V}$	-0.8			-0.8			mA
I_{OS} Short-circuit output current§	$V_{CC} = \text{MAX}$	-20	-100		-20	-100		mA
I_{CC} Supply current	$V_{CC} = \text{MAX},$ See Note 2	6.1 10		6.1 10		10		mA

†For conditions shown as MIN or MAX, use the appropriate value specified under recommended operating conditions for the applicable type.

‡All typical values are at $V_{CC} = 5 \text{ V}, T_A = 25^\circ\text{C}$.

§Not more than one output should be shorted at a time.

NOTE 2: I_{CC} is measured with the inputs grounded and the outputs open.

switching characteristics, $V_{CC} = 5 \text{ V}, T_A = 25^\circ\text{C}$

PARAMETER¶	FROM (INPUT)	TEST CONDITIONS		MIN	TYP	MAX	UNIT
t_{PLH}	A or B	Other input low	$C_L = 15 \text{ pF}, R_L = 2 \text{ k}\Omega,$ See Note 3	12 23		ns	
t_{PHL}				10 17			
t_{PLH}	A or B	Other input high	See Note 3	20 30		ns	
t_{PHL}				13 22			

¶ t_{PLH} = propagation delay time, low-to-high-level output

t_{PHL} = propagation delay time, high-to-low-level output

NOTE 3: See General Information Section for load circuits and voltage waveforms.

3 TTL DEVICES

TYPES SN54S86, SN74S86 QUADRUPLE 2-INPUT EXCLUSIVE-OR GATES

absolute maximum ratings over operating free-air temperature range (unless otherwise noted)

Supply voltage, V_{CC} (see Note 1)	7 V	
Input voltage	5.5 V	
Operating free-air temperature range: SN54S86	-55°C to 125°C	
SN74S86	0°C to 70°C	
Storage temperature range	-65°C to 150°C	

NOTE 1: Voltage values are with respect to network ground terminal.

recommended operating conditions

	SN54S86			SN74S86			UNIT
	MIN	NOM	MAX	MIN	NOM	MAX	
Supply voltage, V_{CC}	4.5	5	5.5	4.75	5	5.25	V
High-level output current, I_{OH}			-1			-1	mA
Low-level output current, I_{OL}			20			20	mA
Operating free-air temperature, T_A	-55		125	0		70	°C

electrical characteristics over recommended operating free-air temperature range (unless otherwise noted)

PARAMETER	TEST CONDITIONS†	SN54S86			SN74S86			UNIT
		MIN	TYP‡	MAX	MIN	TYP‡	MAX	
V_{IH} High-level input voltage		2			2			V
V_{IL} Low-level input voltage				0.8			0.8	V
V_{IK} Input clamp voltage	$V_{CC} = \text{MIN}, I_I = -18 \text{ mA}$			-1.2			-1.2	V
V_{OH} High-level output voltage	$V_{CC} = \text{MIN}, V_{IH} = 2 \text{ V}, V_{IL} = 0.8 \text{ V}, I_{OH} = -1 \text{ mA}$	2.5	3.4		2.7	3.4		V
V_{OL} Low-level output voltage	$V_{CC} = \text{MIN}, V_{IH} = 2 \text{ V}, V_{IL} = 0.8 \text{ V}, I_{OL} = 20 \text{ mA}$			0.5			0.5	V
I_I Input current at maximum input voltage	$V_{CC} = \text{MAX}, V_I = 5.5 \text{ V}$			1			1	mA
I_{IH} High-level input current	$V_{CC} = \text{MAX}, V_I = 2.7 \text{ V}$			50			50	µA
I_{IL} Low-level input current	$V_{CC} = \text{MAX}, V_I = 0.5 \text{ V}$			-2			-2	mA
I_{OS} Short-circuit output current§	$V_{CC} = \text{MAX}$	-40		-100	-40		-100	mA
I_{CC} Supply current	$V_{CC} = \text{MAX},$ See Note 2		50	75		50	75	mA

† For conditions shown as MIN or MAX, use the appropriate value specified under recommended operating conditions for the applicable type.

‡ All typical values are at $V_{CC} = 5 \text{ V}, T_A = 25^\circ \text{C}$.

§ Not more than one output should be shorted at a time, and duration of the short-circuit should not exceed one second.

NOTE 2: I_{CC} is measured with the inputs grounded and the outputs open.

switching characteristics, $V_{CC} = 5 \text{ V}, T_A = 25^\circ \text{C}$

PARAMETER¶	FROM (INPUT)	TEST CONDITIONS		MIN	TYP	MAX	UNIT
		Other input low	Other input high				
t_{PLH}	A or B	Other input low	$C_L = 15 \text{ pF}, R_L = 280 \Omega,$ See Note 3		7	10.5	ns
t_{PHL}				6.5	10		
t_{PLH}	A or B	Other input high	See Note 3		7	10.5	ns
t_{PHL}				6.5	10		

¶ t_{PLH} = propagation delay time, low-to-high-level output

t_{PHL} = propagation delay time, high-to-low-level output

NOTE 3: See General Information Section for load circuits and voltage waveforms.

3

TTL DEVICES

TYPES SN54H87, SN74H87 4-BIT TRUE/COMPLEMENT, ZERO/ONE ELEMENTS

DECEMBER 1972 REVISED DECEMBER 1983

description

Operation of these monolithic 4-bit true/complement elements is controlled by the B and C inputs. With the B input low, the 4-bit binary input (A) is transferred to the output (Y) in either complementary form (with C low) or true form (with C high). When the B input is high, the output will be at the complementary level of the C input regardless of the levels of the data inputs.

These circuits are fully compatible for use with other TTL circuits. Input clamping diodes are provided to minimize transmission line effects and thereby simplify system design. Each input represents only one normalized series 54H/74H load, and full fan-out to 10 series 54H/74H loads is available from each of the outputs in the low-level condition.

Power dissipation is 270 mW typically with an average propagation delay of 14 ns from data inputs to output.

The SN54H87 is characterized for operation over the full military temperature range of 55°C to 125°C, and the SN74H87 is characterized for operation from 0°C to 70°C.

SN54H87 . . . J OR W PACKAGE
SN74H87 . . . J OR N PACKAGE
(TOP VIEW)

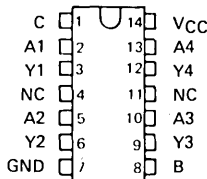

NC No internal connection

FUNCTION TABLE

CONTROL INPUTS		OUTPUTS			
B	C	Y1	Y2	Y3	Y4
L	L	A1	A2	A3	A4
L	H	A1	A2	A3	A4
H	L	H	H	H	H
H	H	L	L	L	L

H - high level, L - low level
A1, A2, A3, A4 - the level of the respective A input.

3

TTL DEVICES

absolute maximum ratings over operating free-air temperature range (unless otherwise noted)

Supply voltage, V_{CC} (see Note 1)	7 V
Input voltage	5.5 V
Operating free-air temperature range: SN54H87 Circuits	-55°C to 125°C
SN74H87 Circuits	0°C to 70°C
Storage temperature range	-65°C to 150°C

NOTE 1: Voltage values are with respect to network ground terminal.

recommended operating conditions

	SN54H87			SN74H87			UNIT
	MIN	NOM	MAX	MIN	NOM	MAX	
Supply voltage, V_{CC}	4.5	5	5.5	4.75	5	5.25	V
High-level output current, I_{OH}			1			-1	mA
Low-level output current, I_{OL}			20			20	mA
Operating free-air temperature, T_A	55		125	0		70	°C

PRODUCTION DATA

This document contains information current as of publication date. Products conform to specifications per the terms of Texas Instruments standard warranty. Production processing does not necessarily include testing of all parameters.

3-354

TEXAS
INSTRUMENTS

POST OFFICE BOX 225012 • DALLAS, TEXAS 75265

TYPES SN54H87, SN74H87 4-BIT TRUE/COMPLEMENT, ZERO/ONE ELEMENTS

electrical characteristics over recommended operating free-air temperature range (unless otherwise noted)

PARAMETER	TEST CONDITIONS [†]	MIN	TYP [‡]	MAX	UNIT
V _{IH} High-level input voltage		2			V
V _{IL} Low-level input voltage				0.8	V
V _{IK} Input clamp voltage	V _{CC} = MIN, I _I = -8 mA			-1.5	V
V _{OH} High-level output voltage	V _{CC} = MIN, V _{IH} = 2 V, V _{IL} = 0.8 V, I _{OH} = -1 mA	2.4	3.5		V
V _{OL} Low-level output voltage	V _{CC} = MIN, V _{IH} = 2 V, V _{IL} = 0.8 V, I _{OL} = 20 mA		0.2	0.4	V
I _I Input current at maximum input voltage	V _{CC} = MAX, V _I = 5.5 V			1	mA
I _{IH} High-level input current	V _{CC} = MAX, V _I = 2.4 V			50	μA
I _{IL} Low-level input current	V _{CC} = MAX, V _I = 0.4 V			-2	mA
I _{OS} Short-circuit output current [§]	V _{CC} = MAX	-40		-100	mA
I _{CC} Supply current	V _{CC} = MAX		54	78	mA
	See Note 2		54	89	

[†]For conditions shown as MIN or MAX, use the appropriate value specified under recommended operating conditions for the applicable type.

[‡]All typical values are at V_{CC} = 5 V, T_A = 25°C.

[§]Not more than one output should be shorted at a time and duration of the short-circuit should not exceed 1 second.

NOTE 2: I_{CC} is measured for the following conditions:

- a. All A inputs are at 4.5 V, B and C inputs are grounded, and all outputs are open.
- b. B and C inputs are at 4.5 V, all A inputs are grounded, and all outputs are open.

switching characteristics, V_{CC} = 5 V, T_A = 25°C

PARAMETER	TEST CONDITIONS	MIN	TYP	MAX	MAX
t _{PLH} Propagation delay time, low-to-high-level output from any A input	C _L = 25 pF, R _L = 280 Ω, See Note 3		14	20	ns
t _{PHL} Propagation delay time, high-to-low-level output from any A input			13	19	ns
t _{PLH} Propagation delay time, low-to-high-level output from B or C inputs			17	25	ns
t _{PHL} Propagation delay time, high-to-low-level output from B or C inputs			17	25	ns

NOTE 3: See General Information Section for load circuits and voltage waveforms.

logic diagram

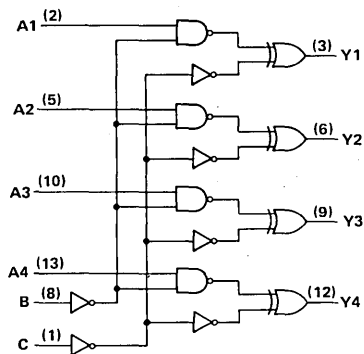

Pin numbers shown on logic notation are for J or N packages.

schematics of inputs and outputs

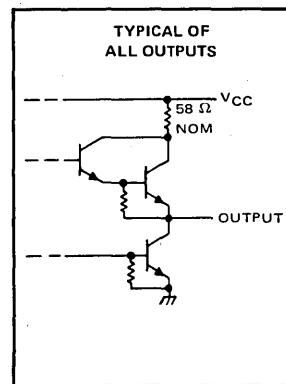
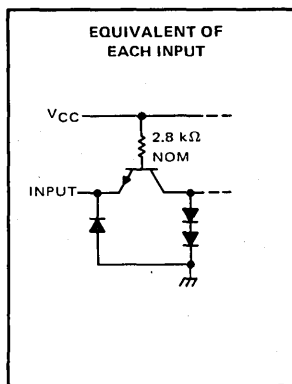

TTL DEVICES 3

3

TTL DEVICES

TYPES SN5490A, SN5492A, SN5493A, SN54L90, SN54L93, SN54LS90, SN54LS92, SN54LS93, SN7490A, SN7492A, SN7493A, SN74LS90, SN74LS92, SN74LS93 DECADE, DIVIDE-BY-TWELVE, AND BINARY COUNTERS

MARCH 1974 — REVISED DECEMBER 1983

'90A, 'L90, 'LS90 . . . DECADE COUNTERS

'92A, 'LS92 . . . DIVIDE-BY-TWELVE COUNTERS

'93A, 'L93, 'LS93 . . . 4-BIT BINARY COUNTERS

TYPES	TYPICAL POWER DISSIPATION
'90A	145 mW
'L90	20 mW
'LS90	45 mW
'92A, '93A	130 mW
'LS92, 'LS93	45 mW
'L93	16 mW

description

Each of these monolithic counters contains four master-slave flip-flops and additional gating to provide a divide-by-two counter and a three-stage binary counter for which the count cycle length is divide-by-five for the '90A, 'L90, and 'LS90, divide-by-six for the '92A and 'LS92, and divide-by-eight for the '93A, 'L93, and 'LS93.

All of these counters have a gated zero reset and the '90A, 'L90, and 'LS90 also have gated set-to-nine inputs for use in BCD nine's complement applications.

To use their maximum count length (decade, divide-by-twelve, or four-bit binary) of these counters, the CKB input is connected to the Q_A output. The input count pulses are applied to CKA input and the outputs are as described in the appropriate function table. A symmetrical divide-by-ten count can be obtained from the '90A, 'L90, or 'LS90 counters by connecting the Q_D output to the CKA input and applying the input count to the CKB input which gives a divide-by-ten square wave at output Q_A .

SN5490A, SN54LS90 . . . J OR W PACKAGE
SN54L90 . . . J PACKAGE
SN7490A . . . J OR N PACKAGE
SN74LS90 . . . D, J OR N PACKAGE
(TOP VIEW)

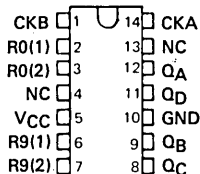

SN5492A, SN54LS92 . . . J OR W PACKAGE
SN7492A . . . J OR N PACKAGE
SN74LS92 . . . D, J OR N PACKAGE
(TOP VIEW)

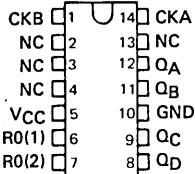

SN5493A, SN54LS93 . . . J OR W PACKAGE
SN7493A . . . J OR N PACKAGE
SN74LS93 . . . D, J OR N PACKAGE
(TOP VIEW)

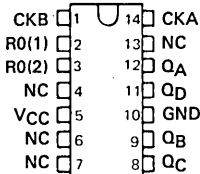

SN54L93 . . . J PACKAGE
(TOP VIEW)

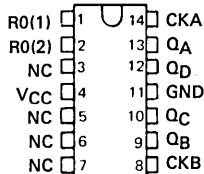

NC - No internal connection

For new chip carrier design, use 'LS290, 'LS292, and 'LS293.

PRODUCTION DATA
This document contains information current as of publication date. Products conform to specifications per the terms of Texas Instruments standard warranty. Production processing does not necessarily include testing of all parameters.

**TEXAS
INSTRUMENTS**

POST OFFICE BOX 225012 • DALLAS, TEXAS 75265

3

TTL DEVICES

**TYPES SN5490A, '92A, '93A, SN54L90, 'L93, SN54LS90, 'LS92, 'LS93,
SN7490A, '92A, '93A, SN74LS90, 'LS92, 'LS93
DECADE, DIVIDE-BY-TWELVE, AND BINARY COUNTERS**

**'90A, 'L90, 'LS90
BCD COUNT SEQUENCE
(See Note A)**

COUNT	OUTPUT			
	Q _D	Q _C	Q _B	Q _A
0	L	L	L	L
1	L	L	L	H
2	L	L	H	L
3	L	L	H	H
4	L	H	L	L
5	L	H	L	H
6	L	H	H	L
7	L	H	H	H
8	H	L	L	L
9	H	L	L	H

**'90A, 'L90, 'LS90
BI-QUINARY (5-2)
(See Note B)**

COUNT	OUTPUT			
	Q _A	Q _D	Q _C	Q _B
0	L	L	L	L
1	L	L	L	H
2	L	L	H	L
3	L	L	H	H
4	L	H	L	L
5	H	L	L	L
6	H	L	L	H
7	H	L	H	L
8	H	L	H	H
9	H	H	L	L

**'92A, 'LS92
COUNT SEQUENCE
(See Note C)**

COUNT	OUTPUT			
	Q _D	Q _C	Q _B	Q _A
0	L	L	L	L
1	L	L	L	H
2	L	L	H	L
3	L	L	H	H
4	L	H	L	L
5	L	H	L	H
6	H	L	L	L
7	H	L	L	H
8	H	L	H	L
9	H	L	H	H
10	H	H	L	L
11	H	H	L	H

**'90A, 'L90, 'LS90
RESET/COUNT FUNCTION TABLE**

RESET INPUTS				OUTPUT			
R ₀ (1)	R ₀ (2)	R ₉ (1)	R ₉ (2)	Q _D	Q _C	Q _B	Q _A
H	H	L	X	L	L	L	L
H	H	X	L	L	L	L	L
X	X	H	H	H	L	L	H
X	L	X	L	COUNT			
L	X	L	X	COUNT			
L	X	X	L	COUNT			
X	L	L	X	COUNT			

**'93A, 'L93, 'LS93
COUNT SEQUENCE
(See Note C)**

COUNT	OUTPUT			
	Q _D	Q _C	Q _B	Q _A
0	L	L	L	L
1	L	L	L	H
2	L	L	H	L
3	L	L	H	H
4	L	H	L	L
5	L	H	L	H
6	L	H	H	L
7	L	H	H	H
8	H	L	L	L
9	H	L	L	H
10	H	L	H	L
11	H	L	H	H
12	H	H	L	L
13	H	H	L	H
14	H	H	H	L
15	H	H	H	H

**'92A, 'LS92, '93A, 'L93, 'LS93
RESET/COUNT FUNCTION TABLE**

RESET INPUTS		OUTPUT			
R ₀ (1)	R ₀ (2)	Q _D	Q _C	Q _B	Q _A
H	H	L	L	L	L
L	X	COUNT			
X	L	COUNT			

- NOTES: A. Output Q_A is connected to input CKB for BCD count.
 B. Output Q_D is connected to input CKA for bi-quinary count.
 C. Output Q_A is connected to input CKB.
 D. H = high level, L = low level, X = irrelevant

TYPES SN5490A, '92A, '93A, SN54L90, 'L93, SN54LS90, 'LS92, 'LS93 SN7490A, '92A, '93A, SN74LS90, 'LS92, 'LS93 DECADE, DIVIDE-BY-TWELVE, AND BINARY COUNTERS

logic diagrams

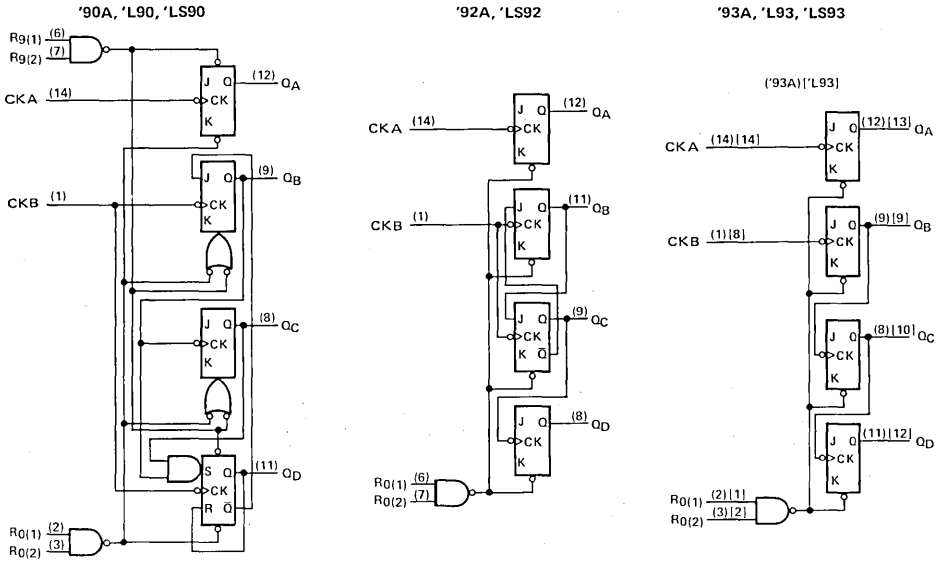

The J and K inputs shown without connection are for reference only and are functionally at a high level. Pin numbers shown in () are for the 'LS93 and '93A and pin numbers shown in [] are for the 54L93.

schematics of inputs and outputs

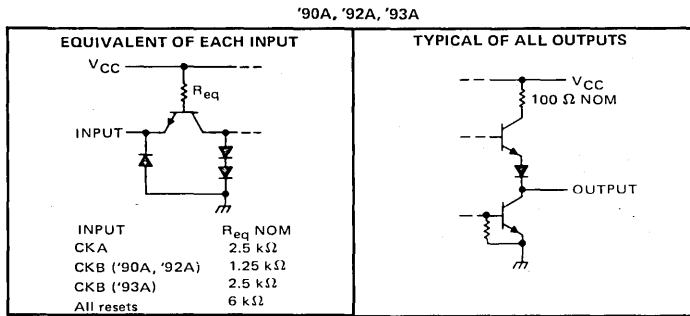

3

TTL DEVICES

**TYPES SN54L90, 'L93, SN54LS90, 'LS92, 'LS93
SN74LS90, 'LS92, 'LS93
DECADE, DIVIDE-BY-TWELVE, AND BINARY COUNTERS**

schematics of inputs and outputs (continued)

'L90, 'L93

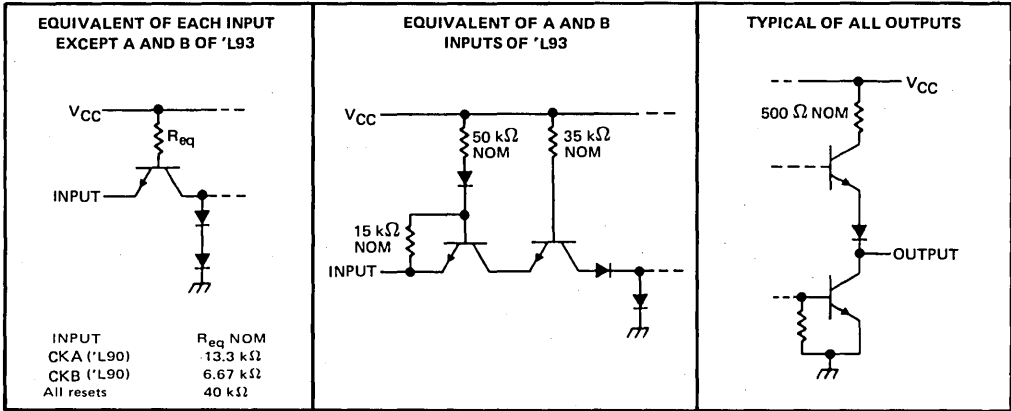

'LS90, 'LS92, 'LS93

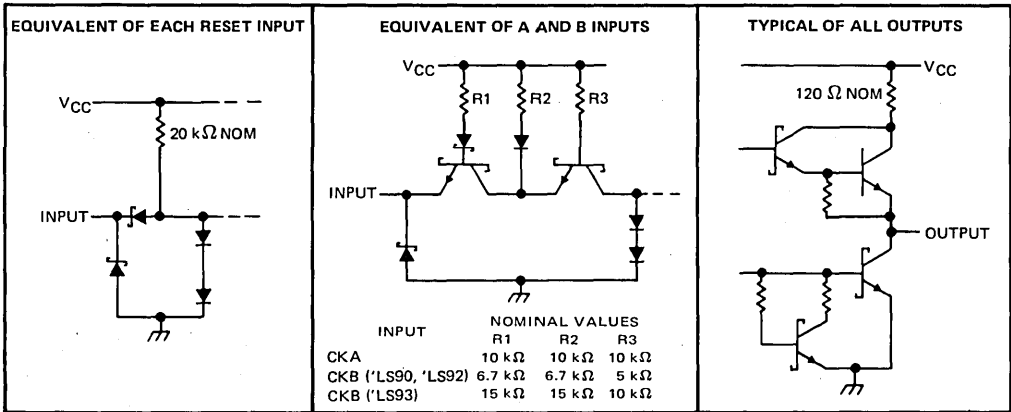

3 TTL DEVICES

TYPES SN5490A, SN5492A, SN5493A, SN7490A, SN7492A, SN7493A DECADE, DIVIDE-BY-TWELVE, AND BINARY COUNTERS

absolute maximum ratings over operating free-air temperature range (unless otherwise noted)

Supply voltage, V_{CC} (see Note 1)	7 V
Input voltage	5.5 V
Intermitter voltage (see Note 2)	5.5 V
Operating free-air temperature range: SN5490A, SN5492A, SN5493A	-55°C to 125°C
SN7490A, SN7492A, SN7493A	0°C to 70°C
Storage temperature range	-65°C to 150°C

- NOTES: 1. Voltage values, except intermitter voltage, are with respect to network ground terminal.
 2. This is the voltage between two emitters of a multiple emitter transistor. For these circuits, this rating applies between the two R_0 inputs, and for the '90A circuit, it also applies between the two R_0 inputs.

recommended operating conditions

	SN5490A, SN5492A SN5493A			SN7490A, SN7492A SN7493A			UNIT
	MIN	NOM	MAX	MIN	NOM	MAX	
Supply voltage, V_{CC}	4.5	5	5.5	4.75	5	5.25	V
High-level output current, I_{OH}				-800			μ A
Low-level output current, I_{OL}				16			mA
Count frequency, f_{count} (see Figure 1)	A input	0	32	0	32		MHz
	B input	0	16	0	16		
Pulse width, t_w	A input	15		15			ns
	B input	30		30			
	Reset inputs	15		15			
Reset inactive-state setup time, t_{SU}				25			ns
Operating free-air temperature, T_A	-55	125		0	70		°C

electrical characteristics over recommended operating free-air temperature range (unless otherwise noted)

PARAMETER [¶]	TEST CONDITIONS [†]	'90A		'92A		'93A		UNIT		
		MIN	TYP [‡]	MAX	MIN	TYP [‡]	MAX		MIN	TYP [‡]
V_{IH}	High-level input voltage	2		2		2		V		
V_{IL}	Low-level input voltage	0.8		0.8		0.8		V		
V_{IK}	Input clamp voltage	$V_{CC} = \text{MIN}, I_I = -12 \text{ mA}$		-1.5		-1.5		V		
V_{OH}	High-level output voltage	$V_{CC} = \text{MIN}, V_{IH} = 2 \text{ V}, V_{IL} = 0.8 \text{ V}, I_{OH} = -800 \mu\text{A}$		2.4	3.4	2.4	3.4	V		
V_{OL}	Low-level output voltage	$V_{CC} = \text{MIN}, V_{IH} = 2 \text{ V}, V_{IL} = 0.8 \text{ V}, I_{OL} = 16 \text{ mA}^{\S}$		0.2	0.4	0.2	0.4	V		
I_I	Input current at maximum input voltage	$V_{CC} = \text{MAX}, V_I = 5.5 \text{ V}$		1		1		mA		
I_{IH}	High-level input current	Any reset	40		40		40		μ A	
		CKA	80		80		80			
		CKB	120		120		80			
I_{IL}	Low-level input current	Any reset	-1.6		-1.6		-1.6		mA	
		CKA	-3.2		-3.2		-3.2			
		CKB	-4.8		-4.8		-3.2			
I_{OS}	Short-circuit output current [§]	$V_{CC} = \text{MAX}$	SN54 [¶]	-20	-57	-20	-57	-20	-57	mA
			SN74 [¶]	-18	-57	-18	-57	-18	-57	
I_{CC}	Supply current	$V_{CC} = \text{MAX}, \text{ See Note 3}$		29	42	26	39	26	39	mA

[†] For conditions shown as MIN or MAX, use the appropriate value specified under recommended operating conditions.

[‡] All typical values are at $V_{CC} = 5 \text{ V}, T_A = 25^\circ \text{C}$.

[§] Not more than one output should be shorted at a time.

[¶] I_{OH} outputs are tested at $I_{OL} = 16 \text{ mA}$ plus the limit value for I_{IL} for the CKB input. This permits driving the CKB input while maintaining full fan-out capability.

NOTE 3: I_{CC} is measured with all outputs open, both R_0 inputs grounded following momentary connection to 4.5 V, and all other inputs grounded.

3

TTL DEVICES

**TYPES SN5490A, SN5492A, SN5493A, SN7490A, SN7492A, SN7493A
DECADE, DIVIDE-BY-TWELVE, AND BINARY COUNTERS**

switching characteristics, $V_{CC} = 5\text{ V}$, $T_A = 25^\circ\text{C}$

PARAMETER [†]	FROM (INPUT)	TO (OUTPUT)	TEST CONDITIONS	'90A			'92A			'93A			UNIT
				MIN	TYP	MAX	MIN	TYP	MAX	MIN	TYP	MAX	
f_{max}	CKA	Q_A	$C_L = 15\text{ pF}$, $R_L = 400\ \Omega$, See Figure 1	32	42		32	42		32	42		MHz
	CKB	Q_B		16			16			16			
t_{PLH}	CKA	Q_A		10	16		10	16		10	16		ns
t_{PHL}				12	18		12	18		12	18		
t_{PLH}	CKA	Q_D		32	48		32	48		46	70		ns
t_{PHL}				34	50		34	50		46	70		
t_{PLH}	CKB	Q_B		10	16		10	16		10	16		ns
t_{PHL}				14	21		14	21		14	21		
t_{PLH}	CKB	Q_C		21	32		10	16		21	32		ns
t_{PHL}				23	35		14	21		23	35		
t_{PLH}	CKB	Q_D		21	32		21	32		34	51		ns
t_{PHL}				23	35		23	35		34	51		
t_{PHL}	Set-to-0	Any		26	40		26	40		26	40		ns
t_{PLH}	Set-to-9	Q_A, Q_D		20	30								ns
t_{PHL}		Q_B, Q_C		26	40								

[†] f_{max} = maximum count frequency
 t_{PLH} = propagation delay time, low-to-high-level output
 t_{PHL} = propagation delay time, high-to-low-level output

TYPES SN54L90, SN54L93 DECADE AND BINARY COUNTERS

absolute maximum ratings over operating free-air temperature range (unless otherwise noted)

Supply voltage, V_{CC} (see Note 1)	8 V
Input voltage (see Note 2)	5.5 V
Operating free-air temperature range:	-55°C to 125°C
Storage temperature range	-65°C to 150°C

- NOTES: 1. Voltage values are with respect to network ground terminal.
2. Input voltages must be zero or positive with respect to network ground terminal.

recommended operating conditions

		SN54L90, SN54L93			UNIT
		MIN	NOM	MAX	
V_{CC}	Supply voltage	4.5	5	5.5	V
f_{count}	Count frequency	0		3	MHz
I_{OH}	High-level output current			-0.1	mA
I_{OL}	Low-level output current			2	mA
$t_w(count)$	Width of input count pulse	200			ns
$t_w(reset)$	Width of reset pulse	200			ns
T_A	Operating free-air temperature	-55		125	°C

electrical characteristics over recommended operating free-air temperature range (unless otherwise noted)

PARAMETER	TEST CONDITIONS†	SN54L90		SN54L93		UNIT	
		MIN	TYP‡	MAX	MIN		TYP‡
V_{IH}	High-level input voltage	2		2		V	
V_{IL}	Low-level input voltage			0.7		V	
V_{OH}	High-level output voltage	$V_{CC} = \text{MIN}$, $V_{IL} = 0.7 \text{ V}$, $I_{OH} = \text{MAX}$	2.4	3.3	2.4	3.3	V
V_{OL}	Low-level output voltage	$V_{CC} = \text{MIN}$, $V_{IH} = 2 \text{ V}$, $V_{IL} = 0.7 \text{ V}$, $I_{OL} = \text{MAX}^\S$	0.15	0.3	0.15	0.3	V
I_I	Input current at maximum input voltage	Any reset input		100		100	μA
		CKA	$V_{CC} = \text{MAX}$, $V_I = 5.5 \text{ V}$	300		200	
		CKB		600		200	
I_{IH}	High-level input current	Any reset input		10		10	μA
		CKA	$V_{CC} = \text{MAX}$, $V_I = 2.4 \text{ V}$	30		20	
		CKB		60		20	
I_{IL}	Low-level input current	Any reset input		-0.18		-0.18	mA
		CKA	$V_{CC} = \text{MAX}$, $V_I = 0.3 \text{ V}$	-0.54		-0.36	
		CKB		-1.08		-0.36	
I_{OS}	Short-circuit output current §	$V_{CC} = \text{MAX}$	-3	-15	-3	-15	mA
I_{CC}	Supply current	$V_{CC} = \text{MAX}$, See Note 3	4	7.2	3.2	6.6	mA

†For conditions shown as MIN or MAX, use the appropriate value specified under recommended operating conditions.

‡All typical values are at $V_{CC} = 5 \text{ V}$, $T_A = 25^\circ\text{C}$.

§Not more than one output should be shorted at a time.

¶ I_{QA} outputs are tested at $I_{OL} = \text{MAX}$ plus the limit value for I_{IL} for the CKB input. This permits driving the CKB input while maintaining full fan-out capability.

NOTE 3: I_{CC} is measured with all outputs open, both R_D inputs grounded following momentary connection to 4.5 V, and all other inputs grounded.

switching characteristics, $V_{CC} = 5 \text{ V}$, $T_A = 25^\circ\text{C}$

PARAMETER	TEST CONDITIONS	SN54L90		SN54L93		UNIT	
		MIN	TYP	MAX	MIN		TYP
f_{max}	Maximum count frequency	3	6	3	6	MHz	
t_{PLH}	Propagation delay time, low-to-high-level Q_D output from input CKA	$C_L = 50 \text{ pF}$, See Figure 1	230	340	280	450	ns
t_{PHL}	Propagation delay time, high-to-low-level Q_D output from input CKB		230	340	280	450	ns

TYPES SN54LS90, SN54LS92, SN54LS93, SN74LS90, SN74LS92, SN74LS93 DECADE, DIVIDE-BY-TWELVE, AND BINARY COUNTERS

absolute maximum ratings over operating free-air temperature range (unless otherwise noted)

Supply voltage, V_{CC} (see Note 1)	7 V
Input voltage: R inputs	7 V
A and B inputs	5.5 V
Operating free-air temperature range: SN54LS' Circuits	-55°C to 125°C
SN74LS' Circuits	0°C to 70°C
Storage temperature range	-65°C to 150°C

NOTE 1: Voltage values are with respect to network ground terminal.

recommended operating conditions

		SN54LS90 SN54LS92 SN54LS93			SN74LS90 SN74LS92 SN74LS93			UNIT
		MIN	NOM	MAX	MIN	NOM	MAX	
Supply voltage, V_{CC}		4.5	5	5.5	4.75	5	5.25	V
High-level output current, I_{OH}				-400			-400	μ A
Low-level output current, I_{OL}				4			8	mA
Count frequency, f_{count} (see Figure 1)	A input	0		32	0		32	MHz
	B input	0		16	0		16	
Pulse width, t_w	A input	15			15			ns
	B input	30			30			
	Reset inputs	30			30			
Reset inactive-state setup time, t_{su}		25			25			ns
Operating free-air temperature, T_A		-55		125	0		70	°C

electrical characteristics over recommended operating free-air temperature range (unless otherwise noted)

PARAMETER	TEST CONDITIONS†	SN54LS90 SN54LS92			SN74LS90 SN74LS92			UNIT
		MIN	TYP‡	MAX	MIN	TYP‡	MAX	
V_{IH} High-level input voltage		2			2			V
V_{IL} Low-level input voltage				0.7			0.8	V
V_{IK} Input clamp voltage	$V_{CC} = \text{MIN}, I_I = -18 \text{ mA}$			-1.5			-1.5	V
V_{OH} High-level output voltage	$V_{CC} = \text{MIN}, V_{IH} = 2 \text{ V}, V_{IL} = V_{IL \text{ max}}, I_{OH} = -400 \mu\text{A}$	2.5	3.4		2.7	3.4		V
V_{OL} Low-level output voltage	$V_{CC} = \text{MIN}, V_{IH} = 2 \text{ V}, V_{IL} = V_{IL \text{ max}}, I_{OL} = 4 \text{ mA} \parallel$		0.25	0.4		0.25	0.4	V
	$I_{OL} = 8 \text{ mA} \parallel$					0.35	0.5	
I_I Input current at maximum input voltage	Any reset			0.1			0.1	mA
	CKA			0.2			0.2	
	CKB			0.4			0.4	
I_{IH} High-level input current	Any reset			20			20	μ A
	CKA			40			40	
	CKB			80			80	
I_{IL} Low-level input current	Any reset			-0.4			-0.4	mA
	CKA			-2.4			-2.4	
	CKB			-3.2			-3.2	
I_{OS} Short-circuit output current§	$V_{CC} = \text{MAX}$	-20		-100	-20		-100	mA
I_{CC} Supply current	$V_{CC} = \text{MAX},$ See Note 3	'LS90	9	15	9	15	15	mA
		'LS92	9	15	9	15		

† For conditions shown as MIN or MAX, use the appropriate value specified under recommended operating conditions.

‡ All typical values are at $V_{CC} = 5 \text{ V}, T_A = 25^\circ \text{C}$.

§ Not more than one output should be shorted at a time, and duration of the short-circuit should not exceed one second.

¶ I_{QA} outputs are tested at specified I_{OL} plus the limit value of I_{IL} for the CKB input. This permits driving the CKB input while maintaining full fan-out capability.

NOTE 3: I_{CC} is measured with all outputs open, both R_O inputs grounded following momentary connection to 4.5 V, and all other inputs grounded.

3 TTL DEVICES



POST OFFICE BOX 225012 • DALLAS, TEXAS 75265

TYPES SN54LS90, SN54LS92, SN54LS93, SN74LS90, SN74LS92, SN74LS93 DECADE, DIVIDE-BY-TWELVE, AND BINARY COUNTERS

electrical characteristics over recommended operating free-air temperature range (unless otherwise noted)

PARAMETER		TEST CONDITIONS†	SN54LS93			SN74LS93			UNIT		
			MIN	TYP‡	MAX	MIN	TYP‡	MAX			
V _{IH}	High-level input voltage		2				2		V		
V _{IL}	Low-level input voltage				0.7			0.8	V		
V _{IK}	Input clamp voltage	V _{CC} = MIN, I _I = -18 mA			-1.5			-1.5	V		
V _{OH}	High-level output voltage	V _{CC} = MIN, V _{IH} = 2 V, V _{IL} = V _{IL} max, I _{OH} = -400 μA	2.5	3.4		2.7	3.4		V		
V _{OL}	Low-level output voltage	V _{CC} = MIN, V _{IH} = 2 V, V _{IL} = V _{IL} max			0.25	0.4	0.25	0.4	V		
I _I	Input current at maximum input voltage	Any reset	V _{CC} = MAX, V _I = 7 V			0.1			0.1	mA	
		CKA or CKB	V _{CC} = MAX, V _I = 5.5 V			0.2			0.2		
I _{IH}	High-level input current	Any reset	V _{CC} = MAX, V _I = 2.7 V			20			20	μA	
		CKA or CKB				40			80		
I _{IL}	Low-level input current	Any reset				-0.4			-0.4	mA	
		CKA	V _{CC} = MAX, V _I = 0.4 V			-2.4			-2.4		
		CKB				-1.6			-1.6		
I _{OS}	Short-circuit output current§	V _{CC} = MAX	-20			-100			-20	-100	mA
I _{CC}	Supply current	V _{CC} = MAX, See Note 3	9			15			9	15	mA

† For conditions shown as MIN or MAX, use the appropriate value specified under recommended operating conditions.

‡ All typical values are at V_{CC} = 5 V, T_A = 25°C.

§ Not more than one output should be shorted at a time, and duration of the short-circuit should not exceed one second.

¶ Q_A outputs are tested at specified I_{OL} plus the limit value for I_{IL} for the CKB input. This permits driving the CKB input while maintaining full fan-out capability.

NOTE 3: I_{CC} is measured with all outputs open, both R_D inputs grounded following momentary connection to 4.5 V, and all other inputs grounded.

switching characteristics, V_{CC} = 5 V, T_A = 25°C

PARAMETER‡	FROM (INPUT)	TO (OUTPUT)	TEST CONDITIONS	'LS90			'LS92			'LS93			UNIT
				MIN	TYP	MAX	MIN	TYP	MAX	MIN	TYP	MAX	
f _{max}	CKA	Q _A	C _L = 15 pF, R _L = 2 kΩ See Figure 1	32	42		32	42		32	42		MHz
	CKB	Q _B		16			16			16			
t _{PLH}	CKA	Q _A		10	16		10	16		10	16		ns
t _{PHL}		Q _A		12	18		12	18		12	18		
t _{PLH}	CKA	Q _D		32	48		32	48		46	70		ns
t _{PHL}		Q _D		34	50		34	50		46	70		
t _{PLH}	CKB	Q _B		10	16		10	16		10	16		ns
t _{PHL}		Q _B		14	21		14	21		14	21		
t _{PLH}	CKB	Q _C		21	32		10	16		21	32		ns
t _{PHL}		Q _C		23	35		14	21		23	35		
t _{PLH}	CKB	Q _D		21	32		21	32		34	51		ns
t _{PHL}		Q _D		23	35		23	35		34	51		
t _{PHL}	Set-to-0	Any		26	40		26	40		26	40		ns
t _{PLH}	Set-to-9	Q _A , Q _D		20	30								ns
t _{PHL}		Q _B , Q _C	26	40									

‡ f_{max} = maximum count frequency

t_{PLH} = propagation delay time, low to high level output

t_{PHL} = propagation delay time, high to low level output



TTL DEVICES

PARAMETER MEASUREMENT INFORMATION

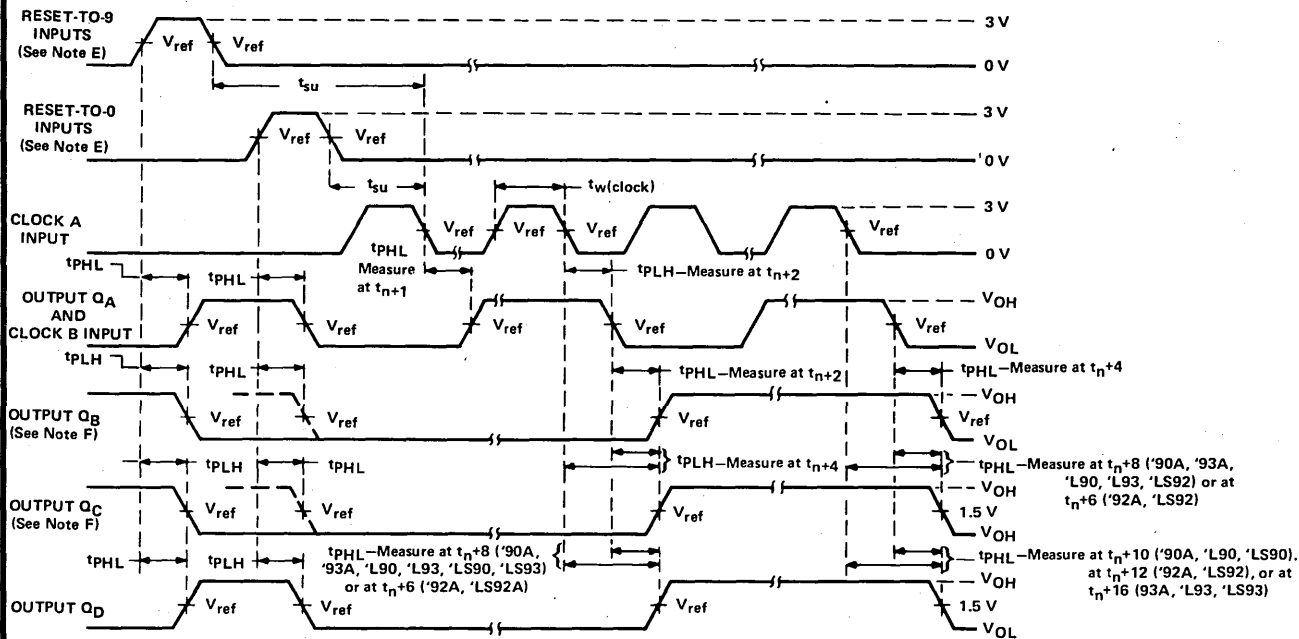

- NOTES: A. Input pulses are supplied by a generator having the following characteristics:
 for '90A, '92A, '93A, $t_r \leq 5$ ns, $t_f \leq 5$ ns, PRR = 1 MHz, duty cycle = 50%, $Z_{out} \approx 50$ ohms;
 for 'L90, 'L93, $t_r \leq 15$ ns, $t_f \leq 15$ ns, PRR = 500 kHz, duty cycle = 50%, $Z_{out} \approx 50$ ohms;
 for 'LS90, 'LS92, 'LS93, $t_r \leq 15$ ns, $t_f \leq 5$ ns, PRR = 1 MHz, duty cycle = 50%, $Z_{out} \approx 50$ ohms.
- B. C_L includes probe and jig capacitance.
- C. C1 (30 pF) is applicable for testing 'L90 and 'L93.
- D. All diodes are 1N3064 or equivalent.
- E. Each reset input is tested separately with the other reset at 4.5 V.
- F. Reference waveforms are shown with dashed lines.
- G. For '90A, '92A, and '93A; $V_{ref} = 1.5$ V. For 'L90, 'L93, 'LS90, 'LS92, and 'LS93; $V_{ref} = 1.3$ V.

FIGURE 1A

TYPES SN5490A, SN5492A, SN5493A, SN54L90, SN54L93, SN54LS90, SN54LS92,
 SN54LS93, SN7490A, SN7492A, SN7493A, SN74LS90, SN74LS92, SN74LS93
 DECADE, DIVIDE-BY-TWELVE, AND BINARY COUNTERS

PARAMETER MEASUREMENT INFORMATION

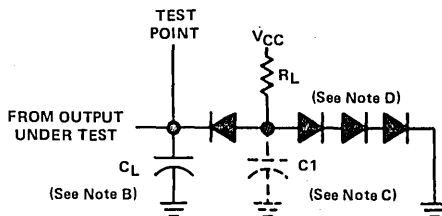

LOAD CIRCUIT

- NOTES: A. Input pulses are supplied by a generator having the following characteristics:
 for '90A, '92A, '93A, $t_r \leq 5$ ns, $t_f \leq 5$ ns, PRR = 1 MHz, duty cycle = 50%, $Z_{out} \approx 50$ ohms;
 for 'L90, 'L93, $t_r \leq 15$ ns, $t_f \leq 15$ ns, PRR = 500 kHz, duty cycle = 50%, $Z_{out} \approx 50$ ohms;
 for 'LS90, 'LS92, 'LS93, $t_r \leq 15$ ns, $t_f \leq 5$ ns, PRR = 1 MHz, duty cycle = 50%, $Z_{out} \approx 50$ ohms.
- B. C_L includes probe and jig capacitance.
- C. C_1 (30 pF) is applicable for testing 'L90 and 'L93.
- D. All diodes are 1N3064 or equivalent.
- E. Each reset input is tested separately with the other reset at 4.5 V.
- F. Reference waveforms are shown with dashed lines.
- G. For '90A, '92A, and '93A; $V_{ref} = 1.5$ V. For 'L90, 'L93, 'LS90, 'LS92, and 'LS93; $V_{ref} = 1.3$ V.

FIGURE 1B

3
 TTL DEVICES



TTL DEVICES

TYPES SN5491A, SN54L91, SN54LS91, SN7491A, SN74LS91 8-BIT SHIFT REGISTERS

MARCH 1974 — REVISED DECEMBER 1983

- For applications in:
Digital Computer Systems
Data-Handling Systems
Control Systems

SN5491A, SN54L91, SN54LS91 ... J PACKAGE
SN7491A ... J OR N PACKAGE
SN74LS91 ... D, J OR N PACKAGE
(TOP VIEW)

TYPE	TYPICAL MAXIMUM CLOCK FREQUENCY	TYPICAL POWER DISSIPATION
'91A	18 MHz	175 mW
'L91	6.5 MHz	17.5 mW
'LS91	18 MHz	60 mW

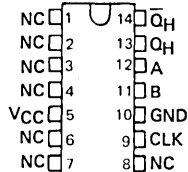

description

These monolithic serial-in, serial-out, 8-bit shift registers utilize transistor-transistor logic (TTL) circuits and are composed of eight R-S master-slave flip-flops, input gating, and a clock driver. Single-rail data and input control are gated through inputs A and B and an internal inverter to form the complementary inputs to the first bit of the shift register. Drive for the internal common clock line is provided by an inverting clock driver. This clock pulse inverter/driver causes these circuits to shift information one bit on the positive edge of an input clock pulse.

SN5491A, SN54LS91 ... W PACKAGE
(TOP VIEW)

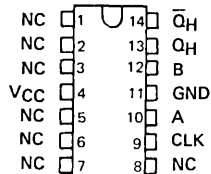

NC - No internal connection

schematics of inputs and outputs

FUNCTION TABLE

INPUTS AT t_n		OUTPUTS AT t_{n+8}	
A	B	$\overline{Q_H}$	Q_H
H	H	H	L
L	X	L	H
X	L	L	H

t_n = Reference bit time,
clock low
 t_{n+8} = Bit time after 8
low-to-high
clock transitions.

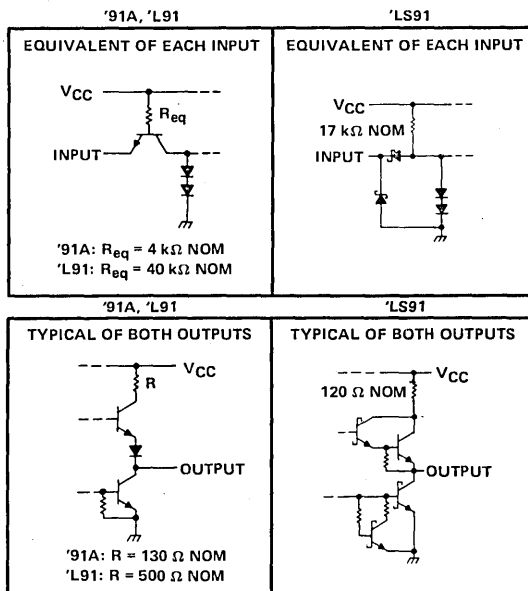

TTL DEVICES

PRODUCTION DATA

This document contains information current as of publication date. Products conform to specifications per the terms of Texas Instruments standard warranty. Production processing does not necessarily include testing of all parameters.



POST OFFICE BOX 225012 • DALLAS, TEXAS 75265

TYPES SN5491A, SN7491A 8-BIT SHIFT REGISTERS

logic diagram

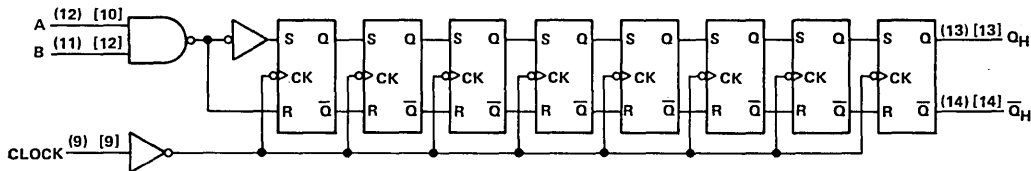

Pin numbers shown in () are for the D, J or N packages and pin numbers shown in [] are for the W package.

absolute maximum ratings over operating free-air temperature range (unless otherwise noted)

Supply voltage, V_{CC} (see Note 1)	7 V
Input voltage (see Note 2)	5.5 V
Operating free-air temperature range: SN5491A	-55°C to 125°C
SN7491A	0°C to 70°C
Storage temperature range	-65°C to 150°C

NOTES: 1. Voltage values are with respect to network ground terminal.
2. Input signals must be zero or positive with respect to network ground terminal.

recommended operating conditions

	SN5491A			SN7491A			UNIT
	MIN	NOM	MAX	MIN	NOM	MAX	
Supply voltage, V_{CC}	4.5	5	5.5	4.75	5	5.25	V
High-level output current, I_{OH}	-400			-400			μ A
Low-level output current, I_{OL}	16			16			mA
Width of clock input pulse, t_w	25			25			ns
Setup time, t_{su} (see Figure 1)	25			25			ns
Hold time, t_h (see Figure 1)	0			0			ns
Operating free-air temperature, T_A	-55			125			0
				70			°C

electrical characteristics over recommended operating free-air temperature range (unless otherwise noted)

PARAMETER	TEST CONDITIONS†	SN5491A			SN7491A			UNIT
		MIN	NOM	MAX	MIN	NOM	MAX	
V_{IH} High-level input voltage		2			2			V
V_{IL} Low-level input voltage		0.8			0.8			V
V_{OH} High-level output voltage	$V_{CC} = \text{MIN}$, $V_{IH} = 2 \text{ V}$, $V_{IL} = 0.8 \text{ V}$, $I_{OH} = -400 \mu\text{A}$	2.4	3.5		2.4	3.5		V
V_{OL} Low-level output voltage	$V_{CC} = \text{MIN}$, $V_{IH} = 2 \text{ V}$, $V_{IL} = 0.8 \text{ V}$, $I_{OL} = 16 \text{ mA}$	0.2		0.4	0.2	0.4		V
I_I Input current at maximum input voltage	$V_{CC} = \text{MAX}$, $V_I = 5.5 \text{ V}$	1			1			mA
I_{IH} High-level input current	$V_{CC} = \text{MAX}$, $V_I = 2.4 \text{ V}$	40			40			μ A
I_{IL} Low-level input current	$V_{CC} = \text{MAX}$, $V_I = 0.4 \text{ V}$	-1.6			-1.6			mA
I_{OS} Short-circuit output current‡	$V_{CC} = \text{MAX}$	-20	-57		-18	-57		mA
I_{CC} Supply current	$V_{CC} = \text{MAX}$, See Note 3	35		50	35	58		mA

† For conditions shown as MIN or MAX, use the appropriate value specified under recommended operating conditions.

‡ All typical values are at $V_{CC} = 5 \text{ V}$, $T_A = 25^\circ\text{C}$.

§ Not more than one output should be shorted at a time.

NOTE 3: I_{CC} is measured after the eighth clock pulse with the output open and A and B inputs grounded.

switching characteristics, $V_{CC} = 5 \text{ V}$, $T_A = 25^\circ\text{C}$

PARAMETER	TEST CONDITIONS	MIN	TYP	MAX	UNIT
f_{max} Maximum clock frequency	$C_L = 15 \text{ pF}$,	10	18		MHz
t_{PLH} Propagation delay time, low-to-high-level output	$R_L = 400 \Omega$,		24	40	ns
t_{PHL} Propagation delay time, high-to-low-level output	See Figure 1		27	40	ns

absolute maximum ratings over operating free-air temperature range (unless otherwise noted)

Supply voltage, V_{CC} (see Note 1)	8 V
Input voltage (see Note 2)	5.5 V
Operating free-air temperature range	-55°C to 125°C
Storage temperature range	-65°C to 150°C

NOTES: 1. Voltage values are with respect to network ground terminal.
2. Input signals must be zero or positive with respect to network ground terminal.

recommended operating conditions

		SN54L91			UNIT
		MIN	NOM	MAX	
V_{CC}	Supply voltage	4.5	5	5.5	V
V_{IH}	High-level input voltage	2			V
V_{IL}	Low-level input voltage	0.7			V
I_{OH}	High-level output current	-0.1			mA
I_{OL}	Low-level output current	2			mA
$t_w(\text{clock})$	Width of clock input pulse	High logic level		100	ns
		Low logic level		150	ns
t_{su}	Setup time (See Figure 1)	120			ns
t_h	Hold time (See Figure 1)	0			ns
T_A	Operating free-air temperature	-55	125		°C

electrical characteristics over recommended operating free-air temperature range (unless otherwise noted)

PARAMETER	TEST CONDITIONS †	SN54L91			UNIT
		MIN	TYP‡	MAX	
V_{OH}	$V_{CC} = \text{MIN}$, $V_{IH} = 2 \text{ V}$, $V_{IL} = 0.7 \text{ V}$, $I_{OH} = -0.1 \text{ mA}$	2.4	3.3		V
V_{OL}	$V_{CC} = \text{MIN}$, $V_{IH} = 2 \text{ V}$, $V_{IL} = 0.7 \text{ V}$, $I_{OL} = 2 \text{ mA}$	0.15	0.3		V
I_I	$V_{CC} = \text{MAX}$, $V_I = 5.5 \text{ V}$			0.1	mA
I_{IH}	$V_{CC} = \text{MAX}$, $V_I = 2.4 \text{ V}$			10	µA
I_{IL}	$V_{CC} = \text{MAX}$, $V_I = 0.3 \text{ V}$			-0.18	mA
I_{OS}	$V_{CC} = \text{MAX}$	-3		-15	mA
I_{CC}	$V_{CC} = \text{MAX}$, See Note 3		3.5	6.6	mA

† For conditions shown as MIN or MAX, use the appropriate value specified under recommended operating conditions.

‡ All typical values are at $V_{CC} = 5 \text{ V}$, $T_A = 25^\circ\text{C}$.

NOTE 3: I_{CC} is measured after the eighth clock pulse with the outputs open and A and B inputs grounded.

switching characteristics, $V_{CC} = 5 \text{ V}$, $T_A = 25^\circ\text{C}$ (see note 4)

PARAMETER	FROM (INPUT)	TO (OUTPUT)	TEST CONDITIONS	MIN	TYP	MAX	UNIT	
f_{max}	Any	Q_H, \bar{Q}_h	$R_L = 4 \text{ k}\Omega$, $C_L = 50 \text{ pF}$	3	6.5		MHz	
t_{PLH}					55	100		ns
t_{PHL}					100	150		ns

NOTE 4: For load circuits and voltage waveforms, see Figure 1.

TTL DEVICES 3

TYPES SN54LS91, SN74LS91 8-BIT SHIFT REGISTERS

absolute maximum ratings over operating free-air temperature range (unless otherwise noted)

Supply voltage, V_{CC} (see Note 1)	7 V
Input voltage	7 V
Operating free-air temperature range: SN54LS91	-55°C to 125°C
SN74LS91	0°C to 70°C
Storage temperature range	-65°C to 150°C

NOTES: 1. Voltage values are with respect to network ground terminal.

recommended operating conditions

	SN54LS91			SN74LS91			UNIT
	MIN	NOM	MAX	MIN	NOM	MAX	
Supply voltage, V_{CC}	4.5	5	5.5	4.75	5	5.25	V
High-level output current, I_{OH}			-400			-400	μ A
Low-level output current, I_{OL}			4			8	mA
Width of clock input pulse, t_W	25			25			ns
Setup time, t_{SU} (see Figure 1)	25			25			ns
Hold time, t_H (see Figure 1)	0			0			ns
Operating free-air temperature, T_A	-55		125	0		70	C

electrical characteristics over recommended operating free-air temperature range (unless otherwise noted)

PARAMETER	TEST CONDITIONS†	SN54LS91			SN74LS91			UNIT
		MIN	TYP‡	MAX	MIN	TYP‡	MAX	
V_{IH} High-level input voltage		2			2			V
V_{IL} Low-level input voltage				0.7			0.8	V
V_{IK} Input clamp voltage	$V_{CC} = \text{MIN}, I_I = -18 \text{ mA}$			-1.5			-1.5	V
V_{OH} High-level output voltage	$V_{CC} = \text{MIN}, V_{IH} = 2 \text{ V}, V_{IL} = V_{IL \text{ max}}, I_{OH} = -400 \mu\text{A}$	2.5	3.5		2.7	3.5		V
V_{OL} Low-level output voltage	$V_{CC} = \text{MIN}, V_{IH} = 2 \text{ V}, V_{IL} = V_{IL \text{ max}}$			0.25	0.4	0.25	0.4	V
				$I_{OL} = 4 \text{ mA}$			0.35	0.5
				$I_{OL} = 8 \text{ mA}$				
I_I Input current at maximum input voltage	$V_{CC} = \text{MAX}, V_I = 7 \text{ V}$			0.1			0.1	mA
I_{IH} High-level input current	$V_{CC} = \text{MAX}, V_I = 2.7 \text{ V}$			20			20	μ A
I_{IL} Low-level input current	$V_{CC} = \text{MAX}, V_I = 0.4 \text{ V}$			-0.4			-0.4	mA
I_{OS} Short-circuit output current§	$V_{CC} = \text{MAX}$	-20		-100	-20		-100	mA
I_{CC} Supply current	$V_{CC} = \text{MAX}, \text{ See Note 3}$		12	20		12	20	mA

† For conditions shown as MIN or MAX, use the appropriate value specified under recommended operating conditions.

‡ All typical values are at $V_{CC} = 5 \text{ V}, T_A = 25 \text{ C}$.

§ Not more than one output should be shorted at a time, and duration of the short-circuit should not exceed one second.

NOTE 3: I_{CC} is measured after the eighth clock pulse with the output open and A and B inputs grounded.

switching characteristics, $V_{CC} = 5 \text{ V}, T_A = 25^\circ \text{C}$

PARAMETER	TEST CONDITIONS	MIN	TYP	MAX	UNIT
f_{max} Maximum clock frequency	$C_L = 15 \text{ pF}$	10	18		MHz
t_{PLH} Propagation delay time, low-to-high-level output	$R_L = 2 \text{ k}\Omega$		24	40	ns
t_{PHL} Propagation delay time, high-to-low-level output	See Figure 1		27	40	ns

3

TTL DEVICES

TYPES SN5491A, SN54L91, SN54LS91, SN7491A, SN74LS91
8-BIT SHIFT REGISTERS

PARAMETER MEASUREMENT INFORMATION

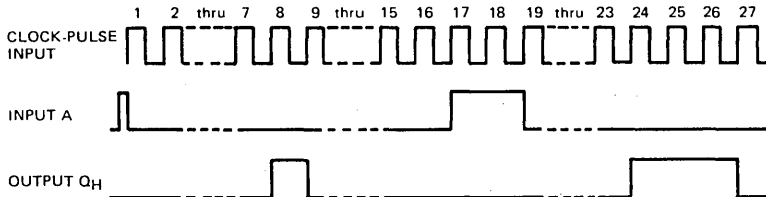
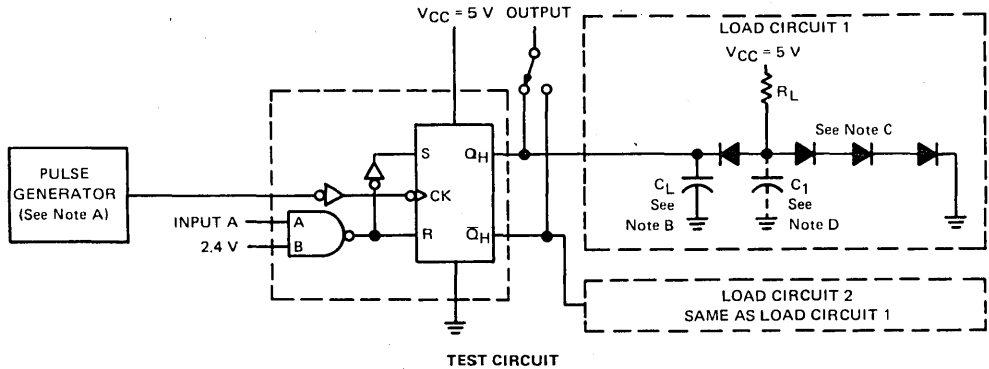

TYPICAL INPUT/OUTPUT WAVEFORMS

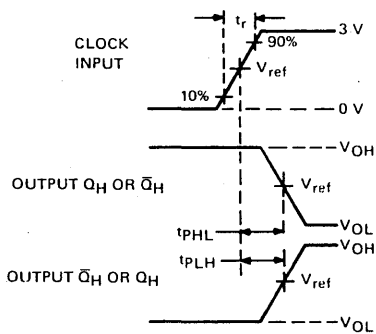

PROPAGATION DELAY TIMES VOLTAGE WAVEFORMS

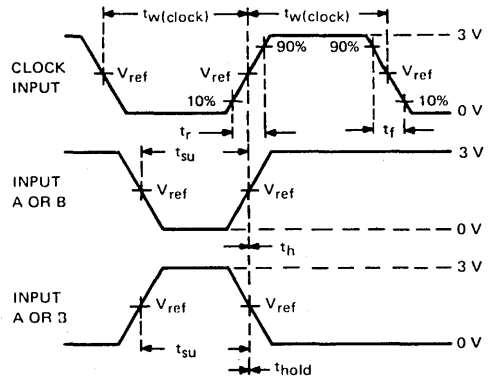

SWITCHING TIMES VOLTAGE WAVEFORMS

- NOTES: A. The generator has the following characteristics: $t_w(\text{clock}) = 500 \text{ ns}$, $\text{PRR} \leq 1 \text{ MHz}$, $Z_{\text{out}} \approx 50 \Omega$. For SN5491A/SN7491A, $t_r \leq 10 \text{ ns}$ and $t_f \leq 10 \text{ ns}$; for SN54L91, $t_r \leq 15 \text{ ns}$ and $t_f \leq 15 \text{ ns}$; and for SN54LS91, $t_r = 15 \text{ ns}$, and $t_f = 6 \text{ ns}$.
- B. C_L includes probe and jig capacitance.
- C. All diodes are 1N3064 or equivalent.
- D. $C_1 = 30 \text{ pF}$ and is used for SN54L91 only.
- E. For SN5491A/SN7491A, $V_{\text{ref}} = 1.5 \text{ V}$; for SN54L91 and SN54LS91/SN74LS91, $V_{\text{ref}} = 1.3 \text{ V}$.

FIGURE 1—SWITCHING TIMES

TTL MSI PARALLEL-IN SERIAL-OUT REGISTERS
for application as

- Dual-Source, Parallel-To-Serial Converter
- Serial-In Serial-Out Register

description

These monolithic shift registers which utilize transistor-transistor logic (TTL) circuits in the familiar Series 54/74 configuration, are composed of four R-S master-slave flip-flops, four AND-OR-INVERT gates, and four inverter-drivers. Internal interconnections of these functions provide a versatile register which performs right-shift operations as a serial-in, serial-out register or as a dual-source, parallel-to-serial converter. A number of these registers may be connected in series to form an n-bit register.

All flip-flops are simultaneously set to a low output level by applying a high-level voltage to the clear input while the internal presets are inactive (high). See the preset function table below. Clearing is independent of the level of the clock input.

The register may be parallel loaded by using the clear input in conjunction with the preset inputs. After clearing all stages to low output levels, data to be loaded is applied to either the P1 or P2 inputs of each register stage (A, B, C, and D) with the corresponding preset enable input, PE1 or PE2, high. Presetting, like clearing, is independent of the level of the clock input.

Transfer of information to the outputs occurs on the positive-going edge of the clock pulse. The proper information must be setup at the R-S inputs of each flip-flop prior to the rising edge of the clock input waveform. The serial input provides this information for the first flip-flop, while the outputs of the subsequent flip-flops provide information for the remaining R-S inputs. The clear input must be at a low level and the internal presets must be inactive (high) when clocking occurs.

SN5494 . . . J OR W PACKAGE
SN7494 . . . J OR N PACKAGE
(TOP VIEW)

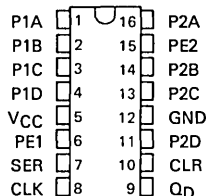

PRESET FUNCTION TABLE
(BIT A, TYPICAL OF ALL)

PRESET INPUTS				INTERNAL PRESET A
PE1	P1A	PE2	P2A	
L	X	L	X	H (inactive)
L	X	X	L	H (inactive)
X	L	L	X	H (inactive)
X	L	X	L	H (inactive)
H	H	X	X	L (active)
X	X	H	H	L (active)

REGISTER FUNCTION TABLE

INTERNAL PRESETS				INPUTS			INTERNAL OUTPUTS			OUTPUT
A	B	C	D	CLEAR	CLOCK	SERIAL	QA	QB	QC	QD
H	H	H	H	H	X	X	L	L	L	L
L	L	L	L	L	X	X	H	H	H	H
H	H	H	H	L	L	X	QA0	QB0	QC0	QD0
L	H	L	H	L	L	X	H	QB0	H	QD0
H	H	H	H	L	↑	H	H	QA _n	QB _n	QC _n
H	H	H	H	L	↑	L	L	QA _n	QB _n	QC _n

H = high level (steady state), L = low level (steady state), X = irrelevant, ↑ = transition from low to high level
QA0, QB0, QC0, QD0 = the level of QA, QB, QC, or QD, respectively, before the indicated steady-state input conditions were established.
QA_n, QB_n, QC_n = the level of QA, QB, or QC, respectively, before the most-recent ↑ transition of the clock.

absolute maximum ratings over operating free-air temperature range (unless otherwise noted)

Supply voltage, V _{CC} (see Note 1)	7 V
Input voltage (see Note 2)	5.5 V
Operating free-air temperature range: SN5494 Circuits	-55°C to 125°C
SN7494 Circuits	0°C to 70°C
Storage temperature range	-65°C to 150°C

- NOTES: 1. Voltage values are with respect to network ground terminal.
2. Input voltage must be zero or positive with respect to network ground terminal.

PRODUCTION DATA
This document contains information current as of publication date. Products conform to specifications per the terms of Texas Instruments standard warranty. Production processing does not necessarily include testing of all parameters.



POST OFFICE BOX 225012 • DALLAS, TEXAS 75265

logic diagram

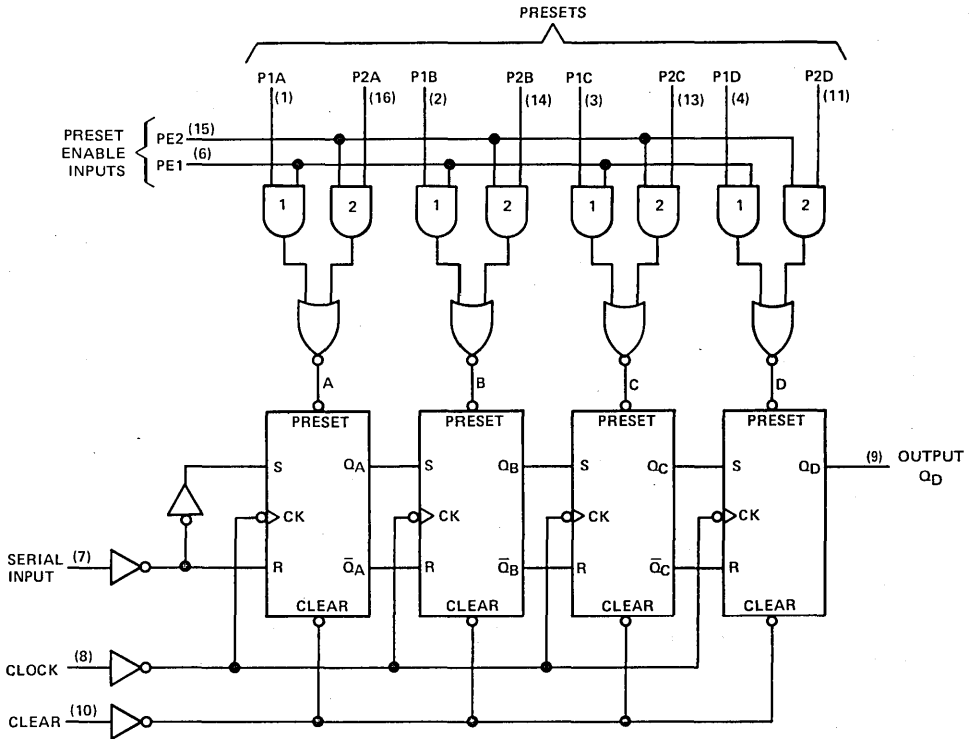

Pin numbers shown on logic notation are for J or N packages.

schematics of inputs and output

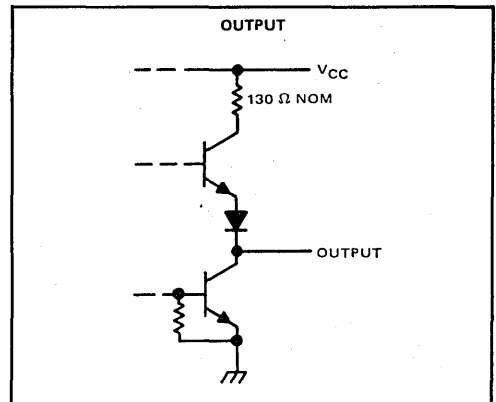
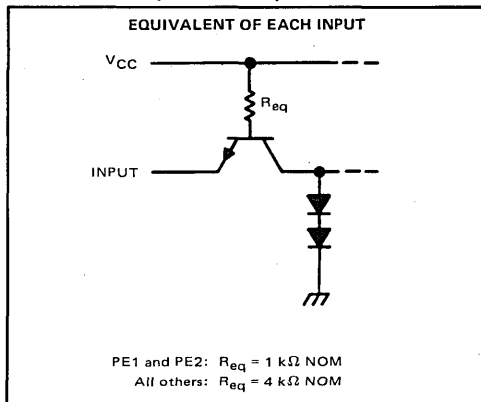

TYPES SN5494, SN7494 4-BIT SHIFT REGISTERS

recommended operating conditions

	SN5494			SN7494			UNIT
	MIN	NOM	MAX	MIN	NOM	MAX	
Supply voltage, V_{CC}	4.5	5	5.5	4.75	5	5.25	V
High-level output current, I_{OH}	-400			-400			μ A
Low-level output current, I_{OL}	16			16			mA
Width of clock pulse, $t_w(\text{clock})$	35			35			ns
Width of clear pulse, $t_w(\text{clear})$	30			30			ns
Width of preset pulse, $t_w(\text{preset})$	30			30			ns
Setup time, t_{su}	High-level data			35			ns
	Low-level data			25			
Hold time, t_h	0			0			ns
Operating free-air temperature, T_A	-55			125			$^{\circ}$ C

electrical characteristics over recommended operating free-air temperature range (unless otherwise noted)

PARAMETER		TEST CONDITIONS [†]	SN5494			SN7494			UNIT
			MIN	TYP [‡]	MAX	MIN	TYP [‡]	MAX	
V_{IH}	High-level input voltage		2			2			V
V_{IL}	Low-level input voltage		0.8			0.8			V
V_{OH}	High-level output voltage	$V_{CC} = \text{MIN}, V_{IH} = 2 \text{ V}, V_{IL} = 0.8 \text{ V}, I_{OH} = -400 \mu\text{A}$	2.4	3.5		2.4	3.5		V
V_{OL}	Low-level output voltage	$V_{CC} = \text{MIN}, V_{IH} = 2 \text{ V}, V_{IL} = 0.8 \text{ V}, I_{OL} = 16 \text{ mA}$		0.2	0.4		0.2	0.4	V
I_I	Input current at maximum input voltage	$V_{CC} = \text{MAX}, V_I = 5.5 \text{ V}$	1			1			mA
I_{IH}	High-level input current	Presets 1 and 2	$V_{CC} = \text{MAX}, V_I = 2.4 \text{ V}$			160			μ A
		Other inputs				40			
I_{IL}	Low-level input current	Presets 1 and 2	$V_{CC} = \text{MAX}, V_I = 0.4 \text{ V}$			-6.4			mA
		Other inputs				-1.6			
I_{OS}	Short-circuit output current [§]	$V_{CC} = \text{MAX}$	-20		-57	-18		-57	mA
I_{CC}	Supply current	$V_{CC} = \text{MAX}$, See Note 3	35			50			mA

[†] For conditions shown as MIN or MAX, use the appropriate value specified under recommended operating conditions.

[‡] All typical values are at $V_{CC} = 5 \text{ V}, T_A = 25^{\circ}\text{C}$.

[§] Not more than one output should be shorted at a time.

NOTE 3: I_{CC} is measured with the outputs open, clear grounded following momentary application of 4.5 V, both preset-enable inputs grounded, and all other inputs at 4.5 V.

switching characteristics, $V_{CC} = 5 \text{ V}, T_A = 25^{\circ}\text{C}$

PARAMETER		TEST CONDITIONS	MIN	TYP	MAX	UNIT	
f_{max}	Maximum clock frequency		10			MHz	
t_{PLH}	Propagation delay time, low-to-high-level output from clock	$C_L = 15 \text{ pF}, R_L = 400 \Omega,$ See Note 4	25			40	ns
t_{PHL}	Propagation delay time, high-to-low-level output from clock		25			40	ns
t_{PLH}	Propagation delay time, low-to-high-level output from preset					35	ns
t_{PHL}	Propagation delay time, high-to-low-level output from clear					40	ns

NOTE 4: See General Information Section for load circuits and voltage waveforms.

**TYPES SN5495A, SN54L95, SN54LS95B,
SN7495A, SN74LS95B**
4-BIT PARALLEL-ACCESS SHIFT REGISTERS
MARCH 1974 — REVISED DECEMBER 1983

TYPE	TYPICAL MAXIMUM		TYPICAL
	CLOCK FREQUENCY	POWER DISSIPATION	
'95A	36 MHz	195 mW	
'L95	5 MHz	19 mW	
'LS95B	36 MHz	65 mW	

description

These 4-bit registers feature parallel and serial inputs, parallel outputs, mode control, and two clock inputs. The registers have three modes of operation:

- Parallel (broadside) load
- Shift right (the direction Q_A toward Q_D)
- Shift left (the direction Q_D toward Q_A)

Parallel loading is accomplished by applying the four bits of data and taking the mode control input high. The data is loaded into the associated flip-flops and appears at the outputs after the high-to-low transition of the clock-2 input. During loading, the entry of serial data is inhibited.

Shift right is accomplished on the high-to-low transition of clock 1 when the mode control is low; shift left is accomplished on the high-to-low transition of clock 2 when the mode control is high by connecting the output of each flip-flop to the parallel input of the previous flip-flop (Q_D to input C, etc.) and serial data is entered at input D. The clock input may be applied commonly to clock 1 and clock 2 if both modes can be clocked from the same source. Changes at the mode control input should normally be made while both clock inputs are low; however, conditions described in the last three lines of the function table will also ensure that register contents are protected.

FUNCTION TABLE

MODE CONTROL		INPUTS				OUTPUTS					
		CLOCKS		SERIAL	PARALLEL			Q_A	Q_B	Q_C	Q_D
		2 (L)	1 (R)		A	B	C				
H	H	X	X	X	X	X	X	Q_{A0}	Q_{B0}	Q_{C0}	Q_{D0}
H	↓	X	X	a	b	c	d	a	b	c	d
H	↓	X	X	$Q_B↑$	$Q_C↑$	$Q_D↑$	d	Q_{Bn}	Q_{Cn}	Q_{Dn}	d
L	L	H	X	X	X	X	X	Q_{A0}	Q_{B0}	Q_{C0}	Q_{D0}
L	X	↓	H	X	X	X	X	H	Q_{An}	Q_{Bn}	Q_{Cn}
L	X	↓	L	X	X	X	X	L	Q_{An}	Q_{Bn}	Q_{Cn}
↑	L	L	X	X	X	X	X	Q_{A0}	Q_{B0}	Q_{C0}	Q_{D0}
↓	L	L	X	X	X	X	X	Q_{A0}	Q_{B0}	Q_{C0}	Q_{D0}
↓	L	H	X	X	X	X	X	Q_{A0}	Q_{B0}	Q_{C0}	Q_{D0}
↑	H	L	X	X	X	X	X	Q_{A0}	Q_{B0}	Q_{C0}	Q_{D0}
↑	H	H	X	X	X	X	X	Q_{A0}	Q_{B0}	Q_{C0}	Q_{D0}

↑ Shifting left requires external connection of Q_B to A, Q_C to B, and Q_D to C. Serial data is entered at input D.

H = high level (steady state), L = low level (steady state), X = irrelevant (any input, including transitions)

↓ = transition from high to low level, ↑ = transition from low to high level

a, b, c, d = the level of steady-state input at inputs A, B, C, or D, respectively.

Q_{A0} , Q_{B0} , Q_{C0} , Q_{D0} = the level of Q_A , Q_B , Q_C , or Q_D , respectively, before the indicated steady-state input conditions were established.

Q_{An} , Q_{Bn} , Q_{Cn} , Q_{Dn} = the level of Q_A , Q_B , Q_C , or Q_D , respectively, before the most-recent ↓ transition of the clock.

SN5495A, SN54LS95B ... J OR W PACKAGE
SN7495A ... J OR N PACKAGE
SN74LS95B ... D, J OR N PACKAGE
(TOP VIEW)

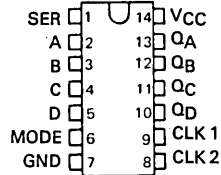

SN54L95 ... J PACKAGE
(TOP VIEW)

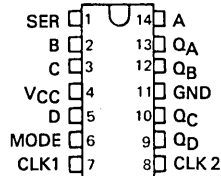

SN54LS95B ... FK PACKAGE
SN74LS95B ... FN PACKAGE
(TOP VIEW)

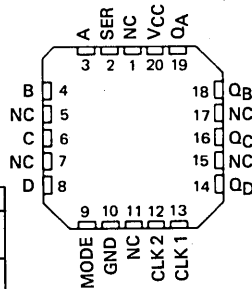

NC - No internal connection

PRODUCTION DATA
This document contains information current as of publication date. Products conform to specifications per the terms of Texas Instruments standard warranty. Production processing does not necessarily include testing of all parameters.



TYPES SN5495A, SN54L95, SN54LS95B, SN7495A, SN74LS95B
4-BIT PARALLEL-ACCESS SHIFT REGISTERS

logic diagrams

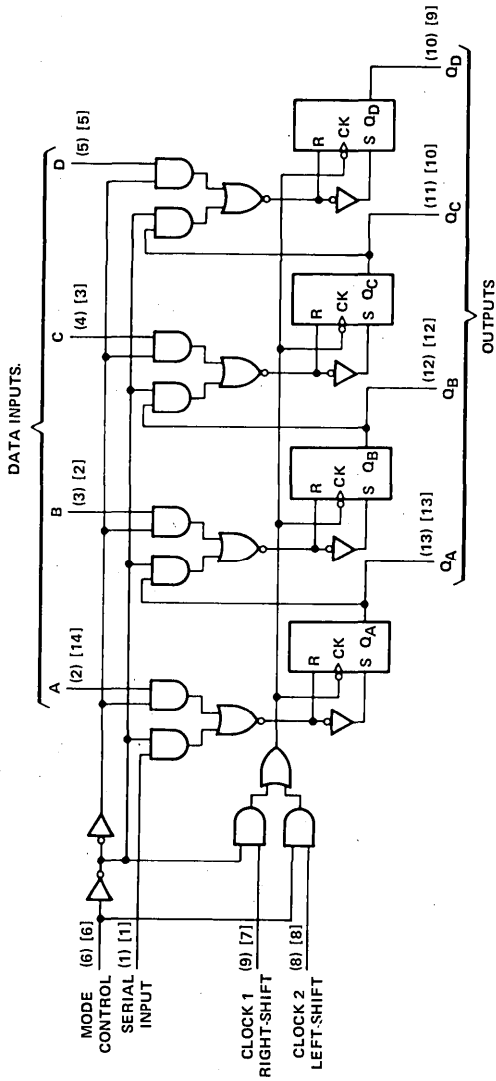

Pin numbers shown in () are for the 'LS95B and '95A and pin numbers shown in [] are for the 54L95.

TYPES SN5495A, SN54L95, SN54LS95B, SN7495A, SN74LS95B 4-BIT PARALLEL-ACCESS SHIFT REGISTERS

schematics of inputs and outputs

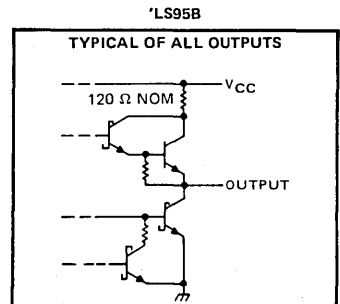
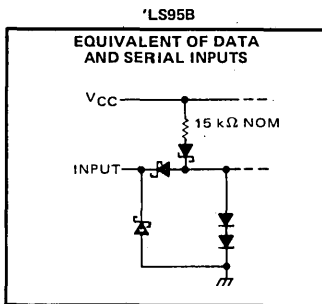
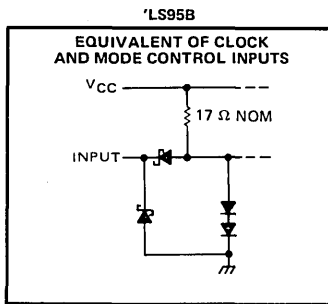
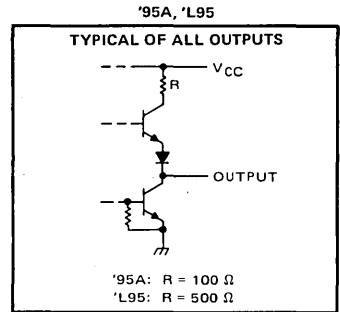
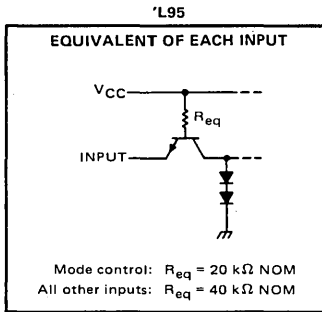
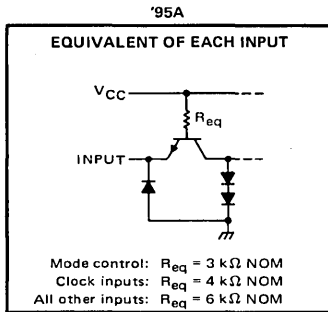

absolute maximum ratings over operating free-air temperature range (unless otherwise noted)

	SN54'	SN54L'	SN54LS'	SN74'	SN74LS'	UNIT
Supply voltage, V_{CC} (see Note 1)	7	8	7	7	7	V
Input voltage (see Note 2)	5.5	5.5	7	5.5	7	V
Interemitter voltage (see Note 3)	5.5	5.5		5.5		V
Operating free-air temperature range	- 55 to 125		0 to 70			$^{\circ}\text{C}$
Storage temperature range	- 65 to 150		- 65 to 150			$^{\circ}\text{C}$

- NOTES: 1. Voltage values, except interemitter voltage, are with respect to network ground terminal.
 2. For the 'L95, input voltages must be zero or positive with respect to network ground terminal.
 3. This is the voltage between two emitters of a multiple-emitter input transistor. This rating applies between the clock-2 input and the mode control input of the '95A and 'L95.

3

TTL DEVICES

TYPES SN5495A, SN7495A

4-BIT PARALLEL- SHIFT REGISTERS

recommended operating conditions

	SN5495A			SN7495A			UNIT
	MIN	NOM	MAX	MIN	NOM	MAX	
Supply voltage, V_{CC}	4.5	5	5.5	4.75	5	5.25	V
High-level output current, I_{OH}			-800			-800	μ A
Low-level output current, I_{OL}			16			16	mA
Clock frequency, f_{clock}	0		25	0		25	MHz
Width of clock pulse, $t_w(\text{clock})$ (See Figure 1)	20			20			ns
Setup time, high-level or low-level data, t_{SU} (See Figure 1)	15			15			ns
Hold time, high-level or low-level data, t_H (See Figure 1)	0			0			ns
Time to enable clock 1, $t_{enable 1}$ (See Figure 2)	15			15			ns
Time to enable clock 2 (See Figure 2)	15			15			ns
Time to inhibit clock 1, $t_{inhibit 1}$ (See Figure 2)	5			5			ns
Time to inhibit clock 2, $t_{inhibit 2}$ (See Figure 2)	5			5			ns
Operating free-air temperature, T_A	-55		125	0		70	$^{\circ}$ C

electrical characteristics over recommended operating free-air temperature range (unless otherwise noted)

PARAMETER		TEST CONDITIONS†	SN5495A			SN7495A			UNIT
			MIN	TYP‡	MAX	MIN	TYP‡	MAX	
V_{IH}	High-level input voltage		2			2			V
V_{IL}	Low-level input voltage				0.8			0.8	V
V_{IK}	Input clamp voltage	$V_{CC} = \text{MIN}, I_I = -12 \text{ mA}$			-1.5			-1.5	V
V_{OH}	High-level output voltage	$V_{CC} = \text{MIN}, V_{IH} = 2 \text{ V}, V_{IL} = 0.8 \text{ V}, I_{OH} = -800 \mu\text{A}$	2.4	3.4		2.4	3.4		V
V_{OL}	Low-level output voltage	$V_{CC} = \text{MIN}, V_{IH} = 2 \text{ V}, V_{IL} = 0.8 \text{ V}, I_{OL} = 16 \text{ mA}$		0.2	0.4		0.2	0.4	V
I_I	Input current at maximum input voltage	$V_{CC} = \text{MAX}, V_I = 5.5 \text{ V}$			1			1	mA
I_{IH}	High-level input current	Serial, A, B, C, D, Clock 1 or 2			40			40	μ A
		Mode control			80			80	
I_{IL}	Low-level input current	Serial, A, B, C, D, Clock 1 or 2			-1.6			-1.6	mA
		Mode control			-3.2			-3.2	
I_{OS}	Short-circuit output current§	$V_{CC} = \text{MAX}$	-18		-57	-18		-57	mA
I_{CC}	Supply current	$V_{CC} = \text{MAX}$, See Note 4		39	63		39	63	mA

† For conditions shown as MIN or MAX, use the appropriate value specified under recommended operating conditions.

‡ All typical values are at $V_{CC} = 5 \text{ V}, T_A = 25^{\circ}\text{C}$.

§ Not more than one output should be shorted at a time.

NOTE 4: I_{CC} is measured with all outputs and serial input open; A, B, C, and D inputs grounded; mode control at 4.5 V; and a momentary 3 V, then ground, applied to both clock inputs.

switching characteristics, $V_{CC} = 5 \text{ V}, T_A = 25^{\circ}\text{C}$

PARAMETER	TEST CONDITIONS	MIN	TYP	MAX	UNIT
f_{max} Maximum clock frequency	$C_L = 15 \text{ pF}, R_L = 400 \Omega$, See Figure 1		25	36	MHz
t_{PLH} Propagation delay time, low-to-high-level output from clock			18	27	ns
t_{PHL} Propagation delay time, high-to-low-level output from clock				21	32

TYPES SN54L95
4-BIT PARALLEL-ACCESS SHIFT REGISTERS

recommended operating conditions

		SN54L95			UNIT
		MIN	NOM	MAX	
V_{CC}	Supply voltage	4.5	5	5.5	V
V_{IH}	High-level input voltage	2			V
V_{IL}	Low-level input voltage	0.7			V
I_{OH}	High-level output current	-0.1			mA
I_{OL}	Low-level output current	2			mA
f_{clock}	Clock frequency	0	3		MHz
$t_w(\text{clock})$	Width of clock pulse (See Figure 1)	200			ns
t_{su}	Setup time (See Figure 1)	High-level data		100	ns
		Low-level data		120	ns
t_h	Hold time, high-level or low-level data (See Figure 1)	0			ns
$t_{enable 1}$	Time to enable clock 1 (See Figure 2)	225			ns
$t_{enable 2}$	Time to enable clock 2 (See Figure 2)	200			ns
$t_{inhibit 1}$	Time to inhibit clock 1 (See Figure 2)	100			ns
$t_{inhibit 2}$	Time to inhibit clock 2 (See Figure 2)	0			ns
T_A	Operating free-air temperature	-55	125		°C

electrical characteristics over recommended operating free-air temperature range (unless otherwise noted)

PARAMETER		TEST CONDITIONS†				SN54L95			UNIT
						MIN	TYP‡	MAX	
V_{OH}		$V_{CC} = \text{MIN}, V_{IH} = 2 \text{ V}, V_{IL} = 0.7 \text{ V}, I_{OH} = -0.1 \text{ mA}$				2.4	3.3		V
V_{OL}		$V_{CC} = \text{MIN}, V_{IH} = 2 \text{ V}, V_{IL} = 0.7 \text{ V}, I_{OL} = 2 \text{ mA}$				0.15	0.3		V
I_I	Serial, A, B, C, D, Clock 1 or 2	$V_{CC} = \text{MAX}, V_I = 5.5 \text{ V}$						0.1	mA
	Mode control								
I_{IH}	Serial, A, B, C, D, Clock 1 or 2	$V_{CC} = \text{MAX}, V_I = 2.4 \text{ V}$						10	µA
	Mode control								
I_{IL}	Serial, A, B, C, D, Clock 1 or 2	$V_{CC} = \text{MAX}, V_{II} = 0.3 \text{ V}$						-0.18	mA
	Mode control								
$I_{OS}§$		$V_{CC} = \text{MAX}$				-3	-15		mA
I_{CC}		$V_{CC} = \text{MAX},$ See Note 4				3.8	9		mA

† For conditions shown as MIN or MAX, use the appropriate value specified under recommended operating conditions.

‡ All typical values are at $V_{CC} = 5 \text{ V}, T_A = 25^\circ\text{C}$.

§ Not more than one output should be shorted at a time.

NOTE 4: I_{CC} is measured with all outputs and serial input open; A, B, C, and D inputs grounded; mode control at 4.5 V; and a momentary 3 V, then ground, applied to both clock inputs.

switching characteristics, $V_{CC} = 5 \text{ V}, T_A = 25^\circ\text{C}$

PARAMETER	FROM (INPUT)	TO (OUTPUT)	TEST CONDITIONS		MIN	TYP	MAX	UNIT
f_{max}	Any	Any	$R_L = 4 \text{ k}\Omega$ See Figure 1	$C_L = 50 \text{ pF}$	3	5		MHz
t_{PLH}					115	200		ns
t_{PHL}					125	200		ns

3
TTL DEVICES

TYPES SN54LS95B, SN74LS95B 4-BIT PARALLEL-ACCESS SHIFT REGISTERS

recommended operating conditions

	SN54LS95B			SN74LS95B			UNIT
	MIN	NOM	MAX	MIN	NOM	MAX	
Supply voltage, V_{CC}	4.5	5	5.5	4.75	5	5.25	V
High-level output current, I_{OH}	-400			-400			μ A
Low-level output current, I_{OL}	4			8			mA
Clock frequency, f_{clock}	0			25			MHz
Width of clock pulse, $t_{w(clock)}$ (see Figure 1)	20			20			ns
Setup time, high-level or low-level data, t_{SU} (see Figure 1)	20			20			ns
Hold time, high-level or low-level data, t_H (see Figure 1)	20			10			ns
Time to enable clock 1, $t_{enable 1}$ (see Figure 2)	20			20			ns
Time to enable clock 2, $t_{enable 2}$ (see Figure 2)	20			20			ns
Time to inhibit clock 1, $t_{inhibit 1}$ (see Figure 2)	20			20			ns
Time to inhibit clock 2, $t_{inhibit 2}$ (see Figure 2)	20			20			ns
Operating free-air temperature, T_A	-55			125			$^{\circ}$ C

electrical characteristics over recommended operating free-air temperature range (unless otherwise noted)

PARAMETER	TEST CONDITIONS†	SN54LS95B			SN74LS95B			UNIT
		MIN	TYP‡	MAX	MIN	TYP‡	MAX	
V_{IH} High-level input voltage		2			2			V
V_{IL} Low-level input voltage		0.7			0.8			V
V_{IK} Input clamp voltage	$V_{CC} = \text{MIN}, I_I = -18 \text{ mA}$	-1.5			-1.5			V
V_{OH} High-level output voltage	$V_{CC} = \text{MIN}, V_{IH} = 2 \text{ V}, V_{IL} = V_{IL \text{ max}}, I_{OH} = -400 \mu\text{A}$	2.5	3.4		2.7	3.4		V
V_{OL} Low-level output voltage	$V_{CC} = \text{MIN}, V_{IH} = 2 \text{ V}, V_{IL} = V_{IL \text{ max}}$	$I_{OL} = 4 \text{ mA}$		0.25	0.4	0.25	0.4	V
		$I_{OL} = 8 \text{ mA}$				0.35	0.5	
I_I Input current at maximum input voltage	$V_{CC} = \text{MAX}, V_I = 7 \text{ V}$	0.1			0.1			mA
I_{IH} High-level input current	$V_{CC} = \text{MAX}, V_I = 2.7 \text{ V}$	20			20			μ A
I_{IL} Low-level input current	$V_{CC} = \text{MAX}, V_I = 0.4 \text{ V}$	-0.4			-0.4			mA
I_{OS} Short-circuit output current‡	$V_{CC} = \text{MAX}$	-20	-100		-20	-100		mA
I_{CC} Supply current	$V_{CC} = \text{MAX},$ See Note 4	13		21	13		21	mA

†For conditions shown as MIN or MAX, use the appropriate value specified under recommended operating conditions.

‡All typical values are at $V_{CC} = 5 \text{ V}, T_A = 25^{\circ}\text{C}$.

§Not more than one output should be shorted at a time, and duration of the short-circuit should not exceed one second.

NOTE 4: I_{CC} is measured with all outputs and serial input open; A, B, C, and D inputs grounded; mode control at 4.5 V; and a momentary 3 V, then ground, applied to both clock inputs.

switching characteristics, $V_{CC} = 5 \text{ V}, T_A = 25^{\circ}\text{C}$

PARAMETER	TEST CONDITIONS	MIN	TYP	MAX	UNIT
f_{max} Maximum clock frequency	$C_L = 15 \text{ pF}, R_L = 2 \text{ k}\Omega,$ See Figure 1	25	36		MHz
t_{PLH} Propagation delay time, low-to-high-level output from clock		18	27		ns
t_{PHL} Propagation delay time, high-to-low-level output from clock		21	32		ns

TYPES SN5495A, SN54L95, SN54LS95B, SN7495A, SN74LS95B 4-BIT PARALLEL-ACCESS SHIFT REGISTERS

PARAMETER MEASUREMENT INFORMATION

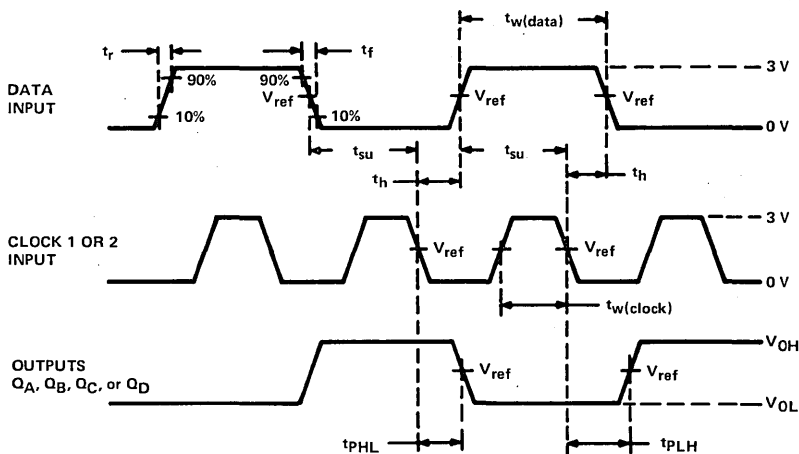
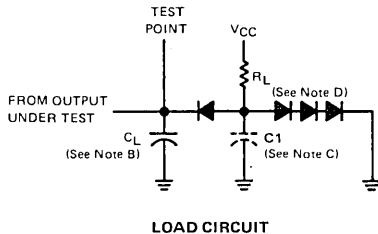

- NOTES: A. Input pulses are supplied by a generator having the following characteristics: $t_r \leq 10$ ns, $t_f \leq 10$ ns, and $Z_{out} \approx 50 \Omega$. For the data pulse generator, PRR = 500 kHz; for the clock pulse generator, PRR = 1 MHz. When testing t_{max} , vary PRR. For '95A, $t_w(data) \geq 20$ ns; $t_w(clock) \geq 15$ ns. For 'L95, $t_w(data) \geq 150$ ns; $t_w(clock) \geq 200$ ns. For 'LS95B, $t_w(data) \geq 20$ ns, $t_w(clock) \geq 15$ ns.
- B. C_L includes probe and jig capacitance.
- C. C_1 (30 pF) is applicable for testing 'L95.
- D. All diodes are 1N3064 equivalent.
- E. For '95A, $V_{ref} = 1.5$ V; for 'L95 and 'LS95B, $V_{ref} = 1.3$ V.

VOLTAGE WAVEFORMS
FIGURE 1-SWITCHING TIMES

3
TTL DEVICES

TYPES SN5495A, SN54L95, SN54LS95B, SN7495A, SN74LS95B
4-BIT PARALLEL-ACCESS SHIFT REGISTERS

PARAMETER MEASUREMENT INFORMATION

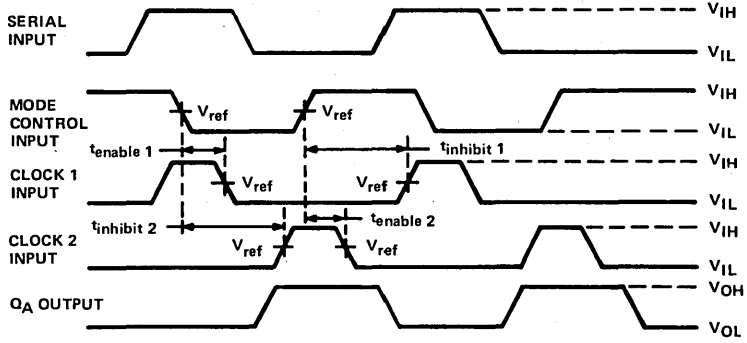

NOTES: A. Input A is at a low level.
 B. For '95A, $V_{ref} = 1.5$ V; for 'L95 and 'LS95B, $V_{ref} = 1.3$ V.

VOLTAGE WAVEFORMS
FIGURE 2-CLOCK ENABLE/INHIBIT TIMES



TTL DEVICES

TYPES SN5496, SN54L96, SN54LS96, SN7496, SN74LS96 5-BIT SHIFT REGISTERS

MARCH 1974—REVISED DECEMBER 1983

- N-Bit Serial-To-Parallel Converter
- N-Bit Parallel-To-Serial Converter
- N-Bit Storage Register

SN5496, SN54LS96 . . . J OR W PACKAGE
SN54L96 . . . J PACKAGE
SN7496 . . . J OR N PACKAGE
SN74LS96 . . . D, J OR N PACKAGE
(TOP VIEW)

TYPE	TYPICAL	
	PROPAGATION DELAY TIME	POWER DISSIPATION
'96	25 ns	240 mW
'L96	50 ns	120 mW
'LS96	25 ns	60 mW

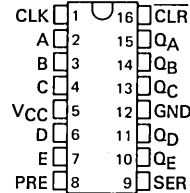

description

These shift registers consist of five R-S master-slave flip-flops connected to perform parallel-to-serial or serial-to-parallel conversion of binary data. Since both inputs and outputs for all flip-flops are accessible, parallel-in/parallel-out or serial-in/serial-out operation may be performed.

All flip-flops are simultaneously set to a low output level by applying a low-level voltage to the clear input while the preset is inactive (low). Clearing is independent of the level of the clock input.

The register may be parallel loaded by using the clear input in conjunction with the preset inputs. After clearing all stages to low output levels, data to be loaded is applied to the individual preset inputs (A, B, C, D, and E) and a high-level load pulse is applied to the preset enable input. Presetting like clearing is independent of the level of the clock input.

Transfer of information to the outputs occurs on the positive-going edge of the clock pulse. The proper information must be set up at the R-S inputs of each flip-flop prior to the rising edge of the clock input waveform. The serial input provides this information to the first flip-flop, while the outputs of the subsequent flip-flops provide information for the remaining R-S inputs. The clear input must be high and the preset or preset enable inputs must be low when clocking occurs.

For chip carrier information on SN54LS96 and SN74LS96, contact the factory.

FUNCTION TABLE

CLEAR	INPUTS					OUTPUTS							
	PRESET ENABLE	PRESET					CLOCK	SERIAL	Q _A	Q _B	Q _C	Q _D	Q _E
		A	B	C	D	E							
L	L	X	X	X	X	X	X	L	L	L	L	L	
L	X	L	L	L	L	X	X	L	L	L	L	L	
H	H	H	H	H	H	X	X	H	H	H	H	H	
H	H	L	L	L	L	L	X	Q _{A0}	Q _{B0}	Q _{C0}	Q _{D0}	Q _{E0}	
H	H	H	L	H	L	H	L	H	Q _{B0}	H	Q _{D0}	H	
H	L	X	X	X	X	L	X	Q _{A0}	Q _{B0}	Q _{C0}	Q _{D0}	Q _{E0}	
H	L	X	X	X	X	↑	H	H	Q _{An}	Q _{Bn}	Q _{Cn}	Q _{Dn}	
H	L	X	X	X	X	↑	L	L	Q _{An}	Q _{Bn}	Q _{Cn}	Q _{Dn}	

H = high level (steady state), L = low level (steady state)

X = irrelevant (any input, including transitions)

↑ = transition from low to high level

Q_{A0}, Q_{B0}, etc = the level of Q_A, Q_B, etc, respectively before the indicated steady-state input conditions were established.

Q_{An}, Q_{Bn}, etc = the level of Q_A, Q_B, etc, respectively before the most-recent ↑ transition of the clock.

PRODUCTION DATA

This document contains information current as of publication date. Products conform to specifications per the terms of Texas Instruments standard warranty. Production processing does not necessarily include testing of all parameters.

TEXAS
INSTRUMENTS

POST OFFICE BOX 225012 • DALLAS, TEXAS 75265

3

TTL DEVICES

**TYPES SN5496, SN54L96, SN54LS96,
SN7496, SN74LS96
5-BIT SHIFT REGISTERS**

typical clear, shift, preset, and shift sequences

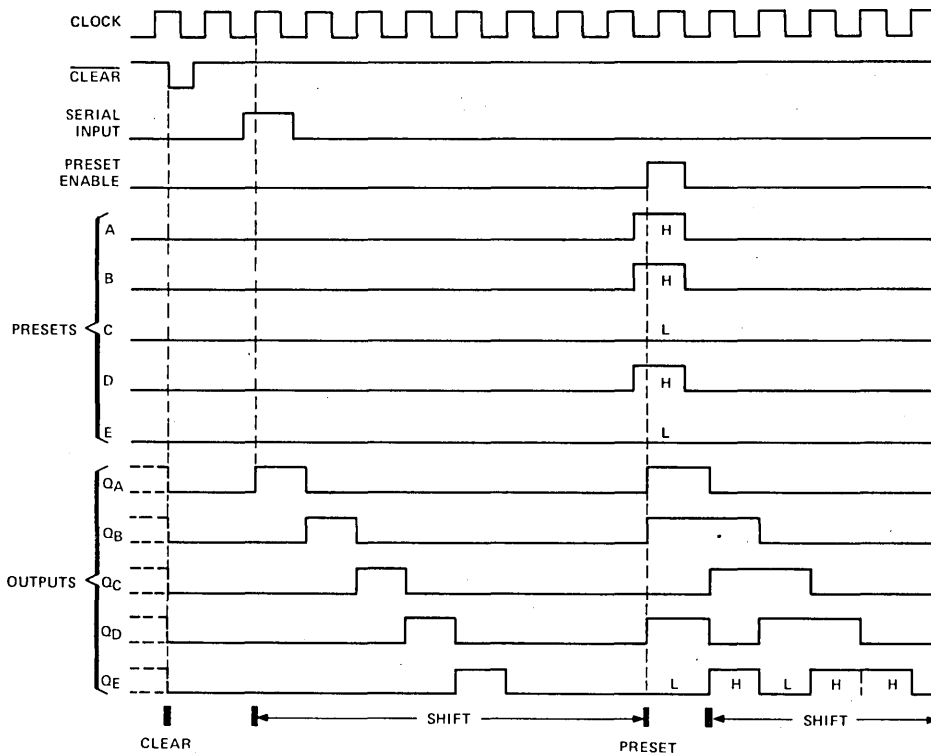

logic diagram

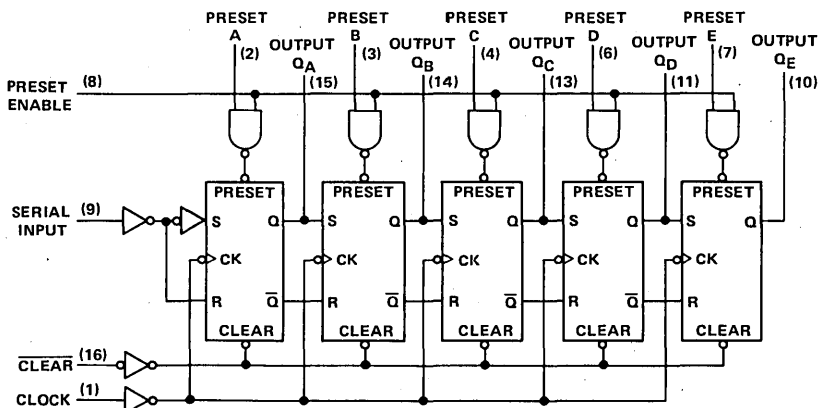

Pin numbers shown on logic notation are for D, J, or N packages.

TYPES SN5496, SN54L96, SN54LS96,
SN7496, SN74LS96
5-BIT SHIFT REGISTERS

schematics of inputs and outputs

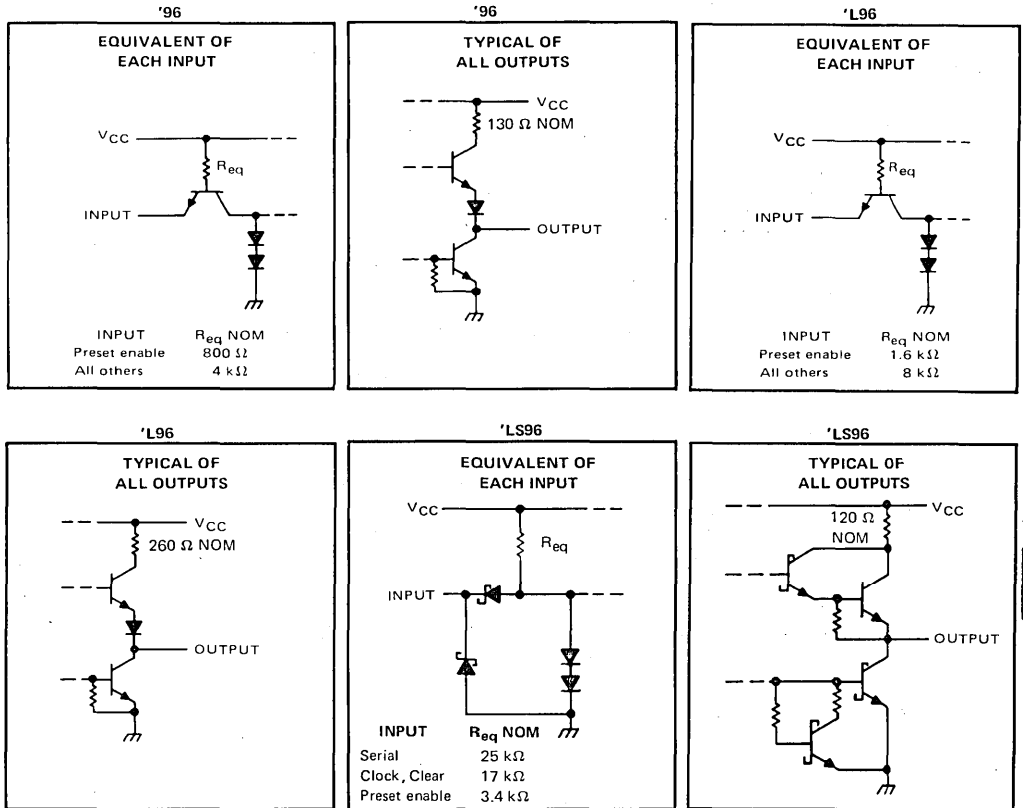

3
TTL DEVICES

absolute maximum ratings over operating free-air temperature (unless otherwise noted)

Supply voltage, V_{CC} (see Note 1)	7 V
Input voltage (see Note 2): '96, 'L96	5.5 V
'LS96	7 V
Operating free-air temperature: SN54'	-55°C to 125°C
SN74'	0°C to 70°C
Storage temperature range	-65°C to 150°C

NOTES: 1. Voltage values are with respect to network ground terminal.
2. Input voltages must be zero or positive with respect to network ground terminal.

TYPES SN5496, SN7496 5-BIT REGISTERS

recommended operating conditions

	SN5496			SN7496			UNIT
	MIN	NOM	MAX	MIN	NOM	MAX	
Supply voltage, V_{CC}	4.5	5	5.5	4.75	5	5.25	V
High-level output current, I_{OH}			-400			-400	μ A
Low-level output current, I_{OL}			16			16	mA
Clock frequency, f_{clock}	0		10	0		10	MHz
Width of clock input pulse, $t_{w(clock)}$		35			35		ns
Width of preset and clear input pulse, t_w		30			30		ns
Serial input setup time, t_{su} (see Figure 1)		30			30		ns
Serial input hold time, t_h (see Figure 1)		0			0		ns
Operating free-air temperature, T_A	-55		125	0		70	$^{\circ}$ C

electrical characteristics over recommended operating free-air temperature range (unless otherwise noted)

PARAMETER		TEST CONDITIONS†	SN5496		SN7496		UNIT
			MIN	TYP‡	MAX	MIN	
V_{IH}	High-level input voltage		2		2		V
V_{IL}	Low-level input voltage			0.8		0.8	V
V_{OH}	High-level output voltage	$V_{CC} = \text{MIN}, V_{IH} = 2 \text{ V}, V_{IL} = 0.8 \text{ V}, I_{OH} = -400 \mu\text{A}$	2.4	3.4	2.4	3.4	V
V_{OL}	Low-level output voltage	$V_{CC} = \text{MIN}, V_{IH} = 2 \text{ V}, V_{IL} = 0.8 \text{ V}, I_{OL} = 16 \text{ mA}$	0.2	0.4	0.2	0.4	V
I_I	Input current at maximum input voltage	$V_{CC} = \text{MAX}, V_I = 5.5 \text{ V}$		1		1	mA
I_{IH}	High-level input current	any input except preset enable		40		40	μ A
		preset enable		200		200	
I_{IL}	Low-level input current	any input except preset enable		-1.6		-1.6	mA
		preset enable		-8		-8	
I_{OS}	Short-circuit output current§	$V_{CC} = \text{MAX}$	-20	-57	-18	-57	mA
I_{CC}	Supply current	$V_{CC} = \text{MAX}$, See Note 3	48	68	48	79	mA

†For conditions shown at MIN or MAX, use the appropriate value specified under recommended operating conditions.

‡All typical values are at $V_{CC} = 5 \text{ V}, T_A = 25^{\circ}\text{C}$.

§Not more than one output should be shorted at a time.

NOTE 3: I_{CC} is measured with the clear input grounded and all other inputs and outputs open.

switching characteristics, $V_{CC} = 5 \text{ V}, T_A = 25^{\circ}\text{C}$

PARAMETER	TEST CONDITIONS	MIN	TYP	MAX	UNIT
t_{PLH}	Propagation delay time, low-to-high-level output from clock		25	40	ns
t_{PHL}	Propagation delay time, high-to-low-level output from clock		25	40	ns
t_{PLH}	Propagation delay time, low-to-high-level output from preset or preset enable		28	35	ns
t_{PHL}	Propagation delay time, high-to-low-level output from clear			55	ns

$C_L = 15 \text{ pF},$
 $R_L = 400 \Omega,$
See Figure 1

TYPE SN54L96 5-BIT SHIFT REGISTER

recommended operating conditions

		SN54L96			UNIT
		MIN	NOM	MAX	
V _{CC}	Supply voltage	4.5	5	5.5	V
V _{IH}	High-level input voltage	2			V
V _{IL}	Low-level input voltage	0.8			V
I _{OH}	High-level output current	-0.2			mA
I _{OL}	Low-level output current	8			mA
f _{clock}	Clock frequency	0	5		MHz
t _w	Width of clock, preset, or clear input	100			ns
t _{su}	Serial input setup time (See Figure 1)	100			ns
t _h	Serial input hold time (See Figure 1)	0			ns
T _A	Operating free-air temperature	-55	125		°C

electrical characteristics over recommended operating free-air temperature range (unless otherwise noted)

PARAMETER	TEST CONDITIONS†	SN54L96			UNIT
		MIN	TYP‡	MAX	
V _{OH}	V _{CC} = MIN, V _{IH} = 2 V, V _{IL} = 0.8 V, I _{OH} = -0.2 mA	2.4	3.2		V
V _{OL}	V _{CC} = MIN, V _{IH} = 2 V, V _{IL} = 0.8 V, I _{OL} = 8 mA		0.2	0.4	V
I _I	V _{CC} = MAX, V _I = 5.5 V			1	mA
I _{IH}	Any input except preset enable	V _{CC} = MAX, V _I = 2.4 V		20	μA
	Preset enable			0.1	mA
I _{IL}	Any input except preset enable	V _{CC} = MAX, V _I = 0.4 V		-0.8	mA
	Preset enable			-4	mA
I _{OS} §	V _{CC} = MAX	-10	-29		mA
I _{CC}	V _{CC} = MAX, See Note 3		24	34	mA

† For conditions shown at MIN or MAX, use the appropriate value specified under recommended operating conditions.

‡ All typical values are at V_{CC} = 5 V, T_A = 25°C.

§ Not more than one output should be shorted at a time.

NOTE 3: I_{CC} is measured with the clear input grounded and all other inputs and outputs open.

switching characteristics, V_{CC} = 5 V, T_A = 25°C

PARAMETER	FROM (INPUT)	TO (OUTPUT)	TEST CONDITIONS	MIN	TYP	MAX	UNIT
t _{PLH}	Clock	Any	R _L = 800 Ω, C _L = 15 pF See Figure 1		50	80	ns
t _{PHL}					50	80	ns
t _{PLH}	Preset or Preset enable				56	70	ns
t _{PHL}	Clear					110	ns

3
TTL DEVICES

TYPES SN54LS96, SN74LS96

5-BIT SHIFT REGISTERS

recommended operating conditions

	SN54LS96			SN74LS96			UNIT
	MIN	NOM	MAX	MIN	NOM	MAX	
Supply voltage, V_{CC}	4.5	5	5.5	4.75	5	5.25	V
High-level output current, I_{OH}			-400			-400	μ A
Low-level output current, I_{OL}			4			8	mA
Clock frequency, f_{clock}	0		25	0		25	MHz
Width of clock input pulse, $t_w(\text{clock})$	20			20			ns
Width of preset and clear input pulse, t_w	30			30			ns
Serial input setup time, t_{setup} (see Figure 1)	30			30			ns
Serial input hold time, t_{hold} (see Figure 1)	0			0			ns
Operating free-air temperature, T_A	-55		125	0		70	$^{\circ}$ C

electrical characteristics over recommended operating free-air temperature range (unless otherwise noted)

PARAMETER		TEST CONDITIONS†	SN54LS96			SN74LS96			UNIT	
			MIN	TYP‡	MAX	MIN	TYP‡	MAX		
V_{IH} High-level input voltage			2			2			V	
V_{IL} Low-level input voltage					0.7			0.8	V	
V_{IK} Input clamp voltage		$V_{CC} = \text{MIN}, I_I = -18 \text{ mA}$			-1.5			-1.5	V	
V_{OH} High-level output voltage		$V_{CC} = \text{MIN}, V_{IH} = 2 \text{ V}, V_{IL} = V_{IL \text{ max}}, I_{OH} = -400 \mu\text{A}$	2.5	3.5		2.7	3.5		V	
V_{OL} Low-level output voltage		$V_{CC} = \text{MIN}, V_{IH} = 2 \text{ V}, V_{IL} = V_{IL \text{ max}}$			$I_{OL} = 4 \text{ mA}$	0.25	0.4	$I_{OL} = 8 \text{ mA}$	0.25 0.4 0.35 0.5	V
I_I Input current at maximum input voltage	Preset enable	$V_{CC} = \text{MAX}, V_I = 7 \text{ V}$				0.5		0.5	mA	
	All others					0.1		0.1		
I_{IH} High-level input current	Preset enable	$V_{CC} = \text{MAX}, V_I = 2.7 \text{ V}$				100		100	μ A	
	All others					20		20		
I_{IL} Low-level input current	Preset enable	$V_{CC} = \text{MAX}, V_I = 0.4 \text{ V}$				-2		-2	mA	
	All others					-0.4		-0.4		
I_{OS} Short-circuit output current§		$V_{CC} = \text{MAX}$	-20		-100	-20		-100	mA	
I_{CC} Supply current		$V_{CC} = \text{MAX},$ See Note 3			12	20		12	20	mA

† For conditions shown at MIN or MAX, use the appropriate value specified under recommended operating conditions.

‡ All typical values are at $V_{CC} = 5 \text{ V}, T_A = 25^{\circ}\text{C}$.

§ Not more than one output should be shorted at a time, and duration of the short-circuit should not exceed one second.

NOTE 3: I_{CC} is measured with the clear input grounded and all other inputs and outputs open.

switching characteristics, $V_{CC} = 5 \text{ V}, T_A = 25^{\circ}\text{C}$

PARAMETER	TEST CONDITIONS	MIN	TYP	MAX	UNIT
t_{PLH} Propagation delay time, low-to-high-level output from clock	$C_L = 15 \text{ pF}, R_L = 2 \text{ k}\Omega,$ See Figure 1		25	40	ns
t_{PHL} Propagation delay time, high-to-low-level output from clock			25	40	ns
t_{PLH} Propagation delay time, low-to-high-level output from preset or preset enable			28	35	ns
t_{PHL} Propagation delay time, high-to-low-level output from clear				55	ns

TYPES SN5497, SN7497 SYNCHRONOUS 6-BIT BINARY RATE MULTIPLIERS

DECEMBER 1972—REVISED DECEMBER 1983

- Perform Fixed-Rate or Variable-Rate Frequency Division
- For Applications in Arithmetic, Radar, Digital-to-Analog (D/A), Analog-to-Digital (A/D), and other Conversion Operations
- Typical Maximum Clock Frequency . . . 32 Megahertz

SN5497 . . . J OR W PACKAGE
SN7497 . . . J OR N PACKAGE

(TOP VIEW)

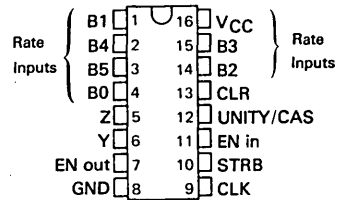

description

These monolithic, fully synchronous, programmable counters utilize Series 54/74 TTL circuitry to achieve 32-megahertz typical maximum operating frequencies. These six-bit serial binary counters feature buffered clock, clear, and enable inputs to control the operation of the counter, and a strobe input to enable or inhibit the rate input/decoding AND-OR-INVERT gates. The outputs have additional gating for cascading and transferring unity-count rates.

The counter is enabled when the clear, strobe, and enable inputs are low. With the counter enabled, the output frequency is equal to the input frequency multiplied by the rate input M and divided by 64, ie.:

$$f_{out} = \frac{M \cdot f_{in}}{64}$$

$$\text{where: } M = F \cdot 2^5 + E \cdot 2^4 + D \cdot 2^3 + C \cdot 2^2 + B \cdot 2^1 + A \cdot 2^0$$

When the rate input is binary 0 (all rate inputs low), Z remains high. In order to cascade devices to perform 12-bit rate multiplication, the enable output is connected to the enable and strobe inputs of the next stage, the Z output of each stage is connected to the unity/cascade input of the other stage, and the sub-multiple frequency is taken from the Y output.

The unity/cascade input, when connected to the clock input, may be utilized to pass the clock frequency (inverted) to the Y output when the rate input/decoding gates are inhibited by the strobe. The unity/cascade input may also be used as a control for the Y output.

schematics of inputs and outputs

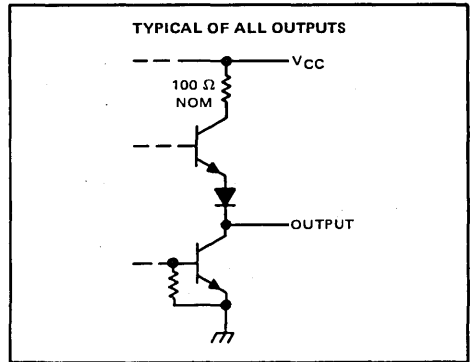
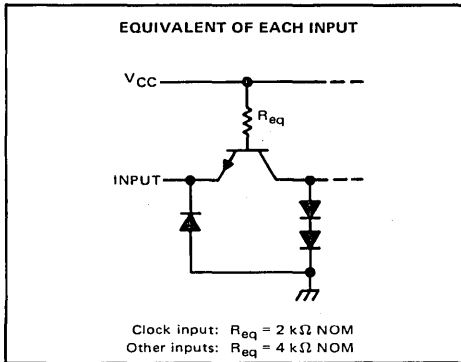

PRODUCTION DATA
This document contains information current as of publication date. Products conform to specifications per the terms of Texas Instruments standard warranty. Production processing does not necessarily include testing of all parameters.

TEXAS INSTRUMENTS
POST OFFICE BOX 225012 • DALLAS, TEXAS 75265

3-393

TYPES SN5497, SN7497
SYNCHRONOUS 6-BIT BINARY RATE MULTIPLIERS

description (continued)

STATE AND/OR RATE FUNCTION TABLE (See Note A)

CLEAR	ENABLE	STROBE	INPUTS				NUMBER OF CLOCK PULSES	UNITY/ CASCADE	OUTPUTS			NOTES		
			BINARY RATE						LOGIC LEVEL OR NUMBER OF PULSES					
			B5	B4	B3	B2			B1	B0	Y		Z	ENABLE
H	X	H	X	X	X	X	X	H	L	H	H	B		
L	L	L	L	L	L	L	64	H	L	H	1	C		
L	L	L	L	L	L	L	64	H	1	1	1	C		
L	L	L	L	L	L	H	64	H	2	2	1	C		
L	L	L	L	L	H	L	64	H	4	4	1	C		
L	L	L	L	L	H	L	64	H	8	8	1	C		
L	L	L	L	H	L	L	64	H	16	16	1	C		
L	L	L	H	L	L	L	64	H	32	32	1	C		
L	L	L	H	H	H	H	64	H	63	63	1	C		
L	L	L	H	H	H	H	64	L	H	63	1	D		
L	L	L	H	L	H	L	64	H	40	40	1	E		

- NOTES: A. H = high level, L = low level, X = irrelevant. All remaining entries are numeric counts.
 B. This is a simplified illustration of the clear function. The states of clock and strobe can affect the logic level of Y and Z. A low unity/cascade will cause output Y to remain high.
 C. Each rate illustrated assumes a constant value at rate inputs; however, these illustrations in no way prohibit variable-rate inputs.
 D. Unity/cascade is used to inhibit output Y.
 E. $f_{out} = \frac{M \cdot f_{in}}{64} = \frac{(8 + 32) f_{in}}{64} = \frac{40 f_{in}}{64} = 0.625 f_{in}$

3
TTL DEVICES

TYPES SN5497, SN7497
 SYNCHRONOUS 6-BIT BINARY RATE MULTIPLIERS

logic diagram

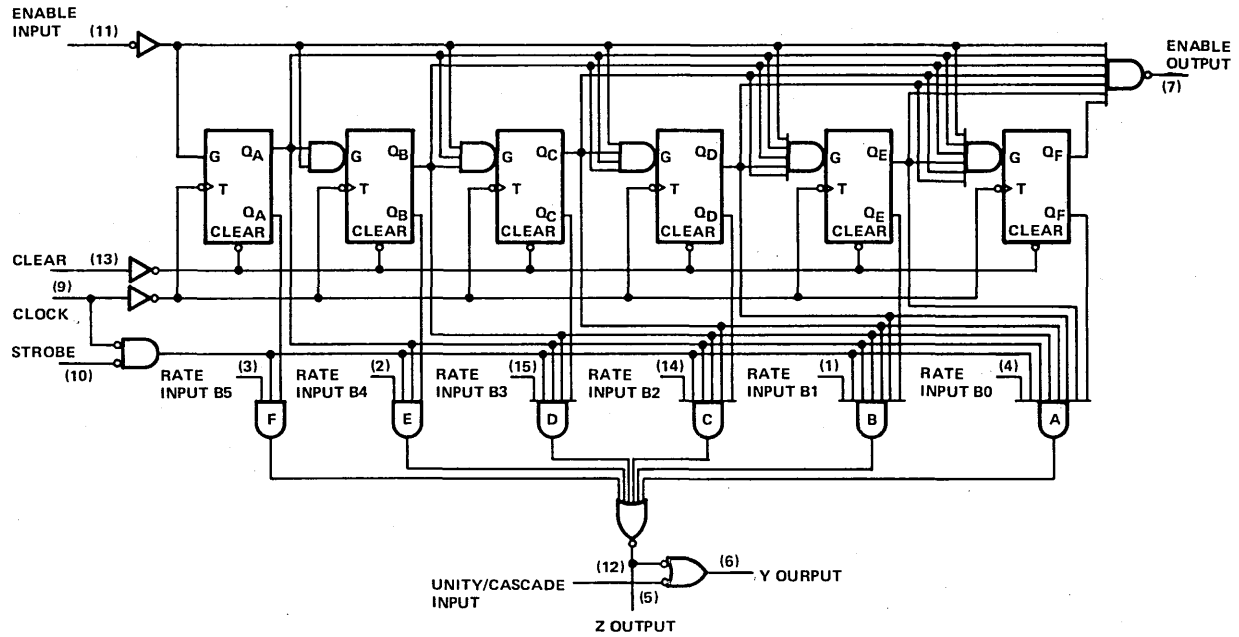

Pin numbers shown on logic notation are for J or N packages.

TTL DEVICES



TEXAS INSTRUMENTS
 POST OFFICE BOX 228012 • DALLAS, TEXAS 75285

3-395

TYPES SN5497, SN7497

SYNCHRONOUS 6-BIT BINARY RATE MULTIPLIERS

absolute maximum ratings over operating free-air temperature range (unless otherwise noted)

Supply voltage, V_{CC} (see Note 1)	7 V
Input voltage	5.5 V
Operating free-air temperature range: SN5497 (see Note 2)	-55°C to 125°C
SN7497	0°C to 70°C
Storage temperature range	-65°C to 150°C

recommended operating conditions

	SN5497			SN7497			UNIT
	MIN	NOM	MAX	MIN	NOM	MAX	
Supply voltage, V_{CC}	4.5	5	5.5	4.75	5	5.25	V
High-level output current, I_{OH}			-400			-400	μ A
Low-level output current, I_{OL}			16			16	mA
Clock frequency, f_{clock}	0		25	0		25	MHz
Width of clock pulse, $t_w(\text{clock})$	20			20			ns
Width of clear pulse, $t_w(\text{clear})$	15			15			ns
Enable setup time, t_{su} : (See Figure 1)							
Before positive-going transition of clock pulse	25			25			ns
Before negative-going transition of previous clock pulse	0	$t_w(\text{clock})-10$		0	$t_w(\text{clock})-10$		
Enable hold time, t_h : (See Figure 1)							
After positive-going transition of clock pulse	0	$t_w(\text{clock})-10$		0	$t_w(\text{clock})-10$		ns
After negative-going transition of previous clock pulse	20	$t_{cp}-10$		20	$t_{cp}-10$		
Operating free-air temperature, T_A (See Note 2)	-55		125	0		70	°C

electrical characteristics over recommended operating free-air temperature range (unless otherwise noted)

PARAMETER		TEST CONDITIONS†	MIN	TYP‡	MAX	UNIT
V_{IH}	High-level input voltage			2		V
V_{IL}	Low-level input voltage				0.8	V
V_{IK}	Input clamp voltage	$V_{CC} = \text{MIN}, I_I = -12 \text{ mA}$			-1.5	V
V_{OH}	High-level output voltage	$V_{CC} = \text{MIN}, V_{IH} = 2 \text{ V}, V_{IL} = 0.8 \text{ V}, I_{OH} = -400 \mu\text{A}$	2.4	3.4		V
V_{OL}	Low-level output voltage	$V_{CC} = \text{MIN}, V_{IH} = 2 \text{ V}, V_{IL} = 0.8 \text{ V}, I_{OL} = 16 \text{ mA}$		0.2	0.4	V
I_I	Input current at maximum input voltage	$V_{CC} = \text{MAX}, V_I = 5.5 \text{ V}$			1	mA
I_{IH}	High-level input current	clock input			80	μ A
		other inputs	$V_{CC} = \text{MAX}, V_I = 2.4 \text{ V}$		40	
I_{IL}	Low-level input current	clock input			-3.2	mA
		other inputs	$V_{CC} = \text{MAX}, V_I = 0.4 \text{ V}$		-1.6	
I_{OS}	Short circuit output current §	$V_{CC} = \text{MAX}$		-18	-55	mA
I_{CCH}	Supply current, outputs high	$V_{CC} = \text{MAX},$ See Note 3		58		mA
I_{CCL}	Supply current, outputs low	$V_{CC} = \text{MAX},$ See Note 4		80	120	mA

† For test conditions shown as MIN or MAX, use the appropriate value specified under recommended operating conditions.

‡ All typical values are at $V_{CC} = 5 \text{ V}, T_A = 25^\circ\text{C}$.

§ Not more than one output should be shorted at a time.

- NOTES:
1. Voltage values are with respect to network ground terminal.
 2. An SN5497 in the W package operating at free-air temperatures above 118°C requires a heat sink that provides a thermal resistance from case to free-air, $R_{\theta CA}$, of not more than 55°C/W.
 3. I_{CCH} is measured with outputs open and all inputs grounded.
 4. I_{CCL} is measured with outputs open and all inputs at 4.5 V.

TYPES SN5497, SN7497 SYNCHRONOUS 6-BIT BINARY RATE MULTIPLIERS

switching characteristics, $V_{CC} = 5\text{ V}$, $T_A = 25^\circ\text{C}$, $N = 10$

PARAMETERS†	FROM INPUT	TO OUTPUT	TEST CONDITIONS	MIN	TYP	MAX	UNIT
f_{max}			$C_L = 15\text{ pF}$, $R_L = 400\ \Omega$, See Figure 1	25	32		MHz
t_{PLH}	Enable	Enable		13	20		ns
t_{PHL}				14	21		
t_{PLH}	Strobe	Z		12	18		ns
t_{PHL}				15	23		
t_{PLH}	Clock	Y		26	39		ns
t_{PHL}				20	30		
t_{PLH}	Clock	Z		12	18		ns
t_{PHL}				17	26		
t_{PLH}	Rate	Z		6	10		ns
t_{PHL}				9	14		
t_{PLH}	Unity/Cascade	Y		9	14		ns
t_{PHL}				6	10		
t_{PLH}	Strobe	Y		19	30		ns
t_{PHL}				22	33		
t_{PLH}	Clock	Enable		19	30		ns
t_{PHL}				22	33		
t_{PLH}	Clear	Y		24	36		ns
t_{PHL}		Z		15	23		
t_{PLH}	Any Rate Input	Y		15	23		ns
t_{PHL}			15	23			

† f_{max} = maximum clock frequency.

† t_{PLH} = propagation delay time, low-to-high-level output.

† t_{PHL} = propagation delay time, high-to-low-level output.

TYPICAL APPLICATION DATA

This application demonstrates how the '97 can be cascaded to perform 18-bit rate multiplication. This scheme is expandable to n-bits by extending the pattern illustrated.

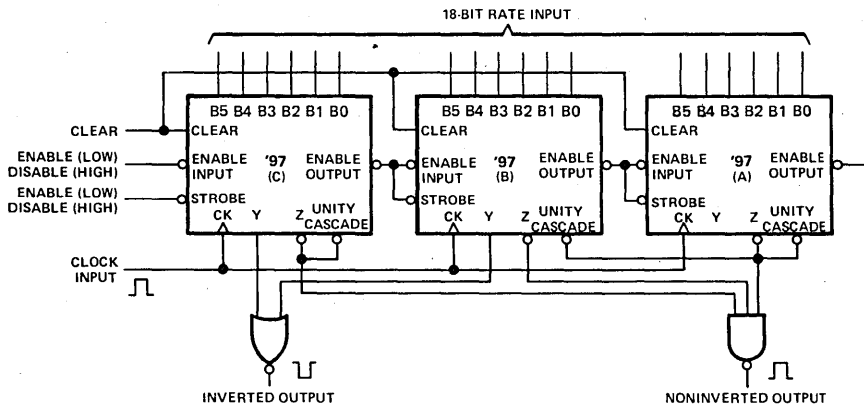

As illustrated, two of the 6-bit multipliers can be cascaded by connecting the Z output of unit A to the unity cascade input of unit B, in which case, a two-input NOR gate is used to cascade the remaining multipliers. Alternatively, all three Y outputs can be cascaded with a 3-input NOR gate. The three unused unity cascade inputs can be conveniently terminated by connecting each to its Z output.

3

TTL DEVICES

TEXAS
INSTRUMENTS

POST OFFICE BOX 225012 • DALLAS, TEXAS 75265

3-397

TYPES SN5497, SN7497
SYNCHRONOUS 6-BIT BINARY RATE MULTIPLIERS

PARAMETER MEASUREMENT INFORMATION

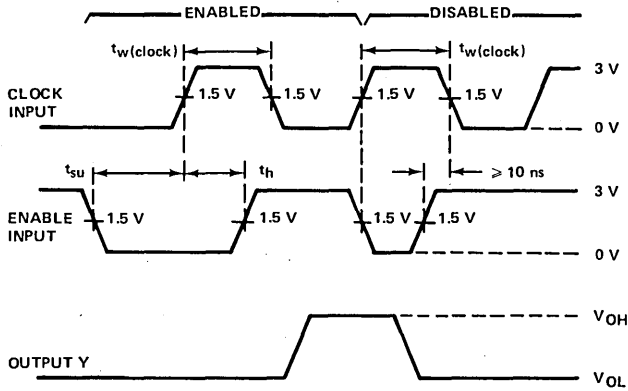

**ENABLING FROM POSITIVE-GOING
 TRANSITION OF CLOCK PULSE**

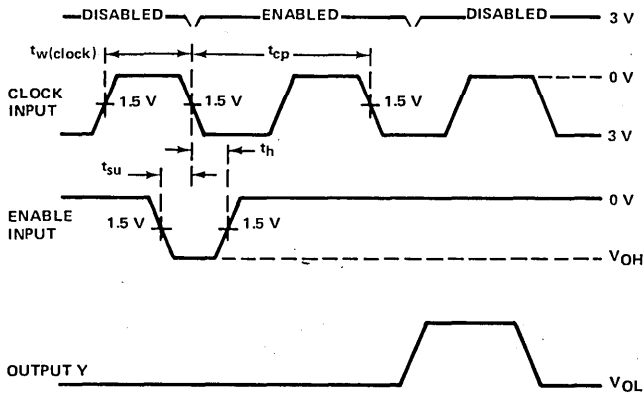

**ENABLING FROM NEGATIVE-GOING
 TRANSITION OF PREVIOUS CLOCK PULSE**

1. Unity/Cascade and pin 2 (rate input), other inputs are low. Clear the counter and apply clock and enable pulse as illustrated.
2. Setup and hold times are illustrated for enabling a single clock pulse (count). Continued application of the enable function will enable subsequent clock pulse (counts) until disabling occurs (enable goes high). The total number of counts will be determined by the total number of positive-going clock transition enabled.

NOTES: A. The input pulse generator has the following characteristics: $t_w(\text{clock}) = 20 \text{ ns}$, $t_{TLH} \leq 10 \text{ ns}$, $t_{THL} \leq 10 \text{ ns}$, $\text{PRR} = 1 \text{ MHz}$, $Z_{\text{out}} \approx 50 \Omega$.
 B. C_L includes probe and jig capacitance.
 C. All diodes are 1N3064 or equivalent.

FIGURE 1—SWITCHING TIMES

PARAMETER MEASUREMENT INFORMATION

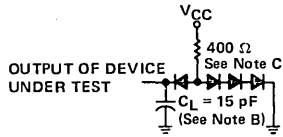

All three outputs are loaded during testing.
 LOAD CIRCUIT

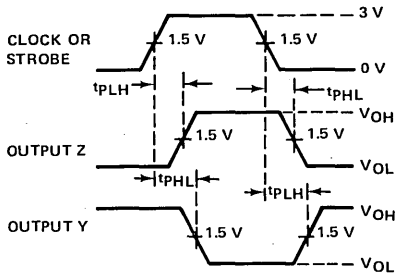

Unity/cascade and rate inputs are high, other inputs are low, and flip-flops are at any count other than maximum.

PROPAGATION DELAY TIMES, CLOCK TO Z AND Y,
 AND STROBE INPUT TO Z AND Y

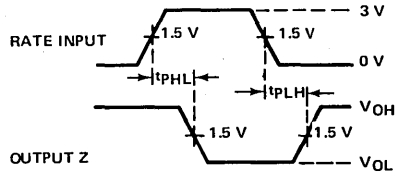

Flip-flops are at a count so that all other inputs to the gate under test are high and all other inputs, including other rate inputs, are low.

PROPAGATION DELAY TIMES,
 RATE INPUT TO Z

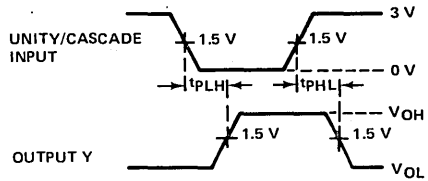

Output Z is high.

PROPAGATION DELAY TIMES,
 UNITY/CASCADE INPUT TO Y

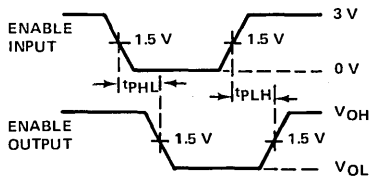

Flip-flops are at the maximum count. Other inputs are low.

PROPAGATION DELAY TIMES,
 ENABLE INPUT TO ENABLE OUTPUT

- NOTES: A. The input pulse generator has the following characteristics: $t_w(\text{clock}) = 20$ ns, $t_{TLH} \leq 10$ ns, $t_{THL} \leq 10$ ns, PRR = 1 MHz, $Z_{out} \approx 50 \Omega$.
 B. C_L includes probe and jig capacitance.
 C. All diodes are 1N3064 or equivalent.

FIGURE 1—SWITCHING TIMES (CONTINUED)

TYPE SN54L98 4-BIT DATA SELECTORS/STORAGE REGISTERS

DECEMBER 1972—REVISED DECEMBER 1983

- Dependable Texas Instruments Quality and Reliability

SN54L98 . . . J PACKAGE
(TOP VIEW)

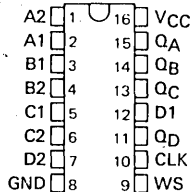

description

These monolithic data selectors/storage registers are composed of four S-R master-slave flip-flops, four AND-OR-INVERT gates, one buffer, and six inverter/drivers.

When the word select input is low, word 1 (A1, B1, C1, D1) is applied to the flip-flops. A high input to word select will cause the selection of word 2 (A2, B2, C2, D2). The selected word is shifted to the output terminals on the negative-going edge of the clock pulse.

Typical power dissipation is 25 mW. The SN54L98 is characterized for operation over the full military temperature range of -55°C to 125°C.

3 TTL DEVICES

logic diagram

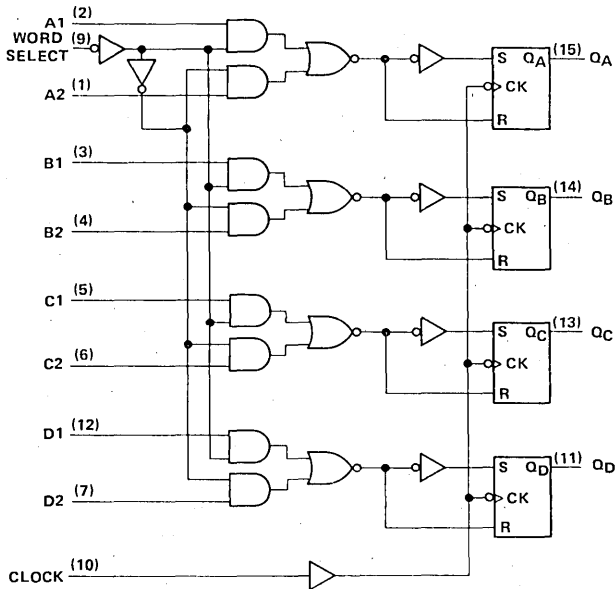

schematics of inputs and outputs

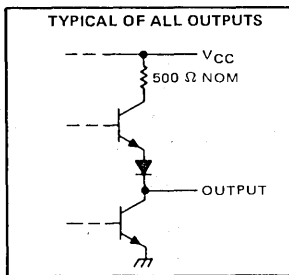
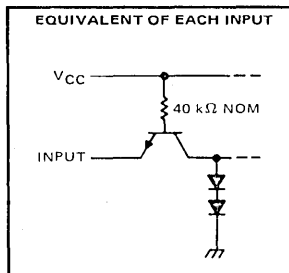

3-400

PRODUCTION DATA
This document contains information current as of publication date. Products conform to specifications per the terms of Texas Instruments standard warranty. Production processing does not necessarily include testing of all parameters.

TEXAS INSTRUMENTS

POST OFFICE BOX 225012 • DALLAS, TEXAS 75265

TYPE SN54L98 4-BIT DATA SELECTORS/STORAGE REGISTERS

absolute maximum ratings over operating free-air temperature range (unless otherwise noted)

Supply voltage, V_{CC} (see Note 1)	8 V
Input voltage (see Note 2)	5.5 V
Operating free-air temperature range: SN54L98	-55°C to 125°C
Storage temperature range	-65°C to 150°C

NOTES: 1. Voltage values are with respect to network ground terminal.
2. Input voltages must be zero or positive with respect to network ground terminal.

recommended operating conditions

		SN54L98			UNIT
		MIN	NOM	MAX	
V_{CC}	Supply voltage	4.5	5	5.5	V
V_{IH}	High-level input voltage	2			V
V_{IL}	Low-level input voltage			0.7	V
I_{OH}	High-level output current			-0.1	mA
I_{OL}	Low-level output current			2	mA
$t_w(\text{clock})$	Width of clock pulse	200			ns
$t_{su}(H)$	Setup time for high-level data	at A, B, C, or D		100	ns
		at word select		150	
$t_{su}(L)$	Setup time for low-level data	at A, B, C, or D		120	ns
		at word select		100	
T_A	Operating free-air temperature	-55		125	°C

electrical characteristics over recommended operating free-air temperature range (unless otherwise noted)

PARAMETER	TEST CONDITIONS†	SN54L98			UNIT
		MIN	TYP‡	MAX	
V_{OH}	$V_{CC} = \text{MIN}, V_{IH} = 2 \text{ V}, V_{IL} = 0.7 \text{ V}, I_{OH} = -0.1 \text{ mA}$	2.4	3.3		V
V_{OL}	$V_{CC} = \text{MIN}, V_{IH} = 2 \text{ V}, V_{IL} = 0.7 \text{ V}, I_{OL} = 2 \text{ mA}$		0.15	0.3	V
I_I	$V_{CC} = \text{MAX}, V_I = 5.5 \text{ V}$			0.1	mA
I_{IH}	$V_{CC} = \text{MAX}, V_I = 2.4 \text{ V}$			10	μA
I_{IL}	$V_{CC} = \text{MAX}, V_I = 0.3 \text{ V}$			-0.18	mA
$I_{OS} §$	$V_{CC} = \text{MAX}$	-3		-15	mA
I_{CC}	$V_{CC} = \text{MAX},$ See Note 3		5	9	mA

† For conditions shown as MIN or MAX, use the appropriate value specified under recommended operating conditions.

‡ All typical values are at $V_{CC} = 5 \text{ V}, T_A = 25^\circ\text{C}$.

§ Not more than one output should be shorted at a time.

NOTE 3: I_{CC} is measured with all inputs grounded and all outputs open.

switching characteristics, $V_{CC} = 5 \text{ V}, T_A = 25^\circ\text{C}$ (see note 4)

PARAMETER	FROM (INPUT)	TO (OUTPUT)	TEST CONDITIONS	MIN	TYP	MAX	UNIT	
f_{max}				3	5		MHz	
t_{PLH}	Any	Any	$R_L = 4 \text{ k}\Omega, C_L = 50 \text{ pF}$			115	200	ns
t_{PHL}						125	200	ns

NOTE 4: See General Information Section for load circuits and voltage waveforms.

3

TTL DEVICES



TYPE SN54L99 4-BIT RIGHT-SHIFT LEFT-SHIFT REGISTERS

DECEMBER 1972—REVISED DECEMBER 1983

- N-Bit Serial-to-Parallel Converter
- N-Bit Parallel-to-Serial Converter
- N-Bit Storage Register
- J-K̄ Serial Input

SN54L99 . . . J PACKAGE
(TOP VIEW)

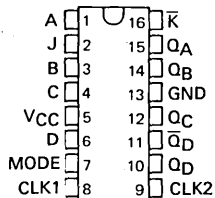

description

These 4-bit registers feature parallel inputs, parallel outputs, J-K̄ serial inputs, mode control, and two clock inputs. The registers have three modes of operation:

- Parallel (broadside) load
- Shift right (the direction Q_A toward Q_D)
- Shift left (the direction Q_D toward Q_A)

Parallel loading is accomplished by applying the four bits of data and taking the mode control input high. The data is loaded into the associated flip-flop and appears at the outputs after the high-to-low transition of the clock-2 input. During loading, the entry of serial data is inhibited.

Shift right is accomplished on a high-to-low transition of clock 1 when the mode control is low. Serial data for the right-shift mode is entered at the J-K̄ inputs. These inputs permit the first stage to perform as a J-K̄, a D-type, or T-type flip-flop as shown in the function table. Shift left is accomplished on the high-to-low transition of clock 2 when the mode control is high by connecting the output of each flip-flop to the parallel input of the previous flip-flop (Q_D to input C, etc.). Serial data for this mode is entered at the D input. The clock input may be applied commonly to clock 1 and clock 2 if both modes can be clocked from the same source. Changes at the mode control input should normally be made while both clock inputs are low; however, conditions described in the last three lines of the function table will also ensure that register contents are protected.

FUNCTION TABLE

		INPUTS								OUTPUTS				
MODE CONTROL	CLOCKS		SERIAL		PARALLEL				Q _A	Q _B	Q _C	Q _D	Q̄ _D	
	2 (L)	1 (R)	J	K̄	A	B	C	D						
H	H	X	X	X	X	X	X	X	Q _{A0}	Q _{B0}	Q _{C0}	Q _{D0}	Q̄ _{D0}	
H	↓	X	X	X	a	b	c	d	a	b	c	d	ā	
H	↓	X	X	X	Q _B †	Q _C †	Q _D †	d	Q _{Bn}	Q _{Cn}	Q _{Dn}	d	ā	
L	L	H	X	X	X	X	X	X	Q _{A0}	Q _{B0}	Q _{C0}	Q _{D0}	Q̄ _{D0}	
L	X	↓	L	H	X	X	X	X	Q _{A0}	Q _{A0}	Q _{Bn}	Q _{Cn}	Q̄ _{Cn}	
L	X	↓	L	L	X	X	X	X	L	Q _{An}	Q _{Bn}	Q _{Cn}	Q̄ _{Cn}	
L	X	↓	H	H	X	X	X	X	H	Q _{An}	Q _{Bn}	Q _{Cn}	Q̄ _{Cn}	
L	X	↓	H	L	X	X	X	X	Q̄ _{An}	Q _{An}	Q _{Bn}	Q _{Cn}	Q̄ _{Cn}	
↑	L	L	X	X	X	X	X	X	Q _{A0}	Q _{B0}	Q _{C0}	Q _{D0}	Q̄ _{D0}	
↓	L	L	X	X	X	X	X	X	Q _{A0}	Q _{B0}	Q _{C0}	Q _{D0}	Q̄ _{D0}	
↓	L	H	X	X	X	X	X	X	Q _{A0}	Q _{B0}	Q _{C0}	Q _{D0}	Q̄ _{D0}	
↑	H	L	X	X	X	X	X	X	Q _{A0}	Q _{B0}	Q _{C0}	Q _{D0}	Q̄ _{D0}	
↑	H	H	X	X	X	X	X	X	Q _{A0}	Q _{B0}	Q _{C0}	Q _{D0}	Q̄ _{D0}	

†Shifting left requires external connection of Q_B to A, Q_C to B, and Q_D to C. Serial data is entered at input D.

H = high level (steady state), L = low level (steady state)

X = irrelevant (any input, including transitions)

↓ = transition from high to low level, ↑ = transition from low to high level.

a, b, c, d = the level of steady-state input at inputs A, B, C, or D, respectively.

Q_{A0}, Q_{B0}, Q_{C0}, Q_{D0} = the level of Q_A, Q_B, Q_C, or Q_D, respectively, before the indicated steady-state input conditions were established.

Q_{An}, Q_{Bn}, Q_{Cn}, Q_{Dn} = the level of Q_A, Q_B, Q_C, or Q_D, respectively, before the most-recent ↓ transition of the clock.

PRODUCTION DATA

This document contains information current as of publication date. Products conform to specifications per the terms of Texas Instruments standard warranty. Production processing does not necessarily include testing of all parameters.

logic diagram

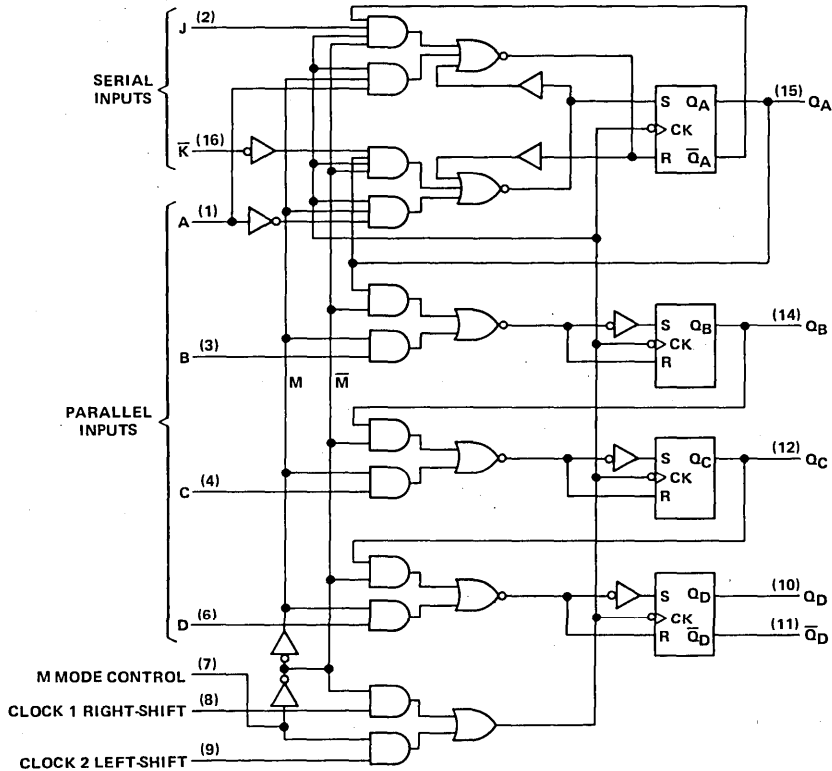

schematics of inputs and outputs

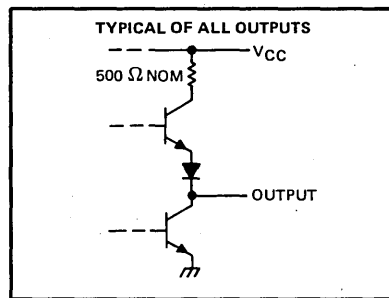
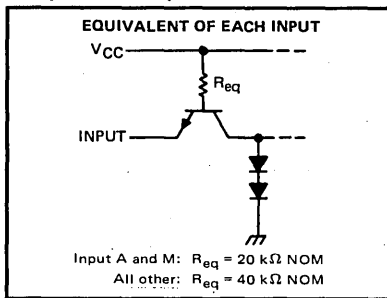

TYPE SN54L99

4-BIT RIGHT-SHIFT LEFT-SHIFT REGISTERS

absolute maximum ratings over operating free-air temperature range (unless otherwise noted)

Supply voltage, V_{CC} (see Note 1)	8 V
Input voltage (see Note 2)	5.5 V
Operating free-air temperature range	-55°C to 125°C
Storage temperature range	-65°C to 150°C

- NOTES: 1. Voltage values are with respect to network ground terminal.
 2. Input voltages must be zero or positive with respect to network ground terminal.

recommended operating conditions

		SN54L99			UNIT
		MIN	NOM	MAX	
V_{CC}	Supply voltage	4.5	5	5.5	V
V_{IH}	High-level input voltage	2			V
V_{IL}	Low-level input voltage			0.7	V
I_{OH}	High-level output current			-0.1	mA
I_{OL}	Low-level output current			2	mA
$t_{w(\text{clock})}$	Width of clock pulse	200			ns
$t_{su(H)}$	Setup time for high-level data at J, \bar{K} , A, B, C, or D inputs	100			ns
$t_{su(L)}$	Setup time for low-level data at J, \bar{K} , A, B, C, or D inputs	120			ns
t_h	Hold time at J, \bar{K} , A, B, C, or D inputs	0			ns
$t_{\text{enable 1}}$	Time to enable clock 1 (See Figure 1)	225			ns
$t_{\text{enable 2}}$	Time to enable clock 2 (See Figure 1)	200			ns
$t_{\text{inhibit 1}}$	Time to inhibit clock 1 (See Figure 1)	100			ns
$t_{\text{inhibit 2}}$	Time to inhibit clock 2 (See Figure 1)	0			ns
T_A	Operating free-air temperature	-55		125	°C

electrical characteristics over recommended operating free-air temperature range (unless otherwise noted)

PARAMETER	TEST CONDITIONS †	SN54L99			UNIT
		MIN	TYP ‡	MAX	
V_{OH}	$V_{CC} = \text{MIN}$, $V_{IH} = 2 \text{ V}$, $V_{IL} = 0.7 \text{ V}$, $I_{OH} = -0.1 \text{ mA}$	2.4	3.3		V
V_{OL}	$V_{CC} = \text{MIN}$, $V_{IH} = 2 \text{ V}$, $V_{IL} = 0.7 \text{ V}$, $I_{OL} = 2 \text{ mA}$	0.15	0.3		V
I_I	J, \bar{K} , B, C, or D			0.1	mA
	M or A	$V_{CC} = \text{MAX}$, $V_I = 5.5 \text{ V}$		0.2	
I_{IH}	J, \bar{K} , B, C, or D			10	µA
	M or A	$V_{CC} = \text{MAX}$, $V_I = 2.4 \text{ V}$		20	
I_{IL}	J, \bar{K} , B, C, or D			-0.18	mA
	M or A	$V_{CC} = \text{MAX}$, $V_I = 0.3 \text{ V}$		-0.36	
$I_{OS} §$	$V_{CC} = \text{MAX}$	-3		-15	mA
I_{CC}	$V_{CC} = \text{MAX}$, See Note 3		3.8	9	mA

† For conditions shown as MIN or MAX, use the appropriate value specified under recommended operating conditions for the applicable type.

‡ All typical values are at $V_{CC} = 5 \text{ V}$, $T_A = 25^\circ\text{C}$.

§ Not more than one output should be shorted at a time.

NOTE 3: With all outputs and J and \bar{K} inputs open, mode control at 4.5 V, inputs A through D grounded, I_{CC} is measured after a momentary 3 V, then ground is applied to both clock inputs.

switching characteristics, $V_{CC} = 5\text{ V}$, $T_A = 25^\circ\text{C}$

PARAMETER	FROM (INPUT)	TO (OUTPUT)	TEST CONDITIONS	MIN	TYP	MAX	UNIT
f_{max}	Any	Any	$R_L = 4\text{ k}\Omega$, $C_L = 50\text{ pF}$ See Figures 1 and 2	3	5		MHz
t_{PLH}				115	200		ns
t_{PHL}				125	200		ns

PARAMETER MEASUREMENT INFORMATION

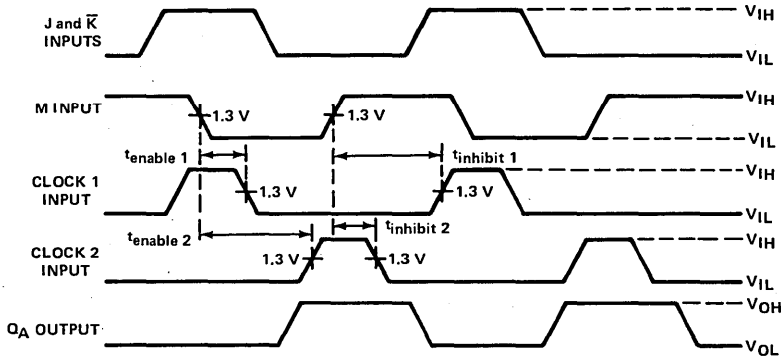
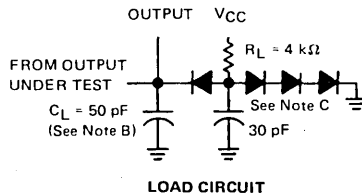

NOTE: A input is at the low level.

VOLTAGE WAVEFORMS
FIGURE 1—CLOCK ENABLE/INHIBIT TIMES

- NOTES:
- A. The input waveforms are supplied by pulse generators having the following characteristics: $Z_{\text{out}} \approx 50\ \Omega$. For data pulse generator: $t_w \geq 150\text{ ns}$, $\text{PRR} \leq 500\text{ kHz}$, $t_{\text{setup(L)}} = 120\text{ ns}$, and $t_{\text{setup(H)}} = 100\text{ ns}$. For clock pulse generator: $t_w \geq 200\text{ ns}$ and $\text{PRR} \leq 1\text{ MHz}$. When testing f_{max} , vary PRR.
 - B. C_L includes probe and jig capacitance.
 - C. All diodes are 1N3064 or equivalent.
 - D. When data input is applied to J and K inputs, the output waveform applies only to output Q_A .

**TYPE SN54L99
4-BIT RIGHT-SHIFT LEFT-SHIFT REGISTERS**

PARAMETER MEASUREMENT INFORMATION

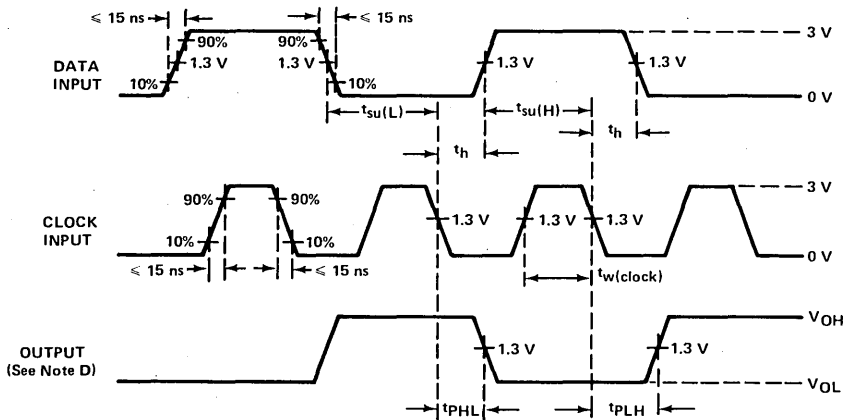

**VOLTAGE WAVEFORMS
FIGURE 2—SWITCHING TIMES**

- NOTES: A. The input waveforms are supplied by pulse generators having the following characteristics: $Z_{out} \approx 50 \Omega$. For data pulse generator: $t_w \geq 150$ ns, $PRR \leq 500$ kHz, $t_{setup(L)} = 120$ ns, and $t_{setup(H)} = 100$ ns. For clock pulse generator: $t_w \geq 200$ ns and $PRR \leq 1$ MHz. When testing f_{max} , vary PRR.
- B. C_L includes probe and jig capacitance.
- C. All diodes are 1N3064 or equivalent.
- D. When data input is applied to J and K inputs, the output waveform applies only to output Q_A .

3

TTL DEVICES

TYPES SN54100, SN74100 8-BIT BISTABLE LATCHES

DECEMBER 1972 - REVISED DECEMBER 1983

- Dependable Texas Instruments Quality and Reliability

SN54100 ... J OR W PACKAGE
SN74100 ... J OR N PACKAGE
(TOP VIEW)

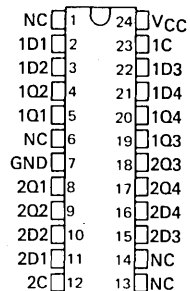

NC—No internal connection

FUNCTION TABLE
(Each Latch)

INPUTS		OUTPUTS	
D	G	Q	\bar{Q}
L	H	L	H
H	H	H	L
X	L	Q_0	\bar{Q}_0

H = high level, X = irrelevant
 Q_0 = the level of Q before the high-to-low transition of G

description

These latches are ideally suited for use as temporary storage for binary information between processing units and input/output or indicator units. Information present at a data (D) input is transferred to the Q output when the enable (G) is high and the Q output will follow the data input as long as the enable remains high. When the enable goes low, the information (that was setup at the data input at the time the transition occurred) is retained at the Q output until the enable is permitted to go high.

These circuits are completely compatible with all popular TTL families. All inputs are diode-clamped to minimize transmission-line effects and simplify system design. Typical power dissipation is 40 milliwatts per latch.

The SN54100 is characterized for operation over the full military temperature range of -55° to 125°C ; the SN74100 is characterized for operation from 0°C to 70°C .

logic diagram (each latch)

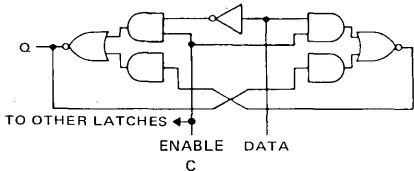

schematic (each latch)

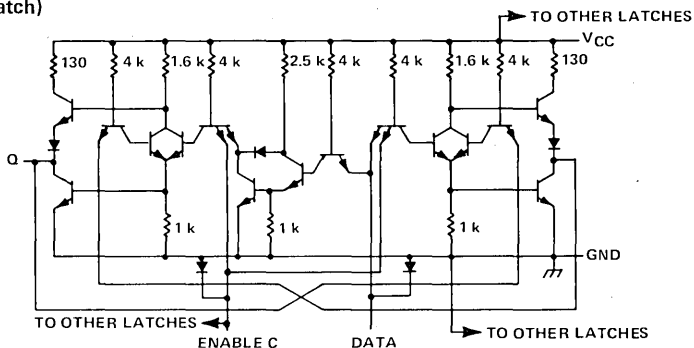

Resistor values shown are nominal and in ohms.

3

TTL DEVICES

TYPES SN54100, SN74100

8-BIT BISTABLE LATCHES

absolute maximum ratings over operating free-air temperature range (unless otherwise noted)

Supply voltage, V_{CC} (see Note 1)	7 V
Input voltage	5.5 V
Interemitter voltage (see Note 2)	5.5 V
Operating free-air temperature range: SN54100	-55°C to 125°C
SN74100	0°C to 70°C
Storage temperature range	-65°C to 150°C

- NOTES: 1. Voltage values, except interemitter voltage, are with respect to network ground terminal.
 2. This is the voltage between two emitters of a multiple-emitter input transistor. For this circuit, this rating applies between the enable and D inputs of any latch.

recommended operating conditions

	SN54100			SN74100			UNIT
	MIN	NOM	MAX	MIN	NOM	MAX	
Supply voltage, V_{CC}	4.5	5	5.5	4.75	5	5.25	V
High-level output current, I_{OH}			-400			-400	μ A
Low-level output current, I_{OL}			16			16	mA
Width of enabling pulse, t_w	20			20			ns
Setup time, t_{su}	20			20			ns
Hold time, t_h	5			5			ns
Operating free-air temperature, T_A	-55		125	0		70	°C

electrical characteristics over recommended operating free-air temperature range (unless otherwise noted)

PARAMETER		TEST CONDITIONS†		MIN	TYP‡	MAX	UNIT
V_{IH}	High-level input voltage			2			V
V_{IL}	Low-level input voltage				0.8		V
V_{IK}	Input clamp voltage	$V_{CC} = \text{MIN}$,	$I_I = -12 \text{ mA}$			-1.5	V
V_{OH}	High-level output voltage	$V_{CC} = \text{MIN}$,	$V_{IH} = 2 \text{ V}$, $V_{IL} = 0.8 \text{ V}$,	2.4	3.4		V
V_{OL}	Low-level output voltage	$V_{CC} = \text{MIN}$,	$V_{IH} = 2 \text{ V}$, $V_{IL} = 0.8 \text{ V}$,		0.2	0.4	V
I_I	Input current at maximum input voltage	$V_{CC} = \text{MAX}$,	$V_I = 5.5 \text{ V}$			1	mA
I_{IH}	High-level input current	D input	$V_{CC} = \text{MAX}$,	$V_I = 2.4 \text{ V}$		80	μ A
		C input			320		
I_{IL}	Low-level input current	D input	$V_{CC} = \text{MAX}$,	$V_I = 0.4 \text{ V}$		-3.2	mA
		C input			-12.8		
I_{OS}	Short-circuit output current§	$V_{CC} = \text{MAX}$	SN54100	-20		-57	mA
			SN74100	-18		-57	
I_{CC}	Supply current	$V_{CC} = \text{MAX}$, See Note 3	SN54100		64	92	mA
			SN74100		64	106	

† For conditions shown as MIN or MAX, use the appropriate value specified under recommended operating conditions.

‡ All typical values are at $V_{CC} = 5 \text{ V}$, $T_A = 25^\circ\text{C}$.

§ Not more than one output should be shorted at a time.

NOTE 3: I_{CC} is tested with all inputs grounded and all outputs open.

TYPES SN54100, SN74100
8-BIT BISTABLE LATCHES

switching characteristics, $V_{CC} = 5\text{ V}$, $T_A = 25^\circ\text{C}$

PARAMETER [†]	FROM (INPUT)	TO (OUTPUT)	TEST CONDITIONS	MIN	TYP	MAX	UNIT
t_{PLH}	D	Q	$C_L = 15\text{ pF}$, $R_L = 400\ \Omega$, See Note 4	16	30	ns	
t_{PHL}				14	25		
t_{PLH}	C	Q		16	30	ns	
t_{PHL}				7	15		

[†] t_{PLH} = propagation delay time, low-to-high-level output

[†] t_{PHL} = propagation delay time, high-to-low-level output

NOTE 4: Load circuits and voltage waveforms are the same as those shown for the '75, '77, 'L75, and 'L77.

TYPES SN54H101, SN74H101 AND-OR-GATED J-K NEGATIVE-EDGE-TRIGGERED FLIP-FLOPS WITH PRESET

REVISED DECEMBER 1983

- Package Options Include Plastic and Ceramic DIPs
- Dependable Texas Instruments Quality and Reliability

description

These monolithic J-K flip-flops are negative-edge-triggered. The AND-OR gate inputs are inhibited while the clock input is low; when the clock goes high, the inputs are enabled and data will be accepted. Logical state of J and K inputs may be allowed to change when the clock pulse is in a high state and bistable will perform according to the truth table as long as minimum set-up times are observed. Input data is transferred to the outputs on the negative edge of the clock pulse.

The SN54H101 is characterized for operation over the full military temperature range of -55°C to 125°C . The SN74H101 is characterized for operation from 0°C to 70°C .

FUNCTION TABLE

INPUTS				OUTPUTS	
PRE	CLK	J	K	Q	\bar{Q}
L	X	X	X	H	L
H	↓	L	L	Q_0	\bar{Q}_0
H	↓	H	L	H	L
H	↓	L	H	L	H
H	↓	H	H	TOGGLE	
H	H	X	X	Q_0	\bar{Q}_0

positive logic

$$J = (J1A \cdot J1B) + (J2A \cdot J2B)$$

$$K = (K1A \cdot K1B) + (K2A \cdot K2B)$$

SN54H101 . . . J PACKAGE
SN74H101 . . . J OR N PACKAGE
(TOP VIEW)

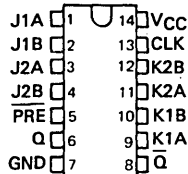

SN54H101 . . . W PACKAGE
(TOP VIEW)

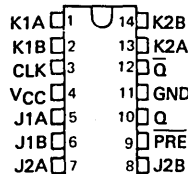

logic symbol

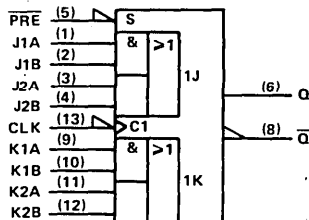

Pin numbers shown are for J and N packages.

TYPES SN54H101, SN74H101 AND-OR-GATED J-K NEGATIVE-EDGE-TRIGGERED FLIP-FLOPS WITH PRESET

recommended operating conditions

		SN54H101			SN74H101			UNIT
		MIN	NOM	MAX	MIN	NOM	MAX	
V _{CC}	Supply voltage	4.5	5	5.5	4.75	5	5.25	V
V _{IH}	High-level input voltage	2			2			V
V _{IL}	Low-level input voltage	0.8			0.8			V
I _{OH}	High-level output current	-0.5			-0.5			μA
I _{OL}	Low-level output current	20			20			mA
t _w	Pulse duration	CLK high	10		10		ns	
		CLK low	15		15			
		PRE low	16		16			
t _{su}	Setup time before CLK ↓	High-level data	10		10		ns	
		Low-level data	13		13			
t _h	Hold time-data after CLK ↓	0			0			ns
T _A	Operating free-air temperature	-55	125	0	70	°C		

electrical characteristics over recommended operating free-air temperature range (unless otherwise noted)

PARAMETER	TEST CONDITIONS†	SN54H101			SN74H101			UNIT
		MIN	TYP	MAX	MIN	TYP	MAX	
V _{IK}	V _{CC} = MIN, I _I = -8 mA	-1.5			-1.5			V
V _{OH}	V _{CC} = MIN, I _{OH} = -0.5 mA, V _{IH} = 2 V, V _{IL} = 0.8 V	2.4	3.4		2.4	3.4		V
V _{OL}	V _{CC} = MIN, I _{OL} = 20 mA, V _{IH} = 2 V, V _{IL} = 0.8 V		0.2	0.4		0.2	0.4	V
I _I	V _{CC} = MAX, V _I = 5.5 V		1			1		mA
I _{IH}	Any J or K		50			50		μA
	PRE	V _{CC} = MAX, V _I = 2.4 V	100		100			
	CLK		0	-1	0	-1		
I _{IL}	Any J or K	V _{CC} = MAX, V _I = 0.4 V	-1	-2	-1	-2	mA	
	PRE		-1	-2	-1	-2		
	CLK		-3	-4.8	-3	-4.8		
I _{OS} ‡	V _{CC} = MAX	-40	-100		-40	-100	mA	
I _{CC}	V _{CC} = MAX, See Note 2	20	38		20	38	mA	

† For conditions shown as MIN or MAX, use the appropriate value specified under recommended operating conditions

‡ All typical values are at V_{CC} = 5 V, T_A = 25°C.

§ Not more than one output should be shorted at a time, and duration of short-circuit should not exceed one second.

NOTE 2: With all outputs open, I_{CC} is measured with the Q and Q̄ outputs high in turn. At the time of measurement, the clock input is grounded.

switching characteristics, V_{CC} = 5 V, T_A = 25°C (see note 3)

PARAMETER	FROM (INPUT)	TO (OUTPUT)	TEST CONDITIONS	MIN	TYP	MAX	UNIT
f _{max}			R _L = 280 Ω, C _L = 25 pF	40	50		MHz
t _{PLH}	PRE	Q or Q̄		8	12		ns
t _{PHL}	PRE (CLK high)	Q̄ or Q		15	20		ns
	PRE (CLK low)			23	35		
t _{PLH}	CLK	Q or Q̄		10	15		ns
t _{PHL}				16	20		

NOTE 3: See General Information Section for load circuits and voltage waveforms.

TYPES SN54H102, SN74H102 AND-GATED J-K NEGATIVE-EDGE-TRIGGERED FLIP-FLOPS WITH PRESET AND CLEAR

REVISED DECEMBER 1983

- Package Options Include Plastic and Ceramic DIPs
- Dependable Texas Instruments Quality and Reliability

description

These monolithic J-K flip-flops are negative-edge-triggered. They feature gated J-K inputs and an asynchronous clear input. The AND gate inputs are inhibited while the clock input is low; when the clock goes high, the inputs are enabled and data will be accepted. Logical state of J and K inputs may be allowed to change when the clock pulse is in a high state and bistable will perform according to the truth table as long as minimum set-up times are observed. Input data is transferred to the outputs on the negative edge of the clock pulse.

The SN54H102 is characterized for operation over the full military temperature range of -55°C to 125°C . The SN74H102 is characterized for operation from 0°C to 70°C .

FUNCTION TABLE

INPUTS					OUTPUTS	
PRE	CLR	CLK	J	K	Q	\bar{Q}
L	H	X	X	X	H	L
H	L	X	X	X	L	H
L	L	X	X	X	H [†]	H [†]
H	H	↓	L	L	Q ₀	\bar{Q}_0
H	H	↓	H	L	H	L
H	H	↓	L	H	L	H
H	H	↓	H	H	TOGGLE	
H	H	H	X	X	Q ₀	\bar{Q}_0

† This configuration is nonstable; that is, it will not persist when preset and clear inputs return to their inactive (high) level.

positive logic

$$J = J1 \cdot J2 \cdot J3$$

$$K = K1 \cdot K2 \cdot K3$$

SN54H102 . . . J PACKAGE
SN74H102 . . . J OR N PACKAGE
(TOP VIEW)

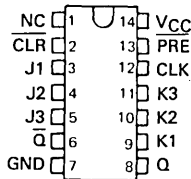

SN54H102 . . . W PACKAGE
(TOP VIEW)

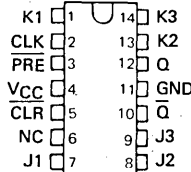

NC - No internal connection

logic symbol

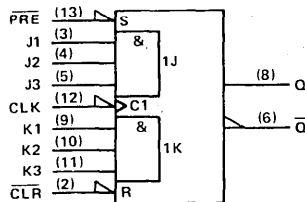

Pin numbers shown are for J and N packages.

PRODUCTION DATA
This document contains information current as of publication date. Products conform to specifications per the terms of Texas Instruments standard warranty. Production processing does not necessarily include testing of all parameters.

TEXAS
INSTRUMENTS

POST OFFICE BOX 225012 • DALLAS, TEXAS 75265

3-413

TTL DEVICES

TYPES SN54H102, SN74H102
AND-GATED J-K NEGATIVE-EDGE-TRIGGERED
FLIP-FLOPS WITH PRESET AND CLEAR

logic diagram

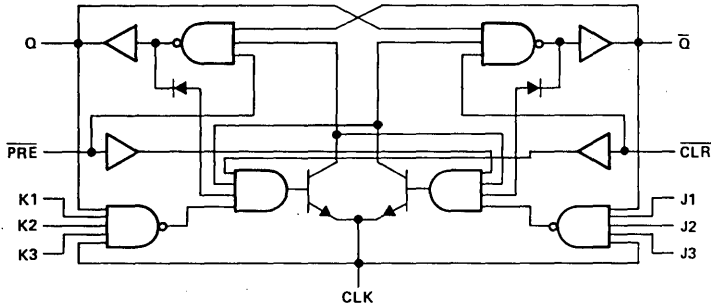

schematics of inputs and outputs

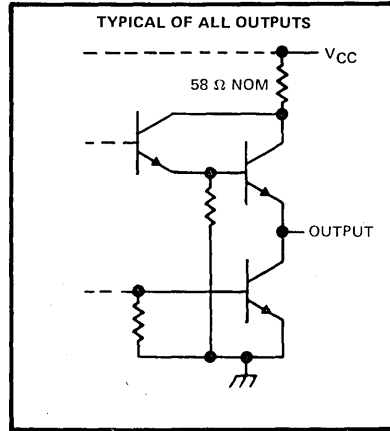
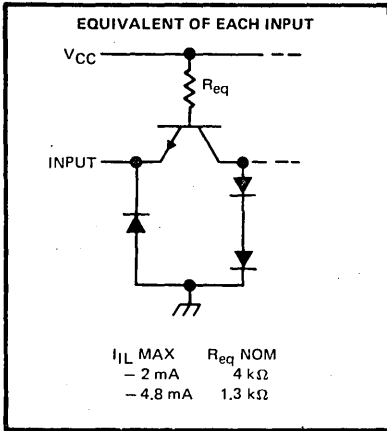

absolute maximum ratings over operating free-air temperature range (unless otherwise noted)

Supply voltage, V_{CC} (see Note 1)	7 V
Input voltage	5.5 V
Operating free-air temperature range: SN54H'	-55°C to 125°C
SN74H'	0°C to 70°C
Storage temperature range	-65°C to 150°C

NOTE 1: Voltage values are with respect to network ground terminal.

TYPES SN54H102, SN74H102 AND-GATED J-K NEGATIVE-EDGE-TRIGGERED FLIP-FLOPS WITH PRESET AND CLEAR

recommended operating conditions

		SN54H102			SN74H102			UNIT	
		MIN	NOM	MAX	MIN	NOM	MAX		
V _{CC}	Supply voltage	4.5	5	5.5	4.75	5	5.25	V	
V _{IH}	High-level input voltage	2			2			V	
V _{IL}	Low-level input voltage	0.8			0.8			V	
I _{OH}	High-level output current	-0.5			-0.5			mA	
I _{OL}	Low-level output current	20			20			mA	
t _w	Pulse duration	CLK high	10		10		ns		
		CLK low	15		15				
		CLR or PRE low	16		16				
t _{su}	Setup time before CLK ↓	High-level data	10		10		ns		
		Low-level data	13		13				
t _h	Hold time-data after CLK ↓	0			0			ns	
T _A	Operating free-air temperature	-55		125		0		70	°C

electrical characteristics over recommended operating free-air temperature range (unless otherwise noted)

PARAMETER		TEST CONDITIONS†		SN54H102		SN74H102		UNIT
				MIN	TYP‡	MAX	MIN	
V _{IK}		V _{CC} = MIN, I _I = -8 mA		-1.5		-1.5		V
V _{OH}		V _{CC} = MIN, V _{IH} = 2 V, V _{IL} = 0.8 V, I _{OH} = -0.5 mA		2.4	3.4	2.4	3.4	V
V _{OL}		V _{CC} = MIN, V _{IH} = 2 V, V _{IL} = 0.8 V, I _{OL} = 20 mA		0.2	0.4	0.2	0.4	V
I _I		V _{CC} = MAX, V _I = 5.5 V		1		1		mA
I _{IH}	Any J or K	V _{CC} = MAX, V _I = 2.4 V		50		50		μA
	CLR			100		100		
	PRE			100		100		
	CLK			0		-1		
I _{IL}	Any J or K	V _{CC} = MAX, V _I = 0.4 V		-1		-1		mA
	CLR			-1		-1		
	PRE			-1		-1		
	CLK			-3		-4.8		
I _{OS} §		V _{CC} = MAX		-40	-100	-40	-100	mA
I _{CC}		V _{CC} = MAX, See Note 2		20	38	20	38	mA

† For conditions shown as MIN or MAX, use the appropriate value specified under recommended operating conditions.

‡ All typical values are at V_{CC} = 5 V, T_A = 25°C.

§ Not more than one output should be shorted at a time, and duration of short-circuit should not exceed one second.

NOTE 2: With all outputs open, I_{CC} is measured with the Q and \bar{Q} outputs high in turn. At the time of measurement, the clock input is grounded.

switching characteristics, V_{CC} = 5 V, T_A = 25°C (see note 3)

PARAMETER	FROM (INPUT)	TO (OUTPUT)	TEST CONDITIONS	MIN	TYP	MAX	UNIT
f _{max}			R _L = 280 Ω, C _L = 25 pF	40	50		MHz
t _{PLH}	PRE or CLR	Q or \bar{Q}			8	12	ns
t _{PHL}	PRE or CLR (CLK high)	\bar{Q} or Q			15	20	ns
	PRE or CLR (CLK low)				23	35	
t _{PLH}	CLK	Q or \bar{Q}			10	15	ns
t _{PHL}					16	20	

NOTE 3: See General Information Section for load circuits and voltage waveforms.

**TEXAS
INSTRUMENTS**

POST OFFICE BOX 225012 • DALLAS, TEXAS 75265

3

TTL DEVICES

TYPES SN54H103, SN74H103 DUAL J-K NEGATIVE-EDGE-TRIGGERED FLIP-FLOPS WITH CLEAR

REVISED DECEMBER 1983

- Package Options Include Plastic and Ceramic DIPs
- Dependable Texas Instruments Quality and Reliability

description

These dual monolithic J-K flip-flops are negative-edge-triggered. They feature individual J, K, clock, and asynchronous clear inputs to each flip-flop. When the clock goes high, the inputs are enabled and data will be accepted. Logical state of J and K inputs may be allowed to change when the clock pulse is in a high state and bistable will perform according to the truth table as long minimum set-up times are observed. Input data is transferred to the outputs on the negative edge of the clock pulse.

The SN54H103 is characterized for operation over the full military temperature range of -55°C to 125°C . The SN74H103 is characterized for operation from 0° to 70°C .

SN54H103 ... J OR W PACKAGE
SN74H103 ... J OR N PACKAGE
(TOP VIEW)

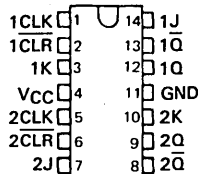

logic symbol

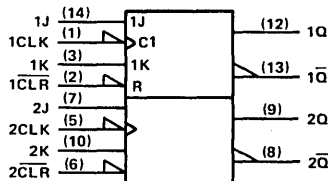

Pin numbers shown are for J and N packages.

FUNCTION TABLE

INPUTS				OUTPUTS	
CLR	CLK	J	K	Q	Q̄
L	X	X	X	L	H
H	↓	L	L	Q ₀	Q̄ ₀
H	↓	H	L	H	L
H	↓	L	H	L	H
H	↓	H	H	TOGGLE	
H	H	X	X	Q ₀	Q̄ ₀

3

TTL DEVICES

PRODUCTION DATA

This document contains information current as of publication date. Products conform to specifications per the terms of Texas Instruments standard warranty. Production processing does not necessarily include testing of all parameters.

TEXAS
INSTRUMENTS

POST OFFICE BOX 225012 • DALLAS, TEXAS 75265

TYPES SN54H103, SN74H103
 DUAL J-K NEGATIVE-EDGE-TRIGGERED
 FLIP-FLOPS WITH CLEAR

logic diagram

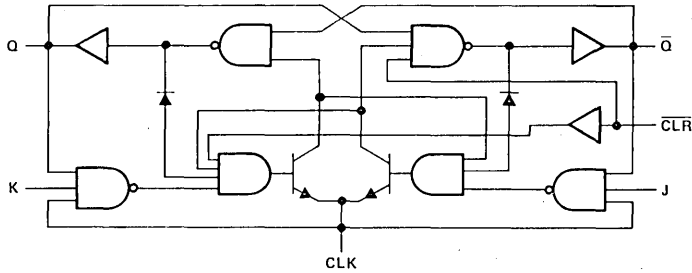

schematics of inputs and outputs

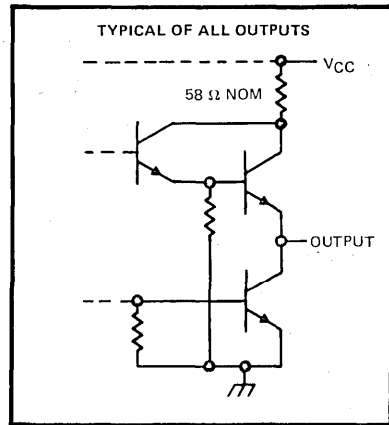
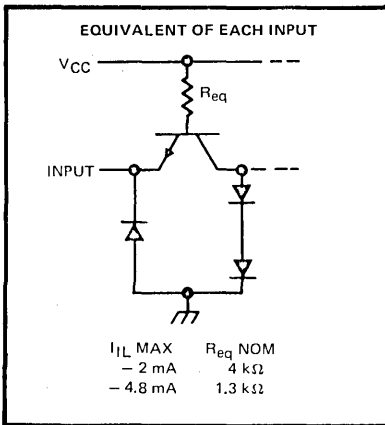

absolute maximum ratings over operating free-air temperature range (unless otherwise noted)

Supply voltage, V_{CC} (see Note 1)	7 V
Input voltage	5.5 V
Operating free-air temperature range: SN54H'	-55°C to 125°C
SN74H'	0°C to 70°C
Storage temperature range	-65°C to 150°C

NOTE 1: Voltage values are with respect to network ground terminal.



TTL DEVICES

TYPES SN54H103; SN74H103

DUAL J-K NEGATIVE-EDGE-TRIGGERED FLIP-FLOPS WITH CLEAR

recommended operating conditions

	SN54H103			SN74H103			UNIT
	MIN	NOM	MAX	MIN	NOM	MAX	
V _{CC} Supply voltage	4.5	5	5.5	4.75	5	5.25	V
V _{IH} High-level input voltage	2			2			V
V _{IL} Low-level input voltage			0.8			0.8	V
I _{OH} Low-level output current			-0.5			-0.5	μA
I _{OL} Low-level output current			20			20	mA
t _w Pulse duration	CLK high	10		10			ns
	CLK low	15		15			
	CLR low	16		16			
t _{su} Setup time before CLK ↓	High-level data	10		10			ns
	Low-level data	13		13			
t _h Hold time-data after CLK ↓		0		0			ns
T _A Operating free-air temperature	-55		125	0		70	°C

electrical characteristics over recommended operating free-air temperature range (unless otherwise noted)

PARAMETER	TEST CONDITIONS†	SN54H103		SN74H103		UNIT	
		MIN	TYP‡	MAX	MIN		TYP‡
V _{IK}	V _{CC} = MIN, I _I = -8 mA			-1.5		-1.5	V
V _{OH}	V _{CC} = MIN, V _{IH} = 2 V, V _{IL} = 0.8 V, I _{OH} = -0.5 mA	2.4	3.4	2.4	3.4		V
V _{OL}	V _{CC} = MIN, V _{IH} = 2 V, V _{IL} = 0.8 V, I _{OL} = 20 mA	0.2	0.4	0.2	0.4		V
I _I	V _{CC} = MAX, V _I = 5.5 V		1		1		mA
I _{IH}	Any J or K		50		50		μA
	CLR	V _{CC} = MAX, V _I = 2.4 V	100		100		
	CLK		0	-1	0	-1	
I _{IL}	Any J or K		-1	-2		-1	mA
	CLR	V _{CC} = MAX, V _I = 0.4 V	-1	-2		-1	
	CLK		-3	-4.8		-3	
I _{OS} §	V _{CC} = MAX	-40	-100	-40	-100		mA
I _{CC}	V _{CC} = MAX, See Note 2	20	38	20	38		mA

† For conditions shown as MIN or MAX, use the appropriate value specified under recommended operating conditions.

‡ All typical values are at V_{CC} = 5 V, T_A = 25°C.

§ Not more than one output should be shorted at a time, and duration of short-circuit should not exceed one second.

NOTE 2: With all outputs open, I_{CC} is measured with the Q and Q outputs high in turn. At the time of measurement, the clock input is grounded.

switching characteristics, V_{CC} = 5 V, T_A = 25°C (see note 3)

PARAMETER	FROM (INPUT)	TO (OUTPUT)	TEST CONDITIONS	MIN	TYP	MAX	UNIT
f _{max}				40	50		MHz
t _{PLH}	CLR	Q or Q̄	R _L = 280 Ω, C _L = 25 pF	8	12		ns
t _{PHL}	CLR (CLK high)	Q̄ or Q		15	20		ns
	CLR (CLK low)			23	35		
t _{PLH}	CLK	Q or Q̄		10	15		ns
t _{PHL}			16	20			

NOTE 3: See General Information Section for load circuits and voltage waveforms.

TYPES SN54104, SN54105, SN74104, SN74105 GATED J-K MASTER-SLAVE FLIP-FLOPS

REVISED DECEMBER 1983

- Buffered Clock Input
- Direct Preset and Clear
- Common JK Gate Input

logic

FUNCTION TABLE

INPUT AT t_n			OUTPUT AT t_{n+1}	
JK	J^{\dagger}	K^{\dagger}	Q	\bar{Q}
L \dagger	X	X	Q_n	\bar{Q}_n
H	L \dagger	L \dagger	Q_n	\bar{Q}_n
H	L	H	L	H
H	H	L	H	L
H	H	H	\bar{Q}_n	Q_n

† SN54104/SN74104J = $J1 \cdot J2 \cdot J3$.

$K = K1 \cdot K2 \cdot K3$

SN54105/SN74105J = $J1 \cdot \bar{J2} \cdot J3$.

$K = K1 \cdot K2 \cdot K3$

‡ These low-levels must be maintained while the clock is low.

NOTES:

- t_n = bit time before clock pulse
- t_{n+1} = bit time after clock pulse
- H = high, L = low, X = irrelevant

SN54104 ... J OR W PACKAGE
SN74104 ... J OR N PACKAGE

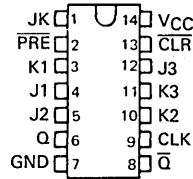

SN54105 ... J OR W PACKAGE
SN74105 ... J OR N PACKAGE

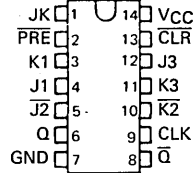

description

These J-K master-slave flip-flops feature a buffered clock input, direct preset and clear, gated J and K inputs, and a common JK input. The clock buffer offers typical TTL high noise immunity, low clock-line loading, and, in most cases, eliminates the need for stringent control of system-clock rise and fall times. When activated, the direct preset and clear inputs control the state of both the master and slave flip-flops independent of the clock and synchronous-input states. Gated inputs may be used to perform a wide variety of control functions without the need for external gates, and the common JK input simplifies hardware design for applications utilizing a single gate-control source.

Due to the internal clock buffer, the JK input gates accept data when the clock line is low, and transfer of data from the master to the slave occurs during the clock-line transition from the low state to the high state. When the clock line is high, the data inputs are inhibited.

The SN54104/SN74104 includes internal capacitive loading on the J and K input gates and, as the input setup and hold times are lengthened, this circuit displays improved performance in systems where appreciable clock skew is anticipated.

The SN54105/SN74105 offers an inverting data input to each of the J and K input gates for additional control flexibility. As the input setup and hold times are not lengthened, this circuit permits operation at higher toggle rates than the SN54104/SN74104.

These TTL circuits feature one-volt typical d-c noise margins and are compatible for use with most TTL families. Full fan-out to 10 normalized Series 54/74 loads is available from the outputs. The SN54104 and SN54105 circuits are characterized for operation over the full military temperature range of -55°C to 125°C , and the SN74104 and SN74105 circuits are characterized for operation from 0°C to 70°C .

PRODUCTION DATA

This document contains information current as of publication date. Products conform to specifications per the terms of Texas Instruments standard warranty. Production processing does not necessarily include testing of all parameters.



POST OFFICE BOX 225012 • DALLAS, TEXAS 75265

TYPES SN54104, SN54105, SN74104, SN74105 GATED J-K MASTER-SLAVE FLIP-FLOPS

logic diagrams

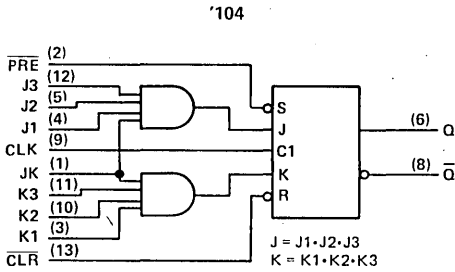

Pin numbers shown on logic notation are for J or N packages.

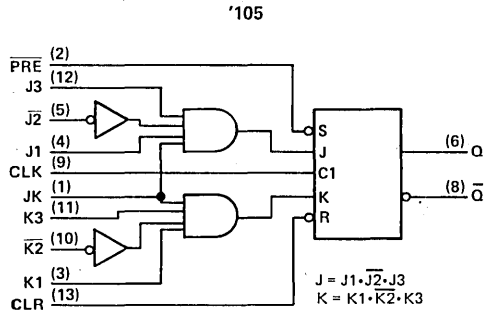

absolute maximum ratings over operating free-air temperature range (unless otherwise noted)

Supply voltage, V_{CC} (See Note 1)	8 V
Input voltage	5.5 V
Voltage applied to any output (See Note 2)	5.5 V
Operating free-air temperature range: SN54104, SN54105 Circuits	-55°C to 125°C
SN74104, SN74105 Circuits	0°C to 70°C
Storage temperature range	-65°C to 150°C

recommended operating conditions

	SN54'			SN74'			UNIT
	MIN	NOM	MAX	MIN	NOM	MAX	
V_{CC} Supply voltage (see Note 1)	4.5	5	5.5	4.75	5	5.25	V
V_{IH} High-level input voltage	2			2			V
V_{IL} Low-level input voltage	0.8			0.8			V
I_{OH} High-level output current	-1			-1			mA
I_{OL} Low-level output current	16			16			mA
t_w Pulse duration	CLK Low-level	15 [†]		15 [†]		ns	
	PRE and CLR	20 [†]		20 [†]			
t_{su} Setup time for high-level data (See Note 4)	'104	35 [†]		35 [†]		ns	
	'105	10 [†]		10 [†]			
t_r Release time for low-level data (See Note 3)	'104	10 [†]		10 [†]		ns	
	'105	1 [†]		1 [†]			
T_A Operating free-air temperature	-55		125	0		70	°C

[†] These conditions are recommended at $V_{CC} = 5$ V, $T_A = 25^\circ$ C.

NOTES: 1. Voltage values are with respect to network ground terminal.

2. This rating applied at the Q output with preset held low and at the \bar{Q} output with clear held low.

3. Release time for low-level data is an interval between the release of low-level data and the positive-going edge of the clock pulse; this interval being sufficiently short to ensure recognition of the low-level data.

4. Setup time for high-level data is an interval between the arrival of the high-level data and the positive-going edge of the clock pulse; this interval being sufficiently long to ensure recognition of the high-level data.

TYPES SN54104, SN54105, SN74104, SN74105
GATED J-K MASTER-SLAVE FLIP-FLOPS

electrical characteristics over recommended operating free-air temperature range (unless otherwise noted)

PARAMETER		TEST CONDITIONS†	MIN	TYP‡	MAX	UNIT
V _{OH}		V _{CC} = MIN, I _{OH} = -1 mA	2.4	2.7		V
V _{OL}		V _{CC} = MIN, I _{OL} = 16 mA		0.2	0.4	V
I _{IH}	PRE or CLR	V _{CC} = MAX, V _I = 4.5 V		8	120	μA
	J or K			4	80	
	All other			2	40	
I _{IL}	PRE or CLR	V _{CC} = MAX, V _I = 0.4 V		-3	-4.75	mA
	J or K			-2.2	-3.2	
	All other			-1.1	-1.6	
I _{CC}	'104	V _{CC} = 5 V		15	24	mA
	'105			17	28	

† For conditions shown as MIN or MAX, use appropriate value specified under recommended operating conditions for the applicable device type.

‡ All typical values are at V_{CC} = 5 V, T_A = 25°C.

switching characteristics, V_{CC} = 5 V, T_A = 25°C (see note 5)

PARAMETER	FROM (INPUT)	TO (OUTPUT)	TEST CONDITIONS		MIN	TYP	MAX	UNIT
t _{PLH}	CLK	Q or Q̄	R _L = 400 Ω,	C _L = 15 pF		9	15	ns
t _{PHL}						16	25	

NOTE 5: See General Information Section for load circuits and voltage waveforms.

TYPES SN54H106, SN74H106 DUAL J-K NEGATIVE-EDGE-TRIGGERED FLIP-FLOPS WITH PRESET AND CLEAR

REVISED DECEMBER 1983

- Package Options Include Plastic and Ceramic DIPs
- Dependable Texas Instruments Quality and Reliability

description

These dual monolithic J-K flip-flops are negative-edge-triggered. They feature individual J, K, clock, and asynchronous preset and clear inputs to each flip-flop. When the clock goes high, the inputs are enabled and data will be accepted. Logical state of J and K inputs may be allowed to change when the clock pulse is in a high state and bistable will perform according to the truth table as long as minimum set-up times are observed. Input data is transferred to the outputs on the negative edge of the clock pulse.

The SN54H106 is characterized for operation over the full military temperature range of -55°C to 125°C . The SN74H106 is characterized for operation from 0°C to 70°C .

SN54H106 . . . J OR W PACKAGE
SN74H106 . . . J OR N PACKAGE
(TOP VIEW)

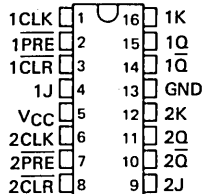

logic symbol

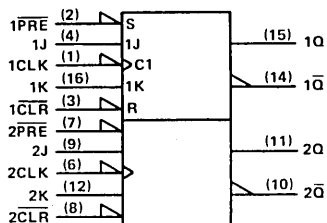

Pin numbers shown are for J and N packages.

FUNCTION TABLE

INPUTS					OUTPUTS	
PRE	CLR	CLK	J	K	Q	Q̄
L	H	X	X	X	H	L
H	L	X	X	X	L	H
L	L	X	X	X	H†	H†
H	H	↓	L	L	Q _O	Q̄ _O
H	H	↓	H	L	H	L
H	H	↓	L	H	L	H
H	H	↓	H	H	TOGGLE	TOGGLE
H	H	H	X	X	Q _O	Q̄ _O

† This configuration is nonstable; that is, it will not persist when preset and clear inputs return to their inactive (high) level.

PRODUCTION DATA

This document contains information current as of publication date. Products conform to specifications per the terms of Texas Instruments standard warranty. Production processing does not necessarily include testing of all parameters.

TYPES SN54H106, SN74H106
 DUAL J-K NEGATIVE-EDGE-TRIGGERED
 FLIP-FLOPS WITH PRESET AND CLEAR

logic diagram

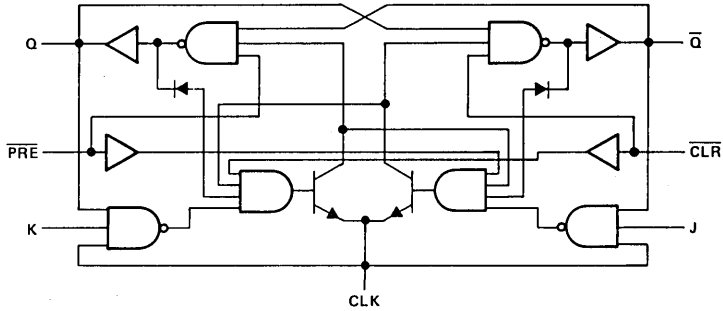

schematics of inputs and outputs

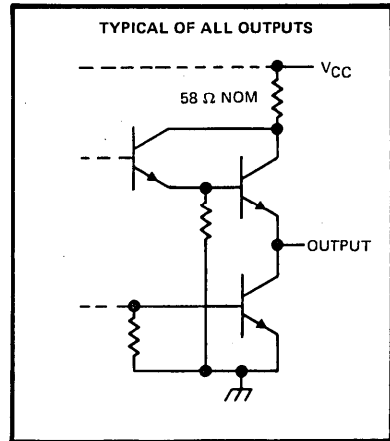
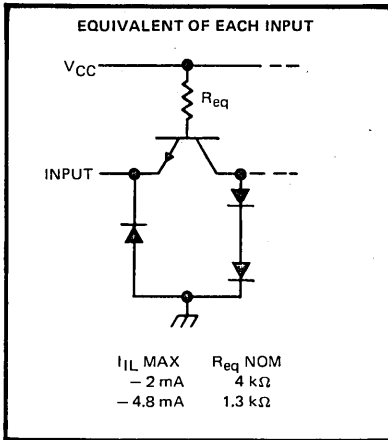

absolute maximum ratings over operating free-air temperature range (unless otherwise noted)

Supply voltage, V_{CC} (see Note 1)	7 V
Input voltage	5.5 V
Operating free-air temperature range: SN54H [†]	-55°C to 125°C
SN74H [†]	0°C to 70°C
Storage temperature range	-65°C to 150°C

NOTE 1: Voltage values are with respect to network ground terminal.

TTL DEVICES 3

TYPES SN54H106, SN74H106 DUAL J-K NEGATIVE-EDGE-TRIGGERED FLIP-FLOPS WITH PRESET AND CLEAR

recommended operating conditions

		SN54H106			SN74H106			UNIT
		MIN	NOM	MAX	MIN	NOM	MAX	
V _{CC}	Supply voltage	4.5	5	5.5	4.75	5	5.25	V
V _{IH}	High-level input voltage	2			2			V
V _{IL}	Low-level input voltage	0.8			0.8			V
I _{OH}	High-level output current	-0.5			-0.5			mA
I _{OL}	Low-level output current	20			20			mA
t _w	Pulse duration	CLK high		10	10		ns	
		CLK low		15	15			
		CLR or PRE low		16	16			
t _{su}	Setup time before CLK ↓	High-level data		10	10		ns	
		Low-level data		13	13			
t _h	Hold time data after CLK ↓	0			0			ns
T _A	Operating free-air temperature	-55		125	0		70	°C

electrical characteristics over recommended operating free-air temperature range (unless otherwise noted)

PARAMETER	TEST CONDITIONS†	SN54H106			SN74H106			UNIT
		MIN	TYP‡	MAX	MIN	TYP‡	MAX	
V _{IK}	V _{CC} = MIN, I _I = -8 mA	-1.5			-1.5			V
V _{OH}	V _{CC} = MIN, V _{IH} = 2 V, V _{IL} = 0.8 V, I _{OH} = -0.5 mA	2.4	3.4		2.4	3.4	V	
V _{OL}	V _{CC} = MIN, V _{IH} = 2 V, V _{IL} = 0.8 V, I _{OL} = 20 mA	0.2	0.4		0.2	0.4	V	
I _I	V _{CC} = MAX, V _I = 5.5 V	1			1			mA
I _{IH}	Any J or K	50			50			μA
	CLR	100			100			
	PRE	100			100			
	CLK	0			-1			
I _{IL}	Any J or K	-1			-1			mA
	CLR	-1			-1			
	PRE	-1			-1			
	CLK	-3			-4.8			
I _{OS} §	V _{CC} = MAX	-40	-100		-40	-100	mA	
I _{CC}	V _{CC} = MAX, See Note 2	20	38		20	38	mA	

† For conditions shown as MIN or MAX, use the appropriate value specified under recommended operating conditions.

‡ All typical values are at V_{CC} = 5 V, T_A = 25°C.

§ Not more than one output should be shorted at a time, and duration of short-circuit should not exceed one second.

NOTE 2: With all output open, I_{CC} is measured with the Q and Q̄ outputs high in turn. At the time of measurement, the clock input is grounded.

switching characteristics, V_{CC} = 5 V, T_A = 25°C (see note 3)

PARAMETER	FROM (INPUT)	TO (OUTPUT)	TEST CONDITIONS	MIN	TYP	MAX	UNIT
f _{max}				40	50		MHz
t _{PLH}	PRE or CLR	Q or Q̄	R _L = 280 Ω, C _L = 25 pF	8		12	ns
t _{PHL}	PRE or CLR (CLK high)	Q̄ or Q		15		20	ns
	PRE or CLR (CLK low)			23		35	
t _{PLH}	CLK	Q or Q̄		10		15	ns
t _{PHL}				16		20	

NOTE 3: See General Information Section for load circuits and voltage waveforms.

**TYPES SN54107, SN54LS107A,
SN74107, SN74LS107A**
DUAL J-K FLIP-FLOPS WITH CLEAR
REVISED DECEMBER 1983

- Package Options Include Both Plastic and Ceramic Chip Carriers in Addition to Plastic and Ceramic DIPs
- Dependable Texas Instruments Quality and Reliability

description

The '107 contain two independent J-K flip-flops with individual J-K, clock, and direct clear inputs. The '107 is a positive pulse-triggered flip-flop. The J-K input is loaded into the master while the clock is high and transferred to the slave on the high-to-low clock transition. For these devices the J and K inputs must be stable while the clock is high.

The 'LS107A contain two independent negative-edge-triggered flip-flops. The J and K inputs must be stable one setup time prior to the high-to-low clock transition for predictable operation. When the clear is low, it overrides the clock and data inputs forcing the Q output low and the \bar{Q} output high.

The SN54107 and the SN54LS107A are characterized for operation over the full military temperature range of -55°C to 125°C. The SN74107 and the SN74LS107A are characterized for operation from 0°C to 70°C.

SN54107, SN54LS107A ... J PACKAGE
SN74107 ... J OR N PACKAGE
SN74LS107A ... D, J OR N PACKAGE
(TOP VIEW)

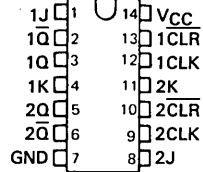

SN54LS107A ... FK PACKAGE
SN74LS107A ... FN PACKAGE
(TOP VIEW)

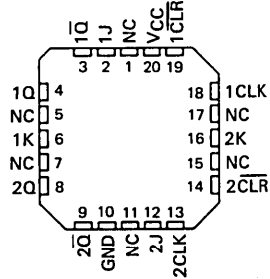

NC - No internal connection

'107
FUNCTION TABLE

INPUTS				OUTPUTS	
CLR	CLK	J	K	Q	\bar{Q}
L	X	X	X	L	H
H	\downarrow	L	L	Q_0	\bar{Q}_0
H	\downarrow	H	L	H	L
H	\downarrow	L	H	L	H
H	\downarrow	H	H	TOGGLE	

'LS107A
FUNCTION TABLE

INPUTS				OUTPUTS	
CLR	CLK	J	K	Q	\bar{Q}
L	X	X	X	L	H
H	\downarrow	L	L	Q_0	\bar{Q}_0
H	\downarrow	H	L	H	L
H	\downarrow	L	H	L	H
H	\downarrow	H	H	TOGGLE	
H	H	X	X	Q_0	\bar{Q}_0

PRODUCTION DATA
This document contains information current as of publication date. Products conform to specifications per the terms of Texas Instruments standard warranty. Production processing does not necessarily include testing of all parameters.



POST OFFICE BOX 225012 • DALLAS, TEXAS 75265

3
TTL DEVICES

TYPES SN54107, SN54LS107A,
 SN74107, SN74LS107A
 DUAL J-K FLIP-FLOPS WITH CLEAR

logic diagrams

'107

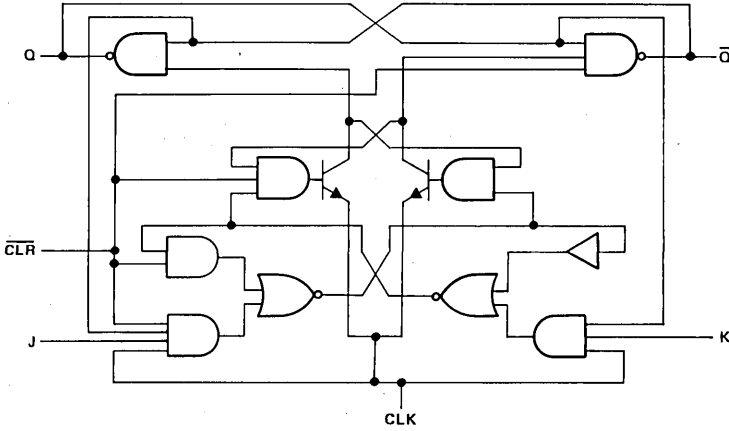

'LS107A

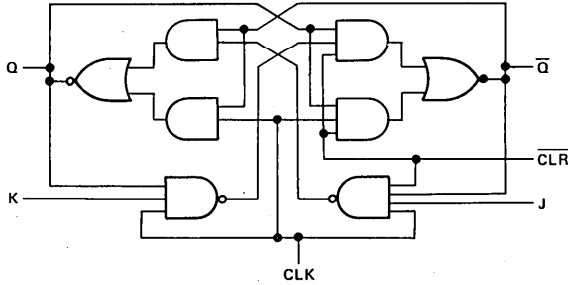

TYPES SN54107, SN54LS107A, SN74107, SN74LS107A DUAL J-K FLIP-FLOPS WITH CLEAR

logic symbols

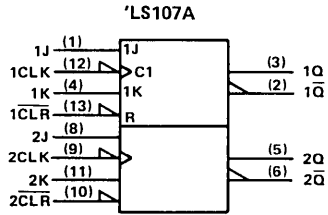
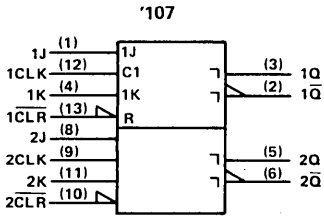

Pin numbers shown on logic notation are for D, J or N packages.

schematic of inputs and outputs

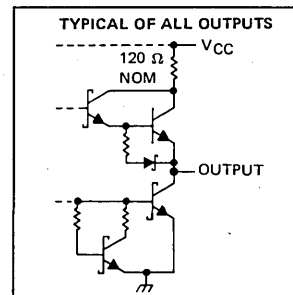
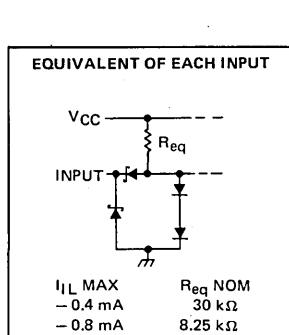
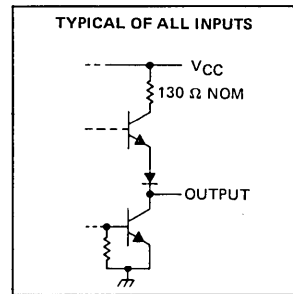
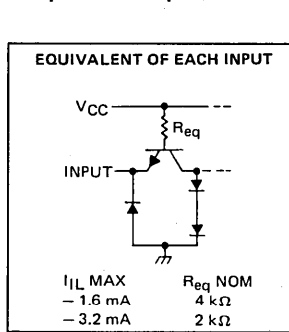

absolute maximum ratings over operating free-air temperature range (unless otherwise noted)

Supply voltage, V _{CC} (see Note 1)	7 V
Input voltage: '107	5.5 V
'LS107A	7 V
Operating free-air temperature range: SN54'	-55°C to 125°C
SN74'	0°C to 70°C
Storage temperature range	-65°C to 150°C

NOTE 1: Voltage values are with respect to network ground terminal.

TYPES SN54107, SN74107 DUAL J-K FLIP-FLOPS WITH CLEAR

recommended operating conditions

	SN54107			SN74107			UNIT
	MIN	NOM	MAX	MIN	NOM	MAX	
V _{CC} Supply voltage	4.5	5	5.5	4.75	5	5.25	V
V _{IH} High-level input voltage	2			2			V
V _{IL} Low-level input voltage	0.8			0.8			V
I _{OH} High-level output current	-0.4			-0.4			mA
I _{OL} Low-level output current	16			16			mA
t _w Pulse duration	CLK high	20		20		ns	
	CLK low	47		47			
	CLR low	25		25			
t _{SU} Input setup time before CLK↑	0			0			ns
t _H Input hold time-data after CLK↑	0			0			ns
T _A Operating free-air temperature	-55		125	0		70	°C

electrical characteristics over recommended operating free-air temperature range (unless otherwise noted)

PARAMETER	TEST CONDITIONS†	SN54107			SN74107			UNIT
		MIN	TYP‡	MAX	MIN	TYP‡	MAX	
V _{IK}	V _{CC} = MIN, I _I = -12 mA	-1.5			-1.5			V
V _{OH}	V _{CC} = MIN, V _{IH} = 2 V, V _{IL} = 0.8 V, I _{OH} = -0.4 mA	2.4	3.4		2.4	3.4		V
V _{OL}	V _{CC} = MIN, V _{IH} = 2 V, V _{IL} = 0.8 V, I _{OL} = 16 mA		0.2	0.4		0.2	0.4	V
I _I	V _{CC} = MAX, V _I = 5.5 V	1			1			mA
I _{IH}	J or K	40			40			μA
	All other	80			80			
I _{IL}	J or K	-1.6			-1.6			mA
	All other	-3.2			-3.2			
I _{OS} §	V _{CC} = MAX	-20	-57		-18	-57		mA
I _{CC}	V _{CC} = MAX, See Note 2	10	20		10	20		mA

† For conditions shown as MIN or MAX, use the appropriate value specified under recommended operating conditions.

‡ All typical values are at V_{CC} = 5 V, T_A = 25°C.

§ Not more than one output should be shorted at a time.

NOTE 2: With all outputs open, I_{CC} is measured with the Q and \bar{Q} outputs high in turn. At the time of measurement, the clock input is grounded.

switching characteristics, V_{CC} = 5 V, T_A = 25°C (see note 3)

PARAMETER	FROM (INPUT)	TO (OUTPUT)	TEST CONDITIONS	MIN	TYP	MAX	UNIT
f _{max}			R _L = 400 Ω, C _L = 15 pF	15	20		MHz
t _{PLH}	CLR	\bar{Q}		16	25		ns
t _{PHL}		Q		25	40		ns
t _{PLH}	CLK	Q or \bar{Q}		16	25		ns
t _{PHL}				25	40		ns

NOTE 3: See General Information Section for load circuits and voltage waveforms.

TYPES SN54LS107A, SN74LS107A DUAL J-K FLIP-FLOPS WITH CLEAR

recommended operating conditions

		SN54LS107A			SN74LS107A			UNIT
		MIN	NOM	MAX	MIN	NOM	MAX	
V _{CC}	Supply voltage	4.5	5	5.5	4.75	5	5.25	V
V _{IH}	High-level input voltage	2			2			V
V _{IL}	Low-level input voltage	0.7			0.8			V
I _{OH}	High-level output current	-0.4			-0.4			mA
I _{OL}	Low-level output current	4			8			mA
f _{clock}	Clock frequency	0 30			0 30			MHz
t _w	Pulse duration	CLK high	20		20		ns	
		CLR low	25		25			
t _{su}	Setup time before CLK ↓	data high or low	20		20		ns	
		CLR inactive	25		25			
t _h	Hold time-data after CLK ↓	0			20			ns
T _A	Operating free-air temperature	-55 125			0 70			°C

electrical characteristics over recommended operating free-air temperature range (unless otherwise noted)

PARAMETER		TEST CONDITIONS†		SN54LS107A		SN74LS107A		UNIT
				MIN	TYP‡	MAX	MIN	
V _{IK}		V _{CC} = MIN, I _I = -18 mA	-1.5		-1.5		V	
V _{OH}		V _{CC} = MIN, V _{IH} = 2 V, V _{IL} = MAX, I _{OH} = -0.4 mA	2.5	3.4	2.7	3.4	V	
V _{OL}		V _{CC} = MIN, V _{IL} = MAX, V _{IH} = 2 V, I _{OL} = 4 mA	0.25	0.4	0.25	0.4	V	
		V _{CC} = MIN, V _{IL} = MAX, V _{IH} = 2 V, I _{OL} = 8 mA			0.35	0.5		
I _I	J or K	V _{CC} = MAX, V _I = 7 V	0.1		0.1		mA	
	CLR		0.3		0.3			
	CLK		0.4		0.4			
I _{IH}	J or K	V _{CC} = MAX, V _I = 2.7 V	20		20		μA	
	CLR		60		60			
	CLK		80		80			
I _{IL}	J or K	V _{CC} = MAX, V _I = 0.4 V	-0.4		-0.4		mA	
	CLR or CLK		-0.8		-0.8			
I _{OS} §		V _{CC} = MAX, See Note 4	-20	-100	-20	-100	mA	
I _{CC}		V _{CC} = MAX, See Note 2	4	6	4	6	mA	

† For conditions shown as MIN or MAX, use the appropriate value specified under recommended operating conditions.

‡ All typical values are at V_{CC} = 5 V, T_A = 25°C.

§ Not more than one output should be shorted at a time, and the duration of the short circuit should not exceed one second.

NOTE 2: With all outputs open, I_{CC} is measured with the Q and \bar{Q} , outputs high in turn. At the time of measurement, the clock input is grounded.

NOTE 4: For certain devices where state commutation can be caused by shorting an output to ground, an equivalent test may be performed with V_O = 2.25 V and 2.125 V for the 54 family and the 74 family, respectively, with the minimum and maximum limits reduced to one half of their stated values.

switching characteristics, V_{CC} = 5 V, T_A = 25°C (see note 3)

PARAMETER	FROM (INPUT)	TO (OUTPUT)	TEST CONDITIONS		MIN	TYP	MAX	UNIT
f _{max}			R _L = 2 kΩ, C _L = 15 pF		30	45		MHz
t _{PLH}	$\overline{\text{CLR}}$ or CLK	Q or \bar{Q}			15	20		ns
t _{PHL}					15	20		ns

NOTE 3: See General Information Section for load circuits and voltage waveforms.

3

TTL DEVICES

TYPES SN54H108, SN74H108 DUAL J-K NEGATIVE-EDGE-TRIGGERED FLIP-FLOPS WITH PRESET, COMMON CLEAR, AND COMMON CLOCK

REVISED DECEMBER 1983

- Package Options Include Plastic and Ceramic DIPs
- Dependable Texas Instruments Quality and Reliability

SN54H108 ... J OR W PACKAGE
SN74H108 ... J OR N PACKAGE
(TOP VIEW)

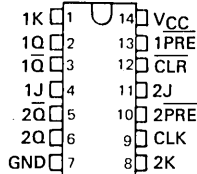

description

These dual monolithic J-K flip-flops are negative-edge-triggered. They feature individual J, K, and asynchronous preset inputs to each flip-flop as well as common clock and asynchronous clear inputs. When the clock goes high, the inputs are enabled and data will be accepted. Logical state of J and K inputs may be allowed to change when the clock pulse is in a high state and bistable will perform according to the truth table as long as minimum set-up times are observed. Input data is transferred to the outputs on the negative edge of the clock pulse.

The SN54H108 is characterized for operation over the full military temperature range of -55°C to 125°C . The SN74H108 is characterized for operation from 0°C to 70°C .

logic symbol

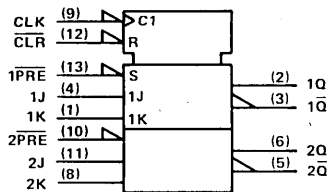

Pin numbers shown are for J and N packages.

FUNCTION TABLE

INPUTS					OUTPUTS	
PRE	CLR	CLK	J	K	Q	\bar{Q}
L	H	X	X	X	H	L
H	L	X	X	X	L	H
L	L	X	X	X	H†	H†
H	H	↓	L	L	Q_0	\bar{Q}_0
H	H	↓	H	L	H	L
H	H	↓	L	H	L	H
H	H	↓	H	H	TOGGLE	
H	H	H	X	X	Q_0	\bar{Q}_0

† This configuration is nonstable; that is, it will not persist when preset and clear inputs return to their inactive (high) level.

3

TTL DEVICES

PRODUCTION DATA

This document contains information current as of publication date. Products conform to specifications per the terms of Texas Instruments standard warranty. Production processing does not necessarily include testing of all parameters.

3-430

TEXAS
INSTRUMENTS

POST OFFICE BOX 225012 • DALLAS, TEXAS 75265

TYPES SN54H108, SN74H108 DUAL J-K NEGATIVE-EDGE-TRIGGERED FLIP-FLOPS WITH PRESET, COMMON CLEAR, AND COMMON CLOCK

logic diagram

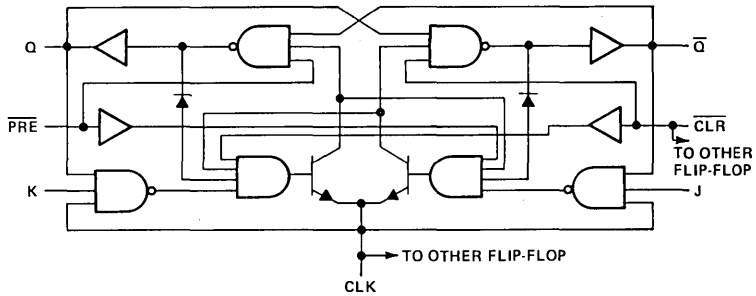

schematics of inputs and outputs

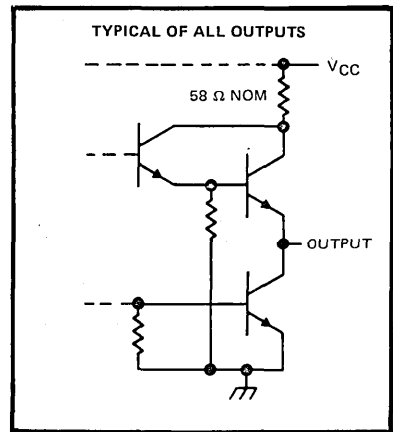
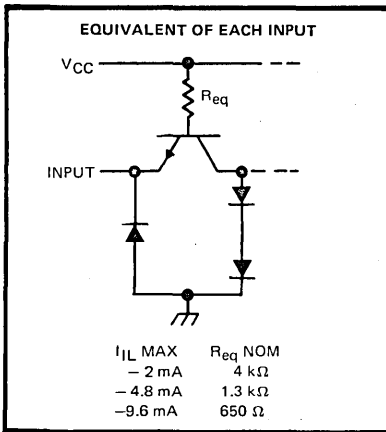

absolute maximum ratings over operating free-air temperature range (unless otherwise noted)

Supply voltage, V_{CC} (see Note 1)	7 V
Input voltage	5.5 V
Operating free-air temperature range: SN54H'	- 55°C to 125°C
SN74H'	0°C to 70°C
Storage temperature range	- 65°C to 150°C

NOTE 1: Voltage values are with respect to network ground terminal.

3
TTL DEVICES

TYPES SN54H108, SN74H108

DUAL J-K NEGATIVE-EDGE-TRIGGERED FLIP-FLOPS WITH PRESET, COMMON CLEAR, AND COMMON CLOCK

recommended operating conditions

		SN54H108			SN74H108			UNIT
		MIN	NOM	MAX	MIN	NOM	MAX	
V _{CC}	Supply voltage	4.5	5	5.5	4.75	5	5.25	V
V _{IH}	High-level input voltage	2			2			V
V _{IL}	Low-level input voltage			0.8			0.8	V
I _{OH}	High-level output current			-0.5			-0.5	mA
I _{OL}	Low-level output current			20			20	mA
t _w	Pulse duration	CLK high	10		10			ns
		CLK low	15		15			
		CLR or PRE low	16		16			
t _{su}	Setup time before CLK ↓	High-level data	10		10			ns
		Low-level data	13		13			
t _h	Hold time-data after CLK ↓	0			0			ns
T _A	Operating free-air temperature	-55		125	0		70	°C

electrical characteristics over recommended operating free-air temperature range (unless otherwise noted)

PARAMETER		TEST CONDITIONS†		SN54H108		SN74H108		UNIT	
				MIN	TYP‡	MAX	MIN		TYP‡
V _{IK}		V _{CC} = MIN, I _I = -8 mA		-1.5		-1.5		V	
V _{OH}		V _{CC} = MIN, V _{IH} = 2 V, V _{IL} = 0.8 V, I _{OH} = -0.5 mA	2.4	3.4	2.4	3.4		V	
V _{OL}		V _{CC} = MIN, V _{IH} = 2 V, V _{IL} = 0.8 V, I _{OL} = 20 mA	0.2	0.4	0.2	0.4		V	
I _I		V _{CC} = MAX, V _I = 5.5 V		1		1		mA	
I _{IH}	Any J or K	V _{CC} = MAX, V _I = 2.4 V		50		50		μA	
	CLR			200		200			
	PRE			100		100			
	CLK			0	-1	0	-1		
I _{IL}	Any J or K	V _{CC} = MAX, V _I = 0.4 V		-1	-2	-1	-2	mA	
	CLR			-2	-4	-2	-4		
	PRE			-1	-2	-1	-2		
	CLK			-6	-9.6	-6	-9.6		
I _{OS} §		V _{CC} = MAX	-40		-100	-40		-100	mA
I _{CC}		V _{CC} = MAX, See Note 2		20	38		20	38	mA

† For conditions shown as MIN or MAX, use the appropriate value specified under recommended operating conditions.

‡ All typical values are at V_{CC} = 5 V, T_A = 25°C.

§ Not more than one output should be shorted at a time, and duration of short-circuit should not exceed one second.

NOTE 2: With all outputs open, I_{CC} is measured with the Q and \bar{Q} outputs high in turn. At the time of measurement, the clock input is grounded.

switching characteristics, V_{CC} = 5 V, T_A = 25°C (see note 3)

PARAMETER	FROM (INPUT)	TO (OUTPUT)	TEST CONDITIONS		MIN	TYP	MAX	UNIT
f _{max}					40	50		MHz
t _{PLH}	PRE or CLR	Q or \bar{Q}	R _L = 280 Ω, C _L = 25 pF			8	12	ns
t _{PHL}	PRE or CLR (CLK high)	\bar{Q} or Q			15	20		ns
	PRE or CLR (CLK low)				23	35		
t _{PLH}	CLK	Q or \bar{Q}			10	15		ns
t _{PHL}				16	20			

NOTE 3: See General Information Section for load circuits and voltage waveforms.

TYPES SN54109, SN54LS109A, SN74109, SN74LS109A

DUAL J-K POSITIVE-EDGE-TRIGGERED FLIP-FLOPS WITH PRESET AND CLEAR

REVISED DECEMBER 1983

- Package Options Include Both Plastic and Ceramic Chip Carriers in Addition to Plastic and Ceramic DIPs.
- Dependable Texas Instruments Quality and Reliability

description

These devices contain two independent J-K positive-edge-triggered flip-flops. A low level at the preset or clear inputs sets or resets the outputs regardless of the levels of the other inputs. When preset and clear are inactive (high), data at the J and K inputs meeting the setup time requirements are transferred to the outputs on the positive-going edge of the clock pulse. Clock triggering occurs at a voltage level and is not directly related to the rise time of the clock pulse. Following the hold time interval, data at the J and K inputs may be changed without affecting the levels at the outputs. These versatile flip-flops can perform as toggle flip-flops by grounding K and tying J high. They also can perform as D-type flip-flops if J and K are tied together.

The SN54109 and SN54LS109A are characterized for operation over the full military temperature range of -55°C to 125°C. The SN74109 and SN74LS109A are characterized for operation from 0°C to 70°C.

FUNCTION TABLE (each flip-flop)

PRE	INPUTS			OUTPUTS		
	CLR	CLK	J	K	Q	\bar{Q}
L	H	X	X	X	H	L
H	L	X	X	X	L	H
L	L	X	X	X	H [†]	H [†]
H	H	↑	L	L	L	H
H	H	↑	H	L	TOGGLE	
H	H	↑	L	H	Q ₀	\bar{Q} ₀
H	H	↑	H	H	H	L
H	H	L	X	X	Q ₀	\bar{Q} ₀

[†] The output levels in this configuration are not guaranteed to meet the minimum levels for V_{OH} if the lows at preset and clear are near V_{IL} maximum. Furthermore, this configuration is nonstable; that is, it will not persist when preset or clear return to their inactive (high) level.

SN54109, SN54LS109A ... J OR W PACKAGE
SN74109 ... J OR N PACKAGE
SN74LS109A ... D, J OR N PACKAGE

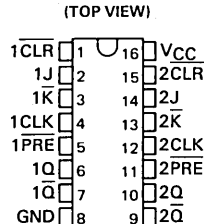

SN54LS109A ... FK PACKAGE
SN74LS109A ... FN PACKAGE

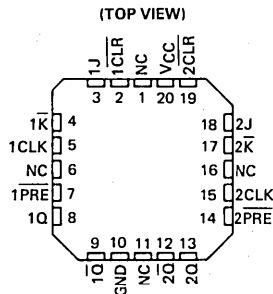

logic symbol

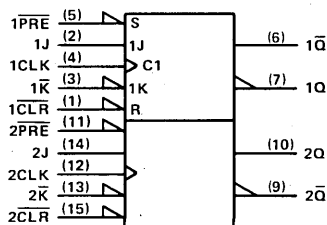

Pin numbers shown on logic notation are for D, J or N packages.

PRODUCTION DATA
This document contains information current as of publication date. Products conform to specifications per the terms of Texas Instruments standard warranty. Production processing does not necessarily include testing of all parameters.



**TEXAS
INSTRUMENTS**

POST OFFICE BOX 225012 • DALLAS, TEXAS 75265

TTL DEVICES

TYPES SN54109, SN74109
DUAL J-K POSITIVE-EDGE-TRIGGERED FLIP-FLOPS WITH PRESET AND CLEAR

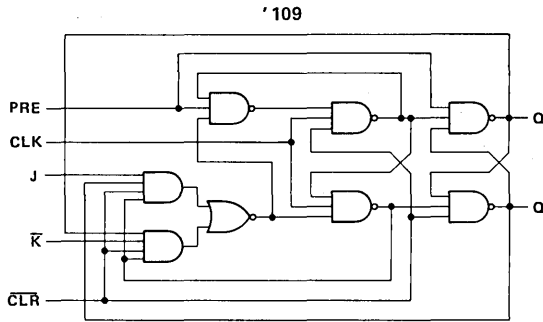
logic diagram



schematics of inputs and outputs

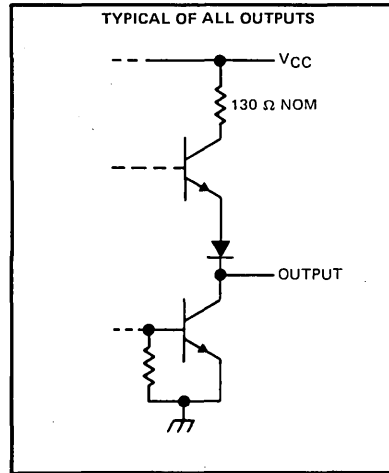
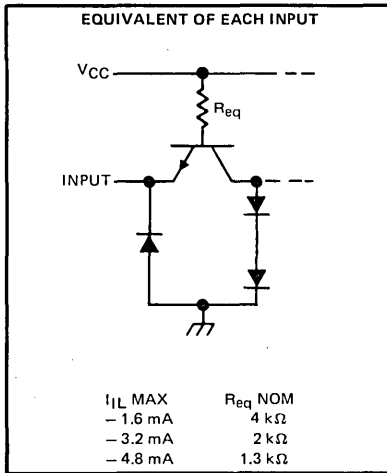

3

TTL DEVICES

TYPES SN54109, SN54LS109A,
SN74109, SN74LS109A

DUAL J-K POSITIVE-EDGE-TRIGGERED FLIP-FLOPS WITH PRESET AND CLEAR

schematic

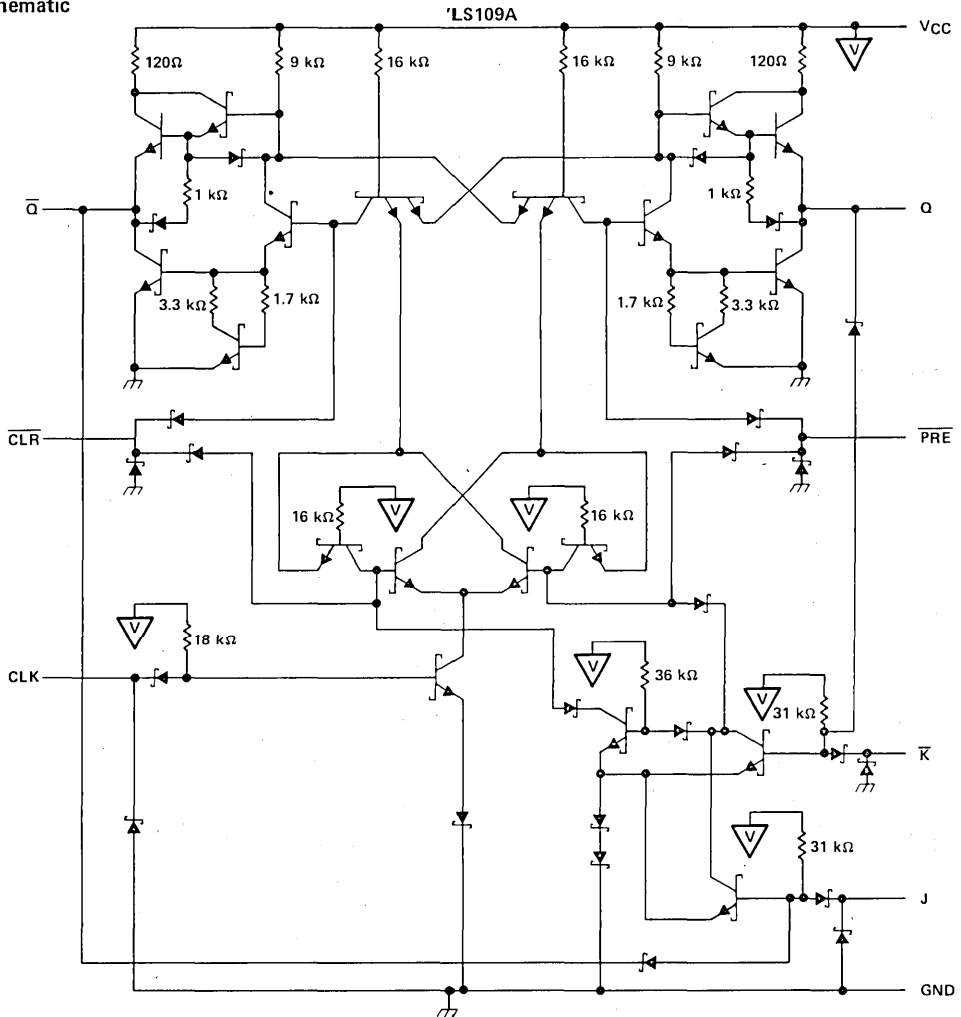

absolute maximum ratings over operating free-air temperature range (unless otherwise noted)

Supply voltage, V_{CC} (see Note 1)	7 V
Input voltage: '109	5.5 V
'LS109A	7 V
Operating free-air temperature range: SN54'	-55°C to 125°C
SN74'	0°C to 70°C
Storage temperature range	-65°C to 150°C

NOTE 1: Voltage values are with respect to network ground terminal.



TTL DEVICES

TYPES SN54109, SN74109

DUAL J-K POSITIVE-EDGE-TRIGGERED FLIP-FLOPS WITH PRESET AND CLEAR

recommended operating conditions

	SN54109			SN74109			UNIT		
	MIN	NOM	MAX	MIN	NOM	MAX			
V _{CC} Supply voltage	4.5	5	5.5	4.75	5	5.25	V		
V _{IH} High-level input voltage	2			2			V		
V _{IL} Low-level input voltage				0.8			V		
I _{OH} High-level output current				-0.8			mA		
I _{OL} Low-level output current				16			mA		
t _w Pulse duration	CLK high or low			20			ns		
	PRE or CLR low			20					
t _{SU} Input setup time before CLK †	10			10			ns		
t _H Input hold time-data after CLK †	6			6			ns		
T _A Operating free-air temperature	-55			125			0	70	°C

electrical characteristics over recommended operating free-air temperature range (unless otherwise noted)

PARAMETER	TEST CONDITIONS†	SN54109			SN74109			UNIT
		MIN	TYP‡	MAX	MIN	TYP‡	MAX	
V _{IK}	V _{CC} = MIN, I _I = -12 mA	-1.5			-1.5			V
V _{OH}	V _{CC} = MIN, V _{IH} = 2 V, V _{IL} = -0.8 V, I _{OH} = -0.8 mA	2.4	3.4		2.4	3.4		V
V _{OL}	V _{CC} = MIN, V _{IH} = 2 V, V _{IL} = 0.8 V, I _{OL} = 16 mA		0.2	0.4		0.2	0.4	V
I _I	V _{CC} = MAX, V _I = 5.5 V	1			1			mA
I _{IH}	J or K	40			40			μA
	CLR	160			160			
	PRE or CLK	80			80			
I _{IL}	J or K	-1.6			-1.6			mA
	CLR*	-4.8			-4.8			
	PRE*	-3.2			-3.2			
	CLK	-3.2			-3.2			
I _{OS} §	V _{CC} = MAX	-30		-85	-30		-85	mA
I _{CC}	V _{CC} = MAX, See Note 2		9	15		9	15	mA

† For conditions shown as MIN or MAX, use the appropriate value specified under recommended operating conditions.

‡ All typical values are at V_{CC} = 5 V, T_A = 25°C.

§ Not more than one output should be shorted at a time.

* Clear is tested with preset high and preset is tested with clear high.

NOTE 2: With all outputs open, I_{CC} is measured with the Q and Q̄ outputs high in turn. At the time of measurement, the clock input is grounded.

switching characteristics, V_{CC} = 5 V, T_A = 25°C (see note 3)

PARAMETER	FROM (INPUT)	TO (OUTPUT)	TEST CONDITIONS	MIN	TYP	MAX	UNIT
f _{max}			R _L = 400 Ω, C _L = 15 pF	25	33		MHz
t _{PLH}	PRE	Q			10	15	ns
t _{PHL}		Q̄			23	35	ns
t _{PLH}	CLR	Q̄			10	15	ns
t _{PHL}		Q			17	25	ns
t _{PLH}	CLK	Q or Q̄			10	16	ns
t _{PHL}						18	28

NOTE 3: See General Information Section for load circuits and voltage waveforms.

3

TTL DEVICES

TYPES SN54LS109A, SN74LS109A

DUAL J-K POSITIVE-EDGE-TRIGGERED FLIP-FLOPS WITH PRESET AND CLEAR

recommended operating conditions

		SN54LS109A			SN74LS109A			UNIT
		MIN	NOM	MAX	MIN	NOM	MAX	
V _{CC}	Supply voltage	4.5	5	5.5	4.75	5	5.25	V
V _{IH}	High-level input voltage	2			2			V
V _{IL}	Low-level input voltage			0.7			0.8	V
I _{OH}	High-level output current			-0.4			-0.4	mA
I _{OL}	Low-level output current			4			8	mA
f _{clock}	Clock frequency	0		25	0		25	MHz
t _w	Pulse duration	CLK high		25	25			ns
		PRE or CLR low		25	25			
t _{su}	Setup time before CLK †	High-level data		35	35			ns
		Low-level data		25	25			
t _h	Hold time-data after CLK †	5		5		ns		
T _A	Operating free-air temperature	-55		125		0 70		°C

electrical characteristics over recommended operating free-air temperature range (unless otherwise noted)

PARAMETER	TEST CONDITIONS†	SN54LS109A			SN74LS109A			UNIT
		MIN	TYP‡	MAX	MIN	TYP‡	MAX	
V _{IK}	V _{CC} = MIN, I _I = -18 mA			-1.5			-1.5	V
V _{OH}	V _{CC} = MIN, I _{OH} = -0.4 mA, V _{IH} = 2 V, V _{IL} = MAX,	2.5	3.4		2.7	3.4		V
V _{OL}	V _{CC} = MIN, I _{OL} = 4 mA, V _{IL} = MAX, V _{IH} = 2 V,		0.25	0.4		0.25	0.4	V
	V _{CC} = MIN, I _{OL} = 8 mA, V _{IL} = MAX, V _{IH} = 2 V,					0.35	0.5	
I _I	J, K or CLK	V _{CC} = MAX, V _I = 7 V		0.1	0.1		mA	
	CLR or PRE	V _{CC} = MAX, V _I = 7 V		0.2	0.2			
I _{IH}	J, R or CLK	V _{CC} = MAX, V _I = 2.7 V		20	20		μA	
	CLR or PRE	V _{CC} = MAX, V _I = 2.7 V		40	40			
I _{IL}	J, R or CLK	V _{CC} = MAX, V _I = 0.4 V		-0.4	-0.4		mA	
	CLR or PRE	V _{CC} = MAX, V _I = 0.4 V		-0.8	-0.8			
I _{OS} §	V _{CC} = MAX, See Note 4	-20	-100		-20	-100	mA	
I _{CC}	V _{CC} = MAX, See Note 2		4	8		4	8	mA

† For conditions shown as MIN or MAX, use the appropriate value specified under recommended operating conditions.

‡ All typical values are at V_{CC} = 5 V, T_A = 25°C.

§ Not more than one output should be shorted at a time, and the duration of the short circuit should not exceed one second.

NOTE 2: With all outputs open, I_{CC} is measured with the Q and \bar{Q} outputs high in turn. At the time of measurement, the clock input is grounded.

NOTE 4: For certain devices where state commutation can be caused by shorting an output to ground, an equivalent test may be performed with V_O = 2.25 V and 2.125 V for the 54 family and the 74 family, respectively with the minimum and maximum limits reduced to one half of their stated values.

switching characteristics, V_{CC} = 5 V, T_A = 25°C (see note 3)

PARAMETER	FROM (INPUT)	TO (OUTPUT)	TEST CONDITIONS		MIN	TYP	MAX	UNIT
f _{max}					25	33		MHz
t _{PLH}	CLR, PRE	Q or \bar{Q}	R _L = 2 kΩ,	C _L = 15 pF		13	25	ns
t _{PHL}	or CLK					25	40	ns

NOTE 3: See General Information Section for load circuits and voltage waveforms.

TYPES SN54110, SN74110 AND-GATED J-K MASTER-SLAVE FLIP-FLOPS WITH DATA LOCKOUT

REVISED DECEMBER 1983

- Package Options Include Plastic and Ceramic DIPs
- Dependable Texas Instruments Quality and Reliability

SN54110 ... J OR W PACKAGE
SN74110 ... J OR N PACKAGE
(TOP VIEW)

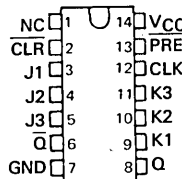

NC - No internal connection

description

The SN54110 and SN74110 are d-c coupled, variable-skew, J-K flip-flops which utilize TTL circuitry to obtain 25-MHz performance typically. They are termed "variable-skew" because they allow the maximum clock skew in a system to be a direct function of the clock pulse width. The J and K inputs are enabled only during a short period (20 nanoseconds maximum setup time plus 5 nanoseconds maximum hold time) on the rising edge of the clock pulse. After this, inputs may be changed while the clock is at high level without affecting the state of the master. On the threshold level of the falling edge of the clock pulse, the data stored in the master during the rising edge will be transferred to the output. The effective allowable clock skew then is minimum propagation delay time minus hold time, plus clock pulse width. This means that the system designer can set the maximum allowable clock skew needed by varying the clock pulse width. Thus system design is made easier and the requirements for sophisticated clock distribution systems are minimized or, in some cases, entirely eliminated. These flip-flops have an additional feature—the synchronous input has reduced sensitivity to data change while the clock is high because the data need be present for only a short period of time and the system's susceptibility to noise is thereby effectively reduced.

The SN54110/SN74110 has the same functional advantage as the SN5472/SN7472 in that three-input AND logic is provided for both the J and K data functions. Preset and clear inputs, which are completely independent of the state of the clock, are also provided. The SN54110 is characterized for operation over the full military temperature range of -55°C to 125°C; the SN74110 is characterized for operation from 0°C to 70°C.

logic symbol

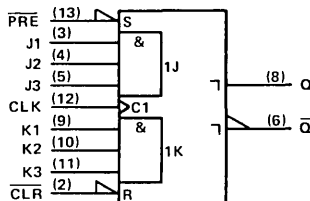

Pin numbers shown are for J and N packages.

positive logic

$$J = J1 \cdot J2 \cdot J3$$

$$K = K1 \cdot K2 \cdot K3$$

FUNCTION TABLE

INPUTS					OUTPUTS	
PRE	CLR	CLK	J	K	Q	Q̄
L	H	X	X	X	H	L
H	L	X	X	X	L	H
L	L	X	X	X	H†	H†
H	H	⌋	L	L	Q ₀	Q̄ ₀
H	H	⌋	H	L	H	L
H	H	⌋	L	H	L	H
H	H	⌋	H	H	TOGGLE	

† This configuration is non-stable; that is, it will not persist when preset or clear return to their inactive (high) level.

PRODUCTION DATA

This document contains information current as of publication date. Products conform to specifications per the terms of Texas Instruments standard warranty. Production processing does not necessarily include testing of all parameters.

TYPES SN54110, SN74110 AND-GATED J-K MASTER-SLAVE FLIP-FLOPS WITH DATA LOCKOUT

recommended operating conditions

	SN54110			SN74110			UNIT
	MIN	NOM	MAX	MIN	NOM	MAX	
V _{CC} Supply voltage	4.5	5	5.5	4.75	5	5.25	V
V _{IH} High-level input voltage	2			2			V
V _{IL} Low-level input voltage			0.8			0.8	V
I _{OH} High-level output current			-0.8			-0.8	mA
I _{OL} Low-level output current			16			16	mA
t _w Pulse duration	CLK high or low		25	25			ns
	PRE or CLR low		25	25			
t _{SU} Input setup time before CLK †	20			20			ns
t _H Input hold time-data after CLK †	5			5			ns
T _A Operating free-air temperature	-55		125	0		70	°C

electrical characteristics over recommended operating free-air temperature range (unless otherwise noted)

PARAMETER	TEST CONDITIONS†	SN54110			SN74110			UNIT
		MIN	TYP	MAX	MIN	TYP	MAX	
V _{IK}	V _{CC} = MIN, I _I = -12 mA			-1.5			-1.5	V
V _{OH}	V _{CC} = MIN, V _{IH} = 2 V, V _{IL} = 0.8 V, I _{OH} = -0.8 mA	2.4	3.4		2.4	3.4		V
V _{OL}	V _{CC} = MIN, V _{IH} = 2 V, V _{IL} = 0.8 V, I _{OL} = 16 mA		0.2	0.4		0.2	0.4	V
I _I	V _{CC} = MAX, V _I = 5.5 V			1			1	mA
I _{IH}	J, K or CLK			40			40	μA
	CLR or PRE	V _{CC} = MAX, V _I = 2.4 V		160			160	
	PRE			160			160	
I _{IL}	J, K or CLK			-1.6			-1.6	mA
	CLR*	V _{CC} = MAX, V _I = 0.4 V		-3.2			-3.2	
	PRE*			-3.2			-3.2	
I _{OS} §	V _{CC} = MAX	-20		-57	-18		-57	mA
I _{CC}	V _{CC} = MAX, See Note 2		20	34		20	34	mA

† For conditions shown as MIN or MAX, use the appropriate value specified under recommended operating conditions.

‡ All typical values are at V_{CC} = 5 V, T_A = 25°C.

§ Not more than one output should be shorted at a time.

* Clear is tested with preset high and preset is tested with clear high.

NOTE 2: With all outputs open, I_{CC} is measured with the Q and \bar{Q} outputs high in turn. At the time of measurement, the clock input is at 4.5 V.

switching characteristics, V_{CC} = 5 V, T_A = 25°C (see note 3)

PARAMETER	FROM (INPUT)	TO (OUTPUT)	TEST CONDITIONS		MIN	TYP	MAX	UNIT
f _{max}					20	25		MHz
t _{PLH}	$\overline{\text{PRE}}$ or $\overline{\text{CLR}}$	Q or \bar{Q}	R _L = 400 Ω,	C _L = 15 pF		12	20	ns
t _{PHL}						18	25	ns
t _{PLH}	CLK	Q or \bar{Q}				20	30	ns
t _{PHL}						13	20	ns

NOTE 3: See General Information Section for load circuits and voltage waveforms.

TYPES SN54111, SN74111 DUAL J-K MASTER-SLAVE FLIP-FLOPS WITH DATA LOCKOUT

REVISED DECEMBER 1983

- Package Options Include Plastic and Ceramic DIPs
- Dependable Texas Instruments Quality and Reliability

description

The SN54111 and SN74111 are d-c coupled, variable-skew, J-K flip-flops which utilize TTL circuitry to obtain 25-MHz performance typically. They are termed "variable-skew" because they allow the maximum clock skew in a system to be a direct function of the clock pulse width. The J and K inputs are enabled to accept data only during a short period (30 nanoseconds maximum hold time) starting with, and immediately following the rising edge of the clock pulse. After this, inputs may be changed while the clock is at the high level without affecting the state of the master. At the threshold level of the falling edge of the clock pulse, the data stored in the master will be transferred to the output. The effective allowable clock skew then is minimum propagation delay time minus hold time, plus clock pulse width. This means that the system designer can set the maximum allowable clock skew needed by varying the clock pulse width. Thus system design is made easier and the requirements for sophisticated clock distribution systems are minimized or, in some cases, entirely eliminated. These flip-flops have an additional feature—the synchronous input has reduced sensitivity to data change while the clock is high because the data need be present for only a short period of time and the system's susceptibility to noise is thereby effectively reduced.

The SN54111 is characterized for operation over the full military temperature range of -55°C to 125°C ; the SN74111 is characterized for operation from 0°C to 70°C .

FUNCTION TABLE

INPUTS					OUTPUTS	
PRE	CLR	CLK	J	K	Q	\bar{Q}
L	H	X	X	X	H	L
H	L	X	X	X	L	H
L	L	X	X	X	H [†]	H [†]
H	H	\neg	L	L	Q_0	\bar{Q}_0
H	H	\neg	H	L	H	L
H	H	\neg	L	H	L	H
H	H	\neg	H	H	TOGGLE	

[†] This configuration is non-stable; that is, it will not persist when preset or clear return to their inactive (high) level.

SN54111 ... J OR W PACKAGE
SN74111 ... J OR N PACKAGE
(TOP VIEW)

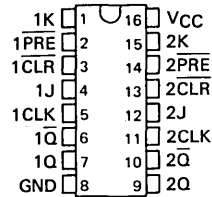

logic symbol

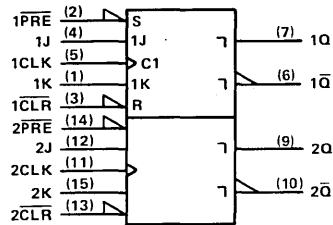

Pin numbers shown are for J and N packages.

3
TTL DEVICES

PRODUCTION DATA
This document contains information current as of publication date. Products conform to specifications per the terms of Texas Instruments standard warranty. Production processing does not necessarily include testing of all parameters.

**TEXAS
INSTRUMENTS**

POST OFFICE BOX 225012 • DALLAS, TEXAS 75265

**TYPES SN54111, SN74111
DUAL J-K MASTER-SLAVE
FLIP-FLOPS WITH DATA LOCKOUT**

logic diagram

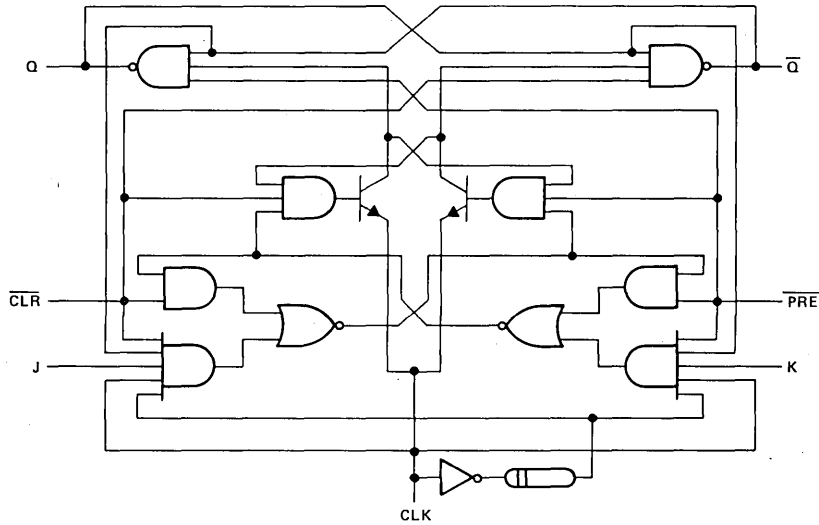

schematics of inputs and outputs

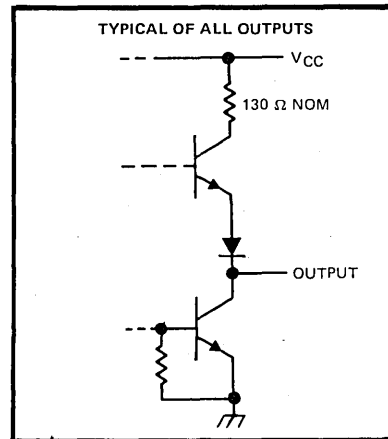
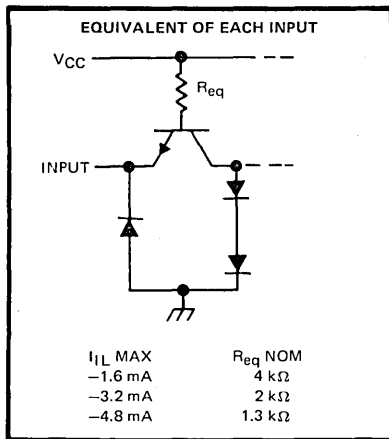

absolute maximum ratings over operating free-air temperature range (unless otherwise noted)

Supply voltage, V_{CC} (see Note 1)	7 V
Input voltage	5.5 V
Operating free-air temperature range: SN54'	-55°C to 125°C
SN74'	0°C to 70°C
Storage temperature range	-65°C to 150°C

NOTE 1: Voltage values are with respect to network ground terminal.

TYPES SN54111, SN74111
DUAL J-K MASTER-SLAVE FLIP-FLOPS WITH DATA LOCKOUT

recommended operating conditions

		SN54111			SN74111			UNIT
		MIN	NOM	MAX	MIN	NOM	MAX	
V _{CC}	Supply voltage	4.5	5	5.5	4.75	5	5.25	V
V _{IH}	High-level input voltage	2			2			V
V _{IL}	Low-level input voltage	0.8			0.8			V
I _{OH}	High-level output current	-0.8			-0.8			mA
I _{OL}	Low-level output current	16			16			mA
t _w	Pulse duration	CLK high or low		25	25		ns	
		PRE or CLR low		25	25			
t _{su}	Input setup time before CLK †	0			0			ns
t _h	Input hold time data after CLK †	30			30			ns
T _A	Operating free-air temperature	-55	125		0	70		°C

electrical characteristics over recommended operating free-air temperature range (unless otherwise noted)

PARAMETER	TEST CONDITIONS †	SN54111			SN74111			UNIT
		MIN	TYP ‡	MAX	MIN	TYP ‡	MAX	
V _{IK}	V _{CC} = MIN, I _I = -12 mA	-1.5			-1.5			V
V _{OH}	V _{CC} = MIN, V _{IH} = 2 V, V _{IL} = 0.8 V, I _{OH} = -0.8 mA	2.4	3.4		2.4	3.4		V
V _{OL}	V _{CC} = MIN, V _{IH} = 2 V, V _{IL} = 0.8 V, I _{OL} = 16 mA	0.2	0.4		0.2	0.4		V
I _I	V _{CC} = MAX, V _I = 5.5 V	1			1			mA
I _{IH}	J or K	40			40			μA
	CLR or PRE	80			80			
	CLK	120			120			
	J or K	-1.6			-1.6			
I _{IL}	CLR*	-3.2			-3.2			mA
	PRE*	-3.2			-3.2			
	CLK	-4.8			-4.8			
		-4.8			-4.8			
I _{OS} §	V _{CC} = MAX	-20	-57		-18	-57		mA
I _{CC}	V _{CC} = MAX, See Note 2	14	20.5		14	20.5		mA

† For conditions shown as MIN or MAX, use the appropriate value specified under recommended operating conditions.

‡ All typical values are at V_{CC} = 5 V, T_A = 25°C.

§ Not more than one output should be shorted at a time.

* Clear is tested with preset high and preset is tested with clear high.

NOTE 2: With all outputs open, I_{CC} is measured with the Q and Q outputs high in turn. At the time of measurement, the clock input is at 4.5 V.

switching characteristics, V_{CC} = 5 V, T_A = 25°C (see note 3)

PARAMETER	FROM (INPUT)	TO (OUTPUT)	TEST CONDITIONS		MIN	TYP	MAX	UNIT
f _{max}					20	25		MHz
t _{PLH}	PRE or CLR	Q or Q̄	R _L = 400 Ω,	C _L = 15 pF	12	18		ns
t _{PHL}					21	30		ns
t _{PLH}	CLK	Q or Q̄			12	17		ns
t _{PHL}					20	30		ns

NOTE 3: See General Information Section for load circuits and voltage waveforms.

TYPES SN54LS112A, SN54S112, SN74LS112A, SN74S112 DUAL J-K NEGATIVE-EDGE-TRIGGERED FLIP-FLOPS WITH PRESET AND CLEAR

REVISED DECEMBER 1983

- Fully Buffered to Offer Maximum Isolation from External Disturbance
- Package Options Include Both Plastic and Ceramic Carriers in Addition to Plastic and Ceramic DIPs.
- Dependable Texas Instruments Quality and Reliability

description

These devices contain two independent J-K negative-edge-triggered flip-flops. A low level at the preset or clear inputs sets or resets the outputs regardless of the levels of the other inputs. When preset and clear are inactive (high), data at the J and K inputs meeting the setup time requirements are transferred to the outputs on the negative-going edge of the clock pulse. Clock triggering occurs at a voltage level and is not directly related to the rise time of the clock pulse. Following the hold time interval, data at the J and K inputs may be changed without affecting the levels at the outputs. These versatile flip-flops can perform as toggle flip-flops by tying J and K high.

The SN54LS112A and SN54S112 are characterized for operation over the full military temperature range of -55°C to 125°C . The SN74LS112A and SN74S112 are characterized for operation from 0°C to 70°C .

FUNCTION TABLE (each flip-flop)

INPUTS					OUTPUTS	
PRE	CLR	CLK	J	K	Q	\bar{Q}
L	H	X	X	X	H	L
H	L	X	X	X	L	H
L	L	X	X	X	H^{\dagger}	H^{\dagger}
H	H	\downarrow	L	L	Q_0	\bar{Q}_0
H	H	\downarrow	H	L	H	L
H	H	\downarrow	L	H	L	H
H	H	\downarrow	H	H	TOGGLE	
H	H	H	X	X	Q_0	\bar{Q}_0

[†] The output levels in this configuration are not guaranteed to meet the minimum levels for V_{OH} if the lows at preset and clear are near V_{IL} maximum. Furthermore, this configuration is nonstable, that is, it will not persist when either preset or clear returns to its inactive (high) level.

SN54LS112A, SN54S112 ... J OR W PACKAGE
SN74LS112A, SN74S112 ... D, J OR N PACKAGE
(TOP VIEW)

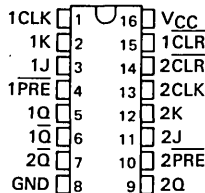

SN54LS112A, SN54S112 ... FK PACKAGE
SN74LS112A, SN74S112 ... FN PACKAGE
(TOP VIEW)

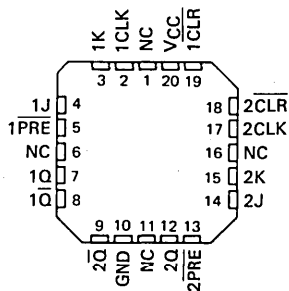

NC - No internal connection

logic symbol

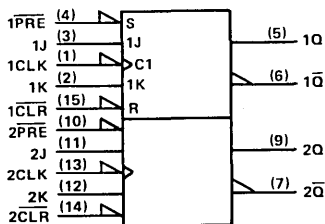

Pin numbers shown on logic notation are for D, J or N packages.

PRODUCTION DATA

This document contains information current as of publication date. Products conform to specifications per the terms of Texas Instruments standard warranty. Production processing does not necessarily include testing of all parameters.

TYPES SN54LS112A, SN54S112, SN74LS112A, SN74S112
 DUAL J-K NEGATIVE-EDGE-TRIGGERED
 FLIP-FLOPS WITH PRESET AND CLEAR

logic diagrams

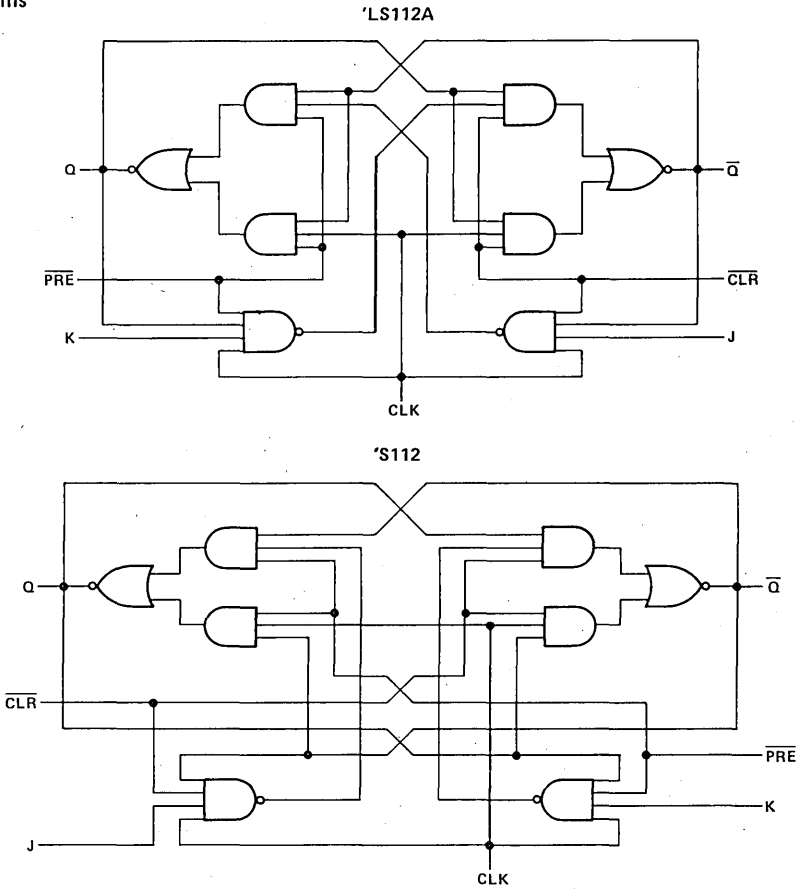

TTL DEVICES

TYPES SN54LS112A, SN54S112, SN74LS112A, SN74S112
DUAL J-K NEGATIVE-EDGE-TRIGGERED
FLIP-FLOPS WITH PRESET AND CLEAR

schematics of inputs and outputs

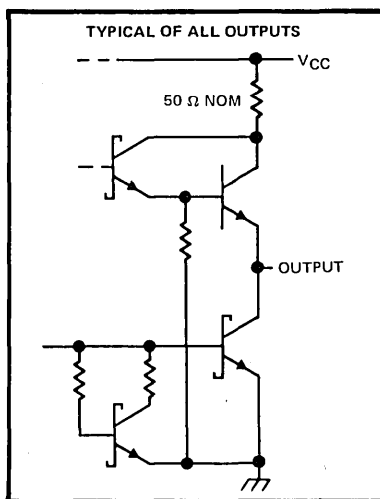
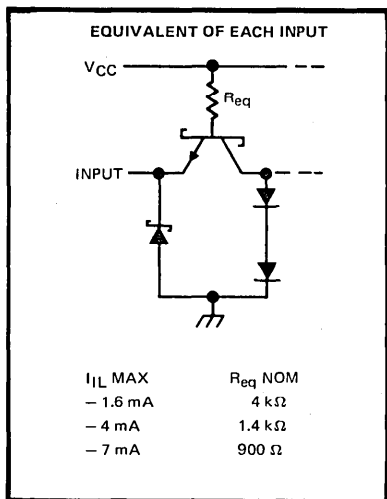
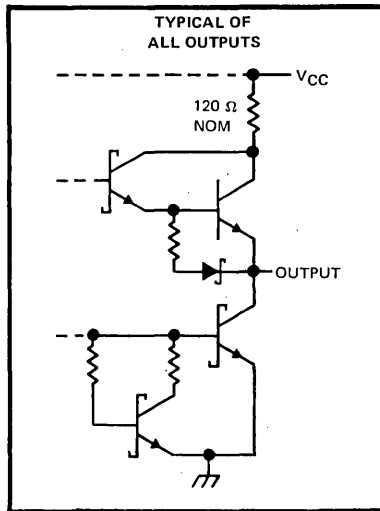
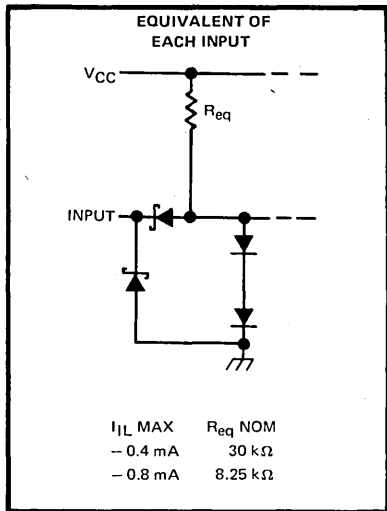

absolute maximum ratings over operating free-air temperature range (unless otherwise noted)

Supply voltage, V_{CC} (see Note 1)	7 V
Input voltage: 'LS112A	7 V
'S112	5.5 V
Operating free-air temperature range: SN54'	- 55°C to 125°C
SN74'	0°C to 70°C
Storage temperature range	- 65°C to 150°C

NOTE 1: Voltage values are with respect to network ground terminal.

TYPES SN54S112, SN74S112 DUAL J-K NEGATIVE-EDGE-TRIGGERED FLIP-FLOPS WITH PRESET AND CLEAR

recommended operating conditions

		SN54LS112A			SN74LS112A			UNIT
		MIN	NOM	MAX	MIN	NOM	MAX	
V _{CC}	Supply voltage	4.5	5	5.5	4.75	5	5.25	V
V _{IH}	High-level input voltage	2			2			V
V _{IL}	Low-level input voltage	0.7			0.8			V
I _{OH}	High-level output current	-0.4			-0.4			mA
I _{OL}	Low-level output current	4			8			mA
f _{clock}	Clock frequency	0 30			0 30			MHz
t _w	Pulse duration	CLK high	20		20			ns
		PRE or CLR low	25		25			
t _{su}	Setup time after CLK ↓	data high or low	20		20			ns
		CLR inactive	25		25			
		PRE inactive	20		20			
t _h	Hold time-data after CLK ↓	0			0			ns
T _A	Operating free-air temperature	-55 125			0 70			°C

electrical characteristics over recommended operating free-air temperature range (unless otherwise noted)

PARAMETER		TEST CONDITIONS†		SN54LS112A		SN74LS112A		UNIT
				MIN	TYP‡	MAX	MIN	
V _{IK}		V _{CC} = MIN, I _I = -18 mA	-1.5		-1.5		V	
V _{OH}		V _{CC} = MIN, I _{OH} = -0.4 mA, V _{IH} = 2 V, V _{IL} = MAX	2.5	3.4	2.7	3.4	V	
V _{OL}		V _{CC} = MIN, V _{IL} = MAX, V _{IH} = 2 V, I _{OL} = 4 mA	0.25	0.4	0.25	0.4	V	
		V _{CC} = MIN, V _{IL} = MAX, V _{IH} = 2 V, I _{OL} = 8 mA	0.35 0.5					
I _I	J or K	V _{CC} = MAX, V _I = 7 V	0.1		0.1		mA	
	CLR or PRE		0.3		0.3			
	CLK		0.4		0.4			
I _{IH}	J or K	V _{CC} = MAX, V _I = 2.7 V	20		20		μA	
	CLR or PRE		60		60			
	CLK		80		80			
I _{IL}	J or K	V _{CC} = MAX, V _I = 0.4 V	-0.4		-0.4		mA	
	All other		-0.8		-0.8			
I _{OS} §		V _{CC} = MAX, See Note 4	-20	-100	-20	-100	mA	
I _{CC}		V _{CC} = MAX, See Note 2	4	6	4	6	mA	

† For conditions shown as MIN or MAX, use the appropriate value specified under recommended operating conditions.

‡ All typical values are at V_{CC} = 5 V, T_A = 25°C.

§ Not more than one output should be shorted at a time, and the duration of the short circuit should not exceed one second.

NOTE 2: With all outputs open, I_{CC} is measured with the Q and Q̄ outputs high in turn. At the time of measurement, the clock input is grounded.

NOTE 4: For certain devices where state commutation can be caused by shorting an output to ground, an equivalent test may be performed with V_O = 2.25 V and 2.125 V for the '54 family and the '74 family, respectively, with the minimum and maximum limits reduced to one half of their stated values.

switching characteristics, V_{CC} = 5 V, T_A = 25°C (see note 3)

PARAMETER	FROM (INPUT)	TO (OUTPUT)	TEST CONDITIONS		MIN	TYP	MAX	UNIT
f _{max}					30	45		MHz
t _{PLH}	CLR, PRE or CLK	Q or Q̄	R _L = 2 kΩ,	C _L = 15 pF	15 20			ns
t _{PHL}					15 20			ns

NOTE 3: See General Information Section for load circuits and voltage waveforms.

TYPES SN54LS112A, SN74LS112A

DUAL J-K NEGATIVE-EDGE-TRIGGERED FLIP-FLOPS WITH PRESET AND CLEAR

recommended operating conditions

		SN54S112			SN74S112			UNIT
		MIN	NOM	MAX	MIN	NOM	MAX	
V _{CC}	Supply voltage	4.5	5	5.5	4.75	5	5.25	V
V _{IH}	High-level input voltage	2			2			V
V _{IL}	Low-level input voltage				0.8			V
I _{OH}	High-level output current				-1			mA
I _{OL}	Low-level output current				20			mA
t _w	Pulse duration	CLK high		6	6		ns	
		CLK low		6.5	6.5			
		PRE or CLR low		8	8			
t _{su}	Setup time before CLK ↓	data high or low		3	3		ns	
t _h	Hold time-data after CLK ↓			0	0		ns	
T _A	Operating free-air temperature	-55	125		0	70		°C

electrical characteristics over recommended free-air temperature range (unless otherwise noted)

PARAMETER		TEST CONDITIONS†		SN54S112			SN74S112			UNIT
				MIN	TYP‡	MAX	MIN	TYP‡	MAX	
V _{IK}		V _{CC} = MIN,	I _I = -18 mA	-1.2			-1.2			V
V _{OH}		V _{CC} = MIN,	V _{IH} = 2 V, V _{IL} = 0.8 V, I _{OH} = -1 mA	2.5	3.4		2.7	3.4		V
V _{OL}		V _{CC} = MIN,	V _{IH} = 2 V, V _{IL} = 0.8 V, I _{OL} = 20 mA	0.5			0.5			V
I _I		V _{CC} = MAX,	V _I = 5.5 V	1			1			mA
I _{IH}	J or K	V _{CC} = MAX,	V _I = 2.7 V	50			50			μA
	All other			100			100			
I _{IL}	J or K	V _{CC} = MAX,	V _I = 0.5 V	-1.6			-1.6			mA
	CLR*			-7			-7			
	PRE*			-7			-7			
	CLK			-4			-4			
I _{OS} §		V _{CC} = MAX		-40	-100		-40	-100		mA
I _{CC}		V _{CC} = MAX,	See Note 2	15	25		15	25		mA

† For conditions shown as MIN or MAX, use the appropriate value specified under recommended operating conditions.

‡ All typical values are at V_{CC} = 5 V, T_A = 25°C.

§ Not more than one output should be shorted at a time, and the duration of the short circuit should not exceed one second.

* Clear is tested with preset high and preset is tested with clear high.

NOTE 2: With all outputs open, I_{CC} is measured with the Q and \bar{Q} outputs high in turn. At the time of measurement, the clock input is grounded.

switching characteristics, V_{CC} = 5 V, T_A = 25°C (see note 3)

PARAMETER	FROM (INPUT)	TO (OUTPUT)	TEST CONDITIONS		MIN	TYP	MAX	UNIT
f _{max}					80	125		MHz
t _{PLH}	PRE or CLR	Q or \bar{Q}	R _L = 280 Ω, C _L = 15 pF		4		7	ns
t _{PHL}	PRE or CLR (CLK high)	\bar{Q} or Q			5		7	ns
	PRE or CLR (CLK low)				5		7	ns
t _{PLH}	CLK	Q or \bar{Q}			4		7	
t _{PHL}			5		7			

NOTE 3: See General Information Section for load circuits and voltage waveforms.

TYPES SN54LS113A, SN54S113, SN74LS113A, SN74S113 DUAL J-K NEGATIVE-EDGE-TRIGGERED FLIP-FLOPS WITH PRESET

REVISED DECEMBER 1983

- Fully Buffered to Offer Maximum Isolation from External Disturbance
- Package Options Include Both Plastic and Ceramic Carriers in Addition to Plastic and Ceramic DIPs.
- Dependable Texas Instruments Quality and Reliability

description

These devices contain two independent J-K negative-edge-triggered flip-flops. A low level at the preset input sets the outputs regardless of the levels of the other inputs. When preset (PRE) is inactive (high), data at the J and K inputs meeting the setup time requirements are transferred to the outputs on the negative-going edge of the clock pulse. Clock triggering occurs at a voltage level and is not directly related to the rise time of the clock pulse. Following the hold time interval, data at the J and K inputs may be changed without affecting the levels at the outputs. These versatile flip-flops can perform as toggle flip-flops by tying J and K high.

The SN54LS113A and SN54S113 are characterized for operation over the full military temperature range of -55°C to 125°C . The SN74LS113A and SN74S112 are characterized for operation from 0°C to 70°C .

SN54LS113A, SN54S113 ... J OR W PACKAGE
SN74LS113A, SN74S113 ... D, J OR N PACKAGE

(TOP VIEW)

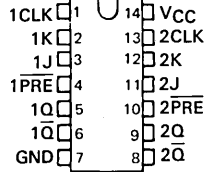

SN54LS113A, SN54S113 ... FK PACKAGE
SN74LS113A, SN74S113 ... FN PACKAGE

(TOP VIEW)

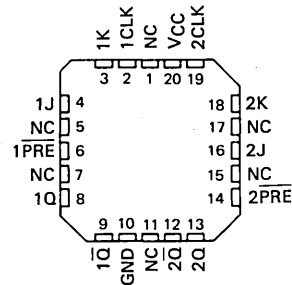

NC - No internal connection

FUNCTION TABLE (each flip-flop)

INPUTS				OUTPUTS	
PRE	CLK	J	K	Q	Q-bar
L	X	X	X	H	L
H	↓	L	L	Q ₀	Q ₀ -bar
H	↓	H	L	H	L
H	↓	L	H	L	H
H	↓	H	H	TOGGLE	
H	H	X	X	Q ₀	Q ₀ -bar

logic symbol

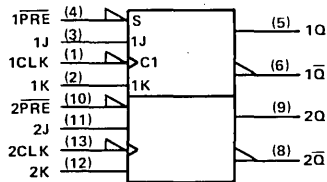

Pin numbers shown on logic notation are for D, J or N packages.

PRODUCTION DATA
This document contains information current as of publication date. Products conform to specifications per the terms of Texas Instruments standard warranty. Production processing does not necessarily include testing of all parameters.

TEXAS
INSTRUMENTS

POST OFFICE BOX 225012 • DALLAS, TEXAS 75265

3
TTL DEVICES

TYPES SN54LS113A, SN54S113, SN74LS113A, SN74S113
 DUAL J-K NEGATIVE-EDGE-TRIGGERED
 FLIP-FLOPS WITH PRESET

logic diagrams

'LS113A

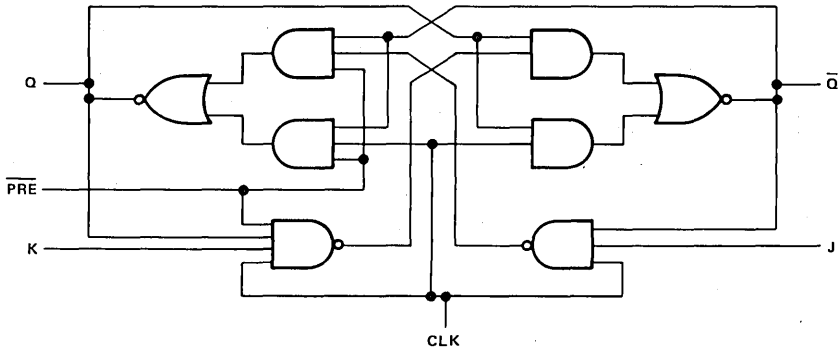

'S113

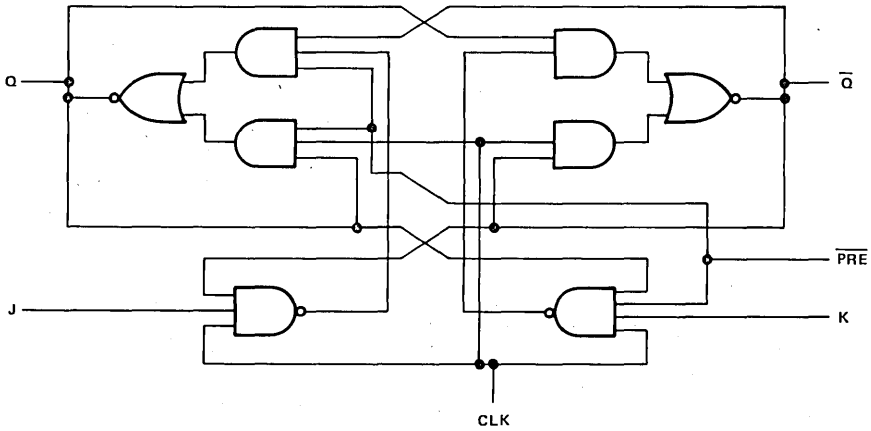

3 TTL DEVICES

TYPES SN54LS113A, SN54S113, SN74LS113A, SN74S113
 DUAL J-K NEGATIVE-EDGE-TRIGGERED
 FLIP-FLOPS WITH PRESET

schematics of inputs and outputs

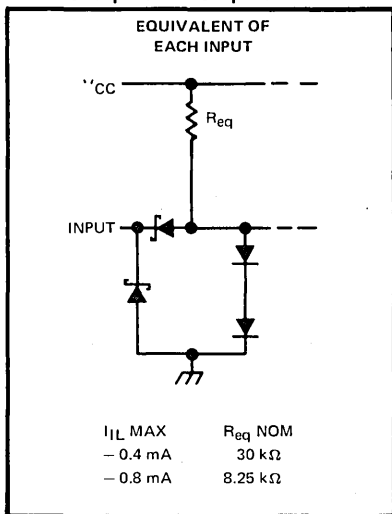

'LS113A

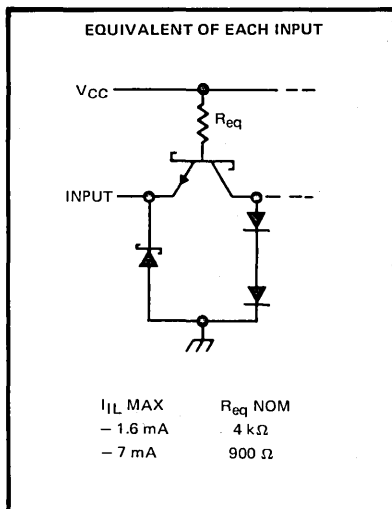
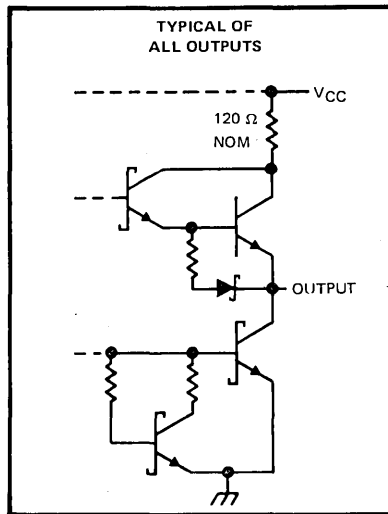

'S113

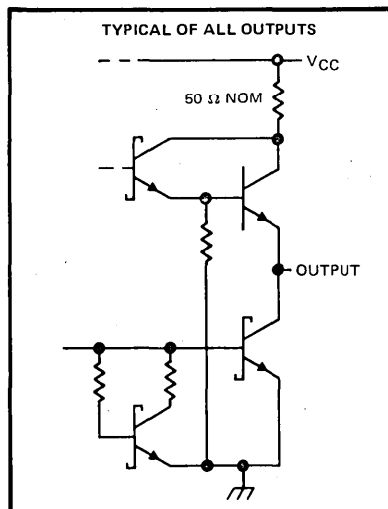

absolute maximum ratings over operating free-air temperature range (unless otherwise noted)

Supply voltage, V_{CC} (see Note 1)	7 V
Input voltage: 'LS113A	7 V
'S113	5.5 V
Operating free-air temperature range: SN54'	-55°C to 125°C
SN74'	0°C to 70°C
Storage temperature range	-65°C to 150°C

NOTE 1: Voltage values are with respect to network ground terminal.



TTL DEVICES

TYPES SN54LS113A, SN74LS113A DUAL J-K NEGATIVE-EDGE-TRIGGERED FLIP-FLOPS WITH PRESET

recommended operating conditions

	SN54LS113A			SN74LS113A			UNIT			
	MIN	NOM	MAX	MIN	NOM	MAX				
V _{CC}	Supply voltage			4.5	5	5.5	4.75	5	5.25	V
V _{IH}	High-level input voltage			2			2			V
V _{IL}	Low-level input voltage			0.7			0.8			V
I _{OH}	High-level output current			-0.4			-0.4			mA
I _{OL}	Low-level output current			4			8			mA
f _{clock}	Clock frequency			0	30		0	30		MHz
t _w	Pulse duration	CLK high		20		20				ns
		PRE or CLR low		25		25				
t _{su}	Setup time before CLK ↓	data high or low		20		20				ns
		PRE inactive		20		20				
t _h	Hold time-data after CLK ↓			0			20			ns
T _A	Operating free-air temperature			-55	125		0	70		°C

electrical characteristics over recommended operating free-air temperature range (unless otherwise noted)

PARAMETER	TEST CONDITIONS†		SN54LS113A		SN74LS113A		UNIT
			MIN	TYP‡	MAX	MIN	
V _{IK}	V _{CC} = MIN,	I _I = -18 mA	-1.5		-1.5		V
V _{OH}	V _{CC} = MIN,	V _{IH} = 2 V, V _{IL} = MAX, I _{OH} = -0.4 mA	2.5	3.4	2.7	3.4	V
V _{OL}	V _{CC} = MIN,	V _{IL} = MAX, V _{IH} = 2 V, I _{OL} = 4 mA	0.25 0.4		0.25 0.4		V
	V _{CC} = MIN,	V _{IL} = MAX, V _{IH} = 2 V, I _{OL} = 8 mA			0.35 0.5		
I _I	J or K	V _{CC} = MAX, V _I = 7 V	0.1		0.1		mA
	PRE		0.3		0.3		
	CLK		0.4		0.4		
I _{IH}	J or K	V _{CC} = MAX, V _I = 2.7 V	20		20		μA
	PRE		60		60		
	CLK		80		80		
I _{IL}	J or K	V _{CC} = MAX, V _I = 0.4 V	-0.4		-0.4		mA
	PRE or CLK		-0.8		-0.8		
I _{OS} §	V _{CC} = MAX,	see Note 4	-20	-100	-20	-100	mA
I _{CC}	V _{CC} = MAX,	see Note 2	4	6	4	6	mA

† For conditions shown as MIN or MAX, use the appropriate value specified under recommended operating conditions.

‡ All typical values are at V_{CC} = 5 V, T_A = 25°C.

§ Not more than one output should be shorted at a time, and the duration of the short circuit should not exceed one second.

NOTE 2: With all outputs open, I_{CC} is measured with the Q and \bar{Q} outputs high in turn. At the time of measurement, the clock input is grounded.

NOTE 4: For certain devices where state commutation can be caused by shorting an output to ground, an equivalent test may be performed with V_O = 2.25 V and 2.125 V for the 54 family and the 74 family, respectively, with the minimum and maximum limits reduced to one half of their stated values.

switching characteristics, V_{CC} = 5 V, T_A = 25°C (see note 3)

PARAMETER	FROM (INPUT)	TO (OUTPUT)	TEST CONDITIONS		MIN	TYP	MAX	UNIT
f _{max}			R _L = 2 kΩ,	C _L = 15 pF	30	45		MHz
t _{PLH}	PRE or CLK	Q or \bar{Q}			15	20		ns
t _{PHL}					15	20		ns

NOTE 3: See General Information Section for load circuits and voltage waveforms.

TYPES SN54S113, SN74S113 DUAL J-K NEGATIVE-EDGE-TRIGGERED FLIP-FLOPS WITH PRESET

recommended operating conditions

		SN54S113			SN74S113			UNIT
		MIN	NOM	MAX	MIN	NOM	MAX	
V _{CC}	Supply voltage	4.5	5	5.5	4.75	5	5.25	V
V _{IH}	High-level input voltage	2			2			V
V _{IL}	Low-level input voltage	0.8			0.8			V
I _{OH}	High-level output current	-1			-1			mA
I _{OL}	Low-level output current	20			20			mA
t _w	Pulse duration	CLK high	6		6			ns
		CLK low	6.5		6.5			
		PRE low	8		8			
t _{su}	Setup time before CLK ↓	3			3			ns
t _h	Hold time-data after CLK ↓	0			0			ns
T _A	Operating free-air temperature	-55			125			°C

electrical characteristics over recommended operating free-air temperature range (unless otherwise noted)

PARAMETER		TEST CONDITIONS†	SN54S113			SN74S113			UNIT
			MIN	TYP‡	MAX	MIN	TYP‡	MAX	
V _{IK}		V _{CC} = MIN, I _I = -18 mA	-1.2			-1.2			V
V _{OH}		V _{CC} = MIN, V _{IH} = 2 V, V _{IL} = 0.8 V, I _{OH} = -1 mA	2.5	3.4		2.7	3.4		V
V _{OL}		V _{CC} = MIN, I _{OL} = 20 mA, V _{IH} = 2 V, V _{IL} = 0.8 V	0.5			0.5			V
I _I		V _{CC} = MAX, V _I = 5.5 V	1			1			mA
I _{IH}	J or K	V _{CC} = MAX, V _I = 2.7 V	50			50			μA
	PRE or CLK		100			100			
I _{IL}	J or K	V _{CC} = MAX, V _I = 0.5 V	-1.6			-1.6			mA
	PRE		-7			-7			
	CLK		-4			-4			
I _{OS} §		V _{CC} = MAX	-40	-100		-40	-100	mA	
I _{CC}		V _{CC} = MAX, see Note 2	15	25		15	25	mA	

† For conditions shown as MIN or MAX, use the appropriate value specified under recommended operating conditions.

‡ All typical values are at V_{CC} = 5 V, T_A = 25°C.

§ Not more than one output should be shorted at a time, and the duration of the short circuit should not exceed one second.

NOTE 2: With all outputs open, I_{CC} is measured with the Q and Q̄ outputs high in turn. At the time of measurement, the clock input is grounded.

switching characteristics, V_{CC} = 5 V, T_A = 25°C (see note 3)

PARAMETER	FROM (INPUT)	TO (OUTPUT)	TEST CONDITIONS		MIN	TYP	MAX	UNIT
f _{max}			R _L = 280 Ω, C _L = 15 pF		80	125		MHz
t _{PLH}	PRE	Q or Q̄				4	7	ns
t _{PHL}	PRE (CLK high)	Q̄ or Q				5	7	ns
	PRE (CLK low)					5	7	
t _{PLH}	CLK	Q or Q̄				4	7	ns
t _{PHL}						5	7	ns

NOTE 3: See General Information Section for load circuits and voltage waveforms.

TYPES SN54LS114A, SN54S114, SN74LS114A, SN74S114 DUAL J-K NEGATIVE-EDGE-TRIGGERED FLIP-FLOPS WITH PRESET, COMMON CLEAR, AND COMMON CLOCK

REVISED DECEMBER 1983

- Fully Buffered to Offer Maximum Isolation from External Disturbance
- Package Options Include Both Plastic and Ceramic Carriers in Addition to Plastic and Ceramic DIPs.
- Dependable Texas Instruments Quality and Reliability

description

These devices contain two independent J-K negative-edge-triggered flip-flops. A low level at the preset and clear inputs sets or resets the outputs regardless of the levels of the other inputs. When preset and clear are inactive (high), data at the J and K inputs meeting the setup time requirements are transferred to the outputs on the negative-going edge of the clock pulse. Clock triggering occurs at a voltage level and is not directly related to the rise time of the clock pulse. Following the hold time interval, data at the J and K inputs may be changed without affecting the levels at the outputs. These versatile flip-flops can perform as toggle flip-flops by tying J and K high.

The SN54LS114A and SN54S114 are characterized for operation over the full military temperature range of -55°C to 125°C . The SN74LS114A and SN74S114 are characterized for operation from 0°C to 70°C .

FUNCTION TABLE

INPUTS					OUTPUTS	
PRE	CLR	CLK	J	K	Q	\bar{Q}
L	H	X	X	X	H	L
H	L	X	X	X	L	H
L	L	X	X	X	H \dagger	H \dagger
H	H	\downarrow	L	L	Q $_0$	Q $_0$
H	H	\downarrow	H	L	H	L
H	H	\downarrow	L	H	L	H
H	H	\downarrow	H	H	TOGGLE	TOGGLE
H	H	H	X	X	Q $_0$	Q $_0$

\dagger The output levels in this configuration are not guaranteed to meet the minimum levels for V_{OH} if the lows at preset and clear are near V_{IL} minimum. Furthermore, this configuration is nonstable; that is, it will not persist when either preset or clear returns to its inactive (high) level.

SN54LS114A, SN54S114 ... J OR W PACKAGE
SN74LS114A, SN74S114 ... D, J OR N PACKAGE
(TOP VIEW)

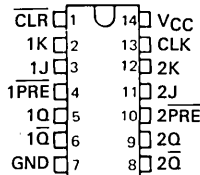

SN54LS114A, SN54S114 ... FK PACKAGE
SN74LS114A, SN74S114 ... FN PACKAGE
(TOP VIEW)

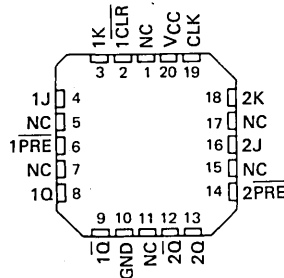

NC - No internal connection

logic symbol

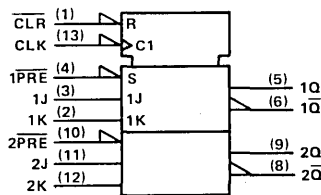

Pin numbers shown on logic notation are for D, J or N packages.

PRODUCTION DATA

This document contains information current as of publication date. Products conform to specifications per the terms of Texas Instruments standard warranty. Production processing does not necessarily include testing of all parameters.

TEXAS
INSTRUMENTS

POST OFFICE BOX 225012 • DALLAS, TEXAS 75265

TYPES SN54LS114A, SN54S114, SN74LS114A, SN74S114
 DUAL J-K NEGATIVE-EDGE-TRIGGERED FLIP-FLOPS
 WITH PRESET, COMMON CLEAR, AND COMMON CLOCK

logic diagram

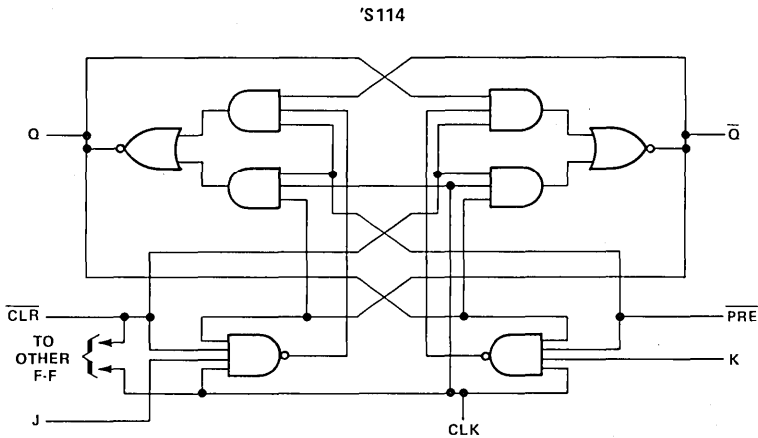
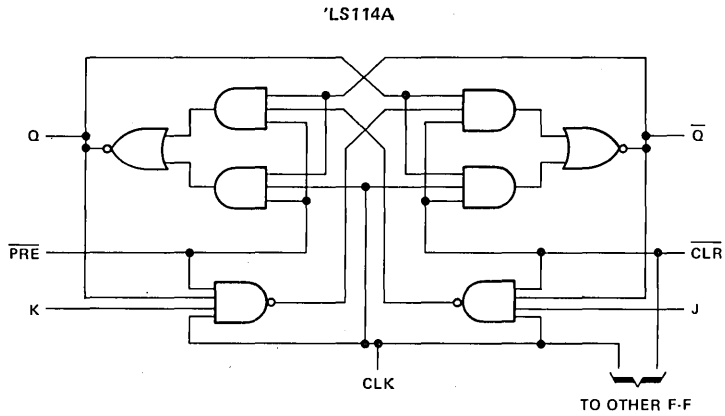

TYPES SN54LS114A, SN54S114, SN74LS114A, SN74S114 DUAL J-K NEGATIVE-EDGE-TRIGGERED FLIP-FLOPS WITH PRESET, COMMON CLEAR, AND COMMON CLOCK

schematics of inputs and outputs

'LS114A

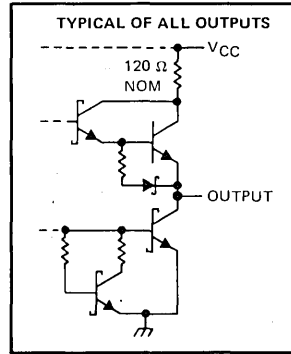
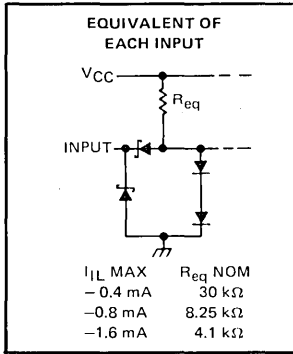

'S114

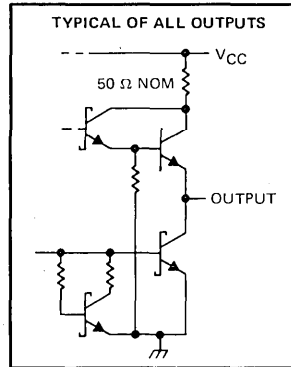
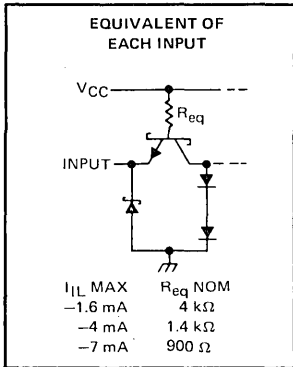

absolute maximum ratings over operating free-air temperature range (unless otherwise noted)

Supply voltage, V_{CC} (see Note 1)	7 V
Input voltage: 'LS114A	7 V
'S114	5.5 V
Operating free-air temperature range: SN54'	-55°C to 125°C
SN74'	0°C to 70°C
Storage temperature range	-65°C to 150°C

NOTE 1: Voltage values are with respect to network ground terminal.

3

TTL DEVICES

**TYPES SN54LS114A, SN74LS114A
DUAL J-K NEGATIVE-EDGE-TRIGGERED FLIP-FLOPS
WITH PRESET, COMMON CLEAR, AND COMMON CLOCK**

recommended operating conditions

		SN54LS114A			SN74LS114A			UNIT		
		MIN	NOM	MAX	MIN	NOM	MAX			
V _{CC}	Supply voltage	4.5	5	5.5	4.75	5	5.25	V		
V _{IH}	High-level input voltage	2			2			V		
V _{IL}	Low-level input voltage				0.7			0.8	V	
I _{OH}	High-level output current				-0.4			-0.4	mA	
I _{OL}	Low-level output current				4			8	mA	
f _{clock}	Clock frequency	0			30			0	30	MHz
t _w	Pulse duration	CLK			20			20	ns	
		PRE or CLR low			25			25		
t _{su}	Set up time-before CLK ↓	data high or low			20			20	ns	
		CLR inactive			25			25		
		PRE inactive			20			20		
t _h	Hold time-data after CLK ↓	0			0			0	ns	
T _A	Operating free-air temperature	-55			125			0	70	°C

electrical characteristics over recommended operating free-air temperature range (unless otherwise noted)

PARAMETER		TEST CONDITIONS†		SN54LS114A		SN74LS114A		UNIT
				MIN	TYP‡	MAX	MIN	
V _{IK}		V _{CC} = MIN, I _I = -18 mA		-1.5		-1.5		V
V _{OH}		V _{CC} = MIN, V _{IH} = 2 V, V _{IL} = MAX, I _{OH} = -0.4 mA		2.5	3.4	2.7	3.4	V
V _{OL}		V _{CC} = MIN, V _{IL} = MAX, V _{IH} = 2 V, I _{OL} = 4 mA		0.25	0.4	0.25	0.4	V
		V _{CC} = MIN, V _{IL} = MAX, V _{IH} = 2 V, I _{OL} = 8 mA				0.35	0.5	
I _I	J or K	V _{CC} = MAX, V _I = 7 V		0.1		0.1		mA
	CLR			0.6		0.6		
	PRE			0.3		0.3		
	CLK			0.8		0.8		
I _{IH}	J or K	V _{CC} = MAX, V _I = 2.7 V		20		20		μA
	CLR			120		120		
	PRE			60		60		
	CLK			160		160		
I _{IL}	J or K	V _{CC} = MAX, V _I = 0.4 V		-0.4		-0.4		mA
	CLR			-1.6		-1.6		
	PRE			-0.8		-0.8		
	CLK			-1.6		-1.6		
I _{OS} §		V _{CC} = MAX, see Note 4		-20	-100	-20	-100	mA
I _{CC}		V _{CC} = MAX, see Note 2		4	6	4	6	mA

† For conditions shown as MIN or MAX, use the appropriate value specified under recommended operating conditions.

‡ All typical values are at V_{CC} = 5 V, T_A = 25°C.

§ Not more than one output should be shorted at a time, and the duration of the short circuit should not exceed one second.

NOTE 2: With all outputs open, I_{CC} is measured with the Q and Q̄ outputs high in turn. At the time of measurement, the clock input is grounded.

NOTE 4: For certain devices where state commutation can be caused by shorting an output to ground, an equivalent test may be performed with V_O = 2.25 V and 2.125 V for the '54 family and the '74 family, respectively, with the minimum and maximum limits reduced to one half of their stated values.

TYPES SN54LS114A, SN74LS114A
**DUAL J-K NEGATIVE-EDGE-TRIGGERED FLIP-FLOPS
 WITH PRESET, COMMON CLEAR, AND COMMON CLOCK**

switching characteristics, $V_{CC} = 5\text{ V}$, $T_A = 25^\circ\text{C}$ (see note 3)

PARAMETER	FROM (INPUT)	TO (OUTPUT)	TEST CONDITIONS	MIN	TYP	MAX	UNIT
f_{\max}			$R_L = 2\text{ k}\Omega$, $C_L = 15\text{ pF}$	30	45		MHz
t_{PLH}	$\overline{\text{CLR}}$, $\overline{\text{PRE}}$ or CLK	Q or $\overline{\text{Q}}$		15	20		ns
t_{PHL}				15	20		ns

NOTE 3: See General Information Section for load circuits and voltage waveforms.

TYPES SN54S114, SN74S114

DUAL J-K NEGATIVE-EDGE-TRIGGERED FLIP-FLOPS

WITH PRESET, COMMON CLEAR, AND COMMON CLOCK

recommended operating conditions

	SN54S114			SN74S114			UNIT
	MIN	NOM	MAX	MIN	NOM	MAX	
V _{CC} Supply voltage	4.5	5	5.5	4.75	5	5.25	V
V _{IH} High-level input voltage	2			2			V
V _{IL} Low-level input voltage	0.8			0.8			V
I _{OH} High-level output current	-1			-1			mA
I _{OL} Low-level output current	20			20			mA
t _w Pulse duration	CLK high		6	6		ns	
	CLK low		6.5	6.5			
	CLR or PRE low		8	8			
t _{su} Setup time	data high or low		3	3		ns	
t _h Hold time-data after CLK↓			0	0		ns	
T _A Operating free-air temperature	-55		125	0		70	°C

electrical characteristics over recommended operating free-air temperature range (unless otherwise noted)

PARAMETER	TEST CONDITIONS†		SN54S114		SN74S114		UNIT
			MIN	TYP‡	MAX	MIN	
V _{IK}	V _{CC} = MIN, I _I = -18 mA		-1.2		-1.2		V
V _{OH}	V _{CC} = MIN, V _{IH} = 2 V, V _{IL} = 0.8 V, I _{OH} = -1 mA		2.5	3.4	2.7	3.4	V
V _{OL}	V _{CC} = MIN, V _{IH} = 2 V, V _{IL} = 0.8 V, I _{OL} = 20 mA		0.5		0.5		V
I _I	V _{CC} = MAX, V _I = 5.5 V		1		1		mA
I _{IH}	J or K	V _{CC} = MAX, V _I = 2.7 V	50		50		μA
	CLR		200		200		
	PRE		100		100		
	CLK		200		200		
I _{IL}	J or K	V _{CC} = MAX, V _I = 0.5 V	-1.6		-1.6		mA
	CLR		-14		-14		
	PRE		-7		-7		
	CLK		-8		-8		
I _{OS} §	V _{CC} = MAX		-40	-100	-40	-100	mA
I _{CC}	V _{CC} = MAX, see Note 2		15	25	15	25	mA

† For conditions shown as MIN or MAX, use the appropriate value specified under recommended operating conditions.

‡ All typical values are at V_{CC} = 5 V, T_A = 25°C.

§ Not more than one output should be shorted at a time, and the duration of the short circuit should not exceed one second.

NOTE 2: With all outputs open, I_{CC} is measured with the Q and \bar{Q} outputs high in turn. At the time of measurement, the clock input is grounded.

switching characteristics, V_{CC} = 5 V, T_A = 25°C (see note 3)

PARAMETER	FROM (INPUT)	TO (OUTPUT)	TEST CONDITIONS		MIN	TYP	MAX	UNIT
f _{max}			R _L = 280 Ω, C _L = 15 pF		80	125		MHz
t _{PLH}	\bar{PRE} or \bar{CLR}	Q or \bar{Q}			4	7		ns
t _{PHL}	\bar{PRE} or \bar{CLR} (CLK high)	\bar{Q} or Q			5	7		ns
	\bar{PRE} or \bar{CLR} (CLK low)				5	7		ns
t _{PLH}	CLK	Q or \bar{Q}			4	7		ns
t _{PHL}					5	7		ns

NOTE 3: See General Information Section for load circuits and voltage waveforms.

TYPES SN54116, SN74116 DUAL 4-BIT LATCHES WITH CLEAR

DECEMBER 1972—REVISED DECEMBER 1983

- Two Independent 4-Bit Latches in a Single Package
- Separate Clear Inputs Provide One-Step Clearing Operation
- Dual Gated Enable Inputs Simplify Cascading Register Implementations
- Compatible for Use with TTL Circuits
- Input Clamping Diodes Simplify System Design

SN54116 . . . J OR W PACKAGE
SN74116 . . . J OR N PACKAGE
(TOP VIEW)

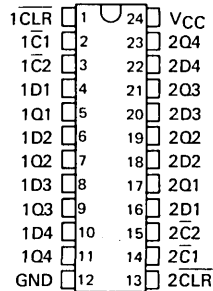

description

These monolithic TTL circuits utilize D-type bistables to implement two independent four-bit latches in a single package. Each four-bit latch has an independent asynchronous clear input and a gated two-input enable circuit. When both enable inputs are low, the output levels will follow the data input levels. When either or both of the enable inputs are taken high, the outputs remain at the last levels setup at the inputs prior to the low-to-high-level transition at the enable input(s). After this, the data inputs are locked out.

The clear input is overriding and when taken low will reset all four outputs low regardless of the levels of the enable inputs.

The SN54116 is characterized for operation over the full military temperature range of -55°C to 125°C ; the SN74116 is characterized for operation from 0°C to 70°C .

FUNCTION TABLE
(EACH LATCH)

CLEAR	ENABLE		DATA	OUTPUT Q
	C1	C2		
H	L	L	L	L
H	L	L	H	H
H	X	H	X	Q_0
H	H	X	X	Q_0
L	X	X	X	L

H - high level, L - low level, X - irrelevant
 Q_0 - the level of Q before these input conditions were established.

PRODUCTION DATA
This document contains information current as of publication date. Products conform to specifications per the terms of Texas Instruments standard warranty. Production processing does not necessarily include testing of all parameters.

**TEXAS
INSTRUMENTS**

POST OFFICE BOX 225012 • DALLAS, TEXAS 75265

TYPES SN54116, SN74116 DUAL 4-BIT LATCHES WITH CLEAR

logic diagram

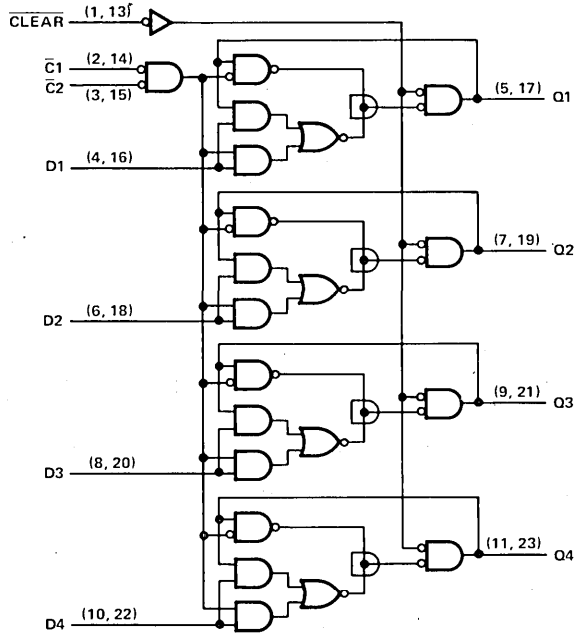

Pin numbers shown on logic notation are for J or N packages.

3

TTL DEVICES

schematics of inputs and outputs

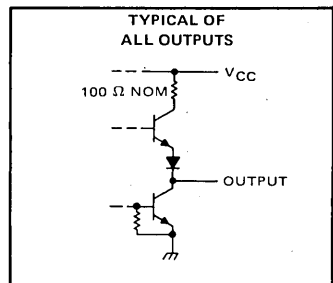
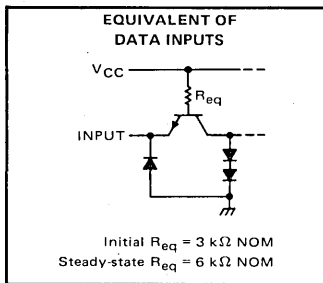
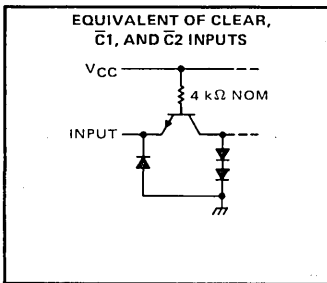

absolute maximum ratings over operating free-air temperature range (unless otherwise noted)

Supply voltage, V_{CC} (see Note 1)	7 V
Input voltage	5.5 V
Operating free-air temperature range: SN54116 Circuits	-55°C to 125°C
SN74116 Circuits	0°C to 70°C
Storage temperature range	-65°C to 150°C

NOTE 1: Voltage values are with respect to network ground terminal.

TYPES SN54116, SN74116 DUAL 4-BIT LATCHES WITH CLEAR

recommended operating conditions

	SN54116			SN74116			UNIT	
	MIN	NOM	MAX	MIN	NOM	MAX		
Supply voltage, V_{CC}	4.5	5	5.5	4.75	5	5.25	V	
High-level output current, I_{OH}			-800			-800	μ A	
Low-level output current, I_{OL}			16			16	mA	
Input pulse width, t_w	$\bar{C}1, \bar{C}2$		18			18	ns	
	\bar{CLR}		18			18		
Data setup time, t_{su}	High logic level		8			8	ns	
	Low logic level		14			14		
Clear inactive-state setup time, t_{su}			8			8	ns	
Data release time, high-level data, $t_{release}$					2		2	
Data hold time, low-level data, t_h			8			8	ns	
Operating free-air temperature, T_A			-55		125	0	70	$^{\circ}$ C

electrical characteristics over recommended operating free-air temperature range (unless otherwise noted)

PARAMETER		TEST CONDITIONS [†]	MIN	TYP [‡]	MAX	UNIT
V_{IH}	High-level input voltage		2			V
V_{IL}	Low-level input voltage				0.8	V
V_{IK}	Input clamp voltage	$V_{CC} = \text{MIN}, I_I = -12 \text{ mA}$			-1.5	V
V_{OH}	High-level output voltage	$V_{CC} = \text{MIN}, V_{IH} = 2 \text{ V}, V_{IL} = 0.8 \text{ V}, I_{OH} = -800 \mu\text{A}$	2.4	3.4		V
V_{OL}	Low-level output voltage	$V_{CC} = \text{MIN}, V_{IH} = 2 \text{ V}, V_{IL} = 0.8 \text{ V}, I_{OL} = 16 \text{ mA}$		0.2	0.4	V
I_I	Input current at maximum input voltage	$V_{CC} = \text{MAX}, V_I = 5.5 \text{ V}$			1	mA
I_{IH}	High-level input current	$\bar{C}1, \bar{C}2$, or clear	$V_{CC} = \text{MAX}, V_I = 2.4 \text{ V}$		40	μ A
		Any D		60		
I_{IL}	Low-level input current	$\bar{C}1, \bar{C}2$, or clear	$V_{CC} = \text{MAX}, V_I = 0.4 \text{ V}$		-1.6	mA
		Any D, initial peak			-2.4	
		Any D, steady-state			-1.6	
I_{OS}	Short-circuit output current [§]	$V_{CC} = \text{MAX}$	SN54116	-20	-57	mA
			SN74116	-18	-57	
I_{CC}	Supply current	$V_{CC} = \text{MAX},$ See Note 2	Condition A	60	100	mA
			Condition B	40	70	

[†]For conditions shown as MIN or MAX, use the appropriate value specified under recommended operating conditions for the applicable device type.

[‡]All typical values are at $V_{CC} = 5 \text{ V}, T_A = 25^{\circ}\text{C}$.

[§]Not more than one output should be shorted at a time.

NOTE 2: With outputs open, I_{CC} is measured for the following conditions:

- A. All inputs grounded.
- B. All \bar{C} inputs are grounded and all other inputs are at 4.5 V.

switching characteristics, $V_{CC} = 5 \text{ V}, T_A = 25^{\circ}\text{C}$

PARAMETER	FROM (INPUT)	TO (OUTPUT)	TEST CONDITIONS	MIN	TYP	MAX	UNIT
t_{PLH}	$\bar{C}1$ or $\bar{C}2$	Any Q	$C_L = 15 \text{ pF},$ $R_L = 400 \Omega,$ See Figure 1		19	30	ns
t_{PHL}					15	22	
t_{PLH}	Data	Q			10	15	ns
t_{PHL}					12	18	
t_{PHL}	\bar{CLR}	Any Q			15	22	ns

3

TTL DEVICES

TYPES SN54116, SN74116
 DUAL 4-BIT LATCHES WITH CLEAR

PARAMETER MEASUREMENT INFORMATION

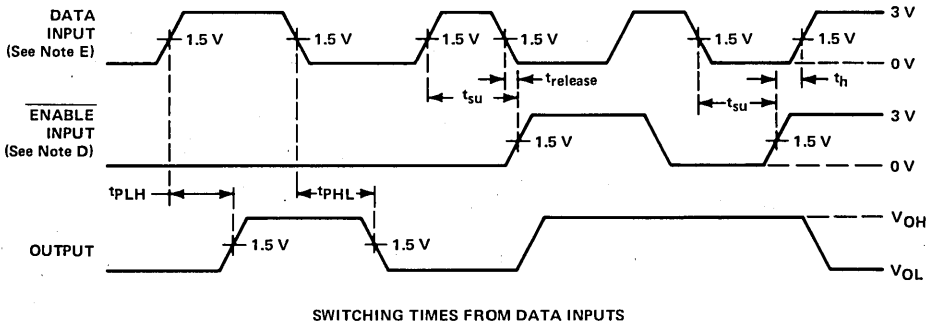
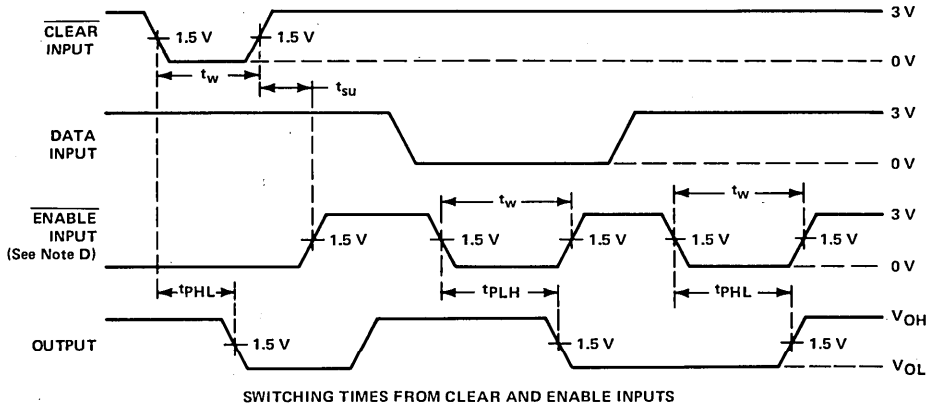
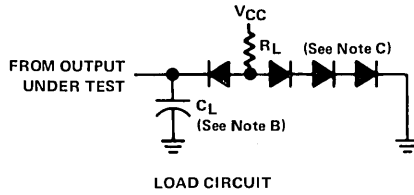

- NOTES: A. Input pulses are supplied by generators having the following characteristics: $t_r \leq 10$ ns, $t_f \leq 10$ ns, PRR = 1 MHz, duty cycle $\leq 50\%$, $Z_{out} \approx 50\Omega$.
 B. C_L includes probe and jig capacitance.
 C. All diodes are 1N3064 or equivalent.
 D. The other enable input is low.
 E. Clear input is high.

FIGURE 1

3

TTL DEVICES

TYPES SN54120, SN74120 DUAL PULSE SYNCHRONIZERS/DRIVERS

SEPTEMBER 1971—REVISED DECEMBER 1983

- Generates Either a Single Pulse or Train of Pulses Synchronized with Control Functions
- Ideal for Implementing Sync-Control Circuits Similar to those Used in Oscilloscopes
- Latched Operation Ensures that Output Pulses Are Not Clipped
- High-Fan-Out Complementary Outputs Drive System Clock Lines Directly
- Internal Input Pull-Up Resistors Eliminate Need for External Components
- Diode-Clamped Inputs Simplify System Design
- Typical Propagation Delays:

9 Nanoseconds through One Level
16 Nanoseconds through Two Levels

SN54120 . . . J OR W PACKAGE
SN74120 . . . J OR N PACKAGE
(TOP VIEW)

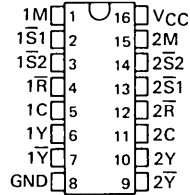

description

These monolithic pulse synchronizers are designed to synchronize an asynchronous or manual signal with a system clock. Reliable response is ensured as the input signals are latched up; therefore duration of logic input is not critical and the adverse effects of contact-bounce of a manual input are eliminated. The ability to pass output pulses is started and stopped by the levels or pulses applied to the latch inputs $\bar{S}1$, $\bar{S}2$, or \bar{R} in accordance with the function table. High-speed circuitry is utilized throughout the clock paths to minimize skew with respect to the system clock.

After initiation, the mode control (M) input determines whether a series of pulses or only one pulse is passed. In the absence of a stop command, the clock driver will continue to pass clock pulses as long as the mode control input is low (see Figures 2 through 4). If the mode control input is high only a single clock pulse will be passed (see Figure 5).

When the mode control is set to pass a series of pulses, the last pulse out is determined by two general rules:

- When pulses are terminated by the \bar{S} or \bar{R} inputs, conditions meeting the setup times (specified under recommended operating conditions) will dominate.
- Low-to-high-level transitions at the mode control input should be avoided during the 20-nanosecond period immediately following the negative transition of the input clock pulse as transitions during this time period may or may not allow the next pulse to pass (see Figures 4 and 5). When pulses are terminated by the mode control input, a positive transition at the mode control input meeting the high-level setup time, $t_{SU}(H)$, (specified under recommended operating conditions) will pass that positive clock pulse then inhibit remaining clock pulses. The clock input (C) is latch-controlled ensuring that once initiated the output pulse will not be terminated until the full pulse has been passed.

FUNCTION TABLE

INPUTS			FUNCTION
\bar{R}	$\bar{S}1$	$\bar{S}2$	
X	L	X	Pass Output Pulses
X	X	L	Pass Output Pulses
L	H	H	Inhibit Output Pulses
H	↓	H	Start Output Pulses
H	H	↓	Start Output Pulses
↓	H	H	Stop Output Pulses
H	H	H	Continue [†]

H = high level (steady state)

L = low level (steady state)

↓ = transition from H to L

X = irrelevant

[†] Operation initiated by last ↓ transition continues.

PRODUCTION DATA

This document contains information current as of publication date. Products conform to specifications per the terms of Texas Instruments standard warranty. Production processing does not necessarily include testing of all parameters.

TEXAS
INSTRUMENTS

POST OFFICE BOX 225012 • DALLAS, TEXAS 75265

3

TTL DEVICES

TYPES SN54120, SN74120 DUAL PULSE SYNCHRONIZERS/DRIVERS

description (continued)

This clock driver circuit is entirely compatible for use with either digital logic circuits or mechanical switches for input controls since all inputs, except the clock, have internal pull-up resistors. This eliminates the requirement to supply an external resistor to prevent the input from floating when the control switch is open. The internal resistor also means that these inputs may be left disconnected if unused.

Typical propagation delay time is 9 nanoseconds to the \bar{Y} output and 16 nanoseconds to the Y output from the clock input. The outputs will drive 60 Series 54/74 loads at a high logic level and 30 loads at a low logic level. Typical power dissipation is 127 milliwatts per driver. The SN54120 is characterized for operation from -55°C to 125°C ; the SN74120 is characterized for operation from 0°C to 70°C .

logic diagram (each driver)

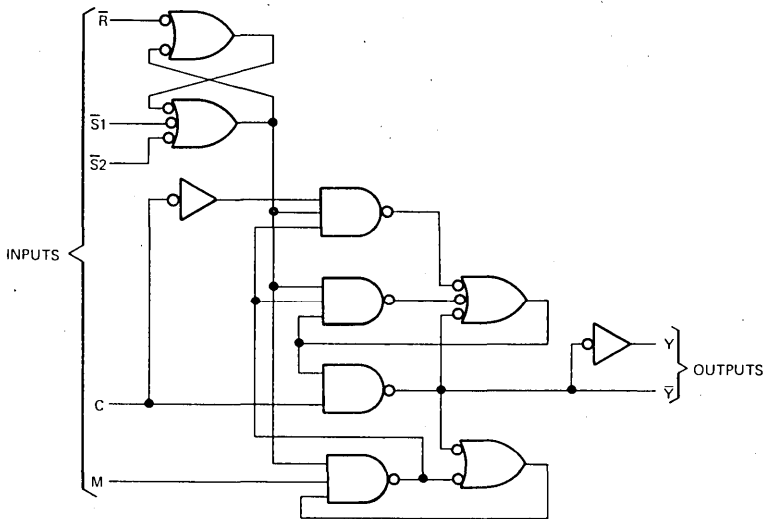

schematics of inputs and outputs

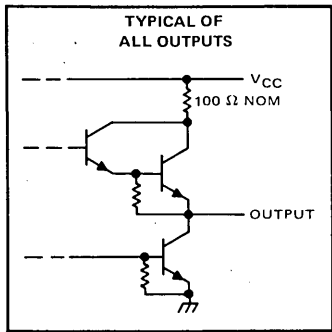
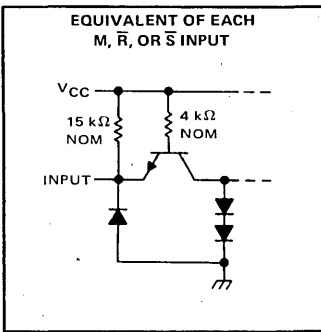
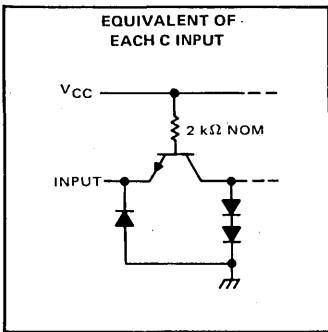

TTL DEVICES

TYPES SN54120, SN74120 DUAL PULSE SYNCHRONIZERS/DRIVERS

absolute maximum ratings over operating free-air temperature range (unless otherwise noted)

Supply voltage, V_{CC} (see Note 1)	7 V
Input voltage	5.5 V
Interemitter voltage (see Note 2)	5.5 V
Operating free-air temperature range: SN54120 Circuits	-55°C to 125°C
SN74120 Circuits	0°C to 70°C
Storage temperature range	-65°C to 150°C

NOTES: 1. Voltage values, except interemitter voltage, are with respect to network ground terminal.

2. This is the voltage between two emitters of a multiple-emitter transistor. For this circuit, this rating applies between the S1 and S2 inputs.

recommended operating conditions

		SN54120			SN74120			UNIT		
		MIN	NOM	MAX	MIN	NOM	MAX			
Supply voltage, V_{CC}		4.5	5	5.5	4.75	5	5.25	V		
High-level output current, I_{OH}					-2.4			mA		
Low-level output current, I_{OL}					48			mA		
Setup time (see Figures 2 thru 5)	Any input except mode control, $t_{su}(H \text{ or } L)$	12			12			ns		
	Mode control	$t_{su}(H)$	0			0				
		$t_{su}(L)$	12			12				
Hold time (see Figures 3 and 5)	Any input except mode control, $t_h(H \text{ or } L)$	3			3			ns		
	Mode control, $t_h(H \text{ or } L)$	20			20					
Operating free-air temperature, T_A		-55			125			0	70	°C

electrical characteristics over recommended operating free-air temperature range (unless otherwise noted)

PARAMETER		TEST CONDITIONS†	MIN	TYP‡	MAX	UNIT	
V_{IH}	High-level input voltage		2			V	
V_{IL}	Low-level input voltage				0.8	V	
V_{IK}	Input clamp voltage	$V_{CC} = \text{MIN}, I_I = -12 \text{ mA}$			-1.5	V	
V_{OH}	High-level output voltage	$V_{CC} = \text{MIN}, V_{IH} = 2 \text{ V}, V_{IL} = 0.8 \text{ V}, I_{OH} = -2.4 \text{ mA}$	2.4	3.4		V	
V_{OL}	Low-level output voltage	$V_{CC} = \text{MIN}, V_{IH} = 2 \text{ V}, V_{IL} = 0.8 \text{ V}, I_{OL} = 48 \text{ mA}$	0.2		0.4	V	
I_I	Input current at maximum input voltage	$V_{CC} = \text{MAX}, V_I = 5.5 \text{ V}$			1	mA	
I_{IH}	High-level input current	Clock input			80	μA	
		Other inputs	$V_{CC} = \text{MAX}, V_I = 2.4 \text{ V}$	-0.12	-0.2	-0.36	mA
I_{IL}	Low-level input current	Clock input			-3.2	mA	
		Other inputs	$V_{CC} = \text{MAX}, V_I = 0.4 \text{ V}$			-2.1	mA
I_{OS}	Short-circuit output current§	$V_{CC} = \text{MAX}$			-35	-90	mA
I_{CC}	Supply current	$V_{CC} = \text{MAX}, \text{ See Note 3}$			51	90	mA

† For conditions shown as MIN or MAX, use the appropriate value specified under recommended operating conditions.

‡ All typical values are at $V_{CC} = 5 \text{ V}, T_A = 25^\circ\text{C}$.

§ Not more than one output should be shorted at a time.

NOTE 3: I_{CC} is measured with ground applied to all inputs except R which is at 4.5 V and all outputs open.

switching characteristics, $V_{CC} = 5 \text{ V}, T_A = 25^\circ\text{C}$

PARAMETER¶	FROM (INPUT)	TO (OUTPUT)	TEST CONDITIONS	MIN	TYP	MAX	UNIT
t_{PLH}	C	Y	$C_L = 45 \text{ pF}, R_L = 133 \Omega, \text{ See Figure 1}$	14		22	ns
t_{PHL}				17		25	
t_{PLH}	C	\bar{Y}		10		16	ns
t_{PHL}				8		13	

¶ t_{PLH} = Propagation delay time, low-to-high-level output

t_{PHL} = Propagation delay time, high-to-low-level output

3

TTL DEVICES

TYPES SN54120, SN74120
DUAL PULSE SYNCHRONIZERS/DRIVERS

PARAMETER MEASUREMENT INFORMATION

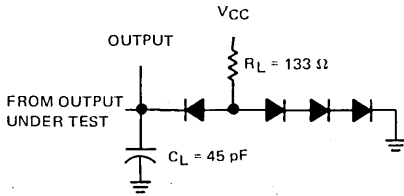

- NOTES: A. The clock input pulse in figures 2 through 5 is supplied by a generator having the following characteristics: $t_w(\text{clock}) \geq 15 \text{ ns}$, $\text{PRR} \leq 1 \text{ MHz}$, and $Z_{\text{out}} \approx 50 \Omega$.
 B. C_L includes probe and jig capacitance.
 C. All diodes are 1N3064 or equivalent.

FIGURE 1—LOAD CIRCUIT FOR SWITCHING TESTS

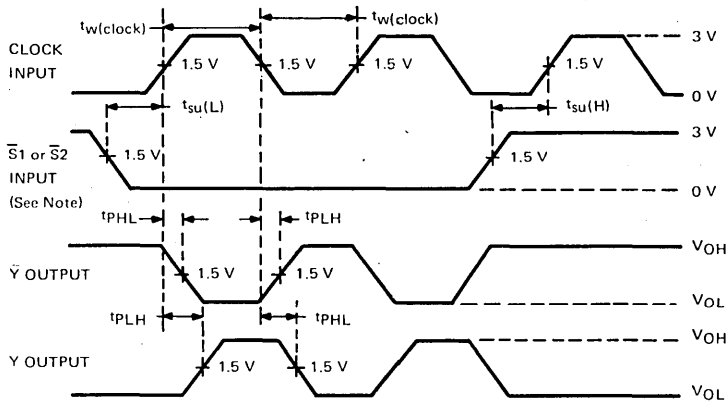

NOTE: Mode control and \bar{R} inputs are low and unused \bar{S} input is high.

FIGURE 2—INITIATING AND TERMINATING PULSE TRAIN FROM S INPUTS

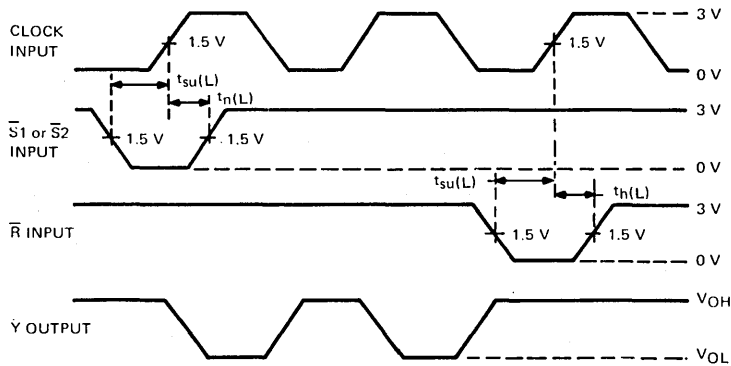

NOTE: Mode control input is low and unused \bar{S} input is high.

FIGURE 3—INITIATING PULSE TRAIN FROM S AND TERMINATING WITH R INPUTS

PARAMETER MEASUREMENT INFORMATION

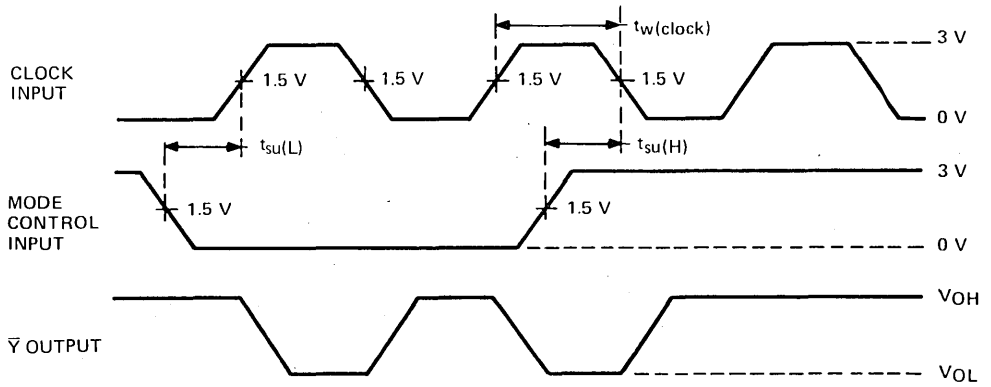

NOTE: At least one of the \bar{S} inputs is low.

FIGURE 4—INITIATING AND TERMINATING PULSE TRAIN WITH MODE CONTROL INPUT

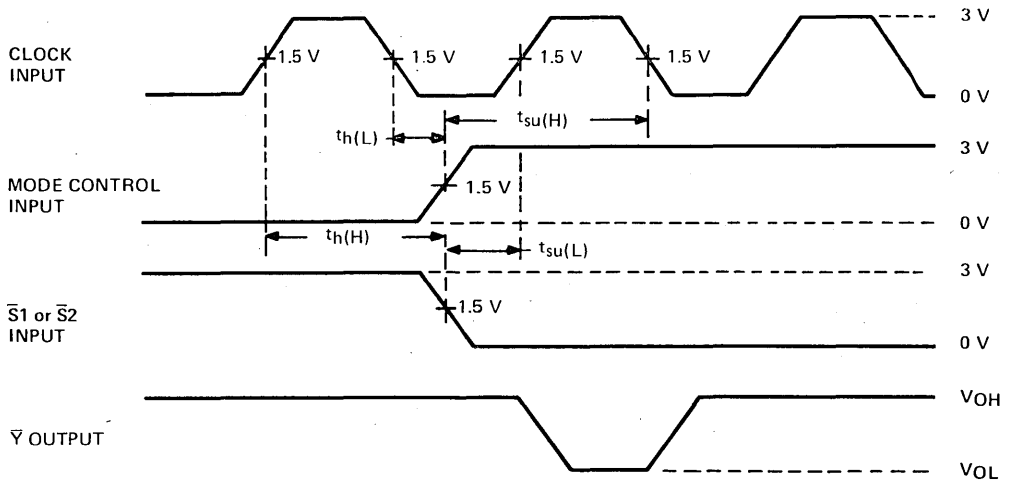

NOTE: Input \bar{R} is low and the unused \bar{S} input is high.

FIGURE 5—ENABLING SINGLE PULSE

3

TTL DEVICES

TYPES SN54121, SN54L121, SN74121 MONOSTABLE MULTIVIBRATORS WITH SCHMITT-TRIGGER INPUTS

REVISED MAY 1983

- Programmable Output Pulse Width
With R_{int} . . . 35 ns Typ
With R_{ext}/C_{ext} . . . 40 ns to 28 Seconds
- Internal Compensation for Virtual Temperature Independence
- Jitter-Free Operation up to 90% Duty Cycle
- Inhibit Capability

SN54121 . . . J OR W PACKAGE
SN54L121 . . . J PACKAGE
SN74121 . . . J OR N PACKAGE

(TOP VIEW)

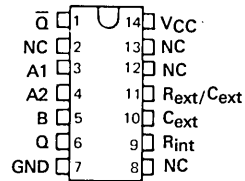

NC - No internal connection.

FUNCTION TABLE

INPUTS			OUTPUTS	
A1	A2	B	Q	Q̄
L	X	H	L	H
X	L	H	L†	H†
X	X	L	L†	H†
H	H	X	L†	H†
H	↓	H		
↓	H	H		
↓	↓	H		
L	X	↑		
X	L	↑		

For explanation of function table symbols, see page

† These lines of the function table assume that the indicated steady-state conditions at the A and B inputs have been setup long enough to complete any pulse started before the setup.

description

These multivibrators feature dual negative-transition-triggered inputs and a single positive-transition-triggered input which can be used as an inhibit input. Complementary output pulses are provided.

Pulse triggering occurs at a particular voltage level and is not directly related to the transition time of the input pulse. Schmitt-trigger input circuitry (TTL hysteresis) for the B input allows jitter-free triggering from inputs with transition rates as slow as 1 volt/second, providing the circuit with an excellent noise immunity of typically 1.2 volts. A high immunity to V_{CC} noise of typically 1.5 volts is also provided by internal latching circuitry.

Once fired, the outputs are independent of further transitions of the inputs and are a function only of the timing components. Input pulses may be of any duration relative to the output pulse. Output pulse length may be varied from 40 nanoseconds to 28 seconds by choosing appropriate timing components. With no external timing components (i.e., R_{int} connected to V_{CC} , C_{ext} and R_{ext}/C_{ext} open), an output pulse of typically 30 or 35 nanoseconds is achieved which may be used as a d-c triggered reset signal. Output rise and fall times are TTL compatible and independent of pulse length.

Pulse width stability is achieved through internal compensation and is virtually independent of V_{CC} and temperature. In most applications, pulse stability will only be limited by the accuracy of external timing components.

Jitter-free operation is maintained over the full temperature and V_{CC} ranges for more than six decades of timing capacitance (10 pF to 10 μ F) and more than one decade of timing resistance (2 k Ω to 30 k Ω for the SN54121/SN54L121 and 2 k Ω to 40 k Ω for the SN74121). Throughout these ranges, pulse width is defined by the relationship $t_{W(out)} = C_{ext}R_{T} \ln 2 \approx 0.7 C_{ext}R_{T}$. In circuits where pulse cutoff is not critical, timing capacitance up to 1000 μ F and timing resistance as low as 1.4 k Ω may be used. Also, the range of jitter-free output pulse widths is extended if V_{CC} is held to 5 volts and free-air temperature is 25°C. Duty cycles as high as 90% are achieved when using maximum recommended R_{T} . Higher duty cycles are available if a certain amount of pulse-width jitter is allowed.

PRODUCTION DATA
This document contains information current as of publication date. Products conform to specifications per the terms of Texas Instruments standard warranty. Production processing does not necessarily include testing of all parameters.

TEXAS INSTRUMENTS

POST OFFICE BOX 225012 • DALLAS, TEXAS 75265

3-471

3

TTL DEVICES

TYPES SN54121, SN54L121, SN74121 MONOSTABLE MULTIVIBRATORS WITH SCHMITT-TRIGGER INPUTS

logic diagram (positive logic)

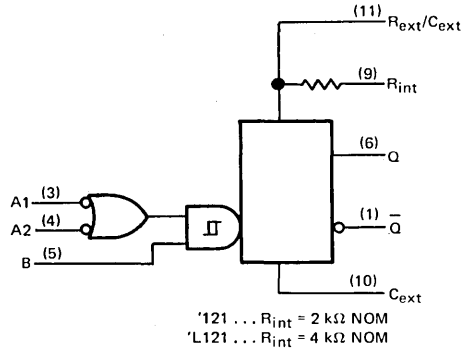

Pin numbers shown on logic notation are for J or N packages.

- NOTES:
1. An external capacitor may be connected between C_{ext} (positive) and R_{ext}/C_{ext} .
 2. To use the internal timing resistor, connect R_{int} to V_{CC} . For improved pulse width accuracy and repeatability, connect an external resistor between R_{ext}/C_{ext} and V_{CC} with R_{int} open-circuited.

schematics of inputs and outputs

3 TTL DEVICES

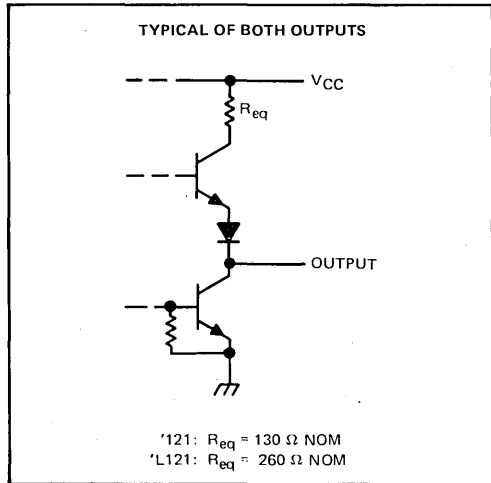
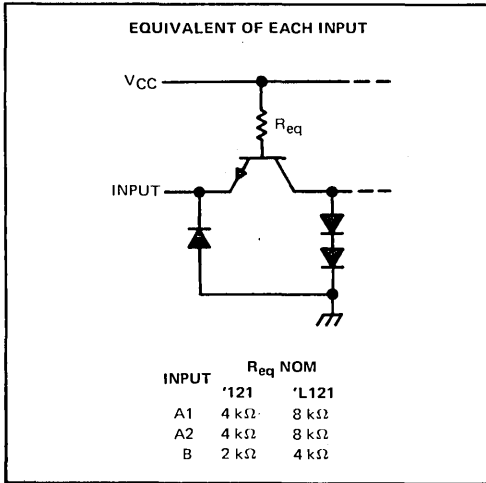

TYPES SN54121, SN54L121, SN74121 MONOSTABLE MULTIVIBRATORS WITH SCHMITT-TRIGGER INPUTS

absolute maximum ratings over operating free-air temperature range (unless otherwise noted)

Supply voltage, V_{CC} (see Note 1) '121.....	7 V
'L121.....	8 V
Input voltage:.....	5.5 V
Operating free-air temperature range: SN54121, SN54L121	- 55°C to 125°C
SN74121	0°C to 70°C
Storage temperature range	- 65°C to 150°C

NOTE 1: Voltage values are with respect to network ground terminal.

recommended operating conditions

		SN54121 SN74121			SN54L121			UNIT
		MIN	NOM	MAX	MIN	NOM	MAX	
V_{CC} Supply voltage	54 Family	4.5	5	5.5	4.5	5	5.5	V
	74 Family	4.75	5	5.25				
I_{OH} High-level output current				- 0.4			- 0.2	mA
I_{OL} Low-level output current						16	8	mA
dv/dt Rate of rise or fall of input pulse	Schmitt input, B		1			1		V/s
	Logic inputs, A1, A2		1			1		V/ μ s
$t_w(in)$ Input pulse width			50			100		ns
R_{ext} External timing capacitance	54 Family		1.4	30		1.4	30	k Ω
	74 Family		1.4	40				
C_{ext} External timing capacitance			0	1000		0	1000	μ F
Duty cycle	$R_T = 2\text{ k}\Omega$			67			67	%
	$R_T = \text{MAX } R_{ext}$			90			90	
T_A Operating free-air temperature	54 Family		- 55	125		- 55	125	°C
	74 Family		0	70				

3

TTL DEVICES

TYPES SN54121, SN54L121, SN74121 MONOSTABLE MULTIVIBRATORS WITH SCHMITT-TRIGGER INPUTS

electrical characteristics over recommended operating free-air temperature range (unless otherwise noted)

PARAMETER	TEST CONDITIONS†	SN54121 SN74121			SN54L121			UNIT	
		MIN	TYP‡	MAX	MIN	TYP‡	MAX		
V _{T+} Positive-going threshold voltage at A input	V _{CC} = MIN		1.4	2		1.4	2	V	
V _{T-} Negative-going threshold voltage at A input	V _{CC} = MIN	0.8	1.4		0.8	1.4		V	
V _{T+} Positive-going threshold voltage at B input	V _{CC} = MIN		1.55	2		1.55	2	V	
V _{T-} Negative-going threshold voltage at B input	V _{CC} = MIN	0.8	1.35		0.8	1.35		V	
V _{IK} Input clamp voltage	V _{CC} = MIN, I _I = -12 mA			-1.5			-1.5	V	
V _{OH} High-level output voltage	V _{CC} = MIN, I _{OH} = MAX	2.4	3.4		2.4	3.4		V	
V _{OL} Low-level output voltage	V _{CC} = MIN, I _{OL} = MAX		0.2	0.4		0.2	0.4	V	
I _I Input current at maximum input voltage	V _{CC} = MAX, V _I = 5.5 V			1			1	mA	
I _{IH} High-level input current	V _{CC} = MAX, V _I = 2.4 V	A1 or A2		40			20	μA	
		B		80			40		
I _{IL} Low-level input current	V _{CC} = MAX, V _I = 0.4 V	A1 or A2		-1.6			-0.8	mA	
		B		-3.2			-1.6		
I _{OS} Short-circuit output current*	V _{CC} = MAX	54 Family	-20	-55	-10		-27	mA	
		74 Family	-18	-55					
I _{CC} Supply current	V _{CC} = MAX	Quiescent		13	25		7	12	mA
		Triggered		23	40		9	20	

† For conditions shown as MIN or MAX, use the appropriate value specified under recommended operating conditions.

‡ All typical values are at V_{CC} = 5 V, T_A = 25°C.

* Not more than one output should be shorted at a time.

3

TTL DEVICES

switching characteristics, V_{CC} = 5 V, T_A = 25°C

PARAMETER	TEST CONDITIONS	'121			'L121			UNIT	
		MIN	TYP	MAX	MIN	TYP	MAX		
t _{PLH} Propagation delay time, low-to-high-level Q output from either A input	C _L = 15 pF, R _L = 400 Ω for '121, R _L = 800 Ω for 'L121, See Note 2		45	70			140	ns	
t _{PLH} Propagation delay time, low-to-high-level Q output from B input			35	55			110	ns	
t _{PHL} Propagation delay time, high-to-low-level Q output from either A input			50	80			160	ns	
t _{PHL} Propagation delay time, high-to-low-level Q output from B input			40	65			130	ns	
t _{w(out)} Pulse width obtained using internal timing resistor		C _{ext} = 80 pF, R _{int} to V _{CC}	70	110	150	70	225	260	ns
t _{w(out)} Pulse width obtained with zero timing capacitance		C _{ext} = 0, R _{int} to V _{CC}		30	50		35	70	ns
t _{w(out)} Pulse width obtained using external timing resistor		C _{ext} = 100 pF, R _T = 10 kΩ	600	700	800	600	700	850	ns
	C _{ext} = 1 μF, R _T = 10 kΩ	6	7	8	6	7	8	ms	

NOTE 2: See General Information Section for load circuits and voltage waveforms.

TYPES SN54121, SN54L121, SN74121 MONOSTABLE MULTIVIBRATORS WITH SCHMITT-TRIGGER INPUTS

TYPICAL CHARACTERISTICS[§]

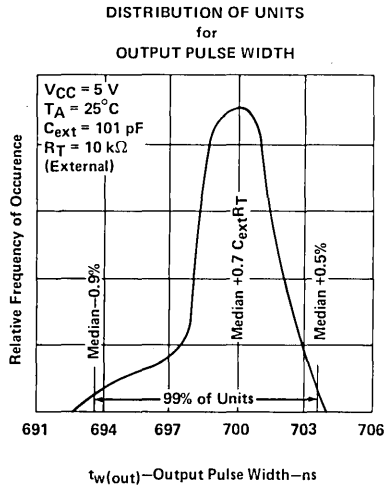

FIGURE 1

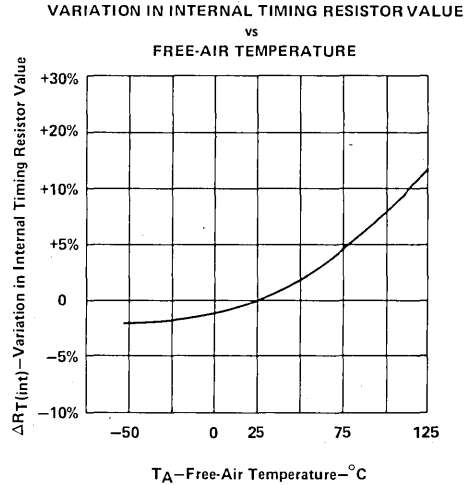

FIGURE 2

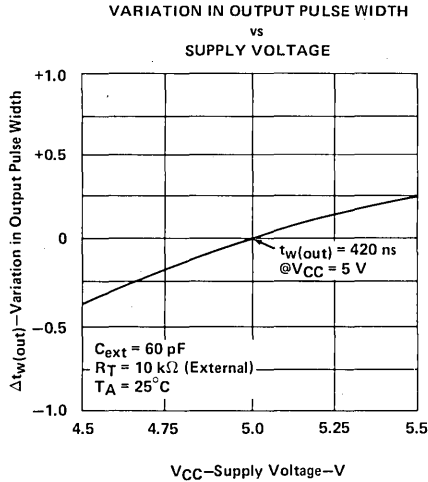

FIGURE 3

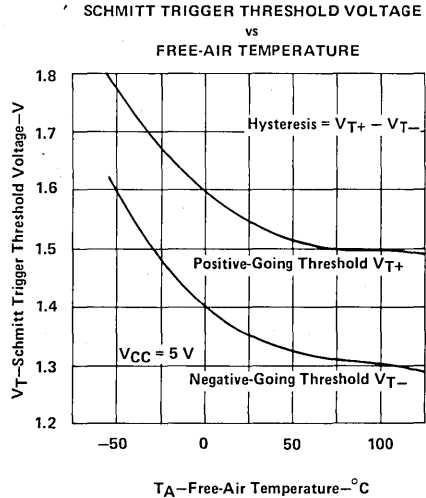

FIGURE 4

[§]Data for temperatures below 0°C and above 70°C are applicable for SN54121 and SN54L121.



TTL DEVICES

TYPES SN54121, SN54L121, SN74121 MONOSTABLE MULTIVIBRATORS WITH SCHMITT-TRIGGER INPUTS

TYPICAL CHARACTERISTICS[§] (continued)

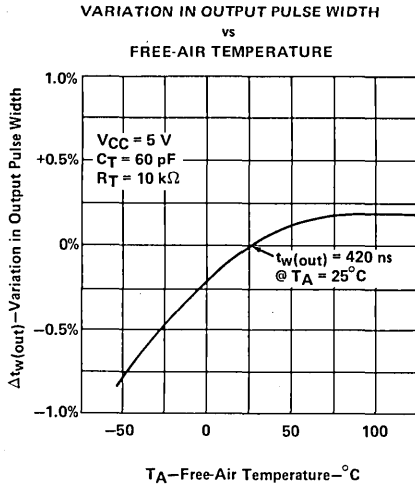

FIGURE 5

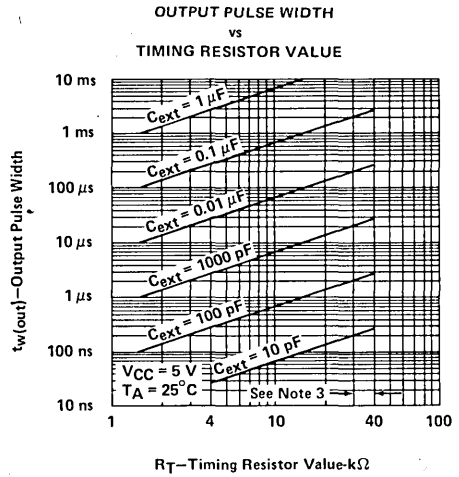

FIGURE 6

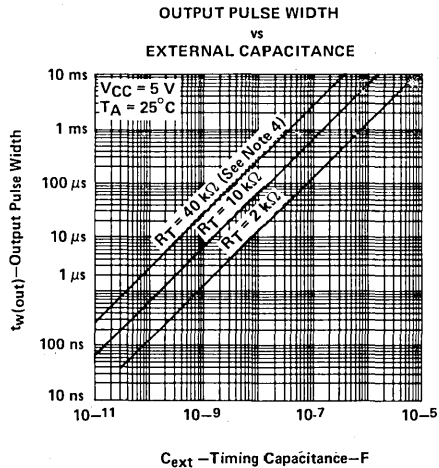

FIGURE 7

NOTE 3: These values of resistance exceed the maximum recommended use over the full temperature range of the SN54LS121.
§Data for temperatures below 0°C and above 70°C are applicable for SN54121 and SN54L121.

3

TTL DEVICES

SN54122, SN54123, SN54130, SN54L122, SN54L123, SN54LS122, SN54LS123, SN74122, SN74123, SN74130, SN74LS122, SN74LS123

RETRIGGERABLE MONOSTABLE MULTIVIBRATORS

REVISED DECEMBER 1983

- D-C Triggered from Active-High or Active-Low Gated Logic Inputs
- Retriggerable for Very Long Output Pulses, Up to 100% Duty Cycle
- Overriding Clear Terminates Output Pulse
- '122, 'L122, 'LS122 Have Internal Timing Resistors

description

These d-c triggered multivibrators feature output pulse width control by three methods. The basic pulse time is programmed by selection of external resistance and capacitance values (see typical application data). The '122, 'L122, and 'LS122 have internal timing resistors that allow the circuits to be used with only an external capacitor, if so desired. Once triggered, the basic pulse width may be extended by retriggering the gated low-level-active (A) or high-level-active (B) inputs, or be reduced by use of the overriding clear. Figure 1 illustrates pulse control by retriggering and early clear.

The 'LS122 and 'LS123 are provided enough Schmitt hysteresis to ensure jitter-free triggering from the B input with transition rates as slow as 0.1 millivolt per nanosecond.

The R_{int} is nominally 10 k ohms for '122, 'LS122, and is nominally 20 k ohms for 'L122.

SN54123, SN54130, SN54LS123 ... J OR W PACKAGE
 SN54L123 ... J PACKAGE
 SN74123, SN74130 ... J OR N PACKAGE
 SN74LS123 ... D, J OR N PACKAGE
 (TOP VIEW) (SEE NOTES 1 THRU 4)

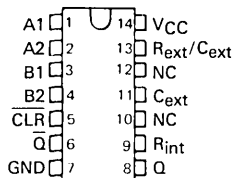

SN54LS122 ... FK PACKAGE
 SN74LS122 ... FN PACKAGE
 (TOP VIEW) (SEE NOTES 1 THRU 4)

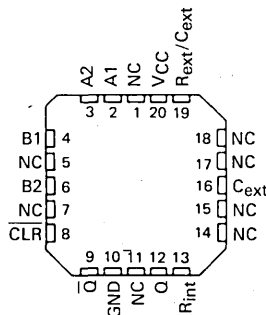

SN54LS123 ... FK PACKAGE
 SN74LS123 ... FN PACKAGE
 (TOP VIEW) (SEE NOTES 1 THRU 4)

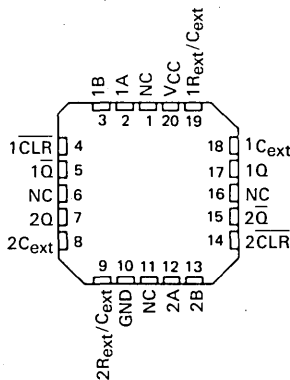

SN54122, SN54LS122 ... J OR W PACKAGE
 SN54L122 ... J PACKAGE
 SN74122 ... J OR N PACKAGE
 SN74LS122 ... D, J OR N PACKAGE
 (TOP VIEW) (SEE NOTES 1 THRU 4)

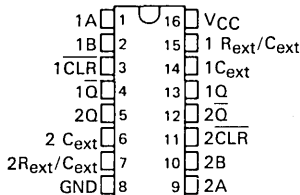

- NOTES:
1. An external timing capacitor may be connected between C_{ext} and R_{ext}/C_{ext} (positive).
 2. To use the internal timing resistor of '122, 'L122, or 'LS122, connect R_{int} to V_{CC} .
 3. For improved pulse width accuracy and repeatability, connect an external resistor between R_{ext}/C_{ext} and V_{CC} with R_{int} open-circuited.
 4. To obtain variable pulse widths, connect an external variable resistance between R_{int} or R_{ext}/C_{ext} and V_{CC} .

3

TTL DEVICES

PRODUCTION DATA
 This document contains information current as of publication date. Products conform to specifications per the terms of Texas Instruments standard warranty. Production processing does not necessarily include testing of all parameters.



POST OFFICE BOX 225012 • DALLAS, TEXAS 75265

SN54122, SN54123, SN54130, SN54L122, SN54L123, SN54LS122, SN54LS123,
 SN74122, SN74123, SN74130, SN74LS122, SN74LS123
 RETRIGGERABLE MONOSTABLE MULTIVIBRATORS

description (continued)

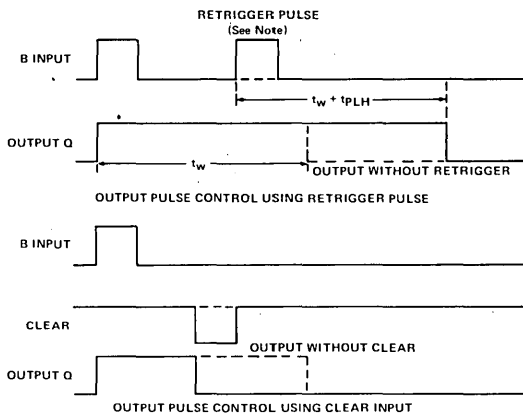

NOTE: Retrigger pulses starting before $0.22 C_{ext}$ (in picofrads) nanoseconds after the initial trigger pulse will be ignored and the output pulse will remain unchanged.

FIGURE 1—TYPICAL INPUT/OUTPUT PULSES

'122, 'L122, 'LS122
 FUNCTION TABLE

CLEAR	INPUTS				OUTPUTS	
	A1	A2	B1	B2	Q	\bar{Q}
L	X	X	X	X	L	H
X	H	H	X	X	L†	H†
X	X	X	L	X	L†	H†
X	X	X	X	L	L†	H†
H	L	X	†	H		
H	L	X	H	†		
H	X	L	†	H		
H	X	L	H	†		
H	H	H	†	H		
H	†	†	H	H		
H	†	H	H	H		
†	L	X	H	H		
†	X	L	H	H		

'123, '130, 'L123, 'LS123
 FUNCTION TABLE

CLEAR	INPUTS		OUTPUTS	
	A	B	Q	\bar{Q}
L	X	X	L	H
X	H	X	L†	H†
X	X	L	L†	H†
H	L	†		
H	†	H		
†	L	H		

See explanation of function tables on page

† These lines of the functional tables assume that the indicated steady-state conditions at the A and B inputs have been set up long enough to complete any pulse started before the set up.

3

TTL DEVICES

SN54122, SN54123, SN54130, SN54L122, SN54L123, SN54LS122, SN54LS123,
 SN74122, SN74123, SN74130, SN74LS122, SN74LS123
 RETRIGGERABLE MONOSTABLE MULTIVIBRATORS

schematics of inputs and outputs

'122, '123, '130, 'L122, 'L123 CIRCUITS

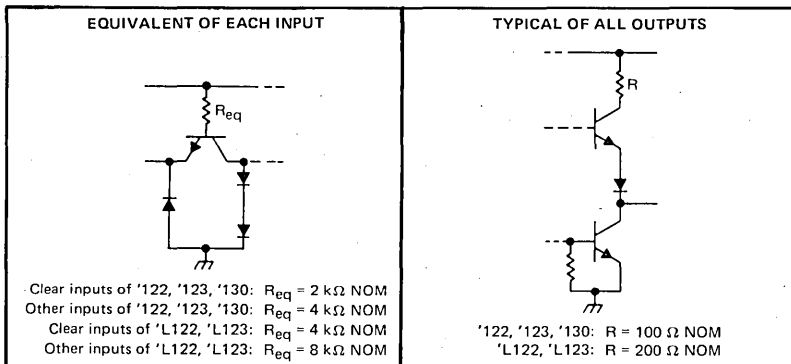

'LS122, 'LS123 CIRCUITS

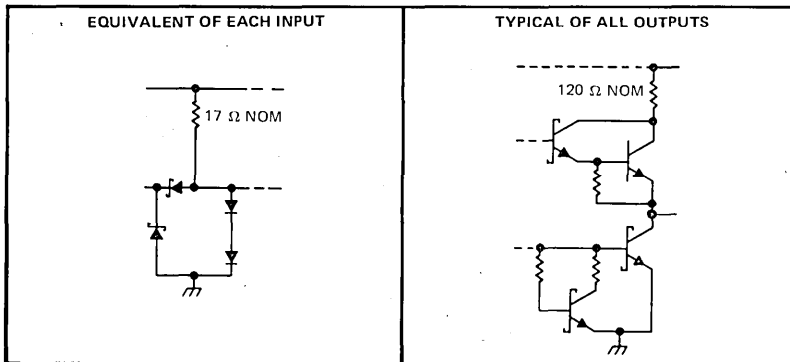

3

TTL DEVICES

TYPES SN54122, SN54123, SN54130, SN74122, SN74123, SN74130 RETRIGGERABLE MONOSTABLE MULTIVIBRATORS

recommended operating conditions

	SN54*			SN74*			UNIT
	MIN	NOM	MAX	MIN	NOM	MAX	
Supply voltage, V_{CC}	4.5	5	5.5	4.75	5	5.25	V
High-level output current, I_{OH}			-800			-800	μ A
Low-level output current, I_{OL}			16			16	mA
Pulse width, t_w	40			40			ns
External timing resistance, R_{ext}	5	25		5	50		k Ω
External capacitance, C_{ext}	No restriction			No restriction			
Wiring capacitance at R_{ext}/C_{ext} terminal	50			50			pF
Operating free-air temperature, T_A	-55	125		0	70		$^{\circ}$ C

electrical characteristics over recommended free-air operating temperature range (unless otherwise noted)

PARAMETER		TEST CONDITIONS†	'122			'123, '130			UNIT
			MIN	TYP‡	MAX	MIN	TYP‡	MAX	
V_{IH}	High-level input voltage		2			2			V
V_{IL}	Low-level input voltage				0.8			0.8	V
V_{IK}	Input clamp voltage	$V_{CC} = \text{MIN}, I_I = -12 \text{ mA}$			-1.5			-1.5	V
V_{OH}	High-level output voltage	$V_{CC} = \text{MIN}, I_{OH} = -800 \mu\text{A}$, See Note 1	2.4	3.4		2.4	3.4		V
V_{OL}	Low-level output voltage	$V_{CC} = \text{MIN}, I_{OL} = 16 \text{ mA}$, See Note 1		0.2	0.4		0.2	0.4	V
I_I	Input current at maximum input voltage	$V_{CC} = \text{MAX}, V_I = 5.5 \text{ V}$			1			1	mA
I_{IH}	High-level input current	Data inputs			40			40	μ A
		Clear input	$V_{CC} = \text{MAX}, V_I = 2.4 \text{ V}$		80		80		
I_{IL}	Low-level input current	Data inputs			-1.6			-1.6	mA
		Clear input	$V_{CC} = \text{MAX}, V_I = 0.4 \text{ V}$		-3.2		-3.2		
I_{OS}	Short-circuit output current*	$V_{CC} = \text{MAX}$, See Note 5	-10		-40	-10		-40	mA
I_{CC}	Supply current (quiescent or triggered)	$V_{CC} = \text{MAX}$, See Notes 6 and 7		23	36		46	66	mA

† For conditions shown as MIN or MAX, use the value specified under recommended operating conditions.

‡ All typical values are at $V_{CC} = 5 \text{ V}, T_A = 25^{\circ}\text{C}$.

* Not more than one output should be shorted at a time.

NOTES: 5. Ground C_{ext} to measure V_{OH} at Q, V_{OL} at \bar{Q} , or I_{OS} at Q. C_{ext} is open to measure V_{OH} at \bar{Q} , V_{OL} at Q, or I_{OS} at \bar{Q} .

6. Quiescent I_{CC} is measured (after clearing) with 2.4 V applied to all clear and A inputs, B inputs grounded, all outputs open, $C_{ext} = 0.02 \mu\text{F}$, and $R_{ext} = 25 \text{ k}\Omega$. R_{int} of '122 is open.

7. I_{CC} is measured in the triggered state with 2.4 V applied to all clear and B inputs, A inputs grounded, all outputs open, $C_{ext} = 0.02 \mu\text{F}$, and $R_{ext} = 25 \text{ k}\Omega$. R_{int} of '122 is open.

switching characteristics, $V_{CC} = 5 \text{ V}, T_A = 25^{\circ}\text{C}$, see note 8

PARAMETER †	FROM (INPUT)	TO (OUTPUT)	TEST CONDITIONS	'122, '130			'123			UNIT
				MIN	TYP	MAX	MIN	TYP	MAX	
t_{PLH}	A	Q	$C_{ext} = 0, R_{ext} = 5 \text{ k}\Omega,$ $C_L = 15 \text{ pF}, R_L = 400 \Omega$	22	33		22	33	ns	
	B	Q		19	28		19	28		
t_{PHL}	A	\bar{Q}		30	40		30	40	ns	
	B	\bar{Q}		27	36		27	36		
t_{PHL}	Clear	Q		18	27		18	27	ns	
t_{PLH}		\bar{Q}		30	40		30	40		
t_{wQ} (min)	A or B	Q		45	65		45	65	ns	
t_{wQ}	A or B	Q		3.08	3.42	3.76	2.76	3.03	3.37	μ s

† t_{PLH} = propagation delay time, low-to-high-level output

t_{PHL} = propagation delay time, high-to-low-level output

t_{wQ} = width of pulse at output Q

NOTE 8: See General Information Section for load circuits and voltage waveforms.

TYPES SN54L122, SN54L123, RETRIGGERABLE MONOSTABLE MULTIVIBRATORS

recommended operating conditions

		SN54L*			UNIT
		MIN	NOM	MAX	
V _{CC}	Supply voltage	4.5	5	5.5	V
I _{OH}	High-level output current			-0.4	mA
I _{OL}	Low-level output current			8	mA
t _w	Pulse width	50			ns
R _{ext}	External timing resistance	5		25	kΩ
C _{ext}	External capacitance	No restriction			
	Wiring capacitance at R _{ext} /C _{ext} terminal			50	pF
T _A	Operating free-air temperature	-55		125	°C

electrical characteristics over recommended free-air operating temperature range (unless otherwise noted)

PARAMETER	TEST CONDITIONS†	'L122			'L123			UNIT	
		MIN	TYP‡	MAX	MIN	TYP‡	MAX		
V _{IH}	High-level input voltage	2			2			V	
V _{IL}	Low-level input voltage			0.8			0.8	V	
V _{IK}	Input clamp voltage	V _{CC} = MIN, I _I = -12 mA			-1.5			V	
V _{OH}	High-level output voltage	V _{CC} = MIN, I _{OH} = -0.4 mA, See Note 1			2.4	3.4	2.4	3.4	V
V _{OL}	Low-level output voltage	V _{CC} = MIN, I _{OL} = 8 mA, See Note 1			0.2	0.4	0.2	0.4	V
I _I	Input current at maximum input voltage	V _{CC} = MAX, V _I = 5.5 V			1			1	mA
I _{IH}	High-level input current	Data inputs	V _{CC} = MAX, V _I = 2.4 V			20			μA
		Clear input				40			
I _{IL}	Low-level input current	Data inputs	V _{CC} = MAX, V _I = 0.4 V			-0.8			mA
		Clear input				-1.6			
I _{OS}	Short-circuit output current*	V _{CC} = MAX, See Note 9			-5	-20	-5	-20	mA
I _{CC}	Supply current (quiescent or triggered)	V _{CC} = MAX, See Notes 10 and 11			11	14	23	33	mA

† For conditions shown as MIN or MAX, use the value specified under recommended operating conditions.

‡ All typical values are at V_{CC} = 5 V, T_A = 25°C.

* Not more than one output should be shorted at a time.

NOTES: 9. Ground C_{ext} to measure V_{OH} at Q, V_{OL} at \bar{Q} , or I_{OS} at Q. C_{ext} is open to measure V_{OH} at \bar{Q} , V_{OL} at Q, or I_{OS} at \bar{Q} .

10. Quiescent I_{CC} is measured (after clearing) with 2.4 V applied to all clear and A inputs, B inputs grounded, all outputs open, C_{ext} = 0.02 μF, and R_{ext} = 25 kΩ. R_{int} of 'L122 is open.

11. I_{CC} is measured in the triggered state with 2.4 V applied to all clear and B inputs, A inputs grounded, all outputs open, C_{ext} = 0.02 μF, and R_{ext} = 25 kΩ. R_{int} of 'L122 is open.

switching characteristics, V_{CC} = 5 V, T_A = 25°C, see note 8

PARAMETER‡	FROM (INPUT)	TO (OUTPUT)	TEST CONDITIONS	'L122			'L123			UNIT
				MIN	TYP	MAX	MIN	TYP	MAX	
t _{PLH}	A	Q	C _{ext} = 0, R _{ext} = 5 kΩ, C _L = 15 pF, R _L = 800 Ω	44	66		44	66		ns
	B			38	56		38	56		
t _{PHL}	A	\bar{Q}		60	80		60	80		ns
	B			54	72		54	72		
t _{PHL}	Clear	Q		36	54		36	54		ns
t _{PLH}		\bar{Q}		60	80		60	80		
t _{wQ} (min)	A or B	Q		90	135		90	135		ns
t _{wQ}	A or B	Q		C _{ext} = 400 pF, C _L = 15 pF, R _{ext} = 10 kΩ, R _L = 800 Ω	1.7	1.9	2.1	1.3	2.1	

‡ t_{PLH} ≡ propagation delay time, low-to-high-level output

t_{PHL} ≡ propagation delay time, high-to-low-level output

t_{wQ} ≡ width of pulse at output Q

NOTE 8: See General Information Section for load circuits and voltage waveforms.

TYPES SN54LS122, SN54LS123, SN74LS122, SN74LS123 RETRIGGERABLE MONOSTABLE MULTIVIBRATORS

recommended operating conditions

	SN54LS'			SN74LS'			UNIT
	MIN	NOM	MAX	MIN	NOM	MAX	
Supply voltage, V_{CC}	4.5	5	5.5	4.75	5	5.25	V
High-level output current, I_{OH}				-400			μ A
Low-level output current, I_{OL}				8			mA
Pulse width, t_W	40			40			ns
External timing resistance, R_{ext}	5			180			$k\Omega$
External capacitance, C_{ext}	No restriction			No restriction			
Wiring capacitance at R_{ext}/C_{ext} terminal	50			50			pF
Operating free-air temperature, T_A	-55		125	0		70	$^{\circ}$ C

electrical characteristics over recommended operating free-air temperature range (unless otherwise noted)

PARAMETER	TEST CONDITIONS†	SN54LS'			SN74LS'			UNIT		
		MIN	TYP‡	MAX	MIN	TYP‡	MAX			
V_{IH} High-level input voltage		2			2			V		
V_{IL} Low-level input voltage					0.7			V		
V_{IK} Input clamp voltage	$V_{CC} = \text{MIN}, I_I = -18 \text{ mA}$				-1.5			V		
V_{OH} High-level output voltage	$V_{CC} = \text{MIN}, V_{IH} = 2 \text{ V}, V_{IL} = V_{ILmax}, I_{OH} = -400 \mu\text{A}$	2.5	3.5		2.7	3.5		V		
V_{OL} Low-level output voltage	$V_{CC} = \text{MIN}, V_{IH} = 2 \text{ V}, V_{IL} = V_{ILmax}$			$I_{OL} = 4 \text{ mA}$	0.25	0.4	$I_{OL} = 8 \text{ mA}$	V		
I_I Input current at maximum input voltage	$V_{CC} = \text{MAX}, V_I = 7 \text{ V}$				0.1		0.1	mA		
I_{IH} High-level input current	$V_{CC} = \text{MAX}, V_I = 2.7 \text{ V}$				20		20	μ A		
I_{IL} Low-level input current	$V_{CC} = \text{MAX}, V_I = 0.4 \text{ V}$				-0.4		-0.4	mA		
I_{OS} Short-circuit output current*	$V_{CC} = \text{MAX}$	-20		-100	-20		-100	mA		
I_{CC} Supply current (quiescent or triggered)	$V_{CC} = \text{MAX},$ See Note 13			'LS122	6	11	'LS123	6	11	mA
					12	20		12	20	mA

† For conditions shown as MIN or MAX, use the appropriate value specified under recommended operating conditions.

‡ All typical values are at $V_{CC} = 5 \text{ V}, T_A = 25^{\circ}\text{C}$.

* Not more than one output should be shorted at a time and duration of the short-circuit should not exceed one second.

NOTES: 12. To measure V_{OH} at Q, V_{OL} at \bar{Q} , or I_{OS} at Q, ground R_{ext}/C_{ext} , apply 2 V to B and clear, and pulse A from 2 V to 0 V.

13. With all outputs open and 4.5 V applied to all data and clear inputs, I_{CC} is measured after a momentary ground, then 4.5 V, is applied to clock.

switching characteristics, $V_{CC} = 5 \text{ V}, T_A = 25^{\circ}\text{C}$ (see note 8)

PARAMETER¶	FROM (INPUT)	TO (OUTPUT)	TEST CONDITIONS	MIN	TYP	MAX	UNIT	
t_{PLH}	A	Q	$C_{ext} = 0, R_{ext} = 5 \text{ k}\Omega, C_L = 15 \text{ pF}, R_L = 2 \text{ k}\Omega$	23	33		ns	
	B	Q		23	44			
t_{PHL}	A	\bar{Q}		32	45		ns	
	B	\bar{Q}		34	56			
t_{PHL}	Clear	Q		20	27		ns	
t_{PLH}	Clear	\bar{Q}		28	45			
$t_{wQ}(\text{min})$	A or B	Q			116	200		ns
t_{wQ}	A or B	Q		$C_{ext} = 1000 \text{ pF}, C_L = 15 \text{ pF}, R_{ext} = 10 \text{ k}\Omega, R_L = 2 \text{ k}\Omega$	4	4.5	5	μ s

¶ t_{PLH} = propagation delay time, low-to-high-level output

t_{PHL} = propagation delay time, high-to-low-level output

t_{wQ} = width of pulse at output Q

NOTE 8: See General Information Section for load circuits and voltage waveforms.

TTL DEVICES

TYPES SN54122, SN54123, SN54130, SN54L122, SN54L123, SN74122, SN74123, SN74130 RETRIGGERABLE MONOSTABLE MULTIVIBRATORS

TYPICAL APPLICATION DATA FOR '122, '123, '130, 'L122, 'L123

For pulse widths when $C_{ext} \leq 1000$ pF, See Figures 4 and 5.

The output pulse is primarily a function of the external capacitor and resistor. For $C_{ext} > 1000$ pF, the output pulse width (t_w) is defined as:

$$t_w = K \cdot R_T \cdot C_{ext} \left(1 + \frac{0.7}{R_T} \right)$$

where

K is 0.32 for '122, 0.28 for '123, '130, 0.37 for 'L122, 0.33 for 'L123

R_T is in $k\Omega$ (internal or external timing resistance.)

C_{ext} is in pF

t_w is in nanoseconds

To prevent reverse voltage across C_{ext} , it is recommended that the method shown in Figure 2 be employed when using electrolytic capacitors and in applications utilizing the clear function. In all applications using the diode, the pulse width is:

$$t_w = K_D \cdot R_T \cdot C_{ext} \left(1 + \frac{0.7}{R_T} \right)$$

K_D is 0.28 for '122, 0.25 for '123, '130, 0.33 for 'L122, 0.29 for 'L123

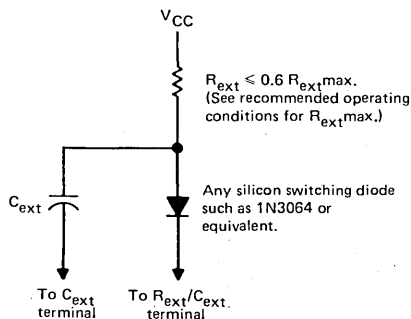

TIMING COMPONENT CONNECTIONS WHEN $C_{ext} > 1000$ pF AND CLEAR IS USED

FIGURE 2

Applications requiring more precise pulse widths (up to 28 seconds) and not requiring the clear feature can best be satisfied with the '121 or 'L121.

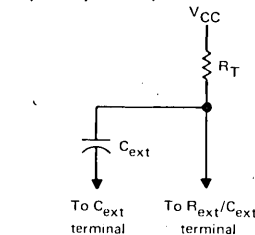

TIMING COMPONENT CONNECTIONS
FIGURE 3

'122, '123, '130
TYPICAL OUTPUT PULSE WIDTH
vs
EXTERNAL TIMING CAPACITANCE

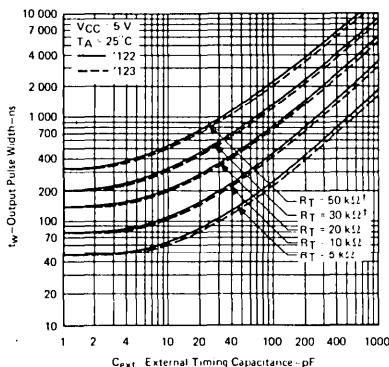

FIGURE 4

'L122
TYPICAL OUTPUT PULSE WIDTH
vs
EXTERNAL TIMING CAPACITANCE

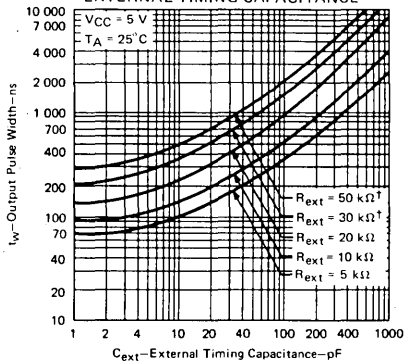

FIGURE 5

† These values of resistance exceed the maximum recommended for use over the full temperature range of the SN54' and SN54L' circuits.

TYPES SN54LS122, SN54LS123, SN74LS122, SN74LS123 RETRIGGERABLE MONOSTABLE MULTIVIBRATORS

TYPICAL APPLICATION DATA FOR 'LS122, 'LS123

The basic output pulse width is essentially determined by the values of external capacitance and timing resistance. For pulse widths when $C_{ext} \leq 1000$ pF, use Figure 7, or may be defined as:

$$t_w \approx K \cdot R_T \cdot C_{ext}$$

When $C_{ext} \geq 1$ μ F, the output pulse width is defined as:

$$t_w \approx 0.33 \cdot R_T \cdot C_{ext}$$

Where

K is multiplier factor, see Figure 8

R_T is in K ohms (internal or external timing resistance)

C_{ext} is in pF

t_w is in nanoseconds

For maximum noise immunity, system ground should be applied to the C_{ext} node, even though the C_{ext} node is already tied to the ground lead internally. Due to the timing scheme used by the 'LS122 and 'LS123, a switching diode is not required to prevent reverse biasing when using electrolytic capacitors.

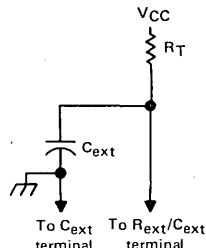

TIMING COMPONENT CONNECTIONS
FIGURE 6

'LS122, 'LS123 TYPICAL OUTPUT PULSE WIDTH vs EXTERNAL TIMING CAPACITANCE

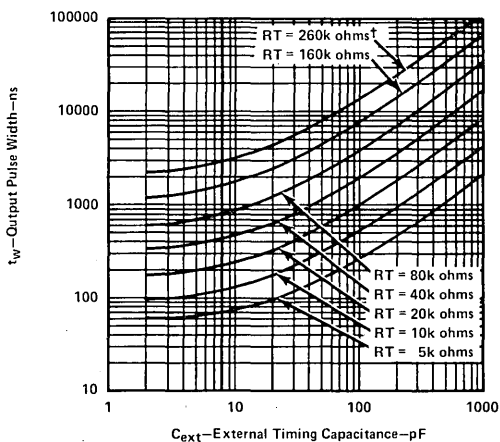

[†]This value of resistance exceeds the maximum recommended for use over the full temperature range of the SN54LS circuits.

FIGURE 7

TYPES SN54LS122, SN54LS123, SN74LS122, SN74LS123 RETRIGGERABLE MONOSTABLE MULTIVIBRATORS

TYPICAL APPLICATION DATA FOR 'LS122, 'LS123†

MULTIPLIER FACTOR
vs
EXTERNAL CAPACITOR

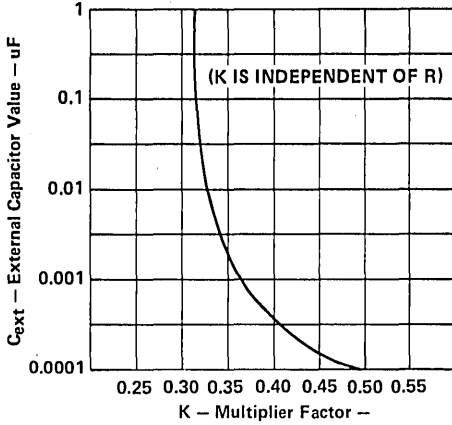

FIGURE 8

DISTRIBUTION OF UNITS
vs
OUTPUT PULSE WIDTH

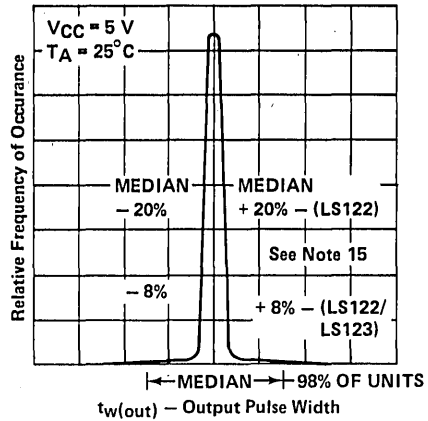

FIGURE 9

VARIATION IN OUTPUT PULSE WIDTH
vs
SUPPLY VOLTAGE

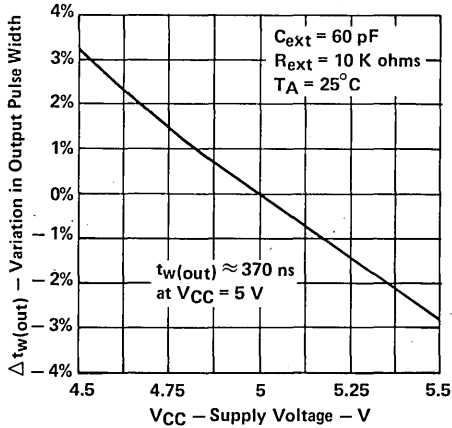

FIGURE 10

VARIATION IN OUTPUT PULSE WIDTH
vs
FREE-AIR TEMPERATURE

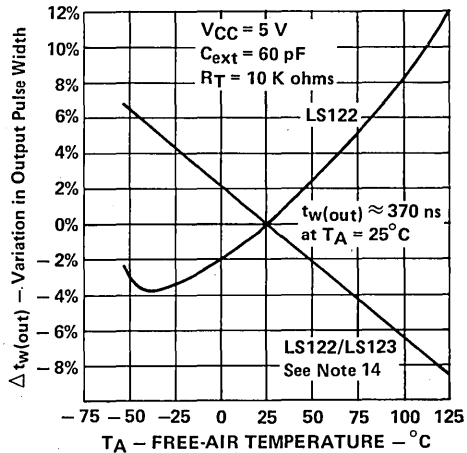

FIGURE 11

NOTE 14: For the 'LS122, the internal timing resistor, R_{int} was used. For the 'LS122/123, an external timing resistor was used for R_T .
†Data for temperatures below $0^\circ C$ and above $70^\circ C$ and for supply voltages below 4.75 V and above 5.25 V are applicable for SN54LS122 and SN54LS123 only.

TYPES SN54S124, SN74S124 DUAL VOLTAGE-CONTROLLED OSCILLATORS

MARCH 1974 — REVISED DECEMBER 1983

- Two Independent VCO's in a 16-Pin Package
- Output Frequency Set by Single External Component:
 - Crystal for High-Stability Fixed-Frequency Operation
 - Capacitor for Fixed- or Variable-Frequency Operation
- Separate Supply Voltage Pins for Isolation of Frequency Control Inputs and Oscillators from Output Circuitry
- Highly Stable Operation over Specified Temperature and/or Supply Voltage Ranges
- Typical f_{max} 85 MHz
Typical Power Dissipation 525 mW
- Frequency Spectrum ... 1 Hz to 60 MHz

description

The 'S124 features two independent voltage-controlled oscillators (VCO) in a single monolithic chip. The output frequency of each VCO is established by a single external component, either a capacitor or a crystal, in combination with two voltage-sensitive inputs, one for frequency range and one for frequency control. These inputs can be used to vary the output frequency as shown under typical characteristics. These highly stable oscillators can be set to operate at any frequency typically between 0.12 hertz and 85 megahertz. Under the conditions used in Figure 3, the output frequency can be approximated as follows:

$$f_o = \frac{5 \times 10^{-4}}{CX}$$

where: f_o = output frequency in hertz

CX = external capacitance in farads.

logic

While the enable input is low, the output is enabled.
While the enable input is high, the output is high.

These devices can operate from a single 5-volt supply. However, one set of supply-voltage and ground pins (V_{CC} and GND) is provided for the enable, synchronization-gating, and output sections, and a separate set ($\ominus V_{CC}$ and $\ominus GND$) is provided for the oscillator and associated frequency-control circuits so that effective isolation can be accomplished in the system.

The enable input of these devices starts or stops the output pulses when it is low or high, respectively. The internal oscillator of the 'S124 is started and stopped by the enable input. The enable input is one standard load; it and the buffered output operate at standard Schottky-clamped TTL levels.

The pulse synchronization-gating section ensures that the first output pulse is neither clipped nor extended. Duty cycle of the square-wave output is fixed at approximately 50 percent.

The SN54S124 is characterized for operation over the full military temperature range of -55°C to 125°C ; the SN74S124 is characterized for operation from 0°C to 70°C .

SN54S124 ... J OR W PACKAGE
SN74S124 ... D, J OR N PACKAGE
(TOP VIEW)

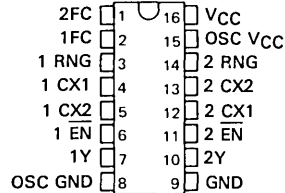

SN54S124 ... FK PACKAGE
SN74S124 ... FN PACKAGE
(TOP VIEW)

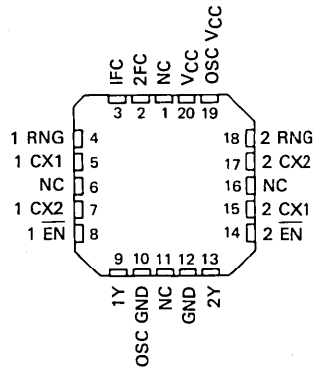

NC - No internal connection

PRODUCTION DATA
This document contains information current as of publication date. Products conform to specifications per the terms of Texas Instruments standard warranty. Production processing does not necessarily include testing of all parameters.

**TEXAS
INSTRUMENTS**

POST OFFICE BOX 225012 • DALLAS, TEXAS 75265

3-487

TYPES SN54S124, SN74S124 DUAL VOLTAGE-CONTROLLED OSCILLATORS

schematics of inputs and outputs

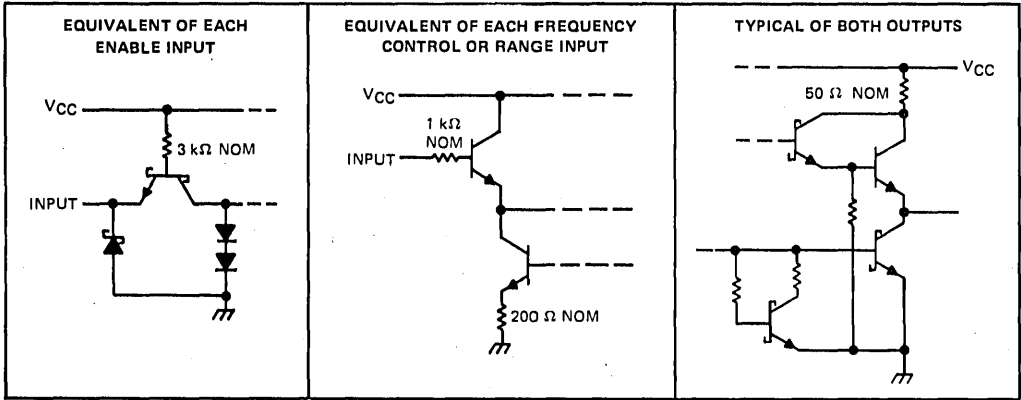

absolute maximum ratings over operating free-air temperature range (unless otherwise noted)

Supply voltage, V_{CC} (See Notes 1 and 2)	7V
Input voltage	5.5 V
Operating free-air temperature range: SN54S124	-55°C to 125°C
SN74S124	0°C to 70°C
Storage temperature range	-65°C to 150°C

- NOTES: 1. Voltage values are with respect to the appropriate ground terminal.
 2. Throughout this data sheet, the symbol V_{CC} is used for the voltage applied to both the V_{CC} and $\ominus V_{CC}$ terminals, unless otherwise noted.

3

TTL DEVICES

TYPES SN54S124, SN74S124 DUAL VOLTAGE-CONTROLLED OSCILLATORS

recommended operating conditions

	SN54S124			SN74S124			UNIT
	*MIN	NOM	MAX	MIN	NOM	MAX	
Supply voltage, V_{CC} (see Note 1)	4.5	5	5.5	4.75	5	5.25	V
Input voltage at frequency control or range input, $V_{I(freq)}$ or $V_{I(rng)}$	1		5	1		5	V
High-level output current, I_{OH}			-1			-1	mA
Low-level output current, I_{OL}			20			20	mA
Output frequency (enabled), f_o	1			1			Hz
			60			60	MHz
Operating free-air temperature, T_A	-55		125	0		70	°C

electrical characteristics over recommended operating free-air temperature range (unless otherwise noted)

PARAMETER		TEST CONDITIONS†	MIN	TYP‡	MAX	UNIT	
V_{IH}	High-level input voltage at enable		2			V	
V_{IL}	Low-level input voltage at enable				0.8	V	
V_{IK}	Input clamp voltage at enable	$V_{CC} = \text{MIN}, I_I = -18 \text{ mA}$			-1.2	V	
V_{OH}	High-level output voltage	$V_{CC} = \text{MIN}, V_{IH} = 2 \text{ V}, I_{OH} = -1 \text{ mA}$	SN54S'	2.5	3.4	V	
			SN74S'	2.7	3.4		
V_{OL}	Low-level output voltage	$V_{CC} = \text{MIN}, V_{IL} = 0.8 \text{ V}, I_{OL} = 20 \text{ mA}$			0.5	V	
I_I	Input current	Freq control or range	$V_{CC} = \text{MAX}$	$V_I = 5 \text{ V}$	10	50	μA
				$V_I = 1 \text{ V}$	1	15	
I_I	Input current at maximum input voltage	Enable	$V_{CC} = \text{MAX}, V_I = 5.5 \text{ V}$			1	mA
I_{IH}	High-level input current	Enable	$V_{CC} = \text{MAX}, V_I = 2.7 \text{ V}$			50	μA
I_{IL}	Low-level input current	Enable	$V_{CC} = \text{MAX}, V_I = 0.5 \text{ V}$			-2	mA
I_{OS}	Short-circuit output current‡		$V_{CC} = \text{MAX}$	-40		-100	mA
I_{CC}	Supply current, total into V_{CC} and $\ominus V_{CC}$		$V_{CC} = \text{MAX}, \text{ See Note 3}$	105		150	mA
			$V_{CC} = \text{MAX}, T_A = 125^\circ\text{C}, \text{ W package only}$			110	

†For conditions shown as MIN or MAX, use the appropriate value specified under recommended operating conditions.

‡All typical values are at $V_{CC} = 5 \text{ V}, T_A = 25^\circ\text{C}$.

§Not more than one output should be shorted at a time and duration of the short-circuit should not exceed one second.

NOTE 3: I_{CC} is measured with the outputs disabled and open.

switching characteristics, $V_{CC} = 5 \text{ V}, R_L = 280 \Omega, C_L = 15 \text{ pF}, T_A = 25^\circ\text{C}$ (see note 4)

PARAMETER		TEST CONDITIONS	MIN	TYP	MAX	UNIT
f_o	Output frequency	$CX = 2 \text{ pF}$	$V_{I(freq)} = 4 \text{ V}, V_{I(rng)} = 1 \text{ V}$	60	85	MHz
			$V_{I(freq)} = 1 \text{ V}, V_{I(rng)} = 5 \text{ V}$	25	40	
	Output duty cycle	$CX = 8.3 \text{ pF}$ to $500 \mu\text{F}$		50%		
t_{PHL}	Propagation delay time, high-to-low-level output from enable	$f_o = 1 \text{ Hz}$ to 20 MHz		1.4		s
		$f_o > 20 \text{ MHz}$		70		ns

NOTE 4: See General Information Section for load circuits and voltage waveforms.

3
TTL DEVICES

TYPES SN54S124, SN74S124 DUAL VOLTAGE-CONTROLLED OSCILLATORS

TYPICAL APPLICATION DATA

free-running oscillator

Free-running oscillators can be implemented for most systems by setting the output frequency of the VCO with either a capacitor or a crystal. If excitation is provided with a capacitor the frequency control and/or range inputs can be used to vary the output frequency.

When the 'S124 is excited with a crystal, low-frequency response (≤ 1 MHz) can be improved if a relatively small capacitor (5 to 15 pF) is paralleled with the crystal. When operated at the fundamental frequency of a crystal, the frequency control input should be high (≈ 5 V) and the range input should be low (grounded) for maximum stability over temperature and supply voltage variations.

phase-locked loops

A basic crystal-controlled phase-locked loop is illustrated in Figure 1. This application can be used for implementation of:

- A highly stable fixed-frequency clock generator.
- A highly stable fixed- or variable-frequency synthesizer.
- A highly efficient "slave-clock" system for synchronizing off-card, remote, or data-interfacing clock systems

With fixed division rates for both M and N, the output frequency (f_o) will be stable at $f_o = \frac{N}{M} f_1$. Obviously, either M or N, or both, could be programmable counters in which case the output frequency (f_o) will be a variable frequency dependent on the instantaneous value of $\frac{N}{M} f_1$.

The crystal-controlled VCO can be operated up to 60 MHz with an accuracy that is dependent on the crystal. At the higher frequencies, response of the phase comparator can become a limiting factor and one of the following approaches may be necessary to extend the operating frequency range.

- Frequencies $\frac{f_1}{M}$ and $\frac{f_1}{N}$ can be divided equally by the same constant (K) also shown in Figure 1. The constant can be any value greater than unity ($K > 1$), and should be selected to yield frequency ranges that can be handled adequately by the phase-comparator and filter. The output frequency (f_o) retains the same relationship as previously explained because now:

$$f_o = \frac{KN}{KM} f_1 = \frac{N}{M} f_1$$

- In another method, the comparison of $\frac{f_1}{M}$ and $\frac{f_1}{N}$ can be performed with either an SN54LS85/SN74LS85 or SN54S85/SN74S85. The resultant $A > B$ and $A < B$ outputs from the 'LS85 or 'S85 permit the detector to be simplified to a charge-pump circuit. See Figure 2.

TYPES SN54S124, SN74S124
DUAL VOLTAGE-CONTROLLED OSCILLATORS

TYPICAL CHARACTERISTICS

BASE OUTPUT FREQUENCY
vs
EXTERNAL CAPACITANCE

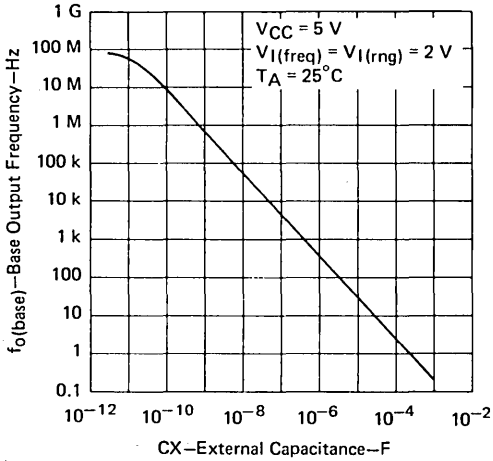

FIGURE 3

NORMALIZED OUTPUT FREQUENCY
vs
INPUT VOLTAGE

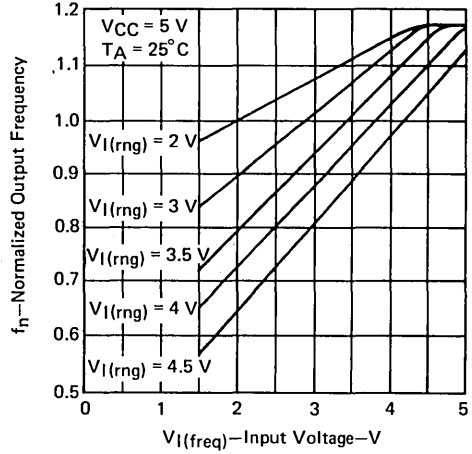

FIGURE 4

NOTE: $f_o = f_n \times f_{o(\text{base})}$

3
TTL DEVICES

TYPES SN54125, SN54126, SN54LS125A, SN54LS126A, SN74125, SN74126, SN74LS125A, SN74LS126A QUADRUPLE BUS BUFFERS WITH 3-STATE OUTPUTS

REVISED DECEMBER 1983

- Quad Bus Buffers
- 3-State Outputs
- Separate Control for Each Channel

description

These bus buffers feature three-state outputs that, when enabled, have the low impedance characteristics of a TTL output with additional drive capability at high logic levels to permit driving heavily loaded bus lines without external pull-up resistors, when disabled, both output transistors are turned off presenting a high-impedance state to the bus so the output will act neither as a significant load nor as a driver. The '125 and 'LS125A outputs are disabled when \bar{G} is high. The '126 and 'LS126A outputs are disabled when G is low.

logic diagram (each gate)

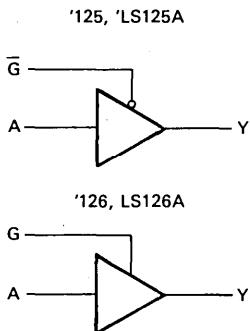

positive logic $Y = A$

absolute maximum ratings over operating free-air temperature range (unless otherwise noted)

Supply voltage, V_{CC} (see Note 1)	7 V
Input voltage: '125, '126	5.5 V
'LS125A, 'LS126A	7 V
Operating free-air temperature range: SN54'	-55° C to 125° C
SN74'	0° C to 70° C
Storage temperature range	-65° C to 150° C

NOTE 1: Voltage values are with respect to network ground terminal.

SN54125, SN54126, SN54LS125A,
SN54LS126A ... J OR W PACKAGE
SN74125, SN74126 ... J OR N PACKAGE
SN74LS125A, SN74LS126A ... D, J OR N PACKAGE
(TOP VIEW)

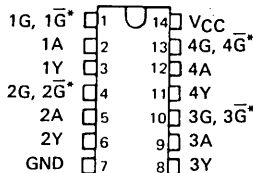

SN54LS125A, SN54LS126A ... FK PACKAGE
SN74LS125A, SN74LS126A ... FN PACKAGE
(TOP VIEW)

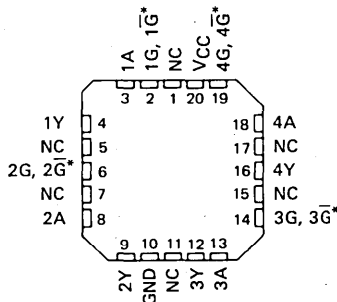

* \bar{G} on '125, 'LS125; G on 126, 'LS126

NC -- No internal connection

3

TTL DEVICES

PRODUCTION DATA
This document contains information current as of publication date. Products conform to specifications per the terms of Texas Instruments standard warranty. Production processing does not necessarily include testing of all parameters.

TEXAS
INSTRUMENTS

POST OFFICE BOX 225012 • DALLAS, TEXAS 75265

3-493

TYPES SN54125, SN54126, SN74125, SN74126
QUADRUPLE BUS BUFFERS WITH 3-STATE OUTPUTS

schematics (each gate)

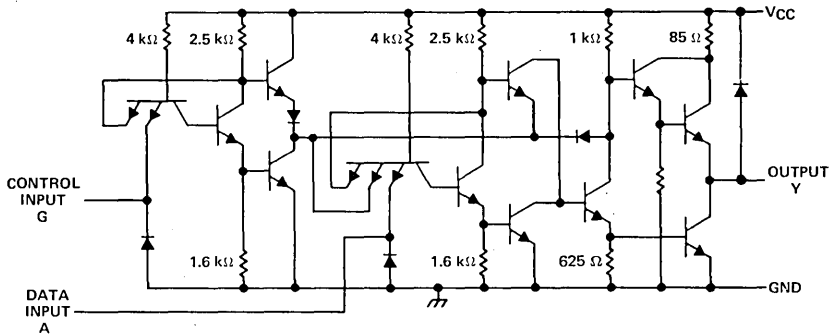

'125 CIRCUITS

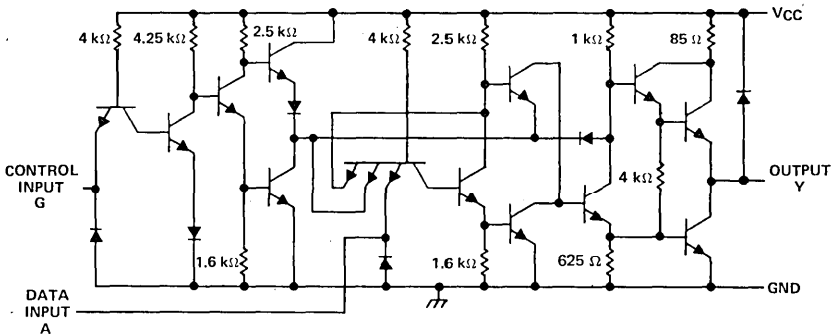

'126 CIRCUITS

Resistor values shown are nominal.

3

TTL DEVICES

TYPES SN54LS125A, SN54LS126A, SN74LS125A, SN74LS126A
 QUADRUPLE BUS BUFFERS WITH 3-STATE OUTPUTS

schematics (each gate)

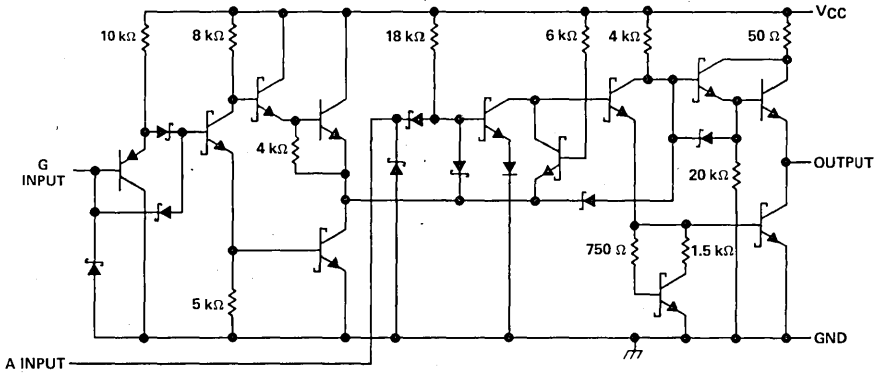

'LS125A CIRCUITS

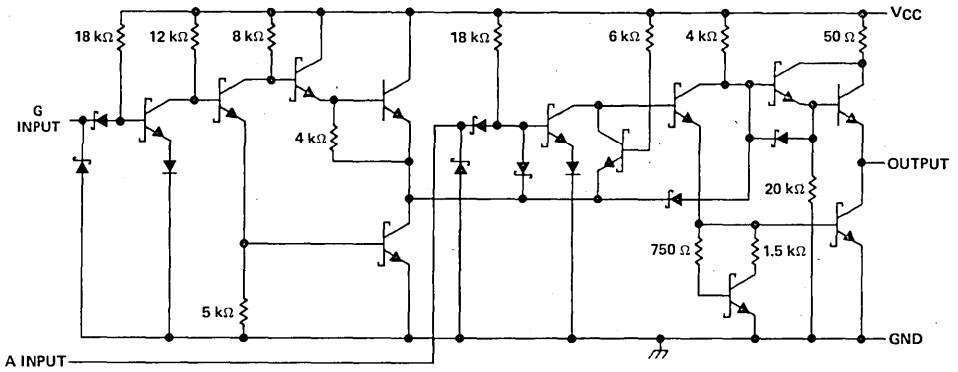

'LS126A CIRCUITS

Resistor values shown are nominal.

3
 TTL DEVICES

TYPES SN54125, SN54126, SN74125, SN74126

QUADRUPLE BUS BUFFERS WITH 3-STATE OUTPUTS

recommended operating conditions

	SN54125, SN54126			SN74125, SN74126			UNIT
	MIN	NOM	MAX	MIN	NOM	MAX	
V _{CC} Supply voltage	4.5	5	5.5	4.75	5	5.25	V
V _{IH} High-level input voltage	2			2			V
V _{IL} Low-level input voltage			0.8			0.8	V
I _{OH} High-level output current			-2			-5.2	mA
I _{OL} Low-level output current			16			16	mA
T _A Operating free-air temperature	-55		125	0		70	°C

electrical characteristics over recommended operating free-air temperature range (unless otherwise noted)

PARAMETER	TEST CONDITIONS †	SN54125, SN54126		SN74125, SN74126		UNIT		
		MIN	TYP‡	MAX	MIN		TYP‡	MAX
V _{IK}	V _{CC} = MIN, I _I = -12 mA			-1.5		-1.5	V	
V _{OH}	V _{CC} = MIN, V _{IH} = 2 V, V _{IL} = 0.8 V	I _{OH} = -2 V		2.4	3.3		V	
		I _{OH} = -5.2 V				2.4		3.1
V _{OL}	V _{CC} = MIN, V _{IH} = 2 V, V _{IL} = 0.8 V, I _{OL} = 16 mA			0.4		0.4	V	
I _{OZ}	V _{CC} = MAX, V _{IH} = 2 V, V _{IL} = 0.8 V	V _O = 2.4 V		40		40	μA	
		V _O = 0.4 V		-40		-40		
I _I	V _{CC} = MAX, V _I = 5.5 V			1		1	mA	
I _{IH}	V _{CC} = MAX, V _I = 2.4 V			40		40	μA	
I _{IL}	V _{CC} = MAX, V _I = 0.4 V			-1.6		-1.6	mA	
I _{OS} §	V _{CC} = MAX	-30		-70	-28	-70	mA	
I _{CC}	V _{CC} = MAX, (see Note 2)	'125		32	54	32	54	mA
		'126		36	62	36	62	

† For condition shown as MIN or MAX, use the appropriate value specified under recommended operating conditions.

‡ All typical values are at V_{CC} = 5 V, T_A = 25°C.

§ Not more than one output should be shorted at 2 time.

NOTE 2: Data inputs = 0 V; output control = 4.5 V for '125 and 0 V for '126.

switching characteristics, V_{CC} = 5 V, T_A = 25°C (see note 3)

PARAMETER	TEST CONDITIONS	SN54/74125			SN54/74126			UNIT
		MIN	TYP	MAX	MIN	TYP	MAX	
t _{PLH}	R _L = 400 Ω, C _L = 50 pF	8	13		8	13	ns	
t _{PHL}		12	18		12	18	ns	
t _{PZH}		11	17		11	18	ns	
t _{PZL}	R _L = 400 Ω, C _L = 5 pF	16	25		16	25	ns	
t _{PHZ}		5	8		10	16	ns	
t _{PLZ}		7	12		12	18	ns	

NOTE 3: See General Information Section for load circuits and voltage waveforms.

TYPES SN54LS125A, SN54LS126A, SN74LS125A, SN74LS126A QUADRUPLE BUS BUFFERS WITH 3-STATE OUTPUTS

recommended operating conditions

	SN54LS125A SN54LS126A			SN74LS125A SN74LS126A			UNIT
	MIN	NOM	MAX	MIN	NOM	MAX	
V _{CC} Supply voltage	4.5	5	5.5	4.75	5	5.25	V
V _{IH} High-level input voltage	2			2			V
V _{IL} Low-level input voltage	0.7			0.8			V
I _{OH} High-level output current	-1			-2.6			mA
I _{OL} Low-level output current	12			24			mA
T _A Operating free-air temperature	-55 125			0 70			°C

electrical characteristics over recommended operating free-air temperature range (unless otherwise noted)

PARAMETER	TEST CONDITIONS†		SN54LS125A SN54LS126A			SN74LS125A SN74LS126A			UNIT
			MIN	TYP‡	MAX	MIN	TYP‡	MAX	
V _{IK}	V _{CC} = MIN,	I _I = -18 mA	-1.5			-1.5			V
V _{OH}	V _{CC} = MIN,	V _{IL} = 0.7 V, I _{OH} = -1 mA	2.4						V
	V _{IH} = 2 V,	V _{IL} = 0.8 V, I _{OH} = -2.6 mA				2.4			
V _{OL}	V _{CC} = MIN, V _{IH} = 2 V	V _{IL} = 0.7 V, I _{OL} = 12 mA	0.25		0.4				V
		V _{IL} = 0.8 V, I _{OL} = 12 mA			0.25		0.4		
		V _{IL} = 0.8 V, I _{OL} = 24 mA			0.35		0.5		
I _{OZ}	V _{CC} = MAX, V _{IH} = 2 V	V _{IL} = 0.7 V	V _O = 2.4 V		20				μA
			V _O = 0.4 V		-20				
		V _{IL} = 0.8 V	V _O = 2.4 V		20				
			V _O = 0.4 V		-20				
I _I	V _{CC} = MAX,	V _I = 7 V	0.1			0.1			mA
I _{IH}	V _{CC} = MAX,	V _I = 2.7 V	20			20			μA
I _{IL}	V _{CC} = MAX, V _I = 0.4 V	'LS125A-G inputs	-0.2			-0.2			mA
		'LS125A-A inputs; 'LS126A-All inputs	-0.4			-0.4			
I _{OS} §	V _{CC} = MAX		-40	-225	-40	-225	mA		
I _{CC}	V _{CC} = MAX, (see Note 2)	'LS125A	11	20	11	20	mA		
		'LS126A	12	22	12	22			

† For conditions shown as MIN or MAX, use the appropriate value specified under recommended operating conditions.

‡ All typical values are at V_{CC} = 5 V, T_A = 25°C.

§ Not more than one output should be shorted at a time, and duration of the short circuit should not exceed one second.

NOTE 2: Data inputs = 0 V; Output controls = 4.5 V for 'LS125A and 0 V for 'LS126A.

switching characteristics, V_{CC} = 5 V, T_A = 25°C (see note 3)

PARAMETER	TEST CONDITIONS		SN54/74LS125A		SN54/74LS126A		UNIT
			MIN	TYP	MAX	MIN	
t _{PLH}	R _L = 667 Ω,	C _L = 45 pF	9	15	9	15	ns
t _{PHL}			7	18	8	18	ns
t _{PZH}			12	20	16	25	ns
t _{PZL}			15	25	21	35	ns
t _{PHZ}	R _L = 667 Ω,	C _L = 5 pF	20		25		ns
t _{PLZ}			20		25		ns

NOTE 3: See General Information Section for load circuits and voltage waveforms.

3

TTL DEVICES

TYPES SN54128, SN74128 LINE DRIVERS

REVISED DECEMBER 1983

- Package Options Include Plastic and Ceramic DIPs
- Dependable Texas Instruments Quality and Reliability

SN54128 . . . J OR W PACKAGE

SN74128 . . . J OR N PACKAGE

(TOP VIEW)

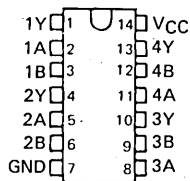

description

These devices contain four independent 2-input-NOR line drivers. They perform the Boolean function $Y = A + B$. The SN54128 is designed to drive 75 ohm lines. The SN74128 is designed to drive 50 ohm lines.

The SN54128 is characterized for operation over the full military temperature range of -55°C to 125°C . The SN74128 is characterized for operation from 0°C to 70°C .

logic diagram (each driver)



schematic (each driver)

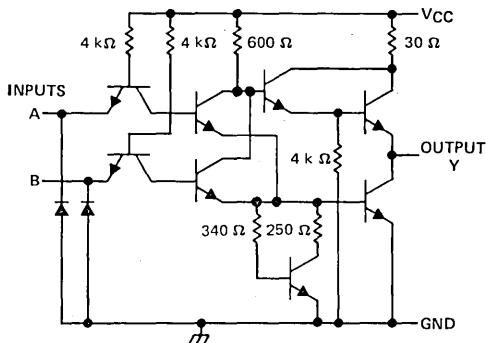

Resistor values shown are nominal.

absolute maximum ratings over operating free-air temperature range (unless otherwise noted)

Supply voltage, V_{CC} (see Note 1)	7 V
Input voltage	5.5 V
Operating free-air temperature range: SN54'	-55°C to 125°C
SN74'	0°C to 70°C
Storage temperature range	-65°C to 150°C

NOTE 1: Voltage values are with respect to network ground terminal.

PRODUCTION DATA

This document contains information current as of publication date. Products conform to these specifications per the terms of Texas Instruments standard warranty. Production processing does not necessarily include testing of all parameters.

TEXAS
INSTRUMENTS

POST OFFICE BOX 225012 • DALLAS, TEXAS 75265

recommended operating conditions

		SN54128			SN74128			UNIT
		MIN	NOM	MAX	MIN	NOM	MAX	
V _{CC}	Supply voltage	4.5	5	5.5	4.75	5	5.25	V
V _{IH}	High-level input voltage	2			2			V
V _{IL}	Low-level input voltage				0.8			V
I _{OH}	High-level output current				-29			mA
I _{OL}	Low-level output current				48			mA
T _A	Operating free-air temperature	-55			125			°C

electrical characteristics over recommended operating free-air temperature range (unless otherwise noted)

PARAMETER	TEST CONDITIONS †	MIN	TYP‡	MAX	UNIT		
V _{IK}	V _{CC} = MIN, I _I = -12 mA				-1.5	V	
V _{OH}	V _{CC} = MIN, V _{IL} = 0.8 V, I _{OH} = -2.4 mA	2.4	3.4				
	V _{CC} = MIN, V _{IL} = 0.4 V, I _{OH} = -13.2 mA	2.4					
	V _{CC} = MIN, V _{IL} = 0.4 V, I _{OH} = MAX	2					
V _{OL}	V _{CC} = MIN, V _{IH} = 2 V, I _{OL} = 48 mA	0.26			0.4	V	
I _I	V _{CC} = MAX, V _I = 5.5 V				1	mA	
I _{IH}	V _{CC} = MAX, V _I = 2.4 V				40	μA	
I _{IL}	V _{CC} = MAX, V _I = 0.4 V				-1.6	mA	
I _{OS} §	V _{CC} = MAX	-70			-180	mA	
I _{CCH}	V _{CC} = MAX				12	21	mA
I _{CCL}	V _{CC} = MAX				33	57	mA

† For conditions shown as MIN or MAX, use the appropriate value specified under recommended operating conditions.

‡ All typical values are at V_{CC} = 5 V, T_A = 25°C.

§ Not more than one output should be shorted at a time.

switching characteristics, V_{CC} = 5 V, T_A = 25°C (see note 2)

PARAMETER	FROM (INPUT)	TO (OUTPUT)	TEST CONDITIONS		MIN	TYP	MAX	UNIT
t _{PLH}	A or B	Y	R _L = 133 Ω,	C _L = 50 pF	6	9		ns
t _{PHL}					8	12		ns
t _{PLH}			R _L = 133 Ω,	C _L = 150 pF	10	15		ns
t _{PHL}					12	18		ns

NOTE 2: See General Information Section for load circuits and voltage waveforms.

3
TTL DEVICES

TYPES SN54132, SN54LS132, SN54S132, SN74132, SN74LS132, SN74S132 QUADRUPLE 2-INPUT POSITIVE-NAND SCHMITT TRIGGERS

REVISED DECEMBER 1983

- Operation from Very Slow Edges
- Improved Line-Receiving Characteristics
- High Noise Immunity

description

Each circuit functions as a 2-input NAND gate, but because of the Schmitt action, it has different input threshold levels for positive (V_{T+}) and for negative going (V_{T-}) signals.

These circuits are temperature-compensated and can be triggered from the slowest of input ramps and still give clear, jitter-free output signals.

The SN54132, SN54LS132, and SN54S132 are characterized for operation over the full military temperature range of -55°C to 125°C . The SN74132, SN74LS132, and SN74S132 are characterized for operation from 0°C to 70°C .

logic diagram (each gate)

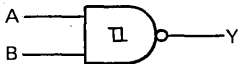

positive logic

$$Y = \overline{AB}$$

SN54132, SN54LS132, SN54S132 ... J OR W PACKAGE
SN74132 ... J OR N PACKAGE
SN74LS132, SN74S132 ... D, J OR N PACKAGE
(TOP VIEW)

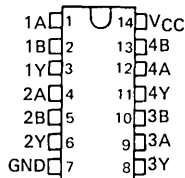

SN54LS132, SN54S132 ... FK PACKAGE
SN74LS132, SN74S132 ... FN PACKAGE
(TOP VIEW)

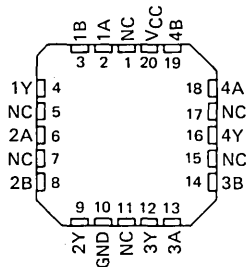

NC-No internal connection



TTL DEVICES

**TYPES SN54132, SN54LS132, SN54S132,
SN74132, SN74LS132, SN74S132
QUADRUPLE 2-INPUT POSITIVE-NAND SCHMITT TRIGGERS**

schematics

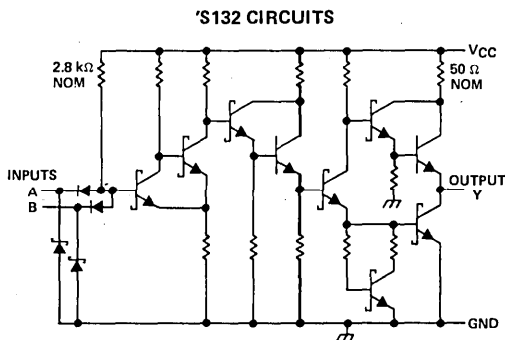
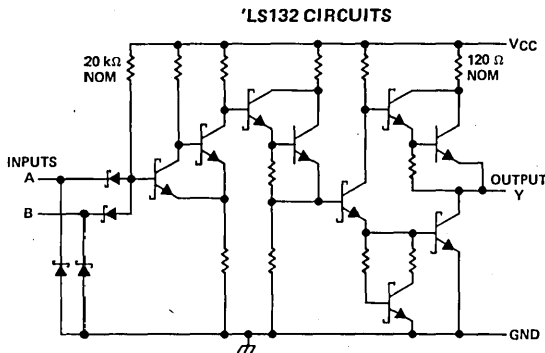
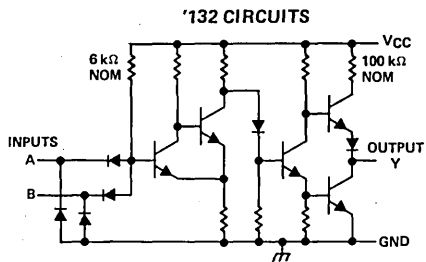

Resistor values shown are nominal.

absolute maximum ratings over operating free-air temperature range (unless otherwise noted)

Supply voltage, V_{CC} (see Note 1).....	7 V
Input voltage: '132, 'S132.....	5.5 V
'LS132.....	7 V
Operating free-air temperature: SN54'.....	-55°C to 125°C
SN74'.....	0°C to 70°C
Storage temperature range.....	-65°C to 150°C

NOTE 1: Voltages values are with respect to network ground terminal.

3

TTL DEVICES

TYPES SN54132, SN74132 QUADRUPLE 2-INPUT POSITIVE-NAND SCHMITT TRIGGERS

recommended operating conditions

	SN54132			SN74132			UNIT
	MIN	NOM	MAX	MIN	NOM	MAX	
V _{CC} Supply voltage	4.5	5	5.5	4.75	5	5.25	V
I _{OH} High-level output current			-0.8			-0.8	mA
I _{OL} Low-level output current			16			16	mA
T _A Operating free-air temperature	-55		125	0		70	°C

electrical characteristics over recommended operating free-air temperature range (unless otherwise noted)

PARAMETER	TEST CONDITIONS†	MIN	TYP‡	MAX	UNIT
V _{T+}	V _{CC} = 5 V	1.5	1.7	2	V
V _{T-}	V _{CC} = 5 V	0.6	0.9	1.1	V
Hysteresis (V _{T+} - V _{T-})	V _{CC} = 5 V	0.4	0.8		V
V _{IK}	V _{CC} = MIN, I _I = -12 mA			-1.5	V
V _{OH}	V _{CC} = MIN, V _I = 0.6 V, I _{OH} = -0.8 mA	2.4	3.4		V
V _{OL}	V _{CC} = MIN, V _I = 2 V, I _{OL} = 16 mA		0.2	0.4	V
I _{T+}	V _{CC} = 5 V, V _I = V _{T+}	-0.43			mA
I _{T-}	V _{CC} = 5 V, V _I = V _{T-}	-0.56			mA
I _I	V _{CC} = MAX, V _I = 5.5 V			1	mA
I _{IH}	V _{CC} = MAX, V _I = 2.4 V			40	μA
I _{IL}	V _{CC} = MAX, V _I = 0.4 V	-0.8	-1.2		mA
I _{OS} §	V _{CC} = MAX	-18		-55	mA
I _{CCH}	V _{CC} = MAX		15	24	mA
I _{CCL}	V _{CC} = MAX		26	40	mA

† For conditions shown as MIN or MAX, use the appropriate value specified under recommended operating conditions.

‡ All typical values are at V_{CC} = 5 V, T_A = 25°C.

§ Not more than one output should be shorted at a time.

switching characteristics, V_{CC} = 5 V, T_A = 25°C (see figure 1)

PARAMETER	FROM (INPUT)	TO (OUTPUT)	TEST CONDITIONS	MIN	TYP	MAX	UNIT
t _{PLH}	Any	Y	R _L = 400 Ω, C _L = 15 pF	15	22		ns
t _{PHL}				15	22		ns

3

TTL DEVICES

TYPES SN54LS132, SN74LS132 QUADRUPLE 2-INPUT POSITIVE-NAND SCHMITT TRIGGERS

recommended operating conditions

	SN54LS132			SN74LS132			UNIT
	MIN	NOM	MAX	MIN	NOM	MAX	
V _{CC} Supply voltage	4.5	5	5.5	4.75	5	5.25	V
I _{OH} High-level output current			-0.4			-0.4	mA
I _{OL} Low-level output current			4			8	mA
T _A Operating free-air temperature	-55		125	0		70	°C

electrical characteristics over recommended operating free-air temperature range (unless otherwise noted)

PARAMETER	TEST CONDITIONS†	SN54LS132			SN74LS132			UNIT
		MIN	TYP‡	MAX	MIN	TYP‡	MAX	
V _{T+}	V _{CC} = 5 V	1.4	1.6	1.9	1.4	1.6	1.9	V
V _{T-}	V _{CC} = 5 V	0.5	0.8	1	0.5	0.8	1	V
Hysteresis (V _{T+} - V _{T-})	V _{CC} = 5 V	0.4	0.8		0.4	0.8		V
V _{IK}	V _{CC} = MIN, I _I = -18 mA			-1.5			-1.5	V
V _{OH}	V _{CC} = MIN, V _I = 0.5 V, I _{OH} = -0.4 mA	2.5	3.4		2.7	3.4		V
V _{OL}	V _{CC} = MIN, V _I = 1.9 V	I _{OL} = 4 mA		0.25	0.4	0.25	0.4	V
		I _{OL} = 8 mA				0.35	0.5	
I _{T+}	V _{CC} = 5 V, V _I = V _{T+}	-0.14			-0.14			mA
I _{T-}	V _{CC} = 5 V, V _I = V _{T-}	-0.18			-0.18			mA
I _I	V _{CC} = MAX, V _I = 7 V	0.1			0.1			mA
I _{IH}	V _{CC} = MAX, V _I = 2.7 V	20			20			µA
I _{IL}	V _{CC} = MAX, V _{IL} = 0.4 V	-0.4			-0.4			mA
I _{OS} §	V _{CC} = MAX	-20		-100	-20		-100	mA
I _{CCH}	V _{CC} = MAX	5.9 11		5.9 11				mA
I _{CCL}	V _{CC} = MAX	8.2 14		8.2 14				mA

† For conditions shown as MIN or MAX, use the appropriate value specified under recommended operating conditions.

‡ All typical values are at V_{CC} = 5 V, T_A = 25° C.

§ Not more than one output should be shorted at a time, and duration of the short-circuit should not exceed one second

switching characteristics, V_{CC} = 5 V, T_A = 25° C (see figure 1)

PARAMETER	FROM (INPUT)	TO (OUTPUT)	TEST CONDITIONS	MIN	TYP	MAX	UNIT
t _{PLH}	Any	Y	R _L = 2 kΩ, C _L = 15 pF	15	22		ns
t _{PHL}				15	22		ns

3

TTL DEVICES

TYPES SN54S132, SN74S132 QUADRUPLE 2-INPUT POSITIVE-NAND SCHMITT TRIGGERS

recommended operating conditions

	SN54S132			SN74S132			UNIT
	MIN	NOM	MAX	MIN	NOM	MAX	
V _{CC} Supply voltage	4.5	5	5.5	4.75	5	5.25	V
I _{OH} High-level output current	-1			-1			mA
I _{OL} Low-level output current	20			20			mA
T _A Operating free-air temperature	-55	125		0	70		°C

electrical characteristics over recommended operating free-air temperature range (unless otherwise noted)

PARAMETER	TEST CONDITIONS†	SN54S132			SN74S132			UNIT
		MIN	TYP‡	MAX	MIN	TYP‡	MAX	
V _{T+}	V _{CC} = 5 V	1.6	1.77	1.9	1.6	1.77	1.9	V
V _{T-}	V _{CC} = 5 V	1.1	1.22	1.4	1.1	1.22	1.4	V
Hysteresis (V _{T+} - V _{T-})	V _{CC} = 5 V	0.2	0.55		0.2	0.55		V
V _{IK}	V _{CC} = MIN, I _I = -18 mA	-1.2			-1.2			V
V _{OH}	V _{CC} = MIN, V _I = 1.1 V, I _{OH} = -1 mA	2.5	3.4		2.7	3.4		V
V _{OL}	V _{CC} = MIN, V _I = 1.9 V, I _{OL} = 20 mA	0.5			0.5			V
I _{T+}	V _{CC} = 5 V, V _I = V _{T+}	-0.9			-0.9			mA
I _{T-}	V _{CC} = 5 V, V _I = V _{T-}	-1.1			-1.1			mA
I _I	V _{CC} = MAX, V _I = 5.5 V	1			1			mA
I _{IH}	V _{CC} = MAX, V _I = 2.7 V	50			50			µA
I _{IL}	V _{CC} = MAX, V _I = 0.5 V	-2			-2			mA
I _{OS} §	V _{CC} = MAX	-40	-100		-40	-100		mA
I _{CCH}	V _{CC} = MAX	28 44			28 44			mA
I _{CCL}	V _{CC} = MAX	44 68			44 68			mA

† For conditions shown as MIN or MAX, use the appropriate value specified under recommended operating conditions.

‡ All typical values are at V_{CC} = 5 V, T_A = 25°C.

§ Not more than one output should be shorted at a time, and duration of the short-circuit should not exceed one second.

switching characteristics, V_{CC} = 5 V, T_A = 25°C (see figure 1)

PARAMETER	FROM (INPUT)	TO (OUTPUT)	TEST CONDITIONS		MIN	TYP	MAX	UNIT
t _{PLH}	A or B	Y	R _L = 280 Ω,	C _L = 15 pF	7		10.5	ns
t _{PHL}					8.5	13	ns	

TTL DEVICES

TYPES SN54132, SN54LS132, SN54S132,
 SN74132, SN74LS132, SN74S132
 QUADRUPLE 2-INPUT POSITIVE-NAND SCHMITT TRIGGERS

PARAMETER MEASUREMENT INFORMATION

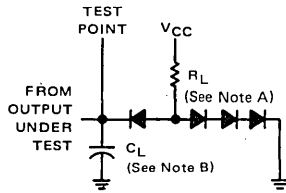

LOAD CIRCUIT

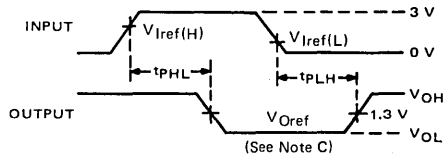

VOLTAGE WAVEFORMS

- NOTES: A. All diodes are 1N3064 or equivalent.
 B. C_L includes probe and jig capacitance.
 C. Generator characteristics and reference voltages are:

	Generator Characteristics				Reference Voltages		
	Z_{out}	PRR	t_r	t_f	$V_{I\ ref(H)}$	$V_{I\ ref(L)}$	$V_{O\ ref}$
SN54*/SN74*	50	1 MHz	10 ns	10 ns	1.7 V	0.9 V	1.5 V
SN54LS*/SN74LS*	50	1 MHz	15 ns	6 ns	1.6 V	0.8 V	1.3 V
'S132	50	1 MHz	2.5 ns	2.5 ns	1.8 V	1.2 V	1.5 V

FIGURE 1

TYPES SN54132, SN74132
 QUADRUPLE 2-INPUT POSITIVE-NAND SCHMITT TRIGGERS

TYPICAL CHARACTERISTICS OF '132 CIRCUITS

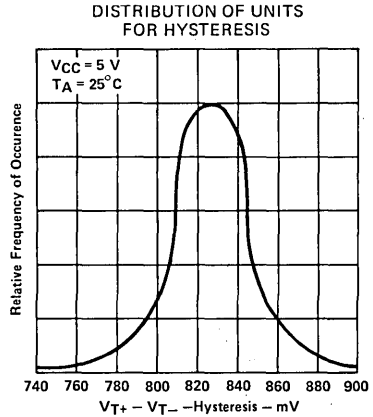
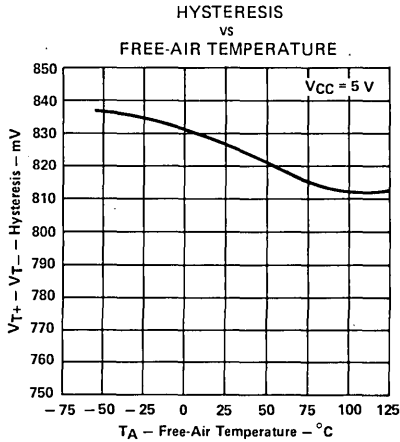
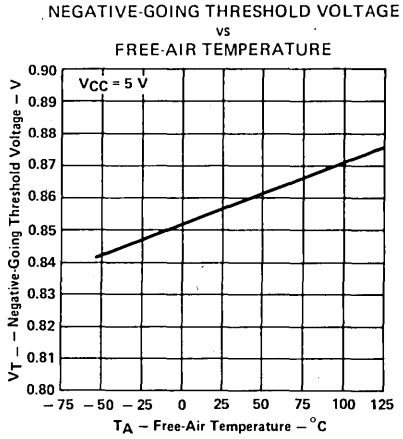
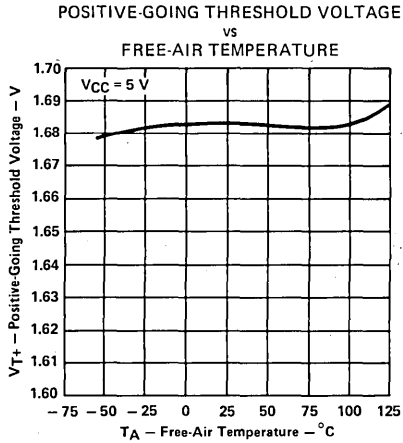

† Data for temperatures below 0°C and 70°C and supply below 4.75 V and above 5.25 V are applicable for SN54132 only.

TYPES SN54132, SN74132
 QUADRUPLE 2-INPUT POSITIVE-NAND SCHMITT TRIGGERS

TYPICAL CHARACTERISTICS OF '132 CIRCUITS

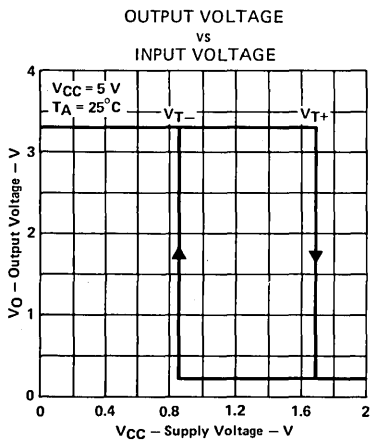
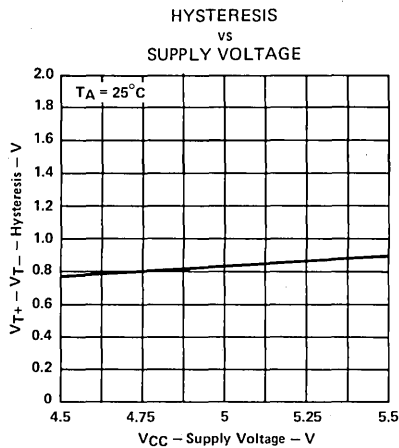
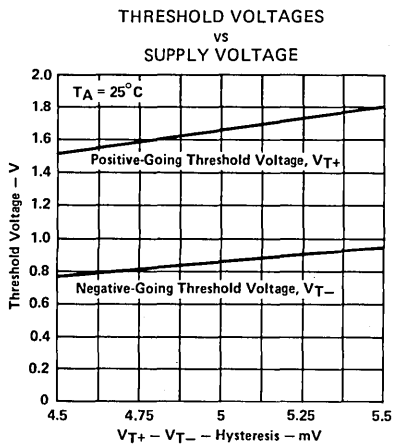

† Data for temperatures below 0°C and 70°C and supply below 4.75 V and above 5.25 V are applicable for SN54132 only.

TYPES SN54LS132, SN74LS132 QUADRUPLE 2-INPUT POSITIVE-NAND SCHMITT TRIGGERS

TYPICAL CHARACTERISTICS OF 'LS132 CIRCUITS

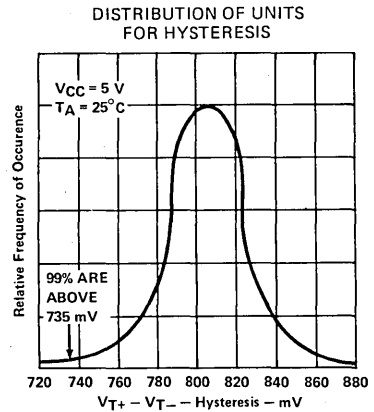
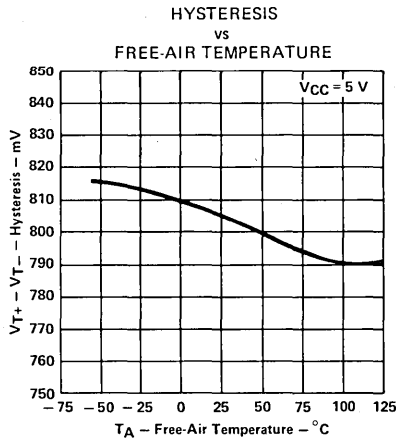
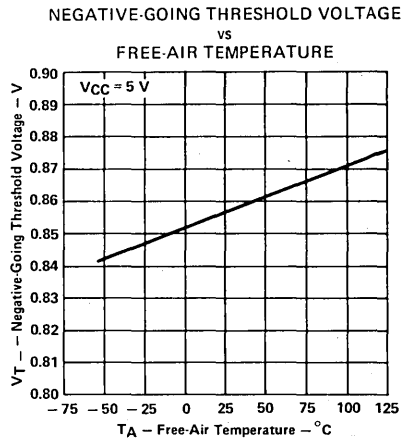
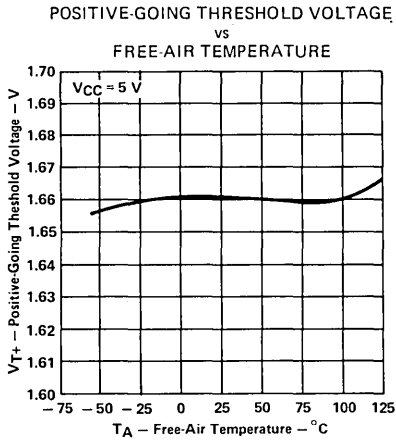

† Data for temperatures below 0°C and above 70°C and supply voltages below 4.75 V and above 5.25 V are applicable for SN54LS132 only.

TYPES SN54LS132, SN74LS132
QUADRUPLE 2-INPUT POSITIVE-NAND SCHMITT TRIGGERS

TYPICAL CHARACTERISTICS OF 'LS132 CIRCUITS

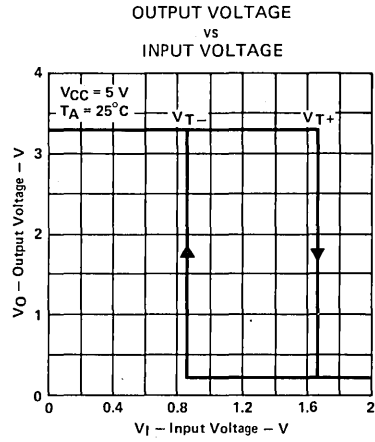
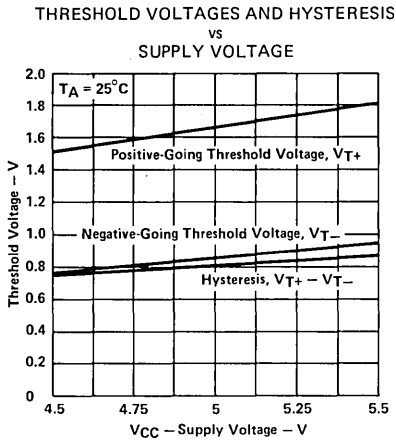

3

TTL DEVICES

† Data for temperatures below 0°C and above 70°C and supply voltages below 4.75 V and above 5.25 V are applicable for SN54LS132 only.

TYPES SN54132, SN54LS132, SN54S132,
SN74132, SN74LS132, SN74S132
QUADRUPLE 2-INPUT POSITIVE-NAND SCHMITT TRIGGERS

TYPICAL APPLICATION DATA

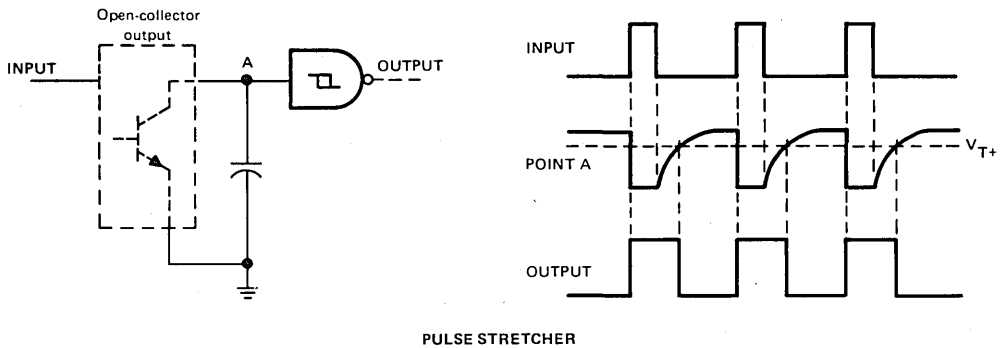
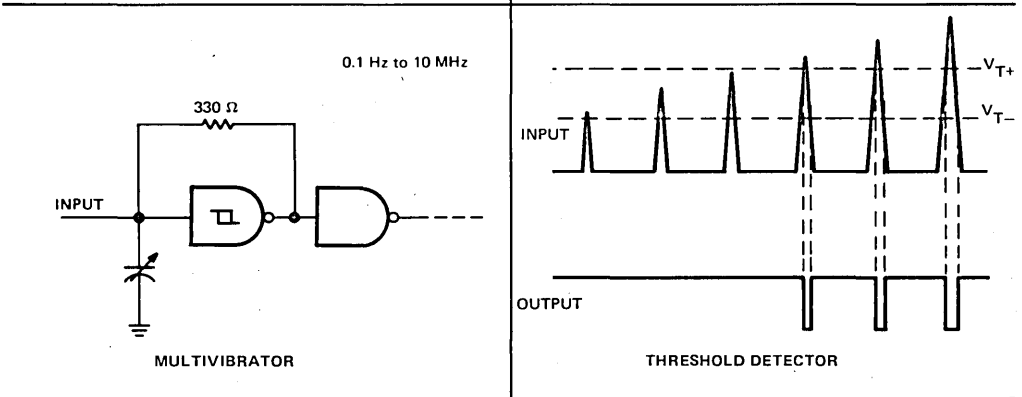
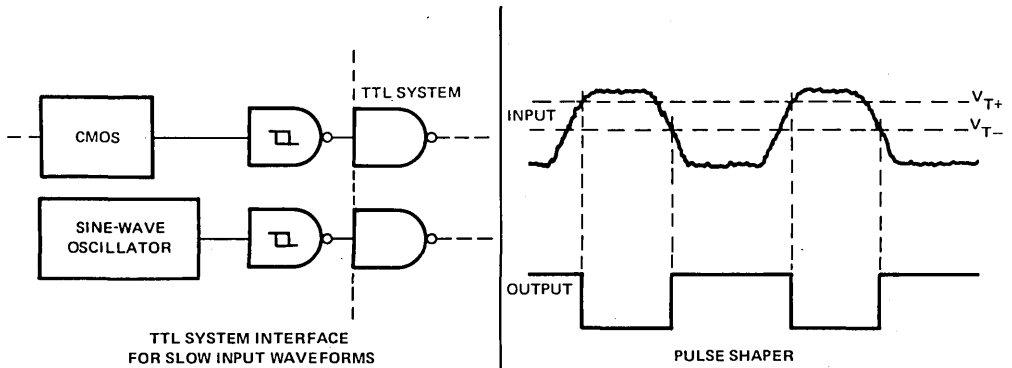

3
TTL DEVICES

TYPES SN54S133, SN74S133 13-INPUT POSITIVE-NAND GATES

REVISED DECEMBER 1983

- Package Options Include Both Plastic and Ceramic Chip Carriers in Addition to Plastic and Ceramic DIPs
- Dependable Texas Instruments Quality and Reliability

description

These devices contain a single 13-input NAND gate.

The SN54133 is characterized for operation over the full military temperature range of -55°C to 125°C . The SN74133 is characterized for operation from 0°C to 70°C .

FUNCTION TABLE

INPUTS A THRU M	OUTPUT Y
All inputs H	L
One or more inputs L	H

logic diagram

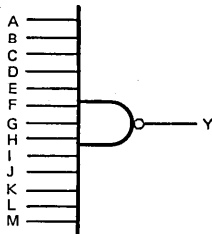

positive logic

$$Y = \overline{A \cdot B \cdot C \cdot D \cdot E \cdot F \cdot G \cdot H \cdot I \cdot J \cdot K \cdot L \cdot M} \text{ or } \overline{A + B + C + D + E + F + G + H + I + J + K + L + M}$$

SN54S133 ... J OR W PACKAGE
SN74S133 ... D, J OR N PACKAGE
(TOP VIEW)

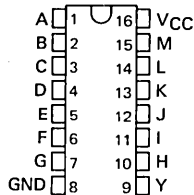

SN54S133 ... FK PACKAGE
SN74S133 ... FN PACKAGE
(TOP VIEW)

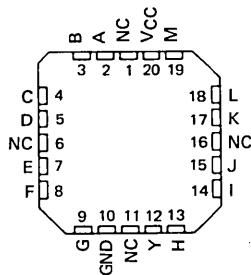

NC - No internal connection

3

TTL DEVICES

TYPES SN54S133, SN74S133 13-INPUT POSITIVE-NAND GATES

schematic

'S133

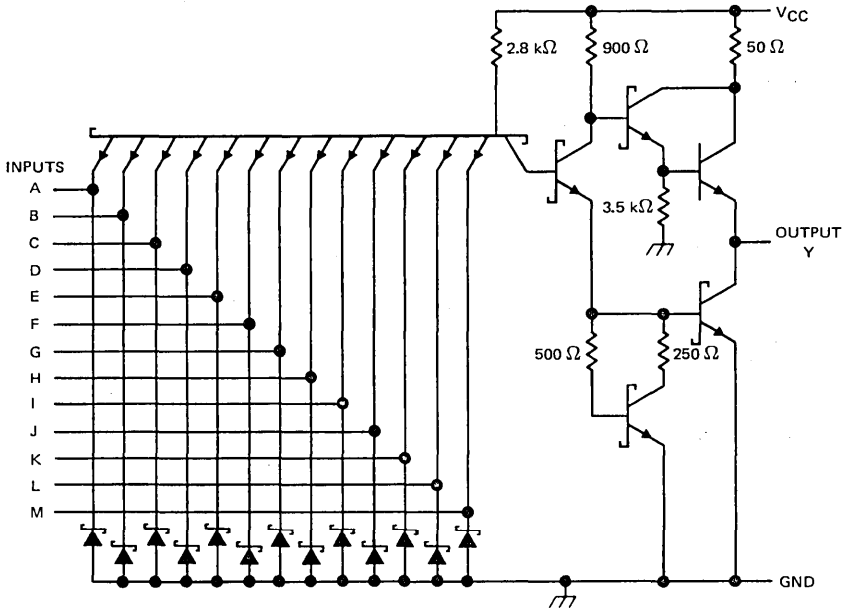

Resistor values shown are nominal.

absolute maximum ratings over operating free-air temperature range (unless otherwise noted)

Supply voltage, V_{CC} (see Note 1)	7 V
Input voltage	5.5 V
Operating free-air temperature range: SN54'	-55°C to 125°C
SN74'	0°C to 70°C
Storage temperature range	-65°C to 150°C

NOTE 1: Voltage values are with respect to network ground terminal.

3

TTL DEVICES

TYPES SN54S133, SN74S133 13-INPUT POSITIVE-NAND GATES

recommended operating conditions

	SN54S133			SN74S133			UNIT
	MIN	NOM	MAX	MIN	NOM	MAX	
V _{CC} Supply voltage	4.5	5	5.5	4.75	5	5.25	V
V _{IH} High-level input voltage	2			2			V
V _{IL} Low-level input voltage			0.8			0.8	V
I _{OH} High-level output current			-1			-1	mA
I _{OL} Low-level output current			20			20	mA
T _A Operating free-air temperature	-55		125	0		70	°C

electrical characteristics over recommended operating free-air temperature range (unless otherwise noted)

PARAMETER	TEST CONDITIONS †	SN54S133			SN74S133			UNIT
		MIN	TYP‡	MAX	MIN	TYP‡	MAX	
V _{IK}	V _{CC} = MIN, I _I = -18 mA			-1.2			-1.2	V
V _{OH}	V _{CC} = MIN, V _{IL} = 0.8 V, I _{OH} = -1 mA	2.5	3.4		2.7	3.4		V
V _{OL}	V _{CC} = MIN, V _{IH} = 2 V, I _{OL} = 20 mA			0.5			0.5	V
I _I	V _{CC} = MAX, V _I = 5.5 V			1			1	mA
I _{IH}	V _{CC} = MAX, V _I = 2.7 V			50			50	µA
I _{IL}	V _{CC} = MAX, V _I = 0.5 V			-2			-2	mA
I _{OS} §	V _{CC} = MAX	-40		-100	-40		-100	mA
I _{CCH}	V _{CC} = MAX, V _I = 0 V		3	5		3	5	mA
I _{CCL}	V _{CC} = MAX, V _I = 4.5 V		5.5	10		5.5	10	mA

† For conditions shown as MIN or MAX, use the appropriate value specified under recommended operating conditions.

‡ All typical values are at V_{CC} = 5 V, T_A = 25°C.

§ Not more than one output should be shorted at a time, and the duration of the short-circuit should not exceed one second.

switching characteristics, V_{CC} = 5 V, T_A = 25°C (see note 2)

PARAMETER	FROM (INPUT)	TO (OUTPUT)	TEST CONDITIONS	MIN	TYP	MAX	UNIT
t _{PLH}	Any	Y	R _L = 280 Ω, C _L = 15 pF		4	6	ns
t _{PHL}					4.5	7	ns
t _{PLH}			R _L = 280 Ω, C _L = 50 pF		5.5		ns
t _{PHL}					6.5		ns

NOTE 2: See General Information Section for load circuits and voltage waveforms.

3

TTL DEVICES

TYPES SN54S134, SN74S134
12-INPUT POSITIVE-NAND GATES WITH 3-STATE OUTPUTS

schematic

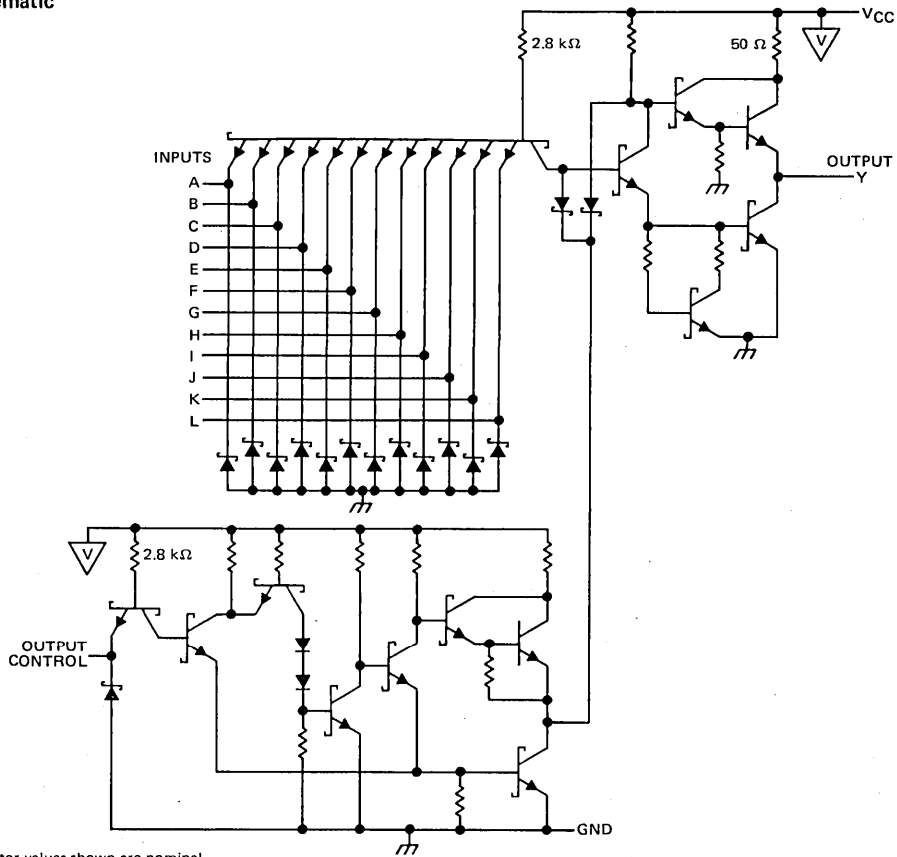

Resistor values shown are nominal.

absolute maximum ratings over operating free-air temperature range (unless otherwise noted)

Supply voltage, V_{CC} (see Note 1).....	7 V
Input voltage	5.5 V
Voltage applied to a disabled 3-state output	5.5 V
Operating free-air temperature range: SN54'	-55°C to 125°C
SN74'	0°C to 70°C
Storage temperature range	-65°C to 150°C

NOTE 1: Voltage values are with respect to network ground terminal.

3 TTL DEVICES

TYPES SN54S134, SN74S134 12-INPUT POSITIVE-NAND GATES WITH 3-STATE OUTPUTS

recommended operating conditions

	SN54S134			SN74S134			UNIT
	MIN	NOM	MAX	MIN	NOM	MAX	
V _{CC} Supply voltage	4.5	5	5.5	4.75	5	5.25	V
V _{IH} High-level input voltage	2			2			V
V _{IL} Low-level input voltage				0.8			V
I _{OH} High-level output current				-2			-6.5 mA
I _{OL} Low-level output current				20			20 mA
T _A Operating free-air temperature	-55			125			0 70 °C

electrical characteristics over recommended operating free-air temperature range (unless otherwise noted)

PARAMETER	TEST CONDITIONS†	SN54S134		SN74S134		UNIT
		MIN	TYP‡	MAX	MIN	
V _{IK}	V _{CC} = MIN, I _I = -18 mA			-1.2		V
V _{OH}	V _{CC} = MIN, V _{IH} = 2 V, V _{IL} = 0.8 V	I _{OH} = -2 mA		2.4 3.4		V
		I _{OH} = -6.5 mA		2.4 3.2		
V _{OL}	V _{CC} = MIN, V _{IH} = 2 V, I _{OL} = 20 mA, V _{IL} = 0.8 V			0.5		V
I _{OZ}	V _{CC} = MAX, V _{IH} = 2 V, V _{IL} = 0.8 V	V _O = 2.4 V		50		μA
		V _O = 0.5 V		-50		
I _I	V _{CC} = MAX, V _I = 5.5 V			1		1 mA
I _{IH}	V _{CC} = MAX, V _I = 2.7 V			50		50 μA
I _{IL}	V _{CC} = MAX, V _I = 0.5 V			-2		-2 mA
I _{OS} §	V _{CC} = MAX	-40	-100	-40	-100	mA
I _{CC}	V _{CC} = MAX	Outputs high		7	13	7 13
		Outputs low		9	16	9 16
		Outputs disabled		14	25	14 25

† For conditions shown as MIN or MAX, use the appropriate value specified under recommended operating conditions.

‡ All typical values are at V_{CC} = 5 V, T_A = 25°C.

§ Not more than one output should be shorted at a time, and duration of the short circuit should not exceed one second.

switching characteristics, V_{CC} = 5 V, T_A = 25°C (see note 2)

PARAMETER	TEST CONDITIONS	SN54S134		SN74S134		UNIT
		MIN	TYP	MAX	MIN	
t _{PLH}	R _L = 280 Ω, C _L = 15 pF	4 6		4 6		ns
t _{PLH}	R _L = 280 Ω, C _L = 50 pF	5.5		5.5		ns
t _{PHL}	R _L = 280 Ω, C _L = 15 pF	5 7.5		5 7.5		ns
t _{PHL}	R _L = 280 Ω, C _L = 50 pF	7		7		ns
t _{PZH}	R _L = 280 Ω, C _L = 50 pF	13 19.5		13 19.5		ns
t _{PZL}		14 21		14 21		ns
t _{PHZ}	R _L = 280 Ω, C _L = 5 pF	5.5 8.5		5.5 8.5		ns
t _{PLZ}		9 14		9 14		ns

NOTE 2: See General Information Section for load circuits and voltage waveforms.

3

TTL DEVICES

TYPES SN54S135, SN74S135 QUADRUPLE EXCLUSIVE-OR/NOR GATES

DECEMBER 1972—REVISED DECEMBER 1983

- Fully Compatible with Most TTL and TTL MSI Circuits
- Fully Schottky Clamping Reduces Delay Times . . . 8 ns Typical
- Can Operate as Exclusive-OR Gate (C Input Low) or as Exclusive-NOR Gate (C Input High)

FUNCTION TABLE

INPUTS			OUTPUT
A	B	C	Y
L	L	L	L
L	H	L	H
H	L	L	H
H	H	L	L
L	L	H	H
L	H	H	L
H	L	H	L
H	H	H	H

H = high level, L = low level

logic diagram (one half)

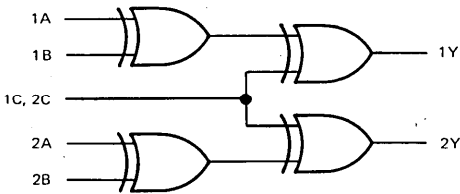

positive logic

$$Y = A \oplus B \oplus C = \bar{A}\bar{B}C + \bar{A}B\bar{C} + A\bar{B}\bar{C} + ABC$$

schematics of inputs and outputs

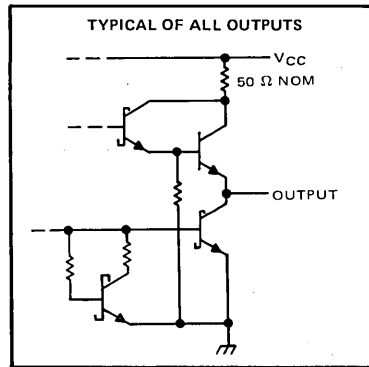
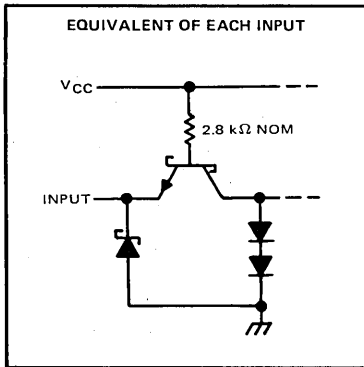

Resistor values shown are nominal.

SN54S135 . . . J OR W PACKAGE
SN74S135 . . . D, J OR N PACKAGE
(TOP VIEW)

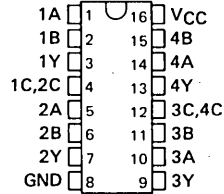

SN54S135 . . . FK PACKAGE
SN74S135 . . . FN PACKAGE
(TOP VIEW)

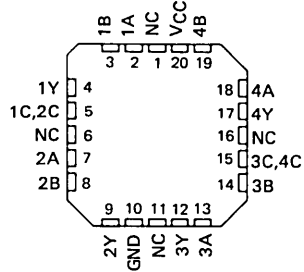

NC - No internal connection

3

TTL DEVICES

TYPES SN54S135, SN74S135 QUADRUPLE EXCLUSIVE-OR/NOR GATES

absolute maximum ratings over operating free-air temperature range (unless otherwise noted)

Supply voltage, V_{CC} (see Note 1)	7 V
Input voltage	5.5 V
Operating free-air temperature range: SN54S135	-55°C to 125°C
SN74S135	0°C to 70°C
Storage temperature range	-65°C to 150°C

NOTE 1: Voltage values are with respect to network ground terminal.

recommended operating conditions

	SN54S135			SN74S135			UNIT
	MIN	NOM	MAX	MIN	NOM	MAX	
Supply voltage, V_{CC}	4.5	5	5.5	4.75	5	5.25	V
High-level output current, I_{OH}			-1			-1	mA
Low-level output current, I_{OL}			20			20	mA
Operating free-air temperature, T_A	-55		125	0		70	$^{\circ}\text{C}$

electrical characteristics over recommended operating free-air temperature range (unless otherwise noted)

PARAMETER	TEST CONDITIONS†	MIN	TYP‡	MAX	UNIT
V_{IH} High-level input voltage		2			V
V_{IL} Low-level input voltage				0.8	V
V_{IK} Input clamp voltage	$V_{CC} = \text{MIN}, I_I = -18 \text{ mA}$			-1.2	V
V_{OH} High-level output voltage	$V_{CC} = \text{MIN}, V_{IH} = 2 \text{ V}, V_{IL} = 0.8 \text{ V}, I_{OH} = -1 \text{ mA}$	SN54S [†] 2.5	3.4		V
V_{OL} Low-level output voltage	$V_{CC} = \text{MIN}, V_{IH} = 2 \text{ V}, V_{IL} = 0.8 \text{ V}, I_{OL} = 20 \text{ mA}$			0.5	V
I_I Input current at maximum input voltage	$V_{CC} = \text{MAX}, V_I = 5.5 \text{ V}$			1	mA
I_{IH} High-level input current	$V_{CC} = \text{MAX}, V_I = 2.7 \text{ V}$			50	μA
I_{IL} Low-level input current	$V_{CC} = \text{MAX}, V_I = 0.5 \text{ V}$			-2	mA
I_{OS} Short-circuit output current §	$V_{CC} = \text{MAX}$	-40		-100	mA
I_{CC} Supply current	$V_{CC} = \text{MAX}$, See Note 2		65	99	mA

†For conditions shown as MIN or MAX, use the appropriate value specified under recommended operating conditions for the applicable type.

‡All typical values are at $V_{CC} = 5 \text{ V}, T_A = 25^{\circ}\text{C}$.

§Not more than one output should be shorted at a time and duration of the short circuit should not exceed one second.

NOTE 2: I_{CC} is measured with the inputs grounded and the outputs open.

switching characteristics, $V_{CC} = 5 \text{ V}, T_A = 25^{\circ}\text{C}$

PARAMETER¶	FROM (INPUT)	TEST CONDITIONS	MIN	TYP	MAX	UNIT
t_{PLH}	A or B	B or A = L, C = L	8.5	13		ns
t_{PHL}			11	15		
t_{PLH}	A or B	B or A = H, C = L	8	12		ns
t_{PHL}			9	13.5		
t_{PLH}	A or B	B or A = L, C = H	10	15		ns
t_{PHL}			6.5	10		
t_{PLH}	A or B	B or A = H, C = H	8.5	12		ns
t_{PHL}			7	13		
t_{PLH}	C	A = B	8	12		ns
t_{PHL}			9.5	14.5		
t_{PLH}	C	A \neq B	7.5	11.5		ns
t_{PHL}			8	12		

¶ t_{PLH} \equiv propagation delay time, low-to-high-level output

¶ t_{PHL} \equiv propagation delay time, high-to-low-level output

NOTE 3: See General Information Section for load circuits and voltage waveforms.

3
TTL DEVICES

TYPES SN54136, SN54LS136, SN74136, SN74LS136 QUADRUPLE 2-INPUT EXCLUSIVE-OR GATES WITH OPEN-COLLECTOR OUTPUTS

DECEMBER 1972—REVISED DECEMBER 1983

FUNCTION TABLE

INPUTS		OUTPUT
A	B	Y
L	L	L
L	H	H
H	L	H
H	H	L

H = high level, L = low level

logic diagram (each gate)



positive logic

$$Y = A \oplus B = \bar{A}B + A\bar{B}$$

SN54136, SN54LS136 ... J OR W PACKAGE
SN74136 ... J OR N PACKAGE
SN74LS136 ... D, J OR N PACKAGE

(TOP VIEW)

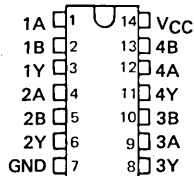

SN54LS136 ... FK PACKAGE
SN74LS136 ... FN PACKAGE

(TOP VIEW)

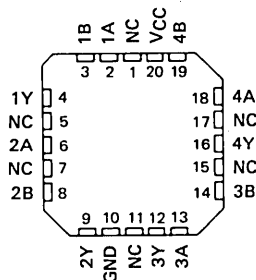

NC - No internal connection

3

TTL DEVICES

schematics of inputs and outputs

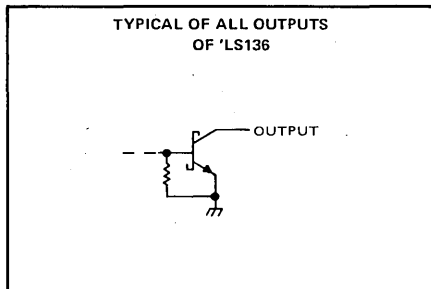
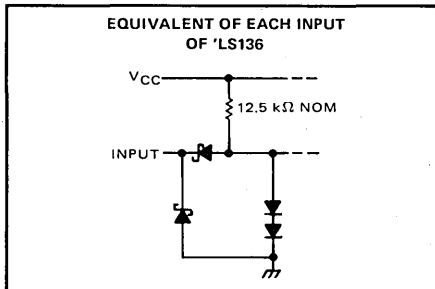
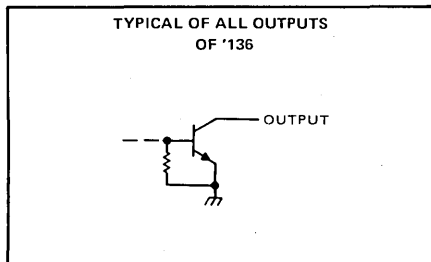
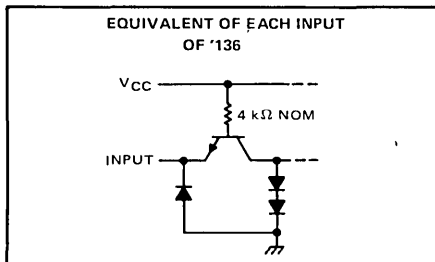

Resistor values shown are nominal.

TYPES SN54LS136, SN74LS136 QUADRUPLE 2-INPUT EXCLUSIVE-OR GATES WITH OPEN-COLLECTOR OUTPUTS

absolute maximum ratings over operating free-air temperature range (unless otherwise noted)

Supply voltage, V_{CC} (see Note 1)	7 V
Input voltage	7 V
Operating free-air temperature range: SN54LS136	-55°C to 125°C
SN74LS136	0°C to 70°C
Storage temperature range	-65°C to 150°C

NOTE 1: Voltage values are with respect to network ground terminal.

recommended operating conditions

	SN54LS136			SN74LS136			UNIT
	MIN	NOM	MAX	MIN	NOM	MAX	
Supply voltage, V_{CC}	4.5	5	5.5	4.75	5	5.25	V
High-level output voltage, V_{OH}	5.5			5.5			V
Low-level output current, I_{OL}	4			8			mA
Operating free-air temperature, T_A	-55	125		0	70		°C

electrical characteristics over recommended operating free-air temperature range (unless otherwise noted)

PARAMETER	TEST CONDITIONS†	SN54LS136		SN74LS136		UNIT	
		MIN	TYP‡	MAX	MIN		TYP‡
V_{IH} High-level input voltage		2		2		V	
V_{IL} Low-level input voltage						0.8	V
V_{IK} Input clamp voltage	$V_{CC} = \text{MIN}, I_I = -18 \text{ mA}$			-1.5		-1.5	V
I_{OH} High-level output current	$V_{CC} = \text{MIN}, V_{IH} = 2 \text{ V}, V_{IL} = V_{IL \text{ max}}, V_{OH} = 5.5 \text{ V}$			100		100	μA
V_{OL} Low-level output voltage	$V_{CC} = \text{MIN}, V_{IH} = 2 \text{ V}, V_{IL} = V_{IL \text{ max}}, I_{OL} = 4 \text{ mA}$	0.25	0.4	0.25	0.4		V
	$V_{CC} = \text{MAX}, I_{OL} = 8 \text{ mA}$			0.35	0.5		
I_I Input current at maximum input voltage	$V_{CC} = \text{MAX}, V_I = 7 \text{ V}$		0.2		0.2		mA
I_{IH} High-level input current	$V_{CC} = \text{MAX}, V_I = 2.7 \text{ V}$		40		40		μA
I_{IL} Low-level input current	$V_{CC} = \text{MAX}, V_I = 0.4 \text{ V}$		-0.8		-0.8		mA
I_{CC} Supply current	$V_{CC} = \text{MAX},$ See Note 2	6.1	10	6.1	10		mA

† For conditions shown as MIN or MAX, use the appropriate value specified under recommended operating conditions for the applicable type.

‡ All typical values are at $V_{CC} = 5 \text{ V}, T_A = 25^\circ \text{C}$.

NOTE 2: I_{CC} is measured with one input of each gate at 4.5 V, the other inputs grounded, and the outputs open.

switching characteristics, $V_{CC} = 5 \text{ V}, T_A = 25^\circ \text{C}$

PARAMETER‡	FROM (INPUT)	TEST CONDITIONS		MIN	TYP	MAX	UNIT
t_{PLH}	A or B	Other input low	$C_L = 15 \text{ pF}, R_L = 2 \text{ k}\Omega,$ (See Note 3)	18	30	ns	
t_{PHL}				18	30		
t_{PLH}	A or B	Other input high		18	30	ns	
t_{PHL}				18	30		

‡ t_{PLH} = propagation delay time, low-to-high-level output

t_{PHL} = propagation delay time, high-to-low-level output

NOTE 3: See General Information Section for load circuits and voltage waveforms.

TYPES SN54LS137, SN74LS137 3-LINE TO 8-LINE DECODERS/DEMULPLEXERS WITH ADDRESS LATCHES

D2416, JUNE 1978—REVISED DECEMBER 1983

- Combines Decoder and 3-Bit Address Latch
- Incorporates 2 Enable Inputs to Simplify Cascading
- Low Power Dissipation . . . 65 mW Typ

description

The 'LS137 is a three-line to eight-line decoder/demultiplexer with latches on the three address inputs. When the latch-enable input (\overline{GL}) is low, the 'LS137 acts as a decoder/demultiplexer. When \overline{GL} goes from low to high, the address present at the select inputs (A, B, and C) is stored in the latches. Further address changes are ignored as long as \overline{GL} remains high. The output enable controls, G1 and $\overline{G2}$, control the state of the outputs independently of the select or latch-enable inputs. All of the outputs are high unless G1 is high and $\overline{G2}$ is low. The 'LS137 is ideally suited for implementing glitch-free decoders in strobed (stored-address) applications in bus-oriented systems.

SN54LS137 . . . J OR W PACKAGE
SN74LS137 . . . D, J OR N PACKAGE
(TOP VIEW)

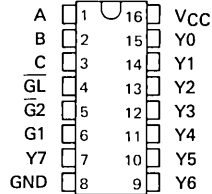

SN54LS137 . . . FK PACKAGE
SN74LS137 . . . FN PACKAGE
(TOP VIEW)

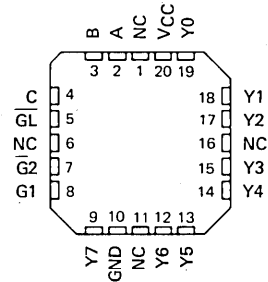

NC - No internal connection

schematics of inputs and outputs

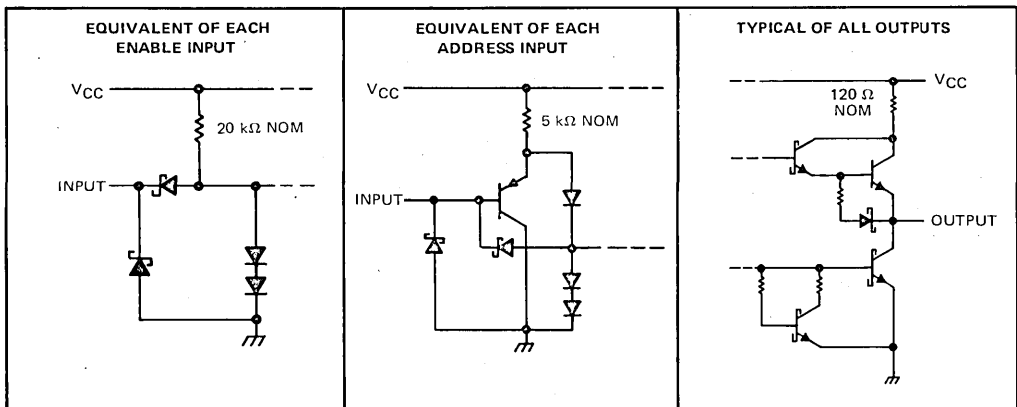

PRODUCTION DATA
This document contains information current as of publication date. Products conform to specifications per the terms of Texas Instruments standard warranty. Production processing does not necessarily include testing of all parameters.

TEXAS INSTRUMENTS
POST OFFICE BOX 225012 • DALLAS, TEXAS 75265

TTL DEVICES

TYPES SN54LS137, SN74LS137

3-LINE TO 8-LINE DECODERS/DEMULTIPLEXERS WITH ADDRESS LATCHES

logic symbols

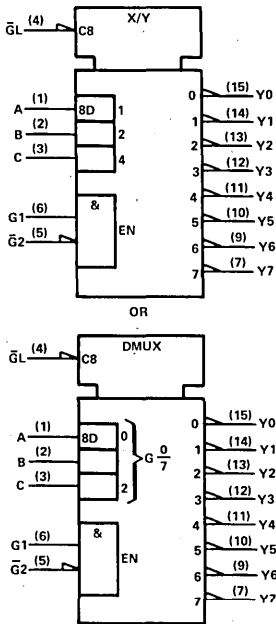

FUNCTION TABLE

INPUTS					OUTPUTS								
ENABLE			SELECT										
GL	G1	G2	C	B	A	Y0	Y1	Y2	Y3	Y4	Y5	Y6	Y7
X	X	H	X	X	X	H	H	H	H	H	H	H	H
X	L	X	X	X	X	H	H	H	H	H	H	H	H
L	H	L	L	L	L	L	H	H	H	H	H	H	H
L	H	L	L	L	H	H	L	H	H	H	H	H	H
L	H	L	L	H	L	H	H	L	H	H	H	H	H
L	H	L	L	H	H	H	H	H	L	H	H	H	H
L	H	L	H	L	H	H	H	H	H	L	H	H	H
L	H	L	H	H	L	H	H	H	H	H	L	H	H
L	H	L	H	H	H	H	H	H	H	H	H	L	H
L	H	L	H	H	H	H	H	H	H	H	H	H	L
H	H	L	X	X	X	Output corresponding to stored address, L; all others, H							

H = high level, L = low level, X = irrelevant

Pin numbers shown on logic notation are for D, J or N packages.

3

TTL DEVICES

TYPES SN54LS137, SN74LS137
3-LINE TO 8-LINE DECODERS/DEMULTIPLEXERS
WITH ADDRESS LATCHES

logic diagram (positive logic)

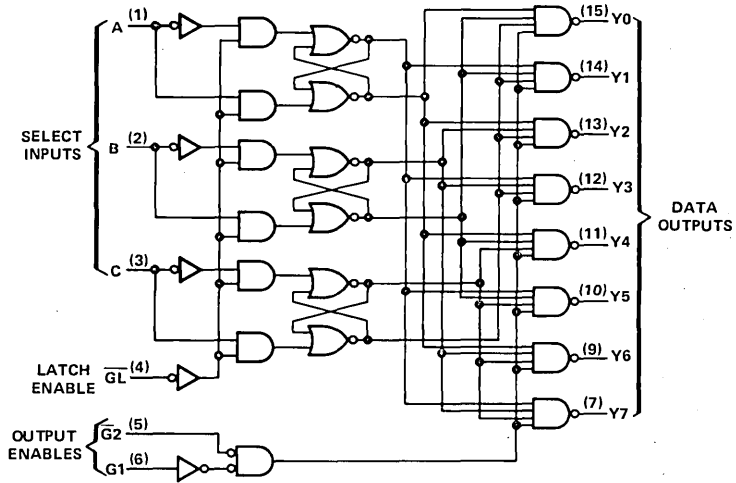

Pin numbers shown on logic notation are for D, J or N packages.

absolute maximum ratings over operating free-air temperature range (unless otherwise noted)

Supply voltage, V_{CC} (See Note 1)	7 V
Input voltage	7 V
Operating free-air temperature range: SN54LS137	-55°C to 125°C
SN74LS137	0°C to 70°C
Storage temperature range	-65°C to 150°C

NOTE 1: Voltage values are with respect to network ground terminal.



TTL DEVICES

TYPES SN54LS137, SN74LS137

3-LINE TO 8-LINE DECODERS/DEMULTIPLEXERS WITH ADDRESS LATCHES

recommended operating conditions

	SN54LS137			SN74LS137			UNIT
	MIN	NOM	MAX	MIN	NOM	MAX	
Supply voltage, V_{CC}	4.5	5	5.5	4.75	5	5.25	V
High-level output current, I_{OH}			-400			-400	μ A
Low-level output current, I_{OL}			4			8	mA
Width of enabling pulse at \bar{G}_L , t_w	15			15			ns
Setup time at A, B, and C inputs, t_{su}	10			10			ns
Hold time at A, B, and C inputs, t_h	10			10			ns
Operating free-air temperature, T_A	-55		125	0		70	$^{\circ}$ C

electrical characteristics over recommended operating free-air temperature range (unless otherwise noted)

PARAMETER	TEST CONDITIONS [†]	SN54LS137			SN74LS137			UNIT	
		MIN	TYP [‡]	MAX	MIN	TYP [‡]	MAX		
V_{IH} High-level input voltage		2			2			V	
V_{IL} Low-level input voltage				0.7			0.8	V	
V_{IK} Input clamp voltage	$V_{CC} = \text{MIN}$, $I_I = -18 \text{ mA}$			-1.5			-1.5	V	
V_{OH} High-level output voltage	$V_{CC} = \text{MIN}$, $V_{IH} = 2 \text{ V}$, $V_{IL} = V_{IL \text{ max}}$, $I_{OH} = -400 \mu\text{A}$	2.5	3.5		2.7	3.5		V	
V_{OL} Low-level output voltage	$V_{CC} = \text{MIN}$, $V_{IH} = 2 \text{ V}$, $V_{IL} = V_{IL \text{ max}}$			0.25	0.4		0.25	0.4	V
I_I Input current at maximum input voltage	$V_{CC} = \text{MAX}$, $V_I = 7 \text{ V}$			0.1			0.1	mA	
I_{IH} High-level input current	$V_{CC} = \text{MAX}$, $V_I = 2.7 \text{ V}$			20			20	μ A	
I_{IL} Low-level input current	$V_{CC} = \text{MAX}$, $V_I = 0.4 \text{ V}$			-0.4			-0.4	mA	
I_{OS} Short-circuit output current [§]	$V_{CC} = \text{MAX}$			-20	-100		-20	-100	mA
I_{CC} Supply current	$V_{CC} = \text{MAX}$, See Note 2			11	18		11	18	mA

[†] For conditions shown as MIN or MAX, use the appropriate value specified under recommended operating conditions.

[‡] All typical values are at $V_{CC} = 5 \text{ V}$, $T_A = 25^{\circ}\text{C}$.

[§] Not more than one output should be shorted at a time, and duration of the short-circuit should not exceed one second.

NOTE 2: I_{CC} is tested with all inputs grounded and all outputs open.

switching characteristics, $V_{CC} = 5 \text{ V}$, $T_A = 25^{\circ}\text{C}$, see note 3

PARAMETER [◇]	FROM (INPUT)	TO (OUTPUT)	LEVELS OF DELAY	TEST CONDITIONS	MIN	TYP	MAX	UNIT
t_{PLH}	A, B, C	Y	2	$C_L = 15 \text{ pF}$, $R_L = 2 \text{ k}\Omega$, See Note 3		11	17	ns
t_{PHL}			4		25	38		
t_{PLH}	A, B, C	Y	3		16	24	ns	
t_{PHL}			3		19	29		
t_{PLH}	Enable \bar{G}_2	Y	2		13	21	ns	
t_{PHL}			2		16	27		
t_{PLH}	Enable G1	Y	3		14	21	ns	
t_{PHL}			3		18	27		
t_{PLH}	Enable \bar{G}_L	Y	3		18	27	ns	
t_{PHL}			4		25	38		

[◇] t_{PLH} = propagation delay time, low-to-high-level output.

t_{PHL} = propagation delay time, high-to-low-level output.

NOTE 3: See General Information Section for load circuits and voltage waveforms.

TTL DEVICES

TYPES SN54LS138, SN54S138, SN74LS138, SN74S138 3-LINE TO 8-LINE DECODERS/DEMULPLEXERS

DECEMBER 1972—REVISED APRIL 1985

- **Designed Specifically for High-Speed: Memory Decoders Data Transmission Systems**
- **3 Enable Inputs to Simplify Cascading and/or Data Reception**
- **Schottky-Clamped for High Performance**

description

These Schottky-clamped TTL MSI circuits are designed to be used in high-performance memory decoding or data-routing applications requiring very short propagation delay times. In high-performance memory systems these decoders can be used to minimize the effects of system decoding. When employed with high-speed memories utilizing a fast enable circuit the delay times of these decoders and the enable time of the memory are usually less than the typical access time of the memory. This means that the effective system delay introduced by the Schottky-clamped system decoder is negligible.

The 'LS138 and 'S138 decode one of eight lines dependent on the conditions at the three binary select inputs and the three enable inputs. Two active-low and one active-high enable inputs reduce the need for external gates or inverters when expanding. A 24-line decoder can be implemented without external inverters and a 32-line decoder requires only one inverter. An enable input can be used as a data input for demultiplexing applications.

All of these decoder/demultiplexers feature fully buffered inputs, each of which represents only one normalized load to its driving circuit. All inputs are clamped with high-performance Schottky diodes to suppress line-ringing and to simplify system design.

The SN54LS138 and SN54S138 are characterized for operation over the full military temperature range of -55°C to 125°C. The SN74LS138 and SN74S138 are characterized for operation from 0°C to 70°C.

SN54LS138, SN54S138 ... J OR W PACKAGE
SN74LS138, SN74S138 ... D, J OR N PACKAGE
(TOP VIEW)

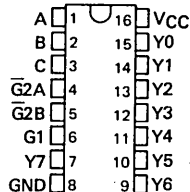

SN54LS138, SN54S138 ... FK PACKAGE
SN74LS138, SN74S138 ... FN PACKAGE
(TOP VIEW)

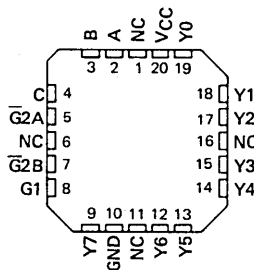

NC - No internal connection

logic symbols

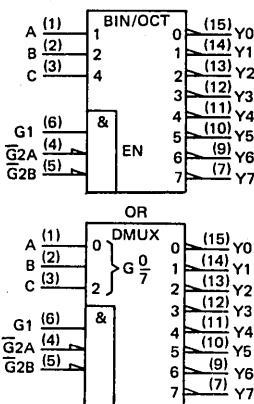

Pin numbers shown on logic notation are for D, J or N packages.

PRODUCTION DATA
This document contains information current as of publication date. Products conform to specifications per the terms of Texas Instruments standard warranty. Production processing does not necessarily include testing of all parameters.

TEXAS INSTRUMENTS

POST OFFICE BOX 225012 • DALLAS, TEXAS 75265



TYPES SN54LS138, SN54S138, SN74LS138, SN74S138
3-LINE TO 8-LINE DECODERS/DEMULTIPLEXERS

logic diagram and function table

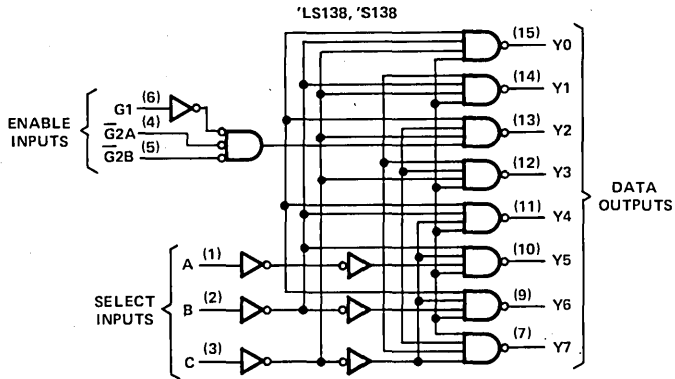

Pin numbers shown on logic notation are for D, J or N packages.

'LS138, 'S138
 FUNCTION TABLE

ENABLE		SELECT			OUTPUTS							
G1	$\bar{G}2^*$	C	B	A	Y0	Y1	Y2	Y3	Y4	Y5	Y6	Y7
X	H	X	X	X	H	H	H	H	H	H	H	H
L	X	X	X	X	H	H	H	H	H	H	H	H
H	L	L	L	L	L	H	H	H	H	H	H	H
H	L	L	L	H	H	L	H	H	H	H	H	H
H	L	L	H	L	H	H	L	H	H	H	H	H
H	L	L	H	H	H	H	H	L	H	H	H	H
H	L	H	L	L	H	H	H	H	L	H	H	H
H	L	H	L	H	H	H	H	H	L	H	H	H
H	L	H	H	L	H	H	H	H	H	L	H	H
H	L	H	H	H	H	H	H	H	H	H	L	L

* $\bar{G}2 = \bar{G}2A + \bar{G}2B$

H = high level, L = low level, X = irrelevant

3

TTL DEVICES

TYPES SN54LS138, SN54S138, SN74LS138, SN74S138
3-LINE TO 8-LINE DECODERS/DEMULTIPLEXERS

schematics of inputs and outputs

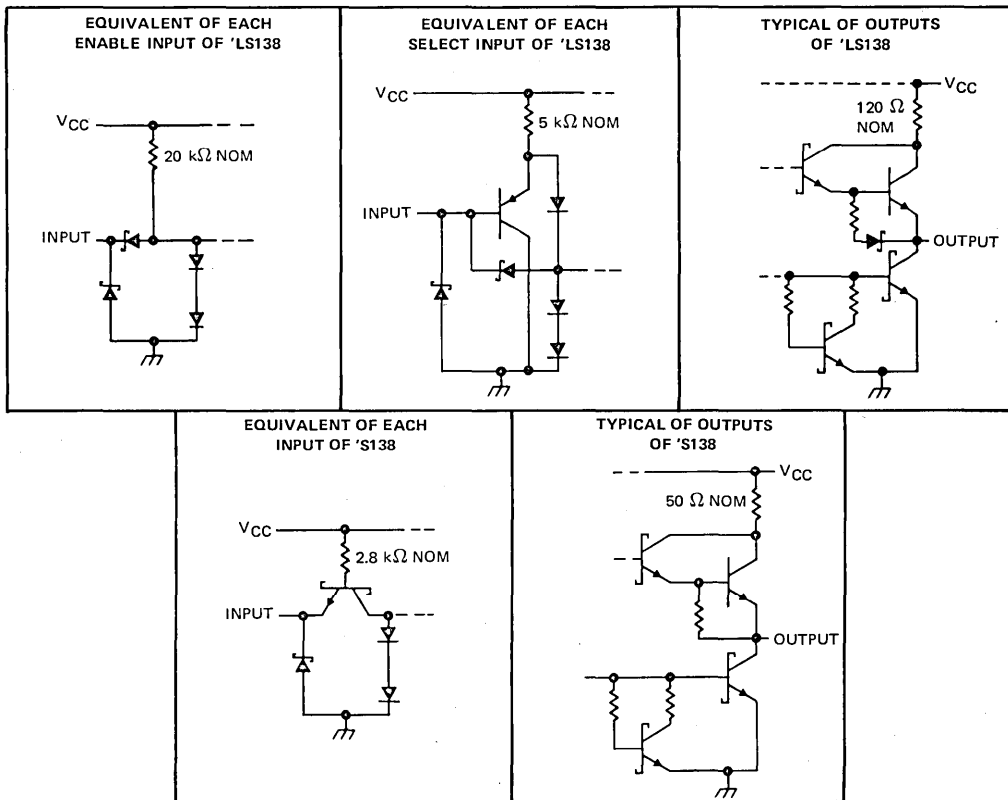

TTL DEVICES

TYPES SN54LS138, SN74LS138

3-LINE TO 8-LINE DECODERS/DEMULPLEXERS

absolute maximum ratings over operating free-air temperature range (unless otherwise noted)

Supply voltage, V_{CC} (see Note 1)	7 V
Input voltage	7 V
Operating free-air temperature range: SN54LS138	-55°C to 125°C
SN74LS138	0°C to 70°C
Storage temperature range	-65°C to 150°C

NOTE 1: Voltage values are with respect to network ground terminal.

recommended operating conditions

	SN54LS138			SN74LS138			UNIT		
	MIN	NOM	MAX	MIN	NOM	MAX			
V_{CC} Supply voltage	4.5	5	5.5	4.75	5	5.25	V		
V_{IH} High-level input voltage	2			2			V		
V_{IL} Low-level input voltage	0.7			0.8			V		
I_{OH} High-level output current	-0.4			-0.4			mA		
I_{OL} Low-level output current	4			8			mA		
T_A Operating free-air temperature	-55			125			0	70	°C

electrical characteristics over recommended operating free-air temperature range (unless otherwise noted)

PARAMETER	TEST CONDITIONS †	SN54LS138			SN74LS138			UNIT		
		MIN	TYP‡	MAX	MIN	TYP‡	MAX			
V_{IK}	$V_{CC} = \text{MIN}, I_I = -18 \text{ mA}$	-1.5			-1.5			V		
V_{OH}	$V_{CC} = \text{MIN}, V_{IH} = 2 \text{ V}, V_{IL} = \text{MAX}, I_{OH} = -0.4 \text{ mA}$	2.5	3.4		2.7	3.4		V		
V_{OL}	$V_{CC} = \text{MIN}, V_{IH} = 2 \text{ V}, V_{IL} = \text{MAX}$	$I_{OL} = 4 \text{ mA}$		0.25	0.4	0.25	0.4	V		
		$I_{OL} = 8 \text{ mA}$				0.35	0.5			
I_I	$V_{CC} = \text{MAX}, V_I = 7 \text{ V}$	0.1			0.1			mA		
I_{IH}	$V_{CC} = \text{MAX}, V_I = 2.7 \text{ V}$	20			20			µA		
I_{IL}	$V_{CC} = \text{MAX}, V_I = 0.4 \text{ V}$	Enable		-0.4		-0.4		mA		
		A, B, C		-0.2		-0.2				
$I_{OS} §$	$V_{CC} = \text{MAX}$	-20	-100		-20	-100		mA		
I_{CC}	$V_{CC} = \text{MAX},$ Outputs enabled and open	6.3			10			6.3	10	mA

† For conditions shown as MIN or MAX, use the appropriate value specified under recommended operating conditions.

‡ All typical values are at $V_{CC} = 5 \text{ V}, T_A = 25^\circ\text{C}$.

§ Not more than one output should be shorted at a time.

switching characteristics, $V_{CC} = 5 \text{ V}, T_A = 25^\circ\text{C}$

PARAMETER †	FROM (INPUT)	TO (OUTPUT)	LEVELS OF DELAY	TEST CONDITIONS	SN54LS138 SN74LS138			UNIT
					MIN	TYP	MAX	
t_{PLH}	Binary Select	Any	2	$R_L = 2 \text{ k}\Omega, C_L = 15 \text{ pF},$ See Note 2	11		20	ns
t_{PHL}					18		41	ns
t_{PLH}			21		27	ns		
t_{PHL}			20		39	ns		
t_{PLH}	Enable	Any	2		12		18	ns
t_{PHL}					20		32	ns
t_{PLH}			14		26	ns		
t_{PHL}			13		38	ns		

† t_{PLH} = propagation delay time, low-to-high-level output; t_{PHL} = propagation delay time, high-to-low-level output.

NOTE 2: See General Information Section for load circuits and voltage waveforms.

3

TTL DEVICES

TYPES SN54S138, SN74S138 3-LINE TO 8-LINE DECODERS/DEMULTIPLEXERS

absolute maximum ratings over operating free-air temperature range (unless otherwise noted)

Supply voltage, V_{CC} (see Note 1)	7 V
Input voltage	5.5 V
Operating free-air temperature range: SN54S138	- 55° C to 125° C
SN74S138	0° C to 70° C
Storage temperature range	- 65° C to 150° C

NOTE 1: Voltage values are with respect to network ground terminal.

recommended operating conditions

	SN54S138			SN74S138			UNIT
	MIN	NOM	MAX	MIN	NOM	MAX	
V_{CC} Supply voltage	4.5	5	5.5	4.75	5	5.25	V
V_{IH} High-level input voltage	2			2			V
V_{IL} Low-level input voltage			0.8			0.8	V
I_{OH} High-level output current			- 1			- 1	mA
I_{OL} Low-level output current			20			20	mA
T_A Operating free-air temperature	- 55		125	0		70	°C

electrical characteristics over recommended operating free-air temperature range (unless otherwise noted)

PARAMETER	TEST CONDITIONS†		SN54S138 SN74S138		UNIT
			MIN	TYP‡	
V_{IK}	$V_{CC} = \text{MIN}, I_I = 18 \text{ mA}$		- 1.2		V
V_{OH}	$V_{CC} = \text{MIN}, V_{IH} = 2 \text{ V}, V_{IL} = 0.8 \text{ V}, I_{OH} = - 1 \text{ mA}$	SN54S'	2.5	3.4	V
		SN74S'	2.7	3.4	
V_{OL}	$V_{CC} = \text{MIN}, V_{IH} = 2 \text{ V}, V_{IL} = 0.8 \text{ V}, I_{OL} = 20 \text{ mA}$		0.5		V
I_I	$V_{CC} = \text{MAX}, V_I = 5.5 \text{ V}$		1		mA
I_{IH}	$V_{CC} = \text{MAX}, V_I = 2.7 \text{ V}$		50		µA
I_{IL}	$V_{CC} = \text{MAX}, V_I = 0.5 \text{ V}$		- 2		mA
I_{OS}^{\S}	$V_{CC} = \text{MAX}$		- 40	- 100	mA
I_{CC}	$V_{CC} = \text{MAX},$ Outputs enabled and open	SN54S'	60	74	mA
		SN74S'	75	90	

†For conditions shown as MIN or MAX, use the appropriate value specified under recommended operating conditions.

‡All typical values are at $V_{CC} = 5 \text{ V}, T_A = 25^\circ \text{C}$.

§Not more than one output should be shorted at a time, and duration of the short circuit test should not exceed one second.

switching characteristics, $V_{CC} = 5 \text{ V}, T_A = 25^\circ \text{C}$

PARAMETER†	FROM (INPUT)	TO (OUTPUT)	LEVELS OF DELAY	TEST CONDITIONS	SN54S138 SN74S138			UNIT
					MIN	TYP	MAX	
t_{PLH}	Binary Select	Any	2	$R_L = 280 \Omega, C_L = 15 \text{ pF},$ See Note 2	4.5	7	ns	
t_{PHL}					7	10.5		
t_{PLH}			3		7.5	12	ns	
t_{PHL}					8	12		
t_{PLH}	Enable	Any	2		5	8	ns	
t_{PHL}					7	11		
t_{PLH}			3		7	11	ns	
t_{PHL}					7	11		

† t_{PLH} = propagation delay time, low-to-high-level output

t_{PHL} = propagation delay time, high-to-low-level output

NOTE 2: See General Information Section for load circuits and voltage waveforms.

3
TTL DEVICES

TYPES SN54LS139A, SN54S139, SN74LS139A, SN74S139 DUAL 2-LINE TO 4-LINE DECODERS/DEMULPLEXERS

REVISED APRIL 1985

- **Designed Specifically for High-Speed: Memory Decoders Data Transmission Systems**
- **Two Fully Independent 2-to-4-Line Decoders/Demultiplexers**
- **Schottky Clamped for High Performance**

SN54LS139A, SN54S139 ... J OR W PACKAGE
SN74LS139A, SN74S139 ... D, J OR N PACKAGE

(TOP VIEW)

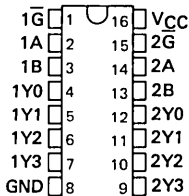

SN54LS139A, SN54S139 ... FK PACKAGE
SN74LS139A, SN74S139 ... FN PACKAGE

(TOP VIEW)

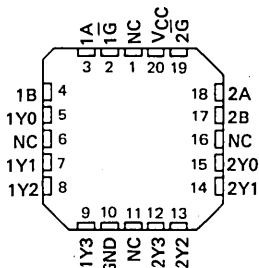

NC - No internal connection

description

These Schottky-clamped TTL MSI circuits are designed to be used in high-performance memory decoding or data-routing applications requiring very short propagation delay times. In high-performance memory systems these decoders can be used to minimize the effects of system decoding. When employed with high-speed memories utilizing a fast enable circuit the delay times of these decoders and the enable time of the memory are usually less than the typical access time of the memory. This means that the effective system delay introduced by the Schottky-clamped system decoder is negligible.

The circuit comprises two individual two-line to four-line decoders in a single package. The active-low enable input can be used as a data line in demultiplexing applications.

All of these decoders/demultiplexers feature fully buffered inputs, each of which represents only one normalized load to its driving circuit. All inputs are clamped with high-performance Schottky diodes to suppress line-ringing and to simplify system design. The SN54LS139A and SN54S139 are characterized for operation range of -55°C to 125°C . The SN74LS139A and SN74S139 are characterized for operation from 0°C to 70°C .

logic diagram

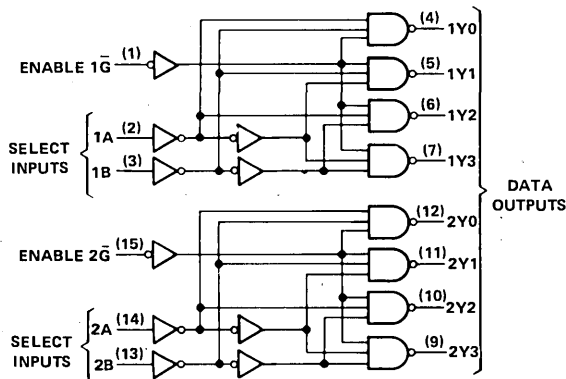

Pin numbers shown on logic notation are for D, J or N packages.

FUNCTION TABLE

ENABLE	SELECT		OUTPUTS			
	\bar{G}	B A	Y0	Y1	Y2	Y3
H	X	X	H	H	H	H
L	L	L	L	H	H	H
L	L	H	H	L	H	H
L	H	L	H	H	L	H
L	H	H	H	H	L	L

H = high level, L = low level, X = irrelevant

TYPES SN54LS139A, SN54S139, SN74LS139A, SN74S139 DUAL 2-LINE TO 4-LINE DECODERS/DEMULTIPLEXERS

schematics of inputs and outputs

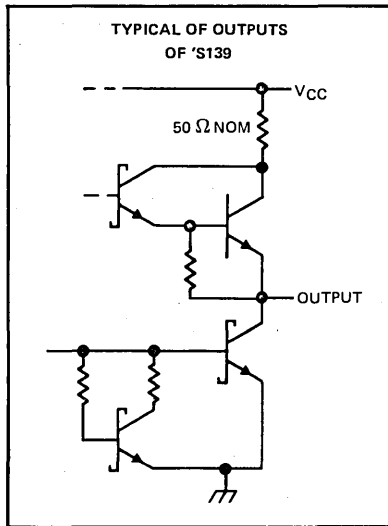
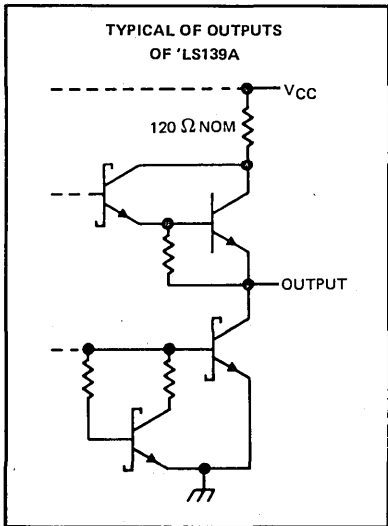
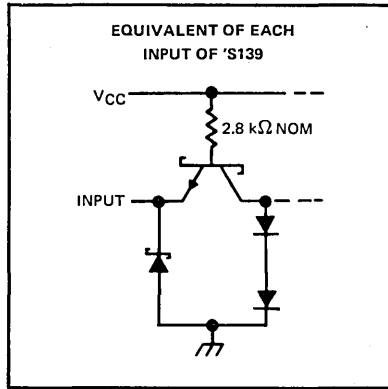
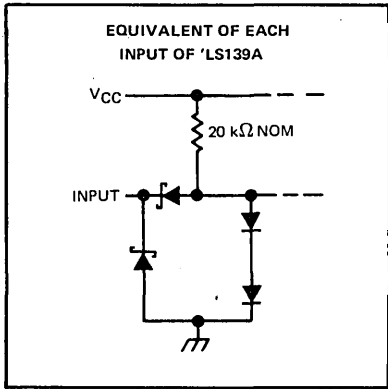

absolute maximum ratings over operating free-air temperature range (unless otherwise noted)

Supply voltage, V_{CC} (see Note 1)	7 V
Input voltage: 'LS139A, 'LS139	7 V
'S139	5.5 V
Operating free-air temperature range: SN54LS139A, SN54S139	-55°C to 125°C
SN74LS139A, SN54S139	0°C to 70°C
Storage temperature range	-65°C to 150°C

NOTE 1: Voltage values are with respect to network ground terminal.

3
TTL DEVICES

TYPES SN54LS139A, SN74LS139A DUAL 2-LINE TO 4-LINE DECODERS/DEMULTIPLEXERS

recommended operating conditions

		SN54LS139A			SN74LS139A			UNIT
		MIN	NOM	MAX	MIN	NOM	MAX	
V _{CC}	Supply voltage	4.5	5	5.5	4.75	5	5.25	V
V _{IH}	High-level input voltage	2			2			V
V _{IL}	Low-level input voltage	0.7			0.8			V
I _{OH}	High-level output current	-0.4			-0.4			mA
I _{OL}	Low-level output current	4			8			mA
T _A	Operating free-air temperature	-55			125			°C

electrical characteristics over recommended operating free-air temperature range (unless otherwise noted)

PARAMETER	TEST CONDITIONS †	SN54LS139A			SN74LS139A			UNIT
		MIN	TYP ‡	MAX	MIN	TYP ‡	MAX	
V _{IK}	V _{CC} = MIN, I _I = -18 mA	-1.5			-1.5			V
V _{OH}	V _{CC} = MIN, V _{IH} = 2 V, V _{IL} = MAX, I _{OH} = -0.4 mA	2.5	3.4		2.7	3.4		V
V _{OL}	V _{CC} = MIN, V _{IH} = 2 V, V _{IL} = MAX	I _{OL} = 4 mA			0.25	0.4		V
		I _{OL} = 8 mA			0.35 0.5			
I _I	V _{CC} = MAX, V _I = 7 V	0.1			0.1			mA
I _{IH}	V _{CC} = MAX, V _I = 2.7 V	20			20			μA
I _{IL}	V _{CC} = MAX, V _I = 0.4 V	-0.4			-0.4			mA
I _{OS} §	V _{CC} = MAX	-20	-100		-20	-100		mA
I _{CC}	V _{CC} = MAX, Outputs enabled and open	6.8 11			6.8 11			mA

switching characteristics, V_{CC} = 5 V, T_A = 25°C (see note 2)

PARAMETER †	FROM (INPUT)	TO (OUTPUT)	LEVELS OF DELAY	TEST CONDITIONS	SN54LS139A		UNIT
					MIN	MAX	
t _{PLH}	Binary Select	Any	2	R _L = 2 kΩ, C _L = 15 pF	13	20	ns
t _{PHL}					22	33	ns
t _{PLH}			18		29	ns	
t _{PHL}	25	38	ns				
t _{PLH}	Enable	Any	2		16	24	ns
t _{PHL}					21	32	ns

† t_{PLH} = propagation delay time, low to high level output; t_{PHL} = propagation delay time, high-to-low-level output.
NOTE 2: See General Information Section for load circuits and voltage waveforms.

TYPES SN54S139, SN74S139 DUAL 2-LINE TO 4-LINE DECODERS/DEMULTIPLEXERS

recommended operating conditions

	SN54S139			SN74S139			UNIT	
	MIN	NOM	MAX	MIN	NOM	MAX		
V _{CC} Supply voltage	4.5	5	5.5	4.75	5	5.25	V	
V _{IH} High-level input voltage	2			2			V	
V _{IL} Low-level input voltage	0.8			0.8			V	
I _{OH} High-level output current	-1			-1			mA	
I _{OL} Low-level output current	20			20			mA	
T _A Operating free-air temperature	-55			0			70	°C

electrical characteristics over recommended operating free-air temperature range (unless otherwise noted)

PARAMETER	TEST CONDITIONS†	SN54S139 SN74S138			UNIT	
		MIN	TYP‡	MAX		
V _{IK}	V _{CC} = MIN, I _I = 18 mA	-1.2			V	
V _{OH}	V _{CC} = MIN, V _{IH} = 2 V, V _{IL} = 0.8 V, I _{OH} = -1 mA	SN54S'	2.5	3.4	V	
		SN74S'	2.7	3.4		
V _{OL}	V _{CC} = MIN, V _{IH} = 2 V, V _{IL} = 0.8 V, I _{OL} = 20 mA	0.5			V	
I _I	V _{CC} = MAX, V _I = 5.5 V	1			mA	
I _{IH}	V _{CC} = MAX, V _I = 2.7 V	50			µA	
I _{IL}	V _{CC} = MAX, V _I = 0.5 V	-2			mA	
I _{OS} §	V _{CC} = MAX	-40			-100	mA
I _{CC}	V _{CC} = MAX, Outputs enabled and open	SN54S'	60	74	mA	
		SN74S'	75	90		

†For conditions shown as MIN or MAX, use the appropriate value specified under recommended operating conditions.

‡All typical values are at V_{CC} = 5 V, T_A = 25°C.

§Not more than one output should be shorted at a time, and duration of the short circuit test should not exceed one second.

switching characteristics, V_{CC} = 5 V, T_A = 25°C (see note 2)

PARAMETER†	FROM (INPUT)	TO (OUTPUT)	LEVELS OF DELAY	TEST CONDITIONS	SN54S139 SN74S139			UNIT
					MIN	TYP	MAX	
t _{PLH}	Binary Select	Any	2	R _L = 280 Ω, C _L = 15 pF	5	7.5	ns	
t _{PHL}					6.5	10	ns	
t _{PLH}	3	7	12		ns			
t _{PHL}		8	12		ns			
t _{PLH}	Enable	Any	2		5	8	ns	
t _{PHL}					6.5	10	ns	

† t_{PLH} = propagation delay time, low to high-level output

t_{PHL} = propagation delay time, high to low-level output

NOTE 2: See General Information Section for load circuits and voltage waveforms.

TTL DEVICES

TYPES SN54S140, SN74S140 DUAL 4-INPUT POSITIVE-NAND 50-OHM LINE DRIVERS

REVISED DECEMBER 1983

- Package Options Include Both Plastic and Ceramic Chip Carriers in Addition to Plastic and Ceramic DIPs
- Dependable Texas Instruments Quality and Reliability

description

These devices contain two independent 4-input positive-NAND 50-ohm line drivers. They perform the Boolean function $Y = \overline{ABCD}$.

The SN54S140 is characterized for operation over the full military temperature range of -55°C to 125°C . The SN74S140 is characterized for operation from 0°C to 70°C .

logic diagram (each driver)



SN54S140 ... J OR W PACKAGE
SN74S140 ... D, J OR N PACKAGE
(TOP VIEW)

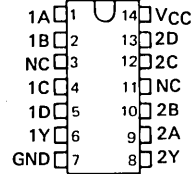

SN54S140 ... FK PACKAGE
SN74S140 ... FN PACKAGE
(TOP VIEW)

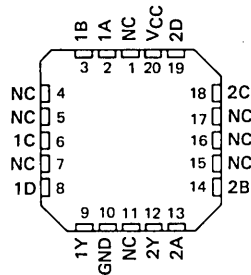

NC - No internal connection

3

TTL DEVICES

PRODUCTION DATA

This document contains information current as of publication date. Products conform to specifications per the terms of Texas Instruments standard warranty. Production processing does not necessarily include testing of all parameters.

TEXAS
INSTRUMENTS

POST OFFICE BOX 225012 • DALLAS, TEXAS 75265

TYPES SN54S140, SN74S140
DUAL 4-INPUT POSITIVE-NAND 50-OHM LINE DRIVERS

schematic (each driver)

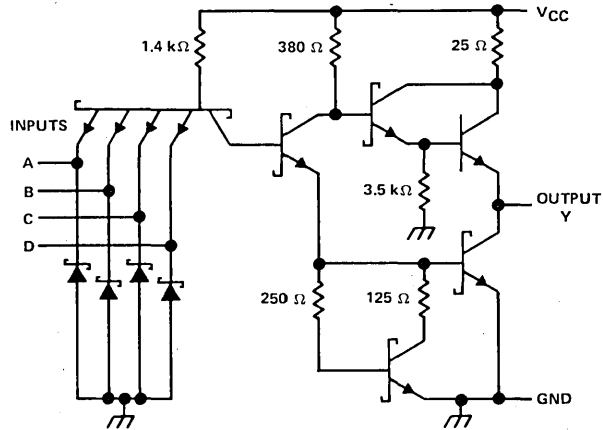

Resistor values shown are nominal.

absolute maximum ratings over operating free-air temperature range (unless otherwise noted)

Supply voltage, V_{CC} (see Note 1)	7 V
Input voltage	5.5 V
Operating free-air temperature range: SN54'	-55°C to 125°C
SN74'	0°C to 70°C
Storage temperature range	-65°C to 150°C

NOTE 1: Voltage values are with respect to network ground terminal.

3

TTL DEVICES

TYPES SN54S140, SN74S140 DUAL 4-INPUT POSITIVE-NAND 50-OHM LINE DRIVERS

recommended operating conditions

	SN54S140			SN74S140			UNIT
	MIN	NOM	MAX	MIN	NOM	MAX	
V _{CC} Supply voltage	4.5	5	5.5	4.75	5	5.25	V
V _{IH} High-level input voltage	2			2			V
V _{IL} Low-level input voltage			0.8			0.8	V
I _{OH} High-level output current			-40			-40	mA
I _{OL} Low-level output current			60			60	mA
T _A Operating free-air temperature	-55		125	0		70	°C

electrical characteristics over recommended operating free-air temperature range (unless otherwise noted)

PARAMETER	TEST CONDITIONS†	SN54S140		SN74S140		UNIT
		MIN	TYP‡	MAX	MIN	
V _{IK}	V _{CC} = MIN, I _I = -18 mA		-1.2		-1.2	V
V _{OH}	V _{CC} = MIN, V _{IL} = 0.8 V, I _{OH} = -3 mA	2.5	3.4	2.7	3.4	V
	V _{CC} = MIN, V _{IL} = 0.5 V, R _O = 50 Ω to GND	2		2		
V _{OL}	V _{CC} = MIN, V _{IH} = 2 V, I _{OL} = 60 mA		0.5		0.5	V
I _I	V _{CC} = MAX, V _I = 5.5 V		1		1	mA
I _{IH}	V _{CC} = MAX, V _{IH} = 2.7 V		0.1		0.1	mA
I _{IL}	V _{CC} = MAX, V _{IL} = 0.5 V		-4		-4	mA
I _{OS} §	V _{CC} = MAX	-50		-50		mA
I _{CCH}	V _{CC} = MAX, V _I = 0 V		10		10	mA
I _{CCL}	V _{CC} = MAX, V _I = 4.5 V		25		25	mA

† For conditions shown as MIN or MAX, use the appropriate value specified under recommended operating conditions.

‡ All typical values are at V_{CC} = 5 V, T_A = 25°C.

§ Not more than one output should be shorted at a time, and the duration of the short circuit should not exceed 100 milliseconds.

switching characteristics, V_{CC} = 5 V, T_A = 25°C (see note 2)

PARAMETER	FROM (INPUT)	TO (OUTPUT)	TEST CONDITIONS		MIN	TYP	MAX	UNIT
t _{PLH}	Any	Y	R _L = 93 Ω,	C _L = 50 pF	4	6.5	ns	
t _{PHL}						4		6.5
t _{PLH}			R _L = 93 Ω,	C _L = 150 pF	6	ns		
t _{PHL}							6	ns

NOTE 2: See General Information Section for load circuits and voltage waveforms.

3

TTL DEVICES

TYPE SN74141 BCD-TO-DECIMAL DECODER/DRIVER

DECEMBER 1972—REVISED DECEMBER 1983

- Drives Gas-filled Cold-cathode Indicator Tubes Directly
- Fully Decoded Inputs Ensure all Outputs are Off for Invalid Codes
- Input Clamping Diodes Minimize Transmission-line Effects

description

The SN74141 is a second-generation BCD-to-decimal decoder designed specifically to drive cold-cathode indicator tubes. This decoder demonstrates an improved capability to minimize switching transients in order to maintain a stable display.

Full decoding is provided for all possible input states. For binary inputs 10 through 15, all the outputs are off. Therefore the SN74141, combined with a minimum of external circuitry, can use these invalid codes in blanking leading- and/or trailing-edge zeros in a display. The ten high-performance, n-p-n output transistors have a maximum reverse current of 50 microamperes at 55 volts.

Low-forward-impedance diodes are also provided for each input to clamp negative-voltage transitions in order to minimize transmission-line effects. Power dissipation is typically 80 milliwatts. The SN74141 is characterized for operation over the temperature range of 0°C to 70°C.

FUNCTION TABLE

INPUT				OUTPUT
D	C	B	A	ON†
L	L	L	L	0
L	L	L	H	1
L	L	H	L	2
L	L	H	H	3
L	H	L	L	4
L	H	L	H	5
L	H	H	L	6
L	H	H	H	7
H	L	L	L	8
H	L	L	H	9
H	L	H	L	NONE
H	L	H	H	NONE
H	H	L	L	NONE
H	H	L	H	NONE
H	H	H	L	NONE
H	H	H	H	NONE

H = high level, L = low level
† All other outputs are off

JORN PACKAGE
(TOP VIEW)

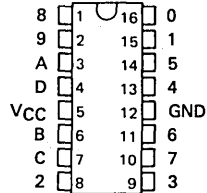

logic diagram

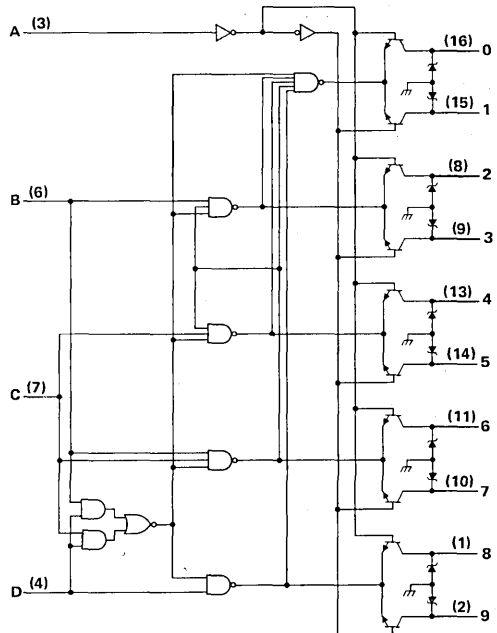

3

TTL DEVICES

PRODUCTION DATA

This document contains information current as of publication date. Products conform to specifications per the terms of Texas Instruments standard warranty. Production processing does not necessarily include testing of all parameters.

TEXAS
INSTRUMENTS

POST OFFICE BOX 225012 • DALLAS, TEXAS 75265

3-539

TYPE SN74141 BCD-TO-DECIMAL DECODER/DRIVER

absolute maximum ratings over operating free-air temperature range (unless otherwise noted)

Supply voltage, V_{CC} (see Note 1)	7 V
Input voltage	5.5 V
Current into any output (off-state)	2 mA
Operating free-air temperature range	0°C to 70°C
Storage temperature range	-65°C to 150°C

NOTE 1: Voltage values are with respect to network ground terminal.

recommended operating conditions

	MIN	NOM	MAX	UNIT
Supply voltage, V_{CC}	4.75	5	5.25	V
Off-state output voltage			60	V
Operating free-air temperature, T_A	0		70	°C

electrical characteristics over recommended operating free-air temperature range (unless otherwise noted)

PARAMETER		TEST CONDITIONS†	MIN	TYP‡	MAX	UNIT
V_{IH}	High-level input voltage		2			V
V_{IL}	Low-level input voltage				0.8	V
V_{IK}	Input clamp voltage	$V_{CC} = \text{MIN}, I_I = -5 \text{ mA}$			-1.5	V
$V_{O(\text{on})}$	On-state output voltage	$V_{CC} = \text{MIN}, I_O = 7 \text{ mA}$			2.5	V
$V_{O(\text{off})}$	Off-state output voltage for input counts 0 thru 9	$V_{CC} = \text{MAX}, I_O = 0.5 \text{ mA}$	60			V
$I_{O(\text{off})}$	Off-state reverse current	$V_{CC} = \text{MAX}, V_O = 55 \text{ V}$			50	μA
$I_{O(\text{off})}$	Off-state reverse current for input counts 10 thru 15	$V_{CC} = \text{MAX}, V_O = 30 \text{ V}$			5	μA
I_I	Input current at maximum input voltage	$V_{CC} = \text{MAX}, V_I = 5.5 \text{ V}$			15	μA
I_{IH}	High-level input current	A input			40	μA
		B, C, or D input	$V_{CC} = \text{MAX}, V_I = 2.4 \text{ V}$		80	μA
I_{IL}	Low-level input current	A input	$V_{CC} = \text{MAX}, V_I = 0.4 \text{ V}$		-1.6	mA
		B, C, or D input			-3.2	mA
I_{CC}	Supply current	$V_{CC} = \text{MAX}$, See Note 2		16	25	mA

†For conditions shown as MIN or MAX, use the appropriate value specified under recommended operating conditions.

‡This typical value is at $V_{CC} = 5 \text{ V}, T_A = 25^\circ\text{C}$.

NOTE 2: I_{CC} is measured with all inputs grounded and outputs open.

schematics of inputs and outputs

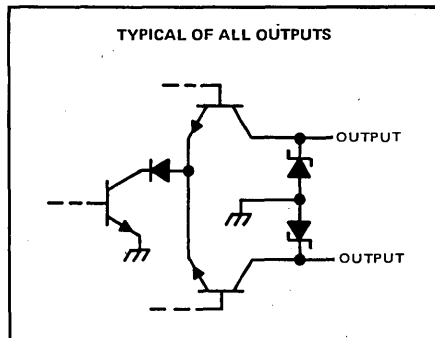
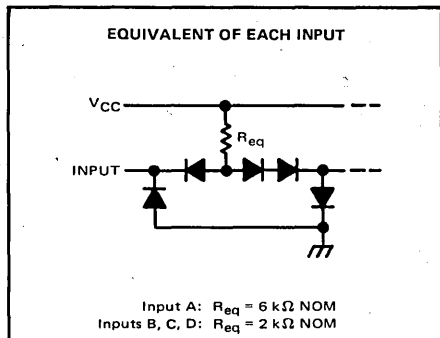

TYPE SN74142 BCD COUNTER/4-BIT LATCH/BCD DECODER/DRIVER

BULLETIN NO. DL-S 7211719, MAY 1972—REVISED DECEMBER 1972

FUNCTION TABLE

INPUTS			OUTPUTS	
COUNT PULSE (CLOCK)	CLEAR	LATCH STROBE	ON [†]	\bar{Q}_D
X	L	L	0	H
1	H	L	1	H
2	H	L	2	H
3	H	L	3	H
4	H	L	4	H
5	H	L	5	H
6	H	L	6	H
7	H	L	7	H
8	H	L	8	L
9	H	L	9	L
10	H	L	0	H
11	H	H	0	H

[†]All other outputs are off.

H = high level, L = low level, X = irrelevant

SN74142 . . . J OR N PACKAGE
(TOP VIEW)

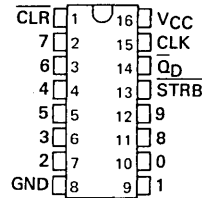

description

The SN74142 contains a divide-by-ten (BCD) counter, a four-bit latch, and a decoder/*Nixie*[‡] tube driver on a monolithic chip and is packaged in popular 16-pin packages. This single MSI function can replace the equivalent of three separately packaged MSI circuits to reduce printed-circuit board area and the number of system interconnections, resulting in reduced costs and improved reliability.

Four master-slave flip-flops are fully decoded to provide a divide-by-ten counter. A direct clear input will, when taken low, reset and hold the counter at zero (all Q outputs low, \bar{Q}_D output high). While the clear input is inactive (high), each positive-going transition of the clock will increment the counter. The \bar{Q}_D output is made available externally for cascading to n-bit counters.

The Q outputs of the counter are routed to the data inputs of the four-bit latch. While the latch strobe input is low, the internal latch outputs will follow the respective Q outputs of the counter. When the latch strobe input is taken high, the latch stores the data which has been setup by the counter outputs prior to the low-to-high level transition of the latch strobe input. The \bar{Q}_D output from the counter is not stored by the latch since it is intended for clocking the next counter stage. This means that the system counter can continuously acquire new data. Since all outputs of the latch and Q outputs of the counter drive low-capacitance on-chip loads, the circuitry is considerably simplified with respect to the number of components required. This results in a highly efficient function which typically reduces power requirements 15% when compared to systems using the three separate packages.

The SN74142 counter/latch/driver features fully buffered inputs to reduce drive requirements to one normalized Series 74 load per input, and diode-clamping of all inputs to minimize transmission line effects. The counter will accept input clock frequencies up to 20 MHz and is entirely compatible for use with all popular TTL and DTL logic circuits. The high-performance n-p-n driver outputs are identical to the SN74141 and have a maximum off-state reverse current of 50 microamperes at 55 volts.

[‡]*Nixie* is a registered trademark of the Burroughs Corporation.

PRODUCTION DATA

This document contains information current as of publication date. Products conform to specifications per the terms of Texas Instruments standard warranty. Production processing does not necessarily include testing of all parameters.

**TEXAS
INSTRUMENTS**

POST OFFICE BOX 225012 • DALLAS, TEXAS 75265

3

TTL DEVICES

TYPES SN74142

BCD COUNTER/4-BIT LATCH/BCD DECODER/DRIVER

absolute maximum ratings over operating free-air temperature range (unless otherwise noted)

Supply voltage, V_{CC} (see Note 1)	7 V
Input voltage	5.5 V
Off-state current into outputs 0 thru 9	1 mA
Operating free-air temperature range	0°C to 70°C
Storage temperature range	-65°C to 150°C

NOTE 1: All voltage values are with respect to the network ground terminal.

recommended operating conditions

	MIN	NOM	MAX	UNIT
Supply voltage, V_{CC}	4.75	5	5.25	V
High-level output current from \bar{Q}_D , I_{OH}			-400	μ A
Low-level output current from \bar{Q}_D , I_{OL}			8	mA
Input clock frequency, f_{clock}	0		20	MHz
Clock pulse width, $t_{w(clock)}$ (see Figure 1)	High logic level	15		ns
	Low logic level	35		
Clear pulse width, $t_{w(clear)}$ (see Figure 1)	25			ns
Strobe pulse width, $t_{w(strobe)}$ (see Figure 1)	20			ns
Clear inactive-state setup time, t_{su} (see Figure 1)	25			ns
Strobe time, t_{strobe} (see Figure 1)	45		$t_{w(clock)} + 10$	ns
Operating free-air temperature, T_A	0		70	°C

electrical characteristics over recommended operating free-air temperature range (unless otherwise noted)

PARAMETER	TEST CONDITIONS†	MIN	TYP‡	MAX	UNIT
V_{IH} High-level input voltage		2			V
V_{IL} Low-level input voltage				0.8	V
V_{IK} Input clamp voltage	$V_{CC} = \text{MIN}$, $I_I = -12 \text{ mA}$			-1.5	V
V_{OH} High-level \bar{Q}_D output voltage	$V_{CC} = \text{MIN}$, $I_{OH} = -400 \mu\text{A}$	2.4	3.4		V
V_{OL} Low-level \bar{Q}_D output voltage	$V_{CC} = \text{MIN}$, $I_{OL} = 8 \text{ mA}$		0.2	0.4	V
$V_{O(on)}$ On-state voltage, outputs 0 thru 9	$V_{CC} = \text{MIN}$, $I_O = 7 \text{ mA}$			2.5	V
$V_{O(off)}$ Off-state voltage, outputs 0 thru 9	$V_{CC} = \text{MAX}$, $I_O = 0.5 \text{ mA}$	60			V
$I_{O(off)}$ Off-state current, outputs 0 thru 9	$V_{CC} = \text{MAX}$, $V_O = 55 \text{ V}$			50	μ A
I_I Input current at maximum input voltage	$V_{CC} = \text{MAX}$, $V_I = 5.5 \text{ V}$			1	mA
I_{IH} High-level input current	$V_{CC} = \text{MAX}$, $V_I = 2.4 \text{ V}$			40	μ A
I_{IL} Low-level input current	$V_{CC} = \text{MAX}$, $V_I = 0.4 \text{ V}$			-1.6	mA
I_{OS} Short-circuit \bar{Q}_D output current	$V_{CC} = \text{MAX}$	-18		-55	mA
I_{CC} Supply current	$V_{CC} = \text{MAX}$, All outputs open		68	102	mA

† For conditions shown as MIN or MAX, use the appropriate value specified under recommended operating conditions.

‡ All typical values are at $V_{CC} = 5 \text{ V}$, $T_A = 25^\circ\text{C}$.

switching characteristics, $V_{CC} = 5 \text{ V}$, $T_A = 25^\circ\text{C}$

PARAMETER	TEST CONDITIONS	MIN	TYP	MAX	UNIT
t_{PLH} Propagation delay time, low-to-high-level \bar{Q}_D output from clock	$C_L = 15 \text{ pF}$, $R_L = 800 \Omega$, See Figure 1		35	55	ns
t_{PHL} Propagation delay time, high-to-low-level \bar{Q}_D output from clock			30	45	
t_{PLH} Propagation delay time, low-to-high-level \bar{Q}_D output from clear				.30	45

schematics of inputs and outputs

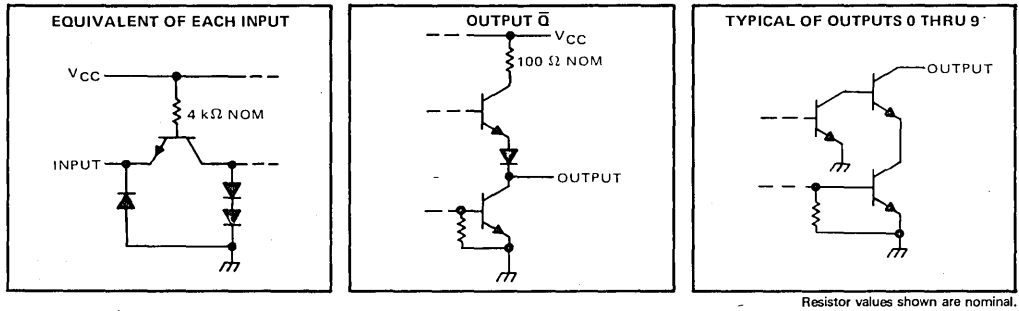

Resistor values shown are nominal.

PARAMETER MEASUREMENT INFORMATION

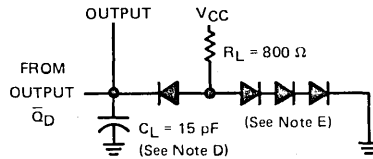

LOAD CIRCUIT

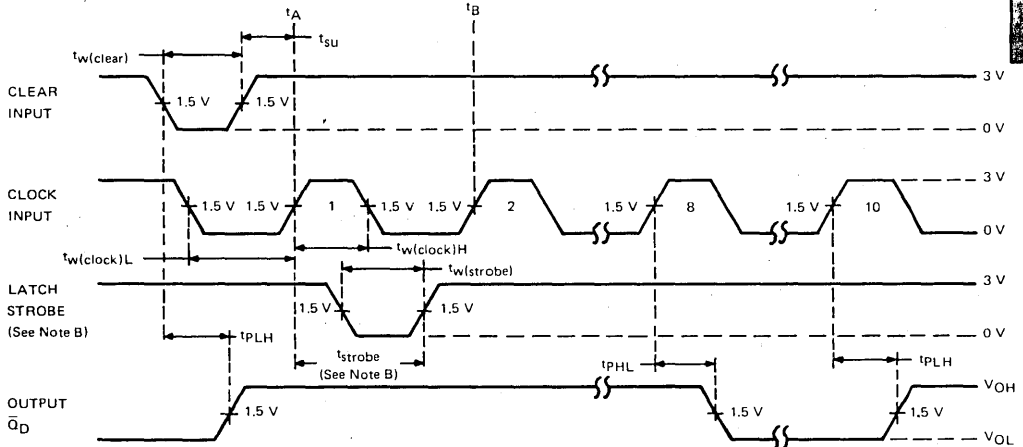

VOLTAGE WAVEFORMS

- NOTES: A. This typical abbreviated sequence illustrates clearing from count 8 or 9 and counting through ten clock pulses. Clock pulses 3 through 7 and 9 are omitted for brevity.
- B. Strobe input can go low at any time; however, the positive transition to store data from any given clock transition (t_A) must occur a minimum of 45 ns after t_A and prior to 10 ns after the next positive-going clock transition ($t_B + 10$ ns).
- C. Input pulses are supplied by generators having the following characteristics: $t_r \leq 7$ ns, $t_f \leq 7$ ns, PRR = 1 MHz, and $Z_{out} \approx 50 \Omega$.
- D. C_L includes probe and jig capacitance.
- E. All diodes are 1N3064 or equivalent.

FIGURE 1



TTL DEVICES



TTL DEVICES

TYPES SN54143, SN54144, SN74143, SN74144 4-BIT COUNTER/LATCH, SEVEN-SEGMENT LED/LAMP DRIVERS

NOVEMBER 1971—REVISED DECEMBER 1983

- **Choice of Driver Outputs:**

SN54143 and SN74143 have 15 mA Constant-Current Outputs for Driving Common-Anode LED's such as TIL302 or TIL303 without Series Resistors

SN54144 and SN74144 Drive High-Current Lamps, Numitrons[†], or LED's from Saturated Open-Collector Outputs

- **Universal Logic Capabilities**

Ripple Blanking of Extraneous Zeros
Latch Outputs Can Drive Logic Processors Simultaneously

Decimal Point Driver Is Included

- **Synchronous BCD Counter Capability Includes:**

Cascadable to N-Bits

Look-Ahead-Enable Techniques Minimize Speed Degradation When Cascaded for Large-Word Display

Direct Clear Input

SN54143, SN54144 . . . J OR W PACKAGE

SN74143, SN74144 . . . J OR N PACKAGE

(TOP VIEW)

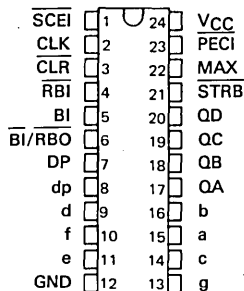

description

These TTL MSI circuits contain the equivalent of 86 gates on a single chip. Logic inputs and outputs are completely TTL compatible. The buffered inputs are implemented with relatively large resistors in series with the bases of the input transistors to lower drive-current requirements to one-half of that required for a standard Series 54/74 TTL input. The serial-count-enable, actually two internal emitters, is rated as one standard Series 54/74 load. The logic outputs, except RBO, have active pull-ups.

The SN54143 and SN74143 driver outputs are designed specifically to maintain a relatively constant on-level sink current of approximately 15 milliamperes from output "a" through "g" and seven milliamperes from output "dp" over a voltage range from one to five volts. Any number of LED's in series may be driven as long as the output voltage rating is not exceeded.

The SN54144 and SN74144 have high-sink-current saturated outputs for driving indicators having voltage ratings up to 15 volts or requiring up to 25 milliamperes drive. The SN54144 sinks 20 milliamperes and the SN74144 sinks 25 milliamperes at an on-level voltage of 0.6 volts across their respective operating temperature ranges.

All inputs are diode-clamped to minimize transmission-line effects, thereby simplifying system design. Maximum clock frequency is typically 18 megahertz and power dissipation is typically 280 milliwatts. The SN54143 and SN54144 are characterized for operation over the full military temperature range of -55°C to 125°C; the SN74143 and SN74144 are characterized for operation from 0°C to 70°C.

[†] Trademark of RCA

PRODUCTION DATA
This document contains information current as of publication date. Products conform to specifications per the terms of Texas Instruments standard warranty. Production processing does not necessarily include testing of all parameters.

**TEXAS
INSTRUMENTS**

POST OFFICE BOX 225012 • DALLAS, TEXAS 75265



TYPES SN54143, SN54144, SN74143, SN74144 4-BIT COUNTER/LATCH, SEVEN-SEGMENT LED/LAMP DRIVERS

description (continued)

Functions of the inputs and outputs of these devices are as follows:

FUNCTION	PIN NO.	DESCRIPTION
CLEAR INPUT	3	When low, resets and holds counter at 0. Must be high for normal counting.
CLOCK INPUT	2	Each positive-going transition will increment the counter provided that the circuit is in the normal counting mode (serial and parallel count enable inputs low, clear input high).
PARALLEL COUNT ENABLE INPUT (PCEI)	23	Must be low for normal counting mode. When high, counter will be inhibited. Logic level must not be changed when the clock is low.
SERIAL COUNT ENABLE INPUT (SCEI)	1	Must be low for normal counting mode, also must be low to enable maximum count output to go low. When high, counter will be inhibited and maximum count output will be driven high. Logic level must not be changed when the clock is low.
MAXIMUM COUNT OUTPUT	22	Will go low when the counter is at 9 and serial count enable input is low. Will return high when the counter changes to 0 and will remain high during counts 1 through 8. Will remain high (inhibited) as long as serial count enable input is high.
LATCH STROBE INPUT	21	When low, data in latches follow the data in the counter. When high, the data in the latches are held constant, and the counter may be operated independently.
LATCH OUTPUTS (QA, QB, QC, QD)	17, 18, 19, 20	The BCD data that drives the decoder can be stored in the 4-bit latch and is available at these outputs for driving other logic and/or processors. The binary weights of the outputs are: QA = 1, QB = 2, QC = 4, QD = 8.
DECIMAL POINT INPUT	7	Must be high to display decimal point. The decimal point is not displayed when this input is low or when the display is blanked.
BLANKING INPUT (BI)	5	When high, will blank (turn off) the entire display and force $\overline{RB0}$ low. Must be low for normal display. May be pulsed to implement intensity control of the display.
RIPPLE-BLANKING INPUT (\overline{RBI})	4	When the data in the latches is BCD 0, a low input will blank the entire display and force the $\overline{RB0}$ low. This input has no effect if the data in the latches is other than 0.
RIPPLE-BLANKING OUTPUT (\overline{RBO})	6	Supplies ripple blanking information for the ripple blanking input of the next decade. Provides a low if BI is high, or if \overline{RBI} is low and the data in the latches in BCD 0; otherwise, this output is high. This pin has a resistive pull-up circuit suitable for performing a wire-AND function with any open-collector output. Whenever this pin is low the entire display will be blanked; therefore, this pin may be used as an active-low blanking input.
LED/LAMP DRIVER OUTPUTS (a, b, c, d, e, f, g, dp)	15, 16, 14, 9, 11, 10, 13, 8	Outputs for driving seven-segment LED's or lamps and their decimal points. See segment identification and resultant displays on following page.



SEGMENT IDENTIFICATION

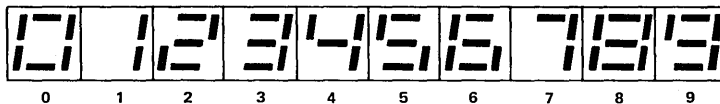

NUMERICAL DESIGNATIONS—RESULTANT DISPLAYS

TYPES SN54143, SN54144, SN74143, SN74144
4-BIT COUNTER/LATCH, SEVEN-SEGMENT LED/LAMP DRIVERS

logic diagram

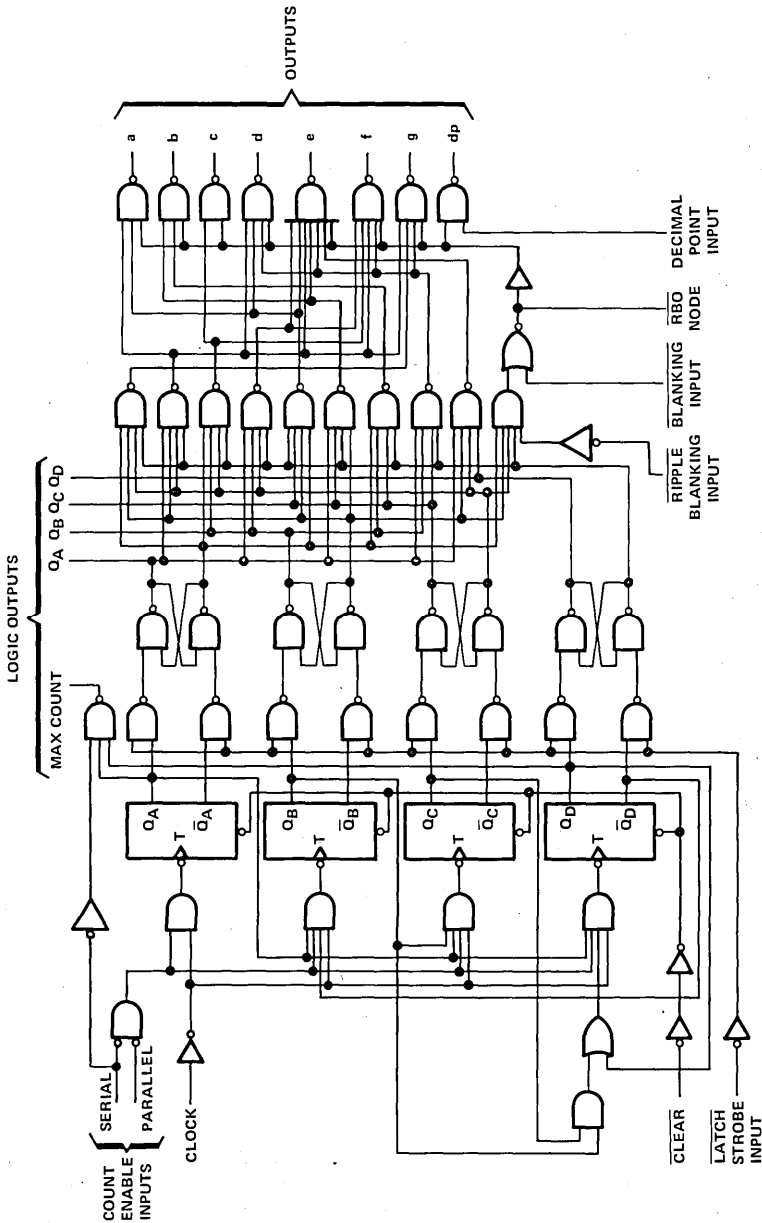

TYPES SN54143, SN54144, SN74143, SN74144 4-BIT COUNTER/LATCH, SEVEN-SEGMENT LED/LAMP DRIVERS

schematics of inputs and outputs

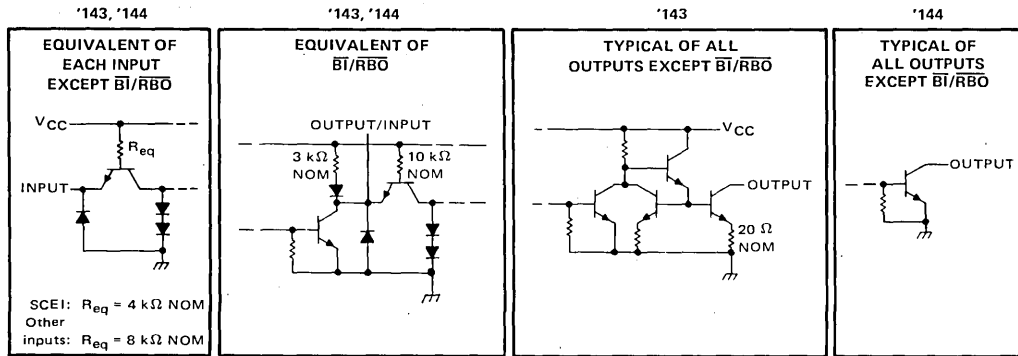

absolute maximum ratings over operating free-air temperature range (unless otherwise noted)

Supply voltage, V _{CC} (see Note 1)	7 V
Input voltage	5.5 V
Off-state voltage at outputs "a" thru "g" and "dp", '144	15 V
Off-state current at outputs "a" thru "g" and "dp", '143	250 μA
Continuous total power dissipation at (or below) 70°C free-air temperature (see Note 2)	1.4 W
Operating free-air temperature range: SN54' Circuits	-55°C to 125°C
SN74' Circuits	0°C to 70°C
Storage temperature range	-65°C to 150°C

NOTES: 1. Voltage values are with respect to network ground terminal.

2. For the SN54143 and SN54144 in the N and W packages, this rating applies at (or below) 80°C free-air temperature. For operation above this temperature, derate linearly at the rate of 11.7 mW/°C for the W package and 14.7 mW/°C for the N package. No derating is required for these devices in the J package.

recommended operating conditions

	SN54143, SN54144			SN74143, SN74144			UNIT
	MIN	NOM	MAX	MIN	NOM	MAX	
Supply voltage, V _{CC}	4.5	5	5.5	4.75	5	5.25	V
On-state voltage at outputs a thru g and dp ('143 only)	1			5			V
High-level output current, I _{OH}	Q _A , Q _B , Q _C , Q _D			-240			μA
	Maximum count			-560			
	R _{BO}			-120			
Low-level output current, I _{OL}	Q _A , Q _B , Q _C , Q _D , R _{BO}			4.8			mA
	Maximum count			11.2			
Clock pulse width, t _{w(clock)}	High logic level			25			ns
	Low logic level			55			
Clear pulse width, t _{w(clear)}	25			25			ns
Setup time, t _{su}	Serial and parallel carry			30†			ns
	Clear inactive state			60†			
Operating free-air temperature, T _A	-55		125	0		70	°C

†The arrow indicates that the rising edge of the clock pulse is used for reference.

3 TTL DEVICES

TYPES SN54143, SN54144, SN74143, SN74144 4-BIT COUNTER/LATCH, SEVEN-SEGMENT LED/LAMP DRIVERS

electrical characteristics over recommended operating free-air temperature range (unless otherwise noted)

PARAMETER		TEST CONDITIONS†	SN54143, SN74143			SN54144, SN74144			UNIT
			MIN	TYP‡	MAX	MIN	TYP‡	MAX	
V _{IH}	High-level input voltage		2			2			V
V _{IL}	Low-level input voltage		0.8			0.8			V
V _{IK}	Input clamp voltage	V _{CC} = MIN, I _I = -12 mA	-1.5			-1.5			V
V _{OH}	High-level output voltage	R _{BO}	V _{CC} = MIN, V _{IH} = 2 V, V _{IL} = 0.8 V, I _{OH} = MAX			2.4			V
		Q _A , Q _B , Q _C , Q _D							
		Maximum count							
V _{OL}	Low-level output voltage	Q _A , Q _B , Q _C , Q _D , R _{BO}	V _{CC} = MIN, V _{IH} = 2 V, V _{IL} = 0.8 V, I _{OL} = MAX			0.4			V
		Maximum count							
V _{O(off)}	Off-state output voltage	Outputs a thru g, dp	V _{CC} = MAX, I _{OH} = 250 μA			7			V
V _{O(on)}	On-State output voltage	Outputs a thru g, dp	V _{CC} = MIN, See Note 3			15			V
I _{O(on)}	On-state output current	Outputs a thru g	V _{CC} = MIN, V _O = 1 V			9 15			mA
			V _{CC} = 5 V, V _O = 2 V			15			
			V _{CC} = MAX, V _O = 5 V			15 22			
		Output dp	V _{CC} = MIN, V _O = 1 V			4.5 7			
			V _{CC} = 5 V, V _O = 2 V			7			
			V _{CC} = MAX, V _O = 5 V			7 12			
I _I	Input current at maximum input voltage	V _{CC} = MAX, V _I = 5.5 V	1			1			mA
I _{IH}	High-level input current	Serial carry	V _{CC} = MAX, V _I = 2.4 V			40			mA
		R _{BO} node				-0.12 -0.5			
		Other inputs				20			
I _{IL}	Low-level input current	Serial carry	V _{CC} = MAX, V _I = 0.4 V, See Note 4			-1.6			mA
		R _{BO} node				-1.5 -2.4			
		Other inputs				-0.8			
I _{OS}	Short-circuit output current	Q _A , Q _B , Q _C , Q _D	V _{CC} = MAX			-9 -27.5			mA
		Maximum count				-15 -55			
I _{CC}	Supply current	V _{CC} = MAX, See Note 5	56 93			56 93			mA

† For conditions shown as MIN or MAX, use the appropriate value specified under recommended operating conditions for the applicable type.

‡ All typical values are at V_{CC} = 5 V, T_A = 25°C.

NOTES: 3. For SN54144, I_{OL} = 20 mA; for SN74144, I_{OL} = 25 mA.

4. I_{IL} at R_{BO} node is tested with \overline{BI} grounded and RBI at 4.5 V.

5. I_{CC} is measured after the following conditions are established:

a) Strobe = \overline{RBI} = DP = 4.5 V

b) Parallel count enable = serial count enable = \overline{BI} = GND

c) Clear (\overline{CLR}) then clock until all outputs are on (\overline{L})

d) For '143, outputs "a" through "g" and "dp" = 2.5 V, all other outputs open. For '144, all outputs are open.

switching characteristics, V_{CC} = 5 V, T_A = 25°C

PARAMETER §	FROM (INPUT)	TO (OUTPUT)	TEST CONDITIONS	MIN	TYP	MAX	UNIT
f _{max}				12	18		MHz
t _{PLH}	Serial look-ahead	Maximum count	C _L = 15 pF, R _L = 560 Ω, See Note 6	12 20		ns	
t _{PHL}				23 35			
t _{PLH}	Clock	Maximum count		26 40		ns	
t _{PHL}				29 45			
t _{PLH}	Clock	Q _A , Q _B , Q _C , Q _D		28 45		ns	
t _{PHL}				38 60			
t _{PHL}	Clear	Q _A , Q _B , Q _C , Q _D	57 90		ns		

§ f_{max} Maximum clock frequency, t_{PLH} Propagation delay time, low-to-high-level output,

t_{PHL} Propagation delay time, high-to-low-level output

NOTE 6: See General Information Section for load circuits and voltage waveforms.

TYPICAL APPLICATION DATA

This application demonstrates how the drivers may be cascaded for N-bit display applications. It features:

- Synchronous, look-ahead counting
- Ripple blanking of leading zeros; blanking of trailing zeros (not illustrated) can also be implemented
- Overriding blanking for total suppression or intensity modulation of display
- Direct parallel clear
- Latch strobe permits counter to acquire next display while viewing current display

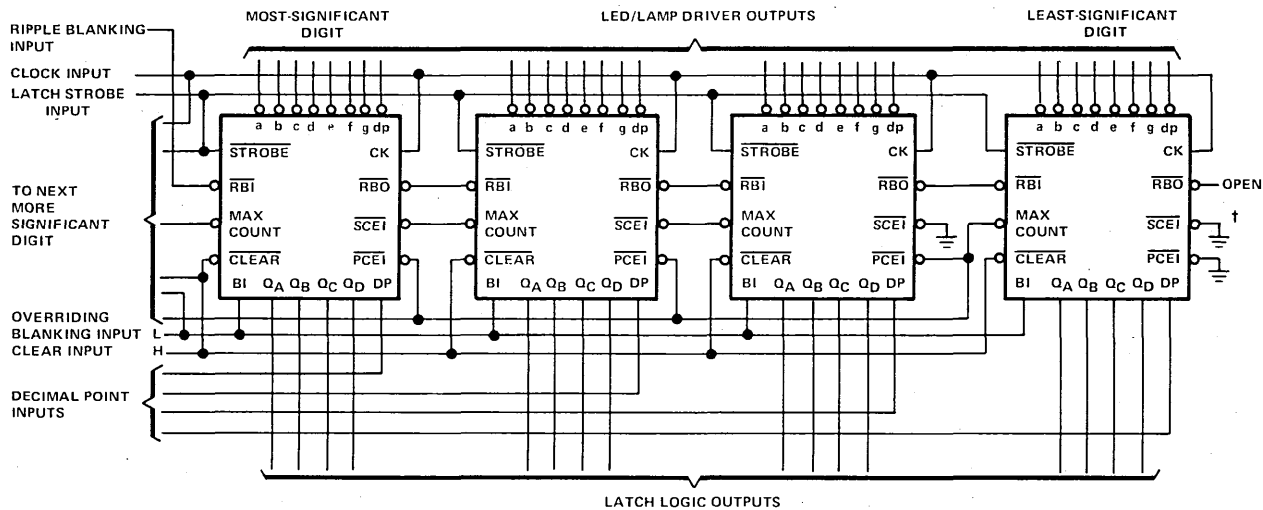

† The serial count-enable input of the least-significant digit is normally grounded; however, it may be used as a count-enable control for the entire counter (high to disable, low to count) provided the logic level on this pin is not changed while the clock line is low or false counting may result.

FUNCTION TABLE

FUNCTION	CLOCK PULSE	INPUTS							RBI/RBO	MAXIMUM COUNT OUTPUT	LATCH		LED/LAMP DRIVERS										TYPICAL DISPLAY	NOTES		
		CLEAR	LATCH STROBE	RBI	$\bar{B}1$	DECIMAL INPUT	SERIAL CARRY	PARALLEL CARRY			Q _D	Q _C	Q _B	Q _A	a	b	c	d	e	f	g	dp				
Clear/Ripple Blank		L	L	L	X	X	X	X	L	H	L	L	L	L	OFF	OFF	OFF	OFF	OFF	OFF	OFF	OFF	OFF	OFF	None	A, E
Blank		H	L	X	H	X	X	X	L	H	L	L	L	L	OFF	OFF	OFF	OFF	OFF	OFF	OFF	OFF	OFF	None	A, D, E	
Decimal	0	H	L	H	L	H	L	L	H	H	L	L	L	L	ON	ON	ON	ON	ON	ON	OFF	ON		B		
	1	H	L	H	L	L	L	L	H	H	L	L	L	H	OFF	ON	ON	OFF	OFF	OFF	OFF	OFF		B		
	2	H	L	H	L	L	L	L	H	H	L	L	H	L	ON	ON	OFF	ON	ON	OFF	ON	OFF		B		
	3	H	L	H	L	L	L	L	H	H	L	L	H	H	ON	ON	ON	ON	OFF	OFF	ON	OFF		B		
	4	H	L	H	L	L	L	L	H	H	L	H	L	L	OFF	ON	ON	OFF	OFF	ON	ON	OFF		B		
	5	H	L	H	L	L	L	L	H	H	L	H	L	H	ON	OFF	ON	ON	OFF	ON	ON	OFF		B		
	6	H	L	H	L	L	L	L	H	H	L	H	H	L	ON	OFF	ON	ON	ON	ON	ON	OFF		B		
	7	H	L	H	L	L	L	L	H	H	L	H	H	H	ON	ON	ON	OFF	OFF	OFF	OFF	OFF		B		
	8	H	L	H	L	L	L	L	H	H	H	L	L	L	ON	ON	ON	ON	ON	ON	ON	ON	OFF		B	
	9	H	L	H	L	L	L	L	H	L	H	L	L	H	ON	ON	ON	ON	OFF	ON	ON	OFF		B		
Ripple Blank	0	H	L	H	L	L	L	L	H	H	L	L	L	L	ON	ON	ON	ON	ON	ON	OFF	OFF		B, C		
	1	H	L	H	L	L	L	L	H	H	L	L	L	H	OFF	ON	ON	OFF	OFF	OFF	OFF	OFF		B		
	2	H	L	H	L	L	L	L	H	H	L	L	H	L	ON	ON	OFF	ON	ON	OFF	ON	OFF		B		
	3	H	L	H	L	L	L	L	H	H	L	L	H	H	ON	ON	ON	ON	OFF	OFF	ON	OFF		B		
	4	H	L	H	L	L	L	L	H	H	L	H	L	L	OFF	ON	ON	OFF	OFF	ON	ON	OFF		B		
	5	H	L	H	L	L	L	L	H	H	L	H	L	H	ON	OFF	ON	ON	OFF	ON	ON	OFF		B		
	6	H	L	H	L	L	L	L	H	H	L	H	L	H	ON	OFF	ON	ON	OFF	ON	ON	OFF		B		
	7	H	L	H	L	L	L	L	H	H	L	H	L	H	ON	OFF	ON	ON	OFF	ON	ON	OFF		B		
	8	H	L	H	L	L	L	L	H	H	H	L	L	L	ON	ON	ON	ON	ON	ON	ON	ON	OFF		B	
	9	H	L	H	L	L	L	L	H	L	H	L	L	H	ON	ON	ON	ON	OFF	ON	ON	OFF		B		
Ripple Blank	0	H	L	L	X	L	L	L	L	H	L	L	L	OFF	OFF	OFF	OFF	OFF	OFF	OFF	OFF	OFF	None	A, B, E		

- NOTES: A. \bar{RBI}/\bar{RBO} is wire-AND logic serving as ripple blanking input (\bar{RBI}) and/or ripple blanking output (\bar{RBO}).
- B. The blanking input ($\bar{B}1$) must be low when functions DECIMAL/0 through 20/RIPPLE BLANK are desired.
- C. The ripple-blanking input (\bar{RBI}) must be open or high to display a zero during the decimal 0 input.
- D. When a high logic level is applied directly to the blanking input ($\bar{B}1$) all segment outputs are off regardless of any other input condition.
- E. When the ripple-blanking input (\bar{RBI}) and outputs Q_A through Q_D are at a low logic level, all segment outputs are off and the ripple-blanking output (\bar{RBO}) goes to a low logic level (response condition).

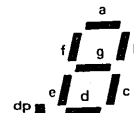

SEGMENT IDENTIFICATION

4-BIT COUNTER/LATCH, SEVEN-SEGMENT LED/LAMP DRIVERS
 TYPES SN54143, SN54144, SN74143, SN74144

TYPES SN54145, SN54LS145, SN74145, SN74LS145 BCD-TO-DECIMAL DECODERS/DRIVERS

MARCH 1974—REVISED DECEMBER 1983

FOR USE AS LAMP, RELAY, OR MOS DRIVERS

- Full Decoding of Input Logic
- SN54145, SN74145, and SN74LS145 Have 80-mA Sink-Current Capability
- All Outputs Are Off for Invalid BCD Input Conditions
- Low Power Dissipation of 'LS145 ... 35 mW Typical

logic

FUNCTION TABLE

NO.	INPUTS				OUTPUTS										
	D	C	B	A	0	1	2	3	4	5	6	7	8	9	
0	L	L	L	L	L	H	H	H	H	H	H	H	H	H	H
1	L	L	L	H	H	L	H	H	H	H	H	H	H	H	H
2	L	L	H	L	H	H	L	H	H	H	H	H	H	H	H
3	L	L	H	H	H	H	H	L	H	H	H	H	H	H	H
4	L	H	L	L	H	H	H	H	L	H	H	H	H	H	H
5	L	H	L	H	H	H	H	H	H	L	H	H	H	H	H
6	L	H	H	L	H	H	H	H	H	H	L	H	H	H	H
7	L	H	H	H	H	H	H	H	H	H	H	L	H	H	H
8	H	L	L	L	H	H	H	H	H	H	H	H	L	H	H
9	H	L	L	H	H	H	H	H	H	H	H	H	H	L	H
INVALID	H	L	H	L	H	H	H	H	H	H	H	H	H	H	H
	H	L	H	H	H	H	H	H	H	H	H	H	H	H	H
	H	H	L	L	H	H	H	H	H	H	H	H	H	H	H
	H	H	L	H	H	H	H	H	H	H	H	H	H	H	H
	H	H	H	L	H	H	H	H	H	H	H	H	H	H	H

H = high level (off), L = low level (on)

description

These monolithic BCD-to-decimal decoder/drivers consist of eight inverters and ten four-input NAND gates. The inverters are connected in pairs to make BCD input data available for decoding by the NAND gates. Full decoding of valid BCD input logic ensures that all outputs remain off for all invalid binary input conditions. These decoders feature high-performance, n-p-n output transistors designed for use as indicator/relay drivers or as open-collector logic-circuit drivers. Each of the high-breakdown output transistors (15 volts) of the SN54145, SN74145, or SN74LS145 will sink up to 80 milliamperes of current. Each input is one Series 54/74 or Series 54LS/74LS standard load, respectively. Inputs and outputs are entirely compatible for use with TTL or DTL logic circuits, and the outputs are compatible for interfacing with most MOS integrated circuits. Power dissipation is typically 215 milliwatts for the '145 and 35 milliwatts for the 'LS145.

SN54145, SN54LS145 ... J OR W PACKAGE
SN74145 ... J OR N PACKAGE
SN74LS145 ... D, J OR N PACKAGE

(TOP VIEW)

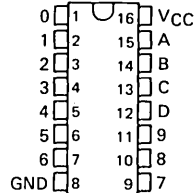

SN54LS145 ... FK PACKAGE
SN74LS145 ... FN PACKAGE

(TOP VIEW)

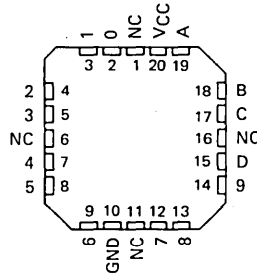

NC - No internal connection

logic diagram

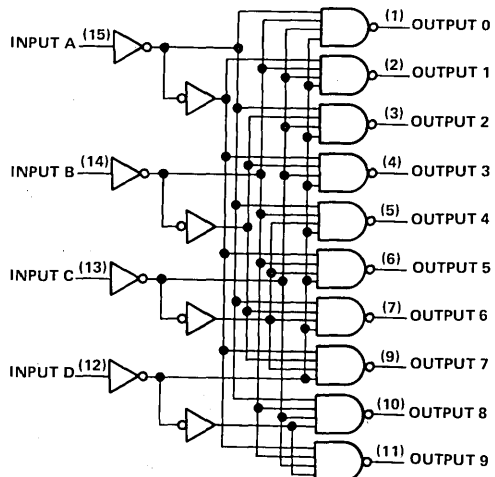

Pin numbers shown on logic notation are for D, J or N packages.

PRODUCTION DATA

This document contains information current as of publication date. Products conform to specifications per the terms of Texas Instruments standard warranty. Production processing does not necessarily include testing of all parameters.

3-552

**TEXAS
INSTRUMENTS**

POST OFFICE BOX 225012 • DALLAS, TEXAS 75265

TYPES SN54LS145, SN74LS145 BCD-TO-DECIMAL DECODERS/DRIVERS

absolute maximum ratings over operating free-air temperature range (unless otherwise noted)

Supply voltage, V_{CC} (see Note 1)	7 V
Input voltage	5.5 V
Maximum current into any output (off-state)	1 mA
Operating free-air temperature range: SN54145	-55°C to 125°C
SN74145	0°C to 70°C
Storage temperature range	-65°C to 150°C

NOTE 1: Voltage values are with respect to network ground terminal.

recommended operating conditions

	SN54145			SN74145			UNIT		
	MIN	NOM	MAX	MIN	NOM	MAX			
Supply voltage, V_{CC}	4.5	5	5.5	4.75	5	5.25	V		
Off-state output voltage, $V_{O(off)}$	15			15			V		
Operating free-air temperature, T_A	-55			125			0	70	°C

electrical characteristics over recommended operating free-air temperature range (unless otherwise noted)

PARAMETER	TEST CONDITIONS†	MIN	TYP‡	MAX	UNIT
V_{IH} High-level input voltage		2			V
V_{IL} Low-level input voltage				0.8	V
V_{IK} Input clamp voltage	$V_{CC} = \text{MIN}, I_I = -12 \text{ mA}$			-1.5	V
$I_{O(off)}$ Off-state output current	$V_{CC} = \text{MIN}, V_{IH} = 2 \text{ V}, V_{IL} = 0.8 \text{ V}, V_{O(off)} = 15 \text{ V}$			250	μA
$V_{O(on)}$ On-state output voltage	$V_{CC} = \text{MIN}, V_{IH} = 2 \text{ V}, V_{IL} = 0.8 \text{ V}$	$I_{O(on)} = 80 \text{ mA}$		0.5	0.9
		$I_{O(on)} = 20 \text{ mA}$		0.4	
I_I Input current at maximum input voltage	$V_{CC} = \text{MAX}, V_I = 5.5 \text{ V}$			1	mA
I_{IH} High-level input current	$V_{CC} = \text{MAX}, V_I = 2.4 \text{ V}$			40	μA
I_{IL} Low-level input current	$V_{CC} = \text{MAX}, V_I = 0.4 \text{ V}$			-1.6	mA
I_{CC} Supply current	$V_{CC} = \text{MAX}$, See Note 2	SN54145		43	62
		SN74145		43	70

† For conditions shown as MIN or MAX, use the appropriate value specified under recommended operating conditions.

‡ All typical values are at $V_{CC} = 5 \text{ V}, T_A = 25^\circ\text{C}$.

NOTE 2: I_{CC} is measured with all inputs grounded and outputs open.

switching characteristics, $V_{CC} = 5 \text{ V}, T_A = 25^\circ\text{C}$

PARAMETER	TEST CONDITIONS	MIN	MAX	UNIT
t_{PLH} Propagation delay time, low-to-high-level output	$C_L = 15 \text{ pF}, R_L = 100 \Omega$, See Note 3			50
t_{PHL} Propagation delay time, high-to-low-level output				50

NOTE 3: See General Information Section for load circuits and voltage waveforms.

schematics of inputs and outputs

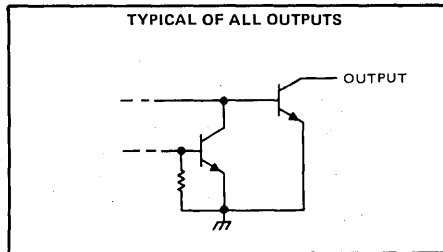
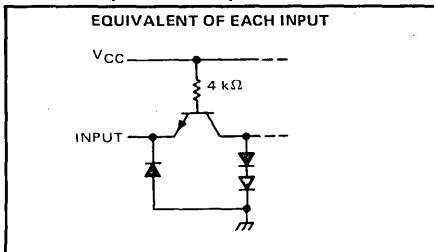

3
TTL DEVICES

TYPES SN54145, SN74145 BCD-TO-DECIMAL DECODERS/DRIVERS

absolute maximum ratings over operating free-air temperature range (unless otherwise noted)

Supply voltage, V_{CC} (see Note 1)	7 V
Input voltage	7 V
Operating free-air temperature range: SN54LS145	-55°C to 125°C
SN74LS145	0°C to 70°C
Storage temperature range	-65°C to 150°C

NOTE 1: Voltage values are with respect to network ground terminal.

recommended operating conditions

	SN54LS145			SN74LS145			UNIT		
	MIN	NOM	MAX	MIN	NOM	MAX			
Supply voltage, V_{CC}	4.5	5	5.5	4.75	5	5.25	V		
Off-state output voltage, $V_{O(off)}$	15						15	V	
Operating free-air temperature, T_A	-55			125			0	70	°C

electrical characteristics over recommended operating free-air temperature range (unless otherwise noted)

PARAMETER	TEST CONDITIONS†	SN54LS145			SN74LS145			UNIT
		MIN	TYP‡	MAX	MIN	TYP‡	MAX	
V_{IH} High-level input voltage		2			2			V
V_{IL} Low-level input voltage		0.7			0.8			V
V_{IK} Input clamp voltage	$V_{CC} = \text{MIN}, I_I = -18 \text{ mA}$	-1.5			-1.5			V
$I_{O(off)}$ Off-state output current	$V_{CC} = \text{MIN}, V_{IH} = 2 \text{ V}, V_{IL} = V_{IL \text{ max}}, V_{OH} = 15 \text{ V}$	250			250			μA
$V_{O(on)}$ On-state output voltage	$V_{CC} = \text{MIN}, V_{IH} = 2 \text{ V}, V_{IL} = V_{IL \text{ max}}$	$I_{OL} = 12 \text{ mA}$	0.25	0.4	0.25	0.4	V	
		$I_{OL} = 24 \text{ mA}$				0.35		0.5
		$I_{OL} = 80 \text{ mA}$				2.3		3
I_I Input current at maximum input voltage	$V_{CC} = \text{MAX}, V_I = 7 \text{ V}$	0.1			0.1			mA
I_{IH} High-level input current	$V_{CC} = \text{MAX}, V_I = 2.7 \text{ V}$	20			20			μA
I_{IL} Low-level input current	$V_{CC} = \text{MAX}, V_I = 0.4 \text{ V}$	-0.4			-0.4			mA
I_{CC} Supply current	$V_{CC} = \text{MAX},$ See Note 2	7	13		7	13	mA	

†For conditions shown as MIN or MAX, use the appropriate value specified under recommended operating conditions.

‡All typical values are at $V_{CC} = 5 \text{ V}, T_A = 25^\circ\text{C}$.

NOTE 2: I_{CC} is measured with all inputs grounded and outputs open.

switching characteristics, $V_{CC} = 5 \text{ V}, T_A = 25^\circ\text{C}$

PARAMETER	TEST CONDITIONS	MIN	MAX	UNIT	
t_{PLH} Propagation delay time, low-to-high-level output	$C_L = 45 \text{ pF}, R_L = 665 \Omega,$ See Note 3			50	ns
t_{PHL} Propagation delay time, high-to-low-level output				50	ns

NOTE 3: See General Information Section for load circuits and voltage waveforms.

schematic of inputs and outputs

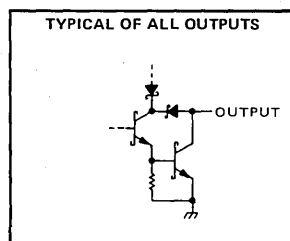
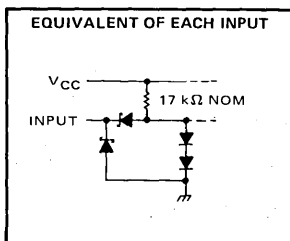

3 TTL DEVICES

TYPES SN54147, SN54148, SN54LS147, SN54LS148, SN74147, SN74148 (TIM9907), SN74LS147, SN74LS148 10-LINE TO 4-LINE AND 8-LINE TO 3-LINE PRIORITY ENCODERS

OCTOBER 1976—REVISED DECEMBER 1983

'147, 'LS147

- Encodes 10-Line Decimal to 4-Line BCD
- Applications Include:

Keyboard Encoding
Range Selection: '148, 'LS148

- Encodes 8 Data Lines to 3-Line Binary (Octal)
- Applications Include:

N-Bit Encoding
Code Converters and Generators

TYPE	TYPICAL	TYPICAL
	DATA DELAY	POWER DISSIPATION
'147	10 ns	225 mW
'148	10 ns	190 mW
'LS147	15 ns	60 mW
'LS148	15 ns	60 mW

description

These TTL encoders feature priority decoding of the inputs to ensure that only the highest-order data line is encoded. The '147 and 'LS147 encode nine data lines to four-line (8-4-2-1) BCD. The implied decimal zero condition requires no input condition as zero is encoded when all nine data lines are at a high logic level. The '148 and 'LS148 encode eight data lines to three-line (4-2-1) binary (octal). Cascading circuitry (enable input EI and enable output EO) has been provided to allow octal expansion without the need for external circuitry. For all types, data inputs and outputs are active at the low logic level. All inputs are buffered to represent one normalized Series 54/74 or 54LS/74LS load, respectively.

'147, 'LS147
FUNCTION TABLE

INPUTS									OUTPUTS			
1	2	3	4	5	6	7	8	9	D	C	B	A
H	H	H	H	H	H	H	H	H	H	H	H	H
X	X	X	X	X	X	X	X	L	L	H	H	L
X	X	X	X	X	X	X	L	H	L	H	H	H
X	X	X	X	X	L	H	H	H	H	L	L	L
X	X	X	X	L	H	H	H	H	H	L	L	H
X	X	L	H	H	H	H	H	H	H	L	L	H
X	L	H	H	H	H	H	H	H	H	H	L	H
L	H	H	H	H	H	H	H	H	H	H	H	L

H = high logic level, L = low logic level, X = irrelevant

SN54147, SN54LS147,
SN54148, SN54LS148 ... J OR W PACKAGE
SN74147, SN74148 ... J OR N PACKAGE
SN74LS147, SN74LS148 ... D, J OR N PACKAGE
(TOP VIEW)

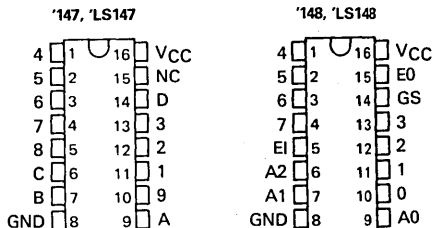

SN54LS147, SN54LS148 ... FK PACKAGE
SN74LS147, SN74LS148 ... FN PACKAGE
(TOP VIEW)

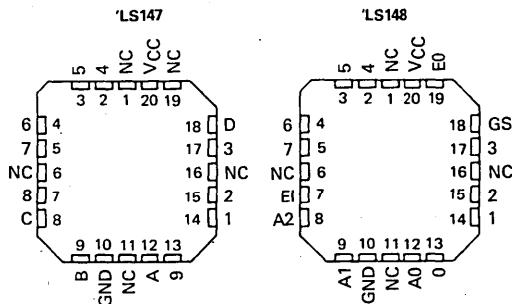

NC - No internal connection

'148, 'LS148
FUNCTION TABLE

INPUTS								OUTPUTS					
EI	0	1	2	3	4	5	6	7	A2	A1	A0	GS	EO
H	X	X	X	X	X	X	X	X	H	H	H	H	H
L	H	H	H	H	H	H	H	H	H	H	H	H	L
L	X	X	X	X	X	X	L	L	L	L	L	L	H
L	X	X	X	X	X	L	H	L	L	L	L	L	H
L	X	X	X	L	H	H	H	L	H	L	L	L	H
L	X	X	L	H	H	H	H	H	L	L	L	L	H
L	X	L	H	H	H	H	H	H	H	L	L	L	H
L	L	H	H	H	H	H	H	H	H	H	H	L	H

PRODUCTION DATA
This document contains information current as of publication date. Products conform to specifications per the terms of Texas Instruments standard warranty. Production processing does not necessarily include testing of all parameters.

TEXAS INSTRUMENTS

POST OFFICE BOX 225012 • DALLAS, TEXAS 75265

TYPES SN54147, SN54148, SN54LS147, SN54LS148,
 SN74147, SN74148 (TIM9907), SN74LS147, SN74LS148
 10-LINE TO 4-LINE AND 8-LINE TO 3-LINE PRIORITY ENCODERS

logic diagram

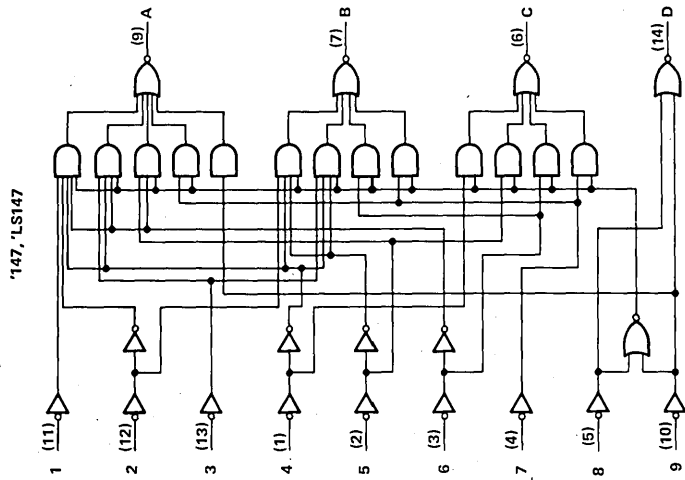
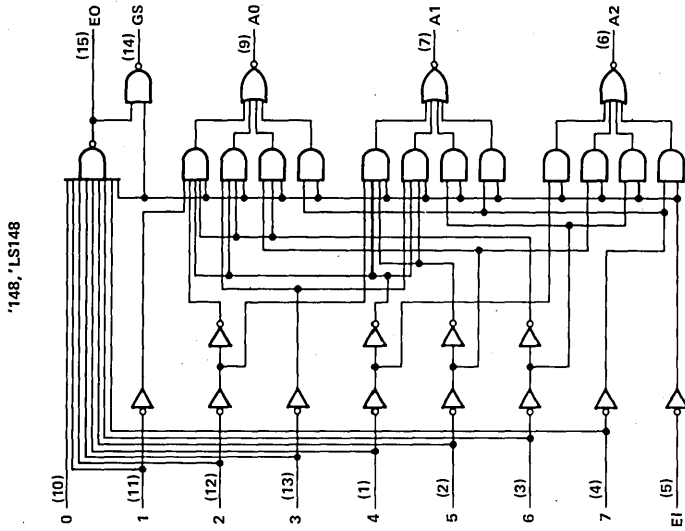

Pin numbers shown on logic notation are for D, J or N packages.

TYPES SN54147, SN54148, SN54LS147, SN54LS148, SN74147, SN74148 (TIM9907), SN74LS147, SN74LS148 10-LINE TO 4-LINE AND 8-LINE TO 3-LINE PRIORITY ENCODERS

schematics of inputs and outputs

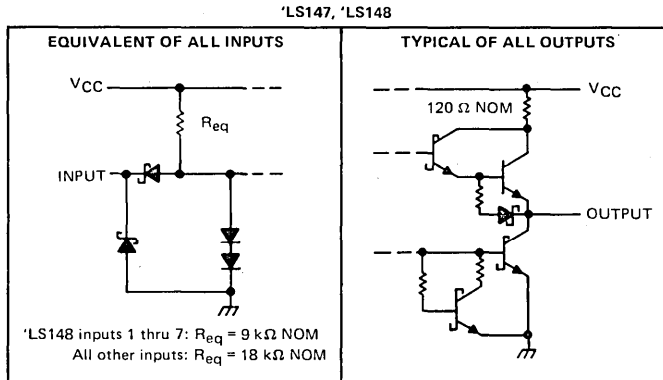
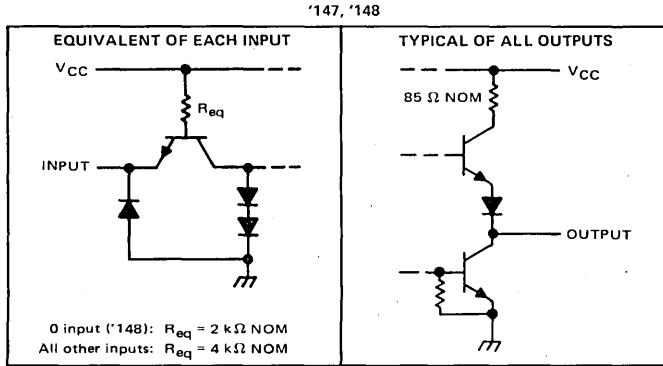

absolute maximum ratings over operating free-air temperature range (unless otherwise noted)

Supply voltage, V_{CC} (see Note 1)	7 V
Input voltage: '147, '148	5.5 V
'LS147, 'LS148	7 V
Intermitter voltage: '148 only (see Note 2)	5.5 V
Operating free-air temperature range: SN54', SN54LS Circuits	-55°C to 125°C
SN74', SN74LS Circuits	0°C to 70°C
Storage temperature range	-65°C to 150°C

- NOTES: 1. Voltage values, except intermitter voltage, are with respect to network ground terminal.
2. This is the voltage between two emitters of a multiple-emitter transistor. For '148 circuits, this rating applies between any two of the eight data lines, 0 through 7.

recommended operating conditions

	SN54'			SN74'			SN54LS'			SN74LS'			UNIT
	MIN	NOM	MAX	MIN	NOM	MAX	MIN	NOM	MAX	MIN	NOM	MAX	
Supply voltage, V_{CC}	4.5	5	5.5	4.75	5	5.25	4.5	5	5.5	4.75	5	5.25	V
High-level output current, I_{OH}			-800			-800			-400			-400	μA
Low-level output current, I_{OL}			16			16			4			8	mA
Operating free-air temperature, T_A	-55		125	0		70	-55		125	0		70	°C

TYPES SN54147, SN54148, SN74147, SN74148 (TIM9907)

10-LINE TO 4-LINE AND 8-LINE TO 3-LINE PRIORITY ENCODERS

electrical characteristics over recommended operating free-air temperature range (unless otherwise noted)

PARAMETER	TEST CONDITIONS†	'147		'148		UNIT	
		MIN	TYP‡	MAX	MIN		TYP‡
V _{IH} High-level input voltage		2		2		V	
V _{IL} Low-level input voltage			0.8		0.8	V	
V _{IK} Input clamp voltage	V _{CC} = MIN, I _I = -12 mA		-1.5		-1.5	V	
V _{OH} High-level output voltage	V _{CC} = MIN, V _{IH} = 2 V, V _{IL} = 0.8 V, I _{OH} = -800 µA	2.4	3.3	2.4	3.3	V	
V _{OL} Low-level output voltage	V _{CC} = MIN, V _{IH} = 2 V, V _{IL} = 0.8 V, I _{OL} = 16 mA	0.2	0.4	0.2	0.4	V	
I _I Input current at maximum input voltage	V _{CC} = MAX, V _I = 5.5 V		1		1	mA	
I _{IH} High-level input current	0 input				40	µA	
	Any input except 0	V _{CC} = MAX, V _I = 2.4 V		40			
I _{IL} Low-level input current	0 input				-1.6	mA	
	Any input except 0	V _{CC} = MAX, V _I = 0.4 V		-1.6	-3.2		
I _{OS} Short-circuit output current‡	V _{CC} = MAX	-35	-85	-35	-85	mA	
I _{CC} Supply current	V _{CC} = MAX, See Note 3	Condition 1	50	70	40	60	mA
	Condition 2	42	62	35	55	mA	

NOTE 3: For '147, I_{CC} (condition 1) is measured with input 7 grounded, other inputs and outputs open; I_{CC} (condition 2) is measured with all inputs and outputs open. For '148, I_{CC} (condition 1) is measured with inputs 7 and E1 grounded, other inputs and outputs open; I_{CC} (condition 2) is measured with all inputs and outputs open.

† For conditions shown as MIN or MAX, use the appropriate value specified under recommended operating conditions.

‡ All typical values are at V_{CC} = 5 V, T_A = 25°C.

§ Not more than one output should be shorted at a time.

SN54147, SN74147 switching characteristics, V_{CC} = 5 V, T_A = 25°C

PARAMETER¶	FROM (INPUT)	TO (OUTPUT)	WAVEFORM	TEST CONDITIONS	MIN	TYP	MAX	UNIT
t _{PLH}	Any	Any	In-phase output	C _L = 15 pF, R _L = 400 Ω, See Note 4	9	14	ns	
t _{PHL}					7	11		
t _{PLH}	Any	Any	Out-of-phase output		13	19	ns	
t _{PHL}					12	19		

SN54148, SN74148 switching characteristics, V_{CC} = 5 V, T_A = 25°C

PARAMETER¶	FROM (INPUT)	TO (OUTPUT)	WAVEFORM	TEST CONDITIONS	MIN	TYP	MAX	UNIT
t _{PLH}	1 thru 7	A0, A1, or A2	In-phase output	C _L = 15 pF, R _L = 400 Ω, See Note 4	10	15	ns	
t _{PHL}					9	14		
t _{PLH}	1 thru 7	A0, A1, or A2	Out-of-phase output		13	19	ns	
t _{PHL}					12	19		
t _{PLH}	0 thru 7	EO	Out-of-phase output		6	10	ns	
t _{PHL}					14	25		
t _{PLH}	0 thru 7	GS	In-phase output		18	30	ns	
t _{PHL}					14	25		
t _{PLH}	E1	A0, A1, or A2	In-phase output		10	15	ns	
t _{PHL}					10	15		
t _{PLH}	E1	GS	In-phase output		8	12	ns	
t _{PHL}					10	15		
t _{PLH}	E1	EO	In-phase output		10	15	ns	
t _{PHL}					17	30		

¶ t_{PLH} ≡ propagation delay time, low-to-high-level output

t_{PHL} ≡ propagation delay time, high-to-low level output

NOTE 4: See General Information Section for load circuits and voltage waveforms.

3

TTL DEVICES

TYPES SN54LS147, SN54LS148, SN74LS147, SN74LS148 10-LINE TO 4-LINE AND 8-LINE TO 3-LINE PRIORITY ENCODERS

electrical characteristics over recommended operating free-air temperature range (unless otherwise noted)

PARAMETER	TEST CONDITIONS†	SN54LS*		SN74LS*		UNIT
		MIN	TYP‡	MAX	MIN	
V _{IH} High-level input voltage		2		2		V
V _{IL} Low-level input voltage				0.7		0.8 V
V _{IK} Input clamp voltage	V _{CC} = MIN, I _I = -18 mA	-1.5		-1.5		V
V _{OH} High-level output voltage	V _{CC} = MIN, V _{IH} = 2 V, V _{IL} = 0.8 V, I _{OH} = -400 µA	2.5	3.4	2.7	3.4	V
V _{OL} Low-level output voltage	V _{CC} = MIN, V _{IH} = 2 V, V _{IL} = V _{ILmax} , I _{OL} = 4 mA	0.25 0.4		0.25 0.4		V
	I _{OL} = 8 mA			0.35 0.5		
I _I Input current at maximum input voltage	'LS148 inputs 1 thru 7			0.2		mA
	All other inputs	V _{CC} = MAX, V _I = 7 V		0.1		
I _{IH} High-level input current	'LS148 inputs 1 thru 7			40		µA
	All other inputs	V _{CC} = MAX, V _I = 2.7 V		20		
I _{IL} Low-level input current	'LS148 inputs 1 thru 7			-0.8		mA
	All other inputs	V _{CC} = MAX, V _I = 0.4 V		-0.4		
I _{OS} Short-circuit output current‡	V _{CC} = MAX	-20	-100	-20	-100	mA
I _{CC} Supply current	V _{CC} = MAX, Condition 1	12	20	12	20	mA
	See Note 5, Condition 2	10	17	10	17	

NOTE 5: For 'LS147, I_{CC} (condition 1) is measured with input 7 grounded, other inputs and outputs open; I_{CC} (condition 2) is measured with all inputs and outputs open. For 'LS148, I_{CC} (condition 1) is measured with inputs 7 and E1 grounded, other inputs and outputs open, I_{CC} (condition 2) is measured with all inputs and outputs open.

†For conditions shown as MIN or MAX, use the appropriate value specified under recommended operating conditions.

‡All typical values are at V_{CC} = 5 V, T_A = 25°C.

§Not more than one output should be shorted at a time.

SN54LS147, SN74LS147 switching characteristics, V_{CC} = 5 V, T_A = 25°C

PARAMETER‡	FROM (INPUT)	TO (OUTPUT)	WAVEFORM	TEST CONDITIONS	MIN	TYP	MAX	UNIT
t _{PLH}	Any	Any	In-phase output	C _L = 15 pF, R _L = 2 kΩ, See Note 4	12 18		ns	
t _{PHL}					12 18			
t _{PLH}	Any	Any	Out-of-phase output		21 33		ns	
t _{PHL}					15 23			

SN54LS148, SN74LS148 switching characteristics, V_{CC} = 5 V, T_A = 25°C

PARAMETER‡	FROM (INPUT)	TO (OUTPUT)	WAVEFORM	TEST CONDITIONS	MIN	TYP	MAX	UNIT
t _{PLH}	1 thru 7	A0, A1, or A2	In-phase output	C _L = 15 pF, R _L = 2 kΩ, See Note 4	14 18		ns	
t _{PHL}					15 25			
t _{PLH}	1 thru 7	A0, A1, or A2	Out-of-phase output		20 36		ns	
t _{PHL}					16 29			
t _{PLH}	0 thru 7	EO	Out-of-phase output		7 18		ns	
t _{PHL}					25 40			
t _{PLH}	0 thru 7	GS	In-phase output		35 55		ns	
t _{PHL}					9 21			
t _{PLH}	E1	A0, A1, or A2	In-phase output		16 25		ns	
t _{PHL}					12 25			
t _{PLH}	E1	GS	In-phase output		12 17		ns	
t _{PHL}					14 36			
t _{PLH}	E1	EO	In-phase output		12 21		ns	
t _{PHL}					23 35			

†t_{PLH} = propagation delay time, low-to-high-level output

‡t_{PHL} = propagation delay time, high-to-low-level output

NOTE 4: See General Information Section for load circuits and voltage waveforms.

**TYPES SN54147, SN54148 (TIM9907), SN54LS147, SN54LS148,
SN74147, SN74148, SN74LS147, SN74LS148
10-LINE TO 4-LINE AND 8-LINE TO 3-LINE PRIORITY ENCODERS**

TYPICAL APPLICATION DATA

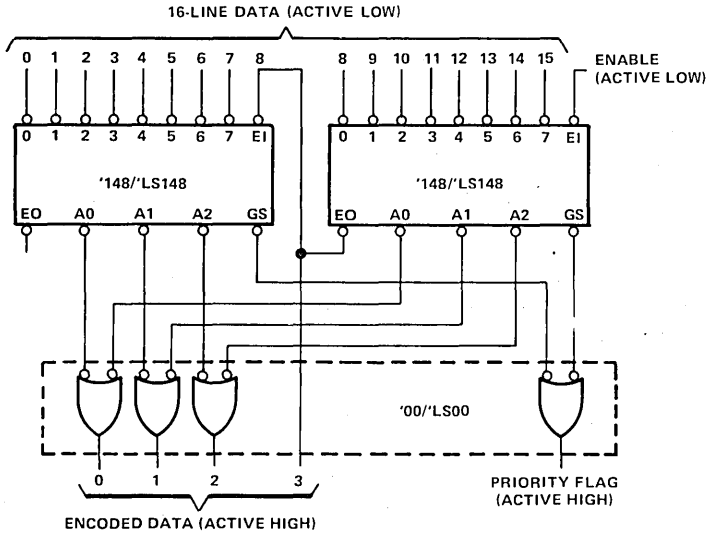
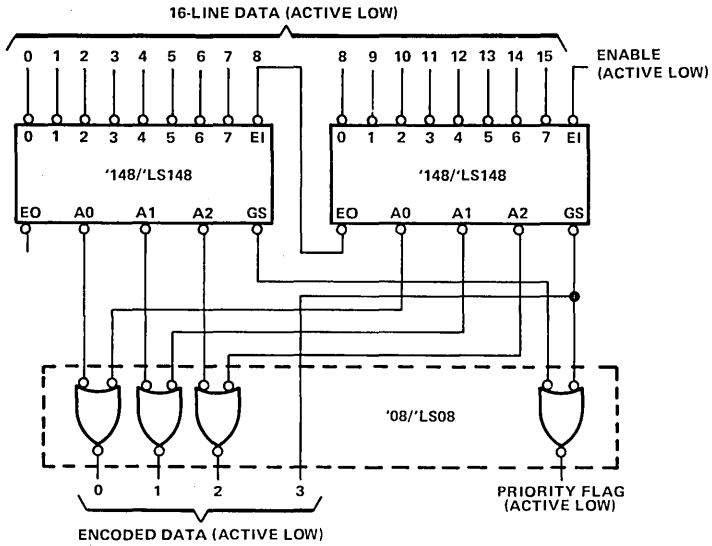

Since the '147/LS147 and '148/LS148 are combinational logic circuits, wrong addresses can appear during input transients. Moreover, for the '148/LS148 a change from high to low at input EI can cause a transient low on the GS output when all inputs are high. This must be considered when strobing the outputs.

TYPES SN54150, SN54151A, SN54152A, SN54LS151, SN54LS152, SN54S151, SN74150, SN74151A, SN74LS151, SN74S151

DATA SELECTORS/MULTIPLEXERS

DECEMBER 1972—REVISED DECEMBER 1983

- '150 Selects One-of-Sixteen Data Sources
- Others Select One-of-Eight Data Sources
- Performs Parallel-to-Serial Conversion
- Permits Multiplexing from N Lines to One Line
- Also For Use as Boolean Function Generator
- Input-Clamping Diodes Simplify System Design
- Fully Compatible with Most TTL Circuits

SN54150 ... J OR W PACKAGE
SN74150 ... J OR N PACKAGE

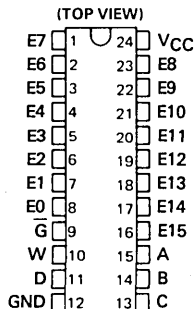

SN54151A, SN54LS151, SN54S151 ... J OR W PACKAGE
SN74151A ... J OR N PACKAGE
SN74LS151, SN74S151 ... D, J OR N PACKAGE

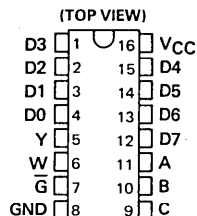

SN54LS151, SN54S151 ... FK PACKAGE
SN74LS151, SN74S151 ... FN PACKAGE

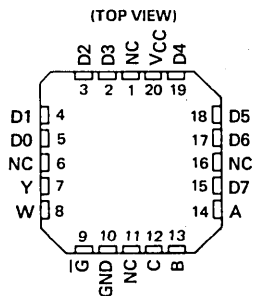

NC - No internal connection

SN54152A, SN54LS152 ... W PACKAGE

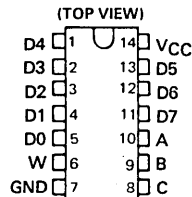

For SN54LS152 Chip Carrier Information, Contact The Factory.

TYPE	TYPICAL AVERAGE		TYPICAL POWER DISSIPATION
	PROPAGATION DELAY TIME	DATA INPUT TO W OUTPUT	
'150	13 ns		200 mW
'151A	8 ns		145 mW
'152A	8 ns		130 mW
'LS151	13 ns		30 mW
'LS152	13 ns		28 mW
'S151	4.5 ns		225 mW

description

These monolithic data selectors/multiplexers contain full on-chip binary decoding to select the desired data source. The '150 selects one-of-sixteen data sources; the '151A, '152A, 'LS151, 'LS152, and 'S151 select one-of-eight data sources. The '150, '151A, 'LS151, and 'S151 have a strobe input which must be at a low logic level to enable these devices. A high level at the strobe forces the W output high, and the Y output (as applicable) low.

The '151A, 'LS151, and 'S151 feature complementary W and Y outputs whereas the '150, '152A, and 'LS152 have an inverted (W) output only.

The '151A and '152A incorporate address buffers which have symmetrical propagation delay times through the complementary paths. This reduces the possibility of transients occurring at the output(s) due to changes made at the select inputs, even when the '151A outputs are enabled (i.e., strobe low).

PRODUCTION DATA
This document contains information current as of publication date. Products conform to specifications per the terms of Texas Instruments standard warranty. Production processing does not necessarily include testing of all parameters.

TEXAS INSTRUMENTS

POST OFFICE BOX 225012 • DALLAS, TEXAS 75265

TTL DEVICES

TYPES SN54150, SN54151A, SN54152A, SN54LS151, SN54LS152, SN54S151,
 SN74150, SN74151A, SN74LS151, SN74S151
 DATA SELECTORS/MULTIPLEXERS

schematics of inputs and outputs

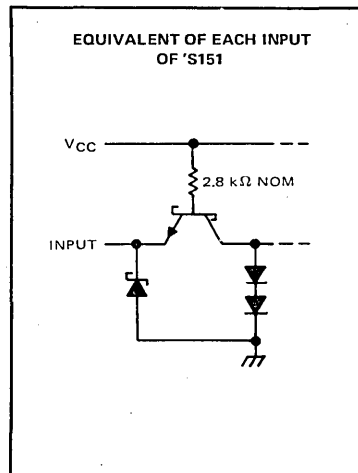
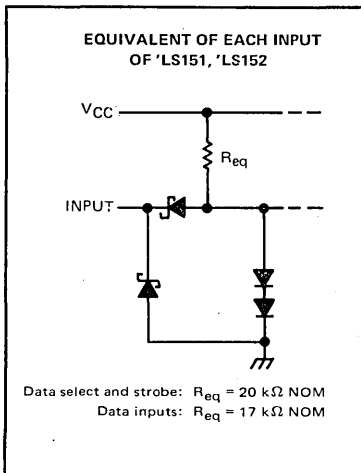
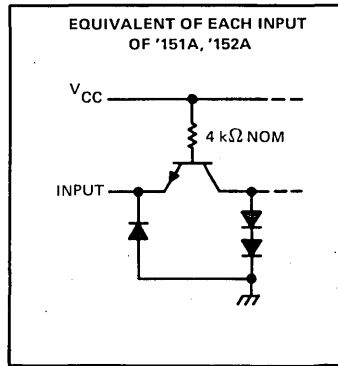
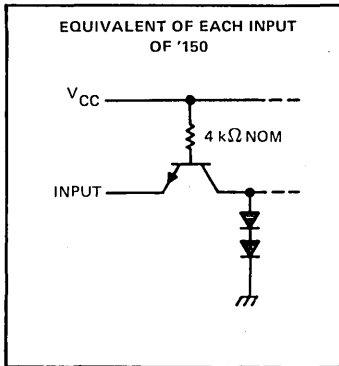

**TYPES SN54150, SN54151A, SN54152A, SN54LS151, SN54LS152, SN54S151
SN74150, SN74151A, SN74LS151, SN74S151
DATA SELECTORS/MULTIPLEXERS**

schematics of inputs and outputs

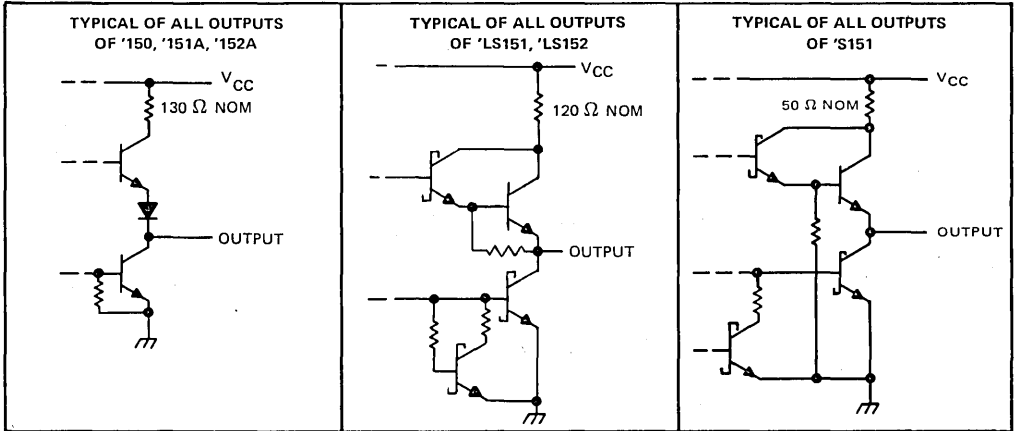

logic

'150

FUNCTION TABLE

INPUTS				STROBE G	OUTPUT W
D	C	B	A		
X	X	X	X	H	H
L	L	L	L	L	$\overline{E0}$
L	L	L	H	L	$\overline{E1}$
L	L	H	L	L	$\overline{E2}$
L	L	H	H	L	$\overline{E3}$
L	H	L	L	L	$\overline{E4}$
L	H	L	H	L	$\overline{E5}$
L	H	H	L	L	$\overline{E6}$
L	H	H	H	L	$\overline{E7}$
H	L	L	L	L	$\overline{E8}$
H	L	L	H	L	$\overline{E9}$
H	L	H	L	L	$\overline{E10}$
H	L	H	H	L	$\overline{E11}$
H	H	L	L	L	$\overline{E12}$
H	H	L	H	L	$\overline{E13}$
H	H	H	L	L	$\overline{E14}$
H	H	H	H	L	$\overline{E15}$

'151A, 'LS151, 'S151

FUNCTION TABLE

INPUTS			STROBE G	OUTPUTS	
C	B	A		Y	W
X	X	X	H	L	H
L	L	L	L	D0	$\overline{D0}$
L	L	H	L	D1	$\overline{D1}$
L	H	L	L	D2	$\overline{D2}$
L	H	H	L	D3	$\overline{D3}$
H	L	L	L	D4	$\overline{D4}$
H	L	H	L	D5	$\overline{D5}$
H	H	L	L	D6	$\overline{D6}$
H	H	H	L	D7	$\overline{D7}$

'152A, 'LS152

FUNCTION TABLE

SELECT INPUTS			OUTPUT W
C	B	A	
L	L	L	$\overline{D0}$
L	L	H	$\overline{D1}$
L	H	L	$\overline{D2}$
L	H	H	$\overline{D3}$
H	L	L	$\overline{D4}$
H	L	H	$\overline{D5}$
H	H	L	$\overline{D6}$
H	H	H	$\overline{D7}$

H = high level, L = low level, X = irrelevant
 $\overline{E0}, \overline{E1} \dots \overline{E15}$ = the complement of the level of the respective E input
 $\overline{D0}, \overline{D1} \dots \overline{D7}$ = the level of the D respective input



TTL DEVICES

**TYPES SN54150, SN54151A, SN54152A, SN54LS151, SN54LS152, SN54S151,
SN74150, SN74151A, SN74LS151, SN74S151
DATA SELECTORS/MULTIPLEXERS**

logic diagrams

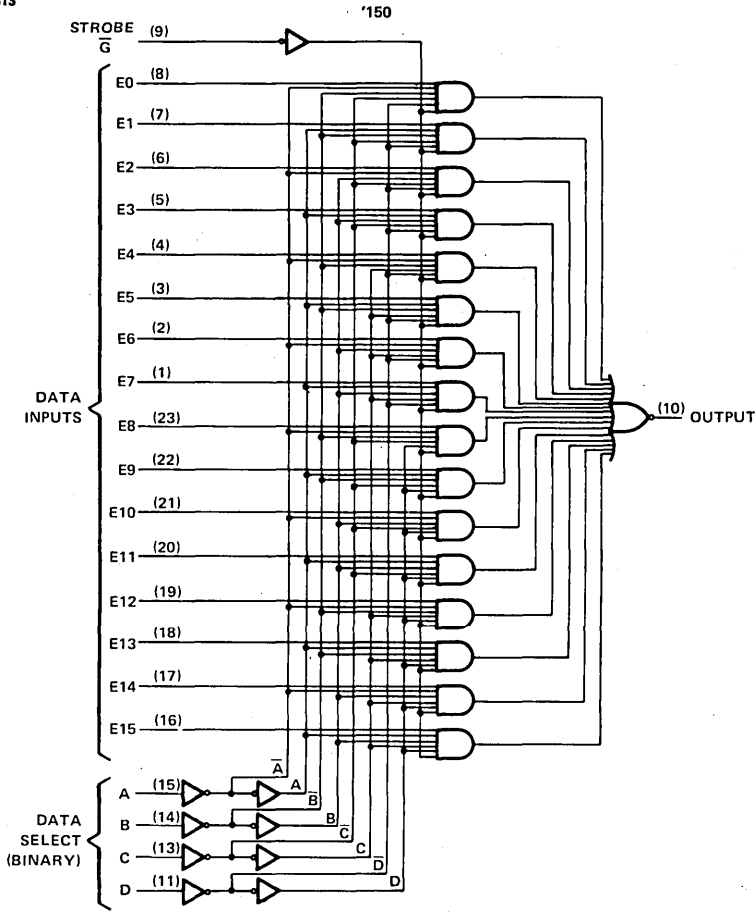

ADDRESS BUFFERS FOR '151A, '152A

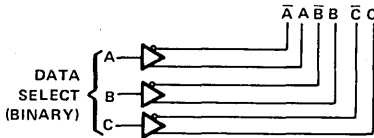

ADDRESS BUFFERS FOR 'LS151, 'S151, 'LS152

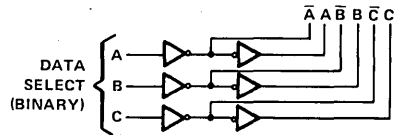

Pin numbers shown on logic notation are for D, J or N packages.

TYPES SN54150, SN54151A, SN54152A, SN74150, SN74151A DATA SELECTORS/MULTIPLEXERS

recommended operating conditions

	SN54'			SN74'			UNIT
	MIN	NOM	MAX	MIN	NOM	MAX	
Supply voltage, V_{CC}	4.5	5	5.5	4.75	5	5.25	V
High-level output current, I_{OH}			-800			-800	μ A
Low-level output current, I_{OL}			16			16	mA
Operating free-air temperature, T_A	-55		125	0		70	$^{\circ}$ C

electrical characteristics over recommended operating free-air temperature range (unless otherwise noted)

PARAMETER	TEST CONDITIONS†	'150			'151A, '152A			UNIT
		MIN	TYP‡	MAX	MIN	TYP‡	MAX	
V_{IH} High-level input voltage		2			2			V
V_{IL} Low-level input voltage				0.8			0.8	V
V_{IK} Input clamp voltage	$V_{CC} = \text{MIN}, I_I = -8 \text{ mA}$						-1.5	V
V_{OH} High-level output voltage	$V_{CC} = \text{MIN}, V_{IH} = 2 \text{ V}, V_{IL} = 0.8 \text{ V}, I_{OH} = -800 \mu\text{A}$	2.4	3.4		2.4	3.4		V
V_{OL} Low-level output voltage	$V_{CC} = \text{MIN}, V_{IH} = 2 \text{ V}, V_{IL} = 0.8 \text{ V}, I_{OL} = 16 \text{ mA}$		0.2	0.4		0.2	0.4	V
I_I Input current at maximum input voltage	$V_{CC} = \text{MAX}, V_I = 5.5 \text{ V}$			1			1	mA
I_{IH} High-level input current	$V_{CC} = \text{MAX}, V_I = 2.4 \text{ V}$			40			40	μ A
I_{IL} Low-level input current	$V_{CC} = \text{MAX}, V_I = 0.4 \text{ V}$			-1.6			-1.6	mA
I_{OS} Short-circuit output current§	$V_{CC} = \text{MAX}$	SN54'	-20	-55	-20	-55		mA
		SN74'	-18	-55	-18	-55		
I_{CC} Supply current	$V_{CC} = \text{MAX},$ See Note 3	'150	40	68				mA
		'151A				29	48	
		'152A				26	43	

† For conditions shown as MIN or MAX, use the appropriate value specified under recommended operating conditions for the applicable device type.

‡ All typical values at $V_{CC} = 5 \text{ V}, T_A = 25^{\circ}\text{C}$.

§ Not more than one output of the '151A should be shorted at a time.

NOTE 3: I_{CC} is measured with the strobe and data select inputs at 4.5 V, all other inputs and outputs open.

switching characteristics, $V_{CC} = 5 \text{ V}, T_A = 25^{\circ}\text{C}$

PARAMETER†	FROM (INPUT)	TO (OUTPUT)	TEST CONDITIONS	'150			'151A, '152A			UNIT
				MIN	TYP	MAX	MIN	TYP	MAX	
t_{PLH}	A, B, or C (4 levels)	Y	$C_L = 15 \text{ pF},$ $R_L = 400 \Omega,$ See Note 4					25	38	ns
t_{PHL}								25	38	
t_{PLH}	A, B, C, or D (3 levels)	W			23	35		17	26	ns
t_{PHL}					22	33		19	30	
t_{PLH}	Strobe \bar{G}	Y						21	33	ns
t_{PHL}								22	33	
t_{PLH}	Strobe \bar{G}	W			15.5	24		14	21	ns
t_{PHL}					21	30		15	23	
t_{PLH}	D0 thru D7	Y						13	20	ns
t_{PHL}								18	27	
t_{PLH}	E0 thru E15, or D0 thru D7	W		8.5	14		8	14	ns	
t_{PHL}				13	20		8	14		

† t_{PLH} \equiv propagation delay time, low-to-high-level output

t_{PHL} \equiv propagation delay time, high-to-low-level output

NOTE 4: See General Information Section for load circuits and voltage waveforms.

3

TTL DEVICES

TYPES SN54LS151, SN54LS152, SN74LS151 DATA SELECTORS/MULTIPLEXERS

recommended operating conditions

	SN54LS'			SN74LS'			UNIT
	MIN	NOM	MAX	MIN	NOM	MAX	
Supply voltage, V_{CC}	4.5	5	5.5	4.75	5	5.25	V
High-level output current, I_{OH}	-400			-400			μ A
Low-level output current, I_{OL}	4			8			mA
Operating free-air temperature, T_A	-55		125	0		70	$^{\circ}$ C

electrical characteristics over recommended operating free-air temperature range (unless otherwise noted)

PARAMETER	TEST CONDITIONS [†]	SN54LS'			SN74LS'			UNIT
		MIN	TYP [‡]	MAX	MIN	TYP [‡]	MAX	
V_{IH} High-level input voltage		2			2			V
V_{IL} Low-level input voltage		0.7			0.8			V
V_{IK} Input clamp voltage	$V_{CC} = \text{MIN}, I_I = -18 \text{ mA}$	-1.5			-1.5			V
V_{OH} High-level output voltage	$V_{CC} = \text{MIN}, V_{IH} = 2 \text{ V}, V_{IL} = V_{IL \text{ max}}, I_{OH} = -400 \mu\text{A}$	2.5	3.4		2.7	3.4		V
V_{OL} Low-level output voltage	$V_{CC} = \text{MIN}, V_{IH} = 2 \text{ V}, V_{IL} = V_{IL \text{ max}}, I_{OL} = 4 \text{ mA}$ $I_{OL} = 8 \text{ mA}$	0.25 0.4		0.25 0.4		0.35 0.5		V
I_I Input current at maximum input voltage	$V_{CC} = \text{MAX}, V_I = 7 \text{ V}$	0.1			0.1			mA
I_{IH} High-level input current	$V_{CC} = \text{MAX}, V_I = 2.7 \text{ V}$	20			20			μ A
I_{IL} Low-level input current	$V_{CC} = \text{MAX}, V_I = 0.4 \text{ V}$	-0.4			-0.4			mA
I_{OS} Short-circuit output current [§]	$V_{CC} = \text{MAX}$	-20 -100		-20 -100		-100		mA
I_{CC} Supply current	$V_{CC} = \text{MAX},$ Outputs open, All inputs at 4.5 V	'LS151 'LS152		6.0 10 5.6 9		6.0 10		mA

[†] For conditions shown as MIN or MAX, use the appropriate value specified under recommended operating conditions for the applicable device type.

[‡] All typical values are at $V_{CC} = 5 \text{ V}, T_A = 25^{\circ}\text{C}$.

[§] Not more than one output should be shorted at a time and duration of short-circuit should not exceed one second.

switching characteristics, $V_{CC} = 5 \text{ V}, T_A = 25^{\circ}\text{C}$

PARAMETER [¶]	FROM (INPUT)	TO (OUTPUT)	TEST CONDITIONS	SN54LS', SN74LS'			UNIT
				MIN	TYP	MAX	
t_{PLH}	A, B, or C (4 levels)	Y	$C_L = 15 \text{ pF},$ $R_L = 2 \text{ k}\Omega,$ See Note 4	27		43	ns
t_{PHL}				18		30	
t_{PLH}	A, B, or C (3 levels)	W		14		23	ns
t_{PHL}				20		32	
t_{PLH}	Strobe \bar{G}	Y		26		42	ns
t_{PHL}				20		32	
t_{PLH}	Strobe \bar{G}	W		15		24	ns
t_{PHL}				18		30	
t_{PLH}	Any D	Y		20		32	ns
t_{PHL}				16		26	
t_{PLH}	Any D	W		13		21	ns
t_{PHL}				12		20	

[¶] t_{PLH} = propagation delay time, low-to-high-level output

[¶] t_{PHL} = propagation delay time, high-to-low-level output

NOTE 4: See General Information Section for load circuits and voltage waveforms.

TYPES SN54S151, SN74S151 DATA SELECTORS/MULTIPLEXERS

recommended operating conditions

	SN54S151			SN74S151			UNIT
	MIN	NOM	MAX	MIN	NOM	MAX	
Supply voltage, V_{CC}	4.5	5	5.5	4.75	5	5.25	V
High-level output current, I_{OH}			-1			-1	mA
Low-level output current, I_{OL}			20			20	mA
Operating free-air temperature, T_A	-55		125	0		70	°C

electrical characteristics over recommended operating free-air temperature range (unless otherwise noted)

PARAMETER	TEST CONDITIONS†	MIN	TYP‡	MAX	UNIT	
V_{IH} High-level input voltage			2		V	
V_{IL} Low-level input voltage				0.8	V	
V_{IK} Input clamp voltage	$V_{CC} = \text{MIN}, I_I = -18 \text{ mA}$			-1.2	V	
V_{OH} High-level output voltage	$V_{CC} = \text{MIN}, V_{IH} = 2 \text{ V},$ $V_{IL} = 0.8 \text{ V}, I_{OH} = -1 \text{ mA}$	SN54S*	2.5	3.4	V	
		SN74S*	2.7	3.4		
V_{OL} Low-level output voltage	$V_{CC} = \text{MIN}, V_{IH} = 2 \text{ V},$ $V_{IL} = 0.8 \text{ V}, I_{OL} = 20 \text{ mA}$			0.5	V	
I_I Input current at maximum input voltage	$V_{CC} = \text{MAX}, V_I = 5.5 \text{ V}$			1	mA	
I_{IH} High-level input current	$V_{CC} = \text{MAX}, V_I = 2.7 \text{ V}$			50	μA	
I_{IL} Low-level input current	$V_{CC} = \text{MAX}, V_I = 0.5 \text{ V}$			-2	mA	
I_{OS} Short-circuit output current§	$V_{CC} = \text{MAX}$			-40	-100	mA
I_{CC} Supply current	$V_{CC} = \text{MAX},$ All inputs at 4.5 V, All outputs open			45	70	mA

† For conditions shown as MIN or MAX, use the appropriate value specified under recommended operating conditions for the applicable device type.

‡ All typical values are at $V_{CC} = 5 \text{ V}, T_A = 25^\circ \text{C}$.

§ Not more than one output should be shorted at a time, and duration of the short-circuit should not exceed one second.

switching characteristics, $V_{CC} = 5 \text{ V}, T_A = 25^\circ \text{C}$

PARAMETER ¶	FROM (INPUT)	TO (OUTPUT)	TEST CONDITIONS	SN54S151, SN74S151			UNIT
				MIN	TYP	MAX	
t_{PLH}	A, B, or C	Y	$C_L = 15 \text{ pF},$ $R_L = 280 \Omega,$ See Note 4	12		18	ns
t_{PHL}	(4 levels)			12		18	
t_{PLH}	A, B, or C	W		10		15	ns
t_{PHL}	(3 levels)			9		13.5	
t_{PLH}	Any D	Y		8		12	ns
t_{PHL}				8		12	
t_{PLH}	Any D	W		4.5		7	ns
t_{PHL}				4.5		7	
t_{PLH}	Strobe \bar{G}	Y			11	16.5	ns
t_{PHL}					12	18	
t_{PLH}	Strobe \bar{G}	W			9	13	ns
t_{PHL}					8.5	12	

¶ t_{PLH} ≡ Propagation delay time, low-to-high-level output

t_{PHL} ≡ Propagation delay time, high-to-low-level output

NOTE 4: See General Information Section for load circuits and voltage waveforms.

**TYPES SN54153, SN54L153, SN54LS153, SN54S153
 SN74153, SN74L153, SN74S153
 DUAL 4-LINE TO 1-LINE DATA SELECTORS/MULTIPLEXERS**

logic symbol

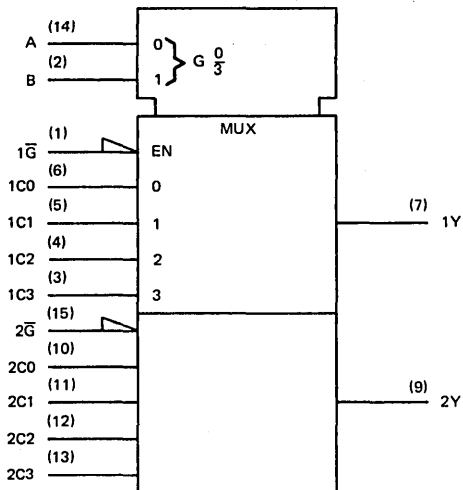

logic diagram

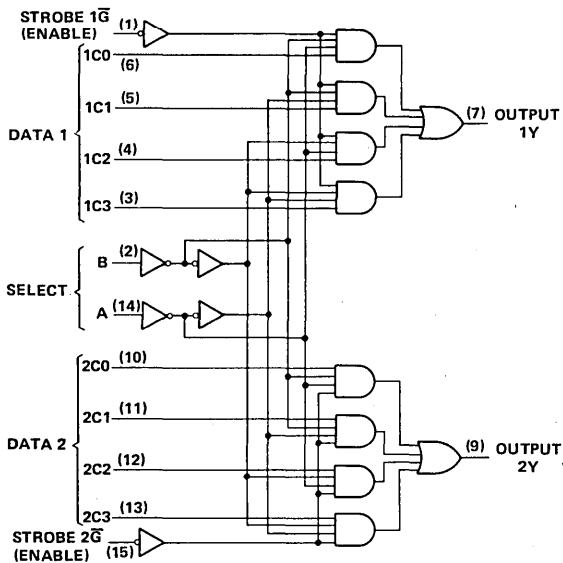

Pin numbers shown on logic notation are for D, J or N packages.

TYPES SN54153, SN54L153, SN54LS153, SN54S153
 SN74153, SN74LS153, SN74S153
 DUAL 4-LINE TO 1-LINE DATA SELECTORS/MULTIPLEXERS

schematics of inputs and outputs

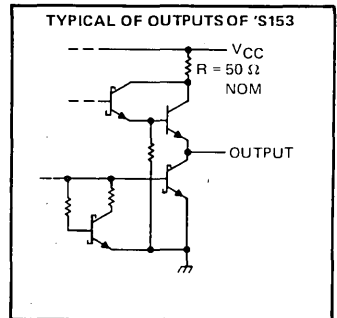
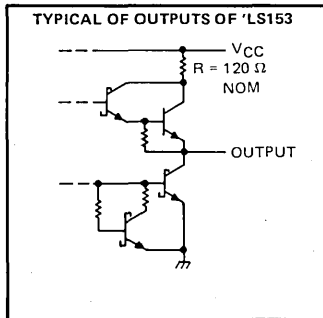
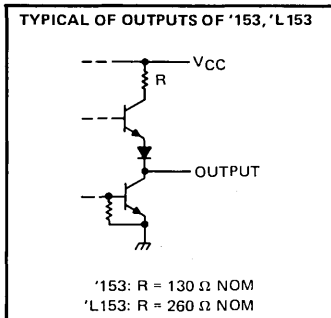
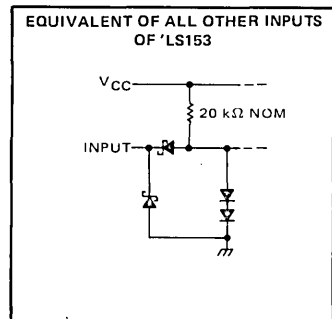
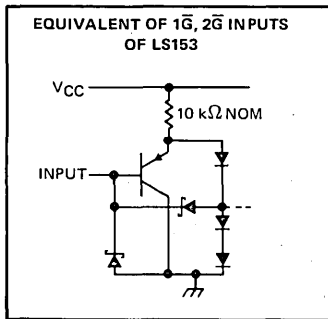
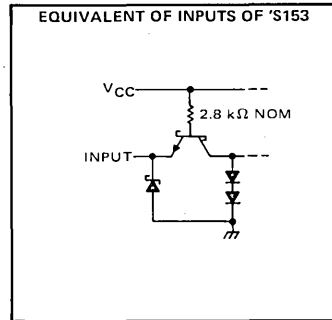
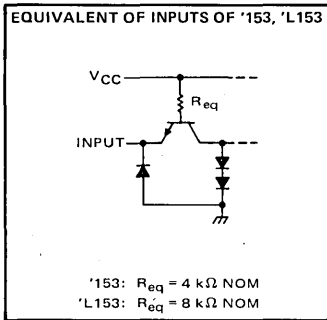

TTL DEVICES

TYPES SN54153, SN74153 DUAL 4-LINE TO 1-LINE DATA SELECTORS/MULTIPLEXERS

recommended operating conditions

	SN54153			SN74153			UNIT
	MIN	NOM	MAX	MIN	NOM	MAX	
Supply voltage, V_{CC}	4.5	5	5.5	4.75	5	5.25	V
High-level output current, I_{OH}	-800			-800			μ A
Low-level output current, I_{OL}	16			16			mA
Operating free-air temperature, T_A	-55			0			70 °C

electrical characteristics over recommended operating free-air temperature range (unless otherwise noted)

PARAMETER	TEST CONDITIONS†	SN54153			SN74153			UNIT
		MIN	TYP‡	MAX	MIN	TYP‡	MAX	
V_{IH} High-level input voltage		2			2			V
V_{IL} Low-level input voltage		0.8			0.8			V
V_{IK} Input clamp voltage	$V_{CC} = \text{MIN}, I_I = -12 \text{ mA}$	-1.5			-1.5			V
V_{OH} High-level output voltage	$V_{CC} = \text{MIN}, V_{IH} = 2 \text{ V}, V_{IL} = 0.8 \text{ V}, I_{OH} = -800 \mu\text{A}$	2.4	3.4		2.4	3.4	V	
V_{OL} Low-level output voltage	$V_{CC} = \text{MIN}, V_{IH} = 2 \text{ V}, V_{IL} = 0.8 \text{ V}, I_{OL} = 16 \text{ mA}$	0.2	0.4		0.2	0.4	V	
I_I Input current at maximum input voltage	$V_{CC} = \text{MAX}, V_I = 5.5 \text{ V}$	1			1			mA
I_{IH} High-level input current	$V_{CC} = \text{MAX}, V_I = 2.4 \text{ V}$	40			40			μ A
I_{IL} Low-level input current	$V_{CC} = \text{MAX}, V_I = 0.4 \text{ V}$	-1.6			-1.6			mA
I_{OS} Short-circuit output current§	$V_{CC} = \text{MAX}$	-20	-55		-18	-57	mA	
I_{CCL} Supply current, output low	$V_{CC} = \text{MAX}$, See Note 2	36	52		36	60	mA	

†For conditions shown as MIN or MAX, use the appropriate value specified under recommended operating conditions.

‡All typical values are at $V_{CC} = 5 \text{ V}, T_A = 25^\circ \text{C}$.

§Not more than one output should be shorted at a time.

NOTE 2: I_{CCL} is measured with the outputs open and all inputs grounded.

switching characteristics, $V_{CC} = 5 \text{ V}, T_A = 25^\circ \text{C}$

PARAMETER¶	FROM (INPUT)	TO (OUTPUT)	TEST CONDITIONS	MIN	TYP	MAX	UNIT
t_{PLH}	Data	Y	$C_L = 30 \text{ pF}, R_L = 400 \Omega,$ See Note 3	12	18		ns
t_{PHL}	Data	Y		15	23		ns
t_{PLH}	Select	Y		22	34		ns
t_{PHL}	Select	Y		22	34		ns
t_{PLH}	Strobe \bar{G}	Y		19	30		ns
t_{PHL}	Strobe \bar{G}	Y		15	23		ns

¶ t_{PLH} = propagation delay time, low-to-high-level output

t_{PHL} = propagation delay time, high-to-low-level output

NOTE 3: See General Information Section for load circuits and voltage waveforms.

3

TTL DEVICES

TYPE SN54L153

DUAL 4-LINE TO 1-LINE DATA SELECTORS/MULTIPLEXERS

recommended operating conditions

	MIN	NOM	MAX	UNIT
V _{CC} Supply voltage	4.5	5	5.5	V
V _{IH} High-level input voltage	2			V
V _{IL} Low-level input voltage	0.8			V
I _{OH} High-level output current	-0.4			mA
I _{OL} Low-level output current	8			mA
T _A Operating free-air temperature	-55		125	°C

electrical characteristics over recommended operating free-air temperature range (unless otherwise noted)

PARAMETER	TEST CONDITIONS †	MIN	TYP ‡	MAX	UNIT
V _{IK}	V _{CC} = MIN, I _I = -12 mA			-1.5	V
V _{OH}	V _{CC} = MIN, V _{IH} = 2 V, V _{IL} = 0.8 V, I _{OH} = -0.4 mA	2.4	3.4		V
V _{OL}	V _{CC} = MIN, V _{IH} = 2 V, V _{IL} = 0.8 V, I _{OL} = 8 mA		0.2	0.4	V
I _I	V _{CC} = MAX, V _I = 5.5 V			1	mA
I _{IH}	V _{CC} = MAX, V _I = 2.4 V			20	µA
I _{IL}	V _{CC} = MAX, V _I = 0.4 V			-0.8	mA
I _{OS} §	V _{CC} = MAX	-10		-28	mA
I _{CCL}	V _{CC} = MAX, See Note 2		18	26	mA

† For conditions shown as MIN or MAX, use the appropriate value specified under recommended operating conditions.

‡ All typical values are at V_{CC} = 5 V, T_A = 25°C.

§ Not more than one output should be shorted at a time and duration of short-circuit should not exceed one second.

NOTE 2: I_{CCL} is measured with the outputs open and all inputs grounded.

switching characteristics, V_{CC} = 5 V, T_A = 25°C

PARAMETER ¶	FROM INPUT	TO OUTPUT	TEST CONDITIONS	MIN	TYP	MAX	UNIT
t _{PLH}	Data	Y	C _L = 30 pF, R _L = 400 Ω, See Note 3	24	36	ns	
t _{PHL}	Data	Y		30	46	ns	
t _{PLH}	Select	Y		44	68	ns	
t _{PHL}	Select	Y		44	68	ns	
t _{PLH}	Strobe \bar{G}	Y		38	60	ns	
t _{PHL}	Strobe \bar{G}	Y		30	46	ns	

¶ t_{PLH} = propagation delay time, low-to-high-level output

t_{PHL} = propagation delay time, high-to-low-level output

NOTE 3: See General Information Section for load circuits and voltage waveforms.



TTL DEVICES

TYPES SN54LS153, SN74LS153 DUAL 4-LINE TO 1-LINE DATA SELECTORS/MULTIPLEXERS

recommended operating conditions

		SN54LS153			SN74LS153			UNIT
		MIN	NOM	MAX	MIN	NOM	MAX	
V _{CC}	Supply voltage	4.5	5	5.5	4.75	5	5.25	V
V _{IH}	High-level input voltage	2			2			V
V _{IL}	Low-level input voltage	0.7			0.8			V
I _{OH}	High-level output current	-0.4			-0.4			mA
I _{OL}	Low-level output current	4			8			mA
T _A	Operating free-air temperature	-55			125			°C

electrical characteristics over recommended operating free-air temperature range (unless otherwise noted)

PARAMETER	TEST CONDITIONS †	SN54LS153		SN74LS153		UNIT	
		MIN	TYP ‡	MAX	MIN		TYP ‡
V _{IK}	V _{CC} = MIN, I _I = -18 mA	-1.5		-1.5		V	
V _{OH}	V _{CC} = MIN, V _{IH} = 2 V, V _{IL} = MAX I _{OH} = -0.4 mA	2.5	3.4	2.7	3.4	V	
V _{OL}	V _{CC} = MIN, V _{IH} = 2 V, V _{IL} = MAX,	I _{OL} = 4 mA	0.25	0.4	0.25	0.4	V
		I _{OL} = 8 mA	0.35		0.5		
I _I	V _{CC} = MAX, V _I = 7 V	0.1		0.1		mA	
I _{IH}	V _{CC} = MAX, V _I = 2.7 V	20		20		μA	
I _{IL}	1G, 2G	-0.2		-0.2		mA	
	All other	-0.4		-0.4			
I _{OS} §	V _{CC} = MAX	-20	-100	-20	-100	mA	
I _{CCL}	V _{CC} = MAX, See Note 2	6.2	10	6.2	10	mA	

† For conditions shown as MIN or MAX, use the appropriate value specified under recommended operating conditions.

‡ All typical values are at V_{CC} = 5 V, T_A = 25°C.

§ Not more than one output should be shorted at a time.

NOTE 2: I_{CCL} is measured with the outputs open and all inputs grounded.

switching characteristics, V_{CC} = 5 V, T_A = 25°C

PARAMETER ¶	FROM (INPUT)	TO (OUTPUT)	TEST CONDITIONS	MIN	TYP	MAX	UNIT
t _{PLH}	Data	Y	C _L = 15 pF, R _L = 2 kΩ, See Note 3	10	15	ns	
t _{PHL}	Data	Y		17	26	ns	
t _{PLH}	Select	Y		19	29	ns	
t _{PHL}	Select	Y		25	38	ns	
t _{PLH}	Strobe \bar{G}	Y		16	24	ns	
t _{PHL}	Strobe \bar{G}	Y		21	32	ns	

¶ t_{PLH} = propagation delay time, low-to-high-level output

t_{PHL} = propagation delay time, high-to-low-level output

NOTE 3: See General Information Section for load circuits and voltage waveforms.

3

TTL DEVICES

TYPES SN54S153, SN74S153 DUAL 4-LINE TO 1-LINE DATA SELECTORS/MULTIPLEXERS

recommended operating conditions

	SN54S153			SN74S153			UNIT
	MIN	NOM	MAX	MIN	NOM	MAX	
Supply voltage, V_{CC}	4.5	5	5.5	4.75	5	5.25	V
High-level output current, I_{OH}			-1			-1	mA
Low-level output current, I_{OL}			20			20	mA
Operating free-air temperature, T_A	-55		125	0		70	°C

electrical characteristics over recommended operating free-air temperature range (unless otherwise noted)

PARAMETER	TEST CONDITIONS†	MIN	TYP‡	MAX	UNIT
V_{IH} High-level input voltage		2			V
V_{IL} Low-level input voltage				0.8	V
V_{IK} Input clamp voltage	$V_{CC} = \text{MIN}, I_I = -18 \text{ mA}$			-1.2	V
V_{OH} High-level output voltage	$V_{CC} = \text{MIN}, V_{IH} = 2 \text{ V},$ $V_{IL} = 0.8 \text{ V}, I_{OH} = -1 \text{ mA}$	Series 54S 2.5	Series 74S 3.4		V
V_{OL} Low-level output voltage	$V_{CC} = \text{MIN}, V_{IH} = 2 \text{ V},$ $V_{IL} = 0.8 \text{ V}, I_{OL} = 20 \text{ mA}$			0.5	V
I_I Input current at maximum input voltage	$V_{CC} = \text{MAX}, V_I = 5.5 \text{ V}$			1	mA
I_{IH} High-level input current	$V_{CC} = \text{MAX}, V_I = 2.7 \text{ V}$			50	µA
I_{IL} Low-level input current	$V_{CC} = \text{MAX}, V_I = 0.5 \text{ V}$			-2	mA
I_{OS} Short-circuit output current§	$V_{CC} = \text{MAX}$	-40		-100	mA
I_{CCL} Supply current, low-level output	$V_{CC} = \text{MAX}, \text{ See Note 2}$		45	70	mA

† For conditions shown as MIN or MAX, use the appropriate value specified under recommended operating conditions.

‡ All typical values are at $V_{CC} = 5 \text{ V}, T_A = 25^\circ\text{C}$.

§ Not more than one output should be shorted at a time and duration of short-circuit should not exceed one second.

NOTE 2: I_{CCL} is measured with the outputs open and all inputs grounded.

switching characteristics, $V_{CC} = 5 \text{ V}, T_A = 25^\circ\text{C}$

PARAMETER ¶	FROM (INPUT)	TO (OUTPUT)	TEST CONDITIONS	MIN	TYP	MAX	UNIT
t_{PLH}	Data	Y	$C_L = 15 \text{ pF}, R_L = 280 \Omega,$ See Note 3		6	9	ns
t_{PHL}	Data	Y			6	9	ns
t_{PLH}	Select	Y			11.5	18	ns
t_{PHL}	Select	Y			12	18	ns
t_{PLH}	Strobe \overline{G}	Y			10	15	ns
t_{PHL}	Strobe \overline{G}	Y			9	13.5	ns

¶ t_{PLH} = propagation delay time, low-to-high-level output

t_{PHL} = propagation delay time, high-to-low-level output

NOTE 3: See General Information Section for load circuits and voltage waveforms.

TYPES SN54154, SN54L154, SN74154 4-LINE TO 16-LINE DECODERS/DEMULTIPLEXERS

DECEMBER 1972—REVISED DECEMBER 1983

- '154 is Ideal for High-Performance Memory Decoding
- 'L154 is Designed for Power-Critical Applications
- Decodes 4 Binary-Coded Inputs into One of 16 Mutually Exclusive Outputs
- Performs the Demultiplexing Function by Distributing Data From One Input Line to Any One of 16 Outputs
- Input Clamping Diodes Simplify System Design
- High Fan-Out, Low-Impedance, Totem-Pole Outputs
- Fully Compatible with Most TTL and MSI Circuits

SN54154 . . . J OR W PACKAGE
SN54L154 . . . J PACKAGE
SN74154 . . . J OR N PACKAGE

(TOP VIEW)

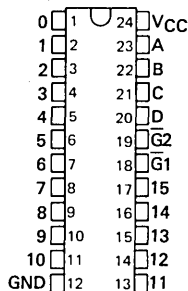

TYPE	TYPICAL AVERAGE PROPAGATION DELAY		TYPICAL POWER DISSIPATION
	3 LEVELS OF LOGIC	STROBE	
'154	23 ns	19 ns	170 mW
'L154	46 ns	38 ns	85 mW

description

Each of these monolithic, 4-line-to-16-line decoders utilizes TTL circuitry to decode four binary-coded inputs into one of sixteen mutually exclusive outputs when both the strobe inputs, $\overline{G1}$ and $\overline{G2}$, are low. The demultiplexing function is performed by using the 4 input lines to address the output line, passing data from one of the strobe inputs with the other strobe input low. When either strobe input is high, all outputs are high. These demultiplexers are ideally suited for implementing high-performance memory decoders. For ultra-high speed systems, SN54S138/SN74S138 and SN54S139/SN74S139 are recommended.

These circuits are fully compatible for use with most other TTL circuits. All inputs are buffered and input clamping diodes are provided to minimize transmission-line effects and thereby simplify system design.

The SN54154 and SN54L154 are characterized for operation over the full military temperature range of -55°C to 125°C . The SN74154 is characterized for operation from 0°C to 70°C .

logic symbol

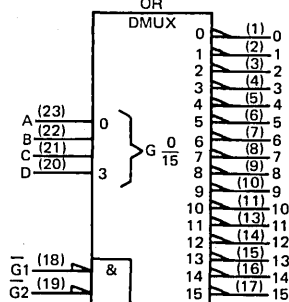
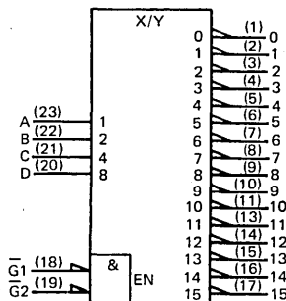

Pin numbers shown on logic notation are for J or N packages.

PRODUCTION DATA
This document contains information current as of publication date. Products conform to specifications per the terms of Texas Instruments standard warranty. Production processing does not necessarily include testing of all parameters.

TEXAS INSTRUMENTS

POST OFFICE BOX 225012 • DALLAS, TEXAS 75265

3-577

3
TTL DEVICES

TYPES SN54154, SN54L154, SN74154
4-LINE TO 16-LINE DECODERS/DEMULTIPLEXERS

FUNCTION TABLE

INPUTS		OUTPUTS																				
G1	G2	D	C	B	A	0	1	2	3	4	5	6	7	8	9	10	11	12	13	14	15	
L	L	L	L	L	L	L	H	H	H	H	H	H	H	H	H	H	H	H	H	H	H	H
L	L	L	L	L	H	H	L	H	H	H	H	H	H	H	H	H	H	H	H	H	H	H
L	L	L	L	H	L	H	H	L	H	H	H	H	H	H	H	H	H	H	H	H	H	H
L	L	L	L	H	H	H	H	H	L	H	H	H	H	H	H	H	H	H	H	H	H	H
L	L	L	H	L	L	H	H	H	H	H	L	H	H	H	H	H	H	H	H	H	H	H
L	L	L	H	H	L	H	H	H	H	H	H	L	H	H	H	H	H	H	H	H	H	H
L	L	L	H	H	H	H	H	H	H	H	H	H	L	H	H	H	H	H	H	H	H	H
L	L	H	L	L	L	H	H	H	H	H	H	H	H	L	H	H	H	H	H	H	H	H
L	L	H	L	L	H	H	H	H	H	H	H	H	H	H	L	H	H	H	H	H	H	H
L	L	H	L	H	L	H	H	H	H	H	H	H	H	H	H	L	H	H	H	H	H	H
L	L	H	H	L	L	H	H	H	H	H	H	H	H	H	H	H	H	H	H	L	H	H
L	L	H	H	L	H	H	H	H	H	H	H	H	H	H	H	H	H	H	H	H	L	H
L	L	H	H	H	L	H	H	H	H	H	H	H	H	H	H	H	H	H	H	H	H	L
L	H	X	X	X	X	H	H	H	H	H	H	H	H	H	H	H	H	H	H	H	H	H
H	L	X	X	X	X	H	H	H	H	H	H	H	H	H	H	H	H	H	H	H	H	H
H	H	X	X	X	X	H	H	H	H	H	H	H	H	H	H	H	H	H	H	H	H	H

H = high level, L = low level, X = irrelevant

3 TTL DEVICES

schematics of inputs and outputs

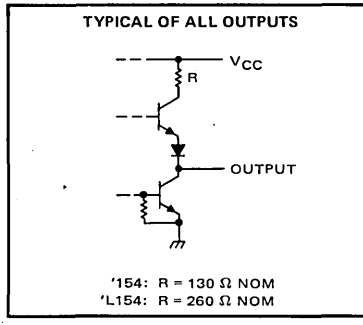
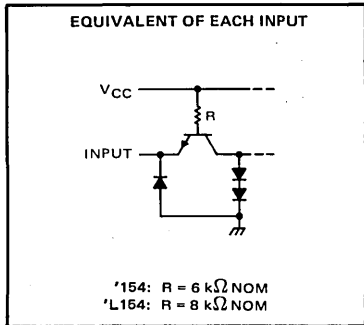

TYPES SN54154, SN54L154, SN74154
4-LINE TO 16-LINE DECODERS/DEMULTIPLEXERS

logic diagram

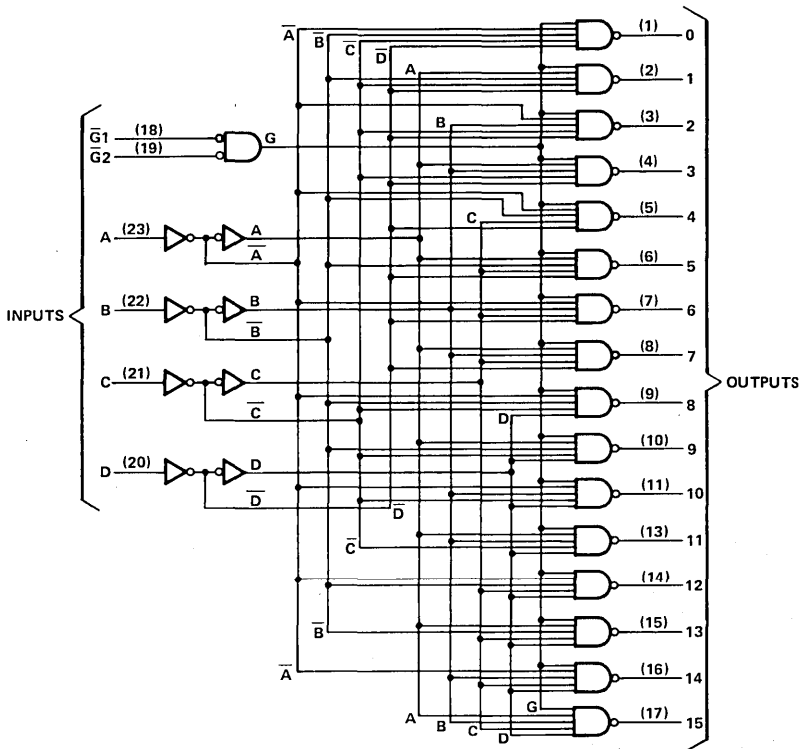

Pin numbers shown on logic notation are for J or N packages.

3
TTL DEVICES

TYPES SN54154, SN74154

4-LINE TO 16-LINE DECODERS/DEMULTIPLEXERS

absolute maximum ratings over operating free-air temperature range (unless otherwise noted)

Supply voltage, V_{CC} (see Note 1)	7 V
Input voltage	5.5 V
Operating free-air temperature range: SN54154 Circuits	-55°C to 125°C
SN74154 Circuits	0°C to 70°C
Storage temperature range	-65°C to 150°C

NOTE 1: Voltage values are with respect to network ground terminal.

recommended operating conditions

	SN54154			SN74154			UNIT
	MIN	NOM	MAX	MIN	NOM	MAX	
Supply voltage, V_{CC}	4.5	5	5.5	4.75	5	5.25	V
High-level output current, I_{OH}			-800			-800	μ A
Low-level output current, I_{OL}			16			16	mA
Operating free-air temperature, T_A	-55		125	0		70	°C

electrical characteristics over recommended operating free-air temperature range (unless otherwise noted)

PARAMETER	TEST CONDITIONS†	SN54154			SN74154			UNIT
		MIN	TYP	MAX	MIN	TYP‡	MAX	
V_{IH} High-level input voltage		2			2			V
V_{IL} Low-level input voltage				0.8			0.8	V
V_{IK} Input clamp voltage	$V_{CC} = \text{MIN}$, $I_I = -12 \text{ mA}$			-1.5			-1.5	V
V_{OH} High-level output voltage	$V_{CC} = \text{MIN}$, $V_{IH} = 2 \text{ V}$, $V_{IL} = 0.8 \text{ V}$, $I_{OH} = -800 \mu\text{A}$	2.4	3.4		2.4	3.4		V
V_{OL} Low-level output voltage	$V_{CC} = \text{MIN}$, $V_{IH} = 2 \text{ V}$, $V_{IL} = 0.8 \text{ V}$, $I_{OL} = 16 \text{ mA}$		0.2	0.4		0.2	0.4	V
I_I Input current at maximum input voltage	$V_{CC} = \text{MAX}$, $V_I = 5.5 \text{ V}$			1			1	mA
I_{IH} High-level input current	$V_{CC} = \text{MAX}$, $V_I = 2.4 \text{ V}$			40			40	μ A
I_{IL} Low-level input current	$V_{CC} = \text{MAX}$, $V_I = 0.4 \text{ V}$			-1.6			-1.6	mA
I_{OS} Short-circuit output current§	$V_{CC} = \text{MAX}$			-20			-57	mA
I_{CC} Supply current	$V_{CC} = \text{MAX}$, See Note 2			34			49	mA

† For conditions shown as MIN or MAX, use the appropriate value specified under recommended operating conditions for the applicable type.

‡ All typical values are at $V_{CC} = 5 \text{ V}$, $T_A = 25^\circ \text{C}$.

§ Not more than one output should be shorted at a time.

NOTE 2: I_{CC} is measured with all inputs grounded and all outputs open.

switching characteristics, $V_{CC} = 5 \text{ V}$, $T_A = 25^\circ \text{C}$

PARAMETER	TEST CONDITIONS	MIN	TYP	MAX	UNIT
t_{PLH} Propagation delay time, low-to-high-level output, from A, B, C, or D inputs through 3 levels of logic	$C_L = 15 \text{ pF}$, $R_L = 400 \Omega$, See Note 3		24	36	ns
t_{PHL} Propagation delay time, high-to-low-level output, from A, B, C, or D inputs through 3 levels of logic			22	33	ns
t_{PLH} Propagation delay time, low-to-high-level output, from either strobe input			20	30	ns
t_{PHL} Propagation delay time, high-to-low-level output, from either strobe input			18	27	ns

NOTE 3: See General Information Section for load circuits and voltage waveforms.

3

TTL DEVICES

TYPE SN54L154 4-LINE TO 16-LINE DECODER/DEMULTIPLEXER

absolute maximum ratings over operating free-air temperature range (unless otherwise noted)

Supply voltage, V_{CC} (see Note 1)	7 V
Input voltage	5.5 V
Operating free-air temperature	-55°C to 125°C
Storage temperature range	-65°C to 150°C

NOTE 1: Voltage values are with respect to network ground terminal.

recommended operating conditions

	SN54L154			UNIT
	MIN	NOM	MAX	
V_{CC} Supply voltage	4.5	5	5.5	V
V_{IH} High-level input voltage	2			V
V_{IL} Low-level input voltage	0.8			V
I_{OH} High-level output current	-0.4			mA
I_{OL} Low-level output current	8			mA
T_A Operating free-air temperature	-55	125		°C

electrical characteristics over recommended operating free-air temperature range (unless otherwise noted)

PARAMETER	TEST CONDITIONS†	SN54L154			UNIT	
		MIN	TYP‡	MAX		
V_{IK}	$V_{CC} = \text{MIN}, I_I = -12 \text{ mA}$	-1.5			V	
V_{OH}	$V_{CC} = \text{MIN}, V_{IH} = 2 \text{ V}, V_{IL} = 0.8 \text{ V}, I_{OH} = -0.4 \text{ mA}$	2.4	3.4		V	
V_{OL}	$V_{CC} = \text{MIN}, V_{IH} = 2 \text{ V}, V_{IL} = 0.8 \text{ V}, I_{OL} = 8 \text{ mA}$	0.2	0.4		V	
I_I	$V_{CC} = \text{MAX}, V_I = 5.5 \text{ V}$	1			mA	
I_{IH}	$V_{CC} = \text{MAX}, V_I = 2.4 \text{ V}$	20			µA	
I_{IL}	$V_{CC} = \text{MAX}, V_I = 0.4 \text{ V}$	-0.8			mA	
$I_{OS}\$$	$V_{CC} = \text{MAX}$	-9	-29		mA	
I_{CC}	$V_{CC} = \text{MAX},$ See Note 2	17			25	mA

† For conditions shown as MIN or MAX, use the appropriate value specified under recommended operating conditions.

‡ All typical values are at $V_{CC} = 5 \text{ V}, T_A = 25^\circ\text{C}$.

§ Not more than one output should be shorted at a time.

NOTE 2: I_{CC} is measured with all outputs open and all inputs grounded.

switching characteristics, $V_{CC} = 5 \text{ V}, T_A = 25^\circ\text{C}$ (see note 3)

PARAMETER	FROM (INPUT)	TO (OUTPUT)	TEST CONDITIONS	MIN	TYP	MAX	UNIT
t_{PLH}	A, B, C, D	Any	$R_L = 800 \Omega, C_L = 15 \text{ pF}$	48	72		ns
t_{PHL}				44	66		ns
t_{PLH}	Strobe			40	60		ns
t_{PHL}				36	54		ns

NOTE 3: See General Information Section for load circuits and voltage waveforms.

TYPES SN54155, SN54156, SN54LS155A, SN54LS156, SN74155, SN74156, SN74LS155A, SN74LS156 DUAL 2-LINE TO 4-LINE DECODERS/DEMULTIPLEXERS

MARCH 1974—REVISED DECEMBER 1983

- **Applications:**
Dual 2-to 4-Line Decoder
Dual 1-to 4-Line Demultiplexer
3-to 8-Line Decoder
1-to 8-Line Demultiplexer
- **Individual Strobes Simplify Cascading for Decoding or Demultiplexing Larger Words**
- **Input Clamping Diodes Simplify System Design**
- **Choice of Outputs:**
Totem Pole ('155, 'LS155A)
Open-Collector ('156, 'LS156)

SN54155, SN54156, SN54LS155A, SN54LS156 . . . J OR W PACKAGE
SN74155, SN74156 . . . J OR N PACKAGE
SN74LS155A, SN74LS156 . . . D, J OR N PACKAGE
(TOP VIEW)

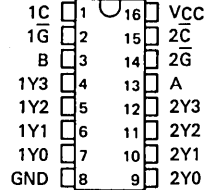

TYPES	TYPICAL AVERAGE PROPAGATION DELAY 3 GATE LEVELS	TYPICAL POWER DISSIPATION
'155, '156	21 ns	125 mW
'LS155A	18 ns	31 mW
'LS156	32 ns	31 mW

SN54LS155A, SN54LS156 . . . FK PACKAGE
SN74LS155A, SN74LS156 . . . FN PACKAGE
(TOP VIEW)

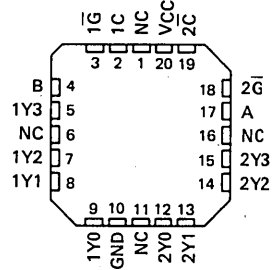

description

These monolithic transistor-transistor-logic (TTL) circuits feature dual 1-line-to-4-line demultiplexers with individual strobes and common binary-address inputs in a single 16-pin package. When both sections are enabled by the strobes, the common binary-address inputs sequentially select and route associated input data to the appropriate output of each section. The individual strobes permit activating or inhibiting each of the 4-bit sections as desired. Data applied to input 1C is inverted at its outputs and data applied at 2C is not inverted through its outputs. The inverter following the 1C data input permits use as a 3-to-8-line decoder or 1-to-8-line demultiplexer without external gating. Input clamping diodes are provided on all of these circuits to minimize transmission-line effects and simplify system design.

Series 54 and 54LS are characterized for operation over the full military temperature range of -55°C to 125°C ; Series 74 and 74LS are characterized for operation from 0°C to 70°C .

schematics of inputs and outputs

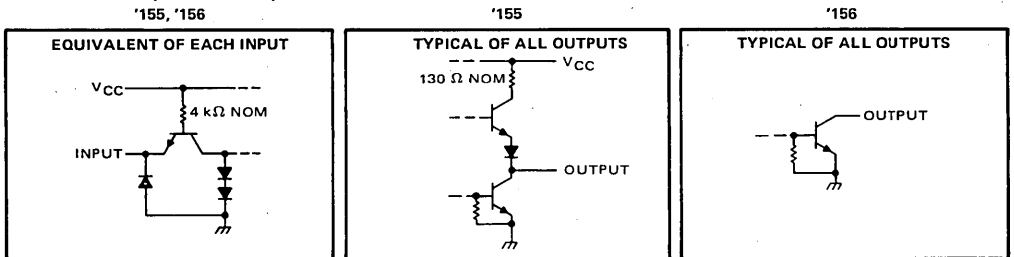

PRODUCTION DATA
This document contains information current as of publication date. Products conform to specifications per the terms of Texas Instruments standard warranty. Production processing does not necessarily include testing of all parameters.

TEXAS INSTRUMENTS

POST OFFICE BOX 225012 • DALLAS, TEXAS 75265

3

TTL DEVICES

TYPES SN54155, SN54156, SN54LS155A, SN54LS156, SN74155, SN74156, SN74LS155A, SN74LS156 DUAL 2-LINE TO 4-LINE DECODERS/DEMULTIPLEXERS

schematics of inputs and outputs (continued)

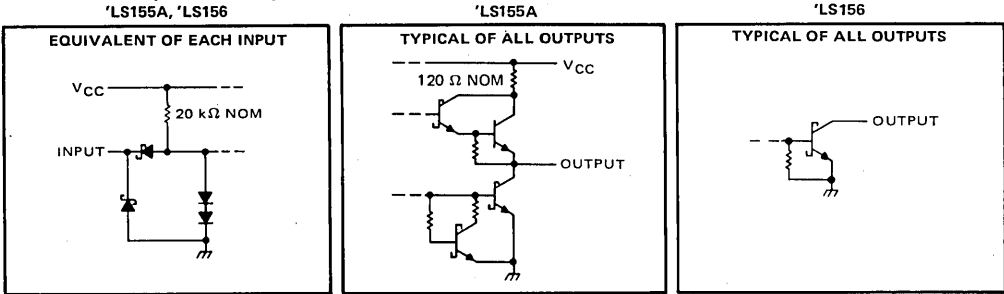

logic diagram

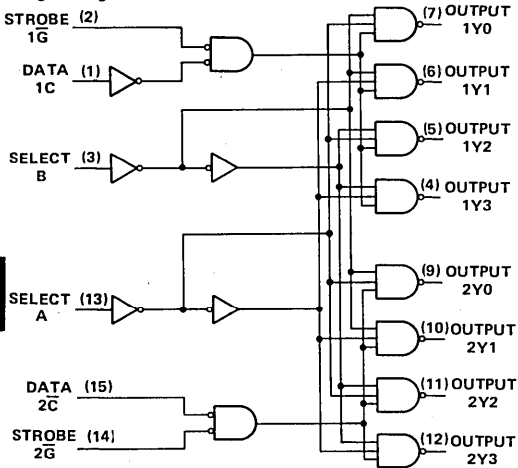

FUNCTION TABLES
2-LINE-TO-4-LINE DECODER
OR 1-LINE-TO-4-LINE DEMULTIPLEXER

INPUTS				OUTPUTS			
SELECT	STROBE	DATA		1Y0	1Y1	1Y2	1Y3
B	A	1G	1C				
X	X	H	X	H	H	H	H
L	L	L	H	L	H	H	H
L	H	L	H	H	L	H	H
H	L	L	H	H	H	L	H
H	H	L	H	H	H	H	L
X	X	X	L	H	H	H	H

INPUTS				OUTPUTS			
SELECT	STROBE	DATA		2Y0	2Y1	2Y2	2Y3
B	A	2G	2C				
X	X	H	X	H	H	H	H
L	L	L	L	L	H	H	H
L	H	L	L	H	L	H	H
H	L	L	L	H	H	L	H
H	H	L	L	H	H	H	L
X	X	X	H	H	H	H	H

logic symbol

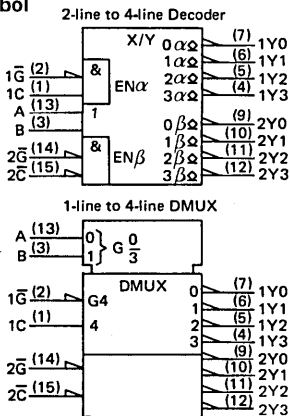

FUNCTION TABLE
3-LINE-TO-8-LINE DECODER
OR 1-LINE-TO-8-LINE DEMULTIPLEXER

INPUTS				OUTPUTS							
SELECT	STROBE	OR DATA		(0)	(1)	(2)	(3)	(4)	(5)	(6)	(7)
C†	B	A	G‡	2Y0	2Y1	2Y2	2Y3	1Y0	1Y1	1Y2	1Y3
X	X	X	H	H	H	H	H	H	H	H	H
L	L	L	L	L	H	H	H	H	H	H	H
L	L	H	L	H	L	H	H	H	H	H	H
L	H	L	L	H	H	L	H	H	H	H	H
L	H	H	L	H	H	H	L	H	H	H	H
H	L	L	L	H	H	H	H	L	H	H	H
H	L	H	L	H	H	H	H	H	L	H	H
H	H	L	L	H	H	H	H	H	H	L	H
H	H	H	L	H	H	H	H	H	H	H	L

†C = inputs 1C and 2C connected together

‡G = inputs 1G and 2G connected together

H = high level, L = low level, X = irrelevant

Pin numbers shown on logic notation are for D, J or N packages.

TYPES SN54156, SN74156 DUAL 2-LINE TO 4-LINE DECODERS/DEMULTIPLEXERS

recommended operating conditions

	SN54156			SN74156			UNIT
	MIN	NOM	MAX	MIN	NOM	MAX	
Supply voltage, V_{CC}	4.5	5	5.5	4.75	5	5.25	V
High-level output voltage, V_{OH}				5.5			V
Low-level output current, I_{OL}				16			mA
Operating free-air temperature, T_A	-55			125			0 70 °C

electrical characteristics over recommended operating free-air temperature range (unless otherwise noted)

PARAMETER	TEST CONDITIONS†	SN54156 SN74156		UNIT	
		MIN	TYP‡		MAX
V_{IH} High-level input voltage		2		V	
V_{IL} Low-level input voltage				0.8 V	
V_{IK} Input clamp voltage	$V_{CC} = \text{MIN}, I_I = -8 \text{ mA}$			-1.5 V	
I_{OH} High-level output current	$V_{CC} = \text{MIN}, V_{IH} = 2 \text{ V}, V_{IL} = 0.8 \text{ V}, V_{OH} = 5.5 \text{ V}$			250 μA	
V_{OL} Low-level output voltage	$V_{CC} = \text{MIN}, V_{IH} = 2 \text{ V}, V_{IL} = 0.8 \text{ V}, I_{OL} = 16 \text{ mA}$	0.2	0.4	V	
I_I Input current at maximum input voltage	$V_{CC} = \text{MAX}, V_I = 5.5 \text{ V}$			1 mA	
I_{IH} High-level input current	$V_{CC} = \text{MAX}, V_I = 2.4 \text{ V}$			40 μA	
I_{IL} Low-level input current	$V_{CC} = \text{MAX}, V_I = 0.4 \text{ V}$			-1.6 mA	
I_{CC} Supply current	$V_{CC} = \text{MAX},$ See Note 2	SN54156	25	35	mA
		SN74156	25	40	

†For conditions shown as MIN or MAX, use the appropriate value specified under recommended operating conditions.

‡All typical values are at $V_{CC} = 5 \text{ V}, T_A = 25^\circ\text{C}$.

NOTE 2: I_{CC} is measured with outputs open, A, B, and 1C inputs at 4.5 V, and 2C, 1G, and 2G inputs grounded.

switching characteristics, $V_{CC} = 5 \text{ V}, T_A = 25^\circ\text{C}$

PARAMETER¶	FROM (INPUT)	TO (OUTPUT)	LEVELS OF LOGIC	TEST CONDITIONS	MIN	TYP	MAX	UNIT
t_{PLH}	A, B, 2C, 1G, or 2G	Y	2	$C_L = 15 \text{ pF},$ $R_L = 400 \Omega,$ See Note 3		15	23	ns
t_{PHL}	A, B, 2C, 1G, or 2G	Y	2		20	30	ns	
t_{PLH}	A or B	Y	3		23	34	ns	
t_{PHL}	A or B	Y	3		23	34	ns	
t_{PLH}	1C	Y	3		18	27	ns	
t_{PHL}	1C	Y	3		22	33	ns	

¶ t_{PLH} = propagation delay time, low-to-high-level output

t_{PHL} = propagation delay time, high-to-low-level output

NOTE 3: See General Information Section for load circuits and voltage waveforms.

3

TTL DEVICES

TYPES SN54LS155A, SN74LS155A DUAL 2-LINE TO 4-LINE DECODERS/DEMULTIPLEXERS

recommended operating conditions

	SN54LS155A			SN74LS155A			UNIT
	MIN	NOM	MAX	MIN	NOM	MAX	
Supply voltage, V_{CC}	4.5	5	5.5	4.75	5	5.25	V
High-level output current, I_{OH}	-400			-400			μ A
Low-level output current, I_{OL}	4			8			mA
Operating free-air temperature, T_A	-55	125		0	70		$^{\circ}$ C

electrical characteristics over recommended operating free-air temperature range (unless otherwise noted)

PARAMETER	TEST CONDITIONS†	SN54LS155A		SN74LS155A		UNIT
		MIN	TYP‡	MAX	MIN	
V_{IH} High-level input voltage		2		2		V
V_{IL} Low-level input voltage				0.7		V
V_{IK} Input clamp voltage	$V_{CC} = \text{MIN}, I_I = -18 \text{ mA}$	-1.5		-1.5		V
V_{OH} High-level output voltage	$V_{CC} = \text{MIN}, V_{IH} = 2 \text{ V}, V_{IL} = V_{IL \text{ max}}, I_{OH} = -400 \mu\text{A}$	2.5	3.4	2.7	3.4	V
V_{OL} Low-level output voltage	$V_{CC} = \text{MIN}, V_{IH} = 2 \text{ V}, V_{IL} = V_{IL \text{ max}}$			0.25	0.4	V
				0.35	0.5	
I_I Input current at maximum input voltage	$V_{CC} = \text{MAX}, V_I = 7 \text{ V}$	0.1		0.1		mA
I_{IH} High-level input current	$V_{CC} = \text{MAX}, V_I = 2.7 \text{ V}$	20		20		μ A
I_{IL} Low-level input current	$V_{CC} = \text{MAX}, V_I = 0.4 \text{ V}$	-0.4		-0.4		mA
I_{OS} Short-circuit output current§	$V_{CC} = \text{MAX}$	-20	-100	-20	-100	mA
I_{CC} Supply current	$V_{CC} = \text{MAX},$ See Note 2	6.1	10	6.1	10	mA

† For conditions shown as MIN or MAX, use the appropriate value specified under recommended operating conditions.

‡ All typical values are at $V_{CC} = 5 \text{ V}, T_A = 25^{\circ}\text{C}$.

§ Not more than one output should be shorted at a time.

NOTE 2: I_{CC} is measured with outputs open, A, B, and 1C inputs at 4.5 V, and 2C, 1G, and 2G inputs grounded.

switching characteristics, $V_{CC} = 5 \text{ V}, T_A = 25^{\circ}\text{C}$

PARAMETER¶	FROM (INPUT)	TO (OUTPUT)	LEVELS OF LOGIC	TEST CONDITIONS	SN54LS155A SN74LS155A			UNIT
					MIN	TYP	MAX	
t_{PLH}	A, B, 2C, 1G, or 2G	Y	2	$C_L = 15 \text{ pF},$ $R_L = 2 \text{ k}\Omega,$ See Note 3	10	15	ns	
t_{PHL}	A, B, 2C, 1G, or 2G	Y	2		19	30	ns	
t_{PLH}	A or B	Y	3		17	26	ns	
t_{PHL}	A or B	Y	3		19	30	ns	
t_{PLH}	1C	Y	3		18	27	ns	
t_{PHL}	1C	Y	3		18	27	ns	

¶ t_{PLH} = propagation delay time, low-to-high-level output

t_{PHL} = propagation delay time, high-to-low-level output

NOTE 3: See General Information Section for load circuits and voltage waveforms.

3

TTL DEVICES

TYPES SN54LS156, SN74LS156

DUAL 2-LINE TO 4-LINE DECODERS/DEMULTIPLEXERS

recommended operating conditions

	SN54LS156			SN74LS156			UNIT
	MIN	NOM	MAX	MIN	NOM	MAX	
Supply voltage, V_{CC}	4.5	5	5.5	4.75	5	5.25	V
High-level output voltage, V_{OH}	5.5			5.5			V
Low-level output current, I_{OL}	4			8			mA
Operating free-air temperature, T_A	-55			125			$^{\circ}$ C

electrical characteristics over recommended operating free-air temperature range (unless otherwise noted)

PARAMETER	TEST CONDITIONS†	SN54LS156			SN74LS156			UNIT
		MIN	TYP‡	MAX	MIN	TYP‡	MAX	
V_{IH} High-level input voltage		2			2			V
V_{IL} Low-level input voltage		0.7			0.8			V
V_{IK} Input clamp voltage	$V_{CC} = \text{MIN}, I_I = -18 \text{ mA}$	-1.5			-1.5			V
I_{OH} High-level output current	$V_{CC} = \text{MIN}, V_{IH} = 2 \text{ V}, V_{IL} = V_{IL \text{ max}}, V_{OH} = 5.5 \text{ V}$	100			100			μ A
V_{OL} Low-level output voltage	$V_{CC} = \text{MIN}, V_{IH} = 2 \text{ V}, V_{IL} = V_{IL \text{ max}}$	$I_{OL} = 4 \text{ mA}$	0.25	0.4	0.25	0.4	V	
		$I_{OL} = 8 \text{ mA}$			0.35	0.5		
I_I Input current at maximum input voltage	$V_{CC} = \text{MAX}, V_I = 7 \text{ V}$	0.1			0.1			mA
I_{IH} High-level input current	$V_{CC} = \text{MAX}, V_I = 2.7 \text{ V}$	20			20			μ A
I_{IL} Low-level input current	$V_{CC} = \text{MAX}, V_I = 0.4 \text{ V}$	-0.4			-0.4			mA
I_{CC} Supply current	$V_{CC} = \text{MAX},$ See Note 2	6.1	10	6.1	10	mA		

†For conditions shown as MIN or MAX, use the appropriate value specified under recommended operating conditions.

‡All typical values are at $V_{CC} = 5 \text{ V}, T_A = 25^{\circ}\text{C}$.

NOTE 2: I_{CC} is measured with outputs open, A, B, and 1C inputs at 4.5 V, and 2C, 1C, and 2G inputs grounded.

switching characteristics, $V_{CC} = 5 \text{ V}, T_A = 25^{\circ}\text{C}$

PARAMETER¶	FROM (INPUT)	TO (OUTPUT)	LEVELS OF LOGIC	TEST CONDITIONS	SN54LS156 SN74LS156			UNIT
					MIN	TYP	MAX	
t_{PLH}	A, B, 2C 1G, or 2G	Y	2	$C_L = 15 \text{ pF},$ $R_L = 2 \text{ k}\Omega,$ See Note 3	25	40	ns	
t_{PHL}	A, B, 2C, 1G, or 2G	Y	2		34	51	ns	
t_{PLH}	A or B	Y	3		31	46	ns	
t_{PHL}	A or B	Y	3		34	51	ns	
t_{PLH}	1C	Y	3		32	48	ns	
t_{PHL}	1C	Y	3		32	48	ns	

¶ t_{PLH} = propagation delay time, low-to-high-level output

t_{PHL} = propagation delay time, high-to-low-level output

NOTE 3: See General Information Section for load circuits and voltage waveforms.

TYPES SN54157, SN54L157, SN54LS157, SN54LS158, SN54S157, SN54S158, SN74157, SN74L157, SN74LS157, SN74LS158, SN74S157, SN74S158 QUADRUPLE 2-LINE TO 1-LINE DATA SELECTORS/MULTIPLEXERS

MARCH 1974—REVISED DECEMBER 1983

- Buffered Inputs and Outputs
- Three Speed/Power Ranges Available

TYPES	TYPICAL AVERAGE PROPAGATION TIME	TYPICAL POWER DISSIPATION
'157	9 ns	150 mW
'L157	18 ns	75 mW
'LS157	9 ns	49 mW
'S157	5 ns	250 mW
'LS158	7 ns	24 mW
'S158	4 ns	195 mW

applications

- Expand Any Data Input Point
- Multiplex Dual Data Buses
- Generate Four Functions of Two Variables (One Variable Is Common)
- Source Programmable Counters

description

These monolithic data selectors/multiplexers contain inverters and drivers to supply full on-chip data selection to the four output gates. A separate strobe input is provided. A 4-bit word is selected from one of two sources and is routed to the four outputs. The '157, 'L157, 'LS157, and 'S157 present true data whereas the 'LS158 and 'S158 present inverted data to minimize propagation delay time.

FUNCTION TABLE

INPUTS			OUTPUT Y		
STROBE \bar{G}	SELECT \bar{A}/\bar{B}	A	B	'157, 'L157, 'LS157, 'S157	'LS158 'S158
H	X	X	X	L	H
L	L	L	X	L	H
L	L	H	X	H	L
L	H	X	L	L	H
L	H	X	H	H	L

H = high level, L = low level, X = irrelevant

absolute maximum ratings over operating free-air temperature range (unless otherwise noted)

Supply voltage, V_{CC} (see Note 1)	7 V
Input voltage: '157, 'L157, 'S158	5.5 V
'LS157, 'LS158	7 V
Operating free-air temperature range: SN54'	-55°C to 125°C
SN74'	0°C to 70°C
Storage temperature range	-65°C to 150°C

NOTE 1: Voltage values are with respect to network ground terminal.

SN54157, SN54LS157, SN54S157,
SN54LS158, SN54S158 . . . J OR W PACKAGE
SN54L157 . . . J PACKAGE
SN74157 . . . J OR N PACKAGE
SN74LS157, SN74S157,
SN74LS158, SN74S158 . . . D, J OR N PACKAGE

(TOP VIEW)

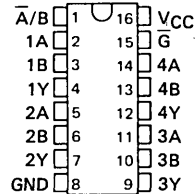

SN54LS157, SN54S157, SN54LS158,
SN54S158 . . . FK PACKAGE
SN74LS157, SN74S157, SN74LS158,
SN74S158 . . . FN PACKAGE

(TOP VIEW)

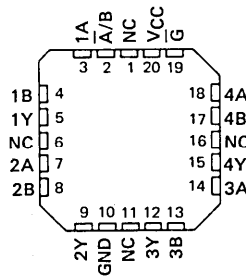

NC - No internal connection

PRODUCTION DATA
This document contains information current as of publication date. Products conform to specifications per the terms of Texas Instruments standard warranty. Production processing does not necessarily include testing of all parameters.

**TEXAS
INSTRUMENTS**

POST OFFICE BOX 225012 • DALLAS, TEXAS 75265

3-589



TTL DEVICES

TYPES SN54157, SN54L157, SN74157 QUADRUPLE 2-LINE TO 1-LINE DATA SELECTORS/MULTIPLEXERS

logic diagram

'157, 'L157

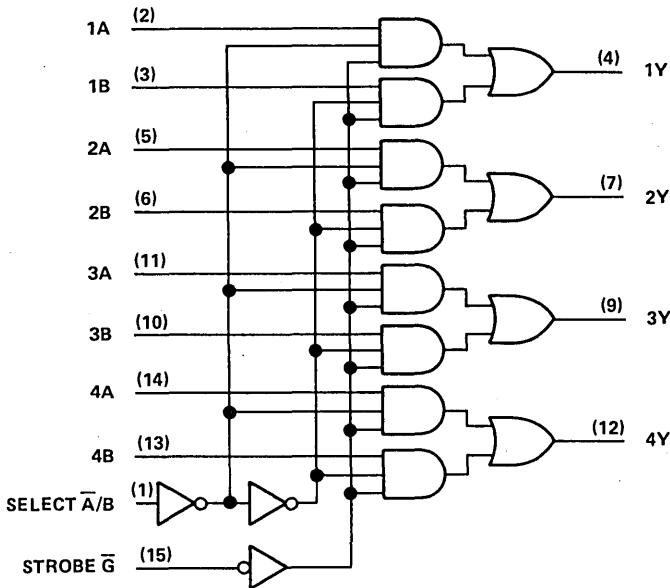

Pin numbers shown on logic notation are for D, J or N packages.

schematics of inputs and outputs

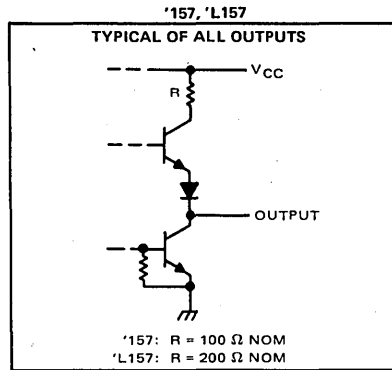
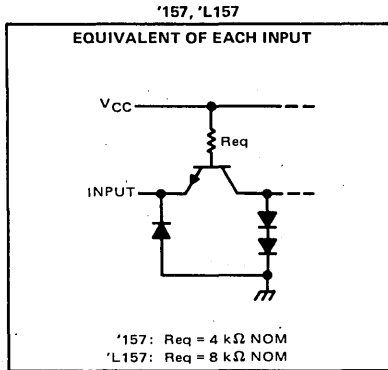

3 TTL DEVICES

TYPES SN54LS157, SN54LS158, SN54S157, SN54S158, SN74LS157, SN74LS158, SN74S157, SN74S158 QUADRUPLE 2-LINE TO 1-LINE DATA SELECTORS/MULTIPLEXERS

logic diagrams

'LS157, 'S157

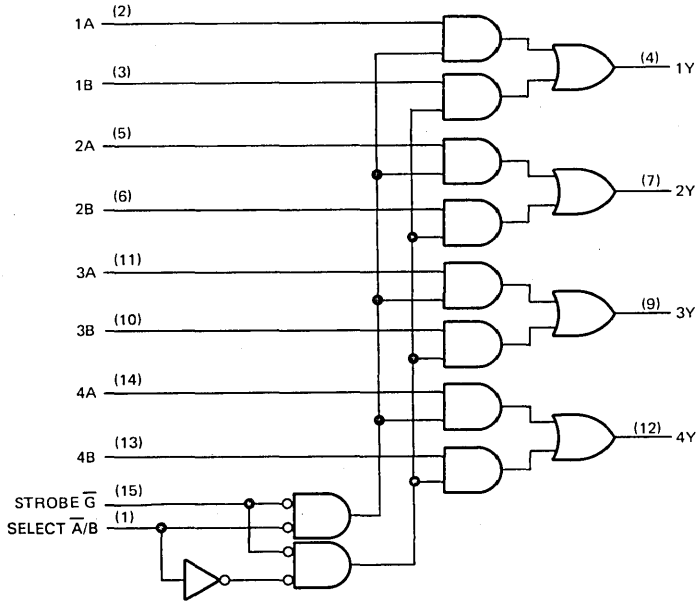

'LS158, 'S158

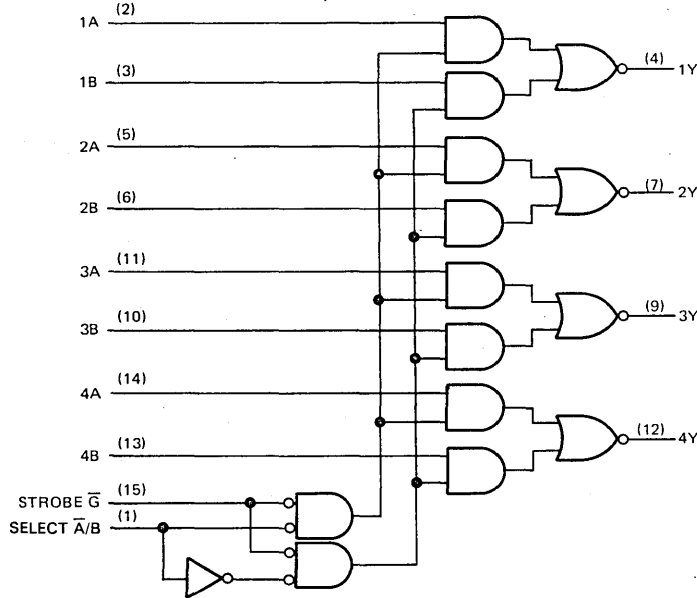

Pin numbers shown on logic notation are for D, J or N packages.

schematics of inputs and outputs

'LS157, 'LS158

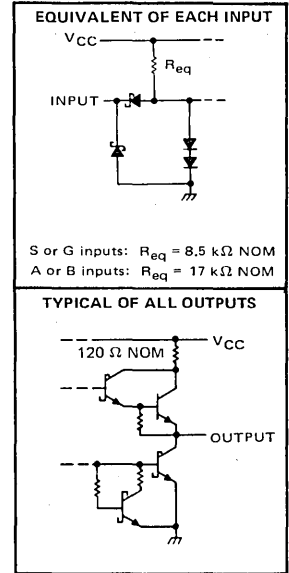

'S157, 'S158

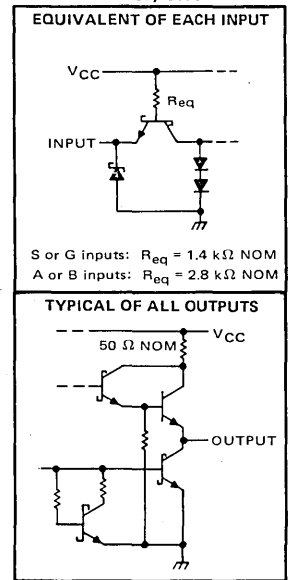

3

TTL DEVICES

TYPES SN54157, SN74157 QUADRUPLE 2-LINE TO 1-LINE DATA SELECTORS/MULTIPLEXERS

recommended operating conditions

	SN54157			SN74157			UNIT
	MIN	NOM	MAX	MIN	NOM	MAX	
Supply voltage, V_{CC}	4.5	5	5.5	4.75	5	5.25	V
High-level output current, I_{OH}			-800			-800	μ A
Low-level output current, I_{OL}			16			16	mA
Operating free-air temperature, T_A	-55		125	0		70	$^{\circ}$ C

electrical characteristics over recommended operating free-air temperature range (unless otherwise noted)

PARAMETER	TEST CONDITIONS†	SN54157			SN74157			UNIT
		MIN	TYP‡	MAX	MIN	TYP‡	MAX	
V_{IH} High-level input voltage		2			2			V
V_{IL} Low-level input voltage				0.8			0.8	V
V_{IK} Input clamp voltage	$V_{CC} = \text{MIN}, I_I = -12 \text{ mA}$			-1.5			-1.5	V
V_{OH} High-level output voltage	$V_{CC} = \text{MIN}, V_{IH} = 2 \text{ V}, V_{IL} = 0.8 \text{ V}, I_{OH} = -800 \mu\text{A}$	2.4	3.4		2.4	3.4		V
V_{OL} Low-level output voltage	$V_{CC} = \text{MIN}, V_{IH} = 2 \text{ V}, V_{IL} = 0.8 \text{ V}, I_{OL} = 16 \text{ mA}$		0.2	0.4		0.2	0.4	V
I_I Input current at maximum input voltage	$V_{CC} = \text{MAX}, V_I = 5.5 \text{ V}$			1			1	mA
I_{IH} High-level input current	$V_{CC} = \text{MAX}, V_I = 2.4 \text{ V}$			40			40	μ A
I_{IL} Low-level input current	$V_{CC} = \text{MAX}, V_I = 0.4 \text{ V}$			-1.6			-1.6	mA
I_{OS} Short-circuit output current§	$V_{CC} = \text{MAX}$	-20		-55	-18		-55	mA
I_{CC} Supply current	$V_{CC} = \text{MAX},$ See Note 2		30	48		30	48	mA

† For conditions shown as MIN or MAX, use the appropriate value specified under recommended operating conditions.

‡ All typical values are at $V_{CC} = 5 \text{ V}, T_A = 25^{\circ}\text{C}$.

§ Not more than one output should be shorted at a time and duration of short-circuit should not exceed one second.

NOTE 2: I_{CC} is measured with 4.5 V applied to all inputs and all outputs open.

switching characteristics, $V_{CC} = 5 \text{ V}, T_A = 25^{\circ}\text{C}$

PARAMETER¶	FROM (INPUT)	TEST CONDITIONS	MIN	TYP	MAX	UNIT
t_{PLH}	Data	$C_L = 15 \text{ pF},$ $R_L = 400 \Omega,$ See Note 3		9	14	ns
t_{PHL}				9	14	
t_{PLH}	Strobe \bar{C}			13	20	ns
t_{PHL}				14	21	
t_{PLH}	Select \bar{A}/\bar{B}			15	23	ns
t_{PHL}				18	27	

¶ t_{PLH} = propagation delay time, low-to-high-level output

t_{PHL} = propagation delay time, high-to-low-level output

NOTE 3: See General Information Section for load circuits and voltage waveforms.

3

TTL DEVICES

TYPE SN54L157

QUADRUPLE 2-LINE TO 1-LINE DATA SELECTORS/MULTIPLEXERS

recommended operating conditions

	MIN	NOM	MAX	UNIT
V _{CC} Supply voltage	4.5	5	5.5	V
I _{OH} High-level output current			-400	μA
I _{OL} Low-level output current			8	mA
T _A Operating free-air temperature	-55		125	°C

electrical characteristics over recommended operating free-air temperature range (unless otherwise noted)

PARAMETER	TEST CONDITIONS†	MIN	TYP‡	MAX	UNIT
V _{IH} High-level input voltage		2			V
V _{IL} Low-level input voltage				0.8	V
V _{IK} Input clamp voltage	V _{CC} = MIN, I _I = -12 mA			-1.5	V
V _{OH} High-level output voltage	V _{CC} = MIN, V _{IH} = 2 V, V _{IL} = 0.8 V, I _{OH} = -400 μA	2.4	3.4		V
V _{OL} Low-level output voltage	V _{CC} = MIN, V _{IH} = 2 V, V _{IL} = 0.8 V, I _{OL} = 8 mA		0.2	0.4	V
I _I Input current at maximum input voltage	V _{CC} = MAX, V _I = 5.5 V			1	mA
I _{IH} High-level input current	V _{CC} = MAX, V _I = 2.4 V			20	μA
I _{IL} Low-level input current	V _{CC} = MAX, V _I = 0.4 V			-0.8	mA
I _{OS} Short-circuit output current§	V _{CC} = MAX	-9		-28	mA
I _{CC} Supply current	V _{CC} = MAX, See Note 2		15	24	mA

† For conditions shown as MIN or MAX, use the appropriate value specified under recommended operating conditions.

‡ All typical values are at V_{CC} = 5 V, T_A = 25°C.

§ Not more than one output should be shorted at a time.

NOTE 2: I_{CC} is measured with 4.5 V applied to all inputs and all outputs open.

switching characteristics, V_{CC} = 5 V, T_A = 25°C

PARAMETER¶	FROM (INPUT)	TEST CONDITIONS	MIN	TYP	MAX	UNIT
t _{PLH}	Data	C _L = 15 pF, R _L = 800 Ω, See Note 3		18	28	ns
t _{PHL}				18	28	
t _{PLH}	Strobe \bar{G}			26	40	ns
t _{PHL}				28	42	
t _{PLH}	Select \bar{A}/B			30	46	ns
t _{PHL}				36	54	

¶ t_{PLH} = propagation delay time, low-to-high-level output

t_{PHL} = propagation delay time, high-to-low-level output

NOTE 3: See General Information Section for load circuits and voltage waveforms.

3

TTL DEVICES

TYPES SN54LS157, SN54LS158, SN74LS157, SN74LS158 QUADRUPLE 2-LINE TO 1-LINE DATA SELECTORS/MULTIPLEXERS

recommended operating conditions

	SN54LS'			SN74LS'			UNIT
	MIN	NOM	MAX	MIN	NOM	MAX	
V _{CC} Supply voltage	4.5	5	5.5	4.75	5	5.25	V
I _{OH} High-level output current	-400			-400			μA
I _{OL} Low-level output current	4			8			mA
T _A Operating free-air temperature	-55		125	0		70	°C

electrical characteristics over recommended operating free-air temperature range (unless otherwise noted)

PARAMETER	TEST CONDITIONS†	SN54LS'			SN74LS'			UNIT
		MIN	TYP‡	MAX	MIN	TYP‡	MAX	
V _{IH} High-level input voltage		2			2			V
V _{IL} Low-level input voltage		0.7			0.8			V
V _{IK} Input clamp voltage	V _{CC} = MIN, I _I = -18 mA	-1.5			-1.5			V
V _{OH} High-level output voltage	V _{CC} = MIN, V _{IH} = 2 V, V _{IL} = MAX, I _{OH} = -400 μA	2.5 3.4		2.7 3.4		V		
V _{OL} Low-level output voltage	V _{CC} = MIN, V _{IH} = 2 V, I _{OL} = 4 mA, I _{OL} = 8 mA	0.25 0.4		0.25 0.4		V		
I _I Input current at maximum input voltage	A/B or \bar{G}	0.2			0.2			mA
	A or B	0.1			0.1			
I _{IH} High-level input current	A/B or \bar{G}	40			40			μA
	A or B	20			20			
I _{IL} Low-level input current	A/B or \bar{G}	-0.8			-0.8			mA
	A or B	-0.4			-0.4			
I _{OS} Short-circuit output current §	V _{CC} = MAX	-20	-100	-20	-100	mA		
I _{CC} Supply current	V _{CC} = MAX, See Note 2	'LS157	9.7	16	9.7	16	mA	
		'LS158	4.8	8	4.8	8		
	V _{CC} = MAX, All A inputs at 4.5 V, All other inputs at 0 V	'LS158	6.5	11	6.5	11		

† For conditions shown as MIN or MAX, use the appropriate value specified under recommended operating conditions.

‡ All typical values are at V_{CC} = 5 V, T_A = 25° C.

§ Not more than one output should be shorted at a time and duration of short-circuit should not exceed one second.

NOTE 2: I_{CC} is measured with 4.5 V applied to all inputs and all outputs open.

switching characteristics, V_{CC} = 5 V, T_A = 25° C

PARAMETER ¶	FROM (INPUT)	TEST CONDITIONS	'LS157			'LS158			UNIT
			MIN	TYP	MAX	MIN	TYP	MAX	
t _{PLH}	Data	C _L = 15 pF, R _L = 2 kΩ, See Note 3	9		14	7		12	ns
t _{PHL}			9		14	10		15	
t _{PLH}	Strobe \bar{G}		13		20	11		17	ns
t _{PHL}			14		21	18		24	
t _{PLH}	Select \bar{A}/\bar{B}		15		23	13		20	ns
t _{PHL}			18		27	16		24	

¶ t_{PLH} ≡ propagation delay time, low-to-high-level output

t_{PHL} ≡ propagation delay time, high-to-low-level output

NOTE 3. See General Information Section for load circuits and voltage waveforms.

TYPES SN54S157, SN54S158, SN74S157, SN74S158 QUADRUPLE 2-LINE TO 1-LINE DATA SELECTORS/MULTIPLEXERS

recommended operating conditions

	SN54S157 SN54S158			SN74S157 SN74S158			UNIT
	MIN	NOM	MAX	MIN	NOM	MAX	
Supply voltage, V_{CC}	4.5	5	5.5	4.75	5	5.25	V
High-level output current, I_{OH}			-1			-1	mA
Low-level output current, I_{OL}			20			20	mA
Operating free-air temperature, T_A	-55		125	0		70	$^{\circ}$ C

electrical characteristics over recommended operating free-air temperature range (unless otherwise noted)

PARAMETER	TEST CONDITIONS†	SN54S157 SN74S157		SN54S158 SN74S158		UNIT
		MIN	TYP‡	MAX	MIN	
V_{IH} High-level input voltage		2		2		V
V_{IL} Low-level input voltage		0.8		0.8		V
V_{IK} Input clamp voltage	$V_{CC} = \text{MIN}, I_I = -18 \text{ mA}$	-1.2		-1.2		V
V_{OH} High-level output voltage	$V_{CC} = \text{MIN}, V_{IH} = 2 \text{ V},$ $V_{IL} = 0.8 \text{ V}, I_{OH} = -1 \text{ mA}$	Series 54S 2.5	3.4	Series 74S 2.5	3.4	V
V_{OL} Low-level output voltage	$V_{CC} = \text{MIN}, V_{IH} = 2 \text{ V},$ $V_{IL} = 0.8 \text{ V}, I_{OL} = 20 \text{ mA}$	0.5		0.5		V
I_I Input current at maximum input voltage	$V_{CC} = \text{MAX}, V_I = 5.5 \text{ V}$	1		1		mA
I_{IH} High-level input current	$\overline{A/B}$ or \overline{G}	100		100		μ A
	A or B	50		50		
I_{IL} Low-level input current	$\overline{A/B}$ or \overline{G}	-4		-4		mA
	A or B	-2		-2		
I_{OS} Short-circuit output current§	$V_{CC} = \text{MAX}$	-40	-100	-40	-100	mA
I_{CC} Supply current	$V_{CC} = \text{MAX},$ All inputs at 4.5 V, See Note 2	50	78	39	61	mA
	$V_{CC} = \text{MAX},$ A inputs at 4.5 V, B,G,S, inputs at 0 V, See Note 2				81	

† For conditions shown as MIN or MAX, use the appropriate value specified under recommended operating conditions.

‡ All typical values are at $V_{CC} = 5 \text{ V}, T_A = 25^{\circ}\text{C}$.

§ Not more than one output should be shorted at a time, and duration of the short-circuit should not exceed one second.

Note 2: I_{CC} is measured with all outputs open.

switching characteristics, $V_{CC} = 5 \text{ V}, T_A = 25^{\circ}\text{C}$

PARAMETER¶	FROM (INPUT)	TEST CONDITIONS	SN54S157 SN74S157		SN54S158 SN74S158		UNIT
			MIN	TYP	MAX	MIN	
t_{PLH}	Data	$C_L = 15 \text{ pF},$ $R_L = 280 \Omega,$ See Note 3	5	7.5	4	6	ns
t_{PHL}			4.5	6.5	4	6	
t_{PLH}	Strobe \overline{G}		8.5	12.5	6.5	11.5	ns
t_{PHL}			7.5	12	7	12	
t_{PLH}	Select $\overline{A/B}$		9.5	15	8	12	ns
t_{PHL}			9.5	15	8	12	

¶ t_{PLH} = propagation delay time, low-to-high-level output

t_{PHL} = propagation delay time, high-to-low-level output

NOTE 3: See General Information Section for load circuits and voltage waveforms.

TTL DEVICES

TYPES SN54159, SN74159 4-LINE TO 16-LINE DECODERS/DEMULTIPLEXERS WITH OPEN-COLLECTOR OUTPUTS

DECEMBER 1972—REVISED DECEMBER 1983

- Open-Collector Outputs for Interfacing with MOS or Memory Decoders/Drivers
- Decodes 4 Binary-Coded Inputs into One of 16 Mutually Exclusive Outputs
- Performs the Demultiplexing Function by Distributing Data from One Input Line to Any One of 16 Outputs
- Typical Average Propagation Delay Times:
24 ns through 3 levels of Logic
19 ns from Strobe Input
- Output Off-State Current is Less Than 50 μ A
- Fully Compatible with Most TTL, and MSI Circuits

SN54159 . . . J OR W PACKAGE

SN74159 . . . J OR N PACKAGE

(TOP VIEW)

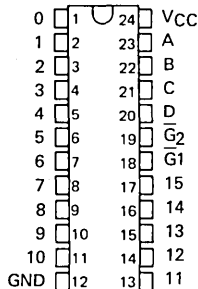

description

Each of these monolithic, 4-line-to-16 line decoders utilizes TTL circuitry to decode four binary-coded inputs into one of sixteen mutually exclusive open-collector outputs when both the strobe inputs, \bar{G}_1 and \bar{G}_2 , are low. The demultiplexing function is performed by using the 4 input lines to address the output line, passing data from one of the strobe inputs with the other strobe input low. When either strobe input is high, all outputs are high. These demultiplexers are ideally suited for implementing MOS memory decoding or for interfacing with discrete memory address drivers. For ultra-high-speed applications, the SN54S138/SN74S138 or SN54S139/SN74S139 is recommended.

These circuits are fully compatible for use with most other TTL circuits. Input clamping diodes are provided to minimize transmission-line effects and thereby simplify system design. Input buffers are used to lower the fan-in requirement to only one normalized Series 54/74 load. A fan-out to 10 normalized Series 54/74 loads in the low-level state is available from each of the sixteen outputs. Typical power dissipation is 170 mW.

The SN54159 is characterized for operation over the full military temperature range of -55°C to 125°C ; the SN74159 is characterized for operation from 0°C to 70°C .

function table

Same as SN54154, SN74154.

logic diagram

Same as SN54154, SN74154.

absolute maximum ratings over operating free-air temperature range (unless otherwise noted)

Supply voltage, V_{CC} (see Note 1)	7 V
Input voltage	5.5 V
Off-state output voltage	5.5 V
Operating free-air temperature range: SN54159 Circuits	-55°C to 125°C
SN74159 Circuits	0°C to 70°C
Storage temperature range	-65°C to 150°C

NOTE 1: Voltage values are with respect to network ground terminal.

PRODUCTION DATA

This document contains information current as of publication date. Products conform to specifications per the terms of Texas Instruments standard warranty. Production processing does not necessarily include testing of all parameters.

TYPES SN54159, SN74159

4-LINE TO 16-LINE DECODERS/DEMULTIPLEXERS WITH OPEN-COLLECTOR OUTPUTS

recommended operating conditions

	SN54159			SN74159			UNIT		
	MIN	NOM	MAX	MIN	NOM	MAX			
Supply voltage, V_{CC}	4.5	5	5.5	4.75	5	5.25	V		
Low-level output current, I_{OL}	16			16			mA		
Operating free-air temperature, T_A	-55			125			0	70	°C

electrical characteristics over recommended operating free-air temperature range (unless otherwise noted)

PARAMETER	TEST CONDITIONS†	MIN	TYP‡	MAX	UNIT
V_{IH} High-level input voltage		2			V
V_{IL} Low-level input voltage		0.8			V
V_{IK} Input clamp voltage	$V_{CC} = \text{MIN}, I_I = -12 \text{ mA}$	-1.5			V
I_{OH} High-level output current	$V_{CC} = \text{MIN}, V_{IH} = 2 \text{ V}, V_{IL} = 0.8 \text{ V}, V_{OH} = 5.5 \text{ V}$	50			μA
V_{OL} Low-level output voltage	$V_{CC} = \text{MIN}, V_{IH} = 2 \text{ V}, V_{IL} = 0.8 \text{ V}, I_{OL} = 16 \text{ mA}$	0.4			V
I_I Input current at maximum input voltage	$V_{CC} = \text{MAX}, V_I = 5.5 \text{ V}$	1			mA
I_{IH} High-level input current	$V_{CC} = \text{MAX}, V_I = 2.4 \text{ V}$	40			μA
I_{IL} Low-level input current	$V_{CC} = \text{MAX}, V_I = 0.4 \text{ V}$	-1.6			mA
I_{CC} Supply current	$V_{CC} = \text{MAX}, \text{ All inputs grounded}$	34		56	mA

†For conditions shown as MIN or MAX, use the appropriate value specified under recommended operating conditions for the applicable type.

‡All typical values are at $V_{CC} = 5 \text{ V}, T_A = 25^\circ\text{C}$.

switching characteristics, $V_{CC} = 5 \text{ V}, T_A = 25^\circ\text{C}$

PARAMETER	TEST CONDITIONS	MIN	TYP	MAX	UNIT
t_{PLH} Propagation delay time, low-to-high-level output, from A, B, C, or D inputs through 3 levels of logic	$C_L = 15 \text{ pF}, R_L = 400 \Omega, \text{ See Note 2}$	23		36	ns
t_{PHL} Propagation delay time, high-to-low-level output, from A, B, C, or D inputs through 3 levels of logic		24		36	ns
t_{PLH} Propagation delay time, low-to-high-level output, from either strobe input		15		25	ns
t_{PHL} Propagation delay time, high-to-low-level output, from either strobe input		22		36	ns

NOTE 2: See General Information Section for load circuits and voltage waveforms.

schematics of inputs and outputs

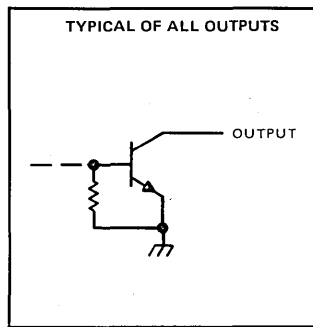
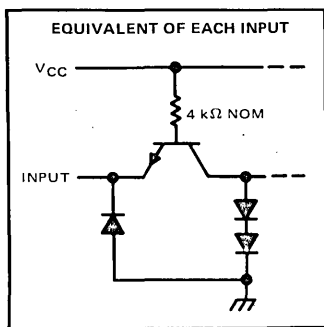

3
TTL DEVICES

TYPES SN54160 THRU SN54163, SN54LS160A THRU SN54LS163A, SN54S162, SN54S163, SN74160 THRU SN74163, SN74LS160A THRU SN74LS163A, SN74S162, SN74S163 SYNCHRONOUS 4-BIT COUNTERS

OCTOBER 1976—REVISED DECEMBER 1983

'160, '161, 'LS160A, 'LS161A . . . SYNCHRONOUS COUNTERS WITH DIRECT CLEAR
'162, '163, 'LS162A, 'LS163A, 'S162, 'S163 . . . FULLY SYNCHRONOUS COUNTERS

- Internal Look-Ahead for Fast Counting
- Carry Output for n-Bit Cascading
- Synchronous Counting
- Synchronously Programmable
- Load Control Line
- Diode-Clamped Inputs

SERIES 54', 54LS', 54S' . . . J OR W PACKAGE
SERIES 74' . . . J OR N PACKAGE
SERIES 74LS', 74S' . . . D, J OR N PACKAGE

(TOP VIEW)

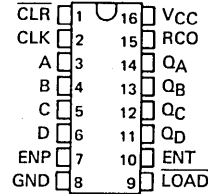

NC—No internal connection

SERIES 54LS', 54S' . . . FK PACKAGE
SERIES 74LS', 74S' . . . FN PACKAGE

(TOP VIEW)

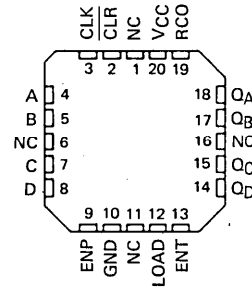

NC—No internal connection

TYPE	TYPICAL PROPAGATION TIME, CLOCK TO Q OUTPUT	TYPICAL MAXIMUM CLOCK FREQUENCY	TYPICAL POWER DISSIPATION
'160 thru '163	14 ns	32 MHz	305 mW
'LS162A thru 'LS163A	14 ns	32 MHz	93 mW
'S162 and 'S163	9 ns	70 MHz	475 mW

description

These synchronous, presettable counters feature an internal carry look-ahead for application in high-speed counting designs. The '160, '162, 'LS160A, 'LS162A, and 'S162 are decade counters and the '161, '163, 'LS161A, 'LS163A, and 'S163 are 4-bit binary counters. Synchronous operation is provided by having all flip-flops clocked simultaneously so that the outputs change coincident with each other when so instructed by the count-enable inputs and internal gating. This mode of operation eliminates the output counting spikes that are normally associated with asynchronous (ripple clock) counters, however counting spikes may occur on the (RCO) ripple carry output. A buffered clock input triggers the four flip-flops on the rising edge of the clock input waveform.

These counters are fully programmable; that is, the outputs may be preset to either level. As presetting is synchronous, setting up a low level at the load input disables the counter and causes the outputs to agree with the setup data after the next clock pulse regardless of the levels of the enable inputs. Low-to-high transitions at the load input of the '160 thru '163 should be avoided when the clock is low if the enable inputs are high at or before the transition. This restriction is not applicable to the 'LS160A thru 'LS163A or 'S162 or 'S163. The clear function for the '160, '161, 'LS160A, and 'LS161A is asynchronous and a low level at the clear input sets all four of the flip-flop outputs low regardless of the levels of clock, load, or enable inputs. The clear function for the '162, '163, 'LS162A, 'LS163A, 'S162, and 'S163 is synchronous and a low level at the clear input sets all four of the flip-flop outputs low after the next clock pulse, regardless of the levels of the enable inputs. This synchronous clear allows the count length to be modified easily as decoding the maximum count desired can be accomplished with one external NAND gate. The gate output is connected to the clear input to synchronously clear the counter to 0000 (LLLL). Low-to-high transitions at the clear input of the '162 and '163 should be avoided when the clock is low if the enable and load inputs are high at or before the transition.

PRODUCTION DATA

This document contains information current as of publication date. Products conform to specifications per the terms of Texas Instruments standard warranty. Production processing does not necessarily include testing of all parameters.

TEXAS
INSTRUMENTS

POST OFFICE BOX 225012 • DALLAS, TEXAS 75265

TYPES SN54160 THRU SN54163, SN54LS160A THRU SN54LS163A, SN54S162, SN54S163, SN74160 THRU SN74163, SN74LS160A THRU SN74LS163A, SN74S162, SN74S163 SYNCHRONOUS 4-BIT COUNTERS

The carry look-ahead circuitry provides for cascading counters for n-bit synchronous applications without additional gating. Instrumental in accomplishing this function are two count-enable inputs and a ripple carry output. Both count-enable inputs (P and T) must be high to count, and input T is fed forward to enable the ripple carry output. The ripple carry output thus enabled will produce a high-level output pulse with a duration approximately equal to the high-level portion of the Q_A output. This high-level overflow ripple carry pulse can be used to enable successive cascaded stages. High-to-low-level transitions at the enable P or T inputs of the '160 thru '163 should occur only when the clock input is high. Transitions at the enable P or T inputs of the 'LS160A thru 'LS163A or 'S162 and 'S163 are allowed regardless of the level of the clock input.

'LS160A thru 'LS163A, 'S162 and 'S163 feature a fully independent clock circuit. Changes at control inputs (enable P or T, or load) that will modify the operating mode have no effect until clocking occurs. The function of the counter (whether enabled, disabled, loading, or counting) will be dictated solely by the conditions meeting the stable setup and hold times.

The 'LS160A thru 'LS163A are completely new designs. Compared to the original 'LS160 thru 'LS163, they feature 0-nanosecond minimum hold time and reduced input currents I_{IH} and I_{IL}.

N-BIT SYNCHRONOUS COUNTERS

This application demonstrates how the look-ahead carry circuit can be used to implement a high-speed n-bit counter. The '160, '162, 'LS160A, 'LS162A, or 'S162 will count in BCD and the '161, '163, 'LS161A, 'LS163A or 'S163 will count in binary. Virtually any count mode (modulo-N, N₁-to-N₂, N₁-to-maximum) can be used with this fast look-ahead circuit.

logic symbols

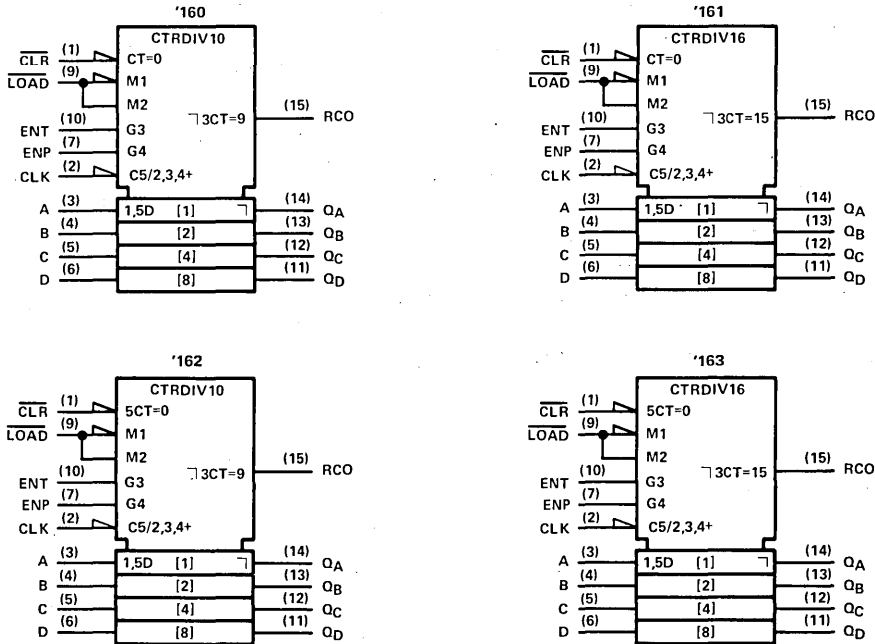

Pin numbers shown on logic notation are for D, J or N packages.

TYPES SN54LS160A THRU SN54LS163A, SN54S162, SN54S163,
SN74LS160A THRU SN74LS163A, SN74S162, SN74S163
SYNCHRONOUS 4-BIT COUNTERS

logic symbols (continued)

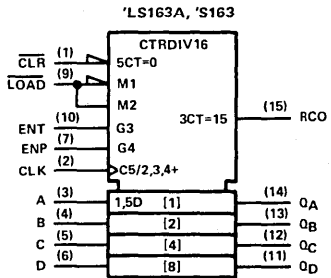
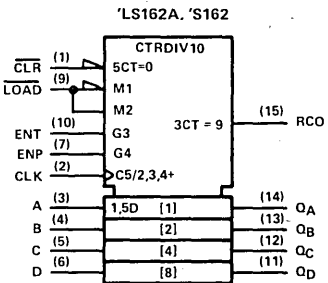
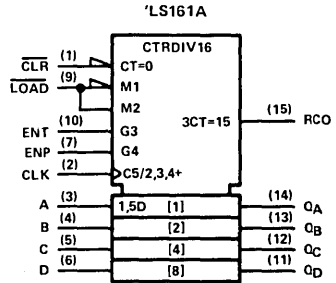
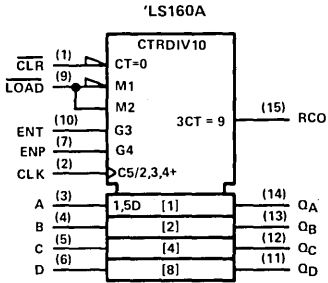

Pin numbers shown on logic notation are for D, J or N packages.

3

TTL DEVICES

SN54160, SN54162, SN74160, SN74162 SYNCHRONOUS 4-BIT COUNTERS

logic diagram

SN54160, SN74160 SYNCHRONOUS DECADE COUNTERS

SN54162, SN74162 synchronous decade counters are similar; however the clear is synchronous as shown for the SN54163, SN74163 binary counters at right.

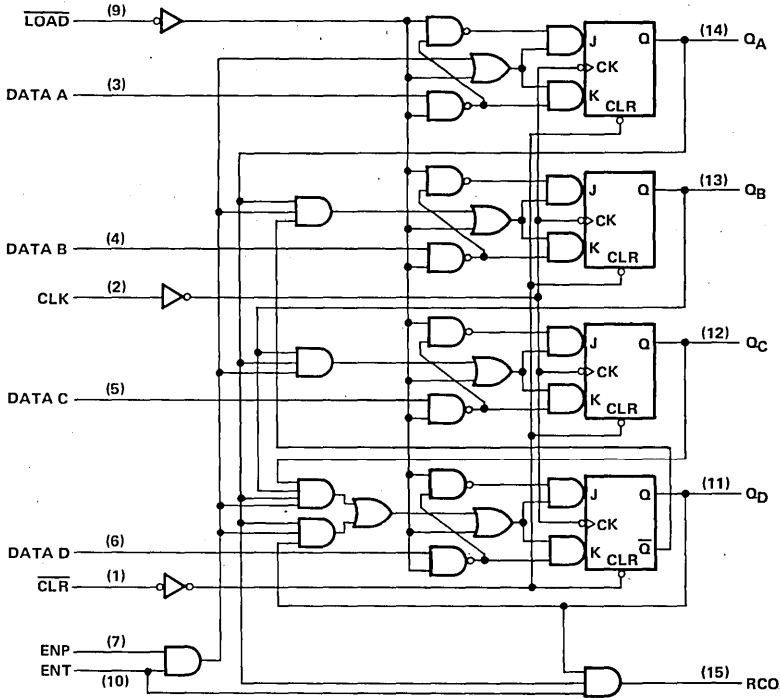

Pin numbers shown on logic notation are for D, J or N packages.

SN54161, SN54163, SN74161, SN74163 SYNCHRONOUS 4-BIT COUNTERS

logic diagram

SN54163, SN74163 SYNCHRONOUS BINARY COUNTERS

SN54161, SN74161 synchronous binary counters are similar; however, the clear is asynchronous as shown for the SN54160, SN74160 decade counters at left.

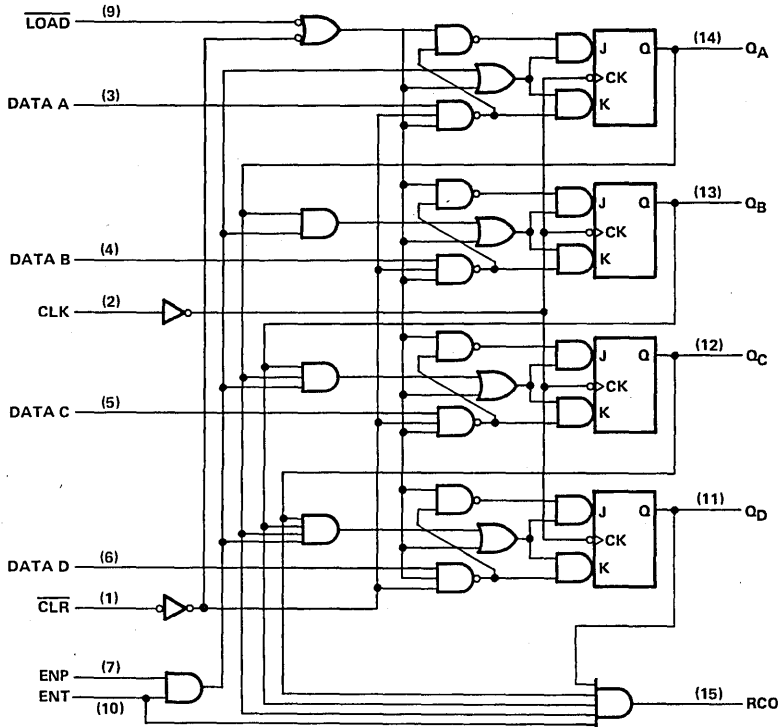

Pin numbers shown on logic notation are for D, J or N packages.

3

TTL DEVICES

SN54LS160A, SN54LS162A, SN74LS160A, SN74LS162A SYNCHRONOUS 4-BIT COUNTERS

logic diagram

SN54LS160A, SN74LS160A SYNCHRONOUS DECADE COUNTERS

SN54LS162A, SN74LS162A synchronous decade counters are similar; however the clear is synchronous as shown for the SN54LS163A, SN74LS163A binary counters at right.

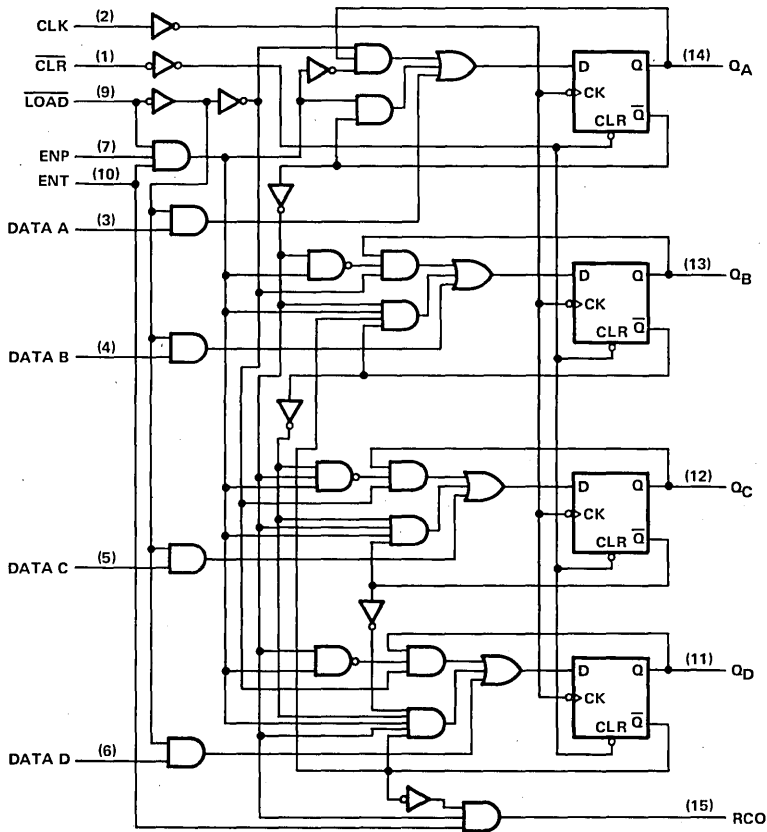

Pin numbers shown on logic notation are for D, J or N packages.

3

TTL DEVICES

SN54LS161A, SN54LS163A, SN74LS161A, SN74LS163A SYNCHRONOUS 4-BIT COUNTERS

logic diagram

SN54LS163A, SN74LS163A SYNCHRONOUS BINARY COUNTERS

SN54LS161A, SN74LS161A synchronous binary counters are similar; however, the clear is asynchronous as shown for the SN54LS160A, SN74LS160A decade counters at left.

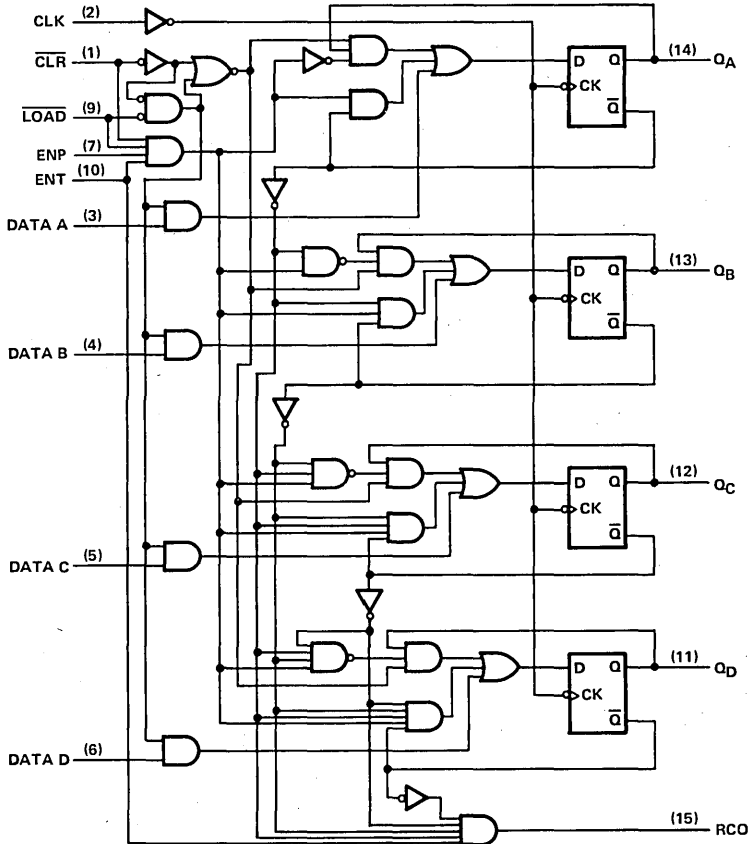

Pin numbers shown on logic notation are for D, J or N packages.

3

TTL DEVICES

SN54S162, SN74S162
 SYNCHRONOUS 4-BIT COUNTERS

logic diagram

SN54S162, SN74S162 SYNCHRONOUS DECADE COUNTER

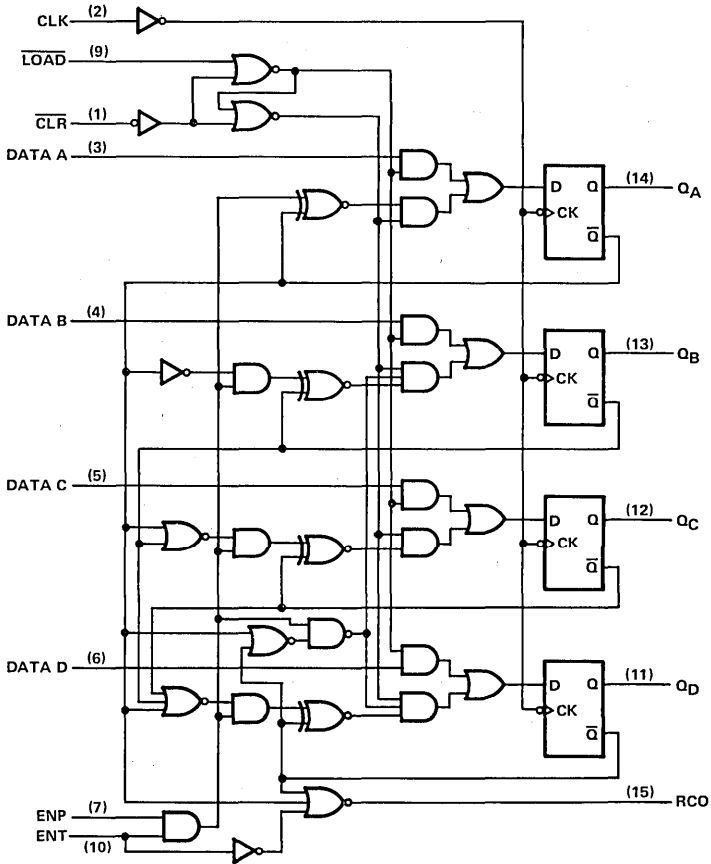

Pin numbers shown on logic notation are for D, J or N packages.

SN54S163, SN74S163
 SYNCHRONOUS 4-BIT COUNTERS

logic diagram

SN54S163, SN74S163 SYNCHRONOUS DECADE COUNTER

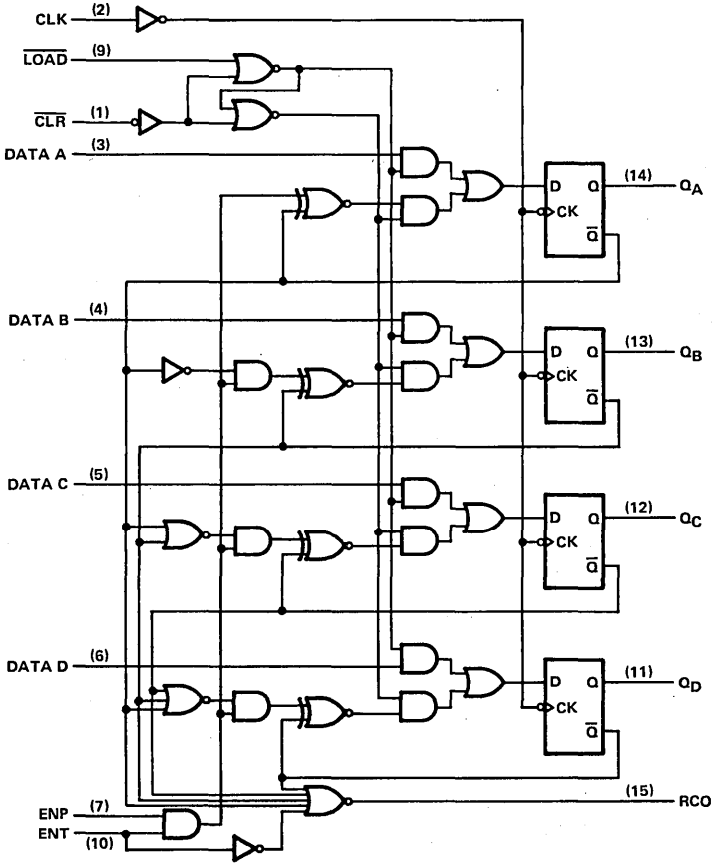

Pin numbers shown on logic notation are for D, J or N packages.

3
 TTL DEVICES



**TYPES SN54160, SN54162, SN54LS160A, SN54LS162A, SN54S162,
SN74160, SN74162, SN74LS160A, SN74LS162A, SN74S162
SYNCHRONOUS 4-BIT COUNTERS**

'160, '162, 'LS160A, 'LS162A, 'S162 DECADE COUNTERS

typical clear, preset, count, and inhibit sequences

Illustrated below is the following sequence:

1. Clear outputs to zero ('160 and 'LS160A are asynchronous; '162, 'LS162A, and 'S162 are synchronous)
2. Preset to BCD seven
3. Count to eight, nine, zero, one, two, and three
4. Inhibit

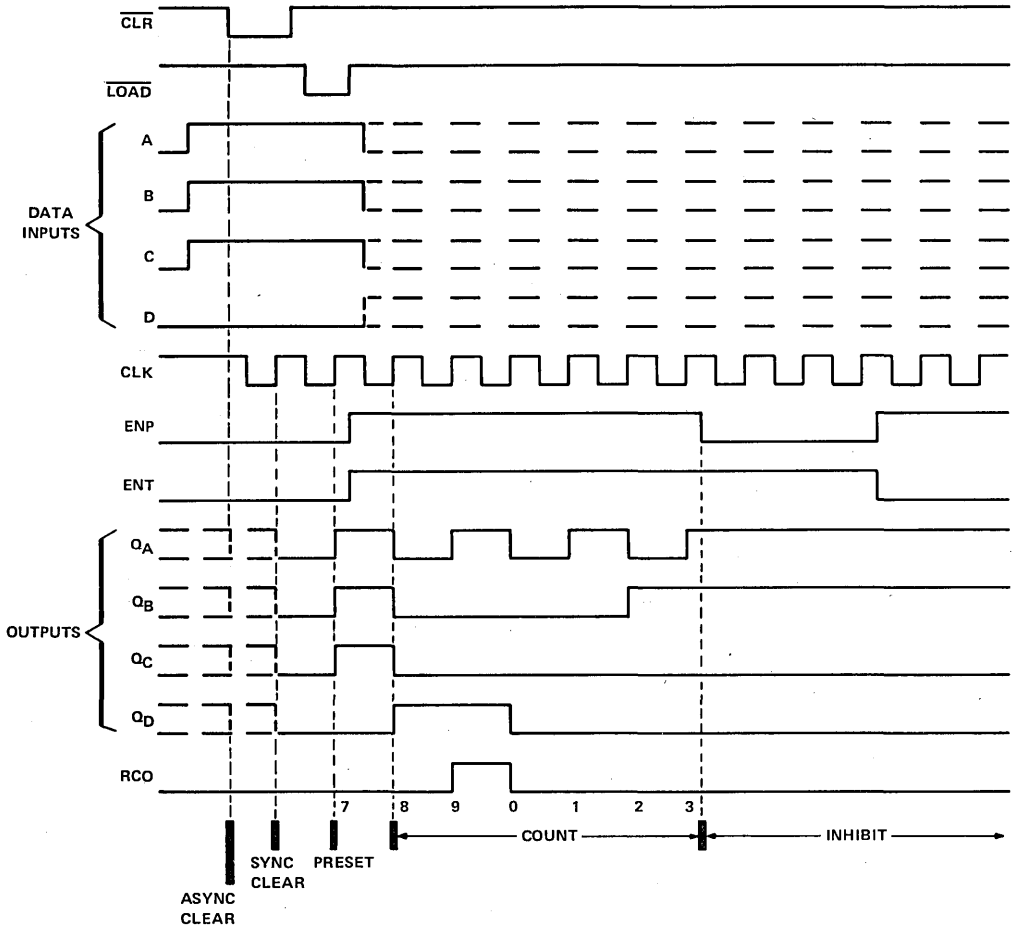

TTL DEVICES

TYPES SN54161, SN54163, SN54LS161A, SN54LS163A, SN54S163,
 SN74161, SN74163, SN74LS161A, SN74LS163A, SN74S163
 SYNCHRONOUS 4-BIT COUNTERS

'161, 'LS161A, '163, 'LS163A, 'S163 BINARY COUNTERS

typical clear, preset, count, and inhibit sequences

Illustrated below is the following sequence:

1. Clear outputs to zero ('161 and 'LS161A are asynchronous; '163, 'LS163A, and 'S163 are synchronous)
2. Preset to binary twelve
3. Count to thirteen, fourteen fifteen, zero, one, and two
4. Inhibit

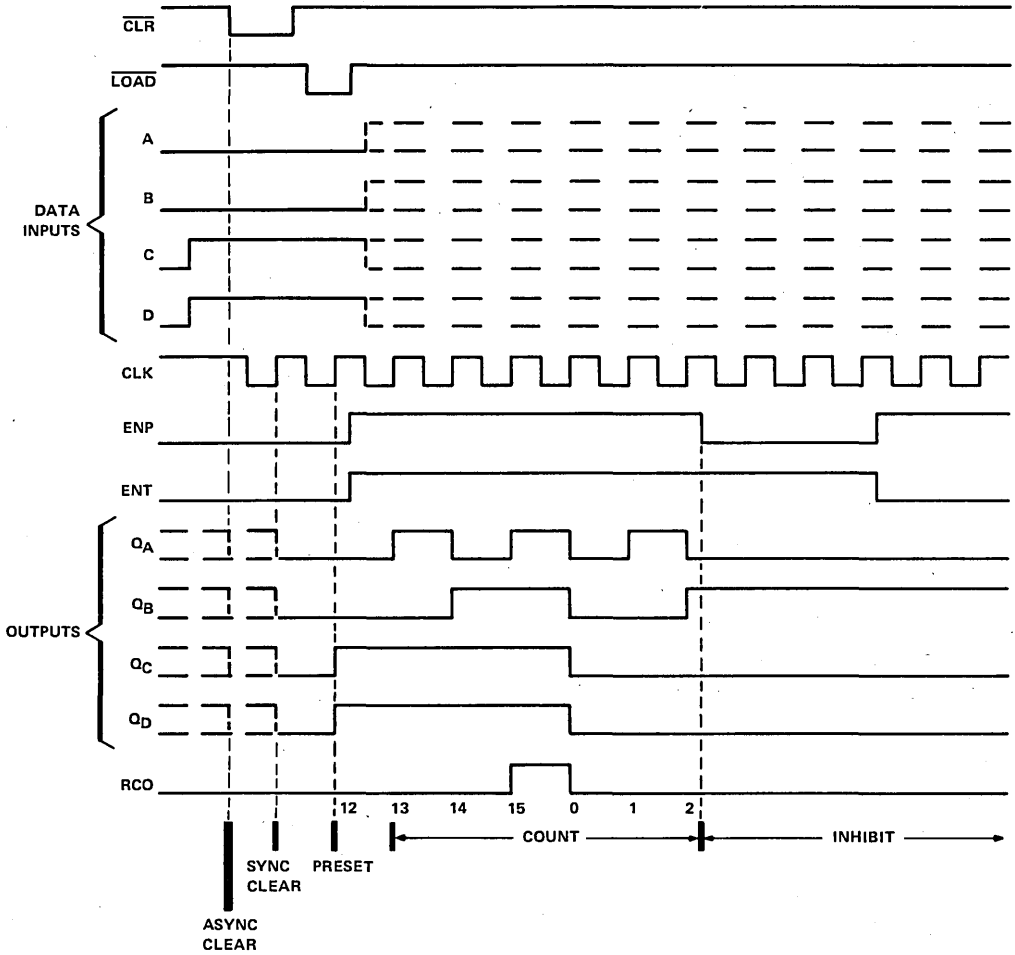

SN54160 THRU SN54163, SN74160 THRU SN74163 SYNCHRONOUS 4-BIT COUNTERS

schematics of inputs and outputs

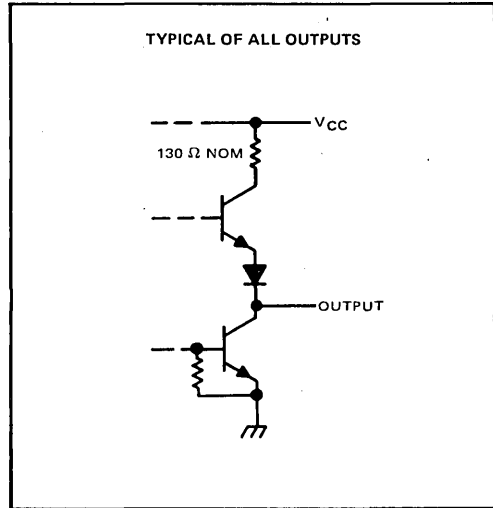
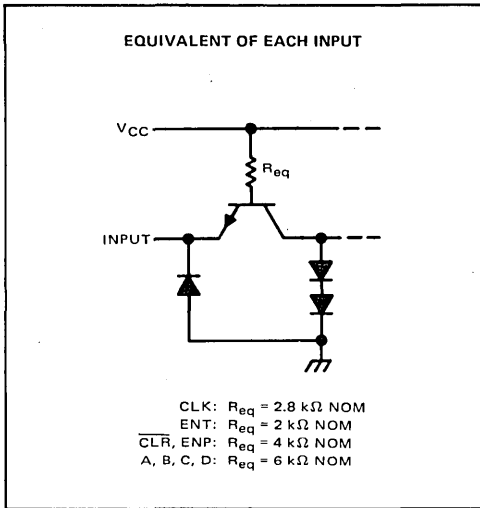

absolute maximum ratings over operating free-air temperature range (unless otherwise noted)

Supply voltage, V_{CC} (see Note 1)	7 V
Input voltage	5.5 V
Interemitter voltage (see Note 2)	5.5 V
Operating free-air temperature range: SN54' Circuits	-55°C to 125°C
SN74' Circuits	0°C to 70°C
Storage temperature range	-65°C to 150°C

- NOTES: 1. Voltage values, except interemitter voltage, are with respect to network ground terminal.
 2. This is the voltage between two emitters of a multiple-emitter transistor. For these circuits, this rating applies between the count enable inputs P and T.

recommended operating conditions

	SN54160, SN54161			SN74160, SN74161			UNIT
	SN54162, SN54163			SN74162, SN74163			
	MIN	NOM	MAX	MIN	NOM	MAX	
Supply voltage, V_{CC}	4.5	5	5.5	4.75	5	5.25	V
High-level output current, I_{OH}			-800			-800	μA
Low-level output current, I_{OL}			16			16	mA
Clock frequency, f_{clock}	0		25	0		25	MHz
Width of clock pulse, $t_w(\text{clock})$	25			25			ns
Width of clear pulse, $t_w(\text{clear})$	20			20			ns
Setup time, t_{su} (see Figures 1 and 2)	Data inputs A, B, C, D	20		20			ns
	ENP	20		20			
	LOAD	25		25			
	CLR [†]	20		20			
Hold time at any input, t_h	0			0			ns
Operating free-air temperature, T_A	-55		125	0		70	°C

[†]This applies only for '162 and '163, which have synchronous clear inputs.

SN54160 THRU SN54163, SN74160 THRU SN74163 SYNCHRONOUS 4-BIT COUNTERS

electrical characteristics over recommended operating free-air temperature range (unless otherwise noted)

PARAMETER	TEST CONDITIONS†	SN54160, SN54161		SN74160, SN74161		UNIT
		SN54162, SN54163		SN74162, SN74163		
		MIN	TYP‡	MAX	MIN	
V _{IH} High-level input voltage		2		2		V
V _{IL} Low-level input voltage		0.8		0.8		V
V _{IK} Input clamp voltage	V _{CC} = MIN, I _I = -12 mA	-1.5		-1.5		V
V _{OH} High-level output voltage	V _{CC} = MIN, V _{IH} = 2 V, V _{IL} = 0.8 V, I _{OH} = -800 μA	2.4	3.4	2.4	3.4	V
V _{OL} Low-level output voltage	V _{CC} = MIN, V _{IH} = 2 V, V _{IL} = 0.8 V, I _{OL} = 16 mA	0.2	0.4	0.2	0.4	V
I _I Input current at maximum input voltage	V _{CC} = MAX, V _I = 5.5 V	1		1		mA
I _{IH} High-level input current	CLK or ENT	80		80		μA
	Other inputs	40		40		
I _{IL} Low-level input current	CLK or ENT	-3.2		-3.2		mA
	Other inputs	-1.6		-1.6		
I _{OS} Short-circuit output current‡	V _{CC} = MAX	-20	-57	-18	-57	mA
I _{CCH} Supply current, all outputs high	V _{CC} = MAX, See Note 3	59	85	59	94	mA
I _{CCL} Supply current, all outputs low	V _{CC} = MAX, See Note 4	63	91	63	101	mA

† For conditions shown as MIN or MAX, use the appropriate value specified under recommended operating conditions.

‡ All typical values are at V_{CC} = 5 V, T_A = 25°C.

§ Not more than one output should be shorted at a time.

NOTES: 3. I_{CCH} is measured with the load input high, then again with the load input low, with all other inputs high and all outputs open.

4. I_{CCL} is measured with the clock input high, then again with the clock input low, with all other inputs low and all outputs open.

switching characteristics, V_{CC} = 5 V, T_A = 25°C

PARAMETER †	FROM (INPUT)	TO (OUTPUT)	TEST CONDITIONS	MIN	TYP	MAX	UNIT
f _{max}			C _L = 15 pF, R _L = 400 Ω, See Figures 1 and 2 and Note 5	25	32		ns
t _{PLH}	CLK	RCO		23	35		ns
t _{PHL}				23	35		
t _{PLH}	CLK	Any		13	20		ns
t _{PHL}	(LOAD input low)	Q		15	23		
t _{PLH}	CLK	Any		17	25		ns
t _{PHL}	(LOAD input high)	Q		19	29		
t _{PLH}	ENT	RCO		11	16		ns
t _{PHL}				11	16		
t _{PHL}	CLR	Any Q		26	38		ns

† f_{max} = Maximum clock frequency

t_{PLH} = propagation delay time, low-to-high-level output

t_{PHL} = propagation delay time, high-to-low-level output

NOTE 5: Propagation delay for clearing is measured from the clear input for the '160 and '161 or from the clock input transition for the '162 and '163.



TTL DEVICES

SN54LS160A THRU SN54LS163A, SN74LS160A THRU SN74LS163A SYNCHRONOUS 4-BIT COUNTERS

schematics of inputs and outputs

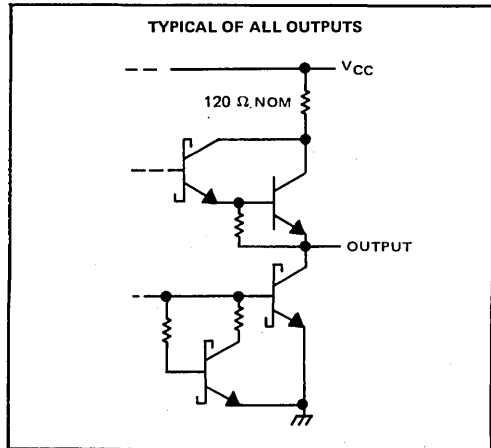
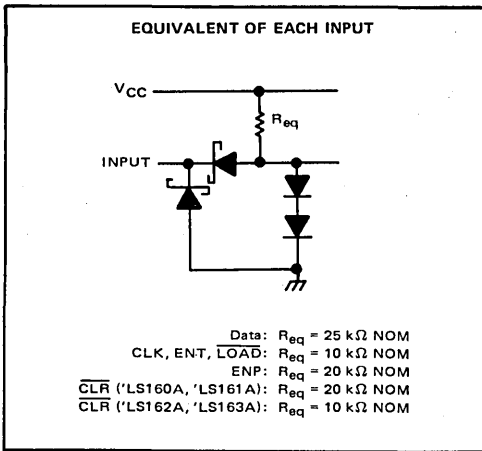

absolute maximum ratings over operating free-air temperature range (unless otherwise noted)

Supply voltage, V_{CC} (see Note 7)	7 V
Input voltage	7 V
Operating free-air temperature range: SN54LS' Circuits	-55°C to 125°C
SN74LS' Circuits	0°C to 70°C
Storage temperature range	-65°C to 150°C

NOTE 7: Voltage values are with respect to network ground terminal.

recommended operating conditions

		SN54LS'			SN74LS'			UNIT
		MIN	NOM	MAX	MIN	NOM	MAX	
V_{CC}	Supply voltage	4.5	5	5.5	4.75	5	5.25	V
I_{OH}	High-level output current			-400			-400	μA
I_{OL}	Low-level output current			4			8	mA
f_{clock}	Clock frequency	0		25	0		25	MHz
$t_{w(\text{clock})}$	Width of clock pulse	25			25			ns
$t_{w(\text{clear})}$	Width of clear pulse	20			20			ns
t_{su}	Setup time, (see Figures 1 and 2)	Data inputs A, B, C, D	20		20			ns
		ENP or ENT	20		20			
		$\overline{\text{LOAD}}$	20		20			
		$\overline{\text{LOAD}}$ inactive state	20		20			
		$\overline{\text{CLR}}^1$	20		20			
		CLR inactive state	25		25			
t_h	Hold time at any input	9			3			ns
T_A	Operating free-air temperature	-55		125	0		70	°C

¹ This applies only for 'LS162 and 'LS163, which have synchronous clear inputs.

SN54LS160A THRU SN54LS163A, SN74LS160A THRU SN74LS163A SYNCHRONOUS 4-BIT COUNTERS

electrical characteristics over recommended operating free-air temperature range (unless otherwise noted)

PARAMETER		TEST CONDITIONS†	SN54LS*			SN74LS*			UNIT
			MIN	TYP‡	MAX	MIN	TYP‡	MAX	
V _{IH}	High-level input voltage		2			2			V
V _{IL}	Low-level input voltage		0.7			0.8			V
V _{IK}	Input clamp voltage	V _{CC} = MIN, I _I = -18 mA	-1.5			-1.5			V
V _{OH}	High-level output voltage	V _{CC} = MIN, V _{IH} = 2 V, V _{IL} = V _{IL max} , I _{OH} = -400 µA	2.5	3.4		2.7	3.4		V
V _{OL}	Low-level output voltage	V _{CC} = MIN, V _{IH} = 2 V, V _{IL} = V _{IL max}	I _{OL} = 4 mA		0.25	0.4	0.25	0.4	V
			I _{OL} = 8 mA				0.35	0.5	
I _I	Input current at maximum input voltage	Data or ENP	V _{CC} = MAX, V _I = 7 V			0.1			0.1
		LOAD, CLK, or ENT				0.2			0.2
		CLR ('LS160A, 'LS161A)				0.1			0.1
		CLR ('LS162A, 'LS163A)				0.2			0.2
I _{IH}	High-level input current	Data or ENP	V _{CC} = MAX, V _I = 2.7 V			20			20
		LOAD, CLK, or ENT				40			40
		CLR ('LS160A, 'LS161A)				20			20
		CLR ('LS162A, 'LS163A)				40			40
I _{IL}	Low-level input current	Data or ENP	V _{CC} = MAX, V _I = 0.4 V			-0.4			-0.4
		LOAD, CLK, or ENT				-0.8			-0.8
		CLR ('LS160A, 'LS161A)				-0.4			-0.4
		CLR ('LS162A, 'LS163A)				-0.8			-0.8
I _{OS}	Short-circuit output current §	V _{CC} = MAX	-20	-100	-20	-100		mA	
I _{CCH}	Supply current, all outputs high	V _{CC} = MAX, See Note 3	18	31	18	31		mA	
I _{CCL}	Supply current, all outputs low	V _{CC} = MAX, See Note 4	19	32	19	32		mA	

† For conditions shown as MIN or MAX, use the appropriate value specified under recommended operating conditions.

‡ All typical values are at V_{CC} = 5 V, T_A = 25°C.

§ Not more than one output should be shorted at a time, and duration of the short-circuit should not exceed one second.

NOTES: 3. I_{CCH} is measured with the load input high, then again with the load input low, with all other inputs high and all outputs open.

4. I_{CCL} is measured with the clock input high, then again with the clock input low, with all other inputs low and all outputs open.

switching characteristics, V_{CC} = 5 V, T_A = 25°C

PARAMETER¶	FROM (INPUT)	TO (OUTPUT)	TEST CONDITIONS	MIN	TYP	MAX	UNIT
f _{max}			C _L = 15 pF, R _L = 2 kΩ, See figures 1 and 2 and Note 8	25	32		MHz
t _{PLH}	CLK	RCO			20	35	ns
t _{PHL}		Any			18	35	
t _{PLH}	CLK	Any			13	24	ns
t _{PHL}	(LOAD input high)	Q			18	27	
t _{PLH}	CLK	Any			13	24	ns
t _{PHL}	(LOAD input low)	Q			18	27	
t _{PLH}	ENT	RCO			9	14	ns
t _{PHL}		Any Q			9	14	
t _{PHL}	CLR	Any Q			20	28	ns

¶ f_{max} = Maximum clock frequency

t_{PLH} = propagation delay time, low-to-high-level output.

t_{PHL} = propagation delay time, high-to-low-level output.

NOTE 8: Propagation delay for clearing is measured from the clear input for the 'LS160A and 'LS161A or from the clock transition for the 'LS162A and 'LS163A.

3

TTL DEVICES

SN54S162, SN54S163, SN74S162, SN74S163 SYNCHRONOUS 4-BIT COUNTERS

schematics of inputs and outputs

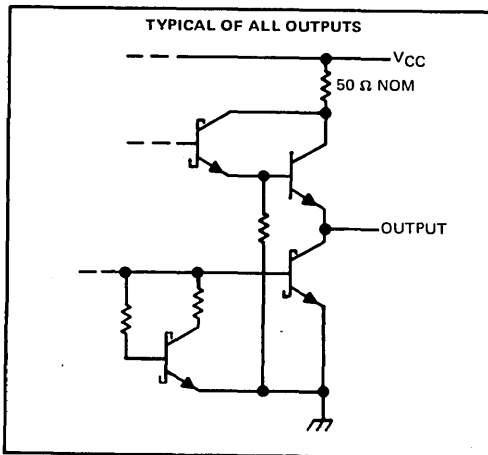
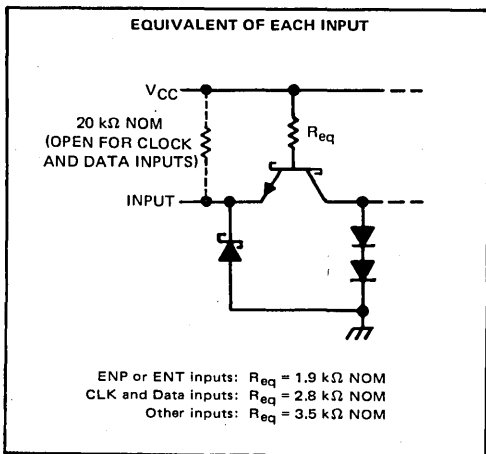

absolute maximum ratings over operating free-air temperature range (unless otherwise noted)

Supply voltage, V_{CC} (see Note 1)	7 V
Input voltage	5.5 V
Interemitter voltage (see Note 2)	5.5 V
Operating free-air temperature range: SN54S162, SN54S163 (see Note 10)	-55°C to 125°C
SN74S162, SN74S163	0°C to 70°C
Storage temperature range	-65°C to 150°C

recommended operating conditions

	SN54S162, SN54S163			SN74S162, SN74S163			UNIT
	MIN	NOM	MAX	MIN	NOM	MAX	
Supply voltage, V_{CC}	4.5	5	5.5	4.75	5	5.25	V
High-level output current, I_{OH}			-1			-1	mA
Low-level output current, I_{OL}			20			20	mA
Clock frequency, f_{clock}	0		40	0		40	MHz
Width of clock pulse, $t_{w(clock)}$ (high or low)	10			10			ns
Width of clear pulse, $t_{w(clear)}$	10			10			ns
Setup time, t_{su} (see Figure 4)	Data inputs, A, B, C, D	4		4			ns
	ENP or ENT	12		12			
	\overline{LOAD}	14		14			
	\overline{CLR}	14		14			
	\overline{LOAD} inactive-state	12		12			
	\overline{CLR} inactive-state	12		12			
Release time, $t_{release}$ (see Figure 4)			4			4	ns
Hold time, t_h (see Figure 4)	Data inputs A, B, C, D	3		3			ns
	\overline{LOAD}	0		0			
	\overline{CLR}	0		0			
Operating free-air temperature, T_A (see Note 10)			125			70	°C

- NOTES: 1. Voltage values, except interemitter voltage, are with respect to network ground terminal.
 2. This is the voltage between two emitters of a multiple-emitter transistor. For these circuits, this rating applies between the count enable inputs P and T.
 10. An SN54S162 or SN54S163 in the W package operating at free air temperatures above 91°C requires a heat sink that provides a thermal resistance from case to free-air, $R_{\theta CA}$, of not more than 26°C/W.

3 TTL DEVICES

SN54S162, SN54S163, SN74S162, SN74S163 SYNCHRONOUS 4-BIT COUNTERS

electrical characteristics over recommended operating free-air temperature range (unless otherwise noted)

PARAMETER	TEST CONDITIONS [†]	SN54S162 SN54S163		SN74S162 SN74S163		UNIT
		MIN	TYP [‡] MAX	MIN	TYP [‡] MAX	
V _{IH} High-level input voltage		2		2		V
V _{IL} Low-level input voltage			0.8		0.8	V
V _{IF} Input clamp voltage	V _{CC} = MIN, I _I = -18 mA		-1.2		-1.2	V
V _{OH} High-level output voltage	V _{CC} = MIN, V _{IH} = 2 V, V _{IL} = 0.8 V, I _{OH} = -1 mA	2.5	3.4	2.7	3.4	V
V _{OL} Low-level output voltage	V _{CC} = MIN, V _{IH} = 2 V, V _{IL} = 0.8 V, I _{OL} = 20 mA		0.5		0.5	V
I _I Input current at maximum input voltage	V _{CC} = MAX, V _I = 5.5 V		1		1	mA
I _{IH} High-level input current	CLK and data inputs		50		50	μA
	Other inputs		-10	-200	-10	
I _{IL} Low-level input current	ENT		-4		-4	mA
	Other inputs		-2		-2	
I _{OS} Short-circuit output current [§]	V _{CC} = MAX	-40	-100	-40	-100	mA
I _{CC} Supply current	V _{CC} = MAX		95 160		95 160	mA

[†]For conditions shown as MIN or MAX, use the appropriate value specified under recommended operating conditions.

[‡]All typical values are at V_{CC} = 5 V, T_A = 25° C.

[§]Not more than one output should be shorted at a time, and duration of the short-circuit should not exceed one second.

switching characteristics, V_{CC} = 5 V, T_A = 25° C

PARAMETER [¶]	FROM (INPUT)	TO (OUTPUT)	TEST CONDITIONS	MIN	TYP	MAX	UNIT
f _{max}			C _L = 15 pF, R _L = 280 Ω, See Figures 1, 3, and 4	40	70		MHz
t _{PLH}	CLK	RCO			14	25	ns
t _{PHL}					17	25	
t _{PLH}	CLK	Any Q			8	15	ns
t _{PHL}					10	15	
t _{PLH}	ENT	RCO			10	15	ns
t _{PHL}					10	15	

[¶]f_{max} ≡ maximum clock frequency

t_{PLH} ≡ propagation delay time, low-to-high-level output

t_{PHL} ≡ propagation delay time, high-to-low-level output

3

TTL DEVICES

SN54160 THRU SN54163, SN54LS160A THRU SN54LS163A,
 SN54S162, SN54S163, SN74160 THRU SN74163,
 SN74LS160A THRU SN74LS163A, SN74S162, SN74S163
SYNCHRONOUS 4-BIT COUNTERS

PARAMETER MEASUREMENT INFORMATION

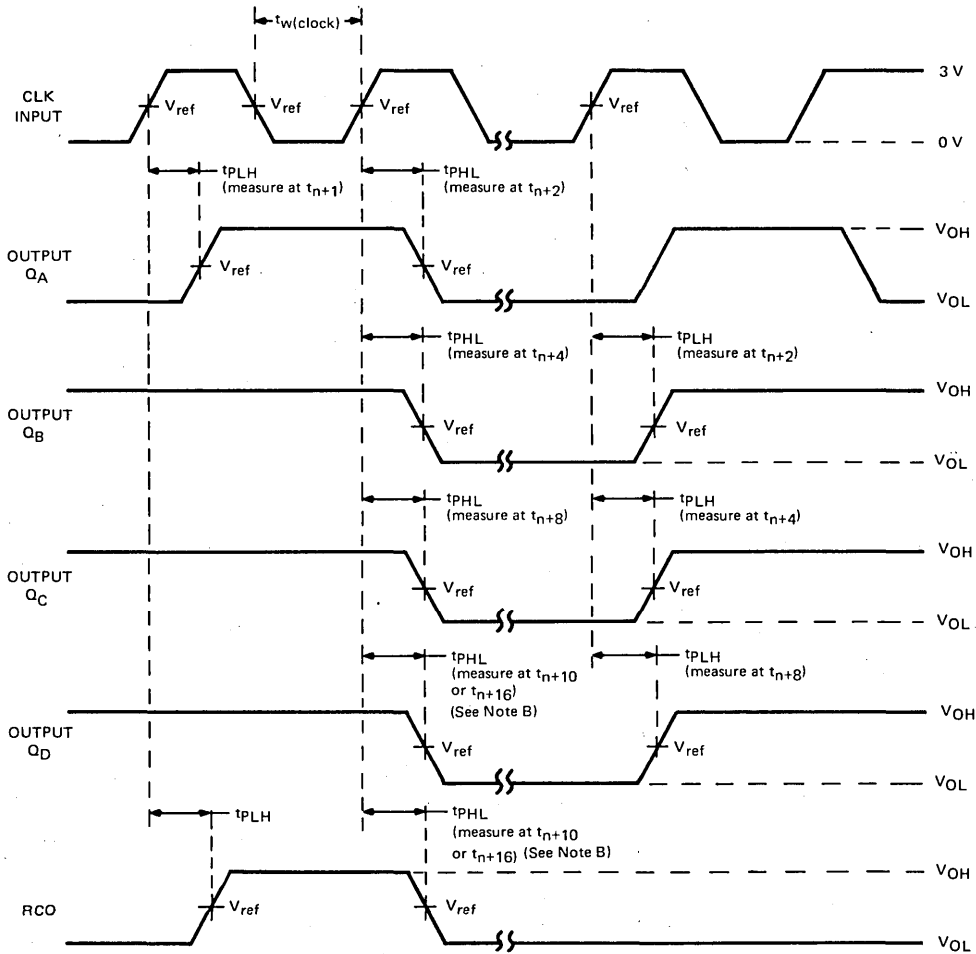

VOLTAGE WAVEFORMS

- NOTES: A. The input pulses are supplied by a generator having the following characteristics: PRR \leq 1 MHz, duty cycle \leq 50%, $Z_{\text{out}} \approx 50 \Omega$; for '160 thru '163, $t_r \leq 10$ ns, $t_f \leq 10$ ns; for 'LS160A thru 'LS163A, $t_r \leq 15$ ns, $t_f \leq 6$ ns; and for 'S162, 'S163, $t_r \leq 2.5$ ns, $t_f \leq 2.5$ ns. Vary PRR to measure f_{max} .
- B. Outputs Q_D and carry are tested at t_{n+10} for '160, '162, 'LS160A, 'LS162A, and 'S162, and at t_{n+16} for '161, '163, 'LS161A, 'LS163A, and 'S163, where t_n is the bit time when all outputs are low.
- C. For '160 thru '163, 'S162, and 'S163, $V_{\text{ref}} = 1.5$ V; for 'LS160A thru 'LS163A, $V_{\text{ref}} = 1.3$ V.

FIGURE 1—SWITCHING TIMES

SN54160 THRU SN54163, SN54LS160A THRU SN54LS163A,
SN74160 THRU SN74163, SN74LS160A, THRU SN74LS163A
SYNCHRONOUS 4-BIT COUNTERS

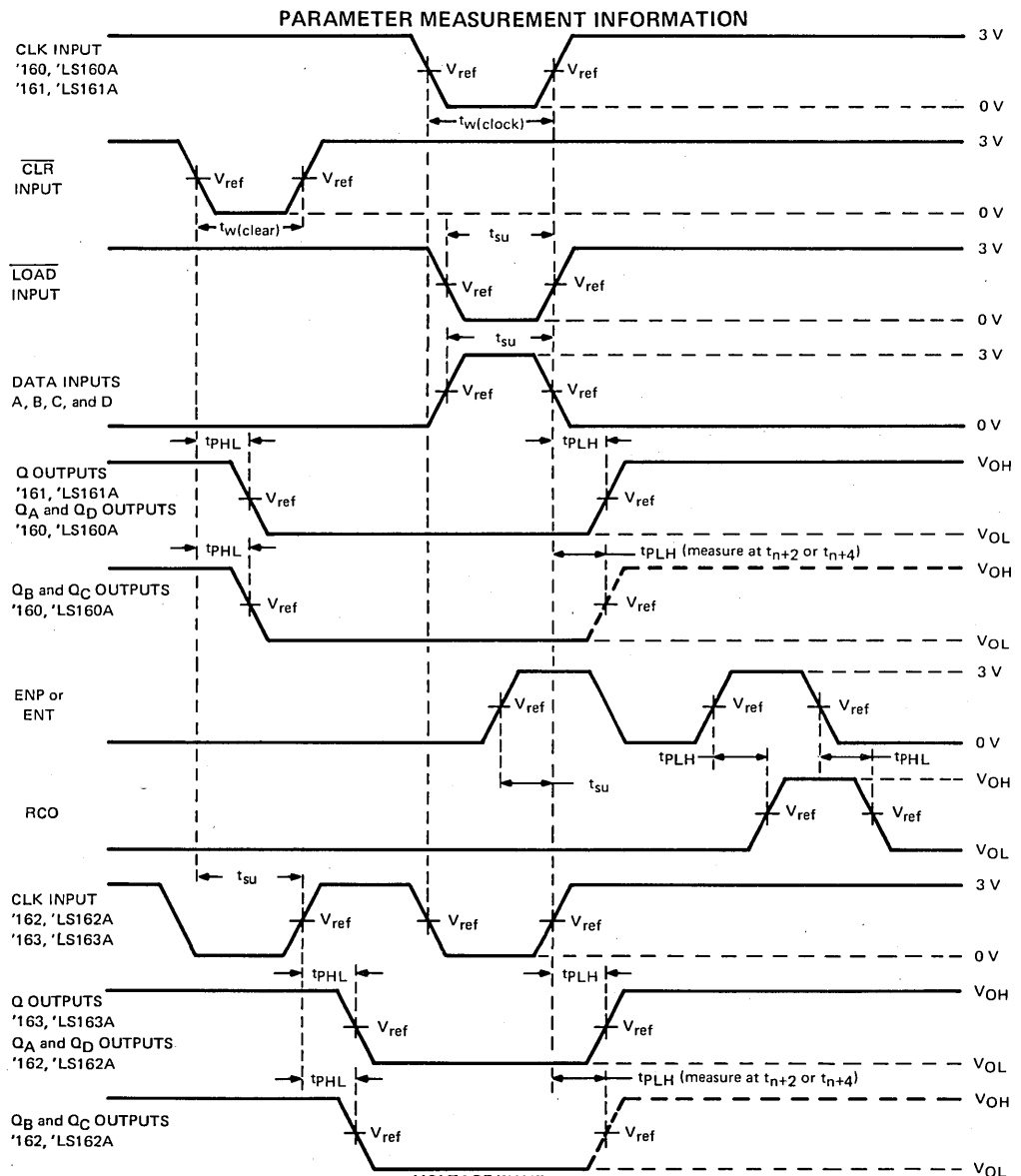

NOTES: A. The input pulses are supplied by generators having the following characteristics: PRR \leq 1 MHz, duty cycle \leq 50%, $Z_{out} \approx 50 \Omega$; for '160 thru '163, $t_r \leq 10$ ns, $t_f \leq 10$ ns; and for 'LS160A thru 'LS163A, $t_r \leq 15$ ns, $t_f \leq 6$ ns.
B. Enable P and enable T setup times are measured at t_{n+0} .
C. For '160 thru '163, $V_{ref} = 1.5$ V; for 'LS160A thru 'LS163A, $V_{ref} = 1.3$ V.

FIGURE 2—SWITCHING TIMES

3

TTL DEVICES

TYPES SN54S162, SN54S163, SN74S162, SN74S163
SYNCHRONOUS 4-BIT COUNTERS

PARAMETER MEASUREMENT INFORMATION

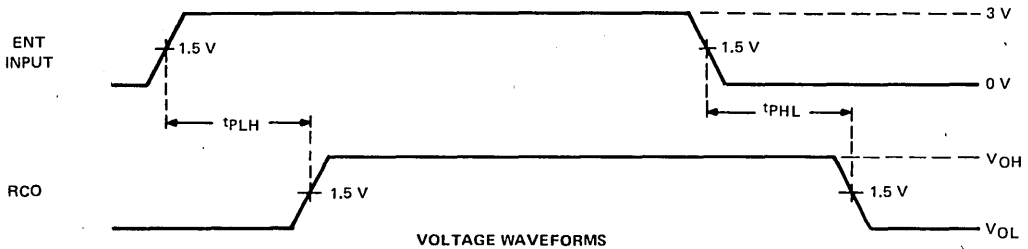

VOLTAGE WAVEFORMS

- NOTES: A. The input pulse is supplied by a generator having the following characteristics: $t_r \leq 2.5$ ns, $t_f \leq 2.5$ ns, PRR ≤ 1 MHz, duty cycle $\leq 50\%$, $Z_{out} \approx 50 \Omega$.
 B. t_{PLH} and t_{PHL} from enable T input to carry output assume that the counter is at the maximum count (Q_A and Q_D high for 'S162, all Q outputs high for 'S163).

FIGURE 3—PROPAGATION DELAY TIMES FROM ENABLE T INPUT TO CARRY OUTPUT

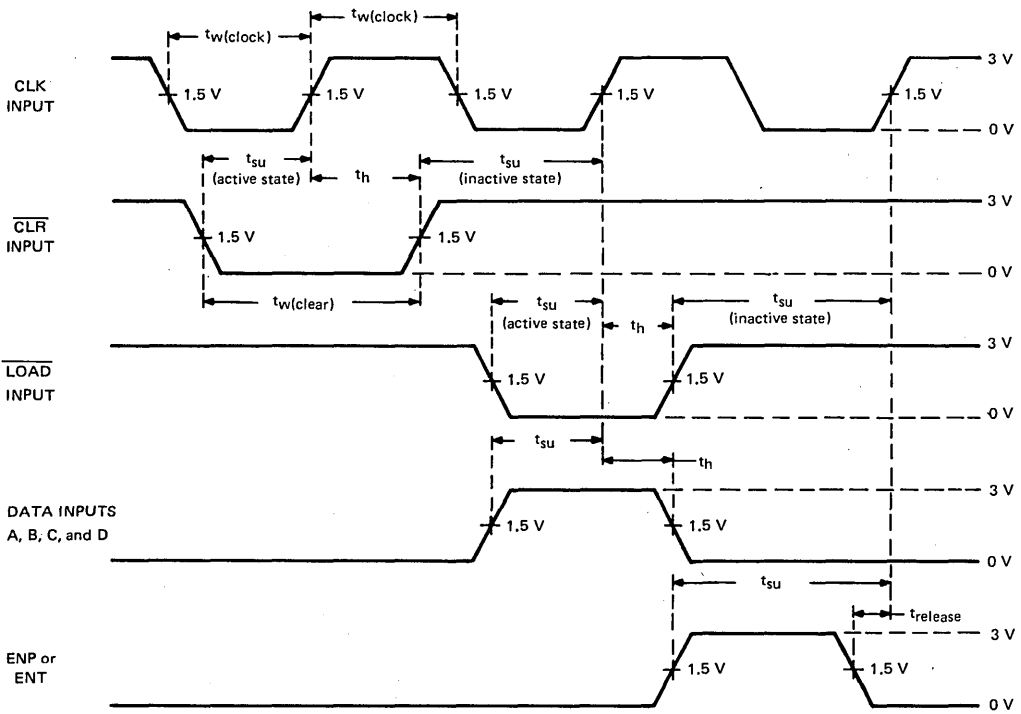

VOLTAGE WAVEFORMS

- NOTE A: The input pulses are supplied by generators having the following characteristics: $t_r \leq 2.5$ ns, $t_f \leq 2.5$ ns, PRR ≤ 1 MHz, duty cycle $\leq 50\%$, $Z_{out} \approx 50 \Omega$.

FIGURE 4—PULSE WIDTHS, SETUP TIMES, HOLD TIMES, AND RELEASE TIME

**TYPES SN54160 THRU SN54163, SN54LS160A THRU SN54LS163A,
SN54S162, SN54S163, SN74160 THRU SN74163,
SN74LS160A THRU SN74LS163A, SN74S162, SN74S163
SYNCHRONOUS 4-BIT COUNTERS**

TYPICAL APPLICATION DATA

This application demonstrates how the ripple mode carry circuit (Figure 1) and the carry-look-ahead circuit (Figure 2) can be used to implement a high-speed N-bit counter. The '160, '162, 'LS160A, 'LS162A, or 'S162 will count in BCD and the '161, '163, 'LS161A, 'LS163A, or 'S163 will count in binary. When additional stages are added the f_{MAX} decreases in Figure 1, but remains unchanged in Figure 2.

N-BIT SYNCHRONOUS COUNTERS

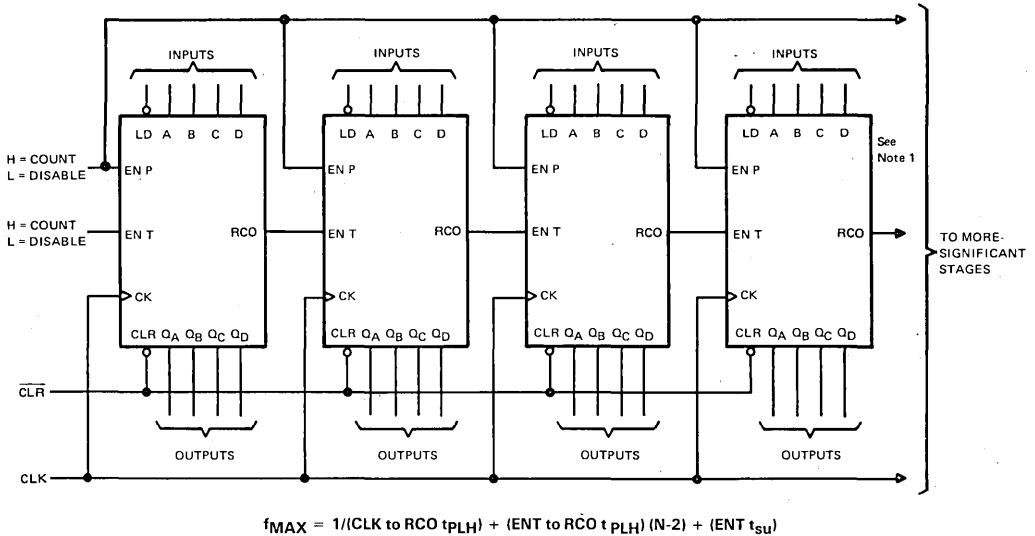

FIGURE 1



TTL DEVICES

TYPES SN54160 THRU SN54163, SN54LS160A THRU SN54LS163A,
 SN54S162, SN54S163, SN74160 THRU SN74163,
 SN74LS160A THRU SN74LS163A, SN74S162, SN74S163
 SYNCHRONOUS 4-BIT COUNTERS

TYPICAL APPLICATION DATA

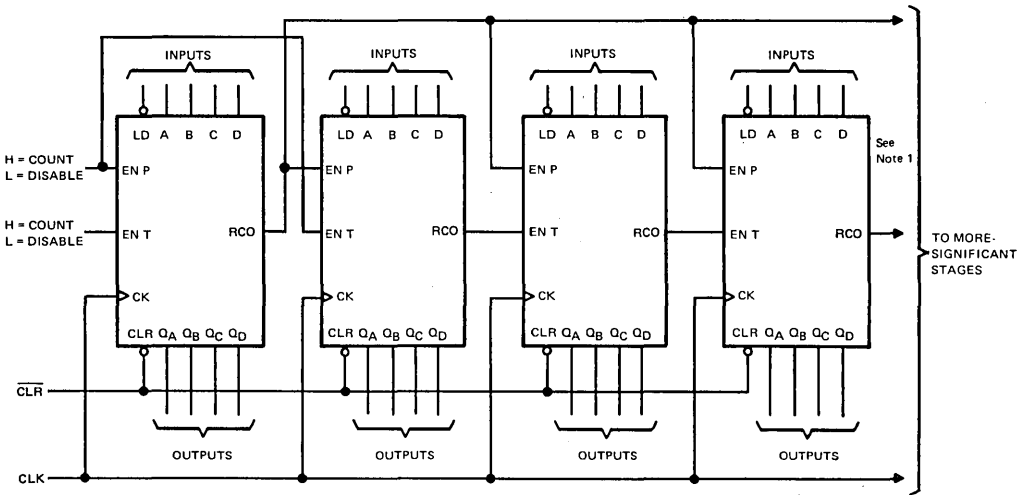

$$f_{MAX} = 1/(\text{CLK to RCO } t_{PLH}) + (\text{ENP } t_{su})$$

FIGURE 2

3

TTL DEVICES

TYPES SN54164, SN54L164, SN54LS164, SN74164, SN74LS164 8-BIT PARALLEL-OUT SERIAL SHIFT REGISTERS

MARCH 1974—REVISED DECEMBER 1983

- Gated Serial Inputs
- Fully Buffered Clock and Serial Inputs
- Asynchronous Clear

SN54164, SN54LS164 ... J OR W PACKAGE
SN54L164 ... J PACKAGE
SN74164 ... J OR N PACKAGE
SN74LS164 ... D, J OR N PACKAGE
(TOP VIEW)

TYPE	TYPICAL MAXIMUM CLOCK FREQUENCY	TYPICAL POWER DISSIPATION
'164	36 MHz	21 mW per bit
'L164	18 MHz	11 mW per bit
'LS164	36 MHz	10 mW per bit

description

These 8-bit shift registers feature gated serial inputs and an asynchronous clear. The gated serial inputs (A and B) permit complete control over incoming data as a low at either input inhibits entry of the new data and resets the first flip-flop to the low level at the next clock pulse. A high-level input enables the other input which will then determine the state of the first flip-flop. Data at the serial inputs may be changed while the clock is high or low, but only information meeting the setup-time requirements will be entered. Clocking occurs on the low-to-high-level transition of the clock input. All inputs are diode-clamped to minimize transmission-line effects.

The SN54164, SN54L164 and SN54LS164 are characterized for operation over the full military temperature range of -55°C to 125°C. The SN74164 and SN74LS164 are characterized for operation from 0°C to 70°C

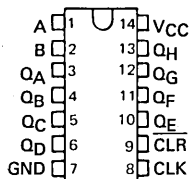

SN54LS164 ... FK PACKAGE
SN74LS164 ... FN PACKAGE
(TOP VIEW)

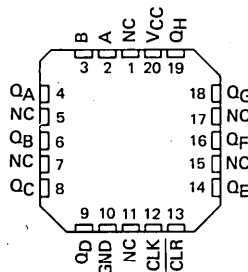

NC - No internal connection

FUNCTION TABLE

INPUTS				OUTPUTS		
CLEAR	CLOCK	A	B	QA	QB ... QH	
L	X	X	X	L	L	L
H	L	X	X	QA0	QB0	QH0
H	↑	H	H	H	QA _n	QG _n
H	↑	L	X	L	QA _n	QG _n
H	↑	X	L	L	QA _n	QG _n

H = high level (steady state), L = low level (steady state)

X = irrelevant (any input, including transitions)

↑ = transition from low to high level.

QA0, QB0, QH0 = the level of QA, QB, or QH, respectively, before the indicated steady-state input conditions were established.

QA_n, QG_n = the level of QA or QG before the most-recent ↑ transition of the clock; indicates a one-bit shift.

schematics of inputs and outputs

'164, 'L164

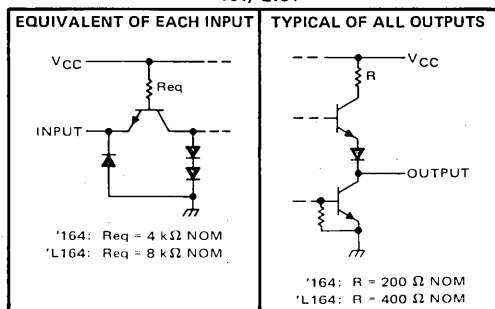

'LS164

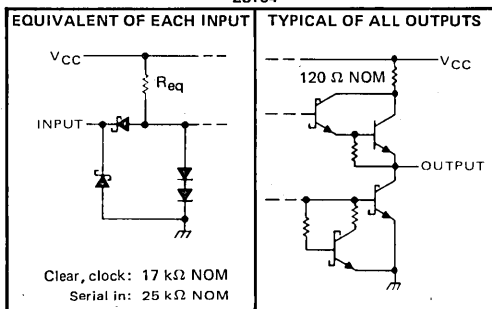

PRODUCTION DATA
This document contains information current as of publication date. Products conform to specifications per the terms of Texas Instruments standard warranty. Production processing does not necessarily include testing of all parameters.

TEXAS
INSTRUMENTS

POST OFFICE BOX 225012 • DALLAS, TEXAS 75265

3-621

TTL DEVICES

3

TYPES SN54164, SN54L164, SN54LS164, SN74164, SN74LS164
8-BIT PARALLEL-OUT SERIAL SHIFT REGISTERS

typical clear, shift, and clear sequences

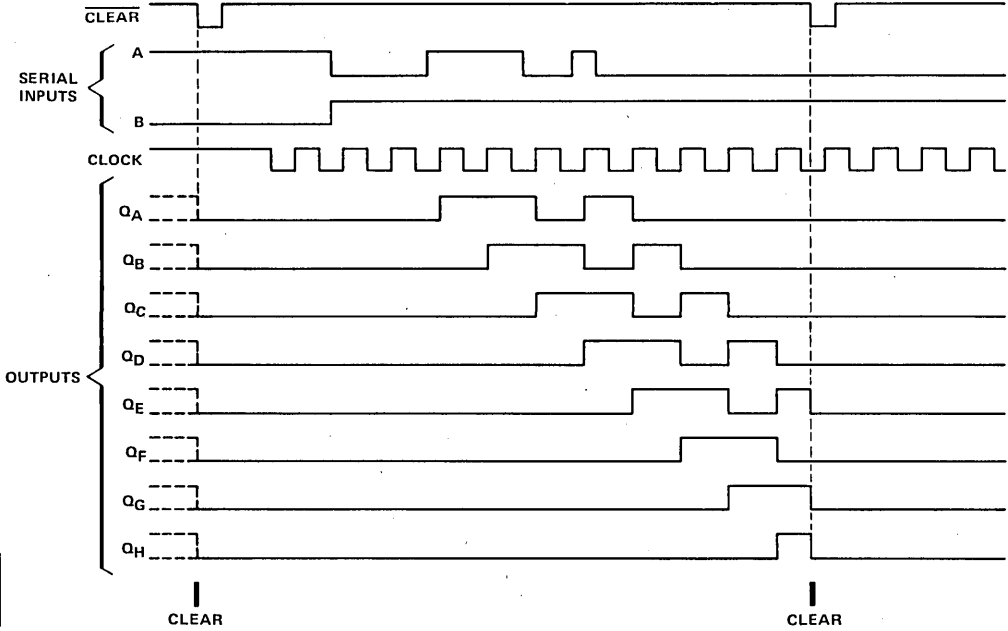

3

TTL DEVICES

TYPES SN54164, SN54L164, SN54LS164, SN74164, SN74ALS164
8-BIT PARALLEL-OUT SERIAL SHIFT REGISTERS

Logic diagram

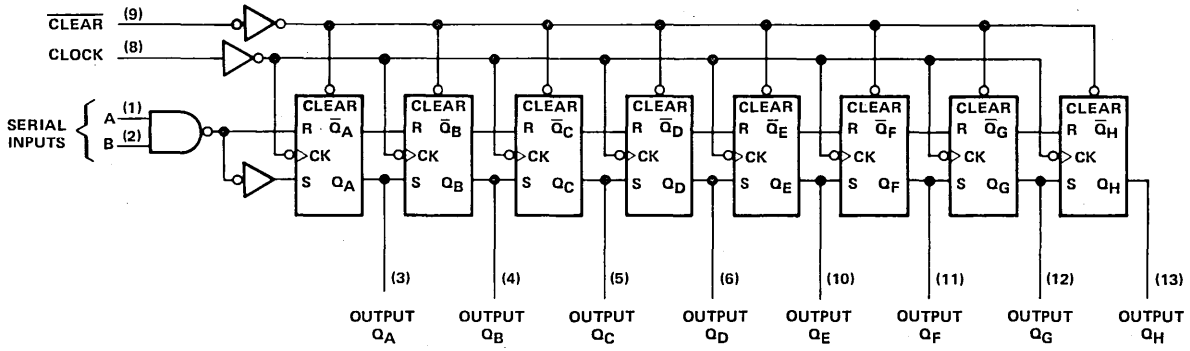

Pin numbers shown on logic notation are for D, J or N packages.

TYPES SN54164, SN74164

8-BIT PARALLEL-OUT SERIAL SHIFT REGISTERS

absolute maximum ratings over operating free-air temperature range (unless otherwise noted)

Supply voltage, V_{CC} (see Note 1)	7 V
Input voltage	5.5 V
Operating free-air temperature range: SN54164	-55°C to 125°C
SN74164	0°C to 70°C
Storage temperature range	-65°C to 150°C

NOTE 1: Voltage values are with respect to network ground terminal.

recommended operating conditions

	SN54164			SN74164			UNIT
	MIN	NOM	MAX	MIN	NOM	MAX	
Supply voltage, V_{CC}	4.5	5	5.5	4.75	5	5.25	V
High-level output current, I_{OH}			-400			-400	μ A
Low-level output current, I_{OL}			8			8	mA
Clock frequency, f_{clock}	0		25	0		25	MHz
Width of clock or clear input pulse, t_w	20			20			ns
Data setup time, t_{su} (see Figure 1)	15			15			ns
Data hold time, t_h (see Figure 1)	5			5			ns
Operating free-air temperature, T_A	-55		125	0		70	°C

electrical characteristics over recommended operating free-air temperature range (unless otherwise noted)

PARAMETER	TEST CONDITIONS†	SN54164			SN74164			UNIT
		MIN	TYP‡	MAX	MIN	TYP‡	MAX	
V_{IH} High-level input voltage		2			2			V
V_{IL} Low-level input voltage				0.8			0.8	V
V_{IK} Input clamp voltage	$V_{CC} = \text{MIN}, I_I = -12 \text{ mA}$			-1.5			-1.5	V
V_{OH} High-level output voltage	$V_{CC} = \text{MIN}, V_{IH} = 2 \text{ V}, V_{IL} = 0.8 \text{ V}, I_{OH} = -400 \mu\text{A}$	2.4	3.2		2.4	3.2		V
V_{OL} Low-level output voltage	$V_{CC} = \text{MIN}, V_{IH} = 2 \text{ V}, V_{IL} = 0.8 \text{ V}, I_{OL} = 8 \text{ mA}$		0.2	0.4		0.2	0.4	V
I_I Input current at maximum input voltage	$V_{CC} = \text{MAX}, V_I = 5.5 \text{ V}$			1			1	mA
I_{IH} High-level input current	$V_{CC} = \text{MAX}, V_I = 2.4 \text{ V}$			40			40	μ A
I_{IL} Low-level input current	$V_{CC} = \text{MAX}, V_I = 0.4 \text{ V}$			-1.6			-1.6	mA
I_{OS} Short-circuit output current§	$V_{CC} = \text{MAX}$	-10		-27.5	-9		-27.5	mA
I_{CC} Supply current	$V_{CC} = \text{MAX}, V_I(\text{clock}) = 0.4 \text{ V}$		30			30		mA
	See Note 2 $V_I(\text{clock}) = 2.4 \text{ V}$		37	54		37	54	

† For conditions shown at MIN or MAX, use the appropriate value specified under recommended operating conditions.

‡ All typical values are at $V_{CC} = 5 \text{ V}, T_A = 25^\circ\text{C}$.

§ Not more than two outputs should be shorted at a time.

NOTE 2: I_{CC} is measured with outputs open, serial inputs grounded, and a momentary ground, then 4.5 V, applied to clear.

switching characteristics, $V_{CC} = 5 \text{ V}, T_A = 25^\circ\text{C}$

PARAMETER	TEST CONDITIONS	MIN	TYP	MAX	UNIT
f_{max} Maximum clock frequency					MHz
t_{PHL} Propagation delay time, high-to-low-level Q outputs from clear input	$C_L = 15 \text{ pF}$	25	36		ns
	$C_L = 50 \text{ pF}$		24	36	
t_{PLH} Propagation delay time, low-to-high-level Q outputs from clock input	$C_L = 15 \text{ pF}$	8	17	27	ns
	$C_L = 50 \text{ pF}$	10	20	30	
t_{PHL} Propagation delay time, high-to-low-level Q outputs from the clock input	$C_L = 15 \text{ pF}$	10	21	32	ns
	$C_L = 50 \text{ pF}$	10	25	37	

3

TTL DEVICES

TYPE SN54L164

8-BIT PARALLEL-OUT SERIAL SHIFT REGISTER

absolute maximum ratings over operating free-air temperature range (unless otherwise noted)

Supply voltage, V_{CC} (see Note 1)	7 V
Input voltage	5.5 V
Operating free-air temperature range: SN54L164	-55°C to 125°C
Storage temperature range	-65°C to 150°C

NOTE 1: Voltage values are with respect to network ground terminal.

recommended operating conditions

	MIN	NOM	MAX	UNIT
V_{CC} Supply voltage	4.5	5	5.5	V
V_{IH} High-level input voltage	2			V
V_{IL} Low-level input voltage			0.8	V
I_{OH} High-level output current			-0.2	mA
I_{OL} Low-level output current			4	mA
f_{clock} Clock frequency	0		12	MHz
t_w Width of clock or clear input pulse	40			ns
t_{su} Data setup time (See Figure 1)	30			ns
t_{th} Data hold time (See Figure 1)	10			ns
T_A Operating free-air temperature	-55		125	°C

electrical characteristics over recommended operating free-air temperature range (unless otherwise noted)

PARAMETER	TEST CONDITIONS†	MIN	TYP ‡	MAX	UNIT
V_{IK}	$V_{CC} = \text{MIN}$, $I_I = -12 \text{ mA}$			-1.5	V
V_{OH}	$V_{CC} = \text{MIN}$, $V_{IH} = 2 \text{ V}$, $V_{IL} = 0.8 \text{ V}$, $I_{OH} = -0.2 \text{ mA}$	2.4	3.2		V
V_{OL}	$V_{CC} = \text{MIN}$, $V_{IH} = 2 \text{ V}$, $V_{IL} = 0.8 \text{ V}$, $I_{OL} = 4 \text{ mA}$		0.2	0.4	V
I_I	$V_{CC} = \text{MAX}$, $V_I = 5.5 \text{ V}$			1	mA
I_{IH}	$V_{CC} = \text{MAX}$, $V_I = 2.4 \text{ V}$			20	μA
I_{IL}	$V_{CC} = \text{MAX}$, $V_I = 0.4 \text{ V}$			-0.8	mA
$I_{OSS}§$	$V_{CC} = \text{MAX}$	-5		-20	mA
I_{CC}	$V_{CC} = \text{MAX}$, See Note 3		19	27	mA

† For conditions shown at MIN or MAX, use the appropriate value specified under recommended operating conditions.

‡ All typical values are at $V_{CC} = 5 \text{ V}$, $T_A = 25^\circ\text{C}$

§ Not more than two outputs should be shorted at a time.

NOTE 3: I_{CC} is measured with outputs open, serial inputs grounded, the clock input at 2.4 V, and a momentary ground, then 4.5 V, applied to clear.

switching characteristics, $V_{CC} = 5 \text{ V}$, $T_A = 25^\circ\text{C}$

PARAMETER	TEST CONDITIONS	MIN	TYP	MAX	UNIT	
f_{max} Maximum clock frequency	$R_L = 800 \Omega$, See Figure 1		12	18	MHz	
t_{PHL} Propagation delay time, high-to-low-level Q outputs from clear input		$C_L = 15 \text{ pF}$		48	72	ns
		$C_L = 50 \text{ pF}$		56	84	
t_{PLH} Propagation delay time, low-to-high-level Q outputs from clock input		$C_L = 15 \text{ pF}$		8	34	ns
		$C_L = 50 \text{ pF}$		10	20	
t_{PHL} Propagation delay time, high-to-low-level Q outputs from the clock input		$C_L = 15 \text{ pF}$		10	42	ns
	$C_L = 50 \text{ pF}$		10	50	74	

3
TTL DEVICES

TYPES SN54LS164, SN74LS164

8-BIT PARALLEL-OUT SERIAL SHIFT REGISTERS

absolute maximum ratings over operating free-air temperature range (unless otherwise noted)

Supply voltage, V_{CC} (see Note 1)	7 V
Input voltage	7 V
Operating free-air temperature range: SN54LS164	-55°C to 125°C
SN74LS164	0°C to 70°C
Storage temperature range	-65°C to 150°C

NOTE 1: Voltage values are with respect to network ground terminal.

recommended operating conditions

		SN54LS164			SN74LS164			UNIT
		MIN	NOM	MAX	MIN	NOM	MAX	
V_{CC}	Supply voltage	4.5	5	5.5	4.75	5	5.25	V
V_{IH}	High-level input voltage	2			2			V
V_{IL}	Low-level input voltage			0.7			0.8	V
I_{OH}	High-level output current			-0.4			-0.4	mA
I_{OL}	Low-level output current			4			8	mA
f_{clock}	Clock frequency	0		25	0		25	MHz
t_w	Width of clock or clear input pulse	20			20			ns
t_{su}	Data setup time (See Figure 1)	15			15			ns
t_{su}	Clear inactive setup time (See Figure 1)	15			15			ns
t_h	Data hold time (See Figure 1)	5			5			ns
T_A	Operating free-air temperature	-55		125	0		70	°C

electrical characteristics over recommended operating free-air temperature range (unless otherwise noted)

PARAMETER	TEST CONDITIONS†	SN54LS164			SN74LS164			UNIT
		MIN	TYP‡	MAX	MIN	TYP‡	MAX	
V_{IK}	$V_{CC} = \text{MIN}, I_I = -18 \text{ mA}$			-1.5			-1.5	V
V_{OH}	$V_{CC} = \text{MIN}, V_{IH} = 2 \text{ V}, V_{IL} = \text{MAX}$ $I_{OH} = -0.4 \text{ mA}$	2.5	3.5		2.7	3.5		V
V_{OL}	$V_{CC} = \text{MIN}, V_{IH} = 2 \text{ V}, V_{IL} = \text{MAX}$ $I_{OL} = 4 \text{ mA}$ $I_{OL} = 8 \text{ mA}$		0.25		0.25	0.4	0.5	V
I_I	$V_{CC} = \text{MAX}, V_I = 7 \text{ V}$			0.1			0.1	mA
I_{IH}	$V_{CC} = \text{MAX}, V_I = 2.7 \text{ V}$			20			20	μA
I_{IL}	$V_{CC} = \text{MAX}, V_I = 0.4 \text{ V}$			-0.4			-0.4	mA
I_{OS}	$V_{CC} = \text{MAX}$	-20		-100	-20		-100	mA
I_{CC}	$V_{CC} = \text{MAX}, \text{ See Note 3}$		16	27		16	27	mA

† For conditions shown as MIN or MAX, use the appropriate value specified under recommended operating conditions.

‡ All typical values are at $V_{CC} = 5 \text{ V}, T_A = 25^\circ\text{C}$.

§ Not more than one output should be shorted at a time, and duration of the short-circuit should not exceed one second.

NOTE 3: I_{CC} is measured with outputs open, serial inputs grounded, the clock input at 2.4 V, and a momentary ground, then 4.5 V applied to clear.

switching characteristics, $V_{CC} = 5 \text{ V}, T_A = 25^\circ\text{C}$

PARAMETER	TEST CONDITIONS	MIN	TYP	MAX	UNIT
f_{max}	Maximum clock frequency	25	36		MHz
t_{PHL}	Propagation delay time, high-to-low-level Q outputs from clear input		24	36	ns
t_{PLH}	Propagation delay time, low-to-high-level Q outputs from clock input		17	27	ns
t_{PHL}	Propagation delay time, high-to-low-level Q outputs from clock input		21	32	ns

TYPES SN54164, SN54L164, SN54LS164, SN74164, SN74L164, SN74LS164
8-BIT PARALLEL-OUT SERIAL SHIFT REGISTERS

PARAMETER MEASUREMENT INFORMATION

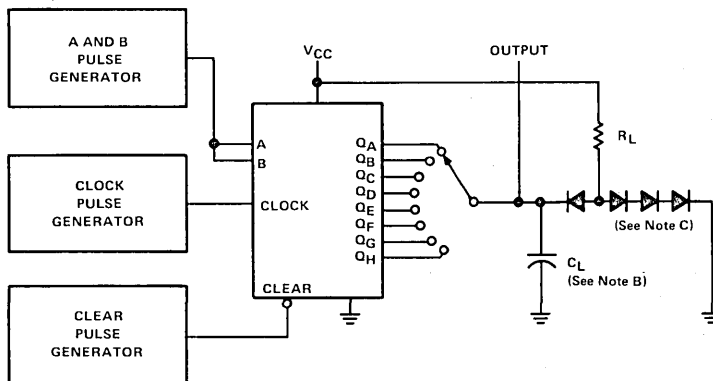

TEST CIRCUIT

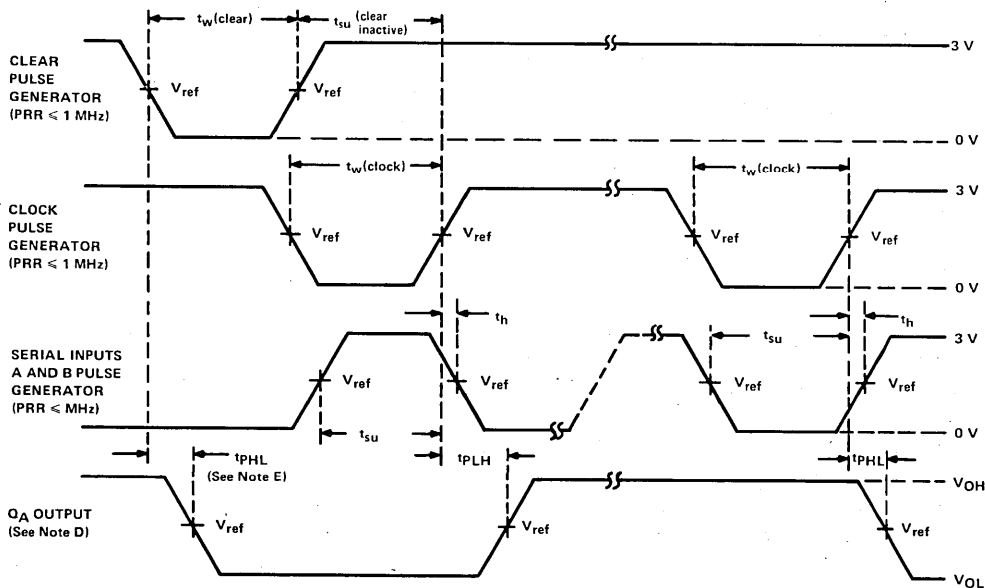

VOLTAGE WAVEFORMS

- NOTES: A. The pulse generators have the following characteristics: duty cycle $\leq 50\%$, $Z_{out} \approx 50 \Omega$; for '164 and 'L164, $t_r \leq 10$ ns, $t_f \leq 10$ ns, and for 'LS164, $t_r \leq 15$ ns, $t_f \leq 6$ ns.
 B. C_L includes probe and jig capacitance.
 C. All diodes are 1N3064 or equivalent.
 D. Q_A output is illustrated. Relationship of serial input A and B data to other Q outputs is illustrated in the typical shift sequence.
 E. Outputs are set to the high level prior to the measurement of t_{PHL} from the clear input.
 F. For '164 and 'L164, $V_{ref} = 1.5$ V; for 'LS164, $V_{ref} = 1.3$ V.

FIGURE 1—SWITCHING TIMES

TTL DEVICES

3

TTL DEVICES

TYPES SN54165, SN54LS165A, SN74165, SN74LS165A PARALLEL-LOAD 8-BIT SHIFT REGISTERS

OCTOBER 1976—REVISED APRIL 1985

- Complementary Outputs
- Direct Overriding Load (Data) Inputs
- Gated Clock Inputs
- Parallel-to-Serial Data Conversion

TYPE	TYPICAL CLOCK FREQUENCY	TYPICAL POWER DISSIPATION
'165	26 MHz	210 mW
'LS165A	35 MHz	90 mW

description

The '165 and 'LS165A are 8-bit serial shift registers that shift the data in the direction of Q_A toward Q_H when clocked. Parallel-in access to each stage is made available by eight individual direct data inputs that are enabled by a low level at the shift/load input. These registers also feature gated clock inputs and complementary outputs from the eighth bit. All inputs are diode-clamped to minimize transmission-line effects, thereby simplifying system design.

Clocking is accomplished through a 2-input positive-NOR gate, permitting one input to be used as a clock-inhibit function. Holding either of the clock inputs high inhibits clocking and holding either clock input low with the shift/load input high enables the other clock input. The clock-inhibit input should be changed to the high level only while the clock input is high. Parallel loading is inhibited as long as the shift/load input is high. Data at the parallel inputs are loaded directly into the register while the shift/load input is low independently of the levels of the clock, clock inhibit, or serial inputs.

SN54165, SN54LS165A ... J OR W PACKAGE
SN74165 ... J OR N PACKAGE
SN74LS165A ... D, J OR N PACKAGE
(TOP VIEW)

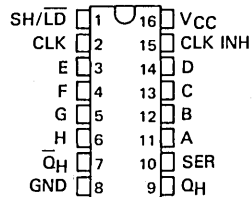

SN54LS165A ... FK PACKAGE
SN74LS165A ... FN PACKAGE
(TOP VIEW)

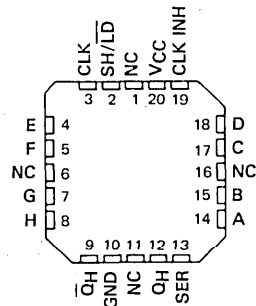

FUNCTION TABLE

INPUTS					INTERNAL OUTPUTS		OUTPUT Q_H
SHIFT/ LOAD	CLOCK INHIBIT	CLOCK	SERIAL	PARALLEL A ... H	Q_A	Q_B	
L	X	X	X	a ... h	a	b	h
H	L	L	X	X	Q_{A0}	Q_{B0}	Q_{H0}
H	L	↑	H	X	H	Q_{An}	Q_{Gn}
H	L	↑	L	X	L	Q_{An}	Q_{Gn}
H	H	X	X	X	Q_{A0}	Q_{B0}	Q_{H0}

PRODUCTION DATA
This document contains information current as of publication date. Products conform to specifications per the terms of Texas Instruments standard warranty. Product processing does not necessarily include testing of all parameters.

TEXAS
INSTRUMENTS

POST OFFICE BOX 225012 • DALLAS, TEXAS 75265

TTL DEVICES

TYPES SN54165, SN54LS165A, SN74165, SN74S165A
 PARALLEL-LOAD 8-BIT SHIFT REGISTERS

schematics of inputs and outputs

'165

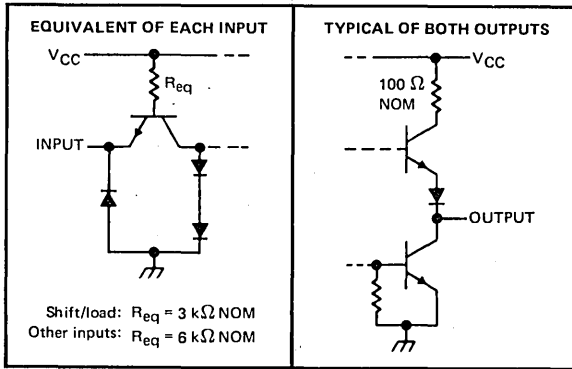

'LS165A

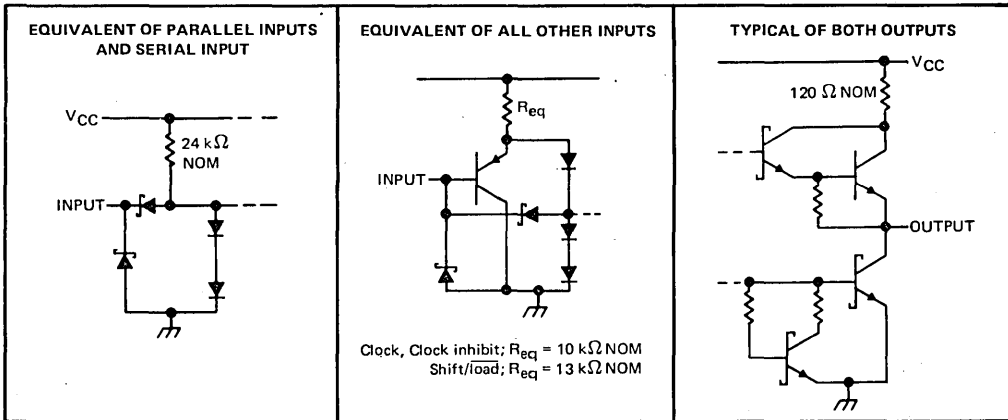

3

TTL DEVICES

TYPES SN54165, SN54LS165A, SN74165, SN74LS165A
PARALLEL-LOAD 8-BIT SHIFT REGISTERS

logic diagram (positive logic)

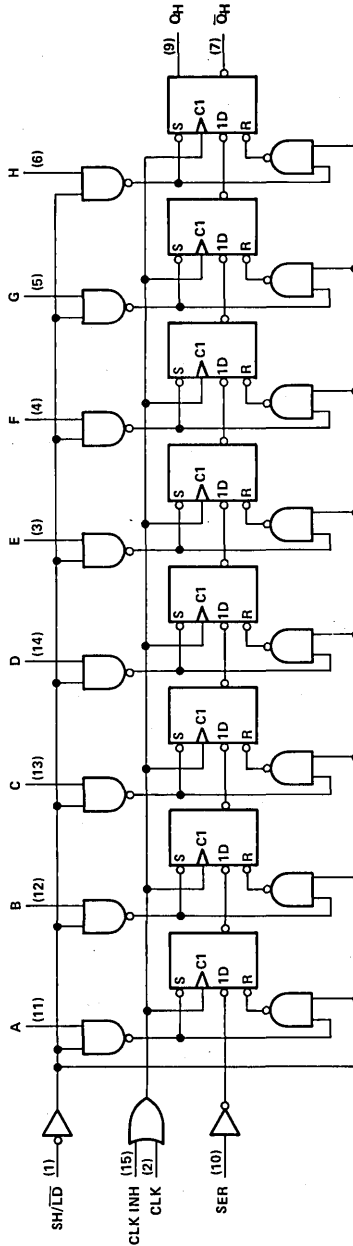

Pin numbers shown on logic notation are for D, J or N packages.

TYPES SN54165, SN74165 PARALLEL-LOAD 8-BIT SHIFT REGISTERS

recommended operating conditions

	SN54165			SN74165			UNIT
	MIN	NOM	MAX	MIN	NOM	MAX	
Supply voltage, V_{CC}	4.5	5	5.5	4.75	5	5.25	V
High-level output current, I_{OH}			-800			-800	μ A
Low-level output current, I_{OL}			16			16	mA
Clock frequency, f_{clock}	0		20	0		20	MHz
Width of clock input pulse, $t_{w(clock)}$	25			25			ns
Width of load input pulse, $t_{w(load)}$	15			15			ns
Clock-enable setup time, t_{SU} (see Figure 1)	30			30			ns
Parallel input setup time, t_{SU} (see Figure 1)	10			10			ns
Serial input setup time, t_{SU} (see Figure 2)	20			20			ns
Shift setup time, t_{SU} (see Figure 2)	45			45			ns
Hold time at any input, t_H	0			0			ns
Operating free-air temperature, T_A	-55		125	0		70	$^{\circ}$ C

electrical characteristics over recommended operating free-air temperature range (unless otherwise noted)

PARAMETER	TEST CONDITIONS†	SN54165			SN74165			UNIT
		MIN	TYP‡	MAX	MIN	TYP‡	MAX	
V_{IH} High-level input voltage		2			2			V
V_{IL} Low-level input voltage				0.8			0.8	V
V_{IK} Input clamp voltage	$V_{CC} = \text{MIN}, I_I = -12 \text{ mA}$			-1.5			-1.5	V
V_{OH} High-level output voltage	$V_{CC} = \text{MIN}, V_{IH} = 2 \text{ V}, V_{IL} = 0.8 \text{ V}, I_{OH} = -800 \mu\text{A}$	2.4	3.4		2.4	3.4		V
V_{OL} Low-level output voltage	$V_{CC} = \text{MIN}, V_{IH} = 2 \text{ V}, V_{IL} = 0.8 \text{ V}, I_{OL} = 16 \text{ mA}$		0.2	0.4		0.2	0.4	V
I_I Input current at maximum input voltage	$V_{CC} = \text{MAX}, V_I = 5.5 \text{ V}$			1			1	mA
I_{IH} High-level input current	Shift/load			80			80	μ A
	Other inputs			40			40	
I_{IL} Low-level input current	Shift/load			-3.2			-3.2	mA
	Other inputs			-1.6			-1.6	
I_{OS} Short-circuit output current §	$V_{CC} = \text{MAX}$	-20		-55	-18		-55	mA
I_{CC} Supply current	$V_{CC} = \text{MAX}, \text{ See Note 3}$		42	63		42	63	mA

NOTE 3: With the outputs open, clock inhibit and clock at 4.5 V, and a clock pulse applied to the shift/load input, I_{CC} is measured first with the parallel inputs at 4.5 V, then with the parallel inputs grounded.

† For conditions shown as MIN or MAX, use the appropriate value specified under recommended operating conditions.

‡ All typical values are at $V_{CC} = 5 \text{ V}, T_A = 25^{\circ}\text{C}$.

§ Not more than one output should be shorted at a time.

switching characteristics, $V_{CC} = 5 \text{ V}, T_A = 25^{\circ}\text{C}$

PARAMETER ¶	FROM (INPUT)	TO (OUTPUT)	TEST CONDITIONS	MIN	TYP	MAX	UNIT
f_{max}			$C_L = 15 \text{ pF}, R_L = 400 \Omega,$ See figures 1 thru 3	20	26		MHz
t_{PLH}	Load	Any			21	31	ns
t_{PHL}					27	40	
t_{PLH}	Clock	Any			16	24	ns
t_{PHL}					21	31	
t_{PLH}	H	Q_H			11	17	ns
t_{PHL}					24	36	
t_{PLH}	H	\bar{Q}_H			18	27	ns
t_{PHL}					18	27	

¶ f_{max} = maximum clock frequency

t_{PLH} = propagation delay time, low-to-high-level output

t_{PHL} = propagation delay time, high-to-low-level output

TYPES SN54LS165A, SN74LS165A PARALLEL-LOAD 8-BIT SHIFT REGISTERS

recommended operating conditions

		SN54LS165A			SN74LS165A			UNIT
		MIN	NOM	MAX	MIN	NOM	MAX	
V _{CC}	Supply voltage	4.5	5	5.5	4.75	5	5.25	V
V _{IH}	High-level input voltage	2			2			V
V _{IL}	Low-level input voltage	0.7			0.8			V
I _{OH}	High-level output current	-0.4			-0.4			mA
I _{OL}	Low-level output current	4			8			mA
f _{clock}	Clock frequency	0			25			MHz
t _{w(clock)}	Width of clock input pulse (See Figure 1)	clock high	15		15		ns	
		clock low	25		25			
t _{w(load)}	Width of load input pulse	clock high	25		25		ns	
		clock low	17		17			
t _{su}	Clock-enable setup time (See Figure 1)	30			30			ns
t _{su}	Parallel input setup time (See Figure 1)	10			10			ns
t _{su}	Serial input setup time (See Figure 2)	20			20			ns
t _{su}	Shift setup time (See Figure 2)	45			45			ns
t _h	Hold time at any input	0			0			ns
T _A	Operating free-air temperature	-55			125			°C

electrical characteristics over recommended operating free-air temperature range (unless otherwise noted)

PARAMETER	TEST CONDITIONS	SN54LS165A		SN74LS165A		UNIT
		MIN	TYP† MAX	MIN	TYP† MAX	
V _{IK}	V _{CC} = MIN, I _I = -18 mA	-1.5		-1.5		V
V _{OH}	V _{CC} = MIN, V _{IH} = 2 V, V _{IL} = MAX, I _{OH} = -0.4 mA	2.5	3.5	2.7	3.5	V
V _{OL}	V _{CC} = MIN, V _{IH} = 2 V, V _{IL} = MAX, I _{OL} = 4 mA	0.25		0.25		V
		0.4		0.4		
I _I	V _{CC} = MAX, V _I = 7 V	0.1		0.1		mA
		20		20		
I _{IH}	V _{CC} = MAX, V _I = 2.7 V	20		20		μA
I _{IL}	V _{CC} = MAX, V _I = 0.4 V	-0.4		-0.4		mA
I _{OS} ‡	V _{CC} = MAX	-20	-100	-20	-100	mA
I _{CC}	V _{CC} = MAX, See Note 3	18	30	18	30	mA

NOTE 3: With the outputs open, clock inhibit and clock at 4.5 V, and a clock pulse applied to the shift/load input, I_{CC} is measured first with the parallel inputs at 4.5 V, then with the parallel inputs grounded.

† For conditions shown as MIN or MAX, use the appropriate value specified under recommended operating conditions.

‡ All typical values are at V_{CC} = 5 V, T_A = 25°C.

§ Not more than one output should be shorted at a time, and the duration of the short-circuit should not exceed one second.

switching characteristics, V_{CC} = 5 V, T_A = 25°C

PARAMETER †	FROM (INPUT)	TO (OUTPUT)	TEST CONDITIONS	MIN	TYP	MAX	UNIT
f _{max}				25	35		MHz
‡PLH	Load	Any	R _L = 2 kΩ, C _L = 15 pF See Figures 1 thru 3	21	35		ns
‡PHL				26	35		
‡PLH	Clock	Any		14	25		ns
‡PHL				16	25		
‡PLH	H	Q _H		13	25		ns
‡PHL				24	30		
‡PLH	H	Q̄ _H		19	30		ns
‡PHL				17	25		

† f_{max} = maximum clock frequency

‡PLH = propagation delay time, low-to-high-level output

‡PHL = propagation delay time, high-to-low-level output

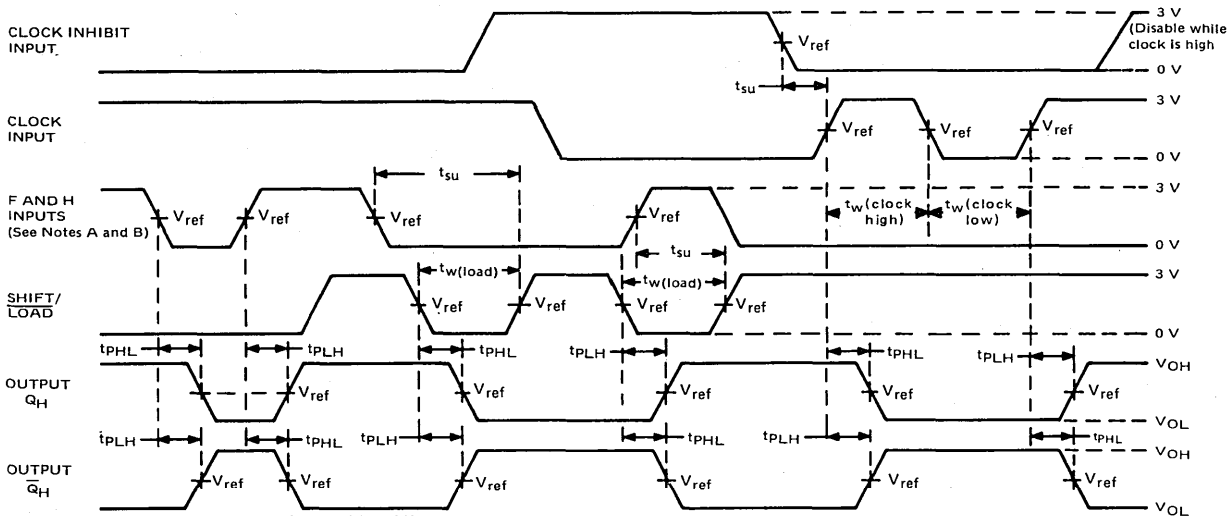

- NOTES: A. The remaining six data inputs and the serial input are low.
 B. Prior to test, high-level data is loaded into H input.
 C. The input pulse generators have the following characteristics: PRR < 1 MHz, duty cycle < 50% $Z_{out} \approx 50 \Omega$; for '165, $t_r < 10$ ns, $t_f < 10$ ns; for 'LS165A, $t_r < 15$ ns, $t_f < 6$ ns.
 D. For '165, $V_{ref} = 1.5$ V; for 'LS165A, $V_{ref} = 1.3$ V.

FIGURE 1—VOLTAGE WAVEFORMS

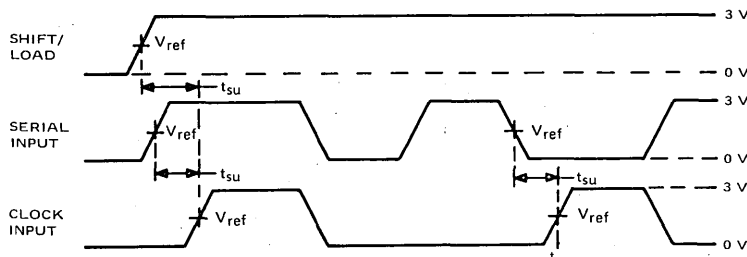

- NOTES: A. The eight data inputs and the clock-inhibit input are low. Results are monitored at output Q_H at $t_n + 7$.
 B. The input pulse generators have the following characteristics: PRR < 1 MHz, duty cycle < 50%, $Z_{out} \approx 50 \Omega$; for '165, $t_r < 10$ ns, $t_f < 10$ ns; for 'LS165A, $t_r < 15$ ns, $t_f < 6$ ns.
 C. For '165, $V_{ref} = 1.5$ V; for 'LS165A, $V_{ref} = 1.3$ V.

FIGURE 2—VOLTAGE WAVEFORMS

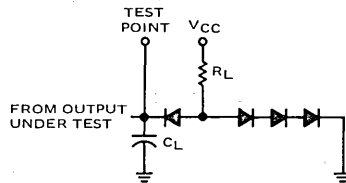

- NOTES: A. C_L includes probe and jig capacitance.
 B. All diodes are 1N3064 or equivalent.

FIGURE 3—LOAD CIRCUIT FOR SWITCHING TESTS



3

TTL DEVICES

TYPES SN54166, SN54LS166A, SN74166, SN74LS166A PARALLEL-LOAD 8-BIT SHIFT REGISTERS

OCTOBER 1976—REVISED DECEMBER 1983

- Synchronous Load
- Direct Overriding Clear
- Parallel to Serial Conversion

SN54166, SN54LS166A ... J OR W PACKAGE
SN74166 ... J OR N PACKAGE
SN74LS166A ... D, J OR N PACKAGE
(TOP VIEW)

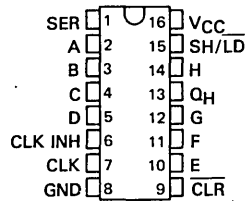

TYPE	TYPICAL CLOCK FREQUENCY	TYPICAL POWER DISSIPATION
'166	35 MHz	360 mW
'LS166A	35 MHz	100 mW

SN54LS166A ... FK PACKAGE
SN74LS166A ... FN PACKAGE
(TOP VIEW)

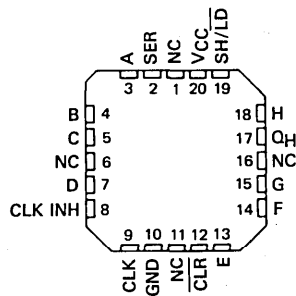

description

The '166 and 'LS166A 8-bit shift registers are compatible with most other TTL logic families. All '166 and 'LS166A inputs are buffered to lower the drive requirements to one Series 54/74 or Series 54LS/74LS standard load, respectively. Input clamping diodes minimize switching transients and simplify system design.

These parallel-in or serial-in, serial-out shift registers have a complexity of 77 equivalent gates on a monolithic chip. They feature gated clock inputs and an overriding clear input. The parallel-in or serial-in modes are established by the shift/load input. When high, this input enables the serial data input and couples the eight flip-flops for serial shifting with each clock pulse. When low, the parallel (broadside) data inputs are enabled and synchronous loading occurs on the next clock pulse. During parallel loading, serial data flow is inhibited. Clocking is accomplished on the low-to-high-level edge of the clock pulse through a two-input positive NOR gate permitting one input to be used as a clock-enable or clock-inhibit function. Holding either of the clock inputs high inhibits clocking; holding either low enables the other clock input. This, of course, allows the system clock to be free-running and the register can be stopped on command with the other clock input. The clock inhibit input should be changed to the high level only while the clock input is high. A buffered, direct clear input overrides all other inputs, including the clock, and sets all flip-flops to zero.

NC - No internal connection

FUNCTION TABLE

CLEAR	SHIFT/ LOAD	INPUTS				PARALLEL A...H	INTERNAL OUTPUTS		OUTPUT Q _H
		CLOCK INHIBIT	CLOCK	SERIAL	Q _A		Q _B		
L	X	X	X	X	X	L	L	L	
H	X	L	L	X	X	Q _{A0}	Q _{B0}	Q _{H0}	
H	L	L	↑	X	a...h	a	b	h	
H	H	L	↑	H	X	H	Q _{An}	Q _{Gn}	
H	H	L	↑	L	X	L	Q _{An}	Q _{Gn}	
H	X	H	↑	X	X	Q _{A0}	Q _{B0}	Q _{H0}	

PRODUCTION DATA
This document contains information current as of publication date. Products conform to specifications per the terms of Texas Instruments standard warranty. Production processing does not necessarily include testing of all parameters.

**TEXAS
INSTRUMENTS**

POST OFFICE BOX 225012 • DALLAS, TEXAS 75265

3

TTL DEVICES

**TYPES SN54166, SN54LS166A, SN74166, SN74LS166A
PARALLEL-LOAD 8-BIT SHIFT REGISTERS**

typical clear, shift, load, inhibit, and shift sequences

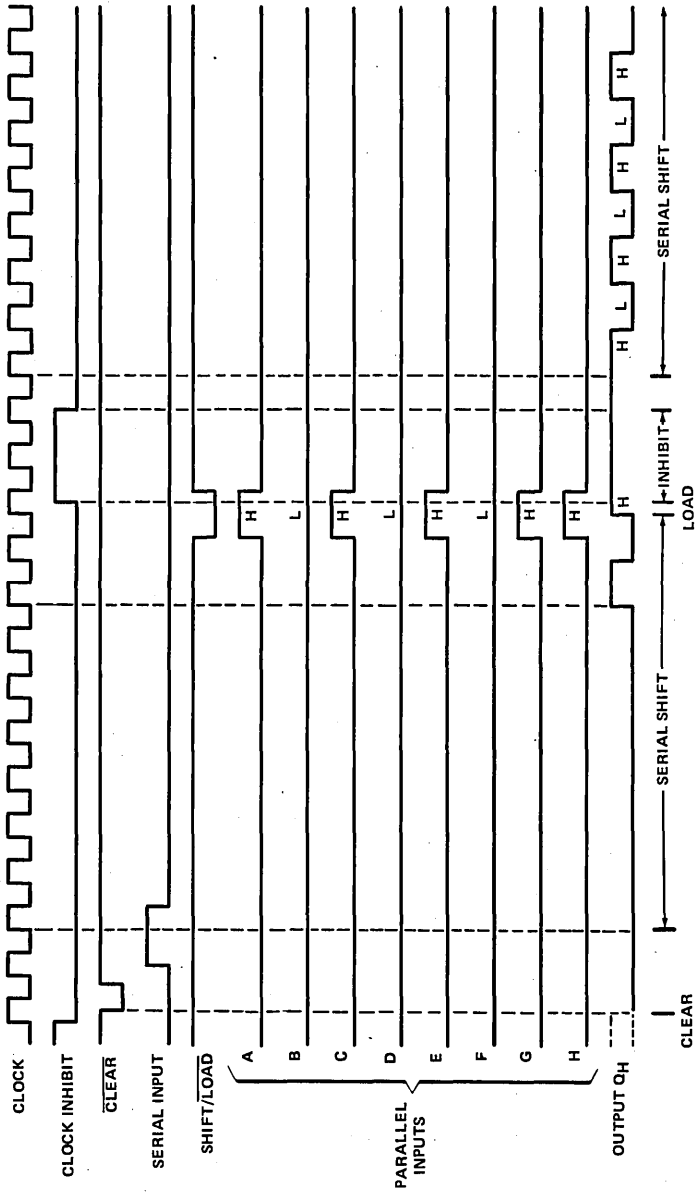

TYPES SN54166, SN54LS166A, SN74166, SN74LS166A
PARALLEL-LOAD 8-BIT SHIFT REGISTERS

schematics of inputs and outputs

'166

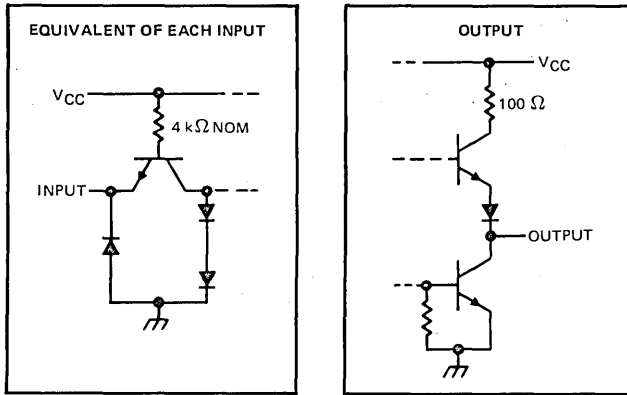

'LS166A

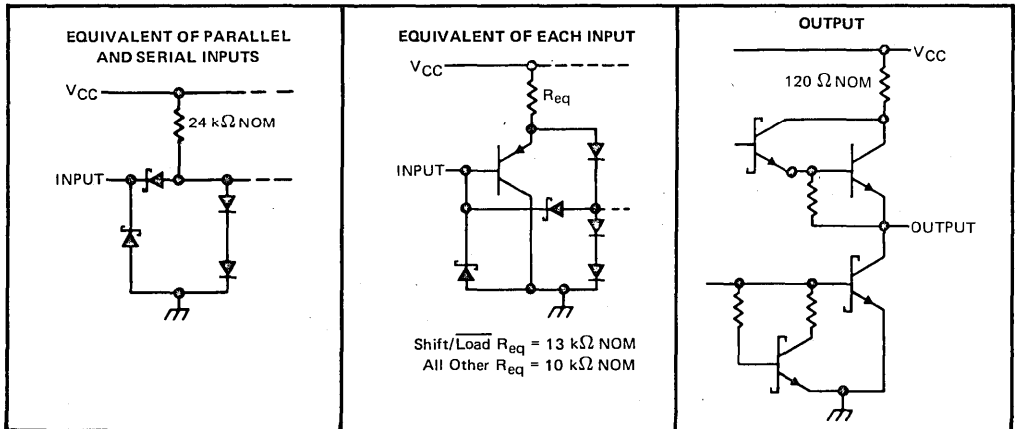

3

TTL DEVICES

TYPES SN54166, SN54LS166A, SN74166, SN74LS166A
 PARALLEL-LOAD 8-BIT SHIFT REGISTERS

logic diagram

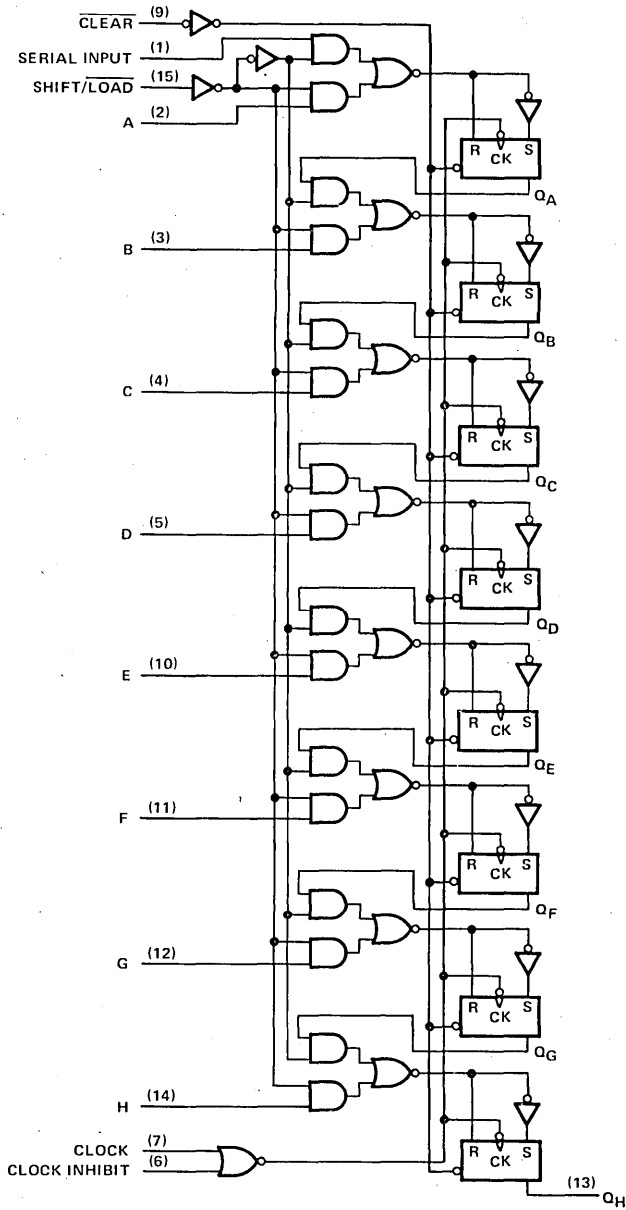

Pin numbers shown on logic notation are for D, J or N packages.

3

TTL DEVICES

TYPES SN54166, SN74166 PARALLEL-LOAD 8-BIT SHIFT REGISTERS

absolute maximum ratings over operating free-air temperature range (unless otherwise noted)

Supply voltage, V_{CC} (see Note 1)	7	V
Input voltage	5.5	V
Operating free-air temperature range: SN54166 (see Note 2)	-55°C to 125°C	
SN74166	0°C to 70°C	
Storage temperature range	-65°C to 150°C	

recommended operating conditions

	SN54166			SN74166			UNIT
	MIN	NOM	MAX	MIN	NOM	MAX	
Supply voltage, V_{CC}	4.5	5	5.5	4.75	5	5.25	V
High-level output current, I_{OH}			-800			-800	μ A
Low-level output current, I_{OL}			16			16	mA
Clock frequency, f_{clock}	0		25	0		25	MHz
Width of clock or clear pulse, t_w (see Figure 1)	20			20			ns
Mode-control setup time, t_{SU}	30			30			ns
Data setup time, t_{SD} (see Figure 1)	20			20			ns
Hold time at any input, t_H (see Figure 1)	0			0			ns
Operating free-air temperature, T_A (see Note 2)	-55		125	0		70	°C

electrical characteristics over recommended operating free-air temperature range (unless otherwise noted)

PARAMETER	TEST CONDITIONS [†]	SN54166			SN74166			UNIT
		MIN	TYP [‡]	MAX	MIN	TYP [‡]	MAX	
V_{IH} High-level input voltage		2			2			V
V_{IL} Low-level input voltage				0.8			0.8	V
V_{IK} Input clamp voltage	$V_{CC} = \text{MIN}, I_I = -12 \text{ mA}$			-1.5			-1.5	V
V_{OH} High-level output voltage	$V_{CC} = \text{MIN}, V_{IH} = 2 \text{ V}, V_{IL} = 0.8 \text{ V}, I_{OH} = -800 \mu\text{A}$	2.4	3.4		2.4	3.4		V
V_{OL} Low-level output voltage	$V_{CC} = \text{MIN}, V_{IH} = 2 \text{ V}, V_{IL} = 0.8 \text{ V}, I_{OL} = 16 \text{ mA}$		0.2	0.4		0.2	0.4	V
I_I Input current at maximum input voltage	$V_{CC} = \text{MAX}, V_I = 5.5 \text{ V}$			1			1	mA
I_{IH} High-level input current	$V_{CC} = \text{MAX}, V_I = 2.4 \text{ V}$			40			40	μ A
I_{IL} Low-level input current	$V_{CC} = \text{MAX}, V_I = 0.4 \text{ V}$			-1.6			-1.6	mA
I_{OS} Short-circuit output current [§]	$V_{CC} = \text{MAX}$	-20		-57	-18		-57	mA
I_{CC} Supply current	$V_{CC} = \text{MAX},$ See Note 3		90	127		90	127	mA

[†]For conditions shown as MIN or MAX, use the appropriate value specified under recommended operating conditions.

[‡]All typical values are at $V_{CC} = 5 \text{ V}, T_A = 25^\circ\text{C}$.

[§]Not more than one output should be shorted at a time.

NOTES: 1. Voltage values are with respect to network ground terminal.

2. An SN54166 in the W package operating at free-air temperatures above 113°C requires a heat-sink that provides a thermal resistance from case to free air, $R_{\theta CA}$, of not more than 48°C/W .

3. With all outputs open, 4.5 V applied to the serial input, all other inputs except the clock grounded, I_{CC} is measured after a momentary ground, then 4.5 V, is applied to the clock.

switching characteristics, $V_{CC} = 5 \text{ V}, T_A = 25^\circ\text{C}$

PARAMETER	TEST CONDITIONS	MIN	TYP	MAX	UNIT
f_{max} Maximum clock frequency		25	35		MHz
t_{PHL} Propagation delay time, high-to-low-level output from clear	$C_L = 15 \text{ pF}, R_L = 400 \Omega,$ See Figure 1		23	35	ns
t_{PHL} Propagation delay time, high-to-low-level output from clock			20	30	ns
t_{PLH} Propagation delay time, low-to-high-level output from clock			17	26	ns

TYPES SN54LS166A, SN74LS166A PARALLEL-LOAD 8-BIT SHIFT REGISTERS

absolute maximum ratings over operating free-air temperature range (unless otherwise noted)

Supply voltage, V_{CC} (see Note 1)	7 V
Input voltage	7 V
Operating free-air temperature range: SN54LS166A	-55°C to 125°C
SN74LS166A	0°C to 70°C
Storage temperature range	-65°C to 150°C

NOTE 1: Voltage values are with respect to network ground terminal.

recommended operating conditions

		SN54LS166A			SN74LS166A			UNIT
		MIN	TYP	MAX	MIN	TYP	MAX	
V_{CC}	Supply voltage	4.5	5	5.5	4.75	5	5.25	V
V_{IH}	High-level input voltage	2			2			V
V_{IL}	Low-level input voltage				0.8			V
I_{OH}	High-level output current				-0.4			mA
I_{OL}	Low-level output current				8			mA
f_{clock}	Clock frequency	0			25			MHz
t_w	Width of clear pulse (See Figure 1)	20			20			ns
t_w	Width of clock pulse (See Figure 1)	25			25			
t_{su}	Mode-control setup time	30			30			ns
t_{su}	Data setup time (See Figure 1)	20			20			ns
t_h	Hold time at any input (See Figure 1 and Note 4)	0			0			ns
T_A	Operating free air temperature	-55			125			°C

NOTE 4: The hold time limit of 0 ns applies only if the rise time is less than or equal to 10 ns.

electrical characteristics over recommended operating free-air temperature range (unless otherwise noted)

PARAMETER	TEST CONDITIONS †	SN54LS166A		SN74LS166A		UNIT
		MIN	TYP ‡	MAX	MIN	
V_{IK}	$V_{CC} = \text{MIN}$, $I_I = -18 \text{ mA}$			-1.5		V
V_{OH}	$V_{CC} = \text{MIN}$, $V_{IH} = 2 \text{ V}$, $V_{IL} = \text{MAX}$, $I_{OH} = -0.4 \text{ mA}$	2.5	3.4	2.7	3.4	V
V_{OL}	$V_{CC} = \text{MIN}$, $V_{IH} = 2 \text{ V}$, $V_{IL} = \text{MAX}$			0.25	0.4	V
	$I_{OL} = 4 \text{ mA}$ $I_{OL} = 8 \text{ mA}$			0.35	0.5	
I_I	$V_{CC} = \text{MAX}$, $V_I = 7 \text{ V}$			0.1	0.1	mA
I_{IH}	$V_{CC} = \text{MAX}$, $V_I = 2.7 \text{ V}$			20	20	µA
I_{IL}	$V_{CC} = \text{MAX}$, $V_I = 0.4 \text{ V}$			-0.4	-0.4	mA
$I_{OS} §$	$V_{CC} = \text{MAX}$	-20	-100	-20	-100	mA
I_{CC}	$V_{CC} = \text{MAX}$, See Note 5	20	32	20	32	mA

†For conditions shown as MIN or MAX, use the appropriate value specified under recommended operating conditions.

‡All typical values are at $V_{CC} = 5 \text{ V}$, $T_A = 25^\circ\text{C}$.

§Not more than one output should be shorted at a time, and duration for short-circuit should not exceed one second.

NOTE 5: With all outputs open, 4.5 V applied to the serial input and all other inputs except the clock grounded, I_{CC} is measured after a momentary ground, than 4.5 V, is applied to clock.

switching characteristics, $V_{CC} = 5 \text{ V}$, $T_A = 25^\circ\text{C}$

PARAMETER	TEST CONDITIONS	MIN	TYP	MAX	UNIT	
f_{max}	Maximum clock frequency	25	35		MHz	
t_{PHL}	Propagation delay time, high-to-low-level output from clear				19	ns
t_{PHL}	Propagation delay time, high-to-low-level output from clock				7	ns
t_{PLH}	Propagation delay time, low-to-high-level output from clock				5	ns

$C_L = 15 \text{ pF}$, $R_L = 2 \text{ k}\Omega$,
See Figure 1

PARAMETER MEASUREMENT INFORMATION

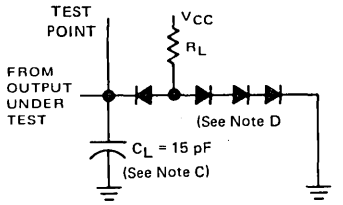

LOAD FOR OUTPUT UNDER TEST

TEST TABLE FOR SYNCHRONOUS INPUTS

DATA INPUT FOR TEST	SHIFT/LOAD	OUTPUT TESTED (SEE NOTE F)
H	0 V	Q_H at t_{n+1}
Serial Input	4.5 V	Q_H at t_{n+8}

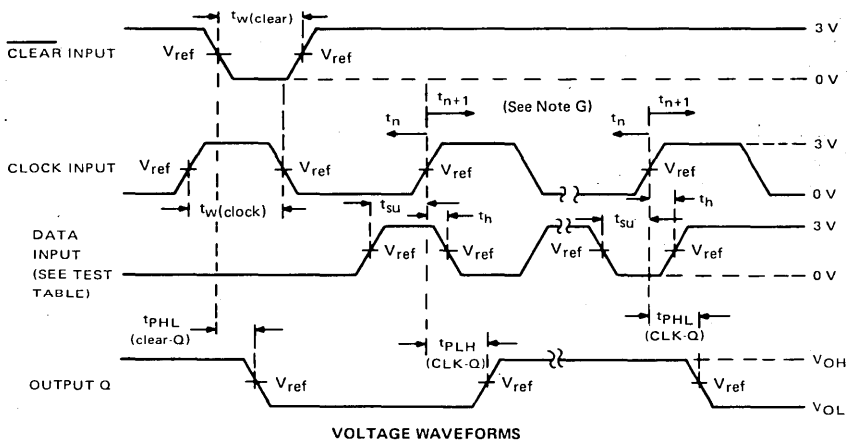

- NOTE: A. All pulse generators have the following characteristics: $Z_{out} \approx 50\Omega$; for '166, $t_r < 7$ ns and $t_f < 7$ ns; for 'LS166A, $t_r < 15$ ns and $t_f < 6$ ns.
- B. The clock pulse has the following characteristics: $t_w(\text{clock}) < 20$ ns and $PRR = 1$ MHz. The clear pulse has the following characteristics: $t_w(\text{clear}) < 20$ ns and $t_{hold} = 0$ ns. When testing f_{max} , vary the clock PRR.
- C. C_L includes probe and jig capacitance.
- D. All diodes are 1N3064, 1N916, or equivalent.
- E. A clear pulse is applied prior to each test.
- F. Propagation delay times (t_{PLH} and t_{PHL}) are measured at t_{n+1} . Proper shifting of data is verified at t_{n+8} with a functional test.
- G. t_n = bit time before clocking transition
 t_{n+1} = bit time after one clocking transition
 t_{n+8} = bit time after eight clocking transitions
- H. For '166 $V_{ref} = 1.5$ V; for 'LS166A $V_{ref} = 1.3$ V.

FIGURE 1

3
TTL DEVICES



TTL DEVICES

TYPES SN54167, SN74167 SYNCHRONOUS DECADE RATE MULTIPLIERS

DECEMBER 1972—REVISED DECEMBER 1983

- Perform Fixed-Rate or Variable-Rate Frequency Division
- For Applications in Arithmetic, Radar, Digital-to-Analog (D/A), Analog-to-Digital (A/D), and other Conversion Operations
- Typical Maximum Clock Frequency . . . 32 MHz

description

These monolithic, fully synchronous, programmable counters utilize Series 54/74 TTL circuitry to achieve 32-megahertz typical maximum operating frequencies. These decade counters feature buffered clock, clear, enable and set-to-nine inputs to control the operation of the counter, and a strobe input to enable or inhibit the rate input/decoding AND-OR-INVERT gates. The outputs have additional gating for cascading and transferring unity-count rates.

The counter is enabled when the clear, strobe set-to-nine, and enable inputs are low. With the counter enabled, the output frequency is equal to the input frequency multiplied by the rate input M and divided by 10, i.e.:

$$f_{out} = \frac{M \cdot f_{in}}{10}$$

where: $M = B_3 \cdot 2^3 + B_2 \cdot 2^2 + B_1 \cdot 2^1 + B_0 \cdot 2^0$ for decimal zero through nine.

When the rate input is binary 0 (all rate inputs low), Z remains high. In order to cascade devices to perform two-decade rate multiplication (0-99), the enable output is connected to the enable and strobe inputs of the next stage, the Z output of each stage is connected to the unity/cascade input of the other stage, and the sub-multiple frequency is taken from the Y output. For longer words, see typical application data, Figure 1.

The unity/cascade input, when connected to the clock input, may be utilized to pass the clock frequency (inverted) to the Y output when the rate input/decoding gates are inhibited by the strobe. The unity/cascade input may also be used as a control for the Y output.

All of the inputs of these counters are diode-clamped, and each input, except the clock input, represents one normalized Series 54/74 load. The buffered clock input, used with the strobe gate, is only two Series 54/74 loads. Full fan-out to 10 Series 54/74 loads is available from each of the output. These devices are completely compatible with most TTL and DTL families. Typical dissipation is 270 milliwatts. The SN54167 is characterized for operation over the full military temperature range of -55°C to 125°C , and the SN74167 is characterized for operation from 0°C to 70°C .

SN54167 . . . J OR W PACKAGE
SN74167 . . . J OR N PACKAGE
(TOP VIEW)

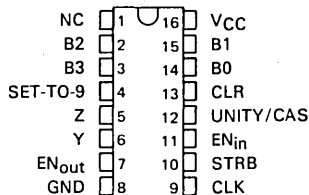

NC—No internal connection

3
TTL DEVICES

PRODUCTION DATA

This document contains information current as of publication date. Products conform to specifications per the terms of Texas Instruments standard warranty. Production processing does not necessarily include testing of all parameters.

**TEXAS
INSTRUMENTS**

POST OFFICE BOX 225012 • DALLAS, TEXAS 75265

3-645

TYPES SN54167, SN74167 SYNCHRONOUS DECADE RATE MULTIPLIERS

STATE AND/OR RATE FUNCTION TABLE (See Note A)

INPUTS							OUTPUTS				NOTES	
CLEAR	ENABLE	STROBE	BCD RATE				NUMBER OF CLOCK PULSES	UNITY/ CASCADE	LOGIC LEVEL OR NUMBER OF PULSES			
			B3	B2	B1	B0			Y	Z		ENABLE
H	X	H	X	X	X	X	X	H	L	H	H	B
L	L	L	L	L	L	L	10	H	L	H	1	C
L	L	L	L	L	L	H	10	H	1	1	1	C
L	L	L	L	L	H	L	10	H	2	2	1	C
L	L	L	L	L	H	H	10	H	3	3	1	C
L	L	L	L	H	L	L	10	H	4	4	1	C
L	L	L	L	H	L	H	10	H	5	5	1	C
L	L	L	L	H	H	L	10	H	6	6	1	C
L	L	L	L	H	H	H	10	H	7	7	1	C
L	L	L	H	L	L	L	10	H	8	8	1	C
L	L	L	H	L	L	H	10	H	9	9	1	C
L	L	L	H	L	H	L	10	H	8	8	1	C, D
L	L	L	H	L	H	H	10	H	9	9	1	C, D
L	L	L	H	H	L	L	10	H	8	8	1	C, D
L	L	L	H	H	L	H	10	H	9	9	1	C, D
L	L	L	H	H	H	L	10	H	8	8	1	C, D
L	L	L	H	H	H	H	10	H	9	9	1	C, D
L	L	L	H	L	L	H	10	L	H	9	1	E

- NOTES:
- A. H = high level, L = low level, X = irrelevant. All remaining entries are numeric counts.
 - B. This is a simplified illustration of the clear function. The states of clock and strobe can affect the logic level of Y and Z. A low unity/cascade will cause output Y to remain high.
 - C. Each rate illustrated assumes a constant value at rate inputs; however, these illustrations in no way prohibit variable-rate inputs.
 - D. These input conditions exceed the range of the decimal rate inputs.
 - E. Unity/cascade can be used to inhibit output Y.

schematics of inputs and outputs

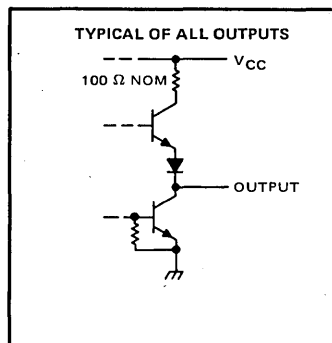
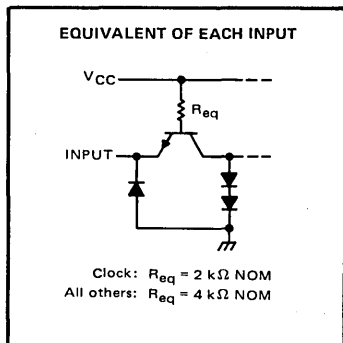

TYPES SN54167, SN74167
 SYNCHRONOUS DECADE RATE MULTIPLIERS

logic diagram

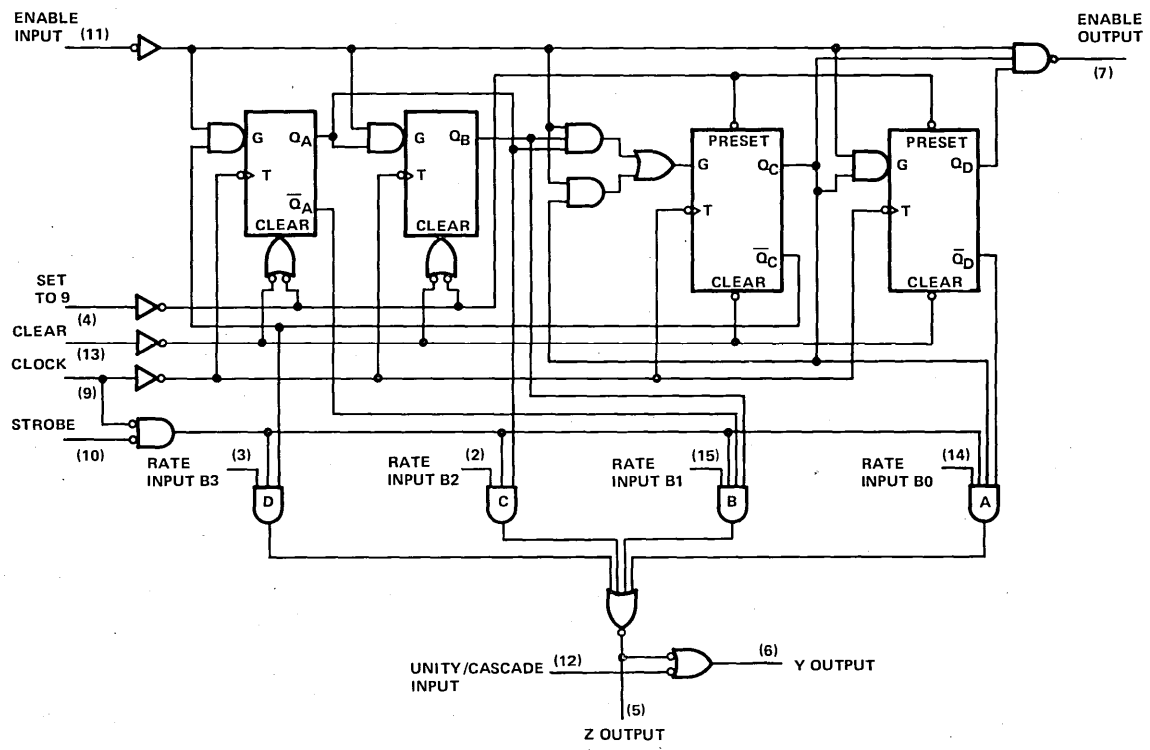

Pin numbers shown on logic notation are for J or N packages.

TEXAS INSTRUMENTS
 POST OFFICE BOX 22501 2 • DALLAS, TEXAS 75265

3-647

TTL DEVICES



TYPES SN54167, SN74167 SYNCHRONOUS DECADE RATE MULTIPLIERS

absolute maximum ratings over operating free-air temperature range (unless otherwise noted)

Supply voltage, V_{CC} (see Note 1)	7 V
Input voltage	5.5 V
Operating free-air temperature range: SN54167	-55°C to 125°C
SN74167	0°C to 70°C
Storage temperature range	-65°C to 150°C

NOTE 1: Voltage values are with respect to network ground terminal.

recommended operating conditions

	SN54167		SN74167		UNIT		
	MIN	NOM MAX	MIN	NOM MAX			
Supply voltage, V_{CC}	4.5	5	5.5	4.75 5	5.25	V	
High-level output current, I_{OH}			-400		-400	μ A	
Low-level output current, I_{OL}			16		16	mA	
Clock frequency, f_{clock}	0		25	0	25	MHz	
Width of clock pulse, $t_w(\text{clock})$	20			20		ns	
Width of clear pulse, $t_w(\text{clear})$	15			15		ns	
Width of set-to-nine pulse $t_w(\text{set-to-9})$	15			15		ns	
Enable setup time, t_{su} : From positive-going transition of clock pulse From negative-going transition of previous clock pulse	(See Note 2) 25 0			$t_w(\text{clock})-10$	0 $t_w(\text{clock})-10$	ns ns	
Enable hold time, t_h : From positive-going transition of clock pulse From negative-going transition of previous clock pulse	(See Note 2) 0 20	$t_w(\text{clock})-10$ $t_{cp}-10$			0 20	$t_w(\text{clock})-10$ $t_{cp}-10$	ns ns
Operating free-air temperature, T_A	-55	125	0		70	°C	

NOTE 2: $t_w(\text{clock})$ is the interval in which the clock is high. t_{cp} is the total clock cycle starting with a negative transition. See Figure 1 on SN5497, SN7497 data sheet.

electrical characteristics over recommended operating free-air temperature range (unless otherwise noted)

PARAMETER	TEST CONDITIONS†	MIN	TYP‡	MAX	UNIT
V_{IH} High-level input voltage		2			V
V_{IL} Low-level input voltage			0.8		V
V_I Input clamp voltage	$V_{CC} = \text{MIN}, I_I = -12 \text{ mA}$			-1.5	V
V_{OH} High-level output voltage	$V_{CC} = \text{MIN}, V_{IH} = 2 \text{ V}, V_{IL} = 0.8 \text{ V}, I_{OH} = -400 \mu\text{A}$	2.4	3.4		V
V_{OL} Low-level output voltage	$V_{CC} = \text{MIN}, V_{IH} = 2 \text{ V}, V_{IL} = 0.8 \text{ V}, I_{OL} = 16 \text{ mA}$		0.2	0.4	V
I_I Input current at maximum input voltage	$V_{CC} = \text{MAX}, V_I = 5.5 \text{ V}$			1	mA
I_{IH} High-level input current	clock input	$V_{CC} = \text{MAX}, V_I = 2.4 \text{ V}$		80	μ A
	other inputs			40	
I_{IL} Low-level input current	clock inputs	$V_{CC} = \text{MAX}, V_I = 0.4 \text{ V}$		-3.2	mA
	other inputs			-1.6	
I_{OS} Short circuit output current§	$V_{CC} = \text{MAX}$	-18		-55	mA
I_{CCH} Supply current, output high	$V_{CC} = \text{MAX},$ See Note 3		43		mA
I_{CCL} Supply current, output low	$V_{CC} = \text{MAX},$ See Note 4		65	99	mA

NOTES: 3. I_{CCH} is measured with outputs open and all inputs low.

4. I_{CCL} is measured with outputs open and all inputs high except the set-to-nine input which is low.

† For test conditions shown as MIN or MAX, use the appropriate value specified under recommended operating conditions for the applicable device type.

‡ All typical values are at $V_{CC} = 5 \text{ V}, T_A = 25^\circ \text{C}$.

§ Not more than one output should be shorted at a time.

TYPES SN54167, SN74167
 SYNCHRONOUS DECADE RATE MULTIPLIERS

switching characteristics, $V_{CC} = 5\text{ V}$, $T_A = 25^\circ\text{C}$

PARAMETERS [†]	FROM INPUT	TO OUTPUT	TEST CONDITIONS	MIN	TYP	MAX	UNIT
f_{max}			$C_L = 15\text{ pF}$, $R_L = 400\ \Omega$, See Note 5	25	32		MHz
t_{PLH}	Enable	Enable		13	20		ns
t_{PHL}	Strobe	Z		14	21		ns
t_{PLH}				12	18		
t_{PHL}	Clock	Y		15	23		ns
t_{PLH}				26	39		
t_{PHL}	Clock	Z		20	30		ns
t_{PLH}				12	18		
t_{PHL}	Rate	Z		17	26		ns
t_{PLH}				9	14		
t_{PHL}	Unity/Cascade	Y		6	10		ns
t_{PLH}				9	14		
t_{PHL}	Strobe	Y		6	10		ns
t_{PLH}				19	30		
t_{PHL}	Clock	Enable		22	33		ns
t_{PLH}				19	30		
t_{PHL}	Clear	Y		22	33		ns
t_{PLH}		Z		24	36		
t_{PHL}	Set-to-9	Enable		15	23		ns
t_{PLH}				18	27		
t_{PHL}	Any Rate Input	Y	15	23		ns	
t_{PLH}			15	23			

[†] f_{max} is maximum clock frequency.

t_{PLH} is propagation delay time, low-to-high-level output.

t_{PHL} is propagation delay time, high-to-low-level output.

NOTE 5: Load circuit, voltage waveforms, and input conditions for measuring switching characteristics are the same as those for the SN5497 and SN7497.



TTL DEVICES

This application demonstrates how the decimal-rate multipliers may be cascaded for longer words. Three decades are illustrated (0.999 to 999) although longer words can be implemented by using the pattern shown. The output is decoded either from output Y with a NOR gate or from output Z with a NAND gate. Either method of decoding produces the complement of the output used.

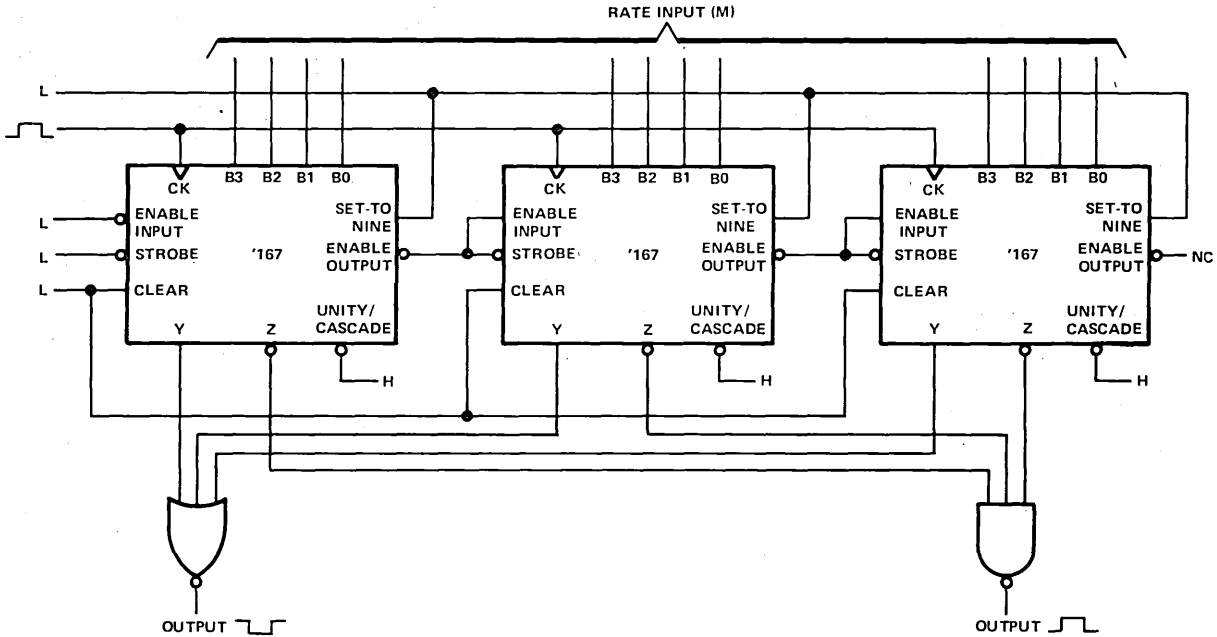

TYPES SN54LS169B, SN54S168, SN54S169, SN74LS169B, SN74S168, SN74S169 SYNCHRONOUS 4-BIT UP/DOWN COUNTERS

OCTOBER 1976—REVISED MAY 1983

'S168 . . . SYNCHRONOUS UP/DOWN DECADE COUNTERS 'LS169B, 'S169 . . . SYNCHRONOUS UP/DOWN BINARY COUNTERS

SN54S168, SN54LS169B, SN54S169 . . . J OR W PACKAGE
SN74S168, SN74LS169B, SN74S169 . . . D, J OR N PACKAGE

(TOP VIEW)

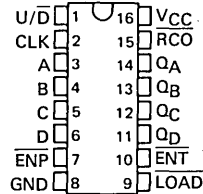

- Programmable Look-Ahead Up/Down Binary/Decade Counters
- Fully Synchronous Operation for Counting and Programming
- Internal Look-Ahead for Fast Counting
- Carry Output for n-Bit Cascading
- Fully Independent Clock Circuit

SN54S168, SN54LS169B, SN54S169 . . . FK PACKAGE
SN74S168, SN74LS169B, SN74S169 . . . FN PACKAGE

(TOP VIEW)

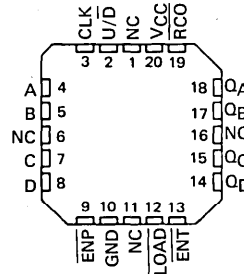

NC—No internal connection

description

These synchronous presettable counters feature an internal carry look-ahead for cascading in high speed counting applications. The 'S168 is a decade counter and the 'LS169B and 'S169 are 4-bit binary counters. Synchronous operation is provided by having all flip-flops clocked simultaneously so that the outputs change coincident with each other when so instructed by the count-enable inputs and internal gating. This mode of operation helps eliminate the output counting spikes that are normally associated with asynchronous (ripple-clock) counters. A buffered clock input triggers the four master-slave flip-flops on the rising (positive-going) edge of the clock waveform.

These counters are fully programmable; that is, the outputs may each be preset to either level. The load input circuitry allows loading with the carry-enable output of cascaded counters. As loading is synchronous, setting up a low level at the load input disables the counter and causes the outputs to agree with the data inputs after the next clock pulse.

The carry look-ahead circuitry provides for cascading counters for n-bit synchronous applications without additional gating. Instrumental in accomplishing this function are two count-enable inputs and a carry output. Both count enable inputs (ENP, ENT) must be low to count. The direction of the count is determined by the level of the up/down input. When the input is high, the counter counts up; when low, it counts down. Input ENT is fed forward to enable the carry output. The carry output thus enabled will produce a low-level output pulse with a duration approximately equal to the high portion of the QA output when counting up and approximately equal to the low portion of the QA output when counting down. This low-level overflow carry pulse can be used to enable successive cascaded stages. Transitions at the ENP or ENT inputs are allowed regardless of the level of the clock input. All inputs are diode-clamped to minimize transmission-line effects, thereby simplifying system design.

These counters feature a fully independent clock circuit. Changes at control inputs (ENP, ENT, LOAD, U/D) that will modify the operating mode have no effect until clocking occurs. The function of the counter (whether enabled, disabled, loading, or counting) will be dictated solely by the conditions meeting the stable setup and hold times.

TYPE	TYPICAL MAXIMUM CLOCK FREQUENCY		TYPICAL POWER DISSIPATION
	COUNTING UP	COUNTING DOWN	
'LS169B	35MHz	35MHz	100mW
'S168, 'S169	70MHz	55MHz	500mW

PRODUCTION DATA
This document contains information current as of publication date. Products conform to specifications per the terms of Texas Instruments standard warranty. Production processing does not necessarily include testing of all parameters.

**TEXAS
INSTRUMENTS**

POST OFFICE BOX 225012 • DALLAS, TEXAS 75265

3-651

TTL DEVICES

**TYPES SN54LS169B, SN54S168, SN54S169,
SN74LS169B, SN74S168, SN74S169
SYNCHRONOUS 4-BIT UP/DOWN COUNTERS**

logic symbols

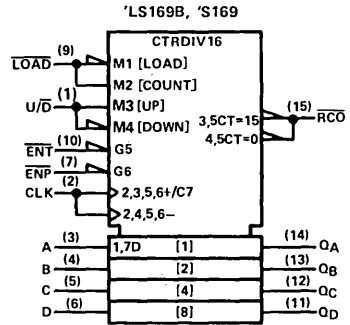
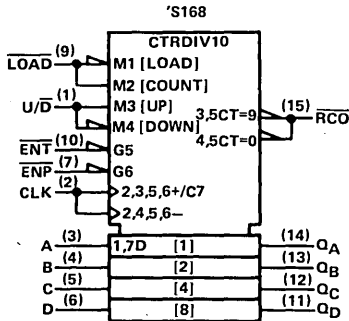

Pin numbers shown on logic notation are for D, J or N packages.

TYPES SN54S168, SN74S168
 SYNCHRONOUS 4-BIT UP/DOWN COUNTERS

logic diagram

SN54S168, SN74S168 DECADE COUNTERS

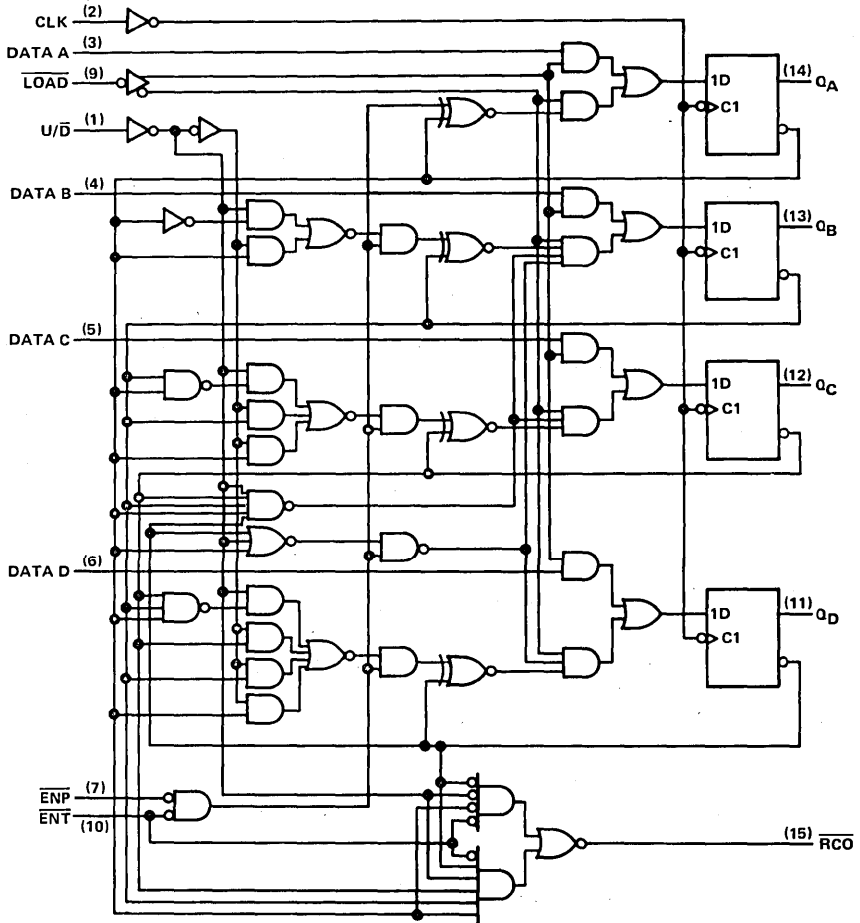

Pin numbers shown on logic notation are for D, J or N packages.

**TYPES SN54LS169B, SN74LS169B
SYNCHRONOUS 4-BIT UP/DOWN COUNTERS**

logic diagram

SN54LS169B, SN74LS169B BINARY COUNTERS

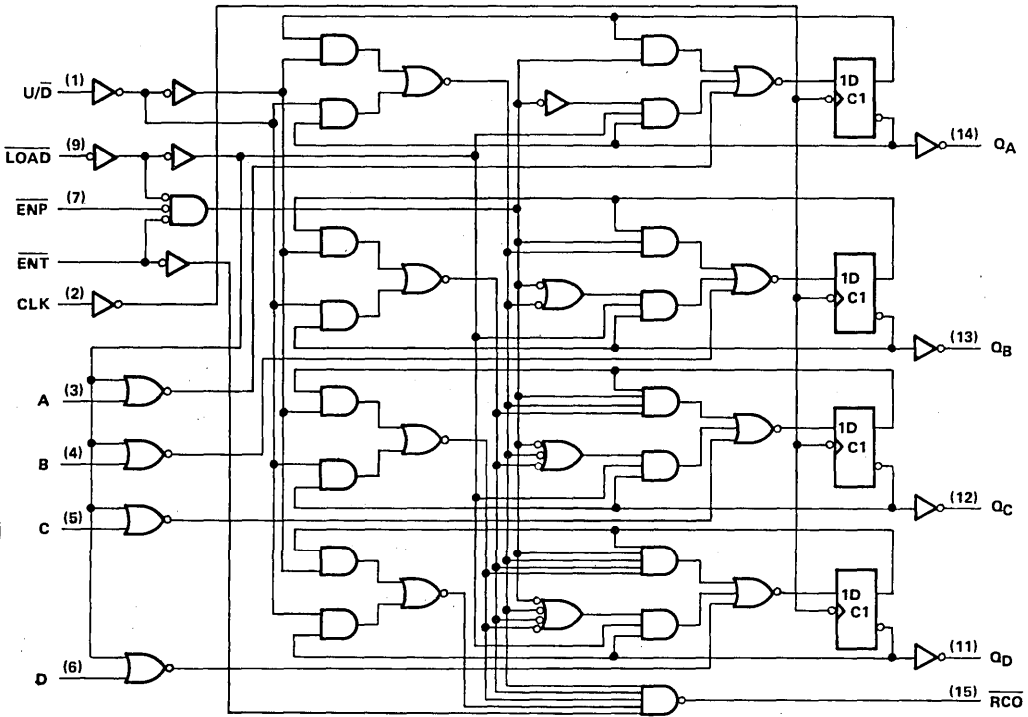

Pin numbers shown on logic notation are for D, J or N packages.

TTL DEVICES

TYPES SN54S169, SN74S169
 SYNCHRONOUS 4-BIT UP/DOWN COUNTERS

logic diagram

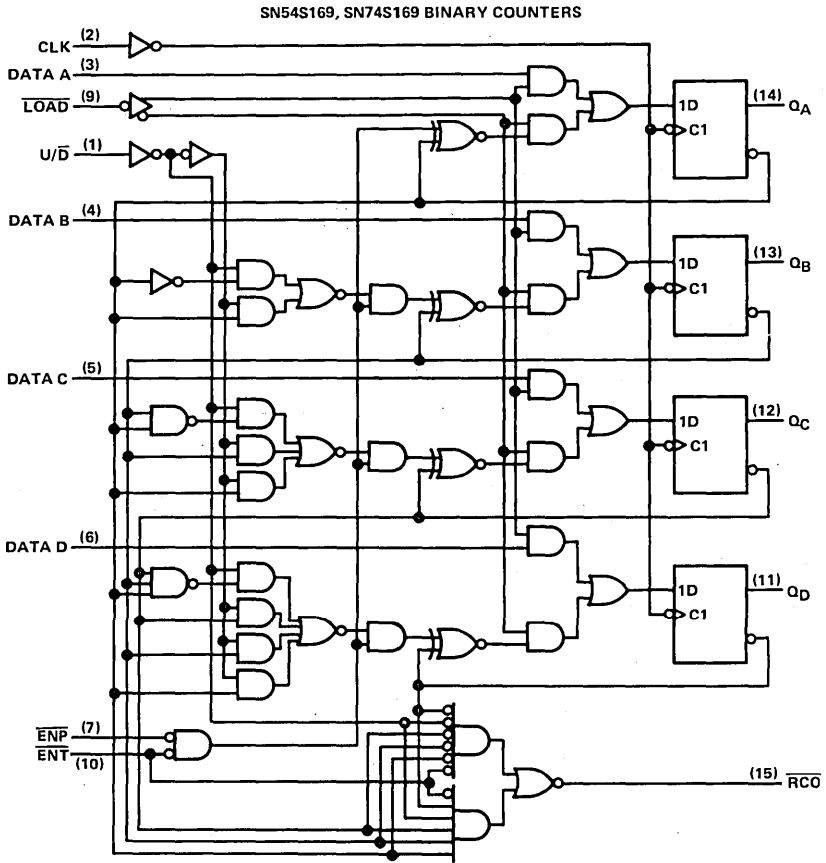

Pin numbers shown on logic notation are for D, J or N packages.

**TYPES SN54S168, SN74S168
SYNCHRONOUS 4-BIT UP/DOWN COUNTERS**

'S168 DECADE COUNTER

typical load, count, and inhibit sequences

Illustrated below is the following sequence:

1. Load (preset) to BCD seven
2. Count up to eight, nine (maximum), zero, one, and two
3. Inhibit
4. Count down to one, zero (minimum), nine, eight, and seven

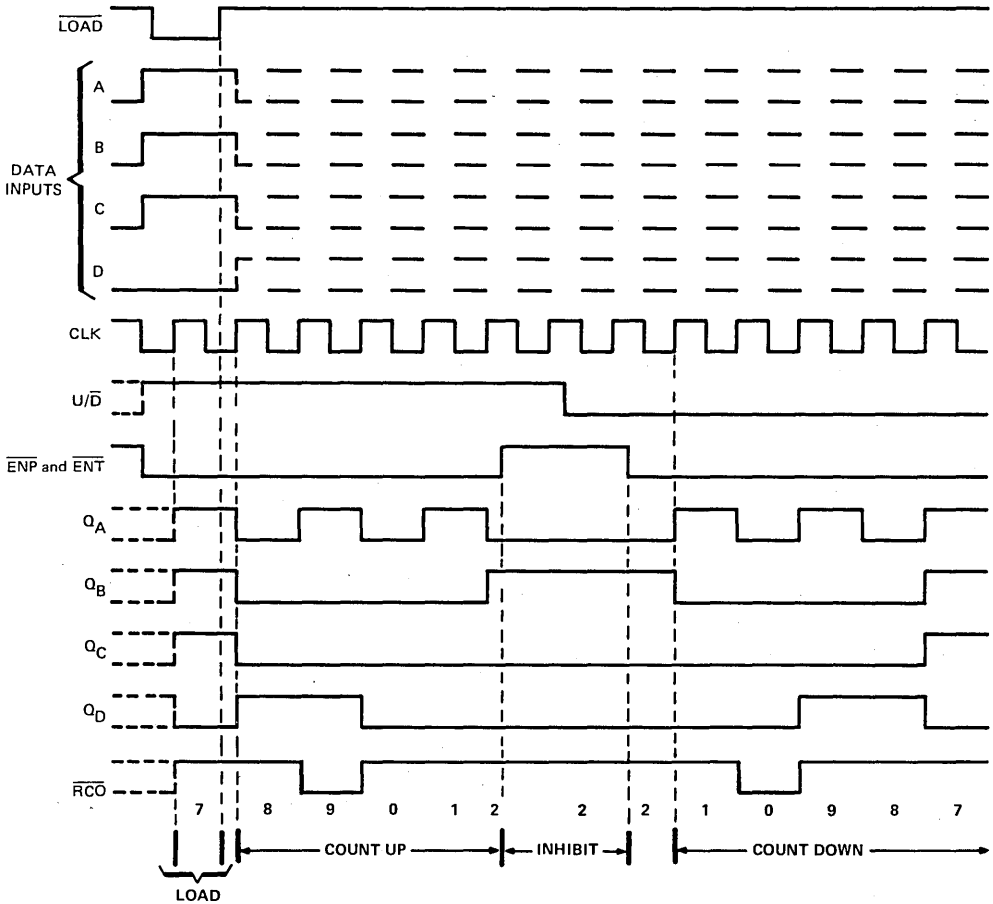

TYPES SN54LS169B, SN54S169, SN74LS169B, SN74S169
 SYNCHRONOUS 4-BIT UP/DOWN COUNTERS

'LS169B, 'S169 BINARY COUNTERS

typical load, count, and inhibit sequences

Illustrated below is the following sequence:

1. Load (preset) to binary thirteen
2. Count up to fourteen, fifteen (maximum), zero, one, and two
3. Inhibit
4. Count down to one, zero (minimum), fifteen, fourteen, and thirteen

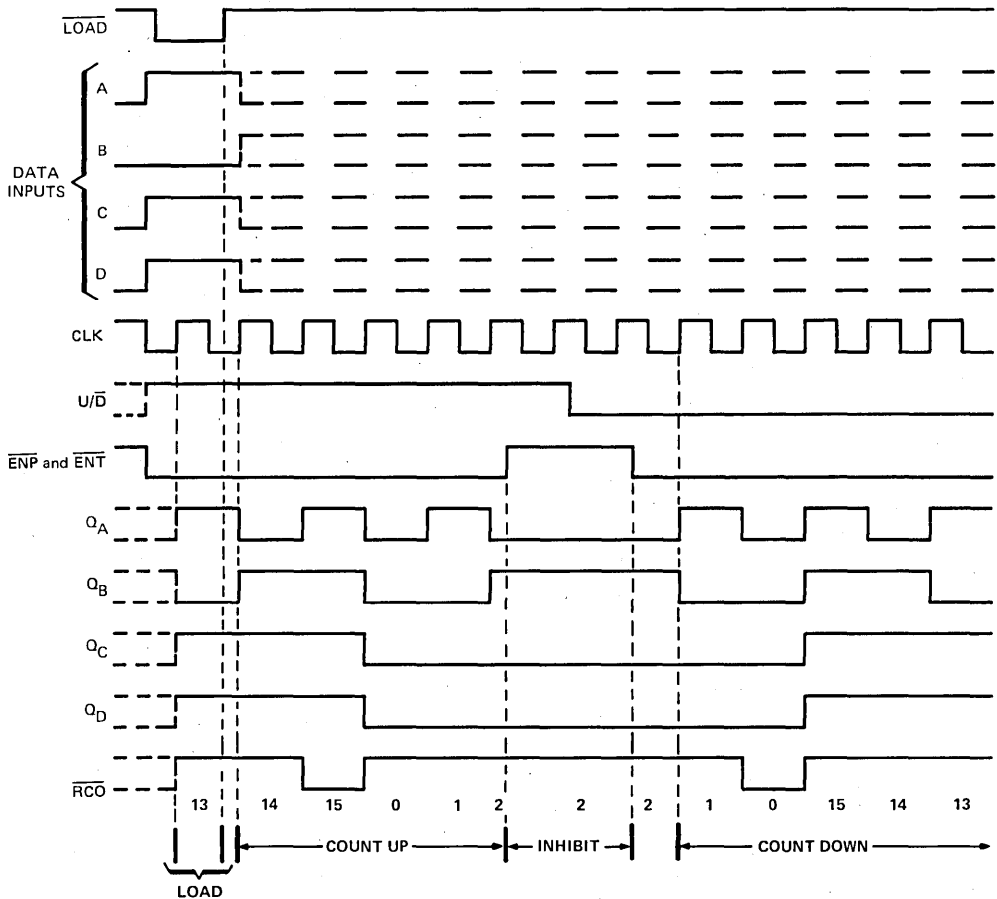

3
TTL DEVICES

TYPES SN54LS169B, SN74LS169B SYNCHRONOUS 4-BIT UP/DOWN COUNTERS

schematics of inputs and outputs

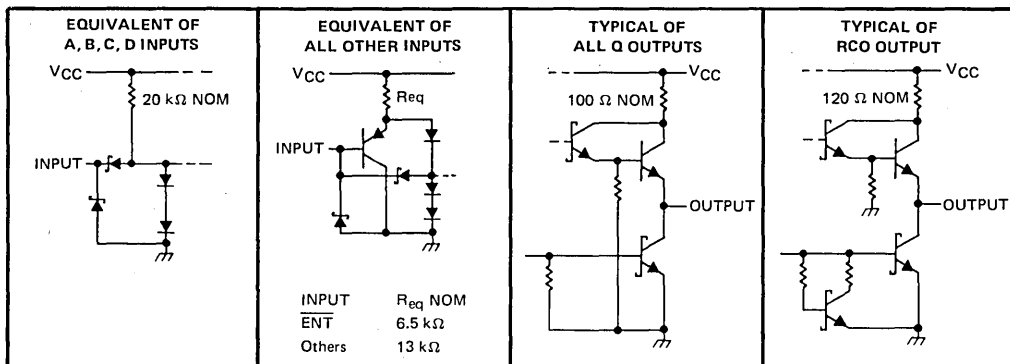

absolute maximum ratings over operating free-air temperature range (unless otherwise noted)

Supply voltage, V_{CC} (see Note 1)	7 V
Input voltage	7 V
Operating free-air temperature range: SN54LS169B	-55°C to 125°C
SN74LS169B	0°C to 70°C
Storage temperature range	-65°C to 150°C

NOTE 1: Voltage values are with respect to network ground terminal.

recommended operating conditions

		SN54LS169B			SN74LS169B			UNIT
		MIN	NOM	MAX	MIN	NOM	MAX	
V_{CC}	Supply voltage	4.5	5	5.5	4.75	5	5.25	V
V_{IH}	High-level input voltage	2			2			V
V_{IL}	Low-level input voltage	0.7			0.8			V
I_{OH}	High-level output current	RCO			-0.4			mA
		Any Q			-1.2			mA
I_{OL}	Low-level output current	RCO			4			mA
		Any Q			12			mA
f_{clock}	Clock frequency	0			0			MHz
$t_w(clock)$	Width of clock pulse (high or low) (see Figure 1)	25			25			ns
t_{su}	Setup time, (see Figure 1)	Data inputs A, B, C, D			30			ns
		ENP or ENT			30			
		Load			35			
		Up/Down			35			
t_h	Hold time at any input with respect to clock (see Figure 1)	0			0			ns
T_A	Operating free-air temperature	-55			125			°C

3

TTL DEVICES

TYPES SN54LS169B, SN74LS169B SYNCHRONOUS 4-BIT UP/DOWN COUNTERS

electrical characteristics over recommended operating free-air temperature range (unless otherwise noted)

PARAMETER	TEST CONDITIONS†		SN54LS169B			SN74LS169B			UNIT	
			MIN	TYP‡	MAX	MIN	TYP‡	MAX		
V _{IK}	V _{CC} = MIN,	I _I = -18 mA	-1.5			-1.5			V	
V _{OH}	V _{CC} = MIN, V _{IH} = 2 V, V _{IL} = MAX	\overline{RCO}	I _{OH} = -0.4 mA	2.5	3.4	2.7	3.4	V		
		Any Q	I _{OH} = -1.2 mA	2.4	3.2	2.4	3.2			
V _{OL}	V _{CC} = MIN, V _{IH} = 2 V, V _{IL} = MAX	\overline{RCO}	I _{OH} = 4 mA	0.25	0.4	0.25	0.4	V		
			I _{OL} = 8 mA			0.35	0.5			
		Any Q	I _{OL} = 12 mA	0.25	0.4	0.25	0.4			
			I _{OL} = 24 mA			0.35	0.5			
I _I	V _{CC} = MAX,	V _I = 7 V	0.1			0.1			mA	
I _{IH}	V _{CC} = MAX,	V _I = 2.7 V	20			20			μA	
I _{IL}	V _{CC} = MAX,	V _I = 0.4 V	U/ \overline{D} , \overline{LOAD} , \overline{ENP} , CLK	-0.2			-0.2			mA
			All other inputs	-0.4			-0.4			
I _{OS} §	V _{CC} = MAX,	V _O = 0 V	\overline{RCO}	-20	-100	-20	-100	mA		
			Any Q	-30	-130	-30	-130			
I _{CC}	V _{CC} = MAX,	See Note 2	28	45	28	45	mA			

†For conditions shown as MIN or MAX, use the appropriate value specified under recommended operating conditions.

‡All typical values are at V_{CC} = 5 V, T_A = 25°C.

§Not more than one output should be shorted at a time, and duration of the short-circuit should not exceed one second.

NOTE 2: I_{CC} is measured after applying a momentary 4.5 V, then ground, to the clock input with all other inputs grounded and the outputs open.

switching characteristics, V_{CC} = 5 V, T_A = 25°C (see note 3)

PARAMETER¶	FROM (INPUT)	TO (OUTPUT)	TEST CONDITIONS	'LS169B			UNIT
				MIN	TYP	MAX	
f _{max}				20	35		MHz
t _{PLH}	CLK	\overline{RCO}	R _L = 2 kΩ, C _L = 15 pF	26 40			ns
t _{PHL}				17 25			
t _{PLH}	\overline{ENT}	\overline{RCO}		15 25			ns
t _{PHL}				11 20			
t _{PLH}	U/ \overline{D}	\overline{RCO}		23 35			ns
t _{PHL}				15 25			
t _{PLH}	CLK	Any Q		16 25			ns
t _{PHL}				17 25			
			R _L = 667 Ω, C _L = 45 pF	16 25			ns

¶ Propagation delay time from up/down to ripple carry must be measured with the counter at either a minimum or a maximum count. As the logic level of the up/down input is changed, the ripple carry output will follow. If the count is minimum (0), the ripple carry output transition will be in phase. If the count is maximum (15), the ripple carry output will be out of phase.

NOTE 3: See General Information Section for load circuits and voltage waveforms.

3
TTL DEVICES

TYPES SN54S168, SN54S169, SN74S168, SN74S169 SYNCHRONOUS 4-BIT UP/DOWN COUNTERS

schematics of inputs and outputs

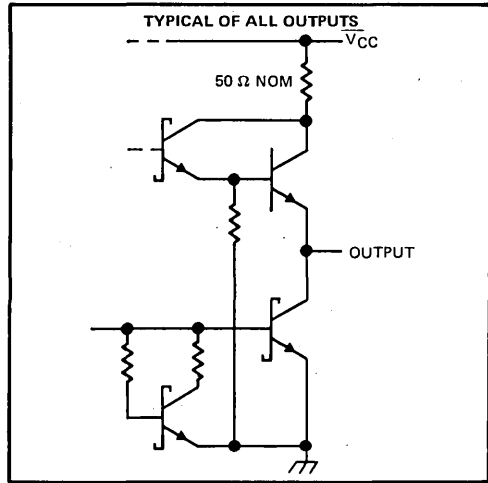
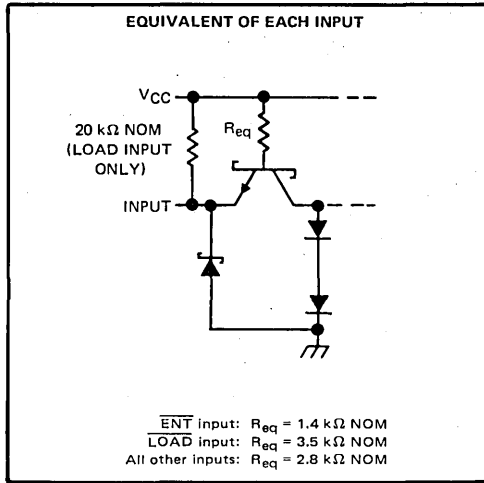

absolute maximum ratings over operating free-air temperature range (unless otherwise noted)

Supply voltage, V_{CC} (see Note 4)	7 V
Input voltage	5.5 V
Intermitter voltage (see Note 5)	5.5 V
Operating free-air temperature range: SN54S168, SN54S169 (see Note 6)	-55°C to 125°C
SN74S168, SN74S169	0°C to 70°C
Storage temperature range	-65°C to 150°C

recommended operating conditions

	SN54S168 SN54S169			SN74S168 SN74S169			UNIT
	MIN	NOM	MAX	MIN	NOM	MAX	
Supply voltage, V_{CC}	4.5	5	5.5	4.75	5	5.25	V
High-level output current, I_{OH}			-1			-1	mA
Low-level output current, I_{OL}			20			20	mA
Clock frequency, f_{clock}	0		40	0		40	MHz
Width of clock pulse, $t_w(\text{clock})$ (high or low) (see Figure 1)		10			10		ns
Setup time, t_{SU} (see Figure 1)	Data inputs A, B, C, D			4			ns
	ENP or ENT			14			
	Load			6			
	Up/Down			20			
Hold time, at any input with respect to clock, t_H (see Figure 1)		1			1		ns
Operating free-air temperature, T_A (see Note 6)		-55	125		0	70	°C

- NOTES: 4. Voltage values, except intermitter voltage, are with respect to network ground terminal.
 5. This is the voltage between two emitters of a multiple-emitter transistor. For these circuits, this rating applies between the count enable inputs ENP and ENT.
 6. An SN54S168 or SN54S169 in the W package operating at free-air temperatures above 91°C requires a heat sink that provides a thermal resistance from case to free-air, $R_{\theta CA}$, of not more than 26°C/W.

TYPES SN54S168, SN54S169, SN74S168, SN74S169 SYNCHRONOUS 4-BIT UP/DOWN COUNTERS

electrical characteristics over recommended operating free-air temperature range (unless otherwise noted)

PARAMETER	TEST CONDITIONS†	SN54S168 SN54S169			SN74S168 SN74S169			UNIT
		MIN	TYP‡	MAX	MIN	TYP‡	MAX	
V _{IH} High-level input voltage		2			2			V
V _{IL} Low-level input voltage		0.8			0.8			V
V _{IK} Input clamp voltage	V _{CC} = MIN, I _I = -18 mA	-1.2			-1.2			V
V _{OH} High-level output voltage	V _{CC} = MIN, V _{IH} = 2 V, V _{IL} = 0.8 V, I _{OH} = -1 mA	2.5	3.4		2.7	3.4	V	
V _{OL} Low-level output voltage	V _{CC} = MIN, V _{IH} = 2 V, V _{IL} = 0.8 V, I _{OL} = 20 mA	0.5			0.5			V
I _I Input current at maximum input voltage	V _{CC} = MAX, V _I = 5.5 V	1			1			mA
I _{IH} High-level input current	ENT	100			100			μA
	Load	-10			-10			
	Other inputs	-200			-200			
I _{IL} Low-level input current	ENT	50			50			mA
	Other inputs	-4			-4			
	Other inputs	-2			-2			
I _{OS} Short-circuit output current§	V _{CC} = MAX	-40	-100		-40	-100	mA	
I _{CC} Supply current	V _{CC} = MAX, See Note 2	100	160		100	160	mA	

† For conditions shown as MIN or MAX, use the appropriate value specified under recommended operating conditions.

‡ All typical values are at V_{CC} = 5 V, T_A = 25°C.

§ Not more than one output should be shorted at a time, and duration of the short-circuit should not exceed one second.

NOTE 2: I_{CC} is measured after applying a momentary 4.5 V, then ground, to the clock input with all other inputs grounded and the outputs open.

switching characteristics, V_{CC} = 5 V, T_A = 25°C

PARAMETER†	FROM (INPUT)	TO (OUTPUT)	TEST CONDITIONS	UP/DOWN = HIGH			UP/DOWN = LOW			UNIT
				MIN	TYP	MAX	MIN	TYP	MAX	
f _{max}			C _L = 15 pF, R _L = 280 Ω, See Figures 2 and 3 and Note 3	40	70		40	55		MHz
t _{PLH}	CLK	RCO		14	21		14	21		ns
t _{PHL}		RCO		20	28		20	28		ns
t _{PLH}	CLK	Any Q		8	15		8	15		ns
t _{PHL}		Any Q		11	15		11	15		ns
t _{PLH}	ENT	RCO		7.5	11		6	12		ns
t _{PHL}		RCO		15	22		15	25		ns
t _{PLH} °	U/D	RCO		9	15		8	15		ns
t _{PHL} °		RCO		10	15		16	22		ns

† f_{max} = maximum clock frequency

t_{PLH} = propagation delay time, low-to-high-level output

t_{PHL} = propagation delay time, high-to-low-level output

Propagation delay time from up/down to ripple carry must be measured with the counter at either a minimum or a maximum count. As the logic level of the up/down input is changed, the ripple carry output will follow. If the count is minimum (0), the ripple carry output transition will be in phase. If the count is maximum (9 for 'S168 or 15 for 'S169), the ripple carry output will be out of phase.

NOTE 3: See General Information Section for load circuits and voltage waveforms.



TTL DEVICES

**TYPES SN54LS169B, SN54S168, SN54S169,
SN74LS169B, SN74S168, SN74S169
SYNCHRONOUS 4-BIT UP/DOWN COUNTERS**

PARAMETER MEASUREMENT INFORMATION

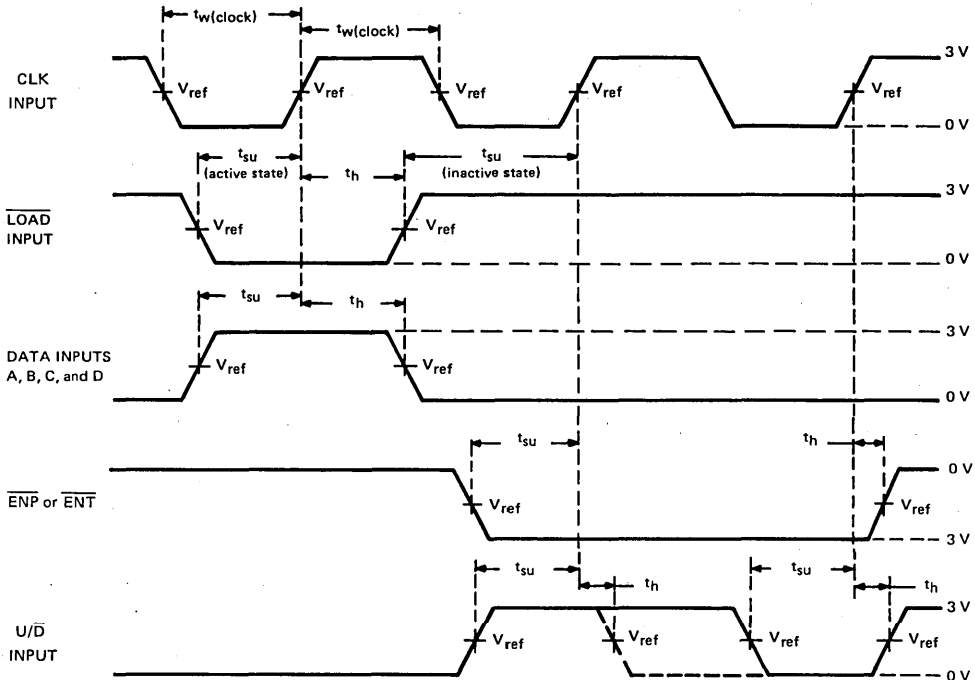

VOLTAGE WAVEFORMS

- NOTES: A. The input pulses are supplied by a generator having the following characteristics: PRR \leq 1 MHz, duty cycle \leq 50%, $Z_{\text{out}} \approx 50 \Omega$; for 'LS169B, $t_r \leq 15$ ns, $t_f \leq 6$ ns, and for 'S168 and 'S169, $t_r \leq 2.5$ ns, $t_f \leq 2.5$ ns.
B. For 'LS169B, $V_{\text{ref}} = 1.3$ V; for 'S168 and 'S169, $V_{\text{ref}} = 1.5$ V.

FIGURE 1—PULSE WIDTHS, SETUP TIMES, HOLD TIMES

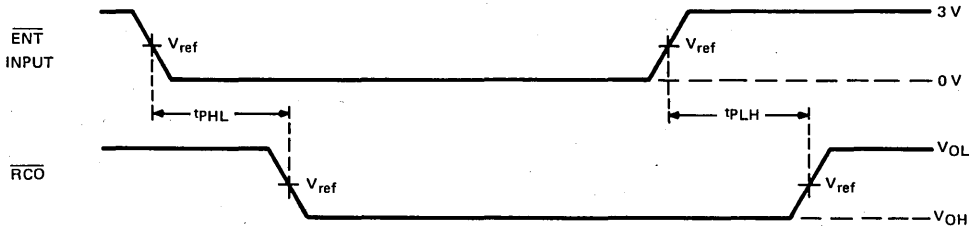

VOLTAGE WAVEFORMS

- NOTES: A. The input pulses are supplied by a generator having the following characteristics: PRR \leq 1 MHz, duty cycle \leq 50%, $Z_{\text{out}} \approx 50 \Omega$; for 'LS169B, $t_r \leq 15$ ns, $t_f \leq 6$ ns; and for 'S168 and 'S169, $t_r \leq 2.5$ ns, $t_f \leq 2.5$ ns.
B. t_{PLH} and t_{PHL} from enable T input to ripple carry output assume that the counter is at the maximum count (Q_A and Q_D high for 'S168, all Q outputs high for 'LS169B and 'S169).
C. For 'LS169B, $V_{\text{ref}} = 1.3$ V; for 'S168 and 'S169, $V_{\text{ref}} = 1.5$ V.
D. Propagation delay time from up/down to ripple carry must be measured with the counter at either a minimum or a maximum count. As the logic level of the up/down input is changed, the ripple carry output will follow. If the count is minimum (0) the ripple carry output transition will be in phase. If the count is maximum (9 for 'S168 or 15 or 'LS169B and 'S169), the ripple carry output will be out of phase.

FIGURE 2—PROPAGATION DELAY TIMES TO CARRY OUTPUT

TYPES SN54LS169B, SN54S168, SN54S169,
SN74LS169B, SN74S168, SN74S169
SYNCHRONOUS 4-BIT UP/DOWN COUNTERS

PARAMETER MEASUREMENT INFORMATION

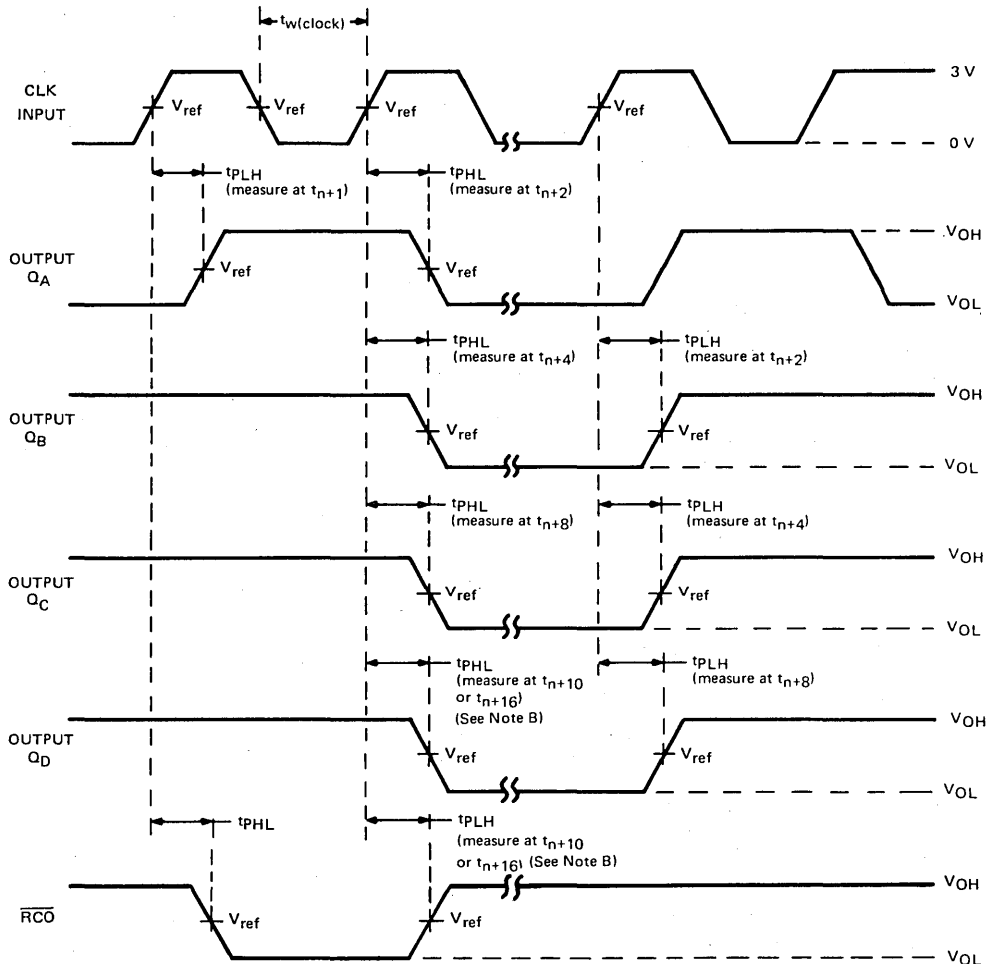

UP-COUNT VOLTAGE WAVEFORMS

- NOTES: A. The input pulses are supplied by a generator having the following characteristics: PRR \leq 1 MHz, duty cycle \leq 50%, $Z_{out} \approx 50 \Omega$; for 'LS169B, $t_r \leq 15$ ns, $t_f \leq 6$ ns; and for 'S168 and 'S169, $t_r \leq 2.5$ ns, $t_f \leq 2.5$ ns. Vary PRR to measure f_{max} .
- B. Outputs Q_D and carry are tested at t_{n+10} for the 'S168 and at t_{n+16} for the 'LS169B and 'S169, where t_n is the bit-time when all outputs are low.
- C. For 'LS169B, $V_{ref} = 1.3$ V; for 'S168 and 'S169, $V_{ref} = 1.5$ V.

FIGURE 3—PROPAGATION DELAY TIMES FROM CLOCK

TYPES SN54170, SN54LS170, SN74170, SN74LS170 4-BY-4 REGISTER FILES WITH OPEN-COLLECTOR OUTPUTS

MARCH 1974—REVISED DECEMBER 1983

- Separate Read/Write Addressing Permits Simultaneous Reading and Writing
- Fast Access Times . . . Typically 20 ns
- Organized as 4 Words of 4 Bits
- Expandable to 1024 Words of n-Bits
- For Use as:
 - Scratch-Pad Memory
 - Buffer Storage between Processors
 - Bit Storage in Fast Multiplication Designs
- Open-Collector Outputs with Low Maximum Off-State Current:
 - '170 . . . 30 μ A
 - 'LS170 . . . 20 μ A
- SN54LS670 and SN74LS670 Are Similar But Have 3-State Outputs

description

The '170 and 'LS170 MSI 16-bit TTL register files incorporate the equivalent of 98 gates. The register file is organized as 4 words of 4 bits each and separate on-chip decoding is provided for addressing the four word locations to either write-in or retrieve data. This permits simultaneous writing into one location and reading from another word location.

Four data inputs are available which are used to supply the 4-bit word to be stored. Location of the word is determined by the write-address inputs A and B in conjunction with a write-enable signal. Data applied at the inputs should be in its true form. That is, if a high-level signal is desired from the output, a high level is applied at the data input for that particular bit location. The latch inputs are arranged so that new data will be accepted only if both internal address gate inputs are high. When this condition exists, data at the D input is transferred to the latch output. When the write-enable input, \overline{G}_W , is high, the data inputs are inhibited and their levels can cause no change in the information stored in the internal latches. When the read-enable input, \overline{G}_R , is high, the data outputs are inhibited and remain high.

The individual address lines permit direct acquisition of data stored in any four of the latches. Four individual decoding gates are used to complete the address for reading a word. When the read address is made in conjunction with the read-enable signal, the word appears at the four outputs.

This arrangement—data-entry addressing separate from data-read addressing and individual sense line—eliminates recovery times, permits simultaneous reading and writing, and is limited in speed only by the write time (30 nanoseconds typical) and the read time (25 nanoseconds typical). The register file has a nondestructive readout in that data is not lost when addressed.

All '170 inputs and all inputs except the read enable and write enable of the 'LS170 are buffered to lower the drive requirements to one Series 54/74 or Series 54LS/74LS standard load, respectively. Input-clamping diodes minimize switching transients to simplify system design. High-speed, double-ended AND-OR-INVERT gates are employed for the read-address function and drive high-sink-current, open-collector outputs. Up to 256 of these outputs may be wire-AND connected for increasing the capacity up to 1024 words. Any number of these registers may be paralleled to provide n-bit word length.

The SN54170 and SN54LS170 are characterized for operation over the full military temperature range of -55°C to 125°C ; the SN74170 and SN74LS170 are characterized for operation from 0°C to 70°C .

SN54170, SN54LS170 . . . J OR W PACKAGE
SN74170 . . . J OR N PACKAGE
SN74LS170 . . . D, J OR N PACKAGE

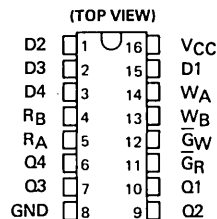

SN54LS170 . . . FK PACKAGE
SN74LS170 . . . FN PACKAGE

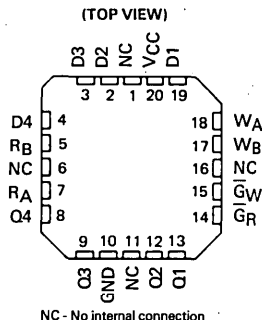

PRODUCTION DATA
This document contains information current as of publication date. Products conform to specifications per the terms of Texas Instruments standard warranty. Production processing does not necessarily include testing of all parameters.

**TEXAS
INSTRUMENTS**

POST OFFICE BOX 225012 • DALLAS, TEXAS 75265

3-665

3

TTL DEVICES

TYPES SN54170, SN74170
4-BY-4 REGISTER FILES WITH OPEN-COLLECTOR OUTPUTS

logic diagram

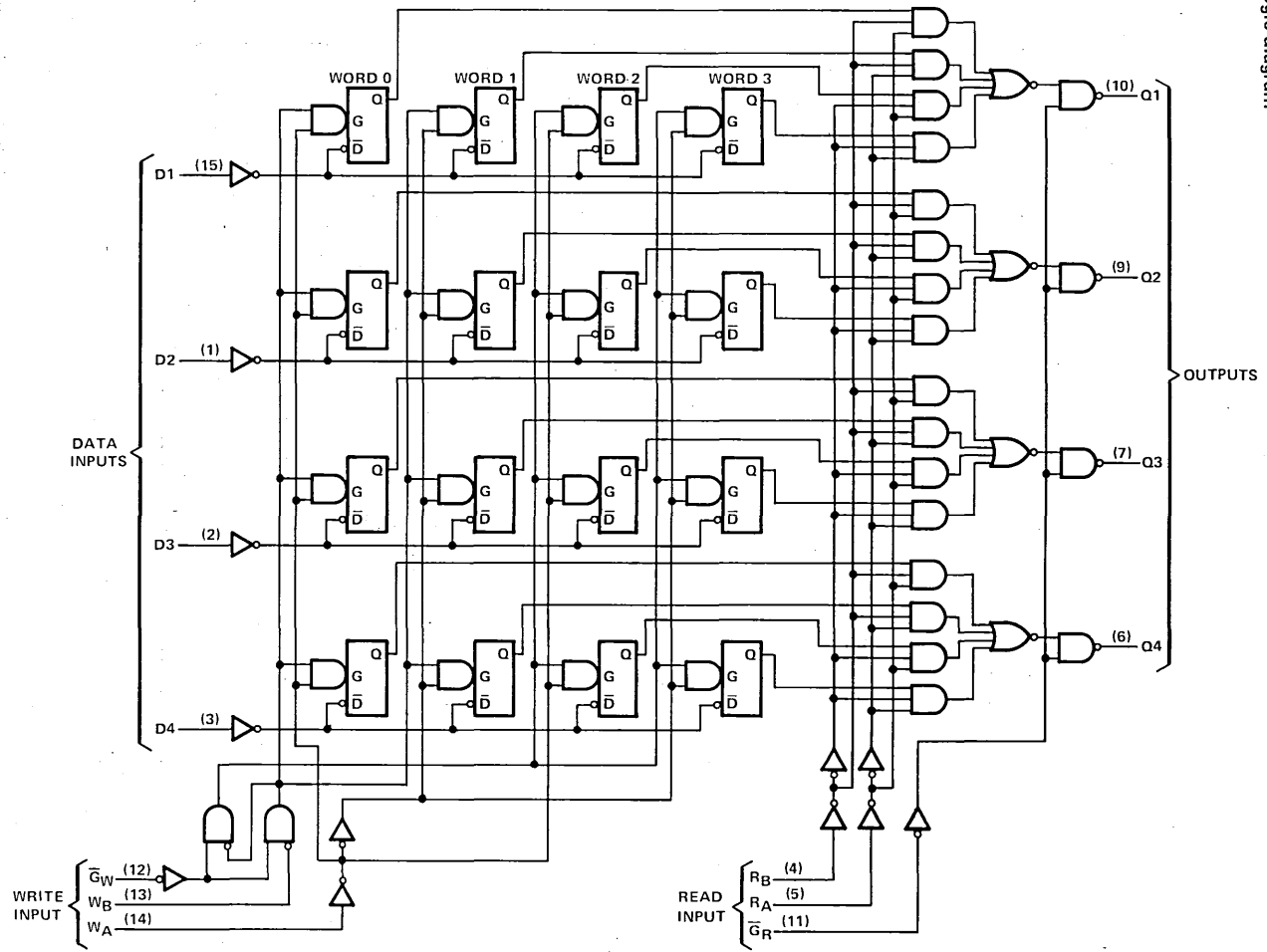

Pin numbers shown on logic notation are for D, J or N packages.

TYPES SN54LS170, SN74LS170
4-BY-4 REGISTER FILES WITH OPEN-COLLECTOR OUTPUTS

logic diagram

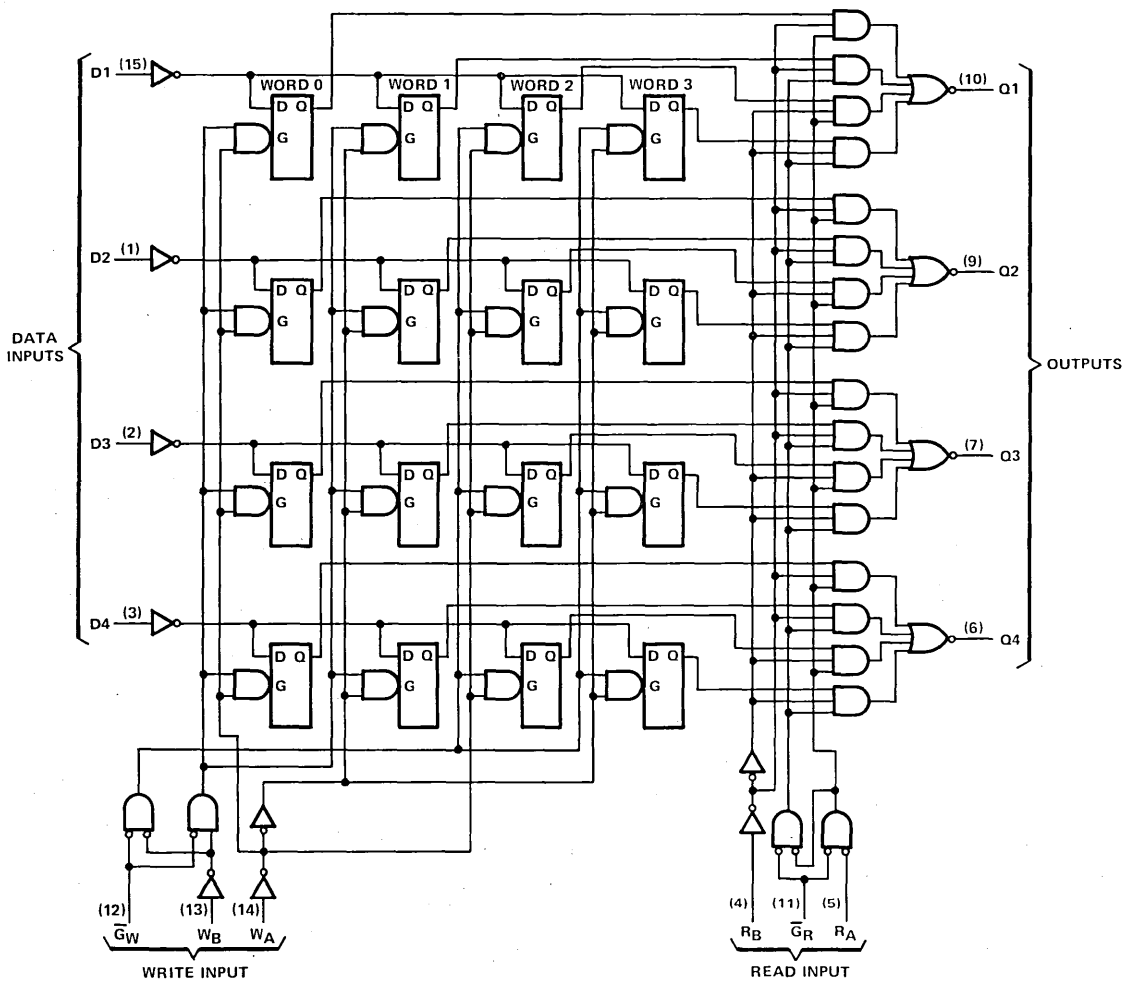

Pin numbers shown on logic notation are for D, J or N packages.

TTL DEVICES



TEXAS INSTRUMENTS
POST OFFICE BOX 225012 • DALLAS, TEXAS 75265

3-667

**TYPES SN54170, SN54LS170, SN74170, SN74LS170
4-BY-4 REGISTER FILES WITH OPEN-COLLECTOR OUTPUTS**

logic

WRITE FUNCTION TABLE (SEE NOTES A, B, AND C)

WRITE INPUTS			WORD			
W _B	W _A	\overline{G}_W	0	1	2	3
L	L	L	Q = D	Q ₀	Q ₀	Q ₀
L	H	L	Q ₀	Q = D	Q ₀	Q ₀
H	L	L	Q ₀	Q ₀	Q = D	Q ₀
H	H	L	Q ₀	Q ₀	Q ₀	Q = D
X	X	H	Q ₀	Q ₀	Q ₀	Q ₀

READ FUNCTION TABLE (SEE NOTES A AND D)

READ INPUTS			OUTPUTS			
R _B	R _A	\overline{G}_R	Q1	Q2	Q3	Q4
L	L	L	W0B1	W0B2	W0B3	W0B4
L	H	L	W1B1	W1B2	W1B3	W1B4
H	L	L	W2B1	W2B2	W2B3	W2B4
H	H	L	W3B1	W3B2	W3B3	W3B4
X	X	H	H	H	H	H

- NOTES: A. H = high level, L = low level, X = irrelevant.
 B. (Q = D) = The four selected internal flip-flop outputs will assume the states applied to the four external data inputs.
 C. Q₀ = the level of Q before the indicated input conditions were established.
 D. W0B1 = The first bit of word 0, etc.

absolute maximum ratings over operating free-air temperature range (unless otherwise noted)

Supply voltage, V _{CC} (see Note 1)	7 V
Input voltage: '170	5.5 V
'LS170	7 V
Off-state output voltage: '170	5.5 V
'LS170	7 V
Operating free-air temperature range: SN54170, SN54LS170 (see Note 2)	-55°C to 125°C
SN74170, SN74LS170	0°C to 70°C
Storage temperature range	-65°C to 150°C

- NOTES: 1. Voltage values are with respect to network ground terminal.
 2. An SN54170 in the W package operating at free-air temperatures above 105°C requires a heat sink that provides a thermal resistance from case to free-air, R_{θCA}, of not more than 38°C/W

3

TTL DEVICES

TYPES SN54170, SN74170

4-BY-4 REGISTER FILES WITH OPEN-COLLECTOR OUTPUTS

recommended operating conditions

		SN54170			SN74170			UNIT
		MIN	NOM	MAX	MIN	NOM	MAX	
Supply voltage, V_{CC}		4.5	5	5.5	4.75	5	5.25	V
High-level output voltage, V_{OH}					5.5			V
Low-level output current, I_{OL}					16			mA
Width of write-enable or read-enable pulse, t_w		25			25			ns
Setup times, high- or low-level data (see Figure 2)	Data input with respect to write enable, $t_{su}(D)$	10			10			ns
	Write select with respect to write enable, $t_{su}(W)$	15			15			ns
Hold times, high- or low-level data (see Note 3 and Figure 2)	Data input with respect to write enable, $t_h(D)$	15			15			ns
	Write select with respect to write enable, $t_h(W)$	5			5			ns
Latch time for new data, t_{latch} (see Note 4)		25			25			ns
Operating free-air temperature range, T_A (see Note 2)		-55			125			$^{\circ}C$

- NOTES: 2. An SN54170 in the W package operating at free-air temperatures above $105^{\circ}C$ requires a heat sink that provides a thermal resistance from case to free-air, $R_{\theta CA}$, of not more than $38^{\circ}C/W$.
3. Write select setup time will protect the data written into the previous address. If protection of data in the previous address is not required, $t_{su}(W)$ can be ignored as any address selection sustained for the final 30 ns of the write-enable pulse and during $t_h(W)$ will result in data being written into that location. Depending on the duration of the input conditions, one or a number of previous addresses may have been written into.
4. Latch time is the time allowed for the internal output of the latch to assume the state of new data. See Figure 2. This is important only when attempting to read from a location immediately after that location has received new data.

electrical characteristics over recommended operating free-air temperature range (unless otherwise noted)

PARAMETER	TEST CONDITIONS†	MIN	TYP‡	MAX	UNIT	
		2				
V_{IH} High-level input voltage		2			V	
V_{IL} Low-level input voltage		0.8			V	
V_{IK} Input clamp voltage	$V_{CC} = \text{MIN}, I_I = -12 \text{ mA}$	-1.5			V	
I_{OH} High-level output current	$V_{CC} = \text{MIN}, V_{OH} = 5.5 \text{ V}, V_{IH} = 2 \text{ V}, V_{IL} = 0.8 \text{ V}$	30			μA	
V_{OL} Low-level output voltage	$V_{CC} = \text{MIN}, V_{IH} = 2 \text{ V}, V_{IL} = 0.8 \text{ V}, I_{OL} = 16 \text{ mA}$	0.2	0.4		V	
I_I Input current at maximum input voltage	$V_{CC} = \text{MAX}, V_I = 5.5 \text{ V}$	1			mA	
I_{IH} High-level input current	$V_{CC} = \text{MAX}, V_I = 2.4 \text{ V}$	40			μA	
I_{IL} Low-level input current	$V_{CC} = \text{MAX}, V_I = 0.4 \text{ V}$	-1.6			mA	
I_{CC} Supply current	$V_{CC} = \text{MAX}$	127§			140	mA
	See Note 5	SN54170	127§		150	

†For conditions shown as MIN or MAX, use the appropriate value specified under recommended operating conditions.

‡All typical values are at $V_{CC} = 5 \text{ V}, T_A = 25^{\circ}C$.

§Typical supply current shown is an average for 50% duty cycle.

NOTE 5: Maximum I_{CC} is guaranteed for the following worst-case conditions: 4.5 V is applied to all data inputs and both enable inputs, all address inputs are grounded, and all outputs are open.

3

TTL DEVICES

TYPES SN54170, SN74170 4-BY-4 REGISTER FILES WITH OPEN-COLLECTOR OUTPUTS

switching characteristics, $V_{CC} = 5\text{ V}$, $T_A = 25^\circ\text{C}$

PARAMETER ¹	FROM (INPUT)	TO (OUTPUT)	TEST CONDITIONS	MIN	TYP	MAX	UNIT
t_{PLH}	Read enable	Any Q	$C_L = 15\text{ pF}$, $R_L = 400\ \Omega$, See Figures 1 and 2	10	15	ns	
t_{PHL}				20	30		
t_{PLH}	Read Select	Any Q		23	35	ns	
t_{PHL}				30	40		
t_{PLH}	Write enable	Any Q		25	40	ns	
t_{PHL}				34	45		
t_{PLH}	Data	Any Q	20	30	ns		
t_{PHL}			30	45			

¹ t_{PLH} = propagation delay time, low-to-high-level output
 t_{PHL} = propagation delay time, high-to-low-level output

schematics of inputs and outputs

'170

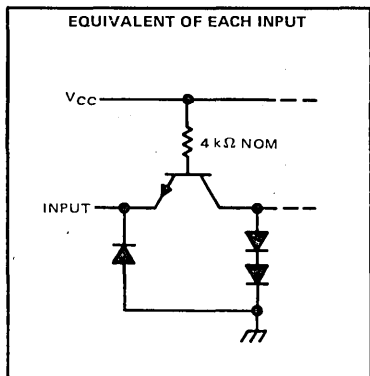

'170

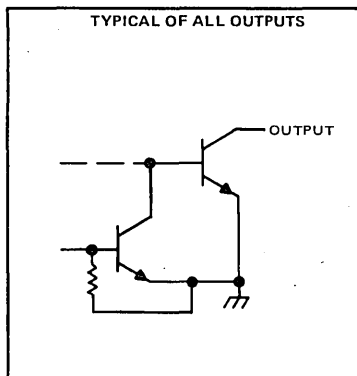

3

TTL DEVICES

TYPES SN54LS170, SN74LS170 4-BY-4 REGISTER FILES WITH OPEN-COLLECTOR OUTPUTS

recommended operating conditions

		SN54LS170			SN74LS170			UNIT
		MIN	NOM	MAX	MIN	NOM	MAX	
Supply voltage, V_{CC}		4.5	5	5.5	4.75	5	5.25	V
High-level output voltage, V_{OH}					5.5			V
Low-level output current, I_{OL}					4			8 mA
Width of write-enable or read-enable pulse, t_w		25			25			ns
Setup times, high- or low-level data (see Figure 2)		Data input with respect to write enable, $t_{su}(D)$		10			10	ns
		Write select with respect to write enable, $t_{su}(W)$		15			15	ns
Hold times, high- or low-level data (see Note 3 and Figure 2)		Data input with respect to write enable, $t_h(D)$		15			15	ns
		Write select with respect to write enable, $t_h(W)$		5			5	ns
Latch time for new data, t_{latch} (see Note 4)		25			25			ns
Operating free-air temperature range, T_A		-55			125			0 70 °C

NOTES: 3. Write-select setup time will protect the data written into the previous address. If protection of data in the previous address is not required, $t_{su}(W)$ can be ignored as any address selection sustained for the final 30 ns of the write-enable pulse and during $t_h(W)$ will result in data being written into that location. Depending on the duration of the input conditions, one or a number of previous addresses may have been written into.

4. Latch time is the time allowed for the internal output of the latch to assume the state of new data. See Figure 2. This is important only when attempting to read from a location immediately after that location has received new data.

electrical characteristics over recommended operating free-air temperature range (unless otherwise noted)

PARAMETER		TEST CONDITIONS†		SN54LS170			SN74LS170			UNIT
				MIN	TYP‡	MAX	MIN	TYP‡	MAX	
V_{IH}	High-level input voltage			2			2			V
V_{IL}	Low-level input voltage			0.7			0.8			V
V_{IK}	Input clamp voltage	$V_{CC} = \text{MIN}, I_I = -18 \text{ mA}$		-1.5			-1.5			V
I_{OH}	High-level output current	$V_{CC} = \text{MIN}, V_{OH} = 5.5 \text{ V}, V_{IL} = V_{IL \text{ max}}, V_{IH} = 2 \text{ V}$		100			100			μA
V_{OL}	Low-level output voltage	$V_{CC} = \text{MIN}, V_{IH} = 2 \text{ V}, V_{IL} = V_{IL \text{ max}}$		$I_{OL} = 4 \text{ mA}$	0.25	0.4	0.25	0.4	V	
			$I_{OL} = 8 \text{ mA}$			0.35	0.5			
I_I	Input current at maximum input voltage	Any D, R, or W		$V_{CC} = \text{MAX}, V_I = 7 \text{ V}$		0.1		0.1		mA
		\bar{G}_R or \bar{G}_W				0.2		0.2		
I_{IH}	High-level input current	Any D, R, or W		$V_{CC} = \text{MAX}, V_I = 2.7 \text{ V}$		20		20		μA
		\bar{G}_R or \bar{G}_W				40		40		
I_{IL}	Low-level input current	Any D, R, or W		$V_{CC} = \text{MAX}, V_I = 0.4 \text{ V}$		-0.4		-0.4		mA
		\bar{G}_R or \bar{G}_W				-0.8		-0.8		
I_{CC}	Supply current	$V_{CC} = \text{MAX},$ See Note 5		25 40		25 40		mA		

†For conditions shown as MIN or MAX, use the appropriate value specified under recommended operating conditions.

‡All typical values are at $V_{CC} = 5 \text{ V}, T_A = 25^\circ\text{C}$.

NOTE 5: I_{CC} is measured under the following worst-case conditions: 4.5 V is applied to all data inputs and both enable inputs, all address inputs are ground, and all outputs are open.

3
TTL DEVICES



TYPES SN54LS170, SN74LS170

4-BY-4 REGISTER FILES WITH OPEN-COLLECTOR OUTPUTS

switching characteristics, $V_{CC} = 5\text{ V}$, $T_A = 25^\circ\text{C}$

PARAMETER [†]	FROM (INPUT)	TO (OUTPUT)	TEST CONDITIONS	MIN	TYP	MAX	UNIT
t_{PLH}	Read enable	Any Q	$C_L = 15\text{ pF}$, $R_L = 2\text{ k}\Omega$, See Figures 1 and 2	20	30	ns	
t_{PHL}				20	30		
t_{PLH}	Read select	Any Q		25	40	ns	
t_{PHL}				24	40		
t_{PLH}	Write enable	Any Q	$C_L = 15\text{ pF}$, $R_L = 2\text{ k}\Omega$, See Figures 1 and 3	30	45	ns	
t_{PHL}				26	40		
t_{PLH}	Data	Any Q		30	45	ns	
t_{PHL}				22	35		

[†] t_{PLH} = propagation delay time, low-to-high-level output
 t_{PHL} = propagation delay time, high-to-low-level output

schematics of inputs and outputs

'LS170

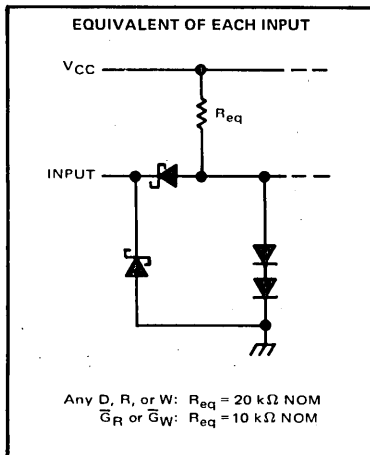

'LS170

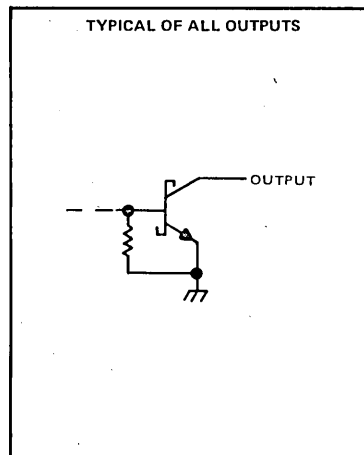

3

TTL DEVICES

TYPES SN54170, SN54LS170, SN74170, SN74LS170 4-BY-4 REGISTER FILES WITH OPEN-COLLECTOR OUTPUTS

PARAMETER MEASUREMENT INFORMATION

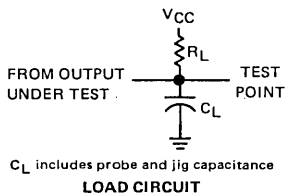
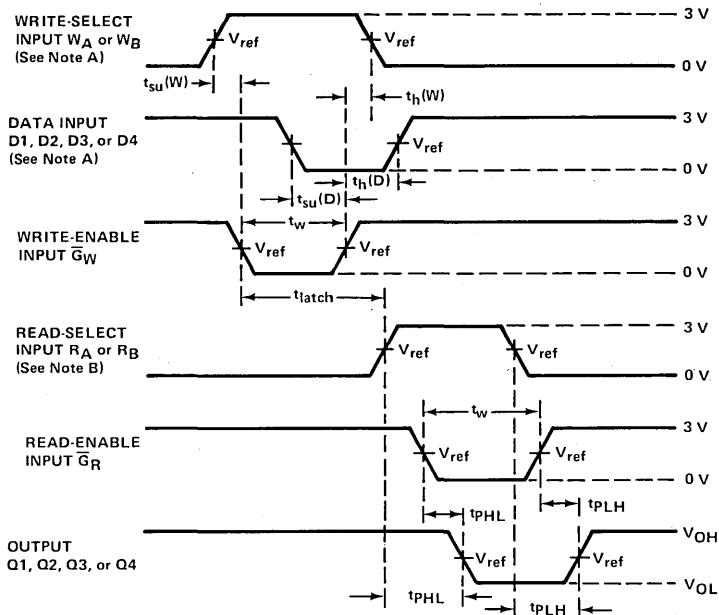

FIGURE 1



VOLTAGE WAVEFORMS

FIGURE 2

- NOTES: A. High-level input pulses at the select and data inputs are illustrated in Figure 2; however, times associated with low-level pulses are measured from the same reference points.
- B. When measuring delay times from a read-select input, the read-enable input is low. When measuring delay times from the read-enable input, both read-select inputs have been established at steady states.
- C. In Figure 3, each select address is tested. Prior to the start of each of the above tests, both write and read address inputs are stabilized with $W_A = R_A$ and $W_B = R_B$. During the test \bar{G}_R is low.
- D. Input waveforms are supplied by generators having the following characteristics: $PRR \leq 1$ MHz, $Z_{out} \approx 50 \Omega$, duty cycle $< 50\%$, $t_r \leq 10$ ns and $t_f \leq 10$ ns for '170, and $t_r \leq 15$ ns and $t_f \leq 6$ ns for 'LS170.
- E. For '170, $V_{ref} = 1.5$ V; for 'LS170, $V_{ref} = 1.3$ V.

3
 TTL DEVICES

TYPES SN54170, SN54LS170, SN74170, SN74LS170
 4-BY-4 REGISTER FILES WITH OPEN-COLLECTOR OUTPUTS

PARAMETER MEASUREMENT INFORMATION

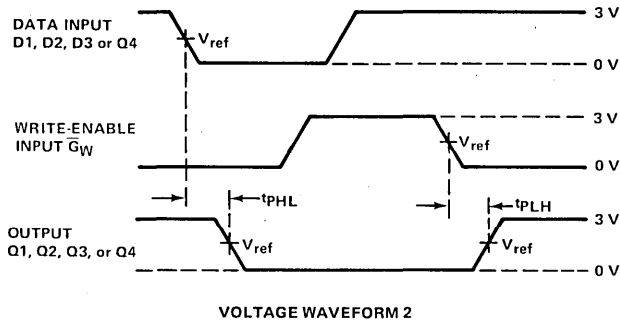
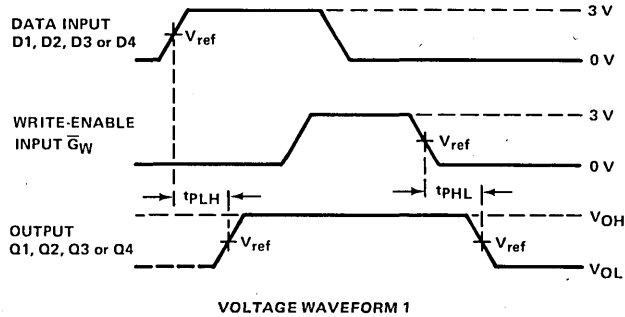

FIGURE 3

- NOTES: A. High-level input pulses at the select and data inputs are illustrated in Figure 2; however, times associated with low-level pulses are measured from the same reference points.
- B. When measuring delay times from a read-select input, the read-enable input is low. When measuring delay times from the read-enable input, both read-select inputs have been established at steady states.
- C. In Figure 3, each select address is tested. Prior to the start of each of the above tests, both write and read address inputs are stabilized with $W_A = R_A$ and $W_B = R_B$. During the test G_R is low.
- D. Input waveforms are supplied by generators having the following characteristics: $PRR \leq 1$ MHz, $Z_{out} \approx 50 \Omega$, duty cycle $\leq 50\%$, $t_r \leq 10$ ns and $t_f \leq 10$ ns for '170, and $t_r \leq 15$ ns and $t_f \leq 6$ ns for 'LS170.
- E. For '170, $V_{ref} = 1.5$ V; for 'LS170, $V_{ref} = 1.3$ V.

TYPES SN54LS171, SN74LS171 QUADRUPLE D-TYPE FLIP-FLOPS WITH CLEAR

REVISED DECEMBER 1983

- Contains Four Flip-Flops with Double Rail Outputs
- Buffered Clock and Clear Inputs
- Individual Data Inputs to Each Flip-Flop

description

These monolithic, positive-edge triggered flip-flops utilize the latest low-power Schottky circuitry to implement D-type flip-flop logic. They have a direct clear input and complementary outputs from each flip-flop.

Information at the D inputs meeting the setup time requirements is transferred to the Q outputs on the positive-going edge of the clock pulse. Clock triggering occurs at a particular voltage level and is not directly related to the transition time of the positive going pulse. When the clock input is at either the high or low level, the D input signal has no effect at the output.

logic diagram

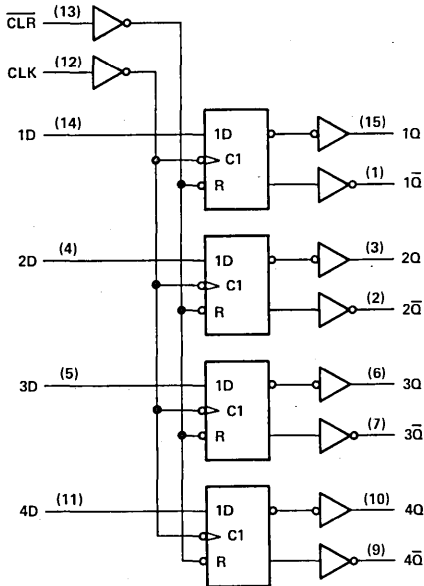

Pin numbers shown on logic notation are for D, J or N packages.

SN54LS171 ... J OR W PACKAGE
SN74LS171 ... D, J OR N PACKAGE
(TOP VIEW)

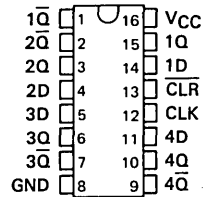

SN54LS171 ... FK PACKAGE
SN74LS171 ... FN PACKAGE
(TOP VIEW)

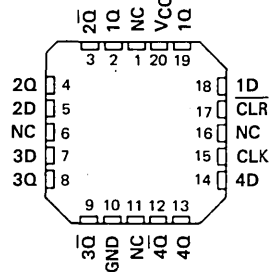

NC-No internal connection

FUNCTION TABLE
(EACH FLIP-FLOP)

INPUTS			OUTPUTS	
CLR	CLK	D	Q	\bar{Q}
L	X	X	L	H
H	↑	H	H	L
H	↑	L	L	H
H	L	X	Q_0	\bar{Q}_0

PRODUCTION DATA
This document contains information current as of publication date. Products conform to specifications per the terms of Texas Instruments standard warranty. Production processing does not necessarily include testing of all parameters.

TEXAS INSTRUMENTS
POST OFFICE BOX 225012 • DALLAS, TEXAS 75265

3-675

TTL DEVICES

TYPES SN54LS171, SN74LS171 QUADRUPLE D-TYPE FLIP-FLOPS WITH CLEAR

schematics of inputs and outputs

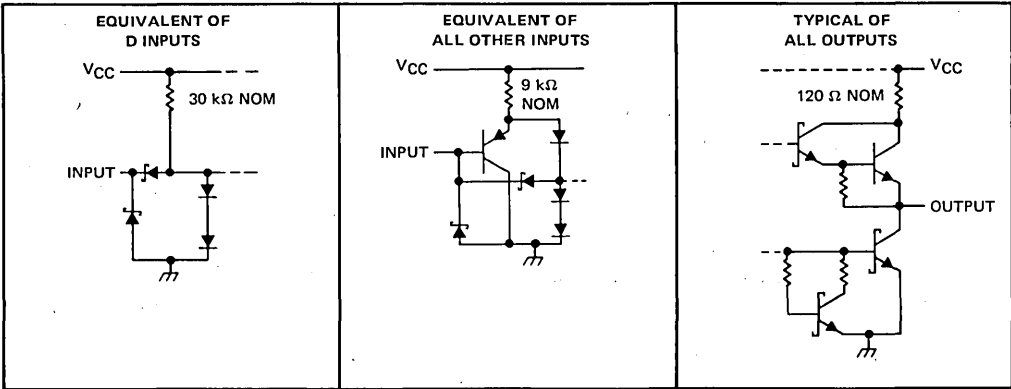

absolute maximum ratings over operating free-air temperature range (unless otherwise noted)

Supply voltage, V_{CC} (See Note 1)	7 V
Input voltage	7 V
Operating free-air temperature range: SN54LS171 Circuits	-55°C to 125°C
SN74LS171 Circuits	0°C to 70°C
Storage temperature range	-65°C to 150°C

NOTE 1: Voltage values are with respect to network ground terminal.

recommended operating conditions

	SN54LS171			SN74LS171			UNIT
	MIN	NOM	MAX	MIN	NOM	MAX	
V_{CC} Supply voltage	4.5	5	5.5	4.75	5	5.25	V
V_{IH} High-level input voltage	2			2			V
V_{IL} Low-level input voltage			0.7			0.8	V
I_{OH} High-level output current			-0.4			-0.4	mA
I_{OL} Low-level output current			4			8	mA
f_{clock} Clock frequency	0		20	0		20	MHz
t_w Width of clock or clear pulse		20			20		ns
t_{su} Setup time							ns
	Data input		20		20		
	Clear inactive-state		25		25		
t_h Data hold time		5			5		ns
T_A Operating free-air temperature		-55	125		0	70	°C

3 TTL DEVICES

TYPES SN54LS171, SN74LS171 QUADRUPLE D-TYPE FLIP-FLOPS WITH CLEAR

electrical characteristics over recommended operating free-air temperature range (unless otherwise noted)

PARAMETER	TEST CONDITIONS†	SN54LS171		SN74LS171		UNIT
		MIN	TYP‡	MAX	MIN	
V _{IK}	Input clamp voltage V _{CC} = MIN, I _I = -18 mA	-1.5		-1.5		V
V _{OH}	High-level output voltage V _{CC} = MIN, V _{IH} = 2 V, V _{IL} = MAX, I _{OH} = -1 mA	2.5	3.4	2.7	3.4	V
V _{OL}	Low-level output voltage V _{CC} = MIN, V _{IH} = 2 V, V _{IL} = MAX, I _{OL} = 4 mA	0.25	0.4	0.25	0.4	V
				I _{OL} = 8 mA		0.35
I _I	Input current at maximum input voltage V _{CC} = MAX, V _I = 7 V	0.1		0.1		mA
I _{IH}	High-level input current V _{CC} = MAX, V _I = 2.7 V	20		20		μA
I _{IL}	Low-level input current D inputs All others	-0.4		-0.4		mA
		-0.2		-0.2		mA
I _{OS} §	Short-circuit output current V _{CC} = MAX, V _O = 0 V	-20	-100	-20	-100	mA
I _{CC}	Supply current V _{CC} = MAX, See Note 1	14	25	14	25	mA

† For conditions shown as MIN or MAX, use the appropriate value specified under recommended operating conditions.

‡ All typical values are at V_{CC} = 5 V, T_A = 25°C.

§ Not more than one output should be shorted at a time and the duration of the short-circuit should not exceed one second.

NOTE 1: I_{CC} is measured with all inputs grounded and all outputs open.

switching characteristics, V_{CC} = 5 V, T_A = 25°C (see note 2)

PARAMETER	FROM (INPUT)	TO (OUTPUT)	TEST CONDITIONS	'LS171			UNIT
				MIN	TYP	MAX	
f _{max}			R _L = 2 kΩ, C _L = 15 pF	20	30		MHz
t _{PLH}	CLK	Q, \bar{Q}		15	25		ns
t _{PHL}				18	30		ns
t _{PLH}	CLR	Q		18	30		ns
t _{PHL}				24	40		ns

NOTE 2: See General Information Section for load circuits and voltage waveforms.



TTL DEVICES

3

TTL DEVICES

TYPE SN74172 16-BIT MULTIPLE-PORT REGISTER FILE WITH 3-STATE OUTPUTS

MAY 1972—REVISED APRIL 1985

- Independent Read/Write Addressing Permits Simultaneous Reading and Writing
- Organized as Eight Words of Two Bits Each
- Fast Access Times:
 - From Read Enable . . . 15 ns Typical
 - From Read Select . . . 33 ns Typical
- 3-State Outputs Simplify Use in Bus-Organized Systems
- Applications:
 - Stacked Data Registers
 - Scratch-Pad Memory
 - Buffer Storage Between Processors
 - Fast Multiplication Schemes

SN74172 . . . J OR N PACKAGE
(TOP VIEW)

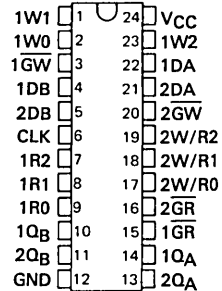

schematics of inputs and outputs

description

The SN74172, containing the equivalent of 201 gates on a monolithic chip, is a high-performance 16-bit register file organized as eight words of two bits each.

Multiple address decoding circuitry is used so that the read and write operation can be performed independently on two word locations. This provides a true simultaneous read/write capability. Basically, the file consists of two distinct sections (see Figure 1).

Section 1 permits the writing of data into any two-bit word location while reading two bits of data from another location simultaneously. To provide this flexibility, independent decoding is incorporated.

Section 2 of the register file is similar to section 1 with the exception that common read/write address circuitry is employed. This means that section 2 can be utilized in one of three modes:

- 1) Writing new data into two bits
- 2) Reading from two bits
- 3) Writing into and simultaneously reading from the same two bits.

Regardless of the mode, the operation of section 2 is entirely independent of section 1.

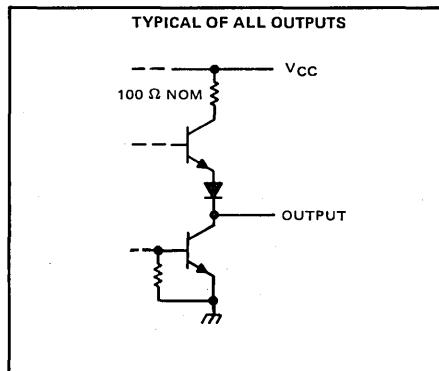
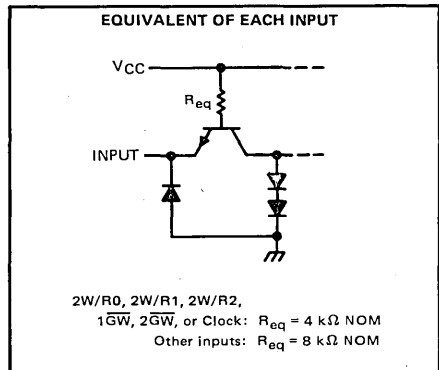

PRODUCTION DATA
This document contains information current as of publication date. Products conform to specifications per the terms of Texas Instruments standard warranty. Production processing does not necessarily include testing of all parameters.

**TEXAS
INSTRUMENTS**

POST OFFICE BOX 225012 • DALLAS, TEXAS 75265

TYPE SN74172 16-BIT MULTIPLE-PORT REGISTER FILE WITH 3-STATE OUTPUTS

description (continued)

The three-state outputs of this register file permit connection of up to 129 compatible outputs and one Series 54/74 high-logic-level load to a common system bus. The outputs are controlled by the read-enable circuitry so that they operate as standard TTL totem-pole outputs when the appropriate read-enable input is low or they are placed in a high-impedance state when the associated read-enable input is at a high logic level. To minimize the possibility that two outputs from separate register files will attempt to take a common bus to opposite logic levels, the read-enable circuitry is designed such that disable times are shorter than enable times.

All inputs are buffered to lower the drive requirements of the clock, read/write address, and write-enable inputs to one normalized Series 54/74 load, and of all other inputs to one-half of one normalized Series 54/74 load.

Functions of the inputs and outputs of the SN74172 are as shown in the following table.

FUNCTION	SECTION 1	SECTION 2	DESCRIPTION
Write Address	1W0, 1W1, 1W2	2W/R0, 2W/R1, 2W/R2	Binary write address selects one of eight two-bit word locations.
Write Enable	$1\overline{GW}$	$2\overline{GW}$	When low, permits the writing of new data into the selected word location on a positive transition of the clock input.
Data Inputs	1DA, 1DB	2DA, 2DB	Data at these inputs is entered on a positive transition of the clock input into the location selected by the write address inputs if the write enable input is low. Since the two sections are independent, it is possible for both write functions to be activated with both write addresses selecting the same word location. If this occurs and the information at the data inputs is not the same for both sections (i.e., $1DA \neq 2DA$ and/or $1DB \neq 2DB$) the low-level data will predominate in each bit and be stored.
Read Address	1R0, 1R1, 1R2	Common with write address	Binary write address selects one of eight two-bit word locations.
Read Enable	$1\overline{GR}$	$2\overline{GR}$	When read enable is low, the outputs assume the levels of the data stored in the location selected by read address inputs. When read enable is high, the associated outputs remain in the high-impedance state and neither significantly load nor drive the lines to which they are connected.
Data Outputs	1QA, 1QB	2QA, 2QB	
Clock	CK		The positive-going transition of the clock input will enter new data into the addressed location if the write enable input is low. The clock is common to both sections.

TYPE SN74172
16-BIT MULTIPLE-PORT REGISTER FILE WITH 3-STATE OUTPUTS

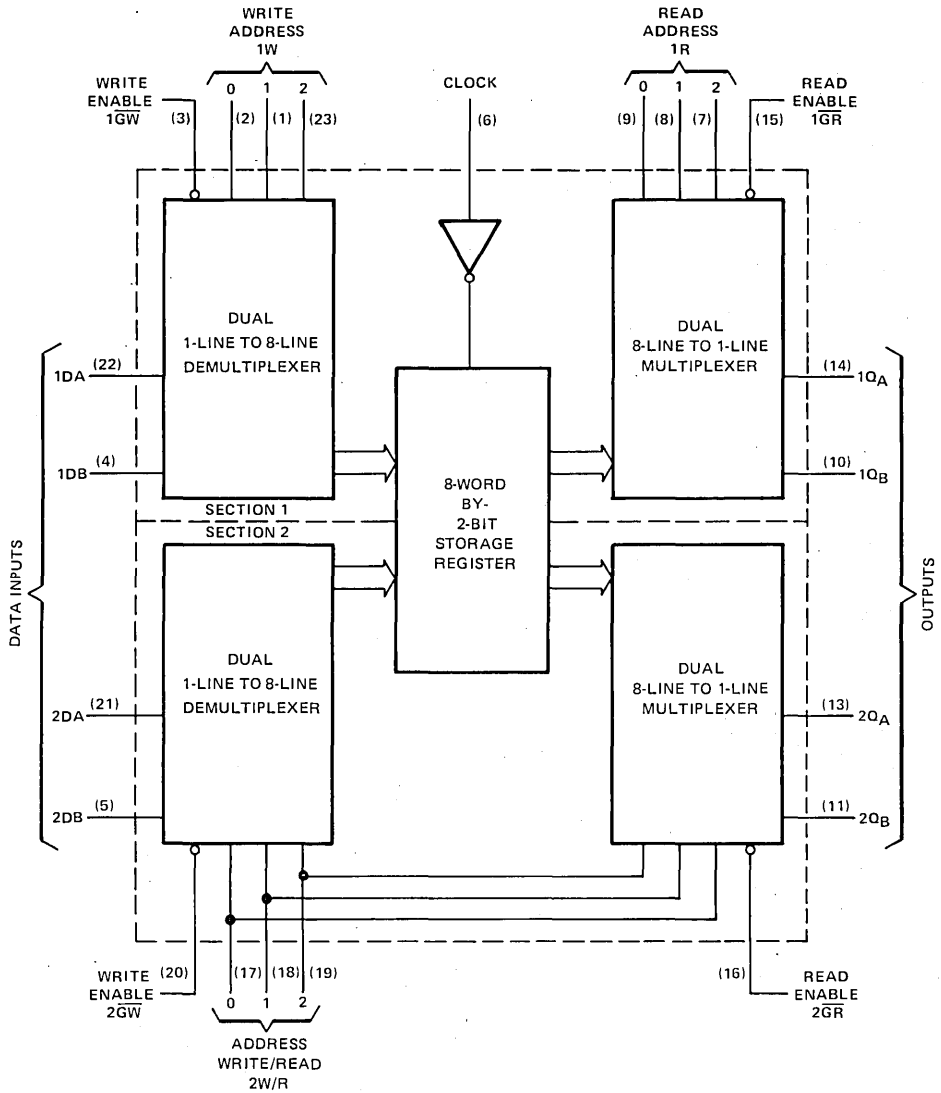

FIGURE 1

3

TTL DEVICES

TYPE SN74172

16-BIT MULTIPLE-PORT REGISTER FILE WITH 3-STATE OUTPUTS

absolute maximum ratings over operating free-air temperature range (unless otherwise noted)

Supply voltage (see Note 1)	7 V
Input voltage	5.5 V
Output voltage (see Note 2)	5.5 V
Operating free-air temperature range	0°C to 70°C
Storage temperature	-65°C to 150°C

- NOTES: 1. Voltage values are with respect to network ground terminal.
 2. This is the maximum voltage which should be applied to any output when it is in the high-impedance state.

recommended operating conditions

		MIN	NOM	MAX	UNIT
Supply voltage, V_{CC}		4.75	5	5.25	V
High-level output current, I_{OH}				-5.2	mA
Low-level output current, I_{OL}				16	mA
Clock frequency, f_{clock}		0		20	MHz
Width of clock pulse, $t_w(\text{clock})$		25			ns
Setup time, t_{SU} (see Figure 1)	Write select	$t_w(\text{clock})+10$			ns
	High-level data	30			
	Low-level data	45			
	Write enable	35			
Hold time, t_H (see Figure 1)	Write select	0			ns
	Write enable	0			
Data release time, $t_{release}$ (see Figure 1)	High-level data	0			ns
	Low-level data	0			
Operating free-air temperature, T_A		0		70	°C

electrical characteristics over recommended operating free-air temperature range (unless otherwise noted)

PARAMETER		TEST CONDITIONS†	MIN	TYP‡	MAX	UNIT
V_{IH}	High-level input voltage		2			V
V_{IL}	Low-level input voltage			0.8		V
V_{IK}	Input clamp voltage	$V_{CC} = \text{MIN}, I_I = -12 \text{ mA}$			-1.5	V
V_{OH}	High-level output voltage	$V_{CC} = \text{MIN}, V_{IH} = 2 \text{ V}, V_{IL} = 0.8 \text{ V}, I_{OH} = -5.2 \text{ mA}$	2.4	3		V
V_{OL}	Low-level output voltage	$V_{CC} = \text{MIN}, V_{IH} = 2 \text{ V}, V_{IL} = 0.8 \text{ V}, I_{OL} = 16 \text{ mA}$	0.2	0.4		V
$I_{O(\text{off})}$	Off-state (high-impedance state) output current	$V_{CC} = \text{MAX}, V_O = 2.4 \text{ V}$		40		μA
		$V_{CC} = \text{MAX}, V_O = 0.4 \text{ V}$		-40		
I_I	Input current at maximum input voltage	$V_{CC} = \text{MAX}, V_I = 5.5 \text{ V}$		1		mA
I_{IH}	High-level input current	$V_{CC} = \text{MAX}, V_I = 2.4 \text{ V}$		40		μA
I_{IL}	Low-level input current	2W/R0, 2W/R1, 2W/R2, 1G̅W, 2G̅W, or clock		-1.6		mA
		Any other input	$V_{CC} = \text{MAX}, V_I = 0.4 \text{ V}$		-0.8	
I_{OS}	Short-circuit output current§	$V_{CC} = \text{MAX}$	-18		-55	mA
I_{CC}	Supply current	$V_{CC} = \text{MAX}, \text{ All inputs at } 4.5 \text{ V}, \text{ Outputs open}$		112	170	mA

† For conditions shown as MIN or MAX, use the appropriate value specified under recommended operating conditions.

‡ All typical values are at $V_{CC} = 5 \text{ V}, T_A = 25^\circ\text{C}$.

§ Not more than one output should be shorted at a time.

3

TTL DEVICES

TYPE SN74172
16-BIT MULTIPLE-PORT REGISTER FILE WITH 3-STATE OUTPUTS

switching characteristics, $V_{CC} = 5\text{ V}$, $T_A = 25^\circ\text{C}$, $R_L = 400\ \Omega$

PARAMETER		TEST CONDITIONS	MIN	TYP	MAX	UNIT
f_{max}	Maximum clock frequency	$C_L = 50\text{ pF}$, See Figure 2	20			MHz
t_{PLH}	Propagation delay time, low-to-high-level output from read select		33	45		ns
t_{PHL}	Propagation delay time, high-to-low-level output from read select		30	45		ns
t_{PLH}	Propagation delay time, low-to-high-level output from clock		35	50		ns
t_{PHL}	Propagation delay time, high-to-low-level output from clock		35	50		ns
t_{pZH}	Output enable time to high level		14	30		ns
t_{pZL}	Output enable time to low level	16	30		ns	
t_{pHZ}	Output disable time from high level	$C_L = 5\text{ pF}$, See Figure 2	6	20		ns
t_{pLZ}	Output disable time from low level		11	20		ns

PARAMETER MEASUREMENT INFORMATION

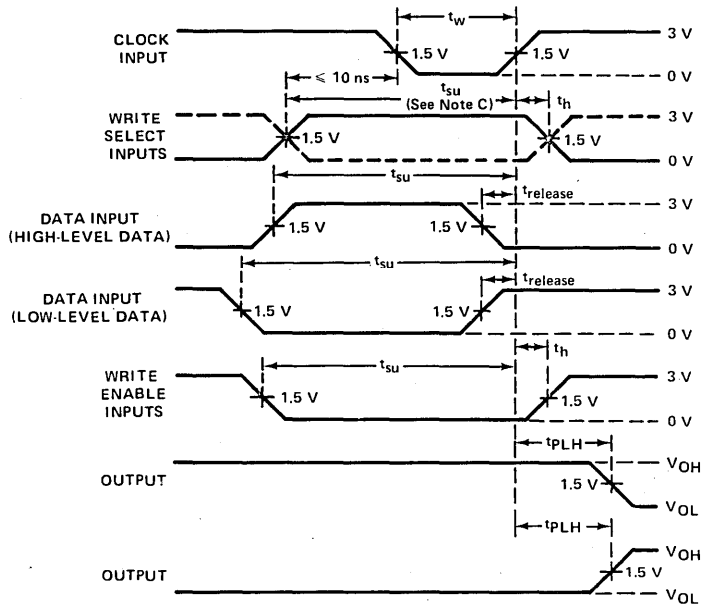

SWITCHING TIMES FROM CLOCK INPUT

VOLTAGE WAVEFORMS

FIGURE 2

6

TTL DEVICES

TYPE SN74172
16-BIT MULTIPLE-PORT REGISTER FILE WITH 3-STATE OUTPUTS

PARAMETER MEASUREMENT INFORMATION

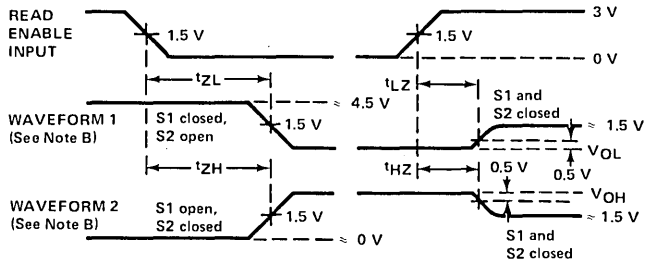

ENABLE AND DISABLE TIMES FROM READ ENABLE

- NOTES: A. Input waveforms are supplied by pulse generators having the following characteristics: $t_r \leq 7$ ns, $t_f \leq$ ns, PRR = 1 MHz, $Z_{out} \approx 50 \Omega$.
- B. Waveform 1 is for an output with internal conditions such that the output is low except when disabled. Waveform 2 is for an output with internal conditions such that the output is high except when disabled.
- C. Write select setup time, as specified, will protect data written into previous address.
- D. Load circuit is shown on page .

VOLTAGE WAVEFORMS
FIGURE 2 (continued)

TYPES SN54173, SN54LS173A, SN74173, SN74LS173A 4-BIT D-TYPE REGISTERS WITH 3-STATE OUTPUTS

OCTOBER 1976—REVISED APRIL 1985

- 3-State Outputs Interface Directly with System Bus
- Gated Output-Control Lines for Enabling or Disabling the Outputs
- Fully Independent Clock Virtually Eliminates Restrictions for Operating in One of Two Modes:

Parallel Load
Do Nothing (Hold)

- For application as Bus Buffer Registers

SN54173, SN54LS173A ... J OR W PACKAGE
SN74173 ... J OR N PACKAGE
SN74LS173A ... D, J OR N PACKAGE

(TOP VIEW)

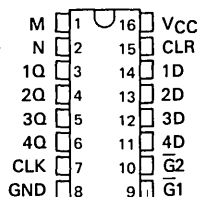

SN54LS173A ... FK PACKAGE
SN74LS173A ... FN PACKAGE

(TOP VIEW)

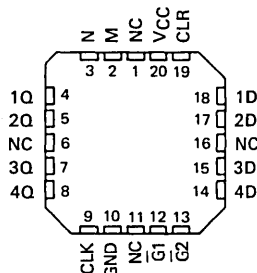

NC - No internal connection

TYPE	TYPICAL PROPAGATION DELAY TIME	MAXIMUM CLOCK FREQUENCY	TYPICAL POWER DISSIPATION
'173	23 ns	35 MHz	250 mW
'LS173A	18 ns	50 MHz	95 mW

description

The '173 and 'LS173A four-bit registers include D-type flip-flops featuring totem-pole three-state outputs capable of driving highly capacitive or relatively low-impedance loads. The high-impedance third state and increased high-logic-level drive provide these flip-flops with the capability of being connected directly to and driving the bus lines in a bus-organized system without need for interface or pull-up components. Up to 128 of the SN74173 or SN74LS173A outputs may be connected to a common bus and still drive two Series 54/74 or 54LS/74LS TTL normalized loads, respectively. Similarly, up to 49 of the SN54173 or SN54LS173A outputs can be connected to a common bus and drive one additional Series 54/74 or 54LS/74LS TTL normalized load, respectively. To minimize the possibility that two outputs will attempt to take a common bus to opposite logic levels, the output control circuitry is designed so that the average output disable times are shorter than the average output enable times.

Gated enable inputs are provided on these devices for controlling the entry of data into the flip-flops. When both data-enable inputs are low, data at the D inputs are loaded into their respective flip-flops on the next positive transition of the buffered clock input. Gate output control inputs are also provided. When both are low, the normal logic states (high or low levels) of the four outputs are available for driving the loads or bus lines. The outputs are disabled independently from the level of the clock by a high logic level at either output control input. The outputs then present a high impedance and neither load nor drive the bus line. Detailed operation is given in the function table.

FUNCTION TABLE

CLEAR	CLOCK	DATA ENABLE		DATA D	OUTPUT Q
		$\overline{G1}$	$\overline{G2}$		
H	X	X	X	X	L
L	L	X	X	X	Q_0
L	↑	H	X	X	Q_0
L	↑	X	H	X	Q_0
L	↑	L	L	L	L
L	↑	L	L	H	H

When either M or N (or both) is (are) high the output is disabled to the high-impedance state; however sequential operation of the flip-flops is not affected.

3

TTL DEVICES

TYPES SN54173, SN74173

4-BIT D-TYPE REGISTERS WITH 3-STATE OUTPUTS

recommended operating conditions

		SN54173			SN74173			UNIT
		MIN	NOM	MAX	MIN	NOM	MAX	
Supply voltage, V_{CC}		4.5	5	5.5	4.75	5	5.25	V
High-level output current, I_{OH}					-2			mA
Low-level output current, I_{OL}					16			mA
Input clock frequency, f_{clock}		0			25			MHz
Width of clock or clear pulse, t_w		20			20			ns
Setup time, t_{su}	Data enable	17			17			ns
	Data	10			10			
	Clear inactive state	10			10			
Hold time, t_h	Data enable	2			2			ns
	Data	10			10			
Operating free-air temperature, T_A		-55			125			°C

electrical characteristics over recommended operating free-air temperature range (unless otherwise noted)

PARAMETER		TEST CONDITIONS [†]	MIN	TYP [‡]	MAX	UNIT
V_{IH}	High-level input voltage		2			V
V_{IL}	Low-level input voltage				0.8	V
V_{IK}	Input clamp voltage	$V_{CC} = \text{MIN}, I_I = -12 \text{ mA}$			-1.5	V
V_{OH}	High-level output voltage	$V_{CC} = \text{MIN}, V_{IH} = 2 \text{ V}, V_{IL} = 0.8 \text{ V}, I_{OH} = \text{MAX}$	2.4			V
V_{OL}	Low-level output voltage	$V_{CC} = \text{MIN}, V_{IH} = 2 \text{ V}, V_{IL} = 0.8 \text{ V}, I_{OL} = 16 \text{ mA}$			0.4	V
$I_{O(\text{off})}$	Off-state (high-impedance state) output current	$V_{CC} = \text{MAX}, V_{OH} = 2.4 \text{ V}, V_{IH} = 2 \text{ V}, V_{OL} = 0.4 \text{ V}$	40		-40	μA
I_I	Input current at maximum input voltage	$V_{CC} = \text{MAX}, V_I = 5.5 \text{ V}$	1			mA
I_{IH}	High-level input current	$V_{CC} = \text{MAX}, V_I = 2.4 \text{ V}$	40			μA
I_{IL}	Low-level input current	$V_{CC} = \text{MAX}, V_I = 0.4 \text{ V}$			-1.6	mA
I_{OS}	Short-circuit output current [§]	$V_{CC} = \text{MAX}$	-30		-70	mA
I_{CC}	Supply current	$V_{CC} = \text{MAX},$ See Note 2	50		72	mA

[†]For conditions shown as MIN or MAX, use the appropriate value specified under recommended operating conditions.

[‡]All typical values are at $V_{CC} = 5 \text{ V}, T_A = 25^\circ\text{C}$.

[§]Not more than one output should be shorted at a time.

NOTE 2: I_{CC} is measured with all outputs open; clear grounded following momentary connection to 4.5 V; N, G1, G2, and all data inputs grounded; and the clock input and M at 4.5 V.

switching characteristics, $V_{CC} = 5 \text{ V}, T_A = 25^\circ\text{C}, R_L = 400 \Omega$

PARAMETER		TEST CONDITIONS	MIN	TYP	MAX	UNIT
f_{max}	Maximum clock frequency		25	35		MHz
t_{PHL}	Propagation delay time, high-to-low-level output from clear input	$C_L = 50 \text{ pF},$ See Note 3	18		27	ns
t_{PLH}	Propagation delay time, low-to-high-level output from clock input		28		43	
t_{PHL}	Propagation delay time, high-to-low-level output from clock input		19		31	
t_{PZH}	Output enable time to high level		7	16	30	
t_{PZL}	Output enable time to low level		7	21	30	ns
t_{PHZ}	Output disable time from high level	$C_L = 5 \text{ pF},$ See Note 3	3	5	14	
t_{PLZ}	Output disable time from low level		3	11	20	ns

NOTE 3: See General Information Section for load circuits and voltage waveforms.



TYPES SN54LS173A, SN74LS173A 4-BIT D-TYPE REGISTERS WITH 3-STATE OUTPUTS

recommended operating conditions

	SN54LS173A			SN74LS173A			UNIT
	MIN	NOM	MAX	MIN	NOM	MAX	
Supply voltage, V_{CC}	4.5	5	5.5	4.75	5	5.25	V
High-level output current, I_{OH}			-1			-2.6	mA
Low-level output current, I_{OL}			12			24	mA
Input clock frequency, f_{clock}	0		30	0		30	MHz
Width of clock or clear pulse, t_w		25			25		ns
Setup time, t_{su}	Data enable		35			35	ns
	Data		17			17	
	Clear inactive state		10			10	
Hold time, t_h	Data enable		0			0	ns
	Data		3			3	
Operating free-air temperature, T_A		-55	125		0	70	°C

electrical characteristics over recommended operating free-air temperature range (unless otherwise noted)

PARAMETER	TEST CONDITIONS†	SN54LS173A			SN74LS173A			UNIT	
		MIN	TYP‡	MAX	MIN	TYP‡	MAX		
V_{IH} High-level input voltage		2			2			V	
V_{IL} Low-level input voltage				0.7			0.8	V	
V_{IK} Input clamp voltage	$V_{CC} = \text{MIN}, I_I = -18 \text{ mA}$			-1.5			-1.5	V	
V_{OH} High-level output voltage	$V_{CC} = \text{MIN}, V_{IH} = 2 \text{ V}, V_{IL} = V_{ILmax}, I_{OH} = \text{MAX}$	2.4	3.4		2.4	3.1		V	
V_{OL} Low-level output voltage	$V_{CC} = \text{MIN}, I_{OL} = 12 \text{ mA}$		0.25	0.4		0.25	0.4	V	
	$V_{IL} = 0.8 \text{ V}, I_{OL} = 24 \text{ mA}$					0.35	0.5		
$I_{O(off)}$ Off-state (high-impedance state) output current	$V_{CC} = \text{MAX}, V_{IH} = 2 \text{ V}, V_O = 2.7 \text{ V}$			20			20	µA	
	$V_O = 0.4 \text{ V}$			-20			-20		
I_I Input current at maximum input voltage	$V_{CC} = \text{MAX}, V_I = 7 \text{ V}$			0.1			0.1	mA	
I_{IH} High-level input current	$V_{CC} = \text{MAX}, V_I = 2.7 \text{ V}$			20			20	µA	
I_{IL} Low-level input current	$V_{CC} = \text{MAX}, V_I = 0.4 \text{ V}$			-0.4			-0.4	mA	
I_{OS} Short-circuit output current§	$V_{CC} = \text{MAX}$			-30		-130	-30	-130	mA
I_{CC} Supply current	$V_{CC} = \text{MAX},$ See Note 2		19	30		19	24	mA	

† For conditions shown as MIN or MAX, use the appropriate value specified under recommended operating conditions.

‡ All typical values are at $V_{CC} = 5 \text{ V}, T_A = 25^\circ \text{C}$.

§ Not more than one output should be shorted at a time.

NOTE 2: I_{CC} is measured with all outputs open; clear grounded following momentary connection to 4.5 V; N, G1, G2, and all data inputs grounded; and the clock input and M at 4.5 V.

switching characteristics, $V_{CC} = 5 \text{ V}, T_A = 25^\circ \text{C}, R_L = 667 \Omega$

PARAMETER	TEST CONDITIONS	MIN	TYP	MAX	UNIT
f_{max} Maximum clock frequency			30	50	MHz
t_{PHL} Propagation delay time, high-to-low-level output from clear input	$C_L = 45 \text{ pF},$ See Note 3		26	35	ns
t_{PLH} Propagation delay time, low-to-high-level output from clock input			17	25	ns
t_{PHL} Propagation delay time, high-to-low-level output from clock input			22	30	ns
t_{PZH} Output enable time to high level				15	23
t_{PZL} Output enable time to low level			18	27	
t_{PHZ} Output disable time from high level	$C_L = 5 \text{ pF},$ See Note 3		11	20	ns
t_{PLZ} Output disable time from low level			11	17	

NOTE 3: See General Information Section for load circuits and voltage waveforms.

TYPES SN54174, SN54175, SN54LS174, SN54LS175, SN54S174, SN54S175, SN74174, SN74175, SN74LS174, SN74LS175, SN74S174, SN74S175 HEX/QUADRUPLE D-TYPE FLIP-FLOPS WITH CLEAR

DECEMBER 1972—REVISED DECEMBER 1983

'174, 'LS174, 'S174 ... HEX D-TYPE FLIP-FLOPS '175, 'LS175, 'S175 ... QUADRUPLE D-TYPE FLIP-FLOPS

- '174, 'LS174, 'S174 Contain Six Flip-Flops with Single-Rail Outputs
- '175, 'LS175, 'S175 Contain Four Flip-Flops with Double-Rail Outputs
- Three Performance Ranges Offered: See Table Lower Right
- Buffered Clock and Direct Clear Inputs
- Individual Data Input to Each Flip-Flop
- Applications include:
 - Buffer/Storage Registers
 - Shift Registers
 - Pattern Generators

SN54174, SN54LS174, SN54S174 ... J OR W PACKAGE
SN74174 ... J OR N PACKAGE
SN74LS174, SN74S174 ... D, J OR N PACKAGE

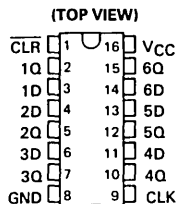

SN54LS174, SN54S174 ... FK PACKAGE
SN74LS174, SN74S174 ... FN PACKAGE

(TOP VIEW)

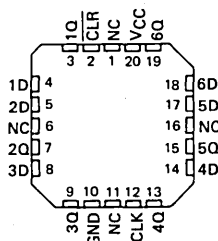

TYPES SN54174, SN54175, SN54LS174, SN54LS175, SN54S174, SN54S175,
 SN74174, SN74175, SN74LS174, SN74LS175, SN74S174, SN74S175
 HEX/QUADRUPLE D-TYPE FLIP-FLOPS WITH CLEAR

logic diagrams

'174, 'LS174, 'S174

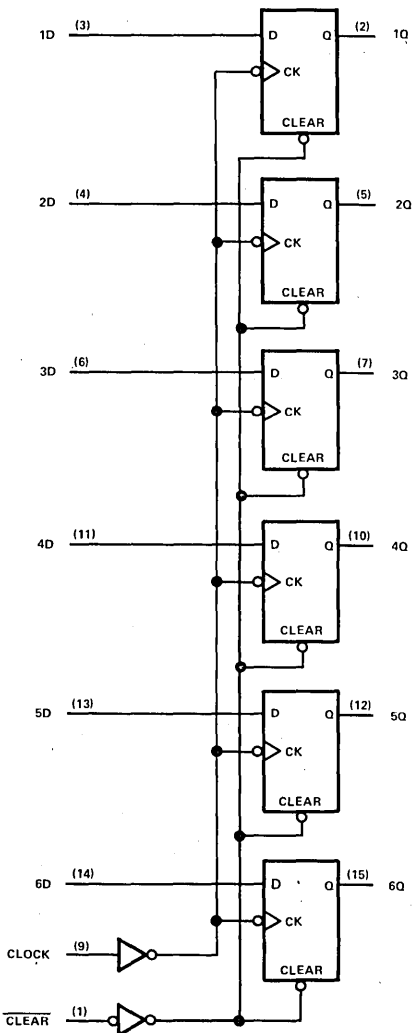

'175, 'LS175, 'S175

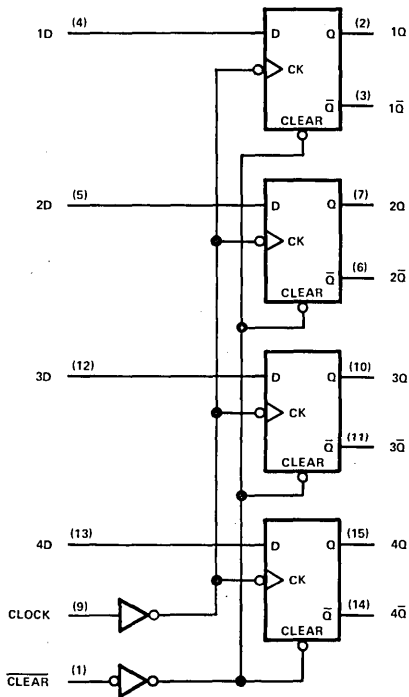

Pin numbers shown on logic notation are for D, J or N packages.

3

TTL DEVICES

TYPES SN54174, SN54175, SN54LS174, SN54LS175, SN54S174, SN54S175,
SN74174, SN74175, SN74LS174, SN74LS175, SN74S174, SN74S175
HEX/QUADRUPLE D-TYPE FLIP-FLOPS WITH CLEAR

schematics of inputs and outputs

SN54174, SN54175, SN74174, SN74175

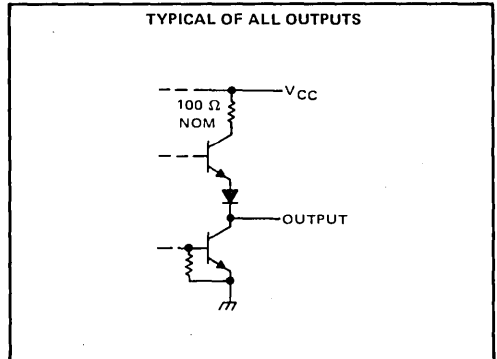
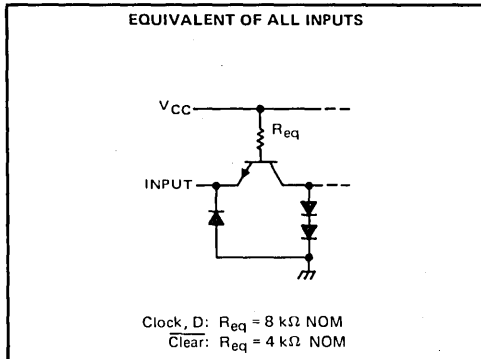

SN54LS174, SN54LS175, SN74LS174, SN74LS175

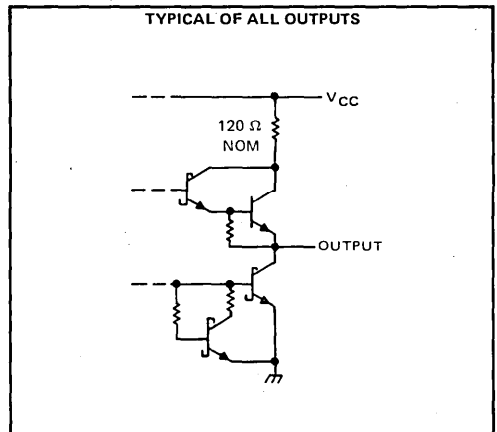
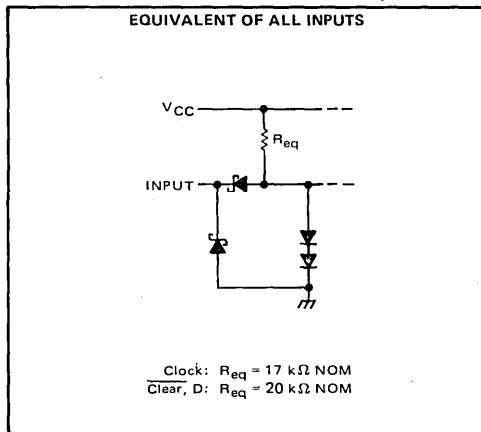

SN54S174, SN54S175, SN74S174, SN74S175

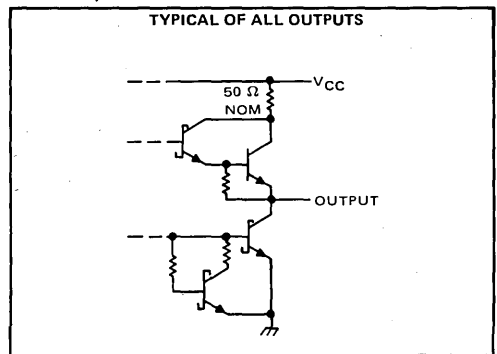
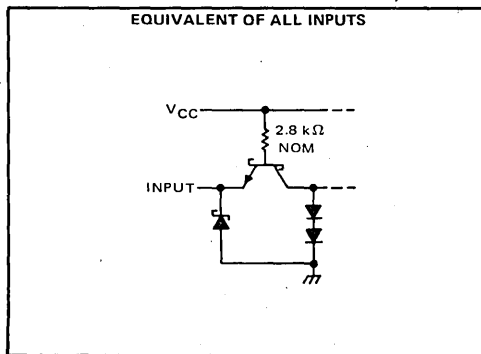

3
TTL DEVICES

TYPES SN54174, SN54175, SN74174, SN74175 HEX/QUADRUPLE D-TYPE FLIP-FLOPS WITH CLEAR

absolute maximum ratings over operating free-air temperature range (unless otherwise noted)

Supply voltage, V_{CC} (see Note 1)	7 V
Input voltage	5.5 V
Operating free-air temperature range: SN54174, SN54175 Circuits	-55°C to 125°C
SN74174, SN74175 Circuits	0°C to 70°C
Storage temperature range	-65°C to 150°C

NOTE 1: Voltage values are with respect to network ground terminal.

recommended operating conditions

	SN54174, SN54175			SN74174, SN74175			UNIT
	MIN	NOM	MAX	MIN	NOM	MAX	
Supply voltage, V_{CC}	4.5	5	5.5	4.75	5	5.25	V
High-level output current, I_{OH}			-800			-800	μ A
Low-level output current, I_{OL}			16			16	mA
Clock frequency, f_{clock}	0		25	0		25	MHz
Width of clock or clear pulse, t_w	20			20			ns
Setup time, t_{su}	Data input	20		20			ns
	Clear inactive-state	25		25			ns
Data hold time, t_h	5			5			ns
Operating free-air temperature, T_A	-55		125	0		70	°C

electrical characteristics over recommended operating free-air temperature range (unless otherwise noted)

PARAMETER	TEST CONDITIONS†	MIN	TYP‡	MAX	UNIT
V_{IH} High-level input voltage		2			V
V_{IL} Low-level input voltage				0.8	V
V_{IK} Input clamp voltage	$V_{CC} = \text{MIN}$, $I_I = -12 \text{ mA}$			-1.5	V
V_{OH} High-level output voltage	$V_{CC} = \text{MIN}$, $V_{IH} = 2 \text{ V}$, $V_{IL} = 0.8 \text{ V}$, $I_{OH} = -800 \mu\text{A}$	2.4	3.4		V
V_{OL} Low-level output voltage	$V_{CC} = \text{MIN}$, $V_{IH} = 2 \text{ V}$, $V_{IL} = 0.8 \text{ V}$, $I_{OL} = 16 \text{ mA}$		0.2	0.4	V
I_I Input current at maximum input voltage	$V_{CC} = \text{MAX}$, $V_I = 5.5 \text{ V}$			1	mA
I_{IH} High-level input current	$V_{CC} = \text{MAX}$, $V_I = 2.4 \text{ V}$			40	μ A
I_{IL} Low-level input current	$V_{CC} = \text{MAX}$, $V_I = 0.4 \text{ V}$			-1.6	mA
I_{OS} Short-circuit output current§	$V_{CC} = \text{MAX}$	SN54'	-20	-57	mA
		SN74'	-18	-57	mA
I_{CC} Supply current	$V_{CC} = \text{MAX}$, See Note 2	'174	45	65	mA
		'175	30	45	mA

†For conditions shown as MIN or MAX, use the appropriate value specified under recommended operating conditions for the applicable device type.

‡All typical values are at $V_{CC} = 5 \text{ V}$, $T_A = 25^\circ\text{C}$.

§Not more than one output should be shorted at a time.

NOTE 2: With all outputs open and 4.5 V applied to all data and clear inputs, I_{CC} is measured after a momentary ground, then 4.5 V, is applied to clock.

switching characteristics, $V_{CC} = 5 \text{ V}$, $T_A = 25^\circ\text{C}$

PARAMETER	TEST CONDITIONS	MIN	TYP	MAX	UNIT
f_{max} Maximum clock frequency		25	35		MHz
t_{PLH} Propagation delay time, low-to-high-level output from clear (SN54175, SN74175 only)	$C_L = 15 \text{ pF}$, $R_L = 400 \Omega$, See Note 3		16	25	ns
t_{PHL} Propagation delay time, high-to-low-level output from clear			23	35	ns
t_{PLH} Propagation delay time, low-to-high-level output from clock			20	30	ns
t_{PHL} Propagation delay time, high-to-low-level output from clock			24	35	ns

NOTE 3: See General Information Section for load circuits and voltage waveforms.

TYPES SN54LS174, SN54LS175, SN74LS174, SN74LS175 HEX/QUADRUPLE D-TYPE FLIP-FLOPS WITH CLEAR

absolute maximum ratings over operating free-air temperature range (unless otherwise noted)

Supply voltage, V_{CC} (see Note 1)	7 V
Input voltage	7 V
Operating free-air temperature range: SN54LS174, SN54LS175 Circuits	-55°C to 125°C
SN74LS174, SN74LS175 Circuits	0°C to 70°C
Storage temperature range	-65°C to 150°C

NOTE 1: Voltage values are with respect to network ground terminal.

recommended operating conditions

	SN54LS174 SN54LS175			SN74LS174 SN74LS175			UNIT		
	MIN	NOM	MAX	MIN	NOM	MAX			
Supply voltage, V_{CC}	4.5	5	5.5	4.75	5	5.25	V		
High-level output current, I_{OH}	-400			-400			μ A		
Low-level output current, I_{OL}	4			8			mA		
Clock frequency, f_{clock}	0			30			MHz		
Width of clock or clear pulse, t_w	20			20			ns		
Setup time, t_{SU}	Data input			20			ns		
	Clear inactive-state			25			ns		
Data hold time, t_H	5			5			ns		
Operating free-air temperature, T_A	-55			125			0	70	°C

electrical characteristics over recommended operating free-air temperature range (unless otherwise noted)

PARAMETER	TEST CONDITIONS†	SN54LS174 SN54LS175			SN74LS174 SN74LS175			UNIT	
		MIN	TYP‡	MAX	MIN	TYP‡	MAX		
V_{IH} High-level input voltage		2			2			V	
V_{IL} Low-level input voltage		0.7			0.8			V	
V_{IK} Input clamp voltage	$V_{CC} = \text{MIN}, I_I = -18 \text{ mA}$	-1.5			-1.5			V	
V_{OH} High-level output voltage	$V_{CC} = \text{MIN}, V_{IH} = 2 \text{ V}, V_{IL} = V_{IL \text{ max}}, I_{OH} = -400 \mu\text{A}$	2.5	3.5		2.7	3.5		V	
V_{OL} Low-level output voltage	$V_{CC} = \text{MIN}, V_{IH} = 2 \text{ V}, V_{IL} = V_{IL \text{ max}}$	$I_{OL} = 4 \text{ mA}$ $I_{OL} = 8 \text{ mA}$		0.25	0.4	0.25	0.4	V	
I_I Input current at maximum input voltage	$V_{CC} = \text{MAX}, V_I = 7 \text{ V}$	0.1			0.1			mA	
I_{IH} High-level input current	$V_{CC} = \text{MAX}, V_I = 2.7 \text{ V}$	20			20			μ A	
I_{IL} Low-level input current	$V_{CC} = \text{MAX}, V_I = 0.4 \text{ V}$	-0.4			-0.4			mA	
I_{OS} Short-circuit output current §	$V_{CC} = \text{MAX}$	-20	-100		-20	-100		mA	
I_{CC} Supply current	$V_{CC} = \text{MAX},$ See Note 2	'LS174			16			26	mA
		'LS175			11			18	

† For conditions shown as MIN or MAX, use the appropriate value specified under recommended operating conditions.

‡ All typical values are at $V_{CC} = 5 \text{ V}, T_A = 25^\circ\text{C}$.

§ Not more than one output should be shorted at a time, and duration of the short-circuit should not exceed one second.

NOTE 2: With all outputs open and 4.5 V applied to all data and clear inputs, I_{CC} is measured after a momentary ground, then 4.5 V, is applied to clock.

switching characteristics, $V_{CC} = 5 \text{ V}, T_A = 25^\circ\text{C}$

PARAMETER	TEST CONDITIONS	'LS174			'LS175			UNIT	
		MIN	TYP	MAX	MIN	TYP	MAX		
f_{max} Maximum clock frequency	$C_L = 15 \text{ pF},$ $R_L = 2 \text{ k}\Omega,$ See Note 3	30	40		30	40		MHz	
t_{PLH} Propagation delay time, low-to-high-level output from clear					20	30	ns		
t_{PHL} Propagation delay time, high-to-low-level output from clear					23	35	ns		
t_{PLH} Propagation delay time, low-to-high-level output from clock					20	30	13	25	ns
t_{PHL} Propagation delay time, high-to-low-level output from clock					21	30	16	25	ns

NOTE 3: See General Information Section for load circuits and voltage waveforms.

TEXAS
INSTRUMENTS

POST OFFICE BOX 225012 • DALLAS, TEXAS 75265

3-693

3

TTL DEVICES

TYPES SN54S174, SN54S175, SN74S174, SN74S175 HEX/QUADRUPLE D-TYPE FLIP-FLOPS WITH CLEAR

absolute maximum ratings over operating free-air temperature range (unless otherwise noted)

Supply voltage, V_{CC} (see Note 1)	7 V
Input voltage	5.5 V
Operating free-air temperature range: SN54S174, SN54S175 Circuits	-55°C to 125°C
SN74S174, SN74S175 Circuits	0°C to 70°C
Storage temperature range	-65°C to 150°C

NOTE 1: Voltage values are with respect to network ground terminal.

recommended operating conditions

	SN54S174, SN54S175			SN74S174, SN74S175			UNIT
	MIN	NOM	MAX	MIN	NOM	MAX	
Supply voltage, V_{CC}	4.5	5	5.5	4.75	5	5.25	V
High-level output current, I_{OH}			-1			-1	mA
Low-level output current, I_{OL}			20			20	mA
Clock frequency, f_{clock}		0	75		0	75	MHz
Pulse width, t_w	Clock		7			7	ns
	Clear		10			10	
Setup time, t_{su}	Data input		5			5	ns
	Clear inactive-state		5			5	
Data hold time, t_h			3			3	ns
Operating free-air temperature, T_A		-55	125		0	70	°C

electrical characteristics over recommended operating free-air temperature range (unless otherwise noted)

PARAMETER	TEST CONDITIONS [†]	MIN	TYP [‡]	MAX	UNIT	
V_{IH} High-level input voltage		2			V	
V_{IL} Low-level input voltage				0.8	V	
V_{IK} Input clamp voltage	$V_{CC} = \text{MIN}, I_I = -18 \text{ mA}$			-1.2	V	
V_{OH} High-level output voltage	$V_{CC} = \text{MIN}, V_{IH} = 2 \text{ V}, V_{IL} = 0.8 \text{ V}, I_{OH} = -1 \text{ mA}$	SN54S'	2.5	3.4	V	
		SN74S'	2.7	3.4		
V_{OL} Low-level output voltage	$V_{CC} = \text{MIN}, V_{IH} = 2 \text{ V}, V_{IL} = 0.8 \text{ V}, I_{OL} = 20 \text{ mA}$			0.5	V	
I_I Input current at maximum input voltage	$V_{CC} = \text{MAX}, V_I = 5.5 \text{ V}$			1	mA	
I_{IH} High-level input current	$V_{CC} = \text{MAX}, V_I = 2.7 \text{ V}$			50	μA	
I_{IL} Low-level input current	$V_{CC} = \text{MAX}, V_I = 0.5 \text{ V}$			-2	mA	
I_{OS} Short-circuit output current [§]	$V_{CC} = \text{MAX}$			-40	-100	mA
I_{CC} Supply current	$V_{CC} = \text{MAX}, \text{ See Note 2}$	'174	90	144	mA	
		'175	60	96		

[†] For conditions shown as MIN or MAX, use the appropriate value specified under recommended operating conditions for the applicable device type.

[‡] All typical values are at $V_{CC} = 5 \text{ V}, T_A = 25^\circ \text{C}$.

[§] Not more than one output should be shorted at a time, and duration of the short-circuit should not exceed one second.

NOTE 2: With all outputs open and 4.5 V applied to all data and clear inputs, I_{CC} is measured after a momentary ground, then 4.5 V, is applied to clock.

switching characteristics, $V_{CC} = 5 \text{ V}, T_A = 25^\circ \text{C}$

PARAMETER	TEST CONDITIONS	MIN	TYP	MAX	UNIT
f_{max} Maximum clock frequency		75	110		MHz
t_{PLH} Propagation delay time, low-to-high-level Q output from clear (SN54S175, SN74S175 only)	$C_L = 15 \text{ pF}, R_L = 280 \Omega, \text{ See Note 3}$		10	15	ns
		t_{PHL} Propagation delay time, high-to-low-level Q output from clear	13	22	ns
t_{PLH} Propagation delay time, low-to-high-level output from clock		8	12	ns	
t_{PHL} Propagation time, high-to-low-level output from clock		11.5	17	ns	

NOTE 3: See General Information Section for load circuits and voltage waveforms.

TYPES SN54176, SN54177, SN74176, SN74177 35-MHz PRESETTABLE DECADE AND BINARY COUNTERS/LATCHES

MAY 1971—REVISED DECEMBER 1983

- Reduced-Power Versions of SN54196, SN54197, SN74196, and SN74197 50-MHz Counters
- D-C Coupled Counters Designed to Replace Signetics 8280, 8281, 8290, and 8291 Counters in Most Applications
- Performs BCD, Bi-Quinary, or Binary Counting
- Fully Programmable
- Fully Independent Clear Input
- Guaranteed to Count at Input Frequencies from 0 to 35 MHz
- Input Clamping Diodes Simplify System Design

SN54176, SN54177 ... J OR W PACKAGE
SN74176, SN74177 ... J OR N PACKAGE
(TOP VIEW)

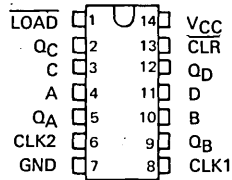

description

These high-speed monolithic counters consist of four d-c coupled master-slave flip-flops which are internally interconnected to provide either a divide-by-two and a divide-by-five counter (SN54176, SN74176) or a divide-by-two and a divide-by-eight counter (SN54177, SN74177). These counters are fully programmable; that is, the outputs may be preset to any state by placing a low on the count/load input and entering the desired data at the data inputs. The outputs will change to agree with the data inputs independent of the state of the clocks.

These counters may also be used as 4-bit latches by using the count/load input as the strobe and entering data at the data inputs. The outputs will directly follow the data inputs when the count/load is low, but will remain unchanged when the count/load is high and the clock inputs are inactive.

These high-speed counters will accept count frequencies of 0 to 35 megahertz at the clock-1 input and 0 to 17.5 megahertz at the clock-2 input. During the count operation, transfer of information to the outputs occurs on the negative-going edge of the clock pulse. The counters feature a direct clear which when taken low sets all outputs low regardless of the states of the clocks.

All inputs are diode-clamped to minimize transmission-line effects and simplify system design. The circuits are compatible with most TTL logic families. Typical power dissipation is 150 milliwatts. The SN54176 and SN54177 circuits are characterized for operation over the full military temperature range of -55°C to 125°C ; the SN74176 and SN74177 circuits are characterized for operation from 0°C to 70°C .

3

TTL DEVICES

PRODUCTION DATA

This document contains information current as of publication date. Products conform to specifications per the terms of Texas Instruments standard warranty. Production processing does not necessarily include testing of all parameters.

TEXAS
INSTRUMENTS

POST OFFICE BOX 225012 • DALLAS, TEXAS 75265

3-695

TYPES SN54176, SN54177, SN74176, SN74177 35-MHz PRESETTABLE DECADE AND BINARY COUNTERS/LATCHES

typical count configurations

SN54176 and SN74176

The output of flip-flop A is not internally connected to the succeeding flip-flops; therefore, the count may be operated in three independent modes:

- When used as a binary-coded-decimal decade counter, the clock-2 input must be externally connected to the Q_A output. The clock-1 input receives the incoming count, and a count sequence is obtained in accordance with the BCD count sequence function table shown at right.
- If a symmetrical divide-by-ten count is desired for frequency synthesizers (or other applications requiring division of a binary count by a power of ten), the Q_D output must be externally connected to the clock-1 input. The input count is then applied at the clock-2 input and a divide-by-ten square wave is obtained at output Q_A in accordance with the bi-quinary function table.
- For operation as a divide-by-two counter and a divide-by-five counter, no external interconnections are required. Flip-flop A is used as a binary element for the divide-by-two function. The clock-2 input is used to obtain binary divide-by-five operation at the Q_B , Q_C , and Q_D outputs. In this mode, the two counters operate independently; however, all four flip-flops are loaded and cleared simultaneously.

FUNCTION TABLES
SN54176, SN74176

DECADE (BCD)
(See Note A)

COUNT	OUTPUT			
	Q_D	Q_C	Q_B	Q_A
0	L	L	L	L
1	L	L	L	H
2	L	L	H	L
3	L	L	H	H
4	L	H	L	L
5	L	H	L	H
6	L	H	H	L
7	L	H	H	H
8	H	L	L	L
9	H	L	L	H

BI-QUINARY (5-2)
(See Note B)

COUNT	OUTPUT			
	Q_A	Q_D	Q_C	Q_B
0	L	L	L	L
1	L	L	L	H
2	L	L	H	L
3	L	L	H	H
4	L	H	L	L
5	H	L	L	L
6	H	L	L	H
7	H	L	H	L
8	H	L	H	H
9	H	H	L	L

H = high level, L = low level

NOTES: A. Output Q_A connected to clock-2 input.
B. Output Q_D connected to clock-1 input.

SN54177 and SN74177

The output of flip-flop A is not internally connected to the succeeding flip-flops, therefore the counter may be operated in two independent modes:

- When used as a high-speed 4-bit ripple-through counter, output Q_A must be externally connected to the clock-2 input. The input count pulses are applied to the clock-1 input. Simultaneous divisions by 2, 4, 8, and 16 are performed at the Q_A , Q_B , Q_C , and Q_D outputs as shown in the function table at right.
- When used as a 3-bit ripple-through counter, the input count pulses are applied to the clock-2 input. Simultaneous frequency divisions by 2, 4, and 8 are available at the Q_B , Q_C , and Q_D outputs. Independent use of flip-flop A is available if the load and clear functions coincide with those of the 3-bit ripple-through counter.

FUNCTION TABLE
SN54177, SN74177
(See Note A)

COUNT	OUTPUT			
	Q_D	Q_C	Q_B	Q_A
0	L	L	L	L
1	L	L	L	H
2	L	L	H	L
3	L	L	H	H
4	L	H	L	L
5	L	H	L	H
6	L	H	H	L
7	L	H	H	H
8	H	L	L	L
9	H	L	L	H
10	H	L	H	L
11	H	L	H	H
12	H	H	L	L
13	H	H	L	H
14	H	H	H	L
15	H	H	H	H

H = high level, L = low level

NOTE A: Output Q_A connected to clock-2 input.

SN54176, SN74176

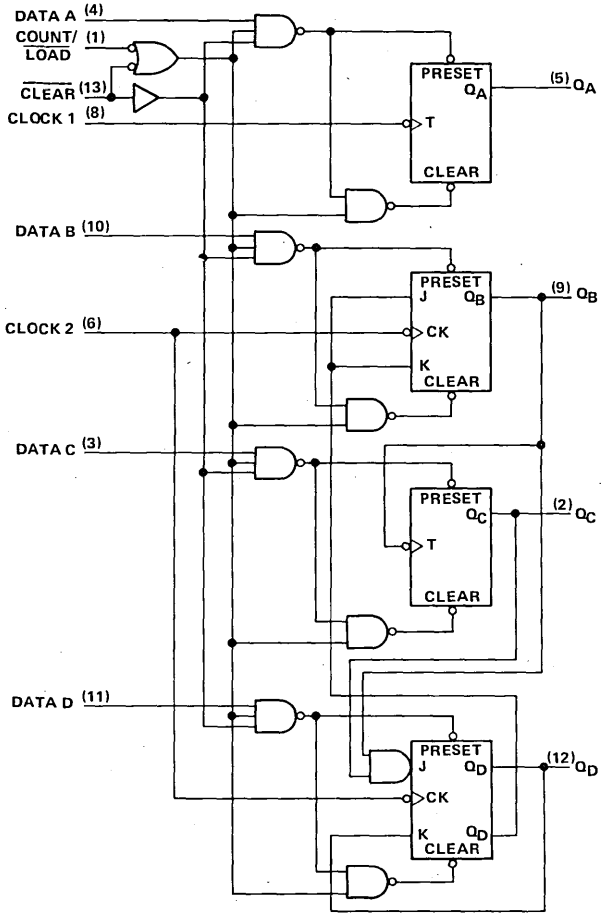

SN54177, SN74177

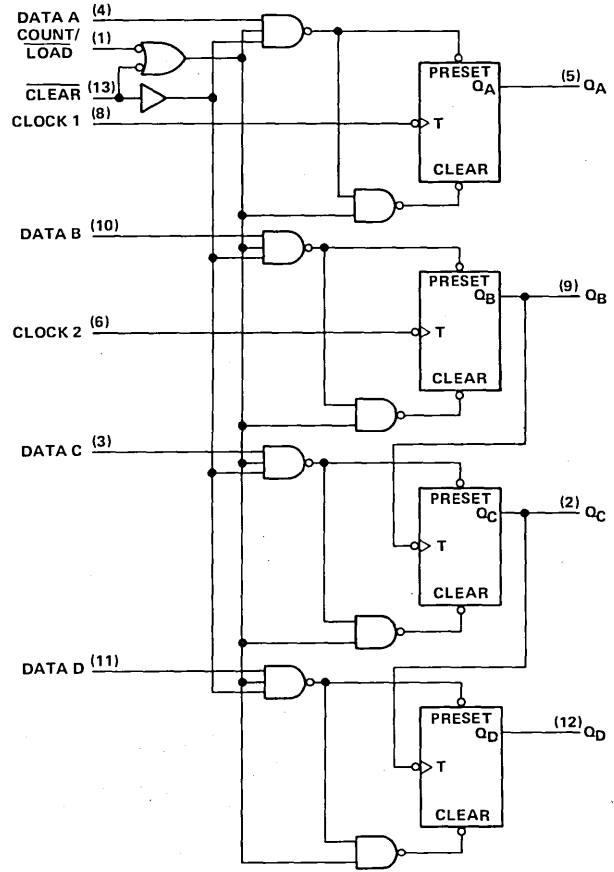

Pin numbers shown on logic notation are for J or N packages.



TYPES SN54176, SN54177, SN74176, SN74177

35-MHz PRESETTABLE DECADE AND BINARY COUNTERS/LATCHES

schematics of inputs and outputs

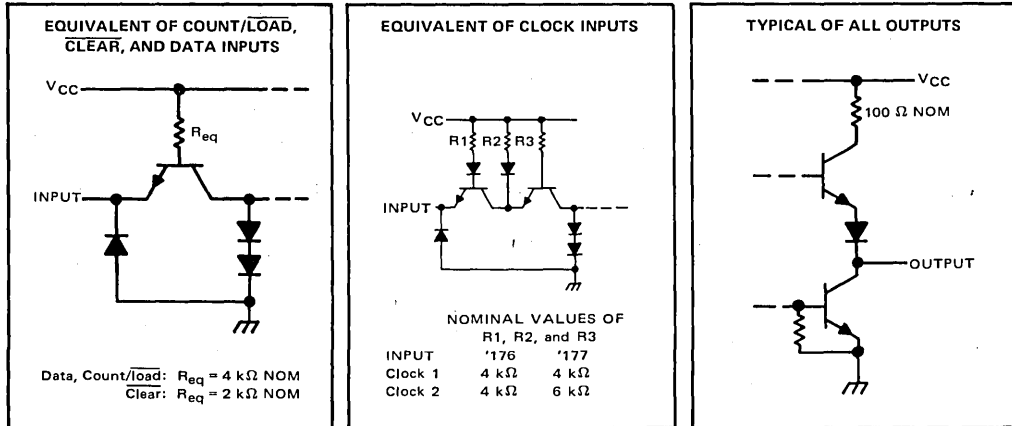

absolute maximum ratings over operating free-air temperature range (unless otherwise noted)

Supply voltage, V_{CC} (see Note 1)	7 V
Input voltage	5.5 V
Interemitter voltage (see Note 2)	5.5 V
Operating free-air temperature range: SN54176, SN54177 Circuits	-55°C to 125°C
SN74176, SN74177 Circuits	0°C to 70°C
Storage temperature range	-65°C to 150°C

- NOTES: 1. Voltage values are with respect to network ground terminal.
2. This is the voltage between two emitters of a multiple-emitter transistor. For this circuit, this rating applies between the clear and count/load inputs.

recommended operating conditions

		MIN	NOM	MAX	UNIT
Supply voltage, V_{CC}	SN54'	4.5	5	5.5	V
	SN74'	4.75	5	5.25	
High-level output current, I_{OH}				-800	μ A
Low-level output current, I_{OL}				16	mA
Count frequency (see Figure 1)	Clock-1 input	0		35	MHz
	Clock-2 input	0		17.5	
Pulse width, t_w (see Figure 1)	Clock-1 input	14			ns
	Clock-2 input	28			
	Clear	20			
	Load	25			
	High-level data	$t_w(\text{load})$			
Input hold time, t_h (see Figure 1)	High-level data	$t_w(\text{load})$			ns
	Low-level data	$t_w(\text{load})$			
Input setup time, t_{SU} (see Figure 1)	High-level data	15			ns
	Low-level data	20			
Count enable time, t_{enable} (see Note 3 and Figure 1)			25		ns
Operating free-air temperature, T_A	SN54'	-55		125	°C
	SN74'	0		70	

NOTE 3: Minimum count enable time is the interval immediately preceding the negative-going edge of the clock pulse during which interval the count/load and clear inputs must both be high to ensure counting.

3

TTL DEVICES

TYPES SN54176, SN54177, SN74176, SN74177
35-MHz PRESETTABLE DECADE AND
BINARY COUNTERS/LATCHES

electrical characteristics over recommended operating free-air temperature range (unless otherwise noted)

PARAMETER		TEST CONDITIONS†	SN54176, SN74176			SN54177, SN74177			UNIT
			MIN	TYP‡	MAX	MIN	TYP‡	MAX	
V _{IH}	High-level input voltage		2			2			V
V _{IL}	Low-level input voltage		0.8			0.8			V
V _{IK}	Input clamp voltage	V _{CC} = MIN, I _I = -12 mA	-1.5			-1.5			V
V _{OH}	High-level output voltage	V _{CC} = MIN, V _{IH} = 2 V, V _{IL} = 0.8 V, I _{OH} = -800 µA	2.4	3.4		2.4	3.4		V
V _{OL}	Low-level output voltage	V _{CC} = MIN, V _{IH} = 2 V, V _{IL} = 0.8 V, I _{OL} = 16 mA¶	0.2	0.4		0.2	0.4		V
I _I	Input current at maximum input voltage	V _{CC} = MAX, V _I = 5.5 V	1			1			mA
I _{IH}	High-level input current	Data, count/load	40			40			µA
		Clear, clock 1	80			80			
		Clock 2	120			80			
I _{IL}	Low-level input current	Data, count/load	-1.6			-1.6			mA
		Clear	-3.2			-3.2			
		Clock 1	-4.8			-4.8			
		Clock 2	-4.8			-3.2			
I _{OS}	Short-circuit output current §	V _{CC} = MAX	SN54*	-20	-57	-20	-57	mA	
			SN74*	-18	-57	-18	-57		
I _{CC}	Supply current	V _{CC} = MAX, See Note 4	30	48		30	48	mA	

† For conditions shown as MIN or MAX, use the appropriate value specified under recommended operation conditions.

‡ All typical values are at V_{CC} = 5 V, T_A = 25°C.

¶ Q_A outputs are tested at I_{OL} = 16 mA plus the limit value of I_{IL} for the clock-2 input. This permits driving the clock-2 input while fanning out to 10 Series 54/74 loads.

§ Not more than one output should be shorted at a time.

NOTE 4: I_{CC} is measured with all inputs grounded and all outputs open.

switching characteristics, V_{CC} = 5 V, R_L = 400 Ω, C_L = 15 pF, T_A = 25°C, see figure 1

PARAMETER ^Q	FROM (INPUT)	TO (OUTPUT)	SN54176, SN74176			SN54177, SN54177			UNIT
			MIN	TYP	MAX	MIN	TYP	MAX	
f _{max}	Clock 1	Q _A	35	50		35	50		MHz
t _{PLH}	Clock 1	Q _A	8	13		8	13		ns
t _{PHL}			11	17		11	17		
t _{PLH}	Clock 2	Q _B	11	17		11	17		ns
t _{PHL}			17	26		17	26		
t _{PLH}	Clock 2	Q _C	27	41		27	41		ns
t _{PHL}			34	51		34	51		
t _{PLH}	Clock 2	Q _D	13	20		44	66		ns
t _{PHL}			17	26		50	75		
t _{PLH}	A, B, C, D	Q _A , Q _B , Q _C , Q _D	19	29		19	29		ns
t _{PHL}			31	46		31	46		
t _{PLH}	Load	Any	29	43		29	43		ns
t _{PHL}			32	48		32	48		
t _{PHL}	Clear	Any	32	48		32	48	ns	

^Qf_{max} ≡ maximum count frequency

t_{PLH} ≡ propagation delay time, low-to-high-level output

t_{PHL} ≡ propagation delay time, high-to-low-level output



TTL DEVICES

TTL DEVICES

3

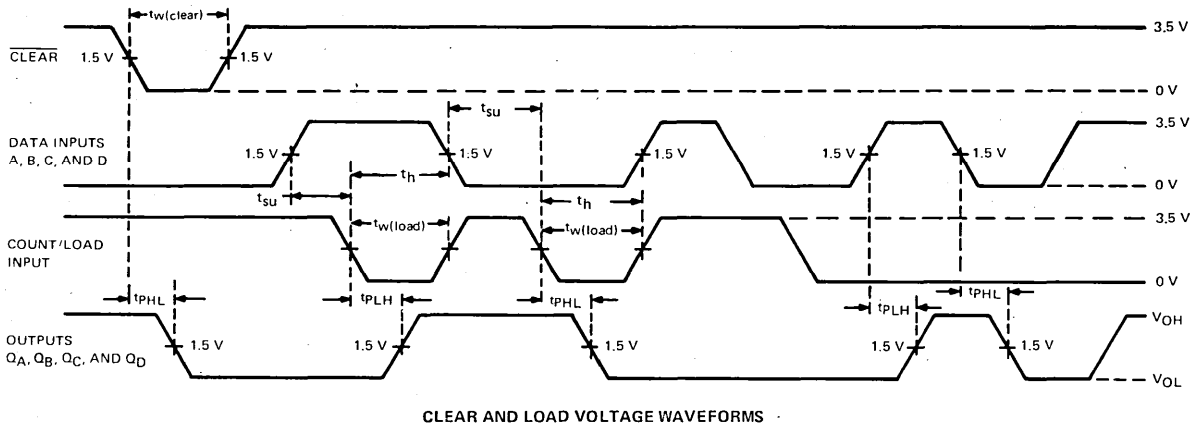
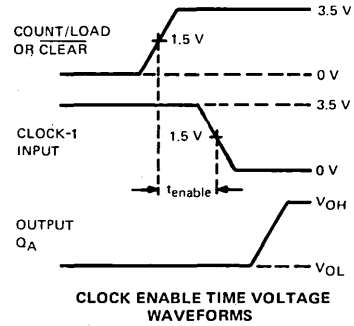
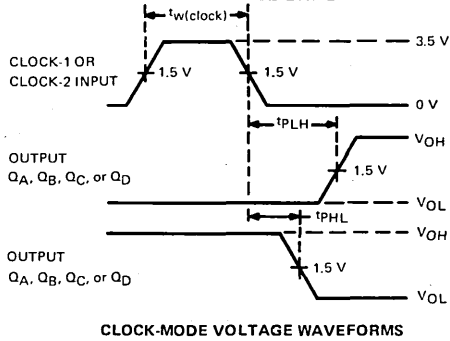
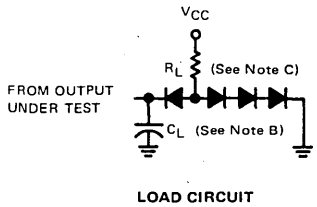

FIGURE 1

- NOTES: A. The input pulse is supplied by a generator having the following characteristics: PRR \leq 1 MHz, duty cycle \leq 50%, $t_f <$ 5 ns, and unless specified, $t_f <$ 5 ns. When testing f_{max} , vary PRR.
- B. C_L includes probe and jig capacitance.
- C. All diodes are 1N3064 or equivalent.
- D. Unless otherwise specified, Q_A is connected to clock 2.

TYPES SN54178, SN54179, SN74178, SN74179 4-BIT PARALLEL-ACCESS SHIFT REGISTERS

DECEMBER 1972—REVISED DECEMBER 1983

- Typical Maximum Clock Frequency . . . 39 MHz
- Three Operating Modes:
Synchronous Parallel Load
Right Shift
Hold (Do Nothing)
- Negative-Edge-Triggered Clocking
- D-C Coupling Simplifies System Designs

description

These shift registers utilize fully d-c coupled storage elements and feature synchronous parallel inputs and parallel outputs. The SN54179/SN74179 has a direct clear line and complementary output from the D flip-flop, thereby differing from the SN54178/SN74178.

Parallel loading is accomplished by taking the shift input low, applying the four bits of data, and taking the load input high. The data is loaded into the associated flip-flop synchronously and appears at the outputs after a high-to-low transition of the clock. During loading, serial data flow is inhibited.

Shift right is also accomplished on the falling edge of the clock pulse when the shift input is high regardless of the level of the load input. Serial data for this mode is entered at the serial data input.

When both the shift and load inputs are low, clocking of the register can continue; however, data appearing at each output is fed back to the flip-flop input creating a mode in which the data is held unchanged. Thus, the system clock may be left free-running without changing the contents of the register.

SN54178 . . . J OR W PACKAGE
SN74178 . . . J OR N PACKAGE
(TOP VIEW)

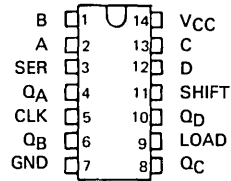

SN54179 . . . J OR W PACKAGE
SN74179 . . . J OR N PACKAGE
(TOP VIEW)

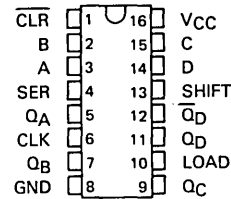

'178, '179†
FUNCTION TABLE

INPUTS					OUTPUTS								
CLEAR†	SHIFT	LOAD	CLOCK	SERIAL	PARALLEL				QA	QB	QC	QD	QD†
					A	B	C	D					
L	X	X	X	X	X	X	X	X	L	L	L	L	H
H	X	X	H	X	X	X	X	X	QA0	QB0	QC0	QD0	QD0
H	L	L	↓	X	X	X	X	X	QA0	QB0	QC0	QD0	QD0
H	L	H	↓	X	a	b	c	d	a	b	c	d	d
H	H	X	↓	H	X	X	X	X	H	QA _n	QB _n	QC _n	QC _n
H	H	X	↓	L	X	X	X	X	L	QA _n	QB _n	QC _n	QC _n

† The columns for clear, Q_D, and the top line of the table apply for the '179 only.

H = high level (steady state), L = low level (steady state)

X = irrelevant (any input, including transitions)

↓ = transition from high to low level

a, b, c, d = the level of steady-state input at inputs A, B, C, or D, respectively.

QA0, QB0, QC0, QD0 = the level of QA, QB, QC, or QD, respectively, before the indicated steady-state input conditions were established.

QA_n, QB_n, QC_n = the level of QA, QB, or QC, respectively, before the most-recent ↓ transition of the clock.

PRODUCTION DATA

This document contains information current as of publication date. Products conform to specifications per the terms of Texas Instruments standard warranty. Production processing does not necessarily include testing of all parameters.

**TEXAS
INSTRUMENTS**

POST OFFICE BOX 225012 • DALLAS, TEXAS 75265

3

TTL DEVICES

TYPES SN54178, SN54179, SN74178, SN74179 4-BIT PARALLEL-ACCESS SHIFT REGISTERS

logic diagram

(178) (179)

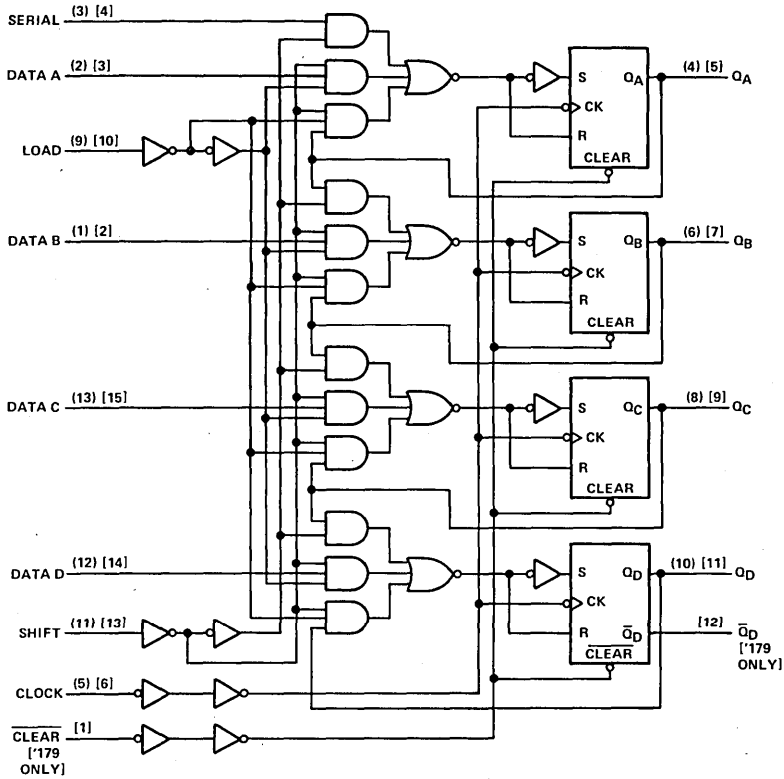

Pin numbers shown on logic notation are for J or N packages.

3 TTL DEVICES

schematics of inputs and outputs

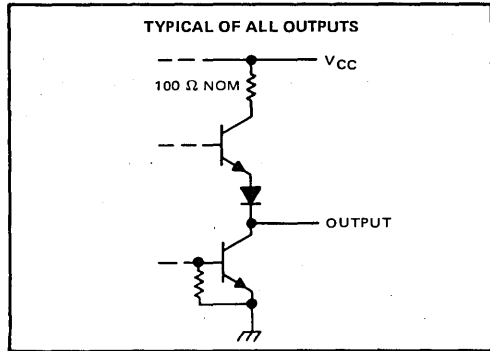
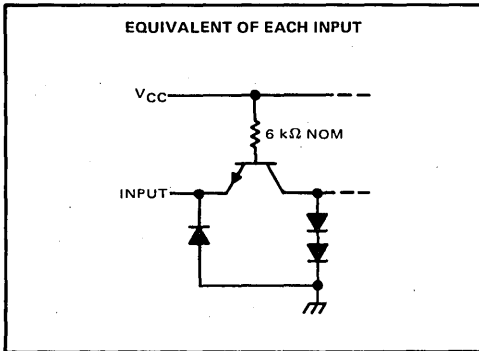

TYPES SN54178, SN54179, SN74178, SN74179 4-BIT PARALLEL-ACCESS SHIFT REGISTERS

absolute maximum ratings over operating free-air temperature range (unless otherwise noted)

Supply voltage, V_{CC} (see Note 1)	7 V
Input voltage	5.5 V
Operating free-air temperature range: SN54178, SN54179 Circuits	-55°C to 125°C
SN74178, SN74179 Circuits	0°C to 70°C
Storage temperature range	-65°C to 150°C

NOTE 1: Voltage values are with respect to network ground terminal.

recommended operating conditions

	SN54178, SN54179			SN74178, SN74179			UNIT		
	MIN	NOM	MAX	MIN	NOM	MAX			
Supply voltage, V_{CC}	4.5	5	5.5	4.75	5	5.25	V		
High-level output current, I_{OH}	-800			-800			μ A		
Low-level output current, I_{OL}	16			16			mA		
Clock frequency, f_{clock}	0			25			MHz		
Width of clock or clear pulse, t_w (see Figure 1)	20			20			ns		
Setup time, t_{SU} (see Figure 1)	Shift (H or L) or load			35			ns		
	Data			30					
	Clear-inactive-state (SN54179 and SN74179)			15					
Hold time at any input, t_H	5			5			ns		
Operating free-air temperature, T_A	-55			125			0	70	°C

electrical characteristics over recommended operating free-air temperature range (unless otherwise noted)

PARAMETER	TEST CONDITIONS†	SN54178, SN54179			SN74178, SN74179			UNIT
		MIN	TYP‡	MAX	MIN	TYP‡	MAX	
V_{IH} High-level input voltage		2			2			V
V_{IL} Low-level input voltage		0.8			0.8			V
V_{IK} Input clamp voltage	$V_{CC} = \text{MIN}, I_I = -12 \text{ mA}$	-1.5			-1.5			V
V_{OH} High-level output voltage	$V_{CC} = \text{MIN}, V_{IH} = 2 \text{ V}, V_{IL} = 0.8 \text{ V}, I_{OH} = -800 \mu\text{A}$	2.4	3.4		2.4	3.4		V
V_{OL} Low-level output voltage	$V_{CC} = \text{MIN}, V_{IH} = 2 \text{ V}, V_{IL} = 0.8 \text{ V}, I_{OL} = 16 \text{ mA}$		0.2	0.4		0.2	0.4	V
I_I Input current at maximum input voltage	$V_{CC} = \text{MAX}, V_I = 5.5 \text{ V}$	1			1			mA
I_{IH} High-level input current	$V_{CC} = \text{MAX}, V_I = 2.4 \text{ V}$	40			40			μ A
I_{IL} Low-level input current	$V_{CC} = \text{MAX}, V_I = 0.4 \text{ V}$	-1.6			-1.6			mA
I_{OS} Short-circuit output current§	$V_{CC} = \text{MAX}$	-20	-57		-18	-57		mA
I_{CC} Supply current	$V_{CC} = \text{MAX}, \text{ See Note 2}$	46	70		46	75		mA

† For conditions shown as MIN or MAX, use the appropriate value specified under recommended operating conditions for the applicable device type.

‡ All typical values are at $V_{CC} = 5 \text{ V}, T_A = 25^\circ\text{C}$.

§ Not more than one output should be shorted at a time.

NOTE 2: I_{CC} is measured as follows:

- 4.5 V is applied to serial inputs, load, shift, and clear,
- Parallel inputs A through D are grounded.
- 4.5 V is momentarily applied to clock which is then grounded.

3

TTL DEVICES

TYPES SN54178, SN54179, SN74178, SN74179

4-BIT PARALLEL-ACCESS SHIFT REGISTERS

switching characteristics, $V_{CC} = 5\text{ V}$, $T_A = 25^\circ\text{C}$

PARAMETER [†]	FROM (INPUT)	TO (OUTPUT)	TEST CONDITIONS	MIN	TYP	MAX	UNIT
f_{\max}			$C_L = 15\text{ pF}$, $R_L = 400\ \Omega$, See Figure 1	25	39		MHz
t_{PLH}	Clear	\bar{Q}_D		15	23		ns
t_{PHL}		Q_A, Q_B, Q_C, Q_D		24	36		
t_{PLH}	Clock	Any output		17	26		ns
t_{PHL}				23	35		

[†] f_{\max} ≡ Maximum clock frequency

t_{PHL} ≡ Propagation delay time, high-to-low-level output

t_{PLH} ≡ Propagation delay time, low-to-high-level output

PARAMETER MEASUREMENT INFORMATION

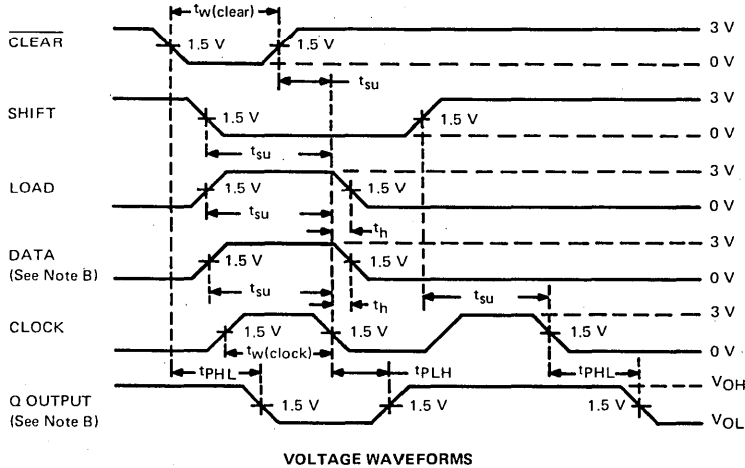
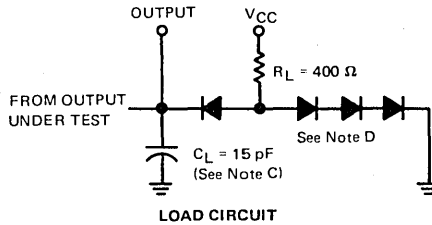

- NOTES: A. Input pulses are supplied by generators having the following characteristics: $t_{TLH} \leq 10\text{ ns}$, $t_{THL} \leq 10\text{ ns}$, $PRR \leq 1\text{ MHz}$, $Z_{out} \approx 50\ \Omega$.
- B. Data input and Q output are any related pair. Serial and other data inputs are at GND. Serial data input is tested in conjunction with Q_A output in the shift mode.
- C. C_L includes probe and jig capacitance.
- D. All diodes are 1N3064 or equivalent.

FIGURE 1—SWITCHING TIMES

TYPES SN54180, SN74180 9-BIT ODD/EVEN PARITY GENERATORS/CHECKERS

DECEMBER 1972—REVISED DECEMBER 1983

SN54180 . . . J OR W PACKAGE
SN74180 . . . J OR N PACKAGE
(TOP VIEW)

Σ OF H's AT A THRU H	INPUTS		OUTPUTS	
	EVEN	ODD	Σ EVEN	Σ ODD
EVEN	H	L	H	L
ODD	H	L	L	H
EVEN	L	H	L	H
ODD	L	H	H	L
X	H	H	L	L
X	L	L	H	H

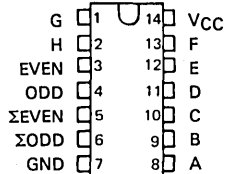

H = high level, L = low level, X = irrelevant

description

These universal, monolithic, 9-bit (8 data bits plus 1 parity bit) parity generators/checkers, utilize familiar Series 54/74 TTL circuitry and feature odd/even outputs and control inputs to facilitate operation in either odd or even-parity applications. Depending on whether even or odd parity is being generated or checked, the even or odd inputs can be utilized as the parity or 9th-bit input. The word-length capability is easily expanded by cascading.

The SN54180/SN74180 are fully compatible with other TTL or DTL circuits. Input buffers are provided so that each data input represents only one normalized series 54/74 load. A full fan-out to 10 normalized series 54/74 loads is available from each of the outputs at a low logic level. A fan-out to 20 normalized loads is provided at a high logic level to facilitate the connection of unused inputs to used inputs. Typical power dissipation is 170 mW.

The SN54180 is characterized for operation over the full military temperature range of -55°C to 125°C ; and the SN74180 is characterized for operation from 0°C to 70°C .

absolute maximum ratings over operating free-air temperature range (unless otherwise noted)

Supply voltage, V_{CC} (see Note 1)	7 V
Input voltage	5.5 V
Operating free-air temperature range: SN54180 Circuits	-55°C to 125°C
SN74180 Circuits	0°C to 70°C
Storage temperature range	-65°C to 150°C

NOTE 1: Voltage values are with respect to network ground terminal.

recommended operating conditions

	SN54180			SN74180			UNIT
	MIN	NOM	MAX	MIN	NOM	MAX	
Supply voltage, V_{CC}	4.5	5	5.5	4.75	5	5.25	V
High-level output current, I_{OH}			-800			-800	μA
Low-level output current, I_{OL}			16			16	mA
Operating free-air temperature, T_A	-55		125	0		70	$^{\circ}\text{C}$

3
TTL DEVICES

TYPES SN54180, SN74180

9-BIT ODD/EVEN PARITY GENERATORS/CHECKERS

electrical characteristics over recommended operating free-air temperature range (unless otherwise noted)

PARAMETER	TEST CONDITIONS†	SN54180			SN74180			UNIT
		MIN	TYP‡	MAX	MIN	TYP‡	MAX	
V _{IH} High-level input voltage		2			2			V
V _{IL} Low-level input voltage		0.8			0.8			V
V _{IK} Input clamp voltage	V _{CC} = MIN, I _I = -12 mA	-1.5			-1.5			V
V _{OH} High-level output voltage	V _{CC} = MIN, V _{IH} = 2 V, V _{IL} = 0.8 V, I _{OH} = -800 μA	2.4	3.3		2.4	3.3		V
V _{OL} Low-level output voltage	V _{CC} = MIN, V _{IH} = 2 V, V _{IL} = 0.8 V, I _{OL} = 16 mA		0.2	0.4		0.2	0.4	V
I _I Input current at maximum input voltage	V _{CC} = MAX, V _I = 5.5 V	1			1			mA
I _{IH} High-level input current	Any data input	40			40			μA
	Even or odd input	80			80			
I _{IL} Low-level input current	Any data input	-1.6			-1.6			mA
	Even or odd input	-3.2			-3.2			
I _{OS} Short-circuit output current §	V _{CC} = MAX	-20	-55		-18	-55		mA
I _{CC} Supply current	V _{CC} = MAX, See Note 2	34	49		34	56		mA

NOTE 2: I_{CC} is measured with even and odd inputs at 4.5 V, all other inputs and outputs open.

† For conditions shown as MIN or MAX, use the appropriate value specified under recommended operating conditions for the applicable type.

‡ All typical values are at V_{CC} = 5 V, T_A = 25°C.

§ Not more than one output should be shorted at a time.

switching characteristics, V_{CC} = 5 V, T_A = 25°C

PARAMETER¶	FROM (INPUT)	TO (OUTPUT)	TEST CONDITIONS	MIN	TYP	MAX	UNIT
t _{PLH}	Data	Σ Even	C _L = 15 pF, R _L = 400 Ω, Odd input grounded, See Note 3	40	60	ns	
t _{PHL}				45	68		
t _{PLH}	Data	Σ Odd		32	48	ns	
t _{PHL}				25	38		
t _{PLH}	Data	Σ Even		C _L = 15 pF, R _L = 400 Ω, Even input grounded, See Note 3	32	48	ns
t _{PHL}					25	38	
t _{PLH}	Data	Σ Odd	40		60	ns	
t _{PHL}			45		68		
t _{PLH}	Even or Odd	Σ Even or Σ Odd	C _L = 15 pF, R _L = 400 Ω, See Note 3		13	20	ns
t _{PHL}					7	10	

NOTE 3: See General Information Section for load circuits and voltage waveforms.

TYPES SN54180, SN74180 9-BIT ODD/EVEN PARITY GENERATORS/CHECKERS

schematics of inputs and outputs

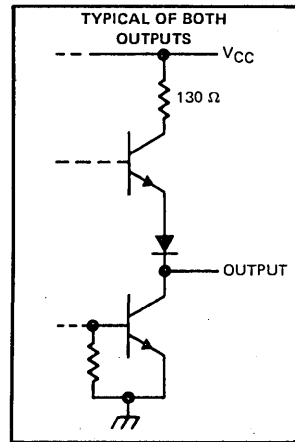
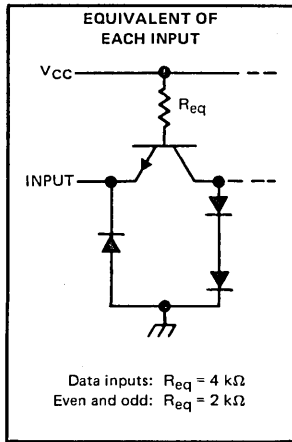

logic diagram

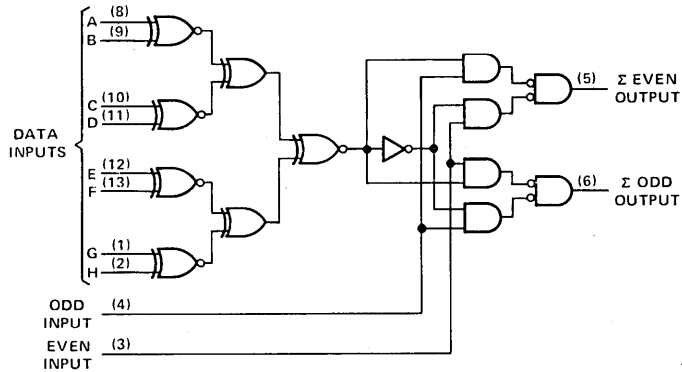

Pin numbers shown on logic notation are for J or N packages.

**TYPES SN54181, SN54LS181, SN54S181,
SN74181, SN74LS181, SN74S181**
ARITHMETIC LOGIC UNITS/FUNCTION GENERATORS
 DECEMBER 1972 — REVISED DECEMBER 1983

- Full Look-Ahead for High-Speed Operations on Long Words
- Input Clamping Diodes Minimize Transmission-Line Effects
- Darlington Outputs Reduce Turn-Off Time
- Arithmetic Operating Modes:
 - Addition
 - Subtraction
 - Shift Operand A One Position
 - Magnitude Comparison
 - Plus Twelve Other Arithmetic Operations
- Logic Function Modes:
 - Exclusive-OR
 - Comparator
 - AND, NAND, OR, NOR
 - Plus Ten Other Logic Operations

SN54181, SN54LS181, SN54S181 ... J OR W PACKAGE
 SN74181 ... J OR N PACKAGE
 SN74LS181, SN74S181 ... DW, J OR N PACKAGE

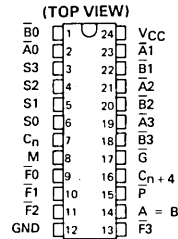

SN54LS181, SN54S181 ... FK PACKAGE
 SN74LS181, SN74S181 ... FN PACKAGE

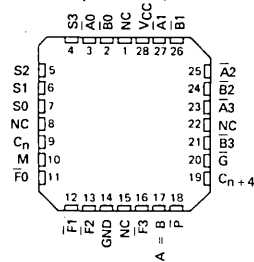

NC - No internal connection

TYPICAL ADDITION TIMES

NUMBER OF BITS	ADDITION TIMES			PACKAGE COUNT		CARRY METHOD BETWEEN ALU's
	USING '181 AND '182	USING 'LS181 AND '182	USING 'S181 AND 'S182	ARITHMETIC/ LOGIC UNITS	LOOK-AHEAD CARRY GENERATORS	
1 to 4	24 ns	24 ns	11 ns	1		NONE
5 to 8	36 ns	40 ns	18 ns	2		RIPPLE
9 to 16	36 ns	44 ns	19 ns	3 or 4	1	FULL LOOK-AHEAD
17 to 64	60 ns	68 ns	28 ns	5 to 16	2 to 5	FULL LOOK-AHEAD

description

The '181, 'LS181, and 'S181 are arithmetic logic units (ALU)/function generators that have a complexity of 75 equivalent gates on a monolithic chip. These circuits perform 16 binary arithmetic operations on two 4-bit words as shown in Tables 1 and 2. These operations are selected by the four function-select lines (S0, S1, S2, S3) and include addition, subtraction, decrement, and straight transfer. When performing arithmetic manipulations, the internal carries must be enabled by applying a low-level voltage to the mode control input (M). A full carry look-ahead scheme is made available in these devices for fast, simultaneous carry generation by means of two cascade-outputs (pins 15 and 17) for the four bits in the package. When used in conjunction with the SN54182, SN54S182, SN74182, or SN74S182, full carry look-ahead circuits, high-speed arithmetic operations can be performed. The typical addition times shown above illustrate the little additional time required for addition of longer words when full carry look-ahead is employed. The method of cascading '182 or 'S182 circuits with these ALU's to provide multi-level full carry look-ahead is illustrated under typical applications data for the '182 and 'S182.

If high speed is not of importance, a ripple-carry input (C_n) and a ripple-carry output (C_{n+4}) are available. However, the ripple-carry delay has also been minimized so that arithmetic manipulations for small word lengths can be performed without external circuitry.

PRODUCTION DATA
 This document contains information current as of publication date. Products conform to specifications per the terms of Texas Instruments standard warranty. Production processing does not necessarily include testing of all parameters.



POST OFFICE BOX 225012 • DALLAS, TEXAS 75265

TYPES SN54181, SN54LS181, SN54S181, SN74181, SN74LS181, SN74S181 ARITHMETIC LOGIC UNITS/FUNCTION GENERATORS

description (continued)

The '181, 'LS181, and 'S181 will accommodate active-high or active-low data if the pin designations are interpreted as follows:

PIN NUMBER	2	1	23	22	21	20	19	18	9	10	11	13	7	16	15	17
Active-low data (Table 1)	\bar{A}_0	\bar{B}_0	\bar{A}_1	\bar{B}_1	\bar{A}_2	\bar{B}_2	\bar{A}_3	\bar{B}_3	F ₀	F ₁	F ₂	F ₃	C _n	C _{n+4}	P	\bar{G}
Active-high data (Table 2)	A ₀	B ₀	A ₁	B ₁	A ₂	B ₂	A ₃	B ₃	F ₀	F ₁	F ₂	F ₃	\bar{C}_n	\bar{C}_{n+4}	X	Y

Subtraction is accomplished by 1's complement addition where the 1's complement of the subtrahend is generated internally. The resultant output is $A-B-1$, which requires an end-around or forced carry to provide $A-B$.

The '181, 'LS181, or 'S181 can also be utilized as a comparator. The $A = B$ output is internally decoded from the function outputs (F₀, F₁, F₂, F₃) so that when two words of equal magnitude are applied at the A and B inputs, it will assume a high level to indicate equality ($A = B$). The ALU must be in the subtract mode with $C_n = H$ when performing this comparison. The $A = B$ output is open-collector so that it can be wire-AND connected to give a comparison for more than four bits. The carry output (C_{n+4}) can also be used to supply relative magnitude information. Again, the ALU must be placed in the subtract mode by placing the function select inputs S₃, S₂, S₁, S₀ at L, H, H, L, respectively.

INPUT C _n	OUTPUT C _{n+4}	ACTIVE-LOW DATA (FIGURE 1)	ACTIVE-HIGH DATA (FIGURE 2)
H	H	$A > B$	$A < B$
H	L	$A < B$	$A > B$
L	H	$A > B$	$A < B$
L	L	$A < B$	$A > B$

These circuits have been designed to not only incorporate all of the designer's requirements for arithmetic operations, but also to provide 16 possible functions of two Boolean variables without the use of external circuitry. These logic functions are selected by use of the four function-select inputs (S₀, S₁, S₂, S₃) with the mode-control input (M) at a high level to disable the internal carry. The 16 logic functions are detailed in Tables 1 and 2 and include exclusive-OR, NAND, AND, NOR, and OR functions.

Series 54, 54LS, and 54S devices are characterized for operation over the full military temperature range of -55°C to 125°C ; Series 74, 74LS, and 74S devices are characterized for operation from 0°C to 70°C .

signal designations

The '181, 'LS181, and 'S181 together with the '182 and 'S182 can be used with the signal designations of either Figure 1 or Figure 2. The inversion indicators (O) and the bars over the terminal letter symbols (e.g., \bar{C}) each indicate that the associated input or output is active with respect to the selected function of the device when that input or output is low. That is, a low at \bar{C} means "do carry" while a high means "do not carry".

The logic functions and arithmetic operations obtained with signal designations of Figure 1 are given in Table 1; those obtained with signal designations of Figure 2 are given in Table 2.

TYPES SN54181, SN54LS181, SN54S181,
SN74181, SN74LS181, SN74S181
ARITHMETIC LOGIC UNITS/FUNCTION GENERATORS

signal designations (continued)

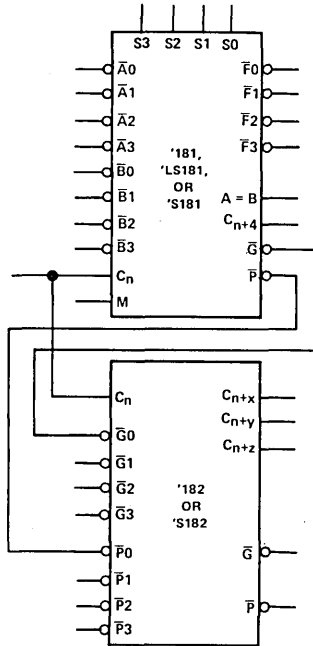

FIGURE 1

TABLE 1

SELECTION				ACTIVE-LOW DATA		
				M = H LOGIC FUNCTIONS	M = L: ARITHMETIC OPERATIONS	
S3	S2	S1	S0		Cn = L (no carry)	Cn = H (with carry)
L	L	L	L	$F = \bar{A}$	$F = A \text{ MINUS } 1$	$F = A$
L	L	L	H	$F = \overline{AB}$	$F = AB \text{ MINUS } 1$	$F = AB$
L	L	H	L	$F = \bar{A} + B$	$F = \overline{AB} \text{ MINUS } 1$	$F = \overline{AB}$
L	L	H	H	$F = 1$	$F = \text{MINUS } 1 \text{ (2's COMP)}$	$F = \text{ZERO}$
L	H	L	L	$F = \overline{A + B}$	$F = A \text{ PLUS } (A + \bar{B})$	$F = A \text{ PLUS } (A + \bar{B}) \text{ PLUS } 1$
L	H	L	H	$F = \bar{B}$	$F = AB \text{ PLUS } (A + \bar{B})$	$F = AB \text{ PLUS } (A + \bar{B}) \text{ PLUS } 1$
L	H	H	L	$F = A \oplus B$	$F = A \text{ MINUS } B \text{ MINUS } 1$	$F = A \text{ MINUS } B$
L	H	H	H	$F = A + \bar{B}$	$F = A + \bar{B}$	$F = (A + \bar{B}) \text{ PLUS } 1$
H	L	L	L	$F = \overline{AB}$	$F = A \text{ PLUS } (A + B)$	$F = A \text{ PLUS } (A + B) \text{ PLUS } 1$
H	L	L	H	$F = A \oplus B$	$F = A \text{ PLUS } B$	$F = A \text{ PLUS } B \text{ PLUS } 1$
H	L	H	L	$F = B$	$F = \overline{AB} \text{ PLUS } (A + B)$	$F = \overline{AB} \text{ PLUS } (A + B) \text{ PLUS } 1$
H	L	H	H	$F = A + B$	$F = (A + B)$	$F = (A + B) \text{ PLUS } 1$
H	H	L	L	$F = 0$	$F = A$	$F = A \text{ PLUS } A \text{ PLUS } 1$
H	H	L	H	$F = \overline{AB}$	$F = AB \text{ PLUS } A$	$F = AB \text{ PLUS } A \text{ PLUS } 1$
H	H	H	L	$F = AB$	$F = \overline{AB} \text{ PLUS } A$	$F = \overline{AB} \text{ PLUS } A \text{ PLUS } 1$
H	H	H	H	$F = A$	$F = A$	$F = A \text{ PLUS } 1$

TYPES SN54181, SN54LS181, SN54S181,
 SN74181, SN74LS181, SN74S181
 ARITHMETIC LOGIC UNITS/FUNCTION GENERATORS

signal designations (continued)

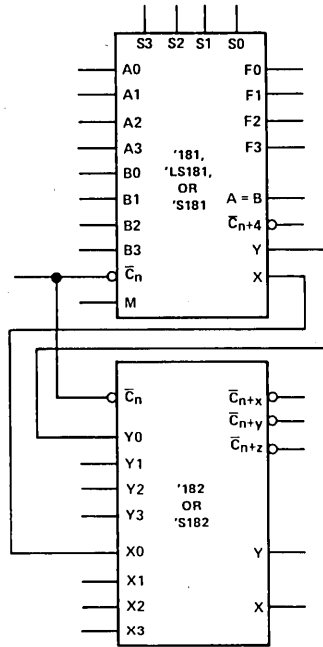

FIGURE 2

TABLE 2

SELECTION				ACTIVE-HIGH DATA		
				M = H LOGIC FUNCTIONS	M = L: ARITHMETIC OPERATIONS	
S3	S2	S1	S0		C _n = H (no carry)	C _n = L (with carry)
L	L	L	L	$F = \bar{A}$	$F = A$	$F = A \text{ PLUS } 1$
L	L	L	H	$F = \overline{A+B}$	$F = A + B$	$F = (A + B) \text{ PLUS } 1$
L	L	H	L	$F = \overline{AB}$	$F = A + \bar{B}$	$F = (A + \bar{B}) \text{ PLUS } 1$
L	L	H	H	$F = 0$	$F = \text{MINUS } 1 \text{ (2's COMPL)}$	$F = \text{ZERO}$
L	H	L	L	$F = \overline{AB}$	$F = A \text{ PLUS } \overline{AB}$	$F = A \text{ PLUS } \overline{AB} \text{ PLUS } 1$
L	H	L	H	$F = \bar{B}$	$F = (A + B) \text{ PLUS } \overline{AB}$	$F = (A + B) \text{ PLUS } \overline{AB} \text{ PLUS } 1$
L	H	H	L	$F = A \oplus B$	$F = \overline{A \text{ MINUS } B \text{ MINUS } 1}$	$F = A \text{ MINUS } B$
L	H	H	H	$F = \overline{AB}$	$F = \overline{AB} \text{ MINUS } 1$	$F = \overline{AB}$
H	L	L	L	$F = \overline{A+B}$	$F = A \text{ PLUS } AB$	$F = A \text{ PLUS } AB \text{ PLUS } 1$
H	L	L	H	$F = A \oplus \overline{B}$	$F = A \text{ PLUS } B$	$F = A \text{ PLUS } B \text{ PLUS } 1$
H	L	H	L	$F = B$	$F = (A + \bar{B}) \text{ PLUS } AB$	$F = (A + \bar{B}) \text{ PLUS } AB \text{ PLUS } 1$
H	L	H	H	$F = AB$	$F = AB \text{ MINUS } 1$	$F = AB$
H	H	L	L	$F = 1$	$F = A$	$F = A \text{ PLUS } A \text{ PLUS } 1$
H	H	L	H	$F = A + \bar{B}$	$F = (A + B) \text{ PLUS } A$	$F = (A + B) \text{ PLUS } A \text{ PLUS } 1$
H	H	H	L	$F = A + B$	$F = (A + \bar{B}) \text{ PLUS } A$	$F = (A + \bar{B}) \text{ PLUS } A \text{ PLUS } 1$
H	H	H	H	$F = A$	$F = A \text{ MINUS } 1$	$F = A$

TYPES SN54181, SN54LS181, SN54S181, SN74181, SN74LS181, SN74S181
 ARITHMETIC LOGIC UNITS/FUNCTION GENERATORS

logic diagram

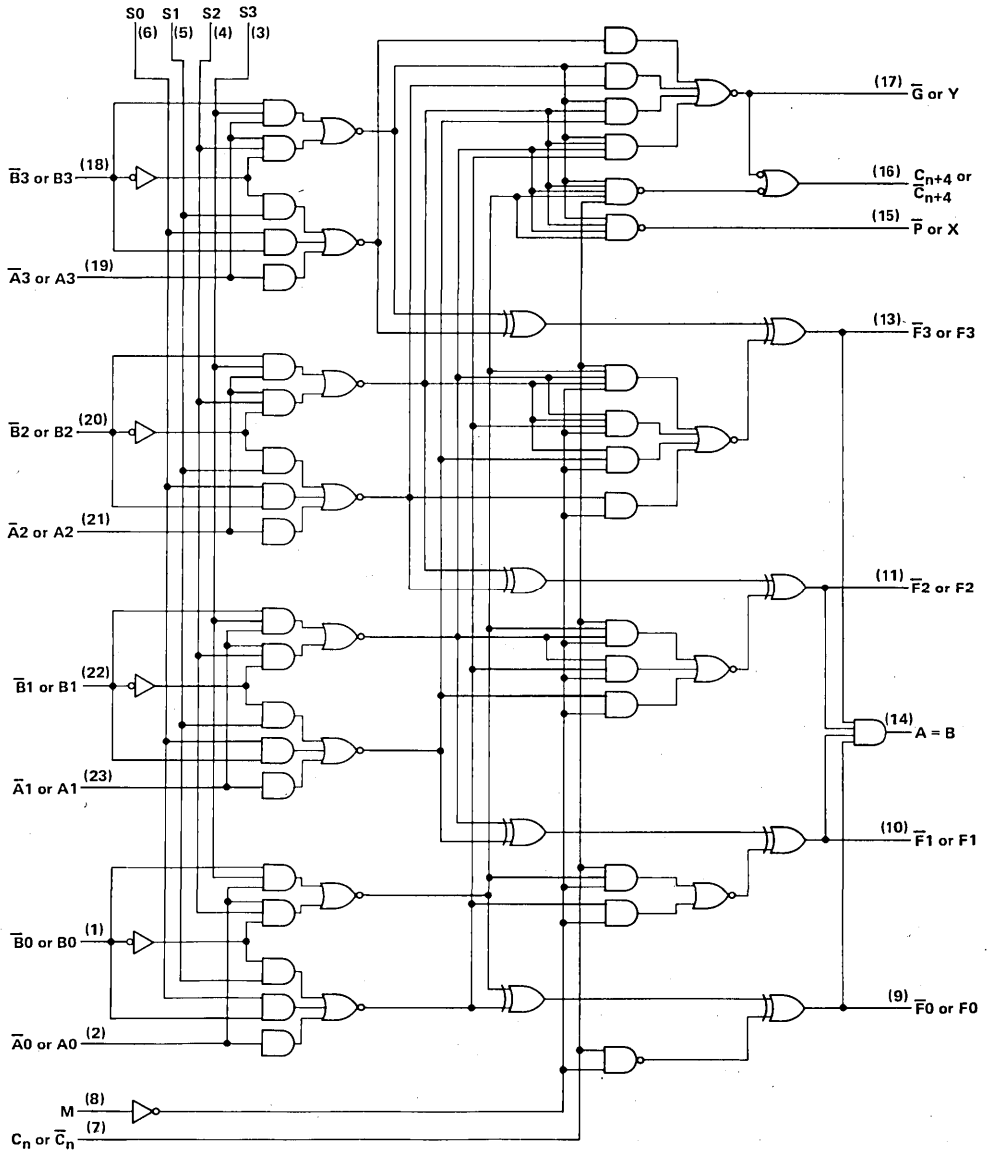

Pin numbers shown on logic notation are for DW, J or N packages.

3
 TTL DEVICES

TYPES SN54181, SN74181 ARITHMETIC LOGIC UNITS/FUNCTION GENERATORS

absolute maximum ratings over operating free-air temperature range (unless otherwise noted)

Supply voltage, V_{CC} (see Note 1)	7 V
Input voltage	5.5 V
Interemitter voltage (see Note 2)	5.5 V
Operating free-air temperature range: SN54181	-55°C to 125°C
SN74181	0°C to 70°C
Storage temperature range	-65°C to 150°C

- NOTES: 1. Voltage values, except interemitter voltage, are with respect to network ground terminal.
 2. This is the voltage between two emitters of a multiple-emitter transistor. For this circuit, this rating applies to each \bar{A} input in conjunction with inputs S2 or S3, and to each \bar{B} input in conjunction with inputs S0 or S3.

recommended operating conditions

	SN54181			SN74181			UNIT
	MIN	NOM	MAX	MIN	NOM	MAX	
Supply voltage, V_{CC}	4.5	5	5.5	4.75	5	5.25	V
High-level output current, I_{OH} (All outputs except A = B)			-800			-800	μ A
Low-level output current, I_{OL}			16			16	mA
Operating free-air temperature, T_A	-55		125	0		70	°C

electrical characteristics over recommended operating free-air temperature range (unless otherwise noted)

PARAMETER		TEST CONDITIONS†	SN54181			SN74181			UNIT	
			MIN	TYP‡	MAX	MIN	TYP‡	MAX		
V_{IH}	High-level input voltage		2			2			V	
V_{IL}	Low-level input voltage				0.8			0.8	V	
V_{IK}	Input clamp voltage	$V_{CC} = \text{MIN}, I_I = -12 \text{ mA}$			-1.5			-1.5	V	
V_{OH}	High-level output voltage, any output except A = B	$V_{CC} = \text{MIN}, V_{IH} = 2 \text{ V}, V_{IL} = 0.8 \text{ V}, I_{OH} = -800 \mu\text{A}$	2.4	3.4		2.4	3.4		V	
I_{OH}	High-level output current, A = B output only	$V_{CC} = \text{MIN}, V_{IH} = 2 \text{ V}, V_{IL} = 0.8 \text{ V}, V_{OH} = 5.5 \text{ V}$			250			250	μ A	
V_{OL}	Low-level output voltage	$V_{CC} = \text{MIN}, V_{IH} = 2 \text{ V}, V_{IL} = 0.8 \text{ V}, I_{OL} = 16 \text{ mA}$		0.2	0.4		0.2	0.4	V	
I_I	Input current at maximum input voltage	$V_{CC} = \text{MAX}, V_I = 5.5 \text{ V}$			1			1	mA	
I_{IH}	High-level input current	Mode input			40			40	μ A	
		Any \bar{A} or \bar{B} input			120			120		
		Any S input			160			160		
		Carry input			200			200		
I_{IL}	Low-level input current	Mode input			-1.6			-1.6	mA	
		Any \bar{A} or \bar{B} input			-4.8			-4.8		
		Any S input			-6.4			-6.4		
		Carry input			-8			-8		
I_{OS}	Short-circuit output current, any output except A = B§	$V_{CC} = \text{MAX}$	-20		-55	-18		-57	mA	
I_{CC}	Supply current	$V_{CC} = \text{MAX},$ See Note 3		Condition A	88	127		88	140	mA
				Condition B	94	135		94	150	mA

†For conditions shown as MIN or MAX, use the appropriate value specified under recommended operating conditions.

‡All typical values are at $V_{CC} = 5 \text{ V}, T_A = 25^\circ\text{C}$.

§Not more than one output should be shorted at a time.

NOTE 3: With outputs open, I_{CC} is measured for the following conditions:

A. S0 through S3, M, and \bar{A} inputs are at 4.5 V, all other inputs are grounded.

B. S0 through S3 and M are at 4.5 V, all other inputs are grounded.

TTL DEVICES

TYPES SN54181, SN74181 ARITHMETIC LOGIC UNITS/FUNCTION GENERATORS

switching characteristics, $V_{CC} = 5\text{ V}$, $T_A = 25^\circ\text{C}$ ($C_L = 15\text{ pF}$, $R_L = 400\ \Omega$, see note 4)

PARAMETER [†]	FROM (INPUT)	TO (OUTPUT)	TEST CONDITIONS	MIN	TYP	MAX	UNIT
t_{PLH}	C_n	C_{n+4}			12	18	ns
t_{PHL}					13	19	
t_{PLH}	Any \bar{A} or \bar{B}	C_{n+4}	$M = 0\text{ V}$, $S_0 = S_3 = 4.5\text{ V}$, $S_1 = S_2 = 0\text{ V}$ (SUM mode)		28	43	ns
t_{PHL}					27	41	
t_{PLH}	Any \bar{A} or \bar{B}	C_{n+4}	$M = 0\text{ V}$, $S_0 = S_3 = 0\text{ V}$, $S_1 = S_2 = 4.5\text{ V}$ (DIFF mode)		35	50	ns
t_{PHL}					33	50	
t_{PLH}	C_n	Any \bar{F}	$M = 0\text{ V}$ (SUM or DIFF mode)		13	19	ns
t_{PHL}					12	18	
t_{PLH}	Any \bar{A} or \bar{B}	\bar{G}	$M = 0\text{ V}$, $S_0 = S_3 = 4.5\text{ V}$, $S_1 = S_2 = 0\text{ V}$ (SUM mode)		13	19	ns
t_{PHL}					13	19	
t_{PLH}	Any \bar{A} or \bar{B}	\bar{G}	$M = 0\text{ V}$, $S_0 = S_3 = 0\text{ V}$, $S_1 = S_2 = 4.5\text{ V}$ (DIFF mode)		17	25	ns
t_{PHL}					17	25	
t_{PLH}	Any \bar{A} or \bar{B}	\bar{P}	$M = 0\text{ V}$, $S_0 = S_3 = 4.5\text{ V}$, $S_1 = S_2 = 0\text{ V}$ (SUM mode)		13	19	ns
t_{PHL}					17	25	
t_{PLH}	Any \bar{A} or \bar{B}	\bar{P}	$M = 0\text{ V}$, $S_0 = S_3 = 0\text{ V}$, $S_1 = S_2 = 4.5\text{ V}$ (DIFF mode)		17	25	ns
t_{PHL}					17	25	
t_{PLH}	\bar{A}_i or \bar{B}_i	\bar{F}_i	$M = 0\text{ V}$, $S_0 = S_3 = 4.5\text{ V}$, $S_1 = S_2 = 0\text{ V}$ (SUM mode)		28	42	ns
t_{PHL}					21	32	
t_{PLH}	\bar{A}_i or \bar{B}_i	\bar{F}_i	$M = 0\text{ V}$, $S_0 = S_3 = 0\text{ V}$, $S_1 = S_2 = 4.5\text{ V}$ (DIFF mode)		32	48	ns
t_{PHL}					23	34	
t_{PLH}	\bar{A}_i or \bar{B}_i	\bar{F}_i	$M = 4.5\text{ V}$ (logic mode)		32	48	ns
t_{PHL}					23	34	
t_{PLH}	Any \bar{A} or \bar{B}	$A = B$	$M = 0\text{ V}$, $S_0 = S_3 = 0\text{ V}$, $S_1 = S_2 = 4.5\text{ V}$ (DIFF mode)		35	50	ns
t_{PHL}					32	48	

[†] t_{PLH} = propagation delay time, low-to-high-level output

t_{PHL} = propagation delay time, high-to-low-level output

NOTE 4: See General Information Section for load circuits and voltage waveforms.

schematics of inputs and outputs

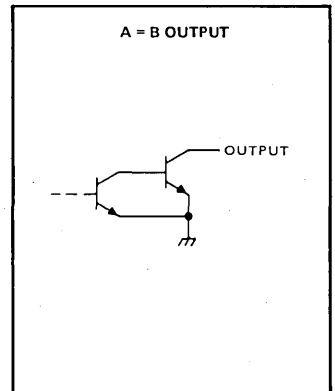
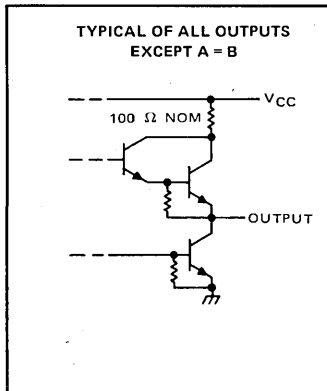
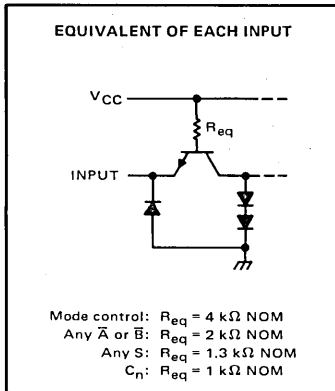

3

TTL DEVICES

TYPES SN54LS181, SN74LS181 ARITHMETIC LOGIC UNITS/FUNCTION GENERATORS

absolute maximum ratings over recommended operating free-air temperature range (unless otherwise noted)

Supply voltage, V_{CC} (see Note 1)	7 V
Input voltage	5.5 V
Intermitter voltage (see Note 2)	5.5 V
Operating free-air temperature range: SN54LS181	-55°C to 125°C
SN74LS181	0°C to 70°C
Storage temperature range	-65°C to 150°C

NOTES: 1. Voltage values, except intermitter voltage, are with respect to network ground terminal.

2. This is the voltage between two emitters of a multiple-emitter transistor. For this circuit, this rating applies to each \bar{A} input in conjunction with inputs S2 or S3, and to each \bar{B} input in conjunction with inputs S0 or S3.

recommended operating conditions

	SN54LS181			SN74LS181			UNIT
	MIN	NOM	MAX	MIN	NOM	MAX	
Supply voltage, V_{CC}	4.5	5	5.5	4.75	5	5.25	V
High-level output current, I_{OH} (All outputs except A = B)	-400			-400			μ A
Low-level output current, I_{OL}	4			8			mA
Operating free-air temperature, T_A	-55		125	0		70	°C

electrical characteristics over recommended operating free-air temperature range (unless otherwise noted)

PARAMETER		TEST CONDITIONS†	SN54LS181			SN74LS181			UNIT	
			MIN	TYP‡	MAX	MIN	TYP‡	MAX		
V_{IH}	High-level input voltage		2			2			V	
V_{IL}	Low-level input voltage		0.7			0.8			V	
V_{IK}	Input clamp voltage	$V_{CC} = \text{MIN}, I_I = -18 \text{ mA}$	-1.5			-1.5			V	
V_{OH}	High-level output voltage, any output except A = B	$V_{CC} = \text{MIN}, V_{IH} = 2 \text{ V}, V_{IL} = V_{IL \text{ max}}, I_{OH} = -400 \mu\text{A}$	2.5	3.4		2.7	3.4		V	
I_{OH}	High-level output current, A = B output only	$V_{CC} = \text{MIN}, V_{IH} = 2 \text{ V}, V_{IL} = V_{IL \text{ max}}, V_{OH} = 5.5 \text{ V}$	100			100			μ A	
V_{OL}	Low-level output voltage	All outputs $V_{CC} = \text{MIN}, V_{IH} = 2 \text{ V}, V_{IL} = V_{IL \text{ max}}$	$I_{OL} = 4 \text{ mA}$	0.25	0.4	0.25	0.4		V	
			$I_{OL} = 8 \text{ mA}$			0.35	0.5			
			$I_{OL} = 16 \text{ mA}$	0.47	0.7	0.47	0.7			
			$I_{OL} = 8 \text{ mA}$	0.35	0.6	0.35	0.5			
I_I	Input current at max. input voltage	$V_{CC} = \text{MAX}, V_I = 5.5 \text{ V}$	Mode input	0.1			0.1			mA
			Any \bar{A} or \bar{B} input	0.3			0.3			
			Any S input	0.4			0.4			
			Carry input	0.5			0.5			
I_{IH}	High-level input current	$V_{CC} = \text{MAX}, V_I = 2.7 \text{ V}$	Mode input	20			20			μ A
			Any \bar{A} or \bar{B} input	60			60			
			Any S input	80			80			
			Carry input	100			100			
I_{IL}	Low-level input current	$V_{CC} = \text{MAX}, V_I = 0.4 \text{ V}$	Mode input	-0.4			-0.4			mA
			Any \bar{A} or \bar{B} input	-1.2			-1.2			
			Any S input	-1.6			-1.6			
			Carry input	-2			-2			
I_{OS}	Short-circuit output current, any output except A = B §	$V_{CC} = \text{MAX}$	-6	-40	-5	-42		mA		
I_{CC}	Supply current	$V_{CC} = \text{MAX},$ See Note 3	Condition A	20	32	20	34		mA	
			Condition B	21	35	21	37			

† For conditions shown as MIN or MAX, use the appropriate value specified under recommended operating conditions.

‡ All typical values are at $V_{CC} = 5 \text{ V}, T_A = 25^\circ \text{C}$.

§ Not more than one output should be shorted at a time.

NOTE 3: With outputs open, I_{CC} is measured for the following conditions:

A. S0 through S3, M, and \bar{A} inputs are at 4.5 V, all other inputs are grounded.

B. S0 through S3 and M are at 4.5 V, all other inputs are grounded.

3 TTL DEVICES

TYPES SN54LS181, SN74LS181 ARITHMETIC LOGIC UNITS/FUNCTION GENERATORS

switching characteristics, $V_{CC} = 5\text{ V}$, $T_A = 25^\circ\text{C}$, ($C_L = 15\text{ pF}$, $R_L = 2\text{ k}\Omega$, see note 4)

PARAMETER†	FROM (INPUT)	TO (OUTPUT)	TEST CONDITIONS	MIN	TYP	MAX	UNIT
t_{PLH}	C_n	C_{n+4}		18	27	ns	
t_{PHL}				13	20		
t_{PLH}	Any \bar{A} or \bar{B}	C_{n+4}	$M = 0\text{ V}$, $S_0 = S_3 = 4.5\text{ V}$, $S_1 = S_2 = 0\text{ V}$ (SUM mode)	25	38	ns	
t_{PHL}				25	38		
t_{PLH}	Any \bar{A} or \bar{B}	C_{n+4}	$M = 0\text{ V}$, $S_0 = S_3 = 0\text{ V}$, $S_1 = S_2 = 4.5\text{ V}$ (DIFF mode)	27	41	ns	
t_{PHL}				27	41		
t_{PLH}	C_n	Any F	$M = 0\text{ V}$ (SUM or DIFF mode)	17	26	ns	
t_{PHL}				13	20		
t_{PLH}	Any \bar{A} or \bar{B}	\bar{G}	$M = 0\text{ V}$, $S_0 = S_3 = 4.5\text{ V}$, $S_1 = S_2 = 0\text{ V}$ (SUM mode)	19	29	ns	
t_{PHL}				15	23		
t_{PLH}	Any \bar{A} or \bar{B}	\bar{G}	$M = 0\text{ V}$, $S_0 = S_3 = 0\text{ V}$, $S_1 = S_2 = 4.5\text{ V}$ (DIFF mode)	21	32	ns	
t_{PHL}				21	32		
t_{PLH}	Any \bar{A} or \bar{B}	\bar{F}	$M = 0\text{ V}$, $S_0 = S_3 = 4.5\text{ V}$, $S_1 = S_2 = 0\text{ V}$ (SUM mode)	20	30	ns	
t_{PHL}				20	30		
t_{PLH}	Any \bar{A} or \bar{B}	\bar{F}	$M = 0\text{ V}$, $S_0 = S_3 = 0\text{ V}$, $S_1 = S_2 = 4.5\text{ V}$ (DIFF mode)	20	30	ns	
t_{PHL}				22	33		
t_{PLH}	\bar{A}_i or \bar{B}_i	\bar{F}_i	$M = 0\text{ V}$, $S_0 = S_3 = 4.5\text{ V}$, $S_1 = S_2 = 0\text{ V}$ (SUM mode)	21	32	ns	
t_{PHL}				13	20		
t_{PLH}	\bar{A}_i or \bar{B}_i	\bar{F}_i	$M = 0\text{ V}$, $S_0 = S_3 = 0\text{ V}$, $S_1 = S_2 = 4.5\text{ V}$ (DIFF mode)	21	32	ns	
t_{PHL}				21	32		
t_{PLH}	\bar{A}_i or \bar{B}_i	\bar{F}_i	$M = 4.5\text{ V}$ (logic mode)	22	33	ns	
t_{PHL}				26	38		
t_{PLH}	Any \bar{A} or \bar{B}	$A = B$	$M = 0\text{ V}$, $S_0 = S_3 = 0\text{ V}$, $S_1 = S_2 = 4.5\text{ V}$ (DIFF mode)	33	50	ns	
t_{PHL}				41	62		

† t_{PLH} ≡ propagation delay time, low-to-high-level output

† t_{PHL} ≡ propagation delay time, high-to-low-level output

NOTE 4: See General Information Section for load circuits and voltage waveforms.

schematics of inputs and outputs

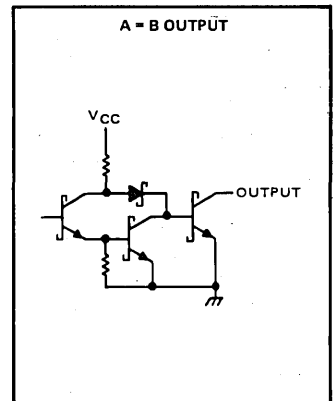
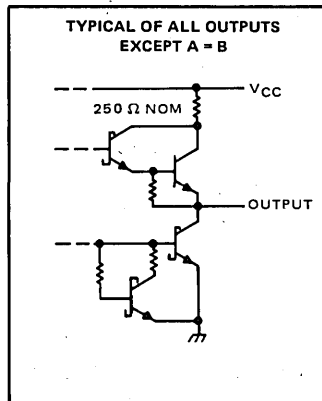
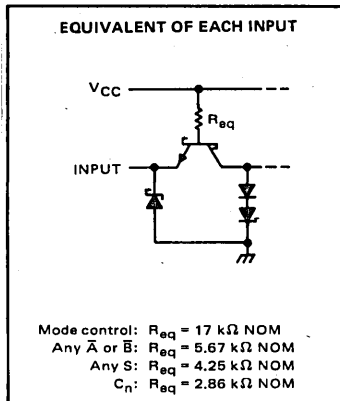

TTL DEVICES

TYPES SN54S181, SN74S181 ARITHMETIC LOGIC UNITS/FUNCTION GENERATORS

absolute maximum ratings over operating free-air temperature range (unless otherwise noted)

Supply voltage, V_{CC} (see Note 1)	7 V
Input voltage	5.5 V
Interemitter voltage (see Note 2)	5.5 V
Operating free-air temperature: SN54S181	-55°C to 125°C
SN74S181	0°C to 70°C
Storage temperature range	-65°C to 150°C

NOTES: 1. Voltage values, except interemitter voltage, are with respect to network ground terminal.
2. This is the voltage between two emitters of a multiple-emitter transistor. For this circuit, this rating applies to each \bar{A} input in conjunction with inputs S2 or S3, and to each \bar{B} input in conjunction with inputs S0 or S3.

recommended operating conditions

	SN54S181			SN74S181			UNIT
	MIN	NOM	MAX	MIN	NOM	MAX	
Supply voltage, V_{CC}	4.5	5	5.5	4.75	5	5.25	V
High-level output current, I_{OH} (All outputs except A = B)			-1			-1	mA
Low-level output current, I_{OL}			20			20	mA
Operating free-air temperature, T_A	-55		125	0		70	°C

electrical characteristics over recommended operating free-air temperature range (unless otherwise noted)

PARAMETER	TEST CONDITIONS†	SN54S181			SN74S181			UNIT
		MIN	TYP‡	MAX	MIN	TYP‡	MAX	
V_{IH} High-level input voltage		2			2		V	
V_{IL} Low-level input voltage				0.8			0.8 V	
V_{IK} Input clamp voltage	$V_{CC} = \text{MIN}, I_I = -18 \text{ mA}$			-1.2			-1.2 V	
V_{OH} High-level output voltage, any output except A = B	$V_{CC} = \text{MIN}, V_{IH} = 2 \text{ V}, V_{IL} = 0.8 \text{ V}, I_{OH} = -1 \text{ mA}$	2.5	3.4		2.7	3.4	V	
I_{OH} High-level output current, A = B output only	$V_{CC} = \text{MIN}, V_{IH} = 2 \text{ V}, V_{IL} = 0.8 \text{ V}, V_{OH} = 5.5 \text{ V}$			250			250 μA	
V_{OL} Low-level output voltage	$V_{CC} = \text{MIN}, V_{IH} = 2 \text{ V}, V_{IL} = 0.8 \text{ V}, I_{OL} = 20 \text{ mA}$			0.5			0.5 V	
I_I Input current at maximum input voltage	$V_{CC} = \text{MAX}, V_I = 5.5 \text{ V}$			1			1 mA	
I_{IH} High-level input current	Mode input			50			50 μA	
	Any \bar{A} or \bar{B} input	$V_{CC} = \text{MAX}, V_I = 2.5 \text{ V}$		150			150	
	Any S input			200			200	
	Carry input			250			250	
I_{IL} Low-level input current	Mode input		$V_{CC} = \text{MAX}, V_I = 0.5 \text{ V}$		-2			-2 mA
	Any \bar{A} or \bar{B} input			-6			-6	
	Any S input			-8			-8	
	Carry input			-10			-10	
I_{OS} Short-circuit output current, any output except A = B §	$V_{CC} = \text{MAX}$	-40		-100	-40		-100 mA	
I_{CC} Supply current	$V_{CC} = \text{MAX}, T_A = 125^\circ\text{C},$ See Note 3	W package only		195			mA	
	$V_{CC} = \text{MAX},$ See Note 3	All packages	120	220	120	220		

† For conditions shown as MIN or MAX, use the appropriate value specified under recommended operating conditions.

‡ All typical values are at $V_{CC} = 5 \text{ V}, T_A = 25^\circ\text{C}$.

§ Not more than one output should be shorted at a time.

NOTE 3: I_{CC} is measured for the following conditions (the typical and maximum values apply to both):

A. S0 through S3, M, and \bar{A} inputs are at 4.5 V, all other inputs are grounded, and all outputs are open.

B. S0 through S3 and M are at 4.5 V, all other inputs grounded, and all outputs are open.

TYPES SN54S181, SN74S181 ARITHMETIC LOGIC UNITS/FUNCTION GENERATORS

switching characteristics, $V_{CC} = 5\text{ V}$, $T_A = 25^\circ\text{C}$ ($C_L = 15\text{ pF}$, $R_L = 280\ \Omega$, see note 4)

PARAMETER [†]	FROM (INPUT)	TO (OUTPUT)	TEST CONDITIONS	MIN	TYP	MAX	UNIT
t_{PLH}	C_n	C_{n+4}		7	10.5		ns
t_{PHL}				7	10.5		
t_{PLH}	Any \bar{A} or \bar{B}	C_{n+4}	$M = 0\text{ V}, S_0 = S_3 = 4.5\text{ V},$ $S_1 = S_2 = 0\text{ V}$ (SUM mode)	12.5	18.5		ns
t_{PHL}				12.5	18.5		
t_{PLH}	Any \bar{A} or \bar{B}	C_{n+4}	$M = 0\text{ V}, S_0 = S_3 = 0\text{ V},$ $S_1 = S_2 = 4.5\text{ V}$ (DIFF mode)	15.5	23		ns
t_{PHL}				15.5	23		
t_{PLH}	C_n	Any \bar{F}	$M = 0\text{ V}$ (SUM or DIFF mode)	7	12		ns
t_{PHL}				7	12		
t_{PLH}	Any \bar{A} or \bar{B}	\bar{G}	$M = 0\text{ V}, S_0 = S_3 = 4.5\text{ V},$ $S_1 = S_2 = 0\text{ V}$ (SUM mode)	8	12		ns
t_{PHL}				7.5	12		
t_{PLH}	Any \bar{A} or \bar{B}	\bar{G}	$M = 0\text{ V}, S_0 = S_3 = 0\text{ V},$ $S_1 = S_2 = 4.5\text{ V}$ (DIFF mode)	10.5	15		ns
t_{PHL}				10.5	15		
t_{PLH}	Any \bar{A} or \bar{B}	\bar{P}	$M = 0\text{ V}, S_0 = S_3 = 4.5\text{ V},$ $S_1 = S_2 = 0\text{ V}$ (SUM mode)	7.5	12		ns
t_{PHL}				7.5	12		
t_{PLH}	Any \bar{A} or \bar{B}	\bar{P}	$M = 0\text{ V}, S_0 = S_3 = 0\text{ V},$ $S_1 = S_2 = 4.5\text{ V}$ (DIFF mode)	10.5	15		ns
t_{PHL}				10.5	15		
t_{PLH}	\bar{A}_i or \bar{B}_i	\bar{F}_i	$M = 0\text{ V}, S_0 = S_3 = 4.5\text{ V},$ $S_1 = S_2 = 0\text{ V}$ (SUM mode)	11	16.5		ns
t_{PHL}				11	16.5		
t_{PLH}	\bar{A}_i or \bar{B}_i	\bar{F}_i	$M = 0\text{ V}, S_0 = S_3 = 0\text{ V},$ $S_1 = S_2 = 4.5\text{ V}$ (DIFF mode)	14	20		ns
t_{PHL}				14	22		
t_{PLH}	\bar{A}_i or \bar{B}_i	\bar{F}_i	$M = 4.5\text{ V}$ (logic mode)	14	20		ns
t_{PHL}				14	22		
t_{PLH}	Any \bar{A} or \bar{B}	$A = B$	$M = 0\text{ V}, S_0 = S_3 = 0\text{ V},$ $S_1 = S_2 = 4.5\text{ V}$ (DIFF mode)	15	23		ns
t_{PHL}				20	30		

[†] t_{PLH} = propagation delay time, low-to-high-level output

[†] t_{PHL} = propagation delay time, high-to-low-level output

NOTE 4: See General Information Section for load circuits and voltage waveforms.

schematics of inputs and outputs

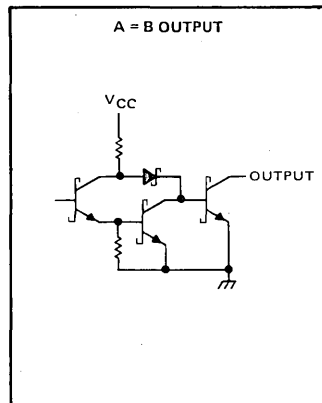
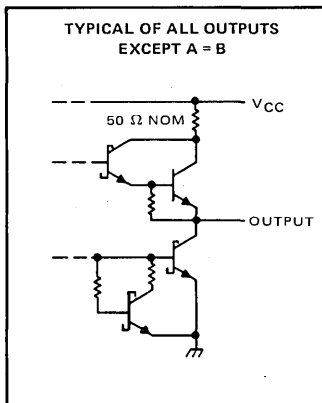
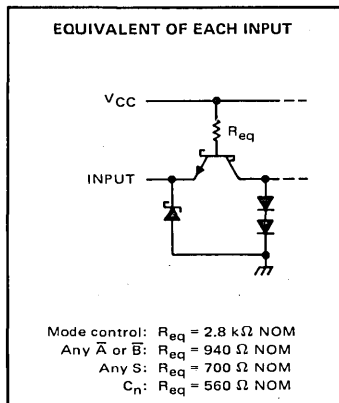

TTL DEVICES

TYPES SN54181, SN54LS181, SN54S181, SN74181, SN74LS181, SN74S181
 ARITHMETIC LOGIC UNITS/FUNCTION GENERATORS

PARAMETER MEASUREMENT INFORMATION

SUM MODE TEST TABLE

FUNCTION INPUTS: S0 = S3 = 4.5 V, S1 = S2 = M = 0 V

PARAMETER	INPUT UNDER TEST	OTHER INPUT SAME BIT		OTHER DATA INPUTS		OUTPUT UNDER TEST	OUTPUT WAVEFORM (See Note 4)
		APPLY 4.5 V	APPLY GND	APPLY 4.5 V	APPLY GND		
¹ PLH	\bar{A}_i	\bar{B}_i	None	Remaining \bar{A} and \bar{B}	C_n	\bar{F}_i	In-Phase
¹ PHL	\bar{B}_i	\bar{A}_i	None	Remaining \bar{A} and \bar{B}	C_n	\bar{F}_i	In-Phase
¹ PLH	\bar{A}_i	\bar{B}_i	None	None	Remaining \bar{A} and \bar{B} , C_n	\bar{P}	In-Phase
¹ PHL	\bar{B}_i	\bar{A}_i	None	None	Remaining \bar{A} and \bar{B} , C_n	\bar{P}	In-Phase
¹ PLH	\bar{A}_i	None	\bar{B}_i	Remaining \bar{B}	Remaining \bar{A} , C_n	\bar{G}	In-Phase
¹ PHL	\bar{B}_i	None	\bar{A}_i	Remaining \bar{B}	Remaining \bar{A} , C_n	\bar{G}	In-Phase
¹ PLH	C_n	None	None	All \bar{A}	All \bar{B}	Any F or C_{n+4}	In-Phase
¹ PHL	\bar{A}_i	None	\bar{B}_i	Remaining \bar{B}	Remaining \bar{A} , C_n	C_{n+4}	Out-of-Phase
¹ PLH	\bar{B}_i	None	\bar{A}_i	Remaining \bar{B}	Remaining \bar{A} , C_n	C_{n+4}	Out-of-Phase

DIFF MODE TEST TABLE

FUNCTION INPUTS: S1 = S2 = 4.5 V, S0 = S3 = M = 0 V

PARAMETER	INPUT UNDER TEST	OTHER INPUT SAME BIT		OTHER DATA INPUTS		OUTPUT UNDER TEST	OUTPUT WAVEFORM (See Note 4)
		APPLY 4.5 V	APPLY GND	APPLY 4.5 V	APPLY GND		
¹ PLH	\bar{A}_i	None	\bar{B}_i	Remaining \bar{A}	Remaining \bar{B} , C_n	\bar{F}_i	In-Phase
¹ PHL	\bar{B}_i	\bar{A}_i	None	Remaining \bar{A}	Remaining \bar{B} , C_n	\bar{F}_i	Out of Phase
¹ PLH	\bar{A}_i	None	\bar{B}_i	None	Remaining \bar{A} and \bar{B} , C_n	\bar{P}	In-Phase
¹ PHL	\bar{B}_i	\bar{A}_i	None	None	Remaining \bar{A} and \bar{B} , C_n	\bar{P}	Out-of-Phase
¹ PLH	\bar{A}_i	\bar{B}_i	None	None	Remaining \bar{A} and \bar{B} , C_n	\bar{G}	In-Phase
¹ PHL	\bar{B}_i	None	\bar{A}_i	None	Remaining \bar{A} and \bar{B} , C_n	\bar{G}	Out-of-Phase
¹ PLH	\bar{A}_i	None	\bar{B}_i	Remaining \bar{A}	Remaining \bar{B} , C_n	A = B	In-Phase
¹ PHL	\bar{B}_i	\bar{A}_i	None	Remaining \bar{A}	Remaining \bar{B} , C_n	A = B	Out-of-Phase
¹ PLH	C_n	None	None	All \bar{A} and \bar{B}	None	C_{n+4} or any F	In-Phase
¹ PHL	\bar{A}_i	\bar{B}_i	None	None	Remaining \bar{A} , \bar{B} , C_n	C_{n+4}	Out-of-Phase
¹ PLH	\bar{B}_i	None	\bar{A}_i	None	Remaining \bar{A} , \bar{B} , C_n	C_{n+4}	In-Phase

LOGIC MODE TEST TABLE

FUNCTION INPUTS: S1 = S2 = M = 4.5 V, S0 = S3 = 0 V

PARAMETER	INPUT UNDER TEST	OTHER INPUT SAME BIT		OTHER DATA INPUTS		OUTPUT UNDER TEST	OUTPUT WAVEFORM (See Note 4)
		APPLY 4.5 V	APPLY GND	APPLY 4.5 V	APPLY GND		
¹ PLH	\bar{A}_i	\bar{B}_i	None	None	Remaining \bar{A} and \bar{B} , C_n	\bar{F}_i	Out-of-Phase
¹ PHL	\bar{B}_i	\bar{A}_i	None	None	Remaining \bar{A} and \bar{B} , C_n	\bar{F}_i	Out-of-Phase

NOTE 4: See General Information Section for load circuits and voltage waveforms.

3

TTL DEVICES

TYPES SN54182, SN54S182, SN74182, SN74S182 LOOK-AHEAD CARRY GENERATORS

BULLETIN NO. DL-S 7611823, DECEMBER 1972—REVISED OCTOBER 1976

- Directly Compatible for Use With:
SN54181/SN74181, SN54LS181/SN74LS181,
SN54S281/SN74S281, SN54S381, SN74S381,
SN54S481/SN74S481

SN54182, SN54S182 . . . J OR W PACKAGE
SN74182 . . . J OR N PACKAGE
SN74S182 . . . D, J OR N PACKAGE
(TOP VIEW)

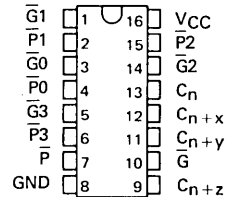

SN54S182 . . . FK PACKAGE
SN74S182 . . . FN PACKAGE
(TOP VIEW)

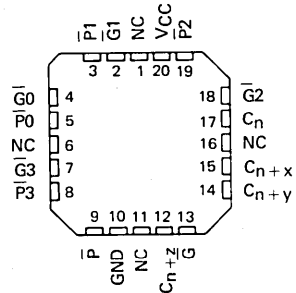

PIN DESIGNATIONS

ALTERNATIVE	DESIGNATIONS†	PIN NOS.	FUNCTION
G0, G1, G2, G3	G0, G1, G2, G3	3, 1, 14, 5	CARRY GENERATE INPUTS
P0, P1, P2, P3	P0, P1, P2, P3	4, 2, 15, 6	CARRY PROPAGATE INPUTS
C _n	C _n	13	CARRY INPUT
C _{n+x} , C _{n+y} , C _{n+z}	C _{n+x} , C _{n+y} , C _{n+z}	12, 11, 9	CARRY OUTPUTS
G	Y	10	CARRY GENERATE OUTPUT
P	X	7	CARRY PROPAGATE OUTPUT
V _{CC}		16	SUPPLY VOLTAGE
GND		8	GROUND

† Interpretations are illustrated in the '181, 'LS181, 'S181 data sheet.

logic symbol†

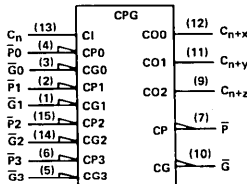

Pin numbers shown on logic notation are for D, J or N packages.

description

The SN54182, SN54S182, SN74182, and SN74S182 are high-speed, look-ahead carry generators capable of anticipating a carry across four binary adders or group of adders. They are cascadable to perform full look-ahead across n-bit adders. Carry, generate-carry, and propagate-carry functions are provided as enumerated in the pin designation table above.

When used in conjunction with the '181, 'LS181, or 'S181 arithmetic logic unit (ALU), these generators provide high-speed carry look-ahead capability for any word length. Each '182 or 'S182 generates the look-ahead (anticipated carry) across a group of four ALU's and, in addition, other carry look-ahead circuits may be employed to anticipate carry across sections of four look-ahead packages up to n-bits. The method of cascading '182 or 'S182 circuits to perform multi-level look-ahead is illustrated under typical application data.

The carry functions (inputs, outputs, generate, and propagate) of the look-ahead generators are implemented in the compatible forms for direct connection to the ALU. Reinterpretations of carry functions as explained on the '181, 'LS181, and 'S181 data sheet are also applicable to and compatible with the look-ahead generator. Logic equations for the '182 and 'S182 are:

$$\begin{aligned}
 C_{n+x} &= G0 + P0 C_n \\
 C_{n+y} &= G1 + P1 G0 + P1 P0 C_n \\
 C_{n+z} &= G2 + P2 G1 + P2 P1 G0 + P2 P1 P0 C_n \\
 \bar{G} &= \bar{G3} + P3 G2 + P3 P2 G1 + P3 P2 P1 G0 \\
 \bar{P} &= P3 P2 P1 P0
 \end{aligned}
 \quad \text{or} \quad
 \begin{aligned}
 \bar{C}_{n+x} &= \bar{Y0} (X0 + \bar{C}_n) \\
 \bar{C}_{n+y} &= \bar{Y1} [X1 + Y0 (X0 + \bar{C}_n)] \\
 \bar{C}_{n+z} &= \bar{Y2} \{ X2 + Y1 [X1 + Y0 (X0 + \bar{C}_n)] \} \\
 Y &= Y3 (X3 + Y2) (X3 + X2 + Y1) (X3 + X2 + X1 + Y0) \\
 X &= X3 + X2 + X1 + X0
 \end{aligned}$$

PRODUCTION DATA
This document contains information current as of publication date. Products conform to specifications per the terms of Texas Instruments standard warranty. Production processing does not necessarily include testing of all parameters.

**TEXAS
INSTRUMENTS**

POST OFFICE BOX 225012 • DALLAS, TEXAS 75265

3-721

TTL DEVICES

3

TYPES SN54182, SN54S182, SN74182, SN74S182 LOOK-AHEAD CARRY GENERATORS

logic

logic diagram

FUNCTION TABLE FOR \bar{G} OUTPUT

INPUTS							OUTPUT
\bar{G}_3	\bar{G}_2	\bar{G}_1	\bar{G}_0	\bar{P}_3	\bar{P}_2	\bar{P}_1	\bar{G}
L	X	X	X	X	X	X	L
X	L	X	X	L	X	X	L
X	X	L	X	L	L	X	L
X	X	X	L	L	L	L	L
All other combinations							H

FUNCTION TABLE FOR \bar{P} OUTPUT

INPUTS				OUTPUT
\bar{P}_3	\bar{P}_2	\bar{P}_1	\bar{P}_0	\bar{P}
L	L	L	L	L
All other combinations				H

FUNCTION TABLE FOR C_{n+x} OUTPUT

INPUTS			OUTPUT
\bar{G}_0	\bar{P}_0	C_n	C_{n+x}
L	X	X	H
X	L	H	H
All other combinations			L

FUNCTION TABLE FOR C_{n+y} OUTPUT

INPUTS					OUTPUT
\bar{G}_1	\bar{G}_0	\bar{P}_1	\bar{P}_0	C_n	C_{n+y}
L	X	X	X	X	H
X	L	L	X	X	H
X	X	L	L	H	H
All other combinations					L

FUNCTION TABLE FOR C_{n+z} OUTPUT

INPUTS							OUTPUT
\bar{G}_2	\bar{G}_1	\bar{G}_0	\bar{P}_2	\bar{P}_1	\bar{P}_0	C_n	C_{n+z}
L	X	X	X	X	X	X	H
X	L	X	L	X	X	X	H
X	X	L	L	L	X	X	H
X	X	X	L	L	L	H	H
All other combinations							L

H = high level, L = low level, X = Irrelevant

Any Inputs not shown in a given table are Irrelevant with respect to that output.

absolute maximum ratings over operating free-air temperature range (unless otherwise noted)

Supply voltage, V_{CC} (see Note 1)	7 V
Input voltage	5.5 V
Intermitter voltage (see Note 2)	5.5 V
Operating free-air temperature range: SN54', SN54S' Circuits	-55°C to 125°C
SN74', SN74S' Circuits	0°C to 70°C
Storage temperature range	-65°C to 150°C

NOTES: 1. Voltage values, except intermitter voltage, are with respect to network ground terminal.

2. This is the voltage between two emitters of a multiple-emitter input transistor. For these circuits, this rating applies to each \bar{G} input in conjunction with any other \bar{G} input or in conjunction with any \bar{P} input.

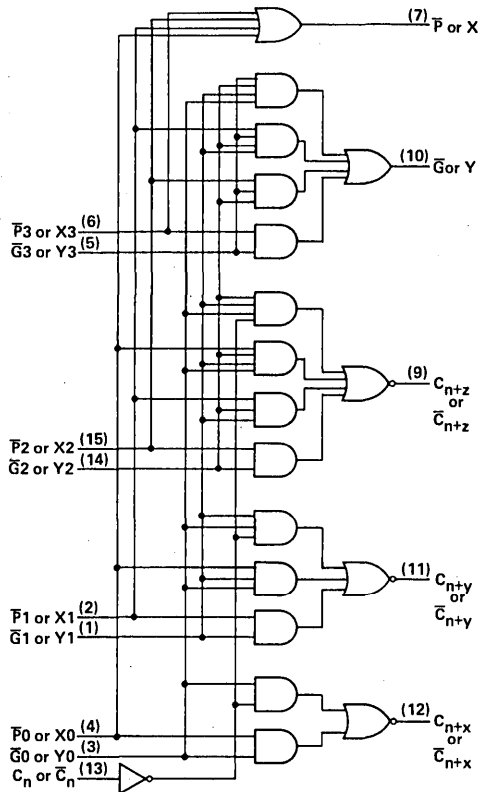

Pin numbers shown on logic notation are for D, J or N packages.

TYPES SN54182, SN74182 LOOK-AHEAD CARRY GENERATORS

recommended operating conditions

	SN54182			SN74182			UNIT
	MIN	NOM	MAX	MIN	NOM	MAX	
Supply voltage, V_{CC}	4.5	5	5.5	4.75	5	5.25	V
High-level output current, I_{OH}			-800			-800	μ A
Low-level output current, I_{OL}			16			16	mA
Operating free-air temperature, T_A	-55		125	0		70	$^{\circ}$ C

electrical characteristics over recommended operating free-air temperature range (unless otherwise noted)

PARAMETER		TEST CONDITIONS†	SN54182			SN74182			UNIT
			MIN	TYP‡	MAX	MIN	TYP‡	MAX	
V_{IH}	High-level input voltage		2			2			V
V_{IL}	Low-level input voltage		0.8			0.8			V
V_{IK}	Input clamp voltage	$V_{CC} = \text{MIN}, I_I = -12 \text{ mA}$	-1.5			-1.5			V
V_{OH}	High-level output voltage	$V_{CC} = \text{MIN}, V_{IH} = 2 \text{ V}, V_{IL} = 0.8 \text{ V}, I_{OH} = -800 \mu\text{A}$	2.4	3.4		2.4	3.4		V
V_{OL}	Low-level output voltage	$V_{CC} = \text{MIN}, V_{IH} = 2 \text{ V}, V_{IL} = 0.8 \text{ V}, I_{OL} = 16 \text{ mA}$		0.2	0.4		0.2	0.4	V
I_I	Input current at maximum input voltage	$V_{CC} = \text{MAX}, V_I = 5.5 \text{ V}$		1			1		mA
I_{IH}	High-level input current	C_n input		80			80		μ A
		$\bar{P}3$ input		120			120		
		$\bar{P}2$ input		160			160		
		$\bar{P}0, \bar{P}1, \text{ or } \bar{G}3$ input		200			200		
		$\bar{G}0 \text{ or } \bar{G}2$ input		360			360		
		$\bar{G}1$ input		400			400		
I_{IL}	Low-level input current	C_n input		-3.2			-3.2		mA
		$\bar{P}3$ input		-4.8			-4.8		
		$\bar{P}2$ input		-6.4			-6.4		
		$\bar{P}0, \bar{P}1, \text{ or } \bar{G}3$ input		-8			-8		
		$\bar{G}0 \text{ or } \bar{G}2$ input		-14.4			-14.4		
		$\bar{G}1$ input		-16			-16		
I_{OS}	Short-circuit output current §	$V_{CC} = \text{MAX}$	-40	-100		-40	-100		mA
I_{CCH}	Supply current, all outputs high	$V_{CC} = 5 \text{ V}$, See Note 3	27			27			mA
I_{CCL}	Supply current, all outputs low	$V_{CC} = \text{MAX}$, See Note 4	45	65		45	72		mA

† For conditions shown as MIN or MAX, use the appropriate value specified under recommended operating conditions.

‡ All typical values are at $V_{CC} = 5 \text{ V}, T_A = 25^{\circ}\text{C}$.

§ Not more than one output should be shorted at a time and duration of the short-circuit test should not exceed one second.

NOTES: 3. I_{CCH} is measured with all outputs open, inputs $\bar{P}3$ and $\bar{G}3$ at 4.5 V, and all other inputs grounded.

4. I_{CCL} is measured with all outputs open; inputs $\bar{G}0, \bar{G}1$, and $\bar{G}2$ at 4.5 V; and all other inputs grounded.

switching characteristics, $V_{CC} = 5 \text{ V}, T_A = 25^{\circ}\text{C}$

PARAMETER		TEST CONDITIONS	MIN	TYP	MAX	UNIT
t_{PLH}	Propagation delay time, low-to-high-level output		$C_L = 15 \text{ pF}, R_L = 400 \Omega$, See Note 5		11	17
t_{PHL}	Propagation delay time, high-to-low-level output			15	22	ns

NOTE 5: See General Information Section for load circuits and voltage waveforms.

TYPES SN54S182, SN74S182 LOOK-AHEAD CARRY GENERATORS

recommended operating conditions

	SN54S182			SN74S182			UNIT
	MIN	NOM	MAX	MIN	NOM	MAX	
Supply voltage, V_{CC}	4.5	5	5.5	4.75	5	5.25	V
High-level output current, I_{OH}			-1			-1	mA
Low-level output current, I_{OL}			20			20	mA
Operating free-air temperature, T_A	-55		125	0		70	°C

electrical characteristics over recommended operating free-air temperature range (unless otherwise noted)

PARAMETER		TEST CONDITIONS†	SN54S182			SN74S182			UNIT
			MIN	TYP‡	MAX	MIN	TYP‡	MAX	
V_{IH}	High-level input voltage		2			2			V
V_{IL}	Low-level input voltage				0.8			0.8	V
V_{IK}	Input clamp voltage	$V_{CC} = \text{MIN}, I_I = -18 \text{ mA}$			-1.2			-1.2	V
V_{OH}	High-level output voltage	$V_{CC} = \text{MIN}, V_{IH} = 2 \text{ V}, V_{IL} = 0.8 \text{ V}, I_{OH} = -1 \text{ mA}$	2.5	3.4		2.7	3.4		V
V_{OL}	Low-level output voltage	$V_{CC} = \text{MIN}, V_{IH} = 2 \text{ V}, V_{IL} = 0.8 \text{ V}, I_{OL} = 20 \text{ mA}$			0.5			0.5	V
I_I	Input current at maximum input voltage	$V_{CC} = \text{MAX}, V_I = 5.5 \text{ V}$			1			1	mA
I_{IH}	High-level input current	C_n input			50			50	μA
		$\bar{P}3$ input			100			100	
		$\bar{P}2$ input			150			150	
		$\bar{P}0, \bar{P}1, \text{ or } \bar{G}3$ input			200			200	
		$\bar{G}0$ or $\bar{G}2$ input			350			350	
		$\bar{G}1$ input			400			400	
I_{IL}	Low-level input current	C_n input			-2			-2	mA
		$\bar{P}3$ input			-4			-4	
		$\bar{P}2$ input			-6			-6	
		$\bar{P}0, \bar{P}1, \text{ or } \bar{G}3$ input			-8			-8	
		$\bar{G}0$ or $\bar{G}2$ input			-14			-14	
		$\bar{G}1$ input			-16			-16	
I_{OS}	Short-circuit output current§	$V_{CC} = \text{MAX}$	-40	-100		-40	-100	mA	
I_{CCH}	Supply current, all outputs high	$V_{CC} = 5 \text{ V}$, See Note 3		35			35	mA	
I_{CCL}	Supply current, all outputs low	$V_{CC} = \text{MAX}$, See Note 4		69	99		69	109	mA

†For conditions shown as MIN or MAX, use the appropriate value specified under recommended operating conditions for the applicable type.
‡All typical values are at $V_{CC} = 5 \text{ V}, T_A = 25^\circ\text{C}$.

§Not more than one output should be shorted at a time and duration of the short-circuit test should not exceed one second.

NOTES: 3. I_{CCH} is measured with all outputs open, inputs $\bar{P}3$ and $\bar{G}3$ at 4.5 V, and all other inputs grounded.

4. I_{CCL} is measured with all outputs open; inputs $\bar{G}0, \bar{G}1$, and $\bar{G}2$ at 4.5 V; and all other inputs grounded.

switching characteristics, $V_{CC} = 5 \text{ V}, T_A = 25^\circ\text{C}$

PARAMETER¶	FROM (INPUT)	TO (OUTPUT)	TEST CONDITIONS	MIN	TYP	MAX	UNIT
t_{PLH}	$\bar{G}0, \bar{G}1, \bar{G}2, \bar{G}3$	C_{n+x}, C_{n+y} , or C_{n+z}	$R_L = 280 \Omega, C_L = 15 \text{ pF}$, See Note 5		4.5	7	ns
t_{PHL}	$P0, P1, P2$, or $P3$				4.5	7	
t_{PLH}	$\bar{G}0, \bar{G}1, \bar{G}2, \bar{G}3$	\bar{G}			5	7.5	ns
t_{PHL}	$P1, P2$, or $P3$				7	10.5	
t_{PLH}	$\bar{P}0, \bar{P}1, \bar{P}2$, or $\bar{P}3$	\bar{P}			4.5	6.5	ns
t_{PHL}					6.5	10	
t_{PLH}	C_n	C_{n+x}, C_{n+y} , or C_{n+z}			6.5	10	ns
t_{PHL}					7	10.5	

¶ t_{PLH} ≡ propagation delay time, low-to-high-level output

t_{PHL} ≡ propagation delay time, high-to-low-level output

NOTE 5: See General Information Section for load circuits and voltage waveforms.

TYPES SN54182, SN54S182, SN74182, SN74S182
LOOK-AHEAD CARRY GENERATORS

schematics of inputs and outputs

'182

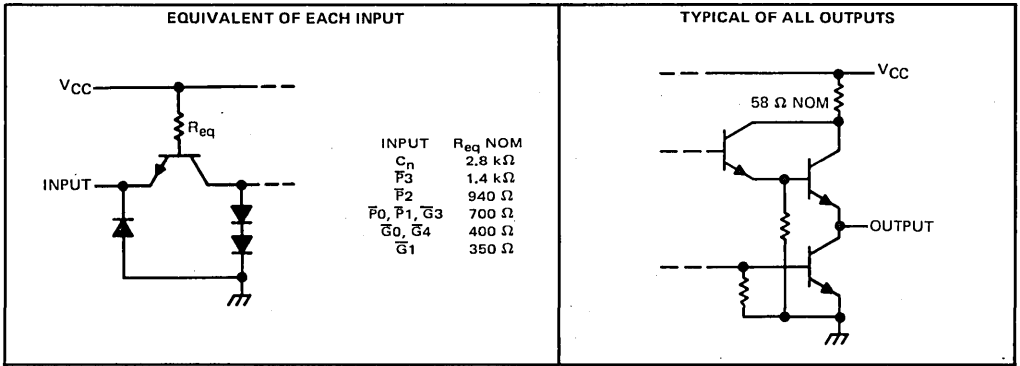

'S182

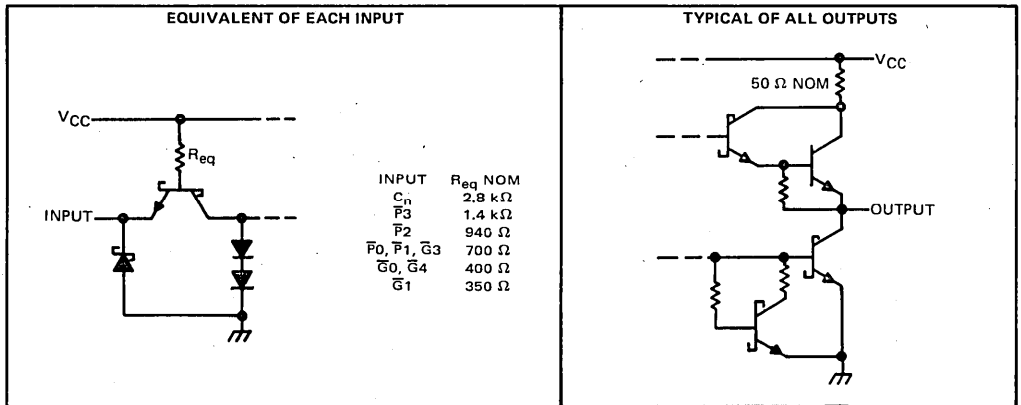

3
TTL DEVICES

TYPICAL APPLICATION DATA

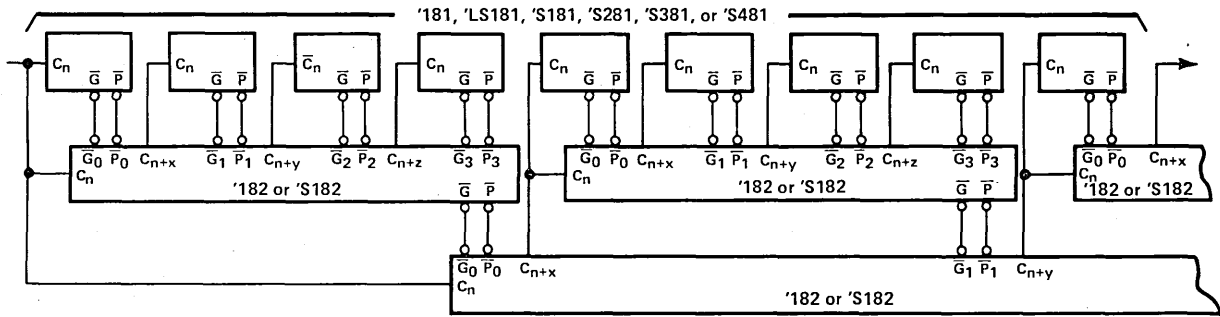

64-BIT ALU, FULL-CARRY LOOK-AHEAD IN THREE LEVELS

Remaining inputs and outputs of '181, 'LS181, 'S181, 'S281, 'S381, and 'S481 are not shown.

TYPES SN54H183, SN54LS183, SN74H183, SN74LS183 DUAL CARRY-SAVE FULL ADDERS

BULLETIN NO. DL-S-7711848, OCTOBER 1976—REVISED OCTOBER 1983

- For Use in High-Speed Wallace-Tree Summing Networks
- High-Speed, High-Fan-Out Darlington Outputs
- Input Clamping Diodes Simplify System Design

TYPES	TYPICAL AVERAGE PROPAGATION DELAY TIME	TYPICAL POWER DISSIPATION
'H183	11 ns	110 mW per bit
'LS183	15 ns	23 mW per bit

SN54H183, SN54LS183 ... J OR W PACKAGE
SN74H183 ... J OR N PACKAGE
SN74LS183 ... D, J OR N PACKAGE

(TOP VIEW)

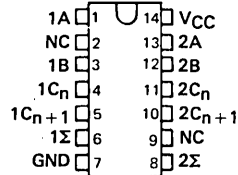

SN54LS183 ... FK PACKAGE
SN74LS183 ... FN PACKAGE

(TOP VIEW)

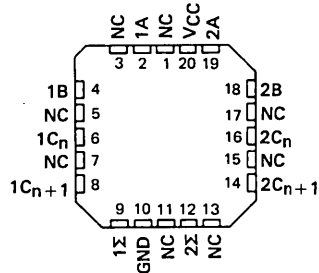

NC - No internal connection

FUNCTION TABLE
(EACH ADDER)

INPUTS		OUTPUTS		
C_n	B	A	Σ	C_{n+1}
L	L	L	L	L
L	L	H	H	L
L	H	L	H	L
L	H	H	L	H
H	L	L	H	L
H	L	H	L	H
H	H	L	L	H
H	H	H	H	H

H = high level, L = low level

logic diagram (each adder)

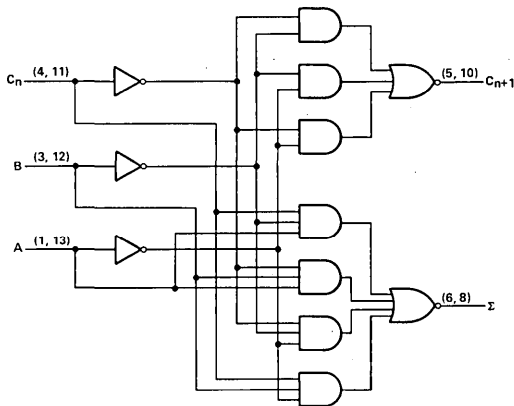

Pin numbers shown on logic notation are for D, J or N packages.

schematics of inputs and outputs

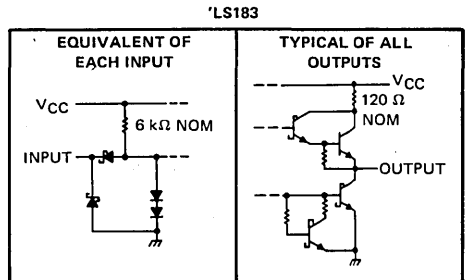
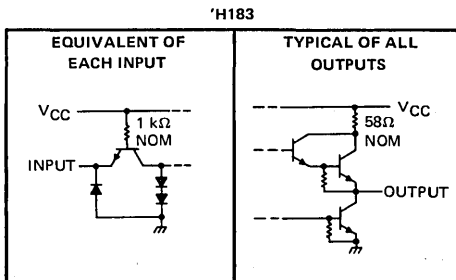

PRODUCTION DATA
This document contains information current as of publication date. Products conform to specifications per the terms of Texas Instruments standard warranty. Production processing does not necessarily include testing of all parameters.

TEXAS INSTRUMENTS
POST OFFICE BOX 225012 • DALLAS, TEXAS 75265

3

TTL DEVICES

3-727

TYPES SN54H183, SN74H183 DUAL CARRY-SAVE FULL ADDERS

description

These dual full adders feature an individual carry output from each bit for use in multiple-input, carry-save techniques to produce the true sum and true carry outputs with no more than two gate delays. The circuits utilize high-speed, high-fan-out, transistor-transistor logic (TTL), but are compatible with both DTL and TTL families. Series 54H and 54LS devices are characterized for operation over the full military temperature range of -55°C to 125°C ; Series 74H and 74LS devices are characterized for operation from 0°C to 70°C .

absolute maximum ratings over operating free-air temperature range (unless otherwise noted)

Supply voltage V_{CC} (see Note 1)	7 V
Input voltage	5.5 V
Interemitter voltage (see Note 2)	5.5 V
Operating free-air temperature range: SN54H183 Circuits	-55°C to 125°C
SN74H183 Circuits	0°C to 70°C
Storage temperature range	-65°C to 150°C

- NOTES: 1. Voltage values, except interemitter voltage, are with respect to network ground terminal.
2. This is the voltage between two emitters of a multiple-emitter transistor. For this circuit, this rating applies between any two inputs to the same adder.

recommended operating conditions

	SN54H183			SN74H183			UNIT
	MIN	NOM	MAX	MIN	NOM	MAX	
Supply voltage, V_{CC}	4.5	5	5.5	4.75	5	5.25	V
High-level output current, I_{OH}			-1			-1	mA
Low-level output current, I_{OL}			20			20	mA
Operating free-air temperature, T_A	-55		125	0		70	$^{\circ}\text{C}$

electrical characteristics over recommended operating free-air temperature range (unless otherwise noted)

PARAMETER	TEST CONDITIONS [†]	MIN	TYP [‡]	MAX	UNIT
V_{IH} High-level input voltage		2			V
V_{IL} Low-level input voltage				0.8	V
V_{IK} Input clamp voltage	$V_{CC} = \text{MIN}$, $I_I = -8 \text{ mA}$			-1.5	V
V_{OH} High-level output voltage	$V_{CC} = \text{MIN}$, $V_{IH} = 2 \text{ V}$, $V_{IL} = 0.8 \text{ V}$, $I_{OH} = -1 \text{ mA}$	2.4	3.5		V
V_{OL} Low-level output voltage	$V_{CC} = \text{MIN}$, $V_{IH} = 2 \text{ V}$, $V_{IL} = 0.8 \text{ V}$, $I_{OL} = 20 \text{ mA}$		0.2	0.4	V
I_I Input current at maximum input voltage	$V_{CC} = \text{MAX}$, $V_I = 5.5 \text{ V}$			1	mA
I_{IH} High-level input current	$V_{CC} = \text{MAX}$, $V_I = 2.4 \text{ V}$			150	μA
I_{IL} Low-level input current	$V_{CC} = \text{MAX}$, $V_I = 0.4 \text{ V}$			-6	mA
I_{OS} Short-circuit output current [§]	$V_{CC} = \text{MAX}$	-40		-100	mA
I_{CCL} Supply current, all outputs low	$V_{CC} = \text{MAX}$, SN54H183 See Note 3, SN74H183		48	69	mA
I_{CCH} Supply current, all outputs high	$V_{CC} = \text{MAX}$, See Note 4		40	65	mA

[†] For conditions shown as MIN or MAX, use the appropriate value specified under recommended operating conditions for the applicable type.

[‡] All typical values are at $V_{CC} = 5 \text{ V}$, $T_A = 25^{\circ}\text{C}$.

[§] Not more than one output should be shorted at a time, and duration of the short circuit should not exceed one second.

NOTES: 3. I_{CCL} is measured with all outputs open and all inputs grounded.

4. I_{CCH} is measured with all outputs open and all inputs at 4.5 V.

switching characteristics, $V_{CC} = 5 \text{ V}$, $T_A = 25^{\circ}\text{C}$

PARAMETER	TEST CONDITIONS	MIN	TYP	MAX	UNIT
t_{PLH} Propagation delay time, low-to-high-level output	$C_L = 25 \text{ pF}$, $R_L = 280 \Omega$		10	15	ns
t_{PHL} Propagation delay time, high-to-low-level output	See Note 5		12	18	ns

NOTE 5: See General Information Section for load circuits and voltage waveforms.

TYPES SN54LS183, SN74LS183 DUAL CARRY-SAVE FULL ADDERS

absolute maximum ratings over operating free-air temperature range (unless otherwise noted)

Supply voltage V_{CC} (see Note 1)	7 V
Input voltage	7 V
Operating free-air temperature range: SN54LS183 Circuits	-55°C to 125°C
SN74LS183 Circuits	0°C to 70°C
Storage temperature range	-65°C to 150°C

NOTE 1: Voltage values, except interemitter voltage, are with respect to network ground terminal.

recommended operating conditions

	SN54LS183			SN74LS183			UNIT	
	MIN	NOM	MAX	MIN	NOM	MAX		
Supply voltage, V_{CC}	4.5	5	5.5	4.75	5	5.25	V	
High-level output current, I_{OH}	-400			-400			μ A	
Low-level output current, I_{OL}	4			8			mA	
Operating free-air temperature, T_A	-55			0			70	°C

electrical characteristics over recommended operation free-air temperature range (unless otherwise noted)

PARAMETER	TEST CONDITIONS†	SN54LS183			SN74LS183			UNIT	
		MIN	TYP‡	MAX	MIN	TYP‡	MAX		
V_{IH} High-level input voltage		2			2			V	
V_{IL} Low-level input voltage		0.7			0.8			V	
V_{IK} Input clamp voltage	$V_{CC} = \text{MIN}, I_I = -18 \text{ mA}$	-1.5			-1.5			V	
V_{OH} High-level output voltage	$V_{CC} = \text{MIN}, V_{IH} = 2 \text{ V}, V_{IL} = V_{IL \text{ max}}, I_{OH} = -400 \mu\text{A}$	2.5	3.4		2.7	3.4		V	
V_{OL} Low-level output voltage	$V_{CC} = \text{MIN}, I_{OL} = 4 \text{ mA}$	0.25			0.25			V	
	$V_{IH} = 2 \text{ V}, V_{IL} = V_{IL \text{ max}}, I_{OL} = 8 \text{ mA}$	0.35			0.5				
I_I Input current at maximum input voltage	$V_{CC} = \text{MAX}, V_I = 7 \text{ V}$	0.3			0.3			mA	
I_{IH} High-level input current	$V_{CC} = \text{MAX}, V_I = 2.7 \text{ V}$	60			60			μ A	
I_{IL} Low-level input current	$V_{CC} = \text{MAX}, V_I = 0.4 \text{ V}$	-1.2			-1.2			mA	
I_{OS} Short-circuit output current§	$V_{CC} = \text{MAX}$	-20		-100	-20		-100	mA	
I_{CCL} Supply current, all outputs low	$V_{CC} = \text{MAX}$, See Note 3	10			10			17	mA
I_{CCH} Supply current, all outputs high	$V_{CC} = \text{MAX}$, See Note 4	8			8			14	mA

† For conditions shown as MIN or MAX, use the appropriate value specified under recommended operating conditions for the applicable type.

‡ All typical values are at $V_{CC} = 5 \text{ V}, T_A = 25^\circ\text{C}$.

§ Not more than one output should be shorted at a time, and duration of the short circuit should not exceed one second.

NOTES: 3. I_{CCL} is measured with all outputs open and all inputs grounded.

4. I_{CCH} is measured with all outputs open and all inputs at 4.5 V.

switching characteristics, $V_{CC} = 5 \text{ V}, T_A = 25^\circ\text{C}$

PARAMETER	TEST CONDITIONS	MIN	TYP	MAX	UNIT
t_{PLH} Propagation delay time, low-to-high-level output	$C_L = 15 \text{ pF}, R_L = 2 \text{ k}\Omega$,	9		15	ns
t_{PHL} Propagation delay time, high-to-low-level output	See Note 5	20		33	ns

NOTE 5: See General Information Section for load circuits and voltage waveforms.



TTL DEVICES

TYPES SN54184, SN54185A, SN74184, SN74185A BCD-TO-BINARY AND BINARY-TO-BCD CONVERTERS

FEBRUARY 1971—REVISED DECEMBER 1972

SN54184, SN74184 BCD-TO-BINARY CONVERTERS SN54185A, SN74185A BINARY-TO-BCD CONVERTERS

SN54184, SN54185A . . . J OR W PACKAGE
SN74184, SN74185A . . . J OR N PACKAGE
(TOP VIEW)

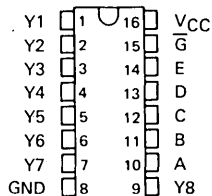

description

These monolithic converters are derived from the custom MSI 256-bit read-only memories SN5488 and SN7488. Emitter connections are made to provide direct read-out of converted codes at outputs Y8 through Y1 as shown in the function tables. These converters demonstrate the versatility of a read-only memory in that an unlimited number of reference tables or conversion tables may be built into a system using economical, customized read-only memories. Both of these converters comprehend that the least significant bits (LSB) of the binary and BCD codes are logically equal, and in each case the LSB bypasses the converter as illustrated in the typical applications. This means that a 6-bit converter is produced in each case. Both devices are cascadable to N bits.

TABLE I
SN54184, SN74184
PACKAGE COUNT AND DELAY TIMES
FOR BCD-TO-BINARY CONVERSION

INPUT (DECADES)	PACKAGES REQUIRED	TOTAL DELAY TIMES (ns)	
		TYP	MAX
2	2	56	80
3	6	140	200
4	11	196	280
5	19	280	400
6	28	364	520

An overriding enable input is provided on each converter which, when taken high, inhibits the function, causing all outputs to go high. For this reason, and to minimize power consumption, unused outputs Y7 and Y8 of the '185A and all "don't care" conditions of the '184 are programmed high. The outputs are of the open-collector type.

The SN54184 and SN54185A are characterized for operation over the full military temperature range of -55°C to 125°C ; the SN74184 and SN74185A are characterized for operation from 0°C to 70°C .

SN54184 and SN74184 BCD-to-binary converters

The 6-bit BCD-to-binary function of the SN54184 and SN74184 is analogous to the algorithm:

- Shift BCD number right one bit and examine each decade. Subtract three from each 4-bit decade containing a binary value greater than seven.
- Shift right, examine, and correct after each shift until the least significant decade contains a number smaller than eight and all other converted decades contain zeros.

In addition to BCD-to-binary conversion, the SN54184 and SN74184 are programmed to generate BCD 9's complement or BCD 10's complement. Again, in each case, one bit of the complement code is logically equal to one of the BCD bits; therefore, these complements can be produced on three lines. As outputs Y6, Y7, and Y8 are not required in the BCD-to-binary conversion, they are utilized to provide these complement codes as specified in the function table (following page, right) when the devices are connected as shown above the function table.

PRODUCTION DATA
This document contains information current as of publication date. Products conform to specifications per the terms of Texas Instruments standard warranty. Production processing does not necessarily include testing of all parameters.

TEXAS INSTRUMENTS
POST OFFICE BOX 225012 • DALLAS, TEXAS 75285

TYPES SN54184, SN74184 BCD-TO-BINARY AND BINARY-TO-BCD CONVERTERS

SN54184 and SN74184 BCD-to-binary (continued)

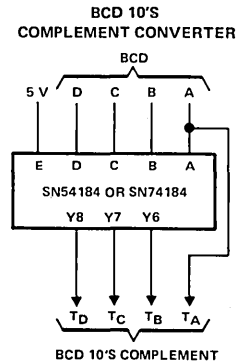
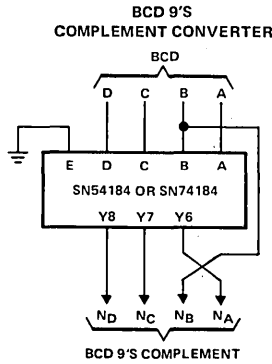
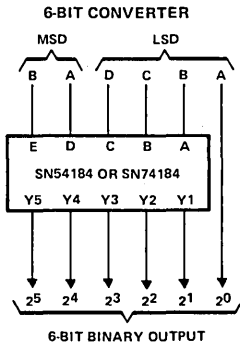

**FUNCTION TABLE
BCD-TO-BINARY
CONVERTER**

BCD WORDS	INPUTS (See Note A)					OUTPUTS (See Note B)					
	E	D	C	B	A	\bar{G}	Y5	Y4	Y3	Y2	Y1
0-1	L	L	L	L	L	L	L	L	L	L	L
2-3	L	L	L	L	H	L	L	L	L	L	H
4-5	L	L	L	H	L	L	L	L	H	L	L
6-7	L	L	L	H	H	L	L	L	H	H	L
8-9	L	L	H	L	L	L	L	L	H	L	L
10-11	L	H	L	L	L	L	L	L	H	L	H
12-13	L	H	L	L	H	L	L	L	H	H	L
14-15	L	H	L	H	L	L	L	L	H	H	H
16-17	L	H	L	H	H	L	L	H	L	L	L
18-19	L	H	H	L	L	L	L	H	L	L	H
20-21	H	L	L	L	L	L	L	H	L	H	L
22-23	H	L	L	L	H	L	L	H	L	H	H
24-25	H	L	L	H	L	L	L	H	H	L	L
26-27	H	L	L	H	H	L	L	H	L	H	H
28-29	H	L	H	L	L	L	L	H	H	H	L
30-31	H	H	L	L	L	L	L	H	H	H	H
32-33	H	H	L	L	H	L	H	L	L	L	L
34-35	H	H	L	H	L	L	H	L	L	L	H
36-37	H	H	L	H	H	L	H	L	L	H	L
38-39	H	H	H	L	L	L	H	L	L	H	H
ANY	X	X	X	X	X	H	H	H	H	H	H

H = high level, L = low level, X = irrelevant

NOTES: A. Input conditions other than those shown produce highs at outputs Y1 through Y5.

B. Outputs Y6, Y7, and Y8 are not used for BCD-to-binary conversion.

**FUNCTION TABLE
BCD 9'S OR BCD 10'S
COMPLEMENT CONVERTER**

BCD WORD	INPUTS (See Note C)					OUTPUTS (See Note D)			
	E [†]	D	C	B	A	\bar{G}	Y8	Y7	Y6
0	L	L	L	L	L	L	H	L	H
1	L	L	L	L	H	L	H	L	L
2	L	L	L	H	L	L	L	H	L
3	L	L	L	H	H	L	L	H	L
4	L	L	H	L	L	L	L	H	H
5	L	L	H	L	H	L	L	L	H
6	L	L	H	H	L	L	L	L	H
7	L	L	H	H	H	L	L	L	L
8	L	H	L	L	L	L	L	L	H
9	L	H	L	L	H	L	L	L	L
0	H	L	L	L	L	L	L	L	L
1	H	L	L	L	H	L	L	L	L
2	H	L	L	H	L	L	H	L	L
3	H	L	L	H	H	L	L	H	H
4	H	L	H	L	L	L	L	H	H
5	H	L	H	L	H	L	L	H	L
6	H	L	H	H	L	L	L	H	L
7	H	L	H	H	H	L	L	L	H
8	H	H	L	L	L	L	L	L	H
9	H	H	L	L	H	L	L	L	L
ANY	X	X	X	X	X	H	H	H	H

H = high level, L = low level, X = irrelevant

NOTES: C. Input conditions other than those shown produce highs at outputs Y6, Y7, and Y8.

D. Outputs Y1 through Y5 are not used for BCD 9's or BCD 10's complement conversion.

[†]When these devices are used as complement converters, Input E is used as a mode control. With this input low, the BCD 9's complement is generated; when it is high, the BCD 10's complement is generated.

TYPES SN54185A, SN74185A BCD-TO-BINARY AND BINARY-TO-BCD CONVERTERS

SN54185A and SN74185A binary-to-BCD converters

The function performed by these 6-bit binary-to-BCD converters is analogous to the algorithm:

- a. Examine the three most significant bits. If the sum is greater than four, add three and shift left one bit.
- b. Examine each BCD decade. If the sum is greater than four, add three and shift left one bit.
- c. Repeat step b until the least-significant binary bit is in the least-significant BCD location.

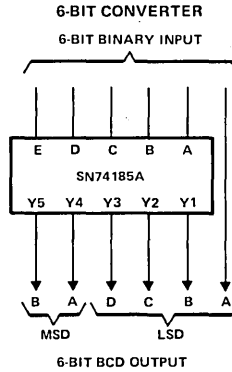

TABLE II

SN54185A, SN74185A

PACKAGE COUNT AND DELAY TIMES
FOR BINARY-TO-BCD CONVERSION

INPUT (BITS)	PACKAGES REQUIRED	TOTAL DELAY TIME (ns)	
		TYP	MAX
4 to 6	1	25	40
7 or 8	3	50	80
9	4	75	120
10	6	100	160
11	7	125	200
12	8	125	200
13	10	150	240
14	12	175	280
15	14	175	280
16	16	200	320
17	19	225	360
18	21	225	360
19	24	250	400
20	27	275	440

FUNCTION TABLE

BINARY WORDS	INPUTS					ENABLE \bar{G}	OUTPUTS						
	BINARY SELECT E D C B A	Y8	Y7	Y6	Y5		Y4	Y3	Y2	Y1			
0-1	L L L L L L	L	H	H	L	L	L	L	L	L	L	L	L
2-3	L L L L H H	L	H	H	L	L	L	L	L	L	L	L	H
4-5	L L L H L L	L	H	H	L	L	H	H	L	L	L	H	L
6-7	L L L H H H	L	H	H	L	L	H	H	L	L	L	H	H
8-9	L L H L L L	L	H	H	L	L	H	H	L	L	H	L	L
10-11	L L H L H L	L	H	H	L	L	H	H	L	H	L	L	L
12-13	L L H H L L	L	H	H	L	L	H	H	L	H	L	L	H
14-15	L L H H H H	L	H	H	L	L	H	H	L	H	L	H	L
16-17	L H L L L L	L	H	H	L	L	H	H	L	L	H	L	H
18-19	L H L L H L	L	H	H	L	L	H	H	L	H	L	H	L
20-21	L H L H L L	L	H	H	L	L	H	H	L	H	L	L	L
22-23	L H L H H L	L	H	H	L	L	H	H	L	H	L	L	H
24-25	L H H L L L	L	H	H	L	L	H	H	L	H	L	L	H
26-27	L H H L H L	L	H	H	L	L	H	H	L	H	L	H	H
28-29	L H H H L L	L	H	H	L	L	H	H	L	H	L	H	L
30-31	L H H H H L	L	H	H	L	L	H	H	L	H	L	L	L
32-33	H L L L L L	L	H	H	L	L	H	H	L	H	L	L	H
34-35	H L L L H L	L	H	H	L	L	H	H	L	H	L	H	L
36-37	H L L H L L	L	H	H	L	L	H	H	L	H	L	H	H
38-39	H L L H H L	L	H	H	L	L	H	H	L	H	L	H	L
40-41	H L H L L L	L	H	H	L	L	H	H	L	L	L	L	L
42-43	H L H L H L	L	H	H	L	L	H	H	L	L	L	L	H
44-45	H L H H L L	L	H	H	L	L	H	H	L	L	L	H	L
46-47	H L H H H L	L	H	H	L	L	H	H	L	L	L	H	H
48-49	H H L L L L	L	H	H	L	L	H	H	L	L	H	L	L
50-51	H H L L H L	L	H	H	L	L	H	H	L	H	L	L	L
52-53	H H L H L L	L	H	H	L	L	H	H	L	H	L	L	H
54-55	H H L H H L	L	H	H	L	L	H	H	L	H	L	H	L
56-57	H H H L L L	L	H	H	L	L	H	H	L	H	L	H	H
58-59	H H H L H L	L	H	H	L	L	H	H	L	H	H	L	L
60-61	H H H H L L	L	H	H	L	L	H	H	L	L	L	L	L
62-63	H H H H H L	L	H	H	L	L	H	H	L	L	L	L	H
ALL	X X X X X	H	H	H	H	H	H	H	H	H	H	H	H

H = high level, L = low level, X = irrelevant

TYPES SN54184, SN54185A, SN74184, SN74185A BCD-TO-BINARY AND BINARY-TO-BCD CONVERTERS

absolute maximum ratings over operating free-air temperature range (unless otherwise noted)

Supply voltage, V_{CC} (see Note 1)	7 V
Input voltage	5.5 V
Operating free-air temperature range: SN54184, SN54185A	-55°C to 125°C
SN74184, SN74185A	0°C to 70°C
Storage temperature range	-65°C to 150°C

NOTE 1: Voltage values are with respect to network ground terminal.

recommended operating conditions

	SN54184, SN54185A			SN74184, SN74185A			UNIT
	MIN	NOM	MAX	MIN	NOM	MAX	
Supply voltage, V_{CC}	4.5	5	5.5	4.75	5	5.25	V
Low-level output current, I_{OL}			12			12	mA
Operating free-air temperature, T_A	-55		125	0		70	°C

electrical characteristics over recommended operating free-air temperature range (unless otherwise noted)

PARAMETER	TEST CONDITIONS [†]	MIN	TYP [‡]	MAX	UNIT
V_{IH} High-level input voltage		2			V
V_{IL} Low-level input voltage			0.8		V
V_{IK} Input clamp voltage	$V_{CC} = \text{MIN}$, $I_I = -12 \text{ mA}$			-1.5	V
I_{OH} High-level output current	$V_{CC} = \text{MIN}$, $V_{IH} = 2 \text{ V}$, $V_{IL} = 0.8 \text{ V}$, $V_{OH} = 5.5 \text{ V}$			100	μA
V_{OL} Low-level output voltage	$V_{CC} = \text{MIN}$, $V_{IH} = 2 \text{ V}$, $V_{IL} = 0.8 \text{ V}$, $I_{OL} = 12 \text{ mA}$			0.4	V
I_I Input current at maximum input voltage	$V_{CC} = \text{MAX}$, $V_I = 5.5 \text{ V}$			1	mA
I_{IH} High-level input current	$V_{CC} = \text{MAX}$, $V_I = 2.4 \text{ V}$			40	μA
I_{IL} Low-level input current	$V_{CC} = \text{MAX}$, $V_I = 0.4 \text{ V}$			-1	mA
I_{CCH} Supply current, all outputs high	$V_{CC} = \text{MAX}$		50		mA
I_{CCL} Supply current, all programmed outputs low			62	99	

[†] For conditions shown as MIN or MAX, use the appropriate value specified under recommended operating conditions for the applicable type.

[‡] All typical values are at $V_{CC} = 5 \text{ V}$, $T_A = 25^\circ\text{C}$.

switching characteristics, $V_{CC} = 5 \text{ V}$, $T_A = 25^\circ\text{C}$

PARAMETER	TEST CONDITIONS	MIN	TYP	MAX	UNIT	
t_{PLH} Propagation delay time, low-to-high-level output from enable \bar{G}	$C_L = 30 \text{ pF}$, $R_{L1} = 300 \Omega$, $R_{L2} = 600 \Omega$, See Figure 1 and Note 2		19	30	ns	
t_{PHL} Propagation delay time, high-to-low-level output from enable \bar{G}			22	35	ns	
t_{PLH} Propagation delay time, low-to-high-level output from binary select				27	40	ns
t_{PHL} Propagation delay time, high-to-low-level output from binary select				23	40	ns

3 TTL DEVICES

TYPES SN54184, SN54185A, SN74184, SN74185A BCD-TO-BINARY AND BINARY-TO-BCD CONVERTERS

schematics of inputs and outputs

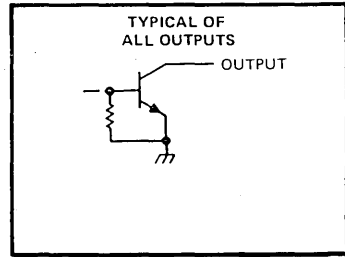
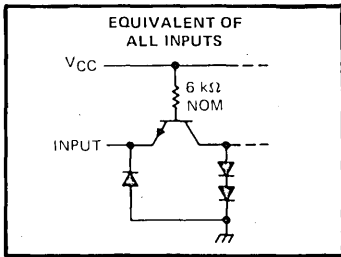

PARAMETER MEASUREMENT INFORMATION

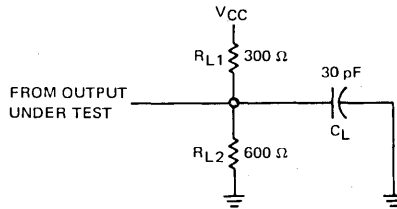

C_L includes probe and jig capacitance.

LOAD CIRCUIT
FIGURE 1

NOTE 2: See General Information Section for load circuits and voltage waveforms.

TYPES SN54184, SN74184
BCD-TO-BINARY CONVERTERS

TYPICAL APPLICATION DATA
SN54184, SN74184

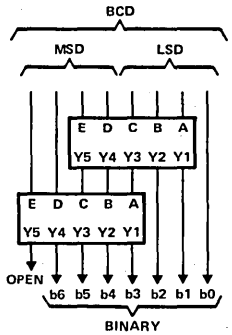

FIGURE 2—BCD-TO-BINARY CONVERTER FOR TWO BCD DECADES

MSD—most significant decade
 LSD—least significant decade
 Each rectangle represents an SN54184 or SN74184

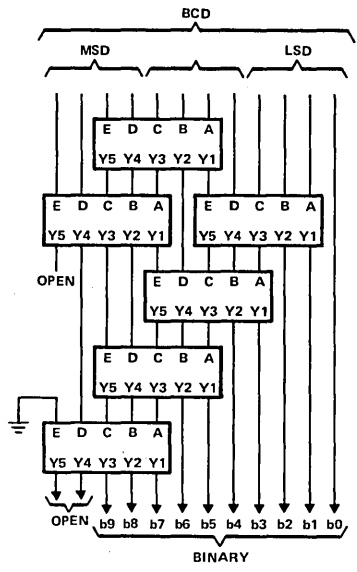

FIGURE 3—BCD-TO-BINARY CONVERTER FOR THREE BCD DECADES

3
TTL DEVICES

**TYPES SN54185A, SN74185A
BINARY-TO-BCD CONVERTERS**

**TYPICAL APPLICATION DATA
SN54185A, SN74185A**

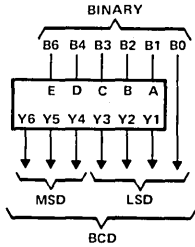

FIGURE 5—6-BIT BINARY-TO-BCD CONVERTER

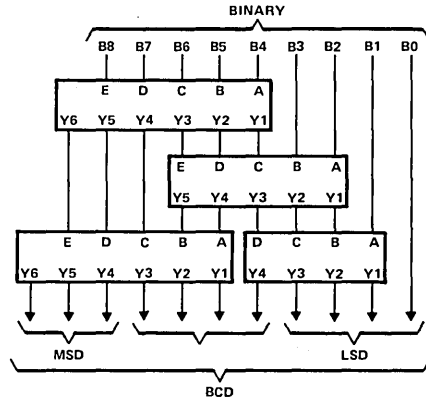

FIGURE 7—9-BIT BINARY-TO-BCD CONVERTER

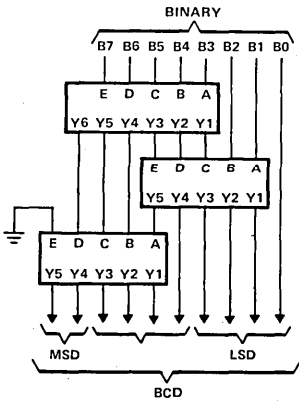

FIGURE 6—8-BIT BINARY-TO-BCD CONVERTER

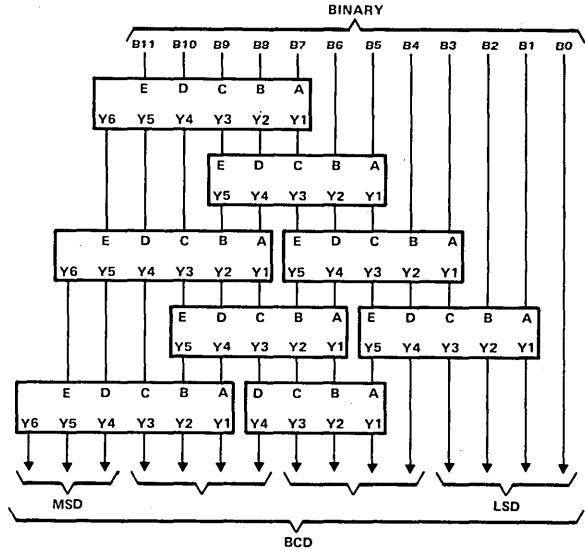

FIGURE 8—12-BIT BINARY-TO-BCD CONVERTER (SEE NOTE B)

MSD—Most significant decade

LSD—Least significant decade

NOTES: A. Each rectangle represents an SN54185A or an SN74185A.

B. All unused E inputs are grounded.

TYPES SN54185A, SN74185A
BINARY-TO-BCD CONVERTERS

TYPICAL APPLICATION DATA
SN54185A, SN74185A

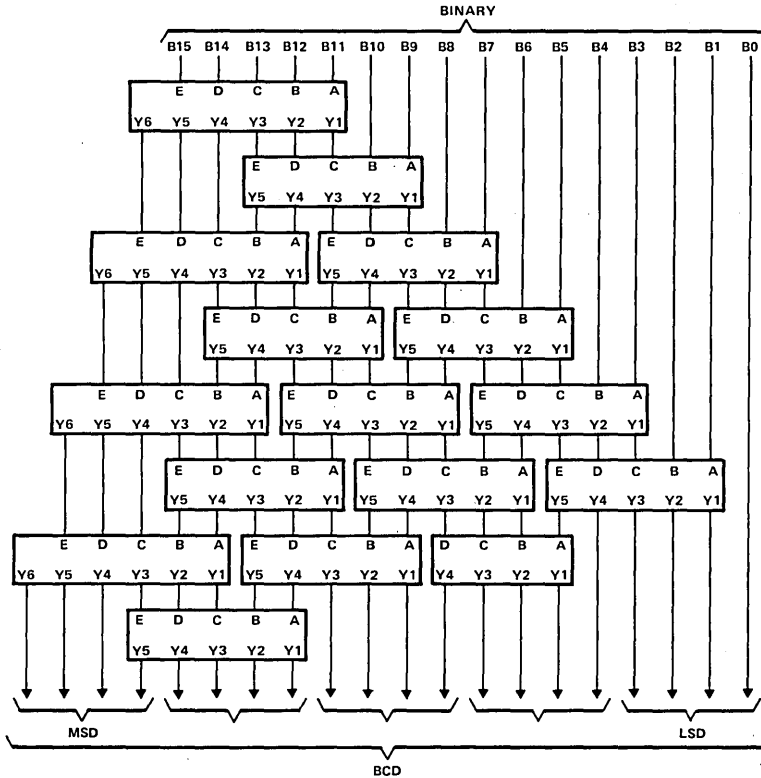

FIGURE 9—16 BIT BINARY-TO-BCD
CONVERTER (SEE NOTE B)

MSD—most significant decade

LSD—least significant decade

NOTES: A. Each rectangle represents an SN54185A or SN74185A.

B. All unused E inputs are grounded.

TYPES SN54190, SN54191, SN54LS190, SN54LS191, SN74190, SN74191, SN74LS190, SN74LS191 SYNCHRONOUS UP/DOWN COUNTERS WITH DOWN/UP MODE CONTROL

DECEMBER 1972—REVISED DECEMBER 1983

- Counts 8-4-2-1 BCD or Binary
- Single Down/Up Count Control Line
- Count Enable Control Input
- Ripple Clock Output for Cascading
- Asynchronously Presetable with Load Control
- Parallel Outputs
- Cascadable for n-Bit Applications

SN54190, SN54191, SN54LS190,
SN54LS191 ... J OR W PACKAGE
SN74190, SN74191 ... J OR N PACKAGE
SN74LS190, SN74LS191 ... D, J OR N PACKAGE
(TOP VIEW)

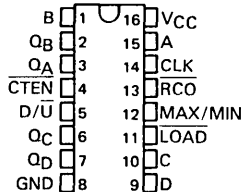

SN54LS190, SN54LS191 ... FK PACKAGE
SN74LS190, SN74LS191 ... FN PACKAGE
(TOP VIEW)

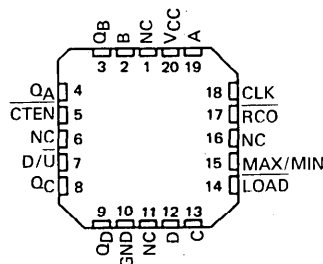

NC - No internal connection

TYPE	TYPICAL		
	AVERAGE PROPAGATION DELAY	MAXIMUM CLOCK FREQUENCY	TYPICAL POWER DISSIPATION
'190, '191	20ns	25MHz	325mW
'LS190, 'LS191	20ns	25MHz	100mW

description

The '190, 'LS190, '191, and 'LS191 are synchronous, reversible up/down counters having a complexity of 58 equivalent gates. The '191 and 'LS191 are 4-bit binary counters and the '190 and 'LS190 are BCD counters. Synchronous operation is provided by having all flip-flops clocked simultaneously so that the outputs change coincident with each other when so instructed by the steering logic. This mode of operation eliminates the output counting spikes normally associated with asynchronous (ripple clock) counters.

The outputs of the four master-slave flip-flops are triggered on a low-to-high transition of the clock input if the enable input is low. A high at the enable input inhibits counting. Level changes at the enable input should be made only when the clock input is high. The direction of the count is determined by the level of the down/up input. When low, the counter count up and when high, it counts down. A false clock may occur if the down/up input changes while the clock is low. A false ripple carry may occur if both the clock and enable are low and the down/up input is high during a load pulse.

These counters are fully programmable; that is, the outputs may be preset to either level by placing a low on the load input and entering the desired data at the data inputs. The output will change to agree with the data inputs independently of the level of the clock input. This feature allows the counters to be used as modulo-N dividers by simply modifying the count length with the preset inputs.

The clock, down/up, and load inputs are buffered to lower the drive requirement which significantly reduces the number of clock drivers, etc., required for long parallel words.

Two outputs have been made available to perform the cascading function: ripple clock and maximum/minimum count. The latter output produces a high-level output pulse with a duration approximately equal to one complete cycle of the clock when the counter overflows or underflows. The ripple clock output produces a low-level output pulse equal in width to the low-level portion of the clock input when an overflow or underflow condition exists. The counters can be easily cascaded by feeding the ripple clock output to the enable input of the succeeding counter if parallel clocking is used, or to the clock input if parallel enabling is used. The maximum/minimum count output can be used to accomplish look-ahead for high-speed operation.

Series 54' and 54LS' are characterized for operation over the full military temperature range of -55°C to 125°C ; Series 74' and 74LS' are characterized for operation from 0°C to 70°C .

PRODUCTION DATA
This document contains information current as of publication date. Products conform to specifications per the terms of Texas Instruments standard warranty. Production processing does not necessarily include testing of all parameters.

**TEXAS
INSTRUMENTS**

POST OFFICE BOX 225012 • DALLAS, TEXAS 75265

3-741

TYPES SN54190, SN54191, SN54LS190, SN54LS191
 SN74190, SN74191, SN74LS190, SN74LS191
 SYNCHRONOUS UP/DOWN COUNTERS WITH DOWN/UP MODE CONTROL

logic symbols

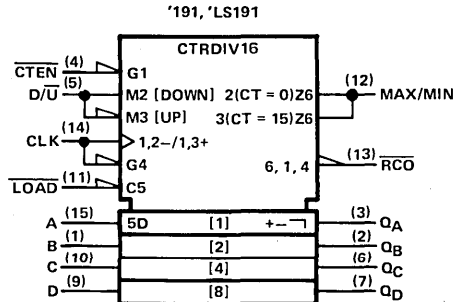
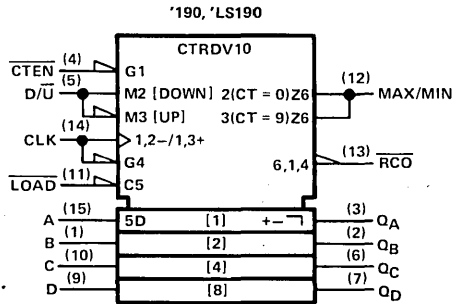

Pin numbers shown on logic notation are for D, J or N packages.



TTL DEVICES

TYPES SN54190, SN54LS190, SN74190, SN74LS190 SYNCHRONOUS UP/DOWN COUNTERS WITH DOWN/UP MODE CONTROL

logic diagram

'190, 'LS190 DECADE COUNTERS

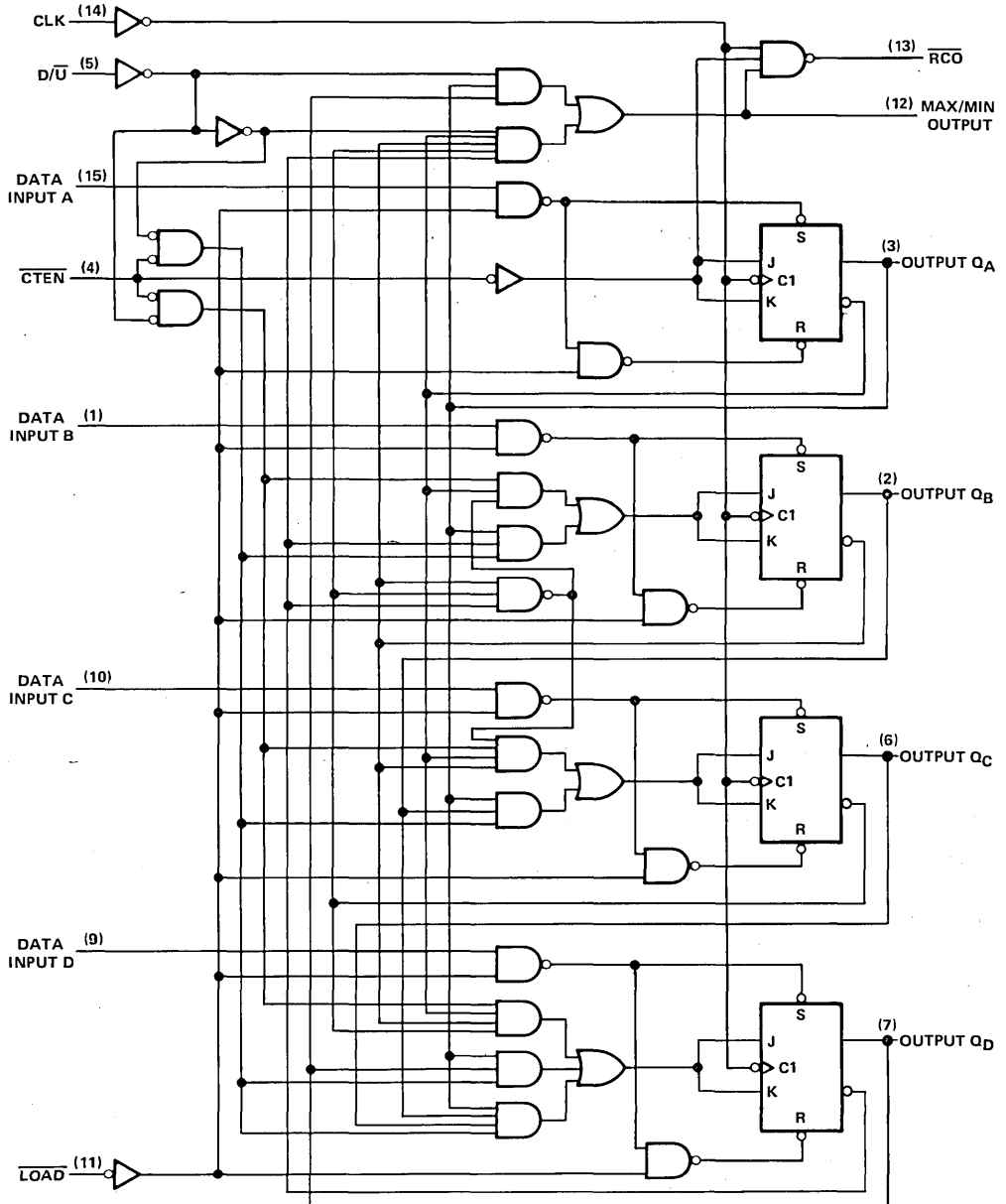

Pin numbers shown on logic notation are for D, J or N packages.

3

TTL DEVICES

**TEXAS
INSTRUMENTS**

POST OFFICE BOX 225012 • DALLAS, TEXAS 75265

3-743

TYPES SN54191, SN54LS191, SN74191, SN74LS191
SYNCHRONOUS UP/DOWN COUNTERS WITH DOWN/UP MODE CONTROL

logic diagram

'191, 'LS191 BINARY COUNTERS

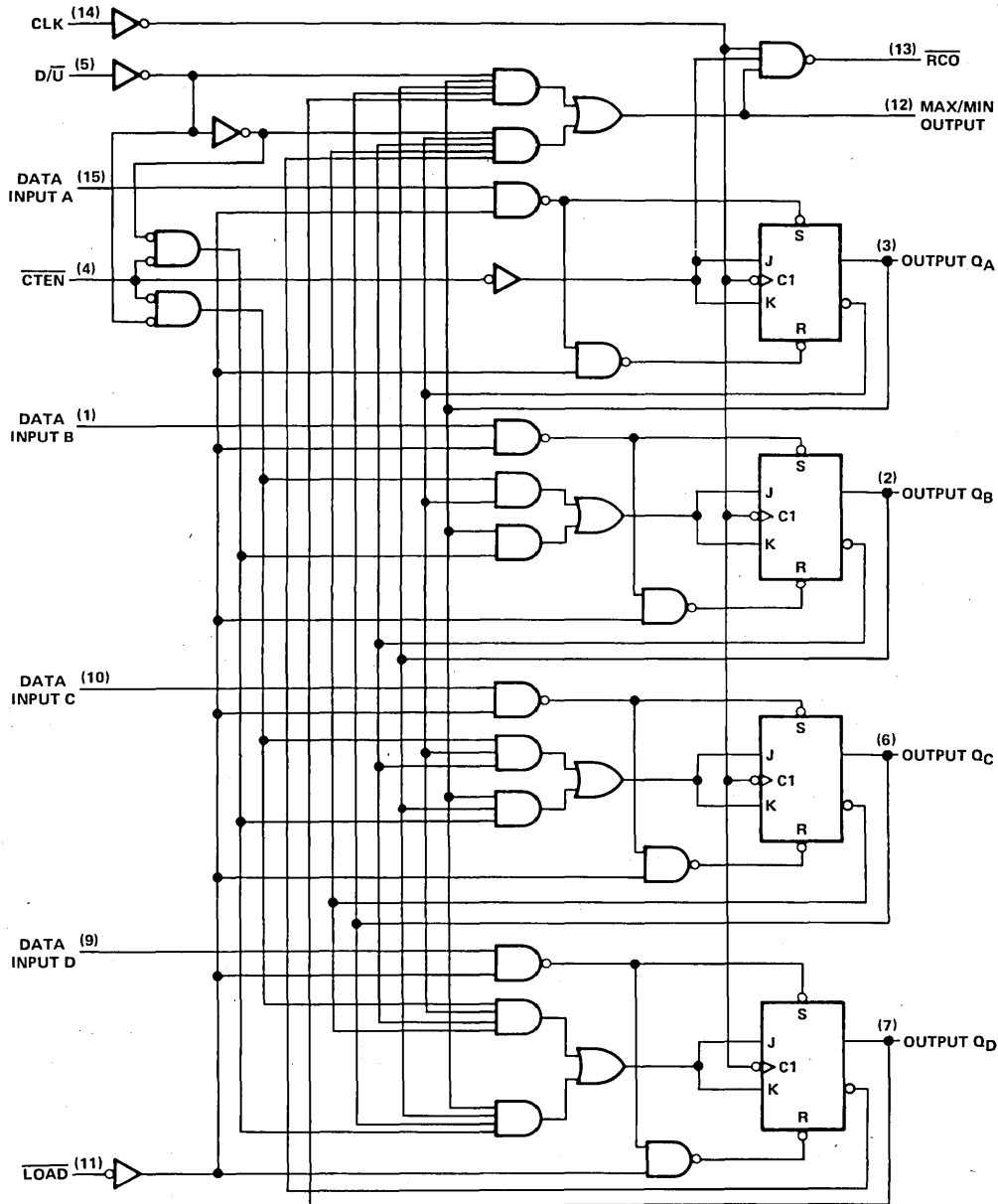

Pin numbers shown on logic notation are for D, J or N packages.

3

TTL DEVICES

TYPES SN54190, SN54LS190, SN74190, SN74LS190 SYNCHRONOUS UP/DOWN COUNTERS WITH DOWN/UP MODE CONTROL

'190, 'LS190 DECADE COUNTERS

typical load, count, and inhibit sequences

Illustrated below is the following sequence:

1. Load (preset) to BCD seven.
2. Count up to eight, nine (maximum), zero, one, and two.
3. Inhibit.
4. Count down to one, zero (minimum), nine, eight, and seven.

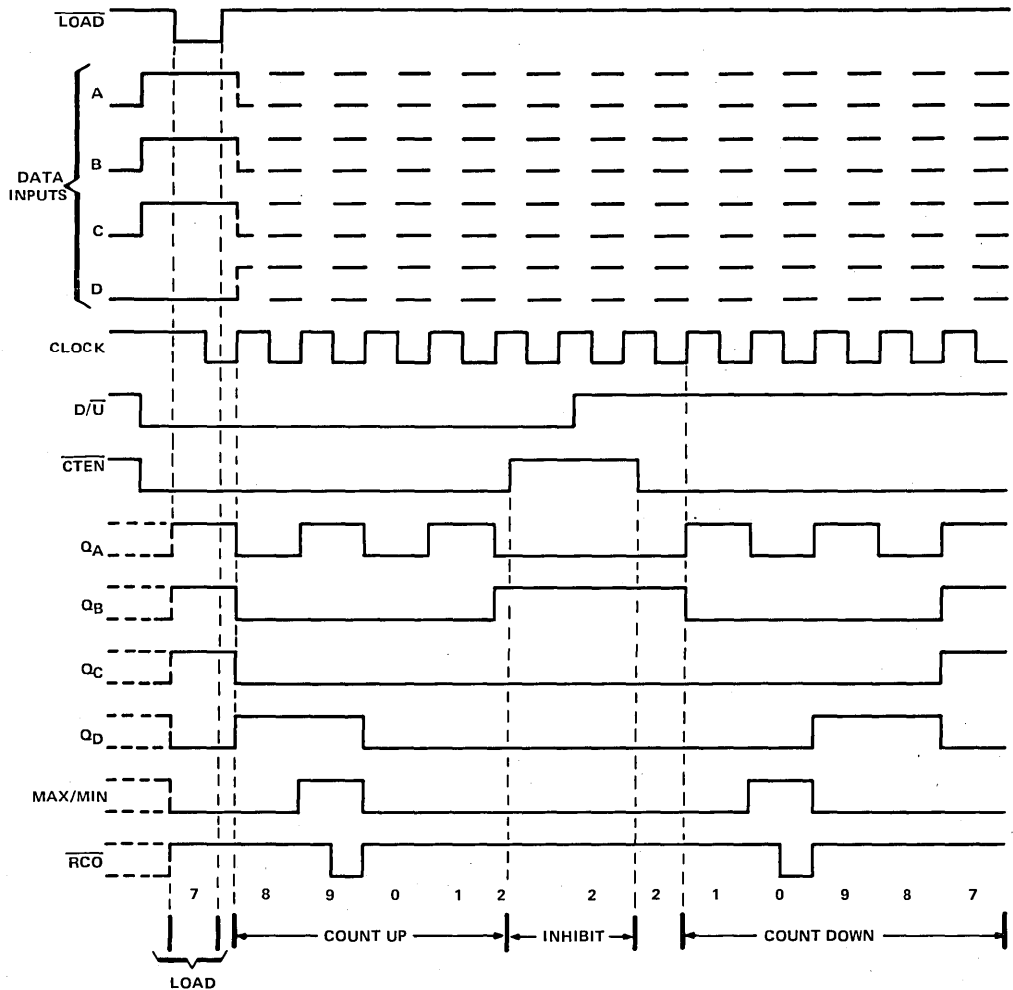

3
TTL DEVICES

TYPES SN54191, SN54LS191, SN74191, SN74LS191
SYNCHRONOUS UP/DOWN COUNTERS WITH DOWN/UP MODE CONTROL

'191, 'LS191 BINARY COUNTERS

typical load, count, and inhibit sequences

Illustrated below is the following sequence:

1. Load (preset) to binary thirteen.
2. Count up to fourteen, fifteen (maximum), zero, one, and two.
3. Inhibit.
4. Count down to one, zero (minimum), fifteen, fourteen, and thirteen.

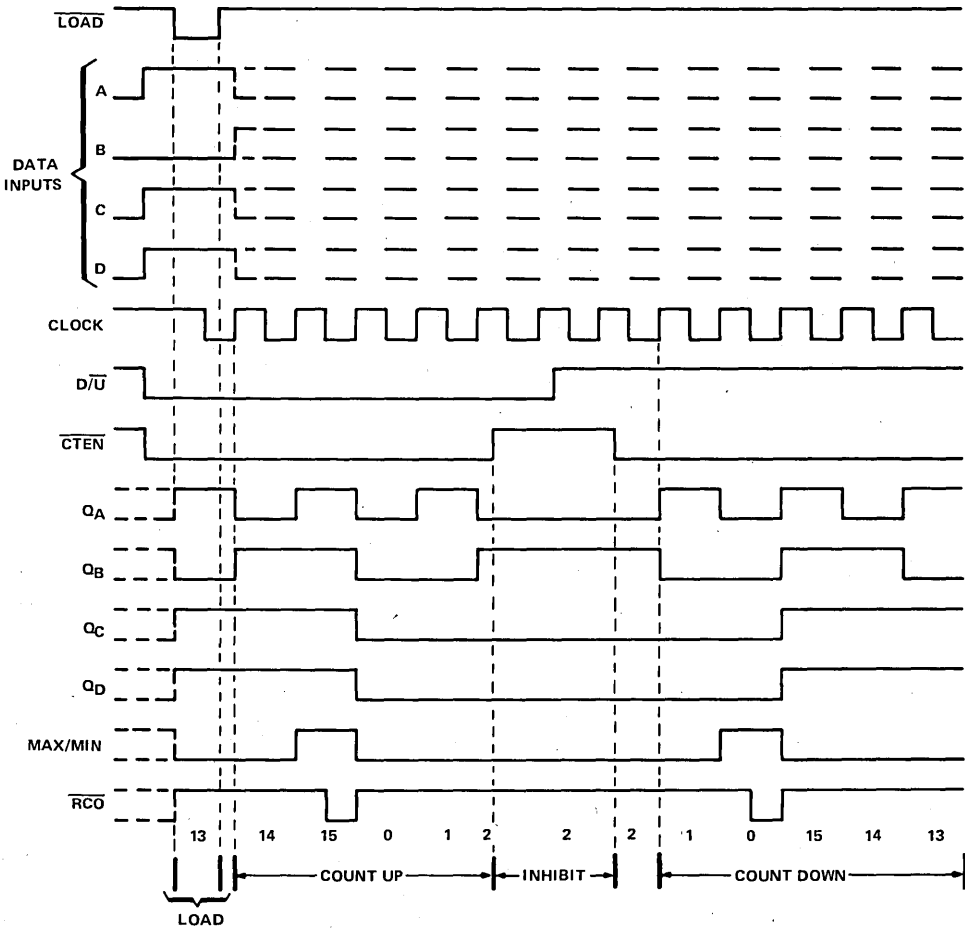

TYPES SN54190, SN54191, SN54LS190, SN54LS191, SN74190, SN74191, SN74LS190, SN74LS191 SYNCHRONOUS UP/DOWN COUNTERS WITH DOWN/UP MODE CONTROL

absolute maximum ratings over operating free-air temperature range (unless otherwise noted)

Supply voltage, V_{CC} (see Note 1)	7 V
Input voltage: SN54 [†] , SN74 [†] Circuits	5.5 V
SN54LS [†] , SN74LS [†] Circuits	7 V
Operating free-air temperature range: SN54 [†] , SN54LS [†] Circuits	-55°C to 125°C
SN74 [†] , SN74LS [†] Circuits	0°C to 70°C
Storage temperature range	-65°C to 150°C

NOTE 1: Voltage values are with respect to network ground terminal.

recommended operating conditions

		SN54190, SN54191			SN74190, SN74191			UNIT
		MIN	NOM	MAX	MIN	NOM	MAX	
V_{CC}	Supply voltage	4.5	5	5.5	4.75	5	5.25	V
I_{OH}	High-level output current	-0.8			-0.8			mA
I_{OL}	Low-level output current	16			16			mA
f_{clock}	Input clock frequency	0	20		0	20		MHz
$t_{w(clock)}$	Width of clock input pulse	25			25			ns
$t_{w(load)}$	Width of load input pulse	35			35			ns
t_{su}	Setup time	Data, high or low (See Figure 1 and 2)			20			ns
		Load inactive state			20			
t_{hold}	Data hold time	0			0			ns
T_A	Operating free-air temperature	-55	125		0	70		°C

electrical characteristics over recommended operating free-air temperature range (unless otherwise noted)

PARAMETER	TEST CONDITIONS [†]	SN54190, SN54191			SN74190, SN74191			UNIT	
		MIN	TYP [‡]	MAX	MIN	TYP [‡]	MAX		
V_{IH}	High-level input voltage	$V_{CC} = \text{MIN}$			2			V	
V_{IL}	Low-level input voltage	$V_{CC} = \text{MIN}$			0.8			V	
V_{IK}	Input clamp voltage	$V_{CC} = \text{MIN}, I_I = -12 \text{ mA}$			-1.5			V	
V_{OH}	High-level output voltage	2.4	3.4		2.4	3.4		V	
V_{OL}	Low-level output voltage	0.2	0.4		0.2	0.4		V	
I_I	High-level input current at maximum input voltage	$V_{CC} = \text{MAX}, V_I = 5.5 \text{ V}$			1			mA	
I_{IH}	High-level input current at any input except enable	$V_{CC} = \text{MAX}, V_I = 2.4 \text{ V}$			40			μA	
I_{IH}	High-level input current at enable input	$V_{CC} = \text{MAX}, V_I = 2.4 \text{ V}$			120			μA	
I_{IL}	Low-level input current at any input except enable	$V_{CC} = \text{MAX}, V_I = 0.4 \text{ V}$			-1.6			mA	
I_{IL}	Low-level input current at enable input	$V_{CC} = \text{MAX}, V_I = 0.4 \text{ V}$			-4.8			mA	
I_{OS}	Short-circuit output current [§]	$V_{CC} = \text{MAX}$			-20	-65	-18	-65	mA
I_{CC}	Supply current	$V_{CC} = \text{MAX},$ See Note 2			65	99	65	105	mA

[†] For conditions shown as MAX or MIN, use appropriate value specified under recommended operating conditions.

[‡] All typical values are at $V_{CC} = 5 \text{ V}, T_A = 25^\circ \text{C}$.

[§] Not more than one output should be shorted at a time.

NOTE 2: I_{CC} is measured with all inputs grounded and all outputs open.

3
TTL DEVICES

TYPES SN54190, SN54191, SN74190, SN74191 SYNCHRONOUS UP/DOWN COUNTERS WITH DOWN/UP MODE CONTROL

switching characteristics, $V_{CC} = 5\text{ V}$, $T_A = 25^\circ\text{C}$

PARAMETER †	FROM (INPUT)	TO (OUTPUT)	TEST CONDITIONS	'190, '191			UNIT
				MIN	TYP	MAX	
f_{max}			$C_L = 15\text{ pF}$, $R_L = 400\ \Omega$, See Figures 1 and 3 thru 7	20	25		MHz
t_{PLH}	Load	Q_A, Q_B, Q_C, Q_D			22	33	ns
t_{PHL}					33	50	
t_{PLH}	Data A, B, C, D	Q_A, Q_B, Q_C, Q_D			14	22	ns
t_{PHL}					35	50	
t_{PLH}	CLK	\overline{RCO}			13	20	ns
t_{PHL}					16	24	
t_{PLH}	CLK	Q_A, Q_B, Q_C, Q_D			16	24	ns
t_{PHL}					24	36	
t_{PLH}	CLK	Max/Min			28	42	ns
t_{PHL}					37	52	
t_{PLH}	D/\overline{U}	\overline{RCO}			30	45	ns
t_{PHL}					30	45	
t_{PLH}	D/\overline{U}	Max/Min			21	33	ns
t_{PHL}					22	33	

† f_{max} ≡ maximum clock frequency

t_{PLH} ≡ propagation delay time, low-to-high-level output

t_{PHL} ≡ propagation delay time, high-to-low-level output

schematics of inputs and outputs

EQUIVALENT OF EACH INPUT

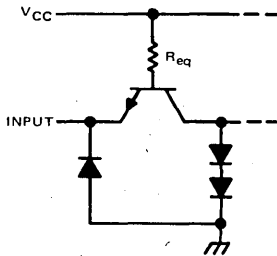

Enable input: $R_{eq} = 1.3\text{ k}\Omega\text{ NOM}$
All other inputs: $R_{eq} = 4\text{ k}\Omega\text{ NOM}$

TYPICAL OF ALL OUTPUTS

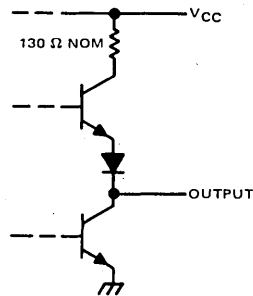

3 TTL DEVICES

TYPES SN54LS190, SN54LS191, SN74LS190, SN74LS191 SYNCHRONOUS UP/DOWN COUNTERS WITH DOWN/UP MODE CONTROL

recommended operating conditions

		SN54LS190 SN54LS191			SN74LS190 SN74LS191			UNIT
		MIN	NOM	MAX	MIN	NOM	MAX	
V _{CC}	Supply voltage	4.5	5	5.5	4.75	5	5.25	V
I _{OH}	High-level output current	-0.4			-0.4			mA
I _{OL}	Low-level output current	4			8			mA
f _{clock}	Clock frequency	0			20			MHz
t _{w(clock)}	Width of clock input pulse	25			25			ns
t _{w(load)}	Width of load input pulse	35			35			ns
t _{su}	Data setup time (See Figures 1 and 2)	20			20			ns
t _{su}	Load inactive state setup time	30			30			ns
t _h	Data hold time	5			5			ns
t _h	Enable hold time	0			0			ns
t _{enable}	Count enable time (see Note 3)	40			40			ns
T _A	Operating free-air temperature	-55			125			°C

electrical characteristics over recommended operating free-air temperature range (unless otherwise noted)

PARAMETER		TEST CONDITIONS†	SN54LS190 SN54LS191			SN74LS190 SN74LS191			UNIT	
			MIN	TYP‡	MAX	MIN	TYP‡	MAX		
V _{IH}	High-level input voltage		2			2			V	
V _{IL}	Low-level input voltage		0.7			0.8			V	
V _{IK}	Input clamp voltage	V _{CC} = MIN, I _I = -18 mA	-1.5			-1.5			V	
V _{OH}	High-level output voltage	V _{CC} = MIN, V _{IH} = 2 V, V _{IL} = V _{IL max} , I _{OH} = -400 μA	2.5	3.4		2.7	3.4		V	
V _{OL}	Low-level output voltage	V _{CC} = MIN, V _{IH} = 2 V, V _{IL} = V _{IL max}	I _{OL} = 4 mA I _{OL} = 8 mA		0.25	0.4	0.25	0.4	V	
I _I	High-level input current at maximum input voltage	Enable	V _{CC} = MAX, V _I = 7 V			0.3			mA	
		Others				0.1				
I _{IH}	High-level input current	Enable	V _{CC} = MAX, V _I = 2.7 V			60			μA	
		Others				20				
I _{IL}	Low-level input current	Enable	V _{CC} = MAX, V _I = 0.4 V			-1.2			mA	
		Others				-0.4				
I _{OS}	Short-circuit output current§	V _{CC} = MAX,	-20	-100	-20	-100		mA		
I _{CC}	Supply current	V _{CC} = MAX, See Note 2	20		35		20		35	mA

† For conditions shown as MAX or MIN, use appropriate value specified under recommended operating conditions for the applicable device type.

‡ All typical values are at V_{CC} = 5 V, T_A = 25°C.

§ Not more than one output should be shorted at a time, and duration of the short-circuit should not exceed one second.

NOTES: 2. I_{CC} is measured with all inputs grounded and all outputs open.

3. Minimum count enable time is the interval immediately preceding the rising edge of the clock pulse during which interval the count enable input must be low to ensure counting.

3

TTL DEVICES

TYPES SN54LS190, SN54LS191, SN74LS190, SN74LS191 SYNCHRONOUS UP/DOWN COUNTERS WITH DOWN/UP MODE CONTROL

switching characteristics, $V_{CC} = 5\text{ V}$, $T_A = 25^\circ\text{C}$

PARAMETER ¹	FROM (INPUT)	TO (OUTPUT)	TEST CONDITIONS	'LS190, 'LS191			UNIT
				MIN	TYP	MAX	
f_{max}			$C_L = 15\text{ pF}$, $R_L = 2\text{ k}\Omega$, See Figures 1 and 3 thru 7	20	25	32	MHz
t_{PLH}	Load	Q_A, Q_B, Q_C, Q_D		22	33	ns	
t_{PHL}				33	50		
t_{PLH}	Data A, B, C, D	Q_A, Q_B, Q_C, Q_D		20	32	ns	
t_{PHL}				27	40		
t_{PLH}	CLK	\overline{RCO}		13	20	ns	
t_{PHL}				16	24		
t_{PLH}	CLK	Q_A, Q_B, Q_C, Q_D		16	24	ns	
t_{PHL}				24	36		
t_{PLH}	CLK	Max/Min		28	42	ns	
t_{PHL}				37	52		
t_{PLH}	D/\overline{U}	\overline{RCO}		30	45	ns	
t_{PHL}				30	45		
t_{PLH}	D/\overline{U}	Max/Min		21	33	ns	
t_{PHL}				22	33		
t_{PLH}	\overline{CTEN}	\overline{RCO}		21	33	ns	
t_{PHL}			22	33			

¹ f_{max} = maximum clock frequency
 t_{PLH} = propagation delay time, low-to-high-level output
 t_{PHL} = propagation delay time, high-to-low-level output

schematics of inputs and outputs

EQUIVALENT OF EACH INPUT

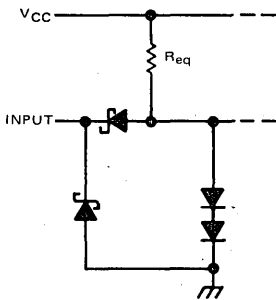

Enable input: $R_{eq} = 8.33\text{ k}\Omega\text{ NOM}$
 Load input: $R_{eq} = 25\text{ k}\Omega\text{ NOM}$
 All other inputs: $R_{eq} = 17\text{ k}\Omega\text{ NOM}$

TYPICAL OF ALL OUTPUTS

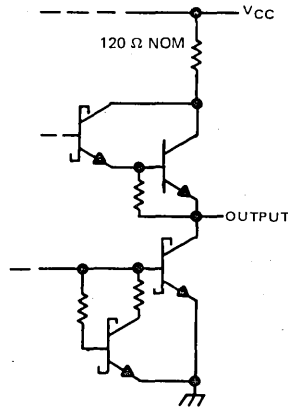

**TYPES SN54190, SN54191, SN54LS190, SN54LS191,
SN74190, SN74191, SN74LS190, SN74LS191**
SYNCHRONOUS UP/DOWN COUNTERS WITH DOWN/UP MODE CONTROL

PARAMETER MEASUREMENT INFORMATION

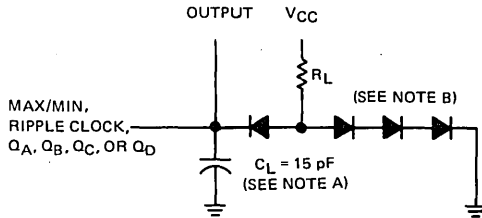

**FIGURE 1—LOAD CIRCUIT
FOR SWITCHING TIME MEASUREMENT**

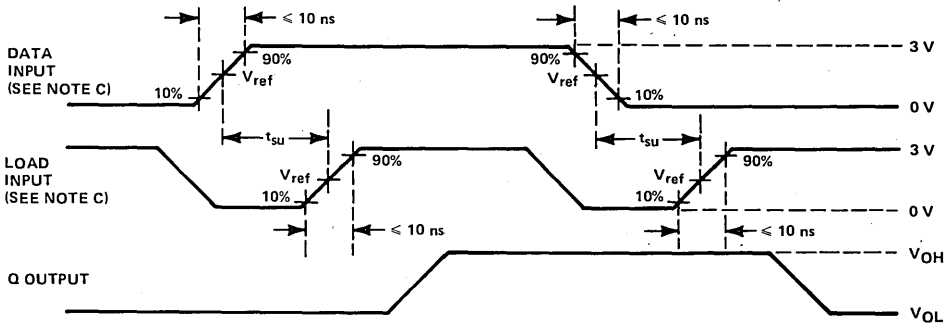
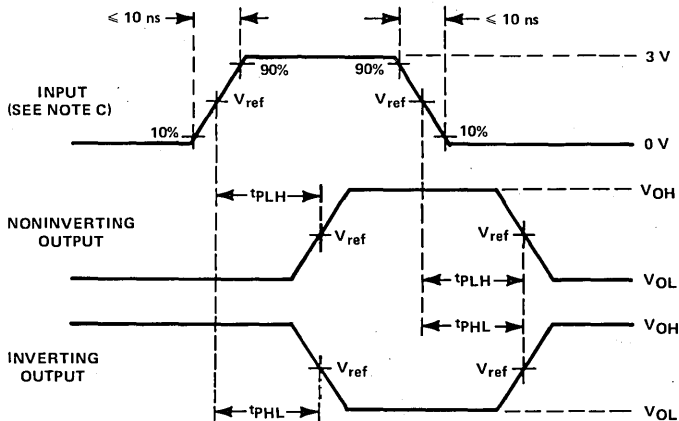

FIGURE 2—DATA SETUP TIME VOLTAGE WAVEFORMS



See waveform sequences in figures 4 through 7 for propagation times from a specific input to a specific output. For simplification, pulse rise times, reference levels, etc., have not been shown in figures 4 through 7.

FIGURE 3—GENERAL VOLTAGE WAVEFORMS FOR PROPAGATION TIMES

- NOTES: A. C_L includes probe and jig capacitance.
 B. All diodes are 1N3064 or equivalent.
 C. The input pulses are supplied by generators having the following characteristics: $Z_{out} = 50\ \Omega$, duty cycle $\leq 50\%$, PRR $\leq 1\text{ MHz}$.
 D. $V_{ref} = 1.5\text{ V}$ for '190 and '191; 1.3 V for 'LS190 and 'LS191.

TYPES SN54190, SN54191, SN54LS190, SN54LS191,
 SN74190, SN74191, SN74LS190, SN74LS191
 SYNCHRONOUS UP/DOWN COUNTERS WITH DOWN/UP MODE CONTROL

PARAMETER MEASUREMENT INFORMATION (continued)

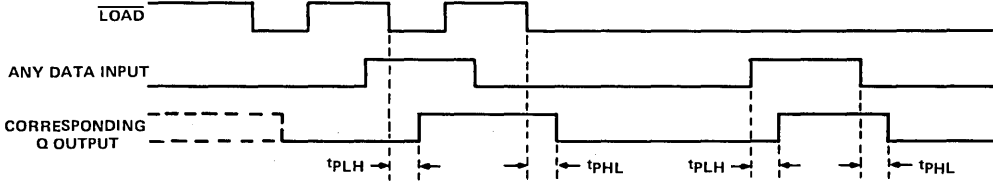

NOTE E: Conditions on other inputs are irrelevant.

FIGURE 4—LOAD TO OUTPUT AND DATA TO OUTPUT

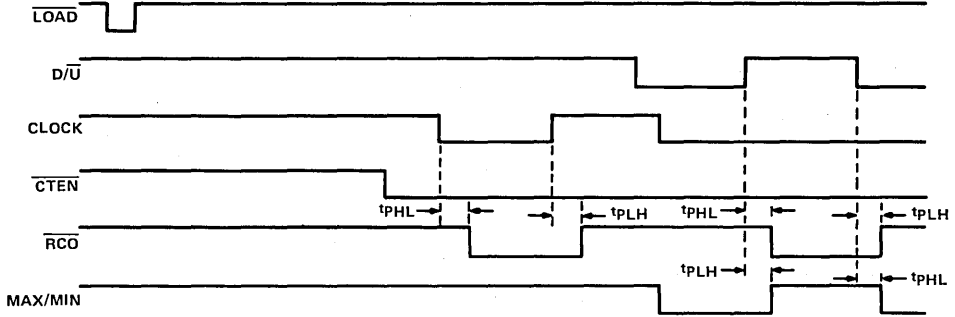

NOTE F: All data inputs are low.

FIGURE 5—ENABLE TO RIPPLE CLOCK, CLOCK TO RIPPLE CLOCK, DOWN/UP TO RIPPLE CLOCK, AND DOWN/UP TO MAX/MIN

3

TTL DEVICES

TYPES SN54190, SN54191, SN54LS190, SN54LS191,
SN74190, SN74191, SN74LS190, SN74LS191
SYNCHRONOUS UP/DOWN COUNTERS WITH DOWN/UP MODE CONTROL

PARAMETER MEASUREMENT INFORMATION (continued)

switching characteristics (continued)

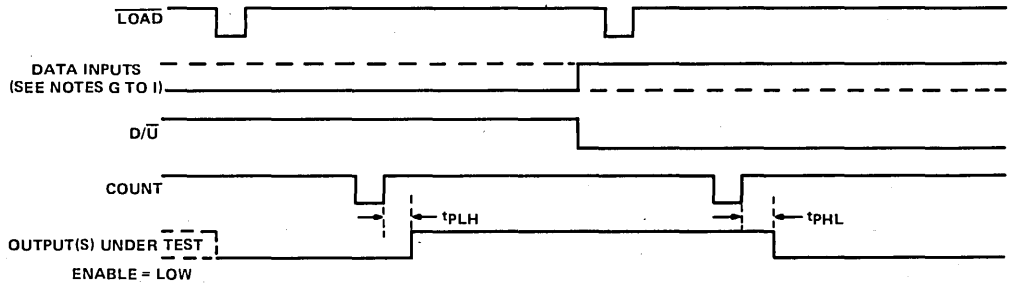

- NOTES: G. To test Q_A , Q_B , and Q_C outputs of '190 and 'LS190: Data inputs A, B, and C are shown by the solid line. Data input D is shown by the dashed line.
H. To test Q_D output of '190 and 'LS190: Data inputs A and D are shown by the solid line. Data inputs B and C are held at the low logic level.
I. To test Q_A , Q_B , Q_C , and Q_D outputs of '191 and 'LS191: All four data inputs are shown by the solid line.

FIGURE 6-CLOCK TO OUTPUT

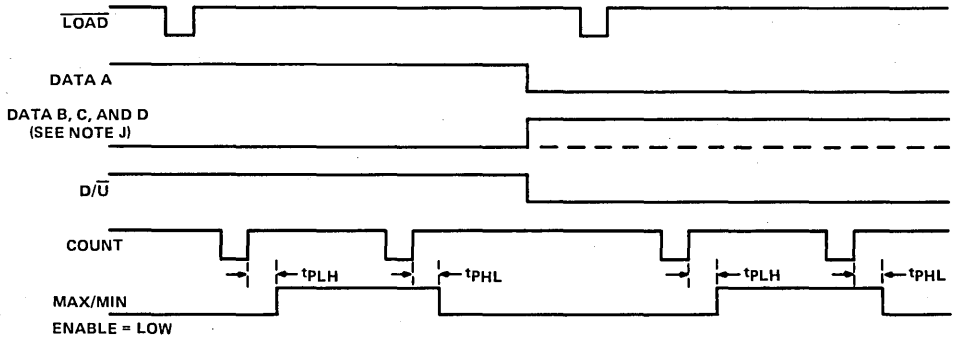

NOTE J: Data inputs B and C are shown by the dashed line for the '190 and 'LS190 and the solid line for the '191 and 'LS191: Data input D is shown by the solid line for both devices.

FIGURE 7-CLOCK TO MAX/MIN

TYPES SN54192, SN54193, SN54L192, SN54L193, SN54LS192, SN54LS193, SN74192, SN74193, SN74LS192, SN74LS193 SYNCHRONOUS 4-BIT UP/DOWN COUNTERS (DUAL CLOCK WITH CLEAR)

DECEMBER 1972—REVISED DECEMBER 1983

- Cascading Circuitry Provided Internally
- Synchronous Operation
- Individual Preset to Each Flip-Flop
- Fully Independent Clear Input

SN54192, SN54193, SN54LS192,
SN54LS193 ... J OR W PACKAGE
SN54L192, SN54L193 ... J PACKAGE
SN74192, SN74193 ... J OR N PACKAGE
SN74LS192, SN74LS193 ... D, J OR N PACKAGE

(TOP VIEW)

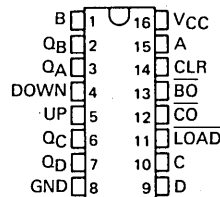

TYPES	TYPICAL MAXIMUM COUNT FREQUENCY	TYPICAL POWER DISSIPATION
'192, '193	32 MHz	325 mW
'L192, 'L193	7 MHz	43 mW
'LS192, 'LS193	32 MHz	95 mW

description

These monolithic circuits are synchronous reversible (up/down) counters having a complexity of 55 equivalent gates. The '192, 'L192, and 'LS192 circuits are BCD counters and the '193, 'L193 and 'LS193 are 4-bit binary counters. Synchronous operation is provided by having all flip-flops clocked simultaneously so that the outputs change coincidentally with each other when so instructed by the steering logic. This mode of operation eliminates the output counting spikes which are normally associated with asynchronous (ripple-clock) counters.

The outputs of the four master-slave flip-flops are triggered by a low-to-high-level transition of either count (clock) input. The direction of counting is determined by which count input is pulsed while the other count input is high.

All four counters are fully programmable; that is, each output may be preset to either level by entering the desired data at the data inputs while the load input is low. The output will change to agree with the data inputs independently of the count pulses. This feature allows the counters to be used as modulo-N dividers by simply modifying the count length with the preset inputs.

A clear input has been provided which forces all outputs to the low level when a high level is applied. The clear function is independent of the count and load inputs. The clear, count, and load inputs are buffered to lower the drive requirements. This reduces the number of clock drivers, etc., required for long words.

These counters were designed to be cascaded without the need for external circuitry. Both borrow and carry outputs are available to cascade both the up- and down-counting functions. The borrow output produces a pulse equal in width to the count-down input when the counter underflows. Similarly, the carry output produces a pulse equal in width to the count-up input when an overflow condition exists. The counters can then be easily cascaded by feeding the borrow and carry outputs to the count-down and count-up inputs respectively of the succeeding counter.

absolute maximum ratings over operating free-air temperature range (unless otherwise noted)

	SN54'	SN54L'	SN54LS'	SN74'	SN74LS'	UNIT
Supply voltage, V_{CC} (see Note 1)	7	8	7	7	7	V
Input voltage	5.5	5.5	7	5.5	7	V
Operating free-air temperature range	- 55 to 125			0 to 70		°C
Storage temperature range	- 65 to 150			- 65 to 150		°C

NOTE 1: Voltage values are with respect to network ground terminal.

PRODUCTION DATA
This document contains information current as of publication date. Products conform to specifications per the terms of Texas Instruments standard warranty. Production processing does not necessarily include testing of all parameters.

TEXAS INSTRUMENTS
POST OFFICE BOX 225012 • DALLAS, TEXAS 75265

3
TTL DEVICES

TYPES SN54192, SN54L192, SN54LS192, SN74192, SN74LS192
SYNCHRONOUS 4-BIT UP/DOWN COUNTERS (DUAL CLOCK WITH CLEAR)

logic diagram

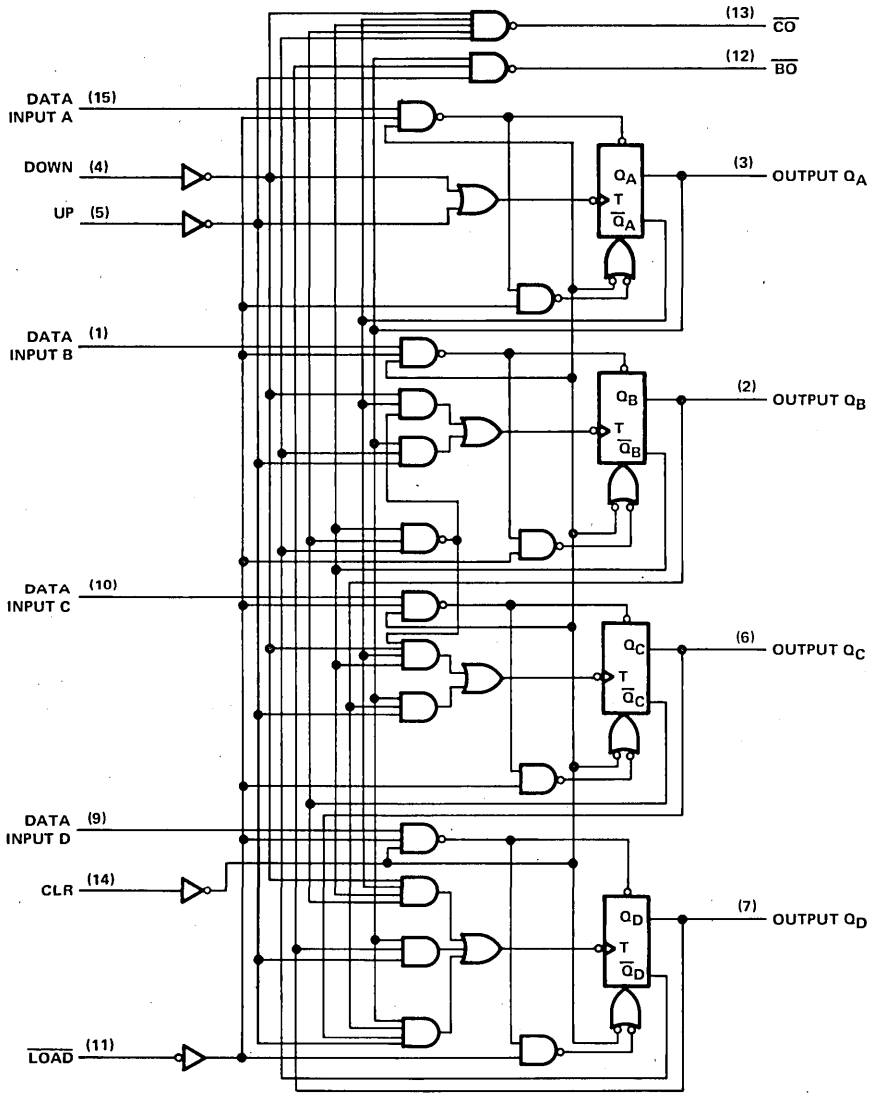

Pin numbers shown on logic notation are for D, J or N packages.

3 TTL DEVICES

TYPES SN54193, SN54L193, SN54LS193, SN74193, SN74LS193
 SYNCHRONOUS 4-BIT UP/DOWN COUNTERS (DUAL CLOCK WITH CLEAR)

logic diagram

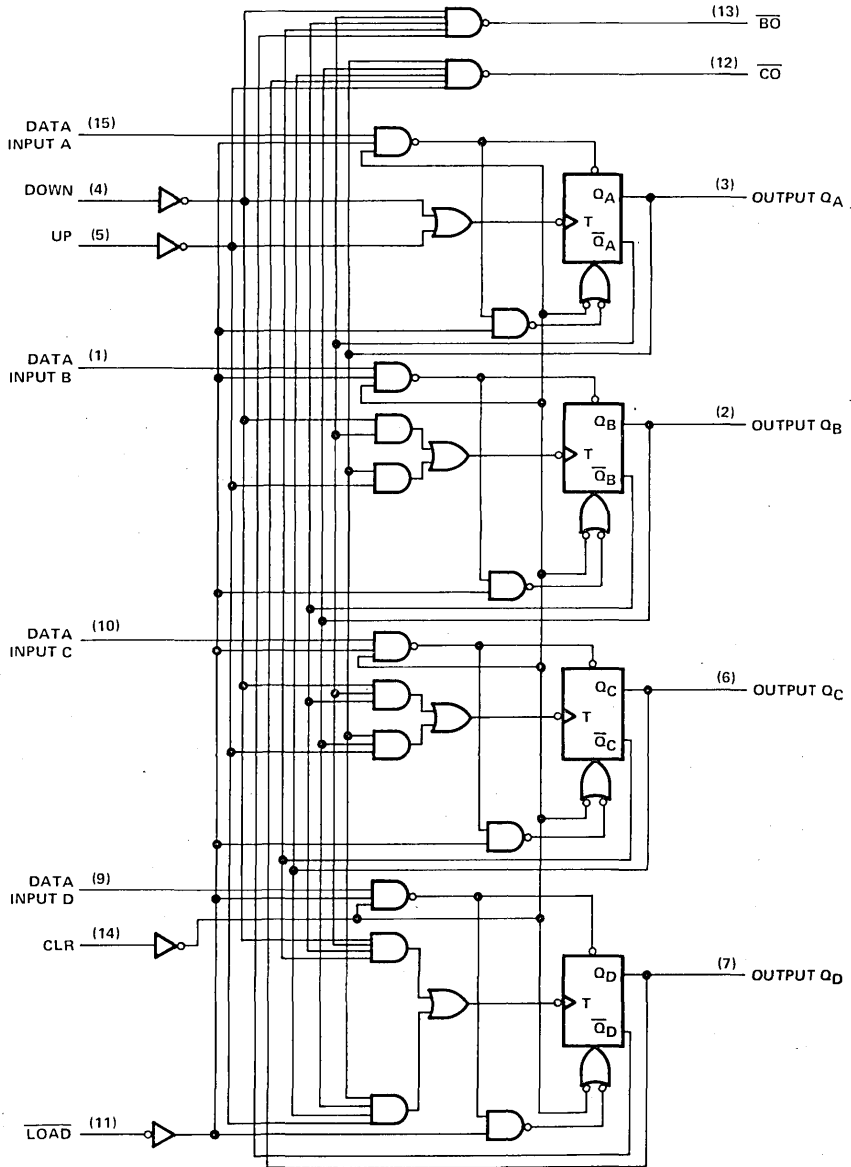

Pin numbers shown on logic notation are for D, J or N packages.



TTL DEVICES

**TYPES SN54192, SN54193, SN54L192, SN54L193, SN54LS192, SN54LS193,
SN74192, SN74193, SN74LS192, SN74LS193
SYNCHRONOUS 4-BIT UP/DOWN COUNTERS (DUAL CLOCK WITH CLEAR)**

logic symbols

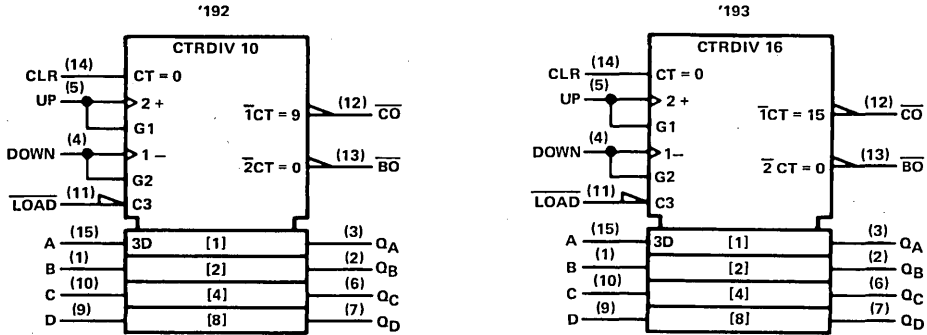

Pin numbers shown on logic notation are for D, J or N packages.

schematics of inputs and outputs

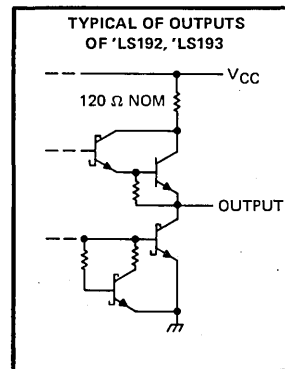
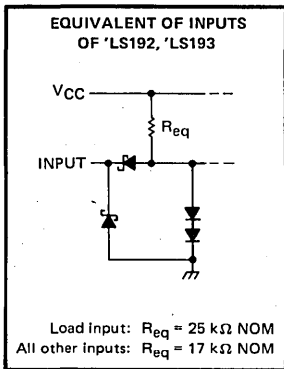
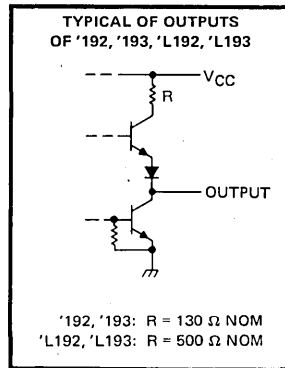
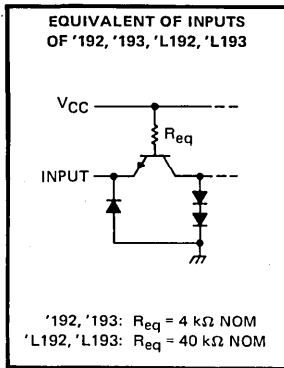

3 TTL DEVICES

TYPES SN54192, SN54L192, SN54LS192, SN74192, SN74LS192
 SYNCHRONOUS 4-BIT UP/DOWN COUNTERS (DUAL CLOCK WITH CLEAR)

'192, 'L192, 'LS192 DECADE COUNTERS

typical clear, load, and count sequences

Illustrated below is the following sequence:

1. Clear outputs to zero.
2. Load (preset) to BCD seven.
3. Count up to eight, nine, carry, zero, one, and two.
4. Count down to one, zero, borrow, nine, eight, and seven.

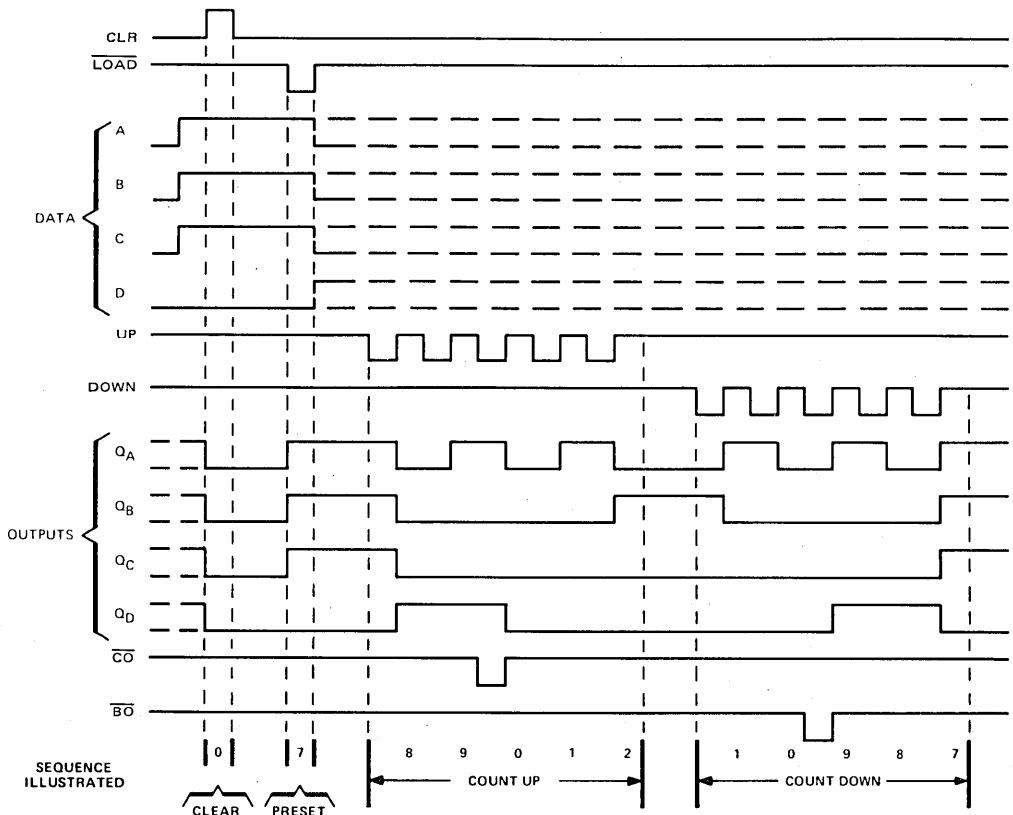

- NOTES: A. Clear overrides load, data, and count inputs.
 B. When counting up, count-down input must be high; when counting down, count-up input must be high.



TTL DEVICES

TYPES SN54193, SN54L193, SN54LS193, SN74193, SN74LS193
SYNCHRONOUS 4-BIT UP/DOWN COUNTERS (DUAL CLOCK WITH CLEAR)

'193, 'L193, 'LS193 BINARY COUNTERS

typical clear, load, and count sequences

Illustrated below is the following sequence:

1. Clear outputs to zero.
2. Load (preset) to binary thirteen.
3. Count up to fourteen, fifteen, carry, zero, one, and two.
4. Count down to one, zero, borrow, fifteen, fourteen, and thirteen.

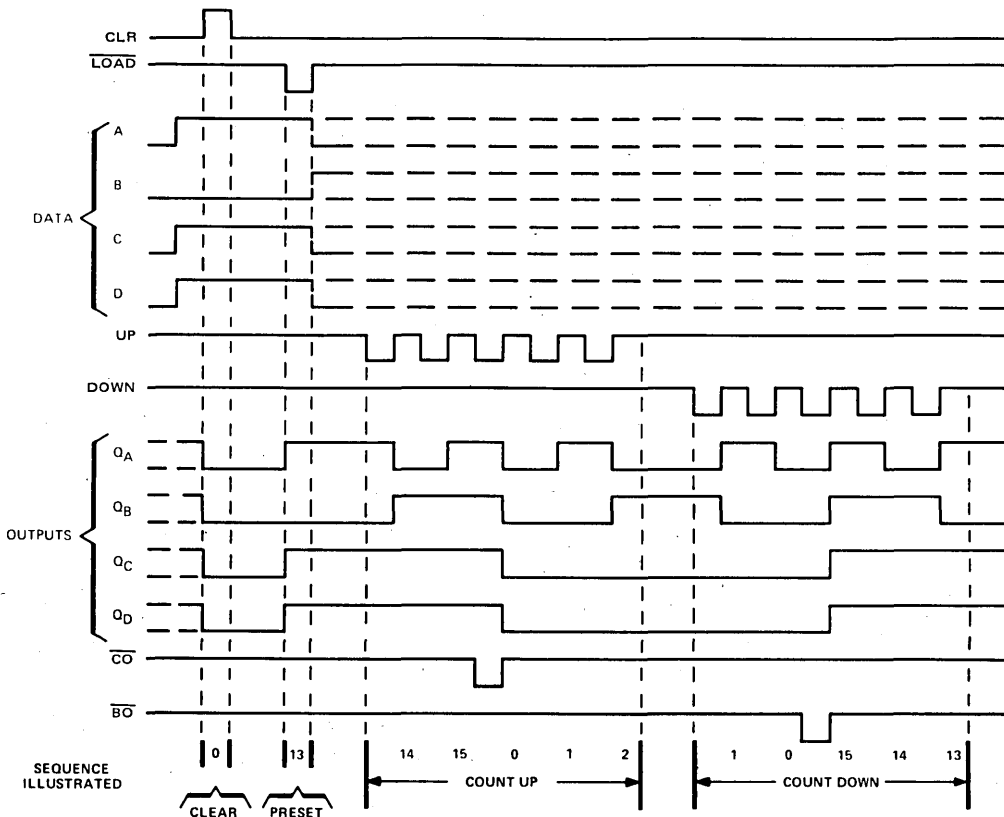

- NOTES:**
- A. Clear overrides load, data, and count inputs.
 - B. When counting up, count-down input must be high; when counting down, count-up input must be high.

TYPES SN54192, SN54193, SN74192, SN74193
SYNCHRONOUS 4-BIT UP/DOWN COUNTERS (DUAL CLOCK WITH CLEAR)

recommended operating conditions

	SN54192 SN54193			SN74192 SN74193			UNIT
	MIN	NOM	MAX	MIN	NOM	MAX	
V _{CC} Supply voltage	4.5	5	5.5	4.75	5	5.25	V
I _{OH} High-level output current			-0.4			-0.4	mA
I _{OL} Low-level output current			16			16	mA
f _{clock} Clock frequency	0		25	0		25	MHz
t _w Width of any input pulse		20			20		ns
t _{su} Data setup time, (see Figure 1)		20			20		ns
t _h Hold time		Data, high or low	0		0		ns
		LOAD	3		3		
T _A Operating free-air temperature		-55	125		0	70	°C

electrical characteristics over recommended operating free-air temperature range (unless otherwise noted)

PARAMETER	TEST CONDITIONS†	SN54192 SN54193			SN74192 SN74193			UNIT
		MIN	TYP‡	MAX	MIN	TYP‡	MAX	
V _{IH} High-level input voltage		2			2			V
V _{IL} Low-level input voltage				0.8			0.8	V
V _{IK} Input clamp voltage	V _{CC} = MIN, I _I = -12 mA			-1.5			-1.5	V
V _{OH} High-level output voltage	V _{CC} = MIN, V _{IH} = 2 V, V _{IL} = 0.8 V, I _{OH} = -0.4 mA	2.4	3.4		2.4	3.4		V
V _{OL} Low-level output voltage	V _{CC} = MIN, V _{IH} = 2 V, V _{IL} = 0.8 V, I _{OL} = 16 mA		0.2	0.4		0.2	0.4	V
I _I Input current at maximum input voltage	V _{CC} = MAX, V _I = 5.5 V			1			1	mA
I _{IH} High-level input current	V _{CC} = MAX, V _I = 2.4 V			40			40	µA
I _{IL} Low-level input current	V _{CC} = MAX, V _I = 0.4 V			-1.6			-1.6	mA
I _{OS} Short-circuit output current§	V _{CC} = MAX	-20		-65	-18		-65	mA
I _{CC} Supply current	V _{CC} = MAX, See Note 2		65	89		65	102	mA

† For conditions shown as MIN or MAX, use the appropriate value specified under recommended operating conditions for the applicable type.

‡ All typical values are at V_{CC} = 5 V, T_A = 25° C.

§ Not more than one output should be shorted at a time.

NOTE 2: I_{CC} is measured with all outputs open, clear and load inputs grounded, and all other inputs at 4.5 V.

switching characteristics, V_{CC} = 5 V, T_A = 25° C

PARAMETER¶	FROM INPUT	TO OUTPUT	TEST CONDITIONS	MIN	TYP	MAX	UNIT
f _{max}				25	32		MHz
t _{PLH}	UP	\overline{CO}	C _L = 15 pF, R _L = 400 Ω, See Figures 1 and 2		17	26	ns
t _{PHL}				16	24		
t _{PLH}	DOWN	\overline{BO}			16	24	ns
t _{PHL}				16	24		
t _{PLH}	UP OR DOWN	Q			25	38	ns
t _{PHL}				31	47		
t _{PLH}	\overline{LOAD}	Q			27	40	ns
t _{PHL}				29	40		
t _{PHL}	CLR	Q			22	35	ns

¶ f_{max} ≡ maximum clock frequency

t_{PLH} ≡ propagation delay time, low-to-high-level output

t_{PHL} ≡ propagation delay time, high-to-low-level output

3

TTL DEVICES



TYPES SN54L192, SN54L193 SYNCHRONOUS 4-BIT UP/DOWN COUNTERS (DUAL CLOCK WITH CLEAR)

recommended operating conditions

		SN54L192 SN54L193			UNIT	
		MIN	NOM	MAX		
V _{CC}	Supply voltage	4.5	5	5.5	V	
V _{IH}	High-level input voltage	2			V	
V _{IL}	Low-level input voltage				0.7	V
I _{OH}	High-level output current				-0.1	mA
I _{OL}	Low-level output current				2	mA
f _{clock}	Clock frequency	0	3		MHz	
t _w	Width of any input pulse	200			ns	
t _{su}	Data setup time, (see Figure 1)	100			ns	
t _h	Data hold time	0			ns	
T _A	Operating free-air temperature range	-55	125		°C	

electrical characteristics over recommended operating free-air temperature range (unless otherwise noted)

PARAMETER	TEST CONDITIONS†	SN54L192 SN54L193			UNIT
		MIN	TYP‡	MAX	
V _{IJK}	V _{CC} = MIN, I _I = -12 mA	-1.5			V
V _{OH}	V _{CC} = MIN, V _{IH} = 2 V, V _{IL} = 0.7 V, I _{OH} = -0.1 mA	2.4	3.3		V
V _{OL}	V _{CC} = MIN, V _{IH} = 2 V, V _{IL} = 0.7 V, I _{OL} = 2 mA	0.15		0.3	V
I _I	V _{CC} = MAX, V _I = 5.5 V	0.1			mA
I _{IH}	V _{CC} = MAX, V _I = 2.4 V	10			μA
I _{IL}	V _{CC} = MAX, V _I = 0.3 V	-0.18			mA
I _{OS§}	V _{CC} = MAX	-3	-15		mA
I _{CC}	V _{CC} = MAX, See Note 2	8.5		15	mA

† For conditions shown as MIN or MAX, use the appropriate value specified under recommended operating conditions for the applicable type.

‡ All typical values are at V_{CC} = 5 V, T_A = 25°C.

§ Not more than one output should be shorted at a time.

NOTE 2: I_{CC} is measured with all outputs open, clear and load inputs grounded, and all other inputs at 4.5 V.

switching characteristics, V_{CC} = 5 V, T_A = 25°C

PARAMETER¶	FROM INPUT	TO OUTPUT	TEST CONDITIONS	MIN	TYP	MAX	UNIT
f _{max}			C _L = 50 pF, R _L = 4 kΩ, See Figures 1 and 2	3	7		MHz
t _{PLH}	UP	$\overline{00}$		65	130		ns
t _{PHL}				65	130		
t _{PLH}	DOWN	$\overline{00}$		65	130		ns
t _{PHL}				65	130		
t _{PLH}	UP OR DOWN	Q		104	200		ns
t _{PHL}				135	240		
t _{PLH}	$\overline{\text{LOAD}}$	Q		130	240		ns
t _{PHL}				105	200		
t _{PHL}	CLR	Q			110	200	ns

¶ f_{max} ≡ maximum clock frequency

t_{PLH} ≡ propagation delay time, low-to-high-level output

t_{PHL} ≡ propagation delay time, high-to-low-level output

3

TTL DEVICES

TYPES SN54LS192, SN54LS193, SN74LS192, SN74LS193 SYNCHRONOUS 4-BIT UP/DOWN COUNTERS (DUAL CLOCK WITH CLEAR)

recommended operating conditions

		SN54LS192 SN54LS193			SN74LS192 SN74LS193			UNIT
		MIN	NOM	MAX	MIN	NOM	MAX	
V _{CC}	Supply voltage	4.5	5	5.5	4.75	5	5.25	V
I _{OH}	High-level output current	-400			-400			μA
I _{OL}	Low-level output current	4			8			mA
f _{clock}	Clock frequency	0	25		0	25		MHz
t _w	Width of any input pulse	20			20			ns
t _{su}	Clear inactive-state setup time	15			15			ns
	Load inactive-state setup time	15			15			ns
	Data setup time (see Figure 1)	20			20			ns
t _h	Data hold time	5			5			ns
T _A	Operating free-air temperature range	-55		125	0	70		°C

electrical characteristics over recommended operating free-air temperature range (unless otherwise noted)

PARAMETER	TEST CONDITIONS†	SN54LS192 SN54LS193			SN74LS192 SN74LS193			UNIT	
		MIN	TYP‡	MAX	MIN	TYP‡	MAX		
V _{IH}	High-level input voltage	2			2			V	
V _{IL}	Low-level input voltage	0.7			0.8			V	
V _{IK}	Input clamp voltage	V _{CC} = MIN, I _I = -18 mA			-1.5			V	
V _{OH}	High-level output voltage	V _{CC} = MIN, V _{IH} = 2 V, V _{IL} = V _{IL} max, I _{OH} = -400 μA			2.5	3.4	2.7	3.4	V
V _{OL}	Low-level output voltage	V _{CC} = MIN, V _{IH} = 2 V, V _{IL} = V _{IL} max			I _{OL} = 4 mA I _{OL} = 8 mA		0.15	0.4	V
I _I	Input current at maximum input voltage	V _{CC} = MAX, V _I = 7 V			0.1			mA	
I _{IH}	High-level input current	V _{CC} = MAX, V _I = 2.7 V			20			μA	
I _{IL}	Low-level input current	V _{CC} = MAX, V _I = 0.4 V			-0.4			mA	
I _{OS}	Short-circuit output current§	V _{CC} = MAX			-20	-100	-20	-100	mA
I _{CC}	Supply current	V _{CC} = MAX, See Note 2			19	.34	19	34	mA

† For conditions shown as MIN or MAX, use the appropriate value specified under recommended operating conditions for the applicable type.

‡ All typical values are at V_{CC} = 5 V, T_A = 25°C.

§ Not more than one output should be shorted at a time, and duration of the short-circuit should not exceed one second.

NOTE 2: I_{CC} is measured with all outputs open, clear and load inputs grounded, and all other inputs at 4.5 V.

switching characteristics, V_{CC} = 5 V, T_A = 25°C

PARAMETER	FROM INPUT	TO OUTPUT	TEST CONDITIONS	MIN	TYP	MAX	UNIT
f _{max}			C _L = 15 pF, R _L = 2 kΩ, See Figures 1 and 2	25	32		MHz
t _{PLH}	UP	\overline{CO}		17	26		ns
t _{PHL}				18	24		
t _{PLH}	DOWN	\overline{BO}		16	24		ns
t _{PHL}				15	24		
t _{PLH}	UP OR DOWN	Q		27	38		ns
t _{PHL}				30	47		
t _{PLH}	\overline{LOAD}	Q		24	40		ns
t _{PHL}				25	40		
t _{PHL}	CLR	Q		23	35		ns

PARAMETER MEASUREMENT INFORMATION

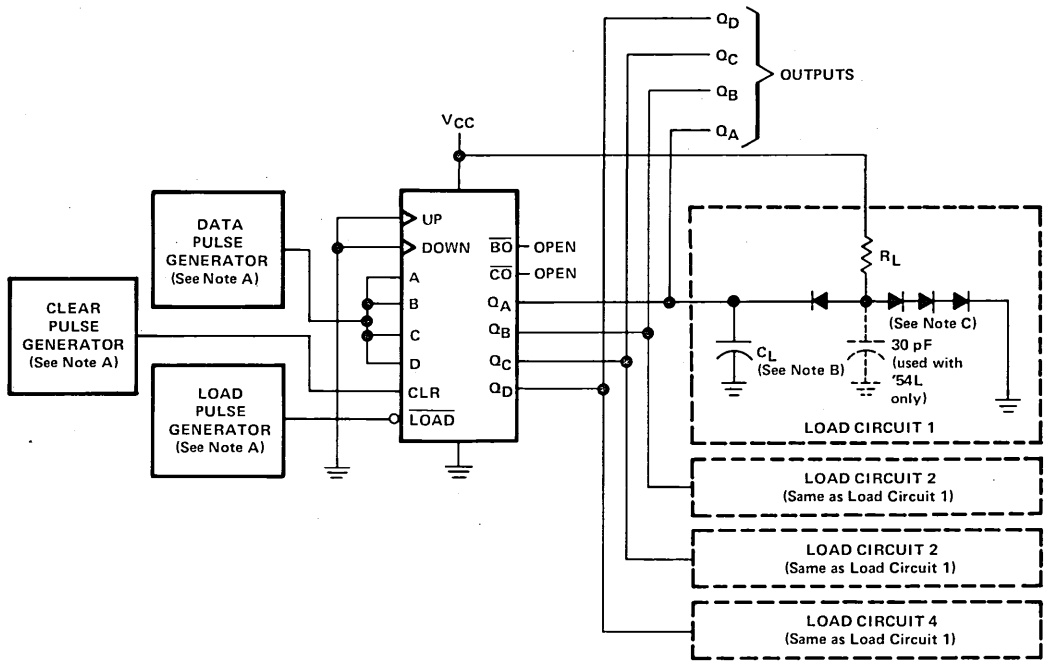

TEST CIRCUIT

- NOTES:
- A. The pulse generators have the following characteristics: $Z_{out} \approx 50 \Omega$ and for the data pulse generator $PRR \leq 500 \text{ kHz}$, duty cycle = 50%; for the load pulse generator PRR is two times data PRR , duty cycle = 50%.
 - B. C_L includes probe and jig capacitance.
 - C. Diodes are 1N3064 or equivalent.
 - D. t_r and $t_f \leq 7 \text{ ns}$ for '192, '193, 'LS192, and 'LS193; $\leq 25 \text{ ns}$ for 'L192 and 'L193.
 - E. V_{ref} is 1.5 volts for '192 and '193; 1.3 volts for 'L192, 'L193; 'LS192, and 'LS193.

FIGURE 1A - CLEAR, SETUP AND LOAD TIMES

TYPES SN54192, SN54193, SN54L192, SN54L193, SN54LS192, SN54LS193,
 SN74192, SN74193, SN74LS192, SN74LS193
 SYNCHRONOUS 4-BIT UP/DOWN COUNTERS (DUAL CLOCK WITH CLEAR)

PARAMETER MEASUREMENT INFORMATION

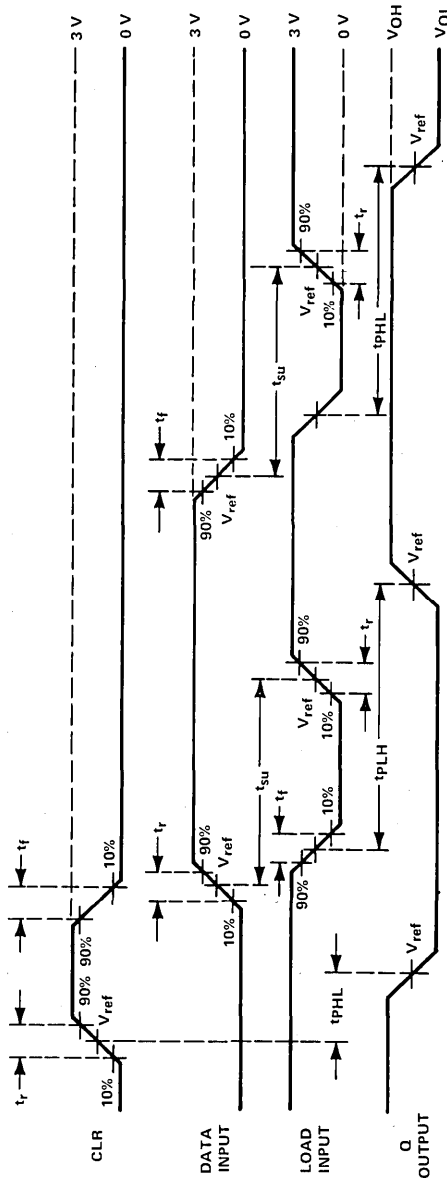

VOLTAGE WAVEFORMS

- NOTES: A. The pulse generators have the following characteristics: $Z_{out} \approx 50 \Omega$ and for the data pulse generator PRR ≤ 500 kHz, duty cycle = 50%; for the load pulse generator PRR is two times data PRR, duty cycle = 50%.
 B. C_L includes probe and jig capacitance.
 C. Diodes are 1N3064 or equivalent.
 D. t_r and $t_f \leq 7$ ns for '192, '193, 'LS192, and 'LS193; ≤ 25 ns for 'L192 and 'L193.
 E. V_{ref} is 1.5 volts for '192 and '193; 1.3 volts for 'L192, 'L193, 'LS192, and 'LS193.

FIGURE 1B - CLEAR, SETUP, AND LOAD TIMES

TYPES SN54192, SN54193, SN54L192, SN54L193, SN54LS192, SN54LS193,
 SN74192, SN74193, SN74LS192, SN74LS193
 SYNCHRONOUS 4-BIT UP/DOWN COUNTERS (DUAL CLOCK WITH CLEAR)

PARAMETER MEASUREMENT INFORMATION

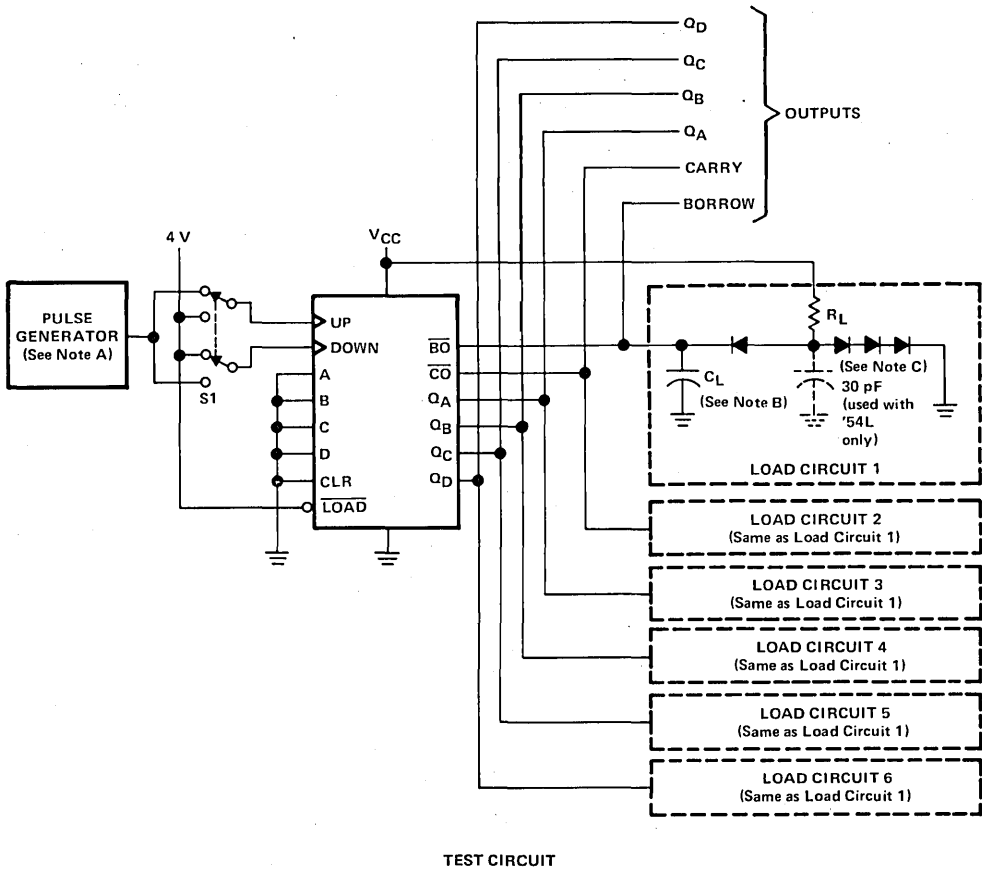

TEST CIRCUIT

- NOTES: A. The pulse generator has the following characteristics: $PRR \leq 1 \text{ MHz}$, $Z_{out} \approx 50 \Omega$, duty cycle = 50%.
 B. C_L includes probe and jig capacitance.
 C. Diodes are 1N3064 or equivalent.
 D. Count-up and count-down pulse shown are for the '193, 'L193, and 'LS193 binary counters. Count cycle for '192, 'L192, and 'LS192 decade counters is 1 through 10.
 E. Waveforms for outputs Q_A , Q_B , and Q_C are omitted to simplify the drawing.
 F. t_r and $t_f \leq 7 \text{ ns}$ for '192, '193, 'LS192, and 'LS193; $\leq 25 \text{ ns}$ for 'L192 and 'L193.
 G. V_{ref} is 1.5 volts for '192 and '193; 1.3 volts for 'L192, 'L193, 'LS192, and 'LS193.

FIGURE 2A – PROPAGATION DELAY TIMES

TYPES SN54192, SN54193, SN54L192, SN54L193, SN54LS192, SN54LS193,
SN74192, SN74193, SN74LS192, SN74LS193
SYNCHRONOUS 4-BIT UP/DOWN COUNTERS (DUAL CLOCK WITH CLEAR)

PARAMETER MEASUREMENT INFORMATION

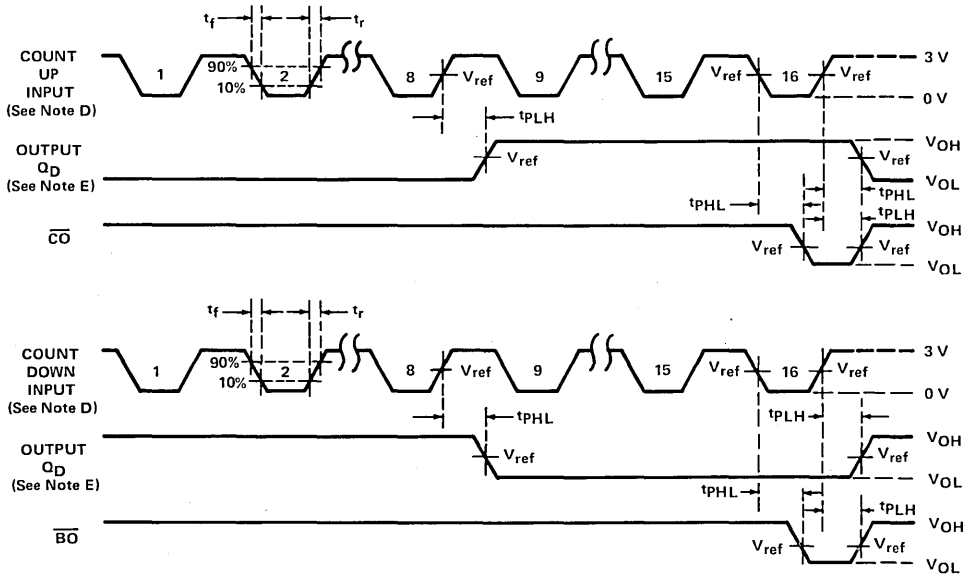

VOLTAGE WAVEFORMS

- NOTES:
- A. The pulse generator has the following characteristics: $PRR \leq 1 \text{ MHz}$, $Z_{out} \approx 50 \Omega$, duty cycle = 50%.
 - B. C_L includes probe and jig capacitance.
 - C. Diodes are 1N3064 or equivalent.
 - D. Count-up and count-down pulse shown are for the '193, 'L193, and 'LS193 binary counters. Count cycle for '192, 'L192, and 'LS192 decade counters is 1 through 10.
 - E. Waveforms for outputs Q_A , Q_B , and Q_C are omitted to simplify the drawing.
 - F. t_r and $t_f \leq 7 \text{ ns}$ for '192, '193, 'LS192, and 'LS193; $\leq 25 \text{ ns}$ for 'L192 and 'L193.
 - G. V_{ref} is 1.5 volts for '192 and '193; 1.3 volts for 'L192, 'L193, 'LS192, and 'LS193.

FIGURE 2B - PROPAGATION DELAY TIMES



TTL DEVICES

TYPES SN54194, SN54LS194A, SN54S194, SN74194, SN74LS194A, SN74S194 4-BIT BIDIRECTIONAL UNIVERSAL SHIFT REGISTERS

MARCH 1974—REVISED APRIL 1985

- Parallel Inputs and Outputs
- Four Operating Modes:
Synchronous Parallel Load
Right Shift
Left Shift
Do Nothing
- Positive Edge-Triggered Clocking
- Direct Overriding Clear

TYPE	TYPICAL MAXIMUM CLOCK FREQUENCY	TYPICAL POWER DISSIPATION
'194	36 MHz	195 mW
'LS194A	36 MHz	75 mW
'S194	105 MHz	425 mW

description

These bidirectional shift registers are designed to incorporate virtually all of the features a system designer may want in a shift register. The circuit contains 46 equivalent gates and features parallel inputs, parallel outputs, right-shift and left-shift serial inputs, operating-mode-control inputs, and a direct overriding clear line. The register has four distinct modes of operation, namely:

- Inhibit clock (do nothing)
- Shift right (in the direction Q_A toward Q_D)
- Shift left (in the direction Q_D toward Q_A)
- Parallel (broadside) load

Synchronous parallel loading is accomplished by applying the four bits of data and taking both mode control inputs, S0 and S1, high. The data are loaded into the associated flip-flops and appear at the outputs after the positive transition of the clock input. During loading, serial data flow is inhibited.

Shift right is accomplished synchronously with the rising edge of the clock pulse when S0 is high and S1 is low. Serial data for this mode is entered at the shift-right data input. When S0 is low and S1 is high, data shifts left synchronously and new data is entered at the shift-left serial input.

Clocking of the shift register is inhibited when both mode control inputs are low. The mode controls of the SN54194/SN74194 should be changed only while the clock input is high.

SN54194, SN54LS194A, SN54S194 ... J OR W PACKAGE
SN74194 ... J OR N PACKAGE
SN74LS194A, SN74S194 ... D, J OR N PACKAGE
(TOP VIEW)

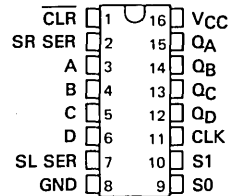

SN54LS194A, SN54S194 ... FK PACKAGE
SN74LS194A, SN74S194 ... FN PACKAGE
(TOP VIEW)

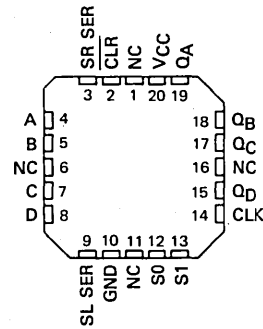

NC - No internal connection

PRODUCTION DATA
This document contains information current as of publication date. Products conform to specifications per the terms of Texas Instruments standard warranty. Production processing does not necessarily include testing of all parameters.

**TEXAS
INSTRUMENTS**

POST OFFICE BOX 225012 • DALLAS, TEXAS 75285

TTL DEVICES

3

TYPES SN54194, SN54LS194A, SN54S194, SN74194, SN74LS194A, SN74S194 4-BIT BIDIRECTIONAL UNIVERSAL SHIFT REGISTERS

FUNCTION TABLE

CLEAR	MODE		CLOCK	INPUTS				OUTPUTS					
	S1	S0		SERIAL		PARALLEL		QA	QB	QC	QD		
				LEFT	RIGHT	A	B					C	D
L	X	X	X	X	X	X	X	X	X	L	L	L	L
H	X	X	L	X	X	X	X	X	X	QA0	QB0	QC0	QD0
H	H	H	↑	X	X	a	b	c	d	a	b	c	d
H	L	H	↑	X	H	X	X	X	X	H	QA _n	QB _n	QC _n
H	L	H	↑	X	L	X	X	X	X	L	QA _n	QB _n	QC _n
H	H	L	↑	H	X	X	X	X	X	QB _n	QC _n	QD _n	H
H	H	L	↑	L	X	X	X	X	X	QB _n	QC _n	QD _n	L
H	L	L	X	X	X	X	X	X	X	QA0	QB0	QC0	QD0

H = high level (steady state)
L = low level (steady state)
X = irrelevant (any input, including transitions)
↑ = transition from low to high level
a, b, c, d = the level of steady-state input at inputs A, B, C, or D, respectively.
QA0, QB0, QC0, QD0 = the level of QA, QB, QC, or QD, respectively, before the indicated steady-state input conditions were established.
QA_n, QB_n, QC_n, QD_n = the level of QA, QB, QC, respectively, before the most-recent ↑ transition of the clock.

schematics of inputs and outputs

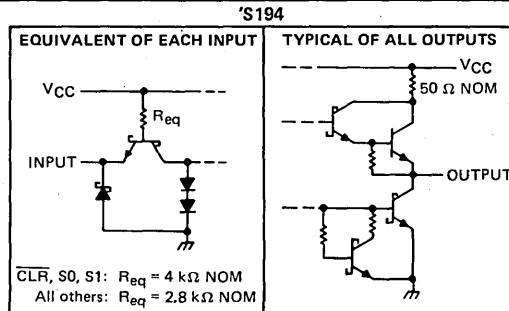
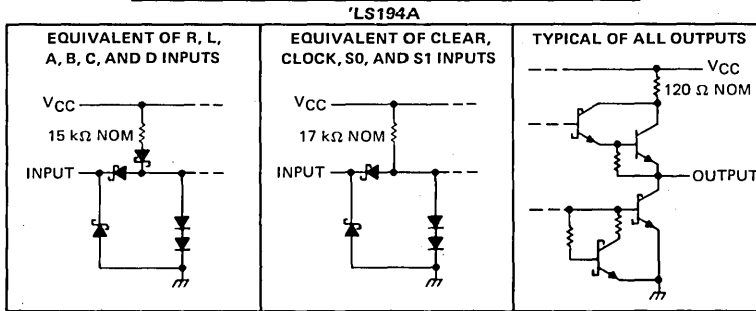
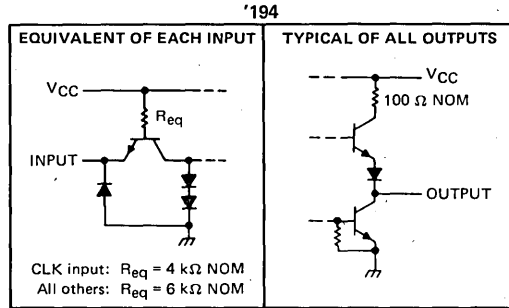

3

TTL DEVICES

TYPES SN54194, SN74194
4-BIT BIDIRECTIONAL UNIVERSAL SHIFT REGISTERS

logic diagrams

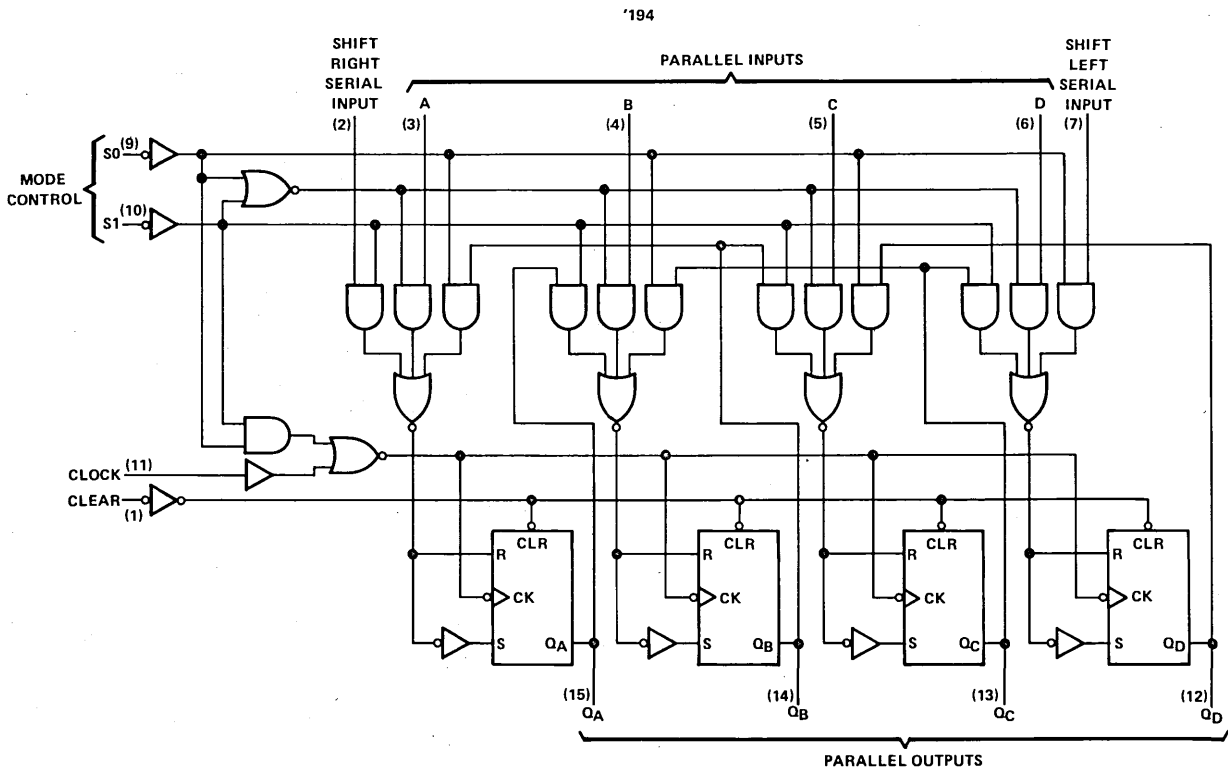

Pin numbers shown on logic notation are for D, J or N packages.



TYPES SN54LS194A, SN54S194,
 SN74LS194A, SN74S194
 4-BIT BIDIRECTIONAL UNIVERSAL SHIFT REGISTERS

logic diagrams (continued)

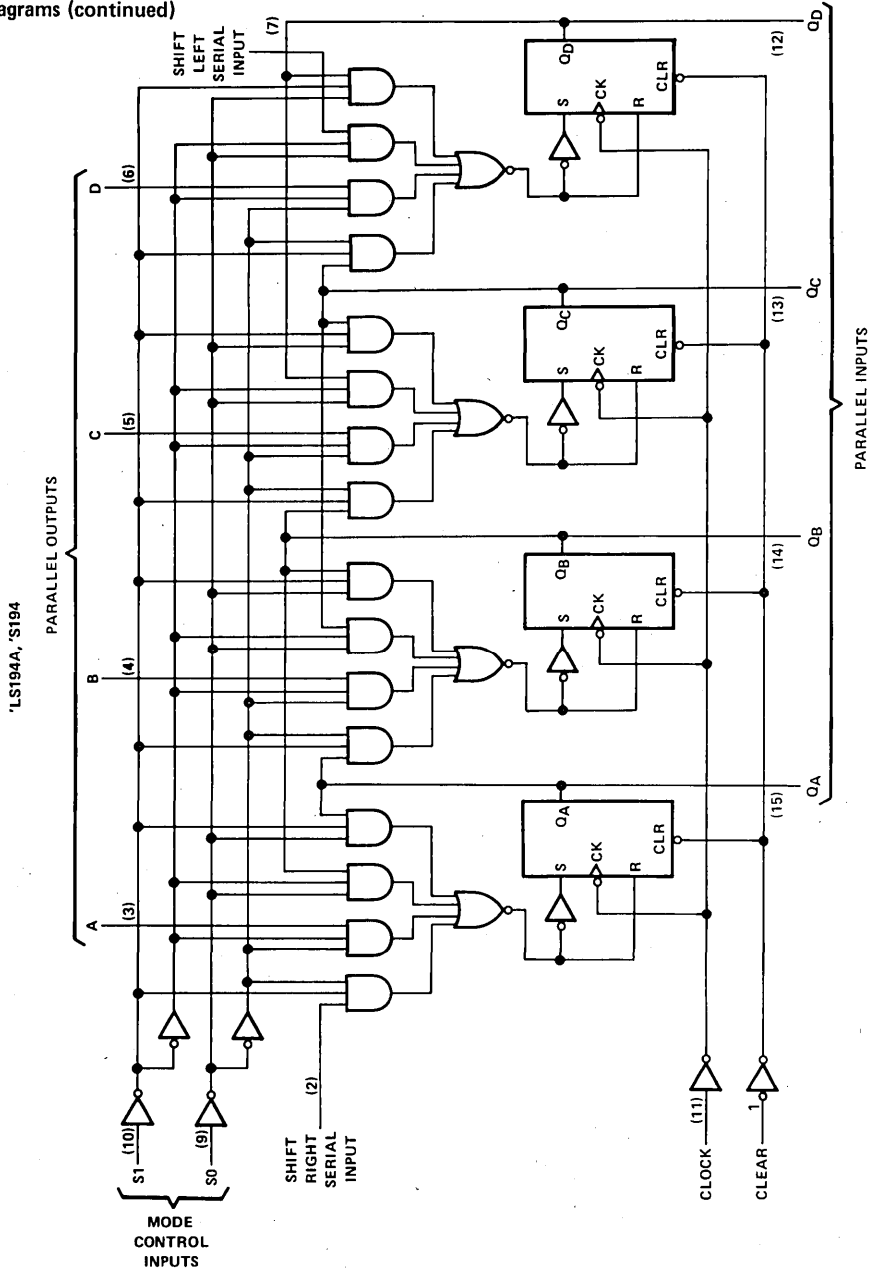

Pin numbers shown on logic notation are for D, J or N packages.

TYPES SN54194, SN54LS194A, SN54S194,
SN74194, SN74LS194A, SN74S194
4-BIT BIDIRECTIONAL UNIVERSAL SHIFT REGISTERS

typical clear, load, right-shift, left-shift, inhibit, and clear sequences

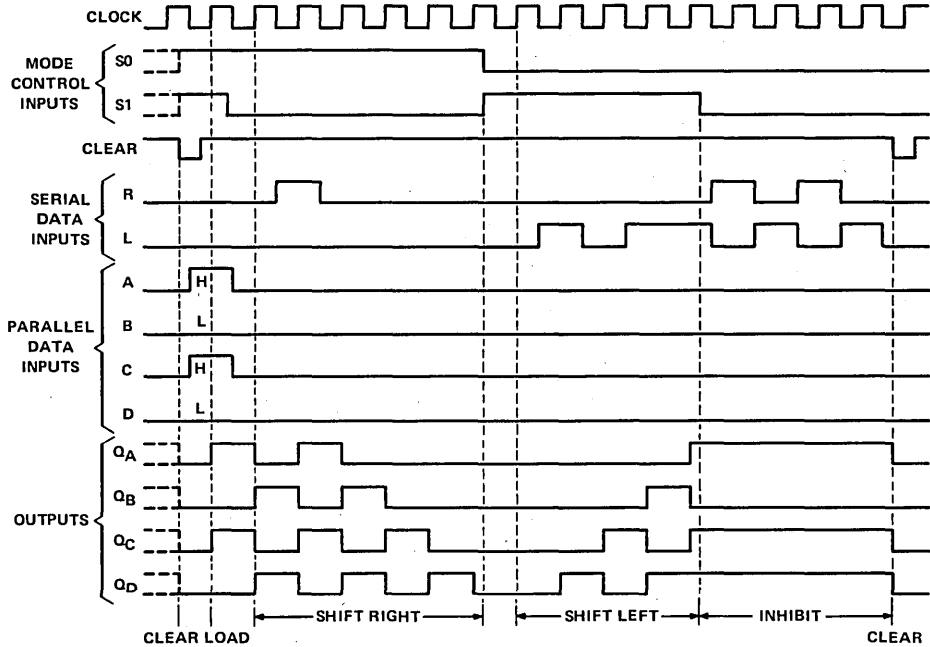

TYPES SN54194, SN74194

4-BIT BIDIRECTIONAL UNIVERSAL SHIFT REGISTERS

absolute maximum ratings over operating free-air temperature range (unless otherwise noted)

Supply voltage, V_{CC} (see Note 1)	7 V
Input voltage	5.5 V
Operating free-air temperature range: SN54194	-55°C to 125°C
SN74194	0°C to 70°C
Storage temperature range	-65°C to 150°C

NOTE 1: Voltage values are with respect to network ground terminal.

recommended operating conditions

	SN54194			SN74194			UNIT
	MIN	NOM	MAX	MIN	NOM	MAX	
Supply voltage, V_{CC}	4.5	5	5.5	4.75	5	5.25	V
High-level output current, I_{OH}			-800			-800	μ A
Low-level output current, I_{OL}			16			16	mA
Clock frequency, f_{clock}	0		25	0		25	MHz
Width of clock or clear pulse, t_w		20			20		ns
Setup time, t_{SU}	Mode control		30	30			ns
	Serial and parallel data		20	20			ns
	Clear inactive-state		25	25			ns
Hold time at any input, t_H		0			0		ns
Operating free-air temperature, T_A		-55	125		0	70	°C

electrical characteristics over recommended operating free-air temperature range (unless otherwise noted)

PARAMETER	TEST CONDITIONS†	SN54194			SN74194			UNIT
		MIN	TYP‡	MAX	MIN	TYP‡	MAX	
V_{IH} High-level input voltage		2			2			V
V_{IL} Low-level input voltage				0.8			0.8	V
V_{IK} Input clamp voltage	$V_{CC} = \text{MIN}, I_I = -12 \text{ mA}$			-1.5			-1.5	V
V_{OH} High-level output voltage	$V_{CC} = \text{MIN}, V_{IH} = 2 \text{ V}, V_{IL} = 0.8 \text{ V}, I_{OH} = -800 \mu\text{A}$	2.4	3.4		2.4	3.4		V
V_{OL} Low-level output voltage	$V_{CC} = \text{MIN}, V_{IH} = 2 \text{ V}, V_{IL} = 0.8 \text{ V}, I_{OL} = 16 \text{ mA}$		0.2	0.4		0.2	0.4	V
I_I Input current at maximum input voltage	$V_{CC} = \text{MAX}, V_I = 5.5 \text{ V}$			1			1	mA
I_{IH} High-level input current	$V_{CC} = \text{MAX}, V_I = 2.4 \text{ V}$			40			40	μ A
I_{IL} Low-level input current	$V_{CC} = \text{MAX}, V_I = 0.4 \text{ V}$			-1.6			-1.6	mA
I_{OS} Short-circuit output current§	$V_{CC} = \text{MAX}$	-20		-57	-18		-57	mA
I_{CC} Supply current	$V_{CC} = \text{MAX}$, See Note 2		39	63		39	63	mA

† For conditions shown as MIN or MAX, use the appropriate value specified under recommended operating conditions.

‡ All typical values are at $V_{CC} = 5 \text{ V}, T_A = 25^\circ \text{C}$.

§ Not more than one output should be shorted at a time.

NOTE 2: With all outputs open, inputs A through D grounded, and 4.5 V applied to S0, S1, clear, and the serial inputs, I_{CC} is tested with a momentary GND, then 4.5 V applied to clock.

switching characteristics, $V_{CC} = 5 \text{ V}, T_A = 25^\circ \text{C}$

PARAMETER	TEST CONDITIONS	MIN	TYP	MAX	UNIT
f_{max} Maximum clock frequency	$C_L = 15 \text{ pF}, R_L = 400 \Omega,$ See Figure 1	25	36		MHz
t_{PHL} Propagation delay time, high-to-low-level output from clear			19	30	ns
t_{PLH} Propagation delay time, low-to-high-level output from clear			14	22	ns
t_{PHL} Propagation delay time, high-to-low-level output from clock			17	26	ns

3

TTL DEVICES

TYPES SN54LS194A, SN74LS194A 4-BIT BIDIRECTIONAL UNIVERSAL SHIFT REGISTERS

absolute maximum ratings over operating free-air temperature range (unless otherwise noted)

Supply voltage, V_{CC} (see Note 1)	7 V
Input voltage	7 V
Operating free-air temperature range: SN54LS194A	-55°C to 125°C
SN74LS194A	0°C to 70°C
Storage temperature range	-65°C to 150°C

NOTE 1: Voltage values are with respect to network ground terminal.

recommended operating conditions

	SN54LS194A			SN74LS194A			UNIT
	MIN	NOM	MAX	MIN	NOM	MAX	
Supply voltage, V_{CC}	4.5	5	5.5	4.75	5	5.25	V
High-level output current, I_{OH}	-400			-400			μ A
Low-level output current, I_{OL}	4			8			mA
Clock frequency, f_{clock}	0	25		0	25		MHz
Width of clock or clear pulse, t_w	20			20			ns
Setup time, t_{su}	Mode control			30			ns
	Serial and parallel data			20			ns
	Clear inactive-state			25			ns
Hold time at any input, t_h	0			0			ns
Operating free-air temperature, T_A	-55	125		0	70		°C

electrical characteristics over recommended operating free-air temperature range (unless otherwise noted)

PARAMETER	TEST CONDITIONS†	SN54LS194A			SN74LS194A			UNIT
		MIN	TYP‡	MAX	MIN	TYP‡	MAX	
V_{IH} High-level input voltage		2			2			V
V_{IL} Low-level input voltage		0.7			0.8			V
V_I Input clamp voltage	$V_{CC} = \text{MIN}, I_I = -18 \text{ mA}$	-1.5			-1.5			V
V_{OH} High-level output voltage	$V_{CC} = \text{MIN}, V_{IH} = 2 \text{ V}, V_{IL} = V_{IL \text{ max}}, I_{OH} = -400 \mu\text{A}$	2.5	3.5		2.7	3.5		V
V_{OL} Low-level output voltage	$V_{CC} = \text{MIN}, V_{IH} = 2 \text{ V}, V_{IL} = V_{IL \text{ max}}, I_{OL} = 4 \text{ mA}$ $I_{OL} = 8 \text{ mA}$	0.25		0.4	0.25		0.4	V
I_I Input current at maximum input voltage	$V_{CC} = \text{MAX}, V_I = 7 \text{ V}$	0.1			0.1			mA
I_{IH} High-level input current	$V_{CC} = \text{MAX}, V_I = 2.7 \text{ V}$	20			20			μ A
I_{IL} Low-level input current	$V_{CC} = \text{MAX}, V_I = 0.4 \text{ V}$	-0.4			-0.4			mA
I_{OS} Short-circuit output current§	$V_{CC} = \text{MAX}$	-20	-100		-20	-100		mA
I_{CC} Supply current	$V_{CC} = \text{MAX},$ See Note 2	15		23	15		23	mA

† For conditions shown as MIN or MAX, use the appropriate value specified under recommended operating conditions.

‡ All typical values are at $V_{CC} = 5 \text{ V}, T_A = 25^\circ\text{C}$.

§ Not more than one output should be shorted at a time, and duration of the short-circuit should not exceed one second.

NOTE 2: With all outputs open, inputs A through D grounded, and 4.5 V applied to S0, S1, clear, and the serial inputs, I_{CC} is tested with a momentary GND, then 4.5 V, applied to clock.

switching characteristics, $V_{CC} = 5 \text{ V}, T_A = 25^\circ\text{C}$

PARAMETER	TEST CONDITIONS	MIN	TYP	MAX	UNIT
f_{max} Maximum clock frequency	$C_L = 15 \text{ pF},$ $R_L = 2 \text{ k}\Omega,$ See Figure 1	25	36		MHz
t_{PHL} Propagation delay time, high-to-low-level output from clear			19	30	ns
t_{PLH} Propagation delay time, low-to-high-level output from clock			14	22	ns
t_{PHL} Propagation delay time, high-to-low-level output from clock			17	26	ns

3
TTL DEVICES

TYPES SN54S194, SN74S194

4-BIT BIDIRECTIONAL UNIVERSAL SHIFT REGISTERS

absolute maximum ratings over operating free-air temperature range (unless otherwise noted)

Supply voltage, V_{CC} (see Note 1)	7 V
Input voltage	5.5 V
Operating free-air temperature range: SN54S194	-55°C to 125°C
SN74S194	0°C to 70°C
Storage temperature range	-65°C to 150°C

NOTE 1: Voltage values are with respect to network ground terminal.

recommended operating conditions

	SN54S194			SN74S194			UNIT
	MIN	NOM	MAX	MIN	NOM	MAX	
Supply voltage, V_{CC}	4.5	5	5.5	4.75	5	5.25	V
High-level output current, I_{OH}			-1			-1	mA
Low-level output current, I_{OL}			20			20	mA
Clock frequency, f_{clock}	0		70	0		70	MHz
Width of clock pulse, $t_{w(clock)}$	7			7			ns
Width of clear pulse, $t_{w(clear)}$	12			12			ns
Setup time, t_{SU}	Mode control		11			11	ns
	Serial and parallel data		5			5	ns
	Clear inactive-state		9			9	ns
Hold time at any input, t_H			3			3	ns
Operating free-air temperature, T_A	-55		125	0		70	°C

electrical characteristics over recommended operating free-air temperature range (unless otherwise noted)

PARAMETER	TEST CONDITIONS†	SN54S194			SN74S194			UNIT
		MIN	TYP‡	MAX	MIN	TYP‡	MAX	
V_{IH} High-level input voltage		2			2			V
V_{IL} Low-level input voltage				0.8			0.8	V
V_{IK} Input clamp voltage	$V_{CC} = \text{MIN}, I_I = -18 \text{ mA}$			-1.2			-1.2	V
V_{OH} High-level output voltage	$V_{CC} = \text{MIN}, V_{IH} = 2 \text{ V}, V_{IL} = 0.8 \text{ V}, I_{OH} = -1 \text{ mA}$	2.5	3.4		2.7	3.4		V
V_{OL} Low-level output voltage	$V_{CC} = \text{MIN}, V_{IH} = 2 \text{ V}, V_{IL} = 0.8 \text{ V}, I_{OL} = 20 \text{ mA}$			0.5			0.5	V
I_I Input current at maximum input voltage	$V_{CC} = \text{MAX}, V_I = 5.5 \text{ V}$			1			1	mA
I_{IH} High-level input current	$V_{CC} = \text{MAX}, V_I = 2.7 \text{ V}$			50			50	µA
I_{IL} Low-level input current	$V_{CC} = \text{MAX}, V_I = 0.5 \text{ V}$			-2			-2	µA
I_{OS} Short-circuit output current §	$V_{CC} = \text{MAX}$	-40		-100	-40		-100	mA
I_{CC} Supply current	$V_{CC} = \text{MAX}$, See Note 2		85	135		85	135	mA
	$V_{CC} = \text{MAX}, T_A = 125^\circ\text{C}$, See Note 2	W package		110				

† For conditions shown as MIN or MAX, use the appropriate value specified under recommended operating conditions.

‡ All typical values are at $V_{CC} = 5 \text{ V}, T_A = 25^\circ\text{C}$.

§ Not more than one output should be shorted at a time, and duration of the short-circuit should not exceed one second.

NOTE 2: With all outputs open, inputs A through D grounded, and 4.5 V applies to S0, S1, clear, and the serial inputs, I_{CC} is tested with a momentary GND, then 4.5 V, applied to clock.

switching characteristics, $V_{CC} = 5 \text{ V}, T_A = 25^\circ\text{C}$

PARAMETER	TEST CONDITIONS	MIN	TYP	MAX	UNIT	
f_{max} Maximum clock frequency	$C_L = 15 \text{ pF}, R_L = 280 \Omega$, See Figure 1	70	105		MHz	
t_{PHL} Propagation delay time, high-to-low-level output from clear			12.5	18.5	ns	
t_{PLH} Propagation delay time, low-to-high-level output from clock			4	8	12	ns
t_{PHL} Propagation delay time, high-to-low-level output from clock			4	11	16.5	ns

**TYPES SN54194, SN54LS194A, SN54S194,
SN74194, SN74LS194A, SN74S194
4-BIT BIDIRECTIONAL UNIVERSAL SHIFT REGISTERS**

PARAMETER MEASUREMENT INFORMATION

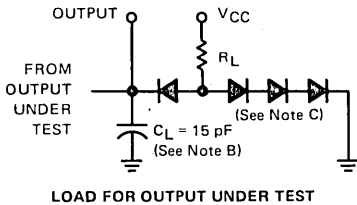

TEST TABLE FOR SYNCHRONOUS INPUTS

DATA INPUT FOR TEST	S1	S0	OUTPUT TESTED (SEE NOTE E)
A	4.5 V	4.5 V	QA at t_{n+1}
B	4.5 V	4.5 V	QB at t_{n+1}
C	4.5 V	4.5 V	QC at t_{n+1}
D	4.5 V	4.5 V	QD at t_{n+1}
L Serial Input	4.5 V	0 V	QA at t_{n+4}
R Serial Input	0 V	4.5 V	QD at t_{n+4}

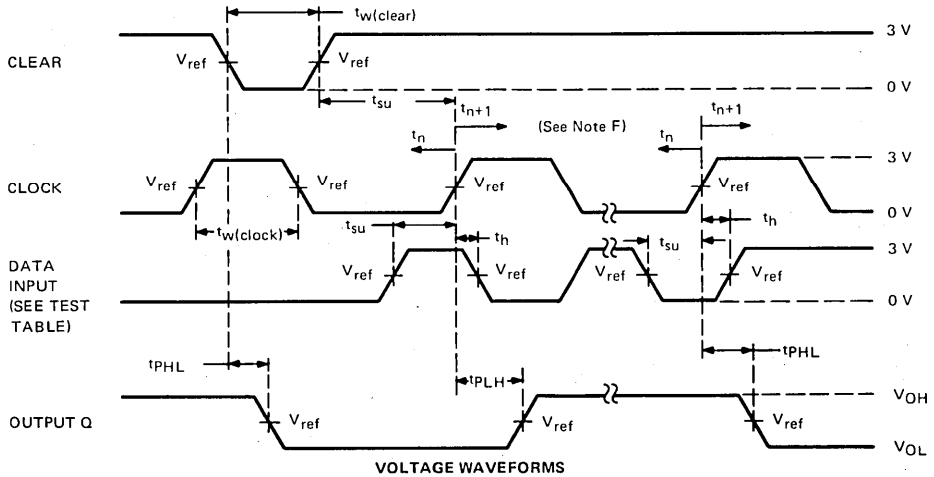

- NOTES:**
- A. The clock pulse generator has the following characteristics: $Z_{out} \approx 50 \Omega$ and $PRR \leq 1 \text{ MHz}$, For '194, $t_r \leq 7 \text{ ns}$ and $t_f \leq 7 \text{ ns}$. For 'LS194A, $t_r \leq 15 \text{ ns}$ and $t_f \leq 6 \text{ ns}$. For 'S194, $t_r \leq 2.5 \text{ ns}$ and $t_f \leq 2.5 \text{ ns}$. When testing f_{max} , vary PRR.
 - B. C_L includes probe and jig capacitance.
 - C. All diodes are 1N3064 or 1N916.
 - D. A clear pulse is applied prior to each test.
 - E. For '194 and 'S194, $V_{ref} = 1.5 \text{ V}$; for 'LS194A, $V_{ref} = 1.3 \text{ V}$.
 - F. Propagation delay times (t_{PLH} and t_{PHL}) are measured at t_{n+1} . Proper shifting of data is verified at t_{n+4} with a functional test.
 - G. t_n = bit time before clocking transition.
 t_{n+1} = bit time after one clocking transition.
 t_{n+4} = bit time after four clocking transitions.

FIGURE 1—SWITCHING TIMES

TYPES SN54195, SN54LS195A, SN54S195, SN74195, SN74LS195A, SN74S195 4-BIT PARALLEL-ACCESS SHIFT REGISTERS

MARCH 1974—REVISED APRIL 1985

- Synchronous Parallel Load
- Positive-Edge-Triggered Clocking
- Parallel Inputs and Outputs from Each Flip-Flop
- Direct Overriding Clear
- J and \bar{K} Inputs to First Stage
- Complementary Outputs from Last Stage
- For Use in High Performance: Accumulators/Processors Serial-to-Parallel, Parallel-to-Serial Converters

SN54195, SN54LS195A, SN54S195 . . . J OR W PACKAGE
SN74195 . . . J OR N PACKAGE
SN74LS195A, SN74S195 . . . D, J OR N PACKAGE
(TOP VIEW)

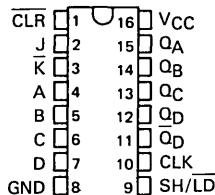

SN54LS195, SN54S195 . . . FK PACKAGE
SN74LS195, SN74S195 . . . FN PACKAGE
(TOP VIEW)

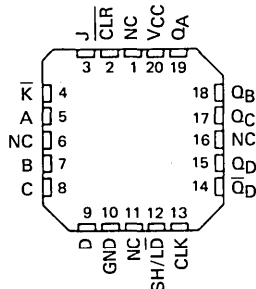

NC - No internal connection

description

These 4-bit registers feature parallel inputs, parallel outputs, J-K serial inputs, shift/load control input, and a direct overriding clear. All inputs are buffered to lower the input drive requirements. The registers have two modes of operation:

Parallel (broadside) load
Shift (in the direction Q_A toward Q_D)

Parallel loading is accomplished by applying the four bits of data and taking the shift/load control input low. The data is loaded into the associated flip-flop and appears at the outputs after the positive transition of the clock input. During loading, serial data flow is inhibited.

Shifting is accomplished synchronously when the shift/load control input is high. Serial data for this mode is entered at the J-K inputs. These inputs permit the first stage to perform as a J-K, D-, or T-type flip-flop as shown in the function table.

The high-performance 'S195, with a 105-megahertz typical maximum shift-frequency, is particularly attractive for very-high-speed data processing systems. In most cases existing systems can be upgraded merely by using this Schottky-clamped shift register.

TYPE	TYPICAL MAXIMUM CLOCK FREQUENCY	TYPICAL POWER DISSIPATION
'195	39 MHz	195 mW
'LS195A	39 MHz	70 mW
'S195	105 MHz	350 mW

FUNCTION TABLE

INPUTS			OUTPUTS									
CLEAR	SHIFT/ LOAD	CLOCK	SERIAL		PARALLEL			Q_A	Q_B	Q_C	Q_D	\bar{Q}_D
			J	\bar{K}	A	B	C					
L	X	X	X	X	X	X	X	L	L	L	L	H
H	L	↑	X	X	a	b	c	d	a	b	c	d
H	H	L	X	X	X	X	X	Q_{A0}	Q_{B0}	Q_{C0}	Q_{D0}	\bar{Q}_{D0}
H	H	↑	L	H	X	X	X	Q_{A0}	Q_{Bn}	Q_{Cn}	\bar{Q}_{Cn}	
H	H	↑	L	L	X	X	X	L	Q_{An}	Q_{Bn}	Q_{Cn}	\bar{Q}_{Cn}
H	H	↑	H	H	X	X	X	H	Q_{An}	Q_{Bn}	Q_{Cn}	\bar{Q}_{Cn}
H	H	↑	H	L	X	X	X	\bar{Q}_{An}	Q_{An}	Q_{Bn}	Q_{Cn}	\bar{Q}_{Cn}

H = high level (steady state)
L = low level (steady state)
X = irrelevant (any input, including transitions)
↑ = transition from low to high level
a, b, c, d = the level of steady-state input at A, B, C, or D, respectively
 $Q_{A0}, Q_{B0}, Q_{C0}, Q_{D0}$ = the level of $Q_A, Q_B, Q_C,$ or Q_D , respectively, before the indicated steady-state input conditions were established
 Q_{An}, Q_{Bn}, Q_{Cn} = the level of $Q_A, Q_B,$ or Q_C , respectively, before the most-recent transition of the clock

PRODUCTION DATA
This document contains information current as of publication date. Products conform to specifications per the terms of Texas Instruments standard warranty. Production processing does not necessarily include testing of all parameters.



POST OFFICE BOX 225012 • DALLAS, TEXAS 75265

3

TTL DEVICES

TYPES SN54195, SN54LS195A, SN54S195,
 SN74195, SN74LS195A, SN74S195
 4-BIT PARALLEL-ACCESS SHIFT REGISTERS

logic diagram

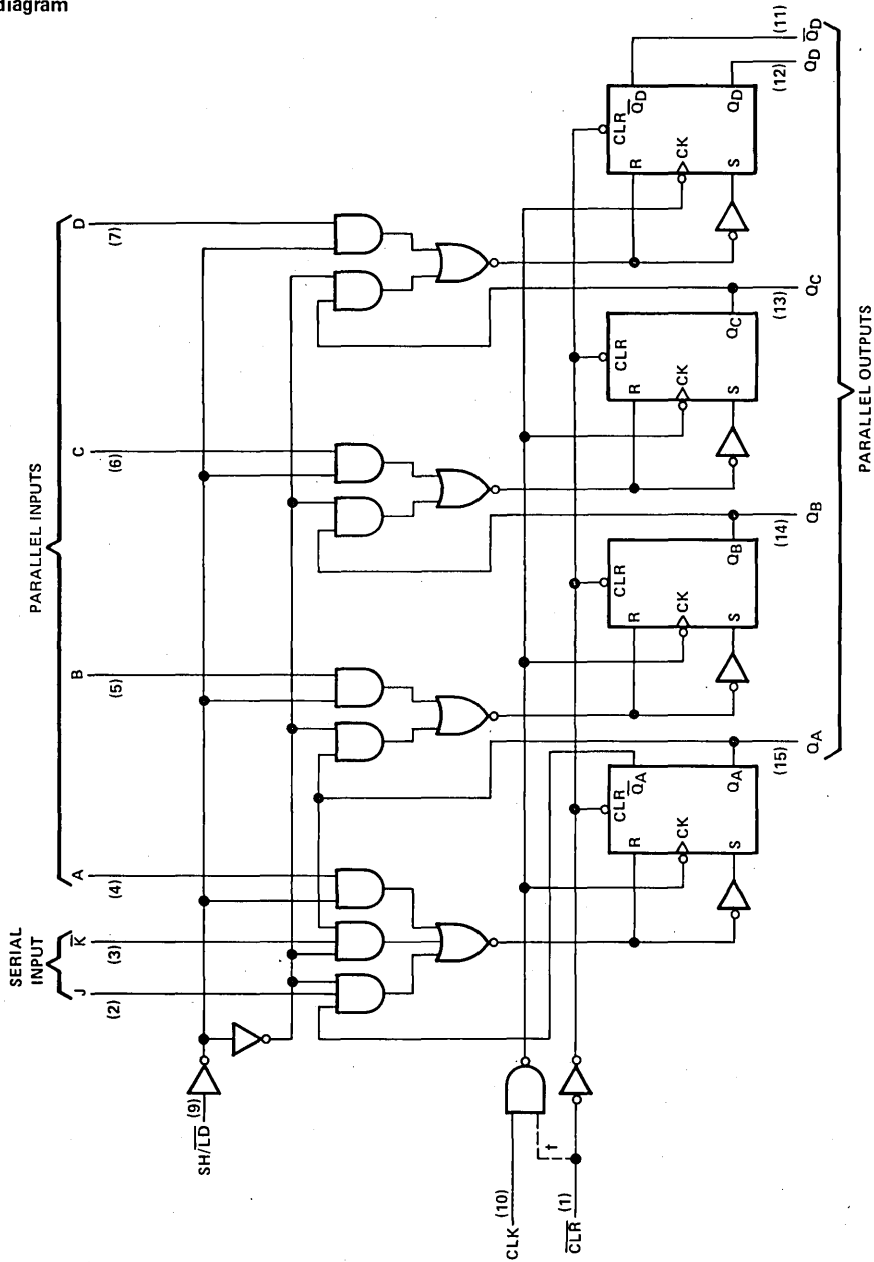

† This connection is made on '195 only.
 Pin numbers shown on logic notation are for D, J or N packages.

TYPES SN54195, SN54LS195A, SN54S195,
 SN74195, SN74LS195A, SN74S195
 4-BIT PARALLEL-ACCESS SHIFT REGISTERS

typical clear, shift, and load sequences

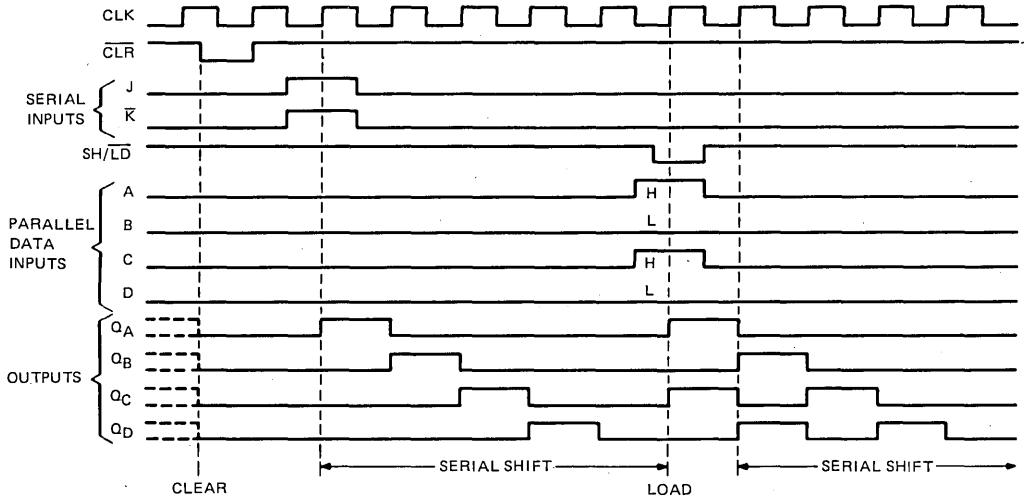

TTL DEVICES

TYPES SN54195, SN54LS195A, SN54S195, SN74195, SN74LS195A, SN74S195
4-BIT PARALLEL-ACCESS SHIFT REGISTERS

schematics of inputs and outputs

'195

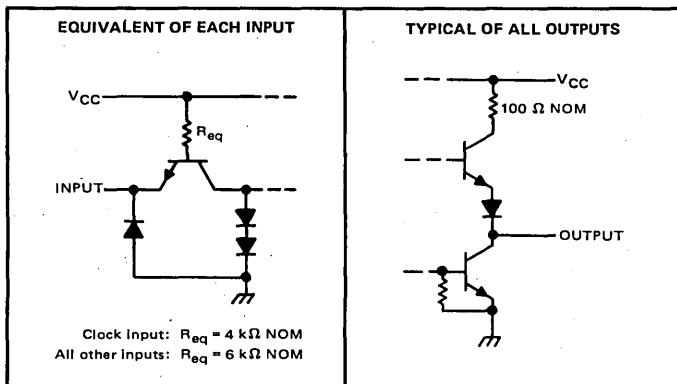

'LS195A

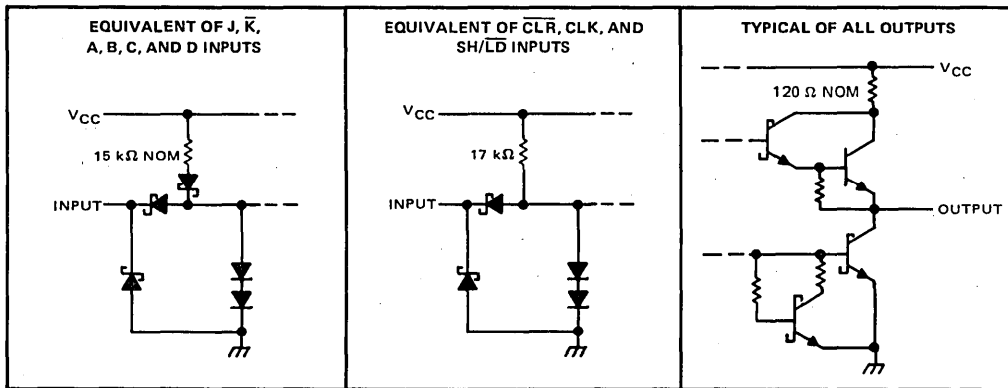

'S195

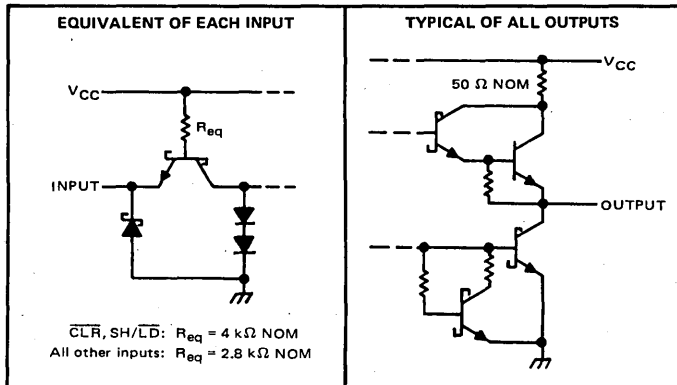

3

TTL DEVICES

TYPES SN54195, SN74195 4-BIT PARALLEL-ACCESS SHIFT REGISTERS

absolute maximum ratings over operating free-air temperature range (unless otherwise noted)

Supply voltage, V_{CC} (see Note 1)	7 V	
Input voltage	5.5 V	
Operating free-air temperature range: SN54195	-55°C to 125°C	
SN74195	0°C to 70°C	
Storage temperature range	-65°C to 150°C	

NOTE 1: Voltage values are with respect to network ground terminal.

recommended operating conditions

	SN54195			SN74195			UNIT
	MIN	NOM	MAX	MIN	NOM	MAX	
Supply voltage, V_{CC}	4.5	5	5.5	4.75	5	5.25	V
High-level output current, I_{OH}			-800			-800	μ A
Low-level output current, I_{OL}			16			16	mA
Clock frequency, f_{clock}	0		30	0		30	MHz
Width of clock input pulse, $t_w(\text{clock})$	16			16			ns
Width of clear input pulse, $t_w(\text{clear})$	12			12			ns
Setup time, t_{SU} (see Figure 1)	Shift/load		25	25			ns
	Serial and parallel data		20	20			
	Clear inactive-state		25	25			
Shift/load release time, $t_{release}$ (see Figure 1)			20			10	ns
Serial and parallel data hold time, t_H (see Figure 1)	0			0			ns
Operating free-air temperature, T_A	-55		125	0		70	°C

electrical characteristics over recommended operating free-air temperature range (unless otherwise noted)

PARAMETER	TEST CONDITIONS†	MIN	TYP‡	MAX	UNIT
V_{IH} High-level input voltage		2			V
V_{IL} Low-level input voltage				0.8	V
V_{IK} Input clamp voltage	$V_{CC} = \text{MIN}, I_I = -12 \text{ mA}$			-1.5	V
V_{OH} High-level output voltage	$V_{CC} = \text{MIN}, V_{IH} = 2 \text{ V}, V_{IL} = 0.8 \text{ V}, I_{OH} = -800 \mu\text{A}$	2.4	3.4		V
V_{OL} Low-level output voltage	$V_{CC} = \text{MIN}, V_{IH} = 2 \text{ V}, V_{IL} = 0.8 \text{ V}, I_{OL} = 16 \text{ mA}$		0.2	0.4	V
I_I Input current at maximum input voltage	$V_{CC} = \text{MAX}, V_I = 5.5 \text{ V}$			1	mA
I_{IH} High-level input current	$V_{CC} = \text{MAX}, V_I = 2.4 \text{ V}$			40	μ A
I_{IL} Low-level input current	$V_{CC} = \text{MAX}, V_I = 0.4 \text{ V}$			-1.6	mA
I_{OS} Short-circuit output current§	$V_{CC} = \text{MAX}$	SN54195	-20	-57	mA
		SN74195	-18	-57	
I_{CC} Supply current	$V_{CC} = \text{MAX},$ See Note 2		39	63	mA

† For conditions shown as MIN or MAX, use the appropriate value specified under recommended operating conditions.

‡ All typical values are at $V_{CC} = 5 \text{ V}, T_A = 25^\circ\text{C}$.

§ Not more than one output should be shorted at a time.

NOTE 2: With all outputs open, shift/load grounded, and 4.5 V applied to the J, \bar{K} , and data inputs, I_{CC} is measured by applying a momentary ground, followed by 4.5 V, to clear and then applying a momentary ground, followed by 4.5 V, to clock.

switching characteristics, $V_{CC} = 5 \text{ V}, T_A = 25^\circ\text{C}$

PARAMETER	TEST CONDITIONS	MIN	TYP	MAX	UNIT
f_{max} Maximum clock frequency	$C_L = 15 \text{ pF}, R_L = 400 \Omega,$ See Figure 1	30	39		MHz
t_{PHL} Propagation delay time, high-to-low-level output from clear			19	30	ns
t_{PLH} Propagation delay time, low-to-high-level output from clock			14	22	ns
t_{PHL} Propagation delay time, high-to-low-level output from clock			17	26	ns

TYPES SN54LS195A, SN74LS195A

4-BIT PARALLEL-ACCESS SHIFT REGISTERS

absolute maximum ratings over operating free-air temperature range (unless otherwise noted)

Supply voltage, V_{CC} (see Note 1)	7 V
Input voltage	7 V
Operating free-air temperature range: SN54LS195A	-55°C to 125°C
SN74LS195A	0°C to 70°C
Storage temperature range	-65°C to 150°C

NOTE 1: Voltage values are with respect to network ground terminal.

recommended operating conditions

	SN54LS195A			SN74LS195A			UNIT
	MIN	NOM	MAX	MIN	NOM	MAX	
Supply voltage, V_{CC}	4.5	5	5.5	4.75	5	5.25	V
High-level output current, I_{OH}			-400			-400	μ A
Low-level output current, I_{OL}			4			8	mA
Clock frequency, f_{clock}	0	30	0	30			MHz
Width of clock or clear pulse, $t_{w(clock)}$	16			16			ns
Width of clear input pulse, $t_{w(clear)}$	12			12			ns
Setup time, t_{SU} (see Figure 1)	Shift/load	25		25			ns
	Serial and parallel data	15		15			
	Clear inactive-state	25		25			
Shift/load release time, $t_{release}$ (see Figure 1)			20			20	ns
Serial and parallel data hold time, t_H (see Figure 1)	0			0			ns
Operating free-air temperature, T_A	-55	125		0	70		°C

electrical characteristics over recommended operating free-air temperature range (unless otherwise noted)

PARAMETER	TEST CONDITIONS†	SN54LS195A			SN74LS195A			UNIT
		MIN	TYP‡	MAX	MIN	TYP‡	MAX	
V_{IH} High-level input voltage		2			2			V
V_{IL} Low-level input voltage				0.7			0.8	V
V_{IK} Input clamp voltage	$V_{CC} = \text{MIN}, I_I = -18 \text{ mA}$			-1.5			-1.5	V
V_{OH} High-level output voltage	$V_{CC} = \text{MIN}, V_{IH} = 2 \text{ V}, V_{IL} = V_{IL \text{ max}}, I_{OH} = -400 \mu\text{A}$	2.5	3.4		2.7	3.4		V
V_{OL} Low-level output voltage	$V_{CC} = \text{MIN}, V_{IH} = 2 \text{ V}, V_{IL} = V_{IL \text{ max}}, I_{OL} = 4 \text{ mA}$ $I_{OL} = 8 \text{ mA}$		0.25	0.4		0.25	0.4	V
I_I Input current at maximum input voltage	$V_{CC} = \text{MAX}, V_I = 7 \text{ V}$			0.1			0.1	mA
I_{IH} High-level input current	$V_{CC} = \text{MAX}, V_I = 2.7 \text{ V}$			20			20	μ A
I_{IL} Low-level input current	$V_{CC} = \text{MAX}, V_I = 0.4 \text{ V}$			-0.4			-0.4	mA
I_{OS} Short-circuit output current§	$V_{CC} = \text{MAX}$	-20		-100	-20		-100	mA
I_{CC} Supply current	$V_{CC} = \text{MAX}, \text{ See Note 2}$		14	21		14	21	mA

† For conditions shown as MIN or MAX, use the appropriate value specified under recommended operating conditions.

‡ All typical values are at $V_{CC} = 5 \text{ V}, T_A = 25^\circ\text{C}$.

§ Not more than one output should be shorted at a time, and duration of the short-circuit should not exceed one second.

NOTE 2: With all outputs open, shift/load grounded, and 4.5 V applied to the J, K, and data inputs, I_{CC} is measured by applying a momentary ground, followed by 4.5 V, to clear and then applying a momentary ground, followed by 4.5 V, to clock.

switching characteristics, $V_{CC} = 5 \text{ V}, T_A = 25^\circ\text{C}$

PARAMETER	TEST CONDITIONS	MIN	TYP	MAX	UNIT
f_{max} Maximum clock frequency		30	39		MHz
t_{PHL} Propagation delay time, high-to-low-level output from clear	$C_L = 15 \text{ pF}, R_L = 2 \text{ k}\Omega,$ See Figure 1		19	30	ns
t_{PLH} Propagation delay time, low-to-high-level output from clock			14	22	ns
t_{PHL} Propagation delay time, high-to-low-level output from clock			17	26	ns

TYPES SN54S195, SN74S195 4-BIT PARALLEL-ACCESS SHIFT REGISTERS

absolute maximum ratings over operating free-air temperature range (unless otherwise noted)

Supply voltage, V_{CC} (see Note 1)	7 V	
Input voltage	5.5 V	
Operating free-air temperature range:	-55°C to 125°C	
SN54S195	-55°C to 125°C	
SN74S195	0°C to 70°C	
Storage temperature range	-65°C to 150°C	

NOTE 1: Voltage values are with respect to network ground terminal.

recommended operating conditions

	SN54S195			SN74S195			UNIT
	MIN	NOM	MAX	MIN	NOM	MAX	
Supply voltage, V_{CC}	4.5	5	5.5	4.75	5	5.25	V
High-level output current, I_{OH}			-1			-1	mA
Low-level output current, I_{OL}			20			20	mA
Clock frequency, f_{clock}	0		70	0		70	MHz
Width of clock input pulse, $t_{w(clock)}$		7			7		ns
Width of clear input pulse, $t_{w(clear)}$		12			12		ns
Setup time, t_{su} (see Figure 1)	Shift/load		11		11		ns
	Serial and parallel data		5		5		
	Clear inactive-state		9		9		
Shift/load release time, $t_{release}$ (see Figure 1)			6		6		ns
Serial and parallel data hold time, t_h (see Figure 1)		3			3		ns
Operating free-air temperature, T_A		-55	125		0	70	°C

electrical characteristics over recommended operating free-air temperature range (unless otherwise noted)

PARAMETER	TEST CONDITIONS†	MIN	TYP‡	MAX	UNIT
V_{IH} High-level input voltage			2		V
V_{IL} Low-level input voltage				0.8	V
V_{IK} Input clamp voltage	$V_{CC} = \text{MIN}, I_I = -18 \text{ mA}$			-1.2	V
V_{OH} High-level output voltage	$V_{CC} = \text{MIN}, V_{IH} = 2 \text{ V}, I_{OH} = -1 \text{ mA}$	SN54S195	2.5	3.4	V
	$V_{IL} = 0.8 \text{ V}, I_{OH} = -1 \text{ mA}$	SN74S195	2.7	3.4	
V_{OL} Low-level output voltage	$V_{CC} = \text{MIN}, V_{IH} = 2 \text{ V}, V_{IL} = 0.8 \text{ V}, I_{OL} = 20 \text{ mA}$			0.5	V
I_I Input current at maximum input voltage	$V_{CC} = \text{MAX}, V_I = 5.5 \text{ V}$			1	mA
I_{IH} High-level input current	$V_{CC} = \text{MAX}, V_I = 2.7 \text{ V}$			50	µA
I_{IL} Low-level input current	$V_{CC} = \text{MAX}, V_I = 0.5 \text{ V}$			-2	mA
I_{OS} Short-circuit output current §	$V_{CC} = \text{MAX}$		-40	-100	mA
I_{CC} Supply current	$V_{CC} = \text{MAX},$ See Note 2	SN54S195	70	99	mA
		SN74S195	70	109	

† For conditions shown as MIN or MAX, use the appropriate value specified under recommended operating conditions.

‡ All typical values are at $V_{CC} = 5 \text{ V}, T_A = 25^\circ \text{C}$.

§ Not more than one output should be shorted at a time, and duration of the short-circuit should not exceed one second.

NOTE 2: With all outputs open, shift/load grounded, and 4.5 V applied to the J, K, and data inputs, I_{CC} is measured by applying a momentary ground, followed by 4.5 V, to clear, and then applying a momentary ground, followed by 4.5 V, to clock.

switching characteristics, $V_{CC} = 5 \text{ V}, T_A = 25^\circ \text{C}$

PARAMETER	TEST CONDITIONS	MIN	TYP	MAX	UNIT
f_{max} Maximum clock frequency	$C_L = 15 \text{ pF},$ $R_L = 280 \Omega,$ See Figure 1	70	105		MHz
t_{PHL} Propagation delay time, high-to-low-level output from clear			12.5	18.5	ns
t_{PLH} Propagation delay time, low-to-high-level output from clock			8	12	ns
t_{PHL} Propagation delay time, high-to-low-level output from clock			11	16.5	ns

**TYPES SN54195, SN54LS195A, SN54S195,
SN74195, SN74LS195A, SN74S195
4-BIT PARALLEL-ACCESS SHIFT REGISTERS**

PARAMETER MEASUREMENT INFORMATION

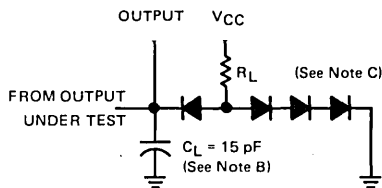

LOAD FOR OUTPUT UNDER TEST

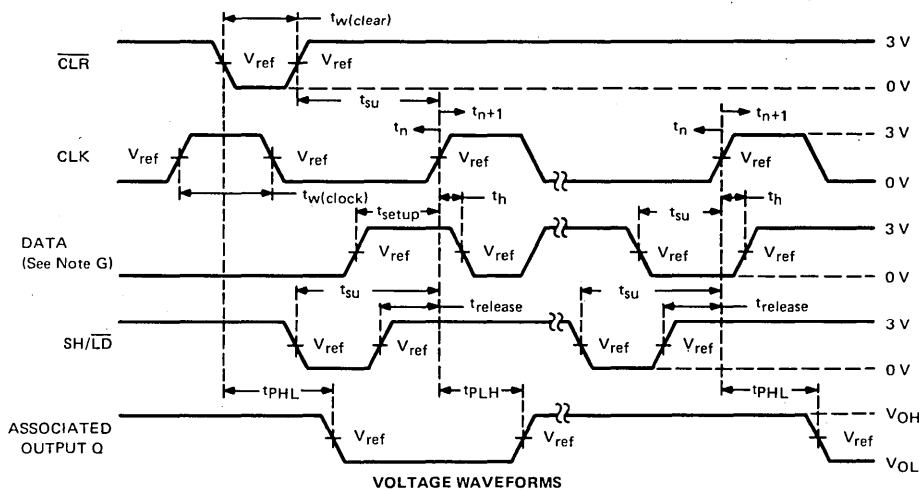

FIGURE 1—SWITCHING TIMES

- NOTES: A. The clock pulse generator has the following characteristics: $Z_{out} \approx 50 \Omega$ and $PRR \leq 1 \text{ MHz}$. For '195, $t_r \leq 7 \text{ ns}$ and $t_f \leq 7 \text{ ns}$. For 'LS195A, $t_r \leq 15 \text{ ns}$ and $t_f \leq 6 \text{ ns}$. For 'S195, $t_r = 2.5 \text{ ns}$ and $t_f = 2.5 \text{ ns}$. When testing t_{max} , vary the clock PRR.
- B. C_L includes probe and jig capacitance.
- C. All diodes are 1N3064 or equivalent.
- D. A clear pulse is applied prior to each test.
- E. For '195 and 'S195, $V_{ref} = 1.5 \text{ V}$; for 'LS195A, $V_{ref} = 1.3 \text{ V}$.
- F. Propagation delay times (t_{PLH} and t_{PHL}) are measured at t_{n+1} . Proper shifting of data is verified at t_{n+4} with a functional test.
- G. J and K inputs are tested the same as data A, B, C, and D inputs except that shift/load input remains high.
- H. t_n = bit time before clocking transition.
 t_{n+1} = bit time after one clocking transition.
 t_{n+4} = bit time after four clocking transitions.

TYPES SN54196, SN54197, SN54LS196, SN54LS197, SN54S196, SN54S197, SN74196, SN74197, SN74LS196, SN74LS197, SN74S196, SN74S197 50/30/100-MHz PRESETTABLE DECADE OR BINARY COUNTERS/LATCHES

OCTOBER 1976—REVISED APRIL 1985

- Performs BCD, Bi-Quinary, or Binary Counting
- Fully Programmable
- Fully Independent Clear Input
- Input Clamping Diodes Simplify System Design
- Output Q_A Maintains Full Fan-out Capability In Addition to Driving Clock-2 Input

SN54196, SN54LS196, SN54S196,
SN54197, SN54LS197, SN54S197 . . . J OR W PACKAGE
SN74196, SN74197 . . . J OR N PACKAGE
SN74LS196, SN74S196,
SN74LS197, SN74S197 . . . D, J OR N PACKAGE

(TOP VIEW)

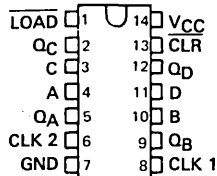

SN54LS196, SN54S196
SN54LS197, SN54S197 . . . FK PACKAGE
SN74LS196, SN74S196
SN74LS197, SN74S197 . . . FN PACKAGE

(TOP VIEW)

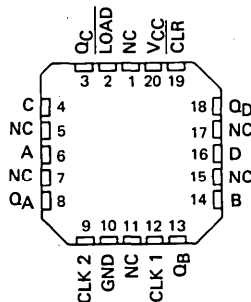

NC - No internal connection

TYPES	GUARANTEED COUNT FREQUENCY		TYPICAL POWER DISSIPATION
	CLOCK 1	CLOCK 2	
'196, '197	0-50 MHz	0-25 MHz	240 mW
'LS196, 'LS197	0-30 MHz	0-15 MHz	80 mW
'S196, 'S197	0-100 MHz	0-50 MHz	375 mW

description

These high-speed monolithic counters consist of four d-c coupled, master-slave flip-flops, which are internally interconnected to provide either a divide-by-two and a divide-by-five counter ('196, 'LS196, 'S196) or a divide-by-two and a divide-by-eight counter ('197, 'LS197, 'S197). These four counters are fully programmable; that is, the outputs may be preset to any state by placing a low on the count/load input and entering the desired data at the data inputs. The outputs will change to agree with the data inputs independent of the state of the clocks.

During the count operation, transfer of information to the outputs occurs on the negative-going edge of the clock pulse. These counters feature a direct clear which when taken low sets all outputs low regardless of the states of the clocks.

These counters may also be used as 4-bit latches by using the count/load input as the strobe and entering data at the data inputs. The outputs will directly follow the data inputs when the count/load is low, but will remain unchanged when the count/load is high and the clock inputs are inactive.

All inputs are diode-clamped to minimize transmission-line effects and simplify system design. These circuits are compatible with most TTL logic families. Series 54, 54LS, and 54S circuits are characterized for operation over the full military temperature range of -55°C to 125°C ; Series 74, 74LS, and 74S circuits are characterized for operation from 0°C to 70°C .

logic symbols†

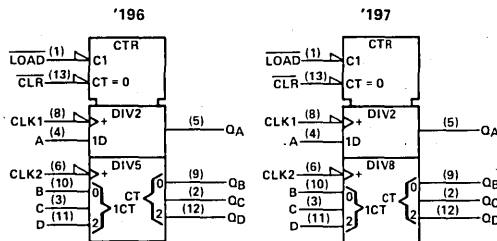

†Pin numbers shown on logic notation are for D, J or N packages.

PRODUCTION DATA
This document contains information current as of publication date. Products conform to specifications per the terms of Texas Instruments standard warranty. Production processing does not necessarily include testing of all parameters.

**TEXAS
INSTRUMENTS**

POST OFFICE BOX 225012 • DALLAS, TEXAS 75265

**TYPES SN54196, SN54197, SN54LS196, SN54LS197, SN54S196, SN54S197,
SN74196, SN74197, SN74LS196, SN74LS197, SN74S196, SN74S197
50/30/100-MHz PRESETTABLE DECADE OR BINARY COUNTERS/LATCHES**

typical count configurations

'196, 'LS196, and 'S196 typical count configurations and function tables are the same as those for '176.
'197, 'LS197, and 'S197 typical count configurations and function tables are the same as those for '177.

logic diagrams

'196, 'LS196, and 'S196 logic diagrams are the same as those for '176.
'197, 'LS197, and 'S197 logic diagrams are the same as those for '177.

schematics of inputs and outputs

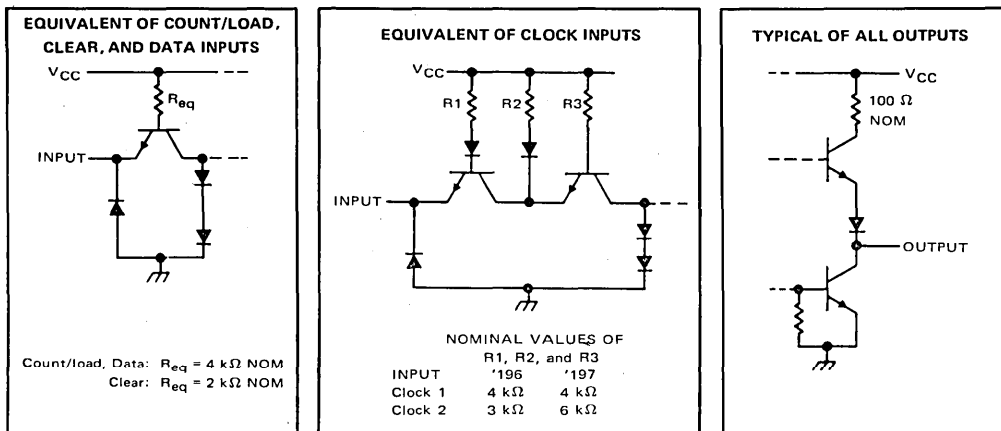

3 TTL DEVICES

TYPES SN54196, SN54197, SN74196, SN74197 50-MHz PRESETTABLE DECADE OR BINARY COUNTERS/LATCHES

absolute maximum ratings over operating free-air temperature range (unless otherwise noted)

Supply voltage, V_{CC} (see Note 1)	7 V
Input voltage	5.5 V
Intermitter voltage (see Note 2)	5.5 V
Operating free-air temperature range: SN54196, SN54197 Circuits	-55°C to 125°C
SN74196, SN74197 Circuits	0°C to 70°C
Storage temperature range	-65°C to 150°C

- NOTES: 1. Voltage values are with respect to network ground terminal.
 2. This is the voltage between two emitters of a multiple-emitter transistor. For this circuit, this rating applies between the clear and count/load inputs.

recommended operating conditions

		SN54196, SN54197			SN74196, SN74197			UNIT		
		MIN	NOM	MAX	MIN	NOM	MAX			
Supply voltage, V_{CC}		4.5	5	5.5	4.75	5	5.25	V		
High-level output current, I_{OH}		-800			-800			μ A		
Low-level output current, I_{OL}		16			16			mA		
Count frequency	Clock-1 input	0		50	0		50	MHz		
	Clock-2 input	0		25	0		25			
Pulse width, t_w	Clock-1 input	10			10			ns		
	Clock-2 input	20			20					
	Clear	15			15					
	Load	20			20					
Input hold time, t_h	High-level data	$t_w(\text{load})$			$t_w(\text{load})$			ns		
	Low-level data	$t_w(\text{load})$			$t_w(\text{load})$					
Input setup time, t_{SU} (see Note 4)	High-level data	10			10			ns		
	Low-level data	15			15					
Count enable time, t_{EN} (see Note 3)		20			20			ns		
Operating free-air temperature, T_A		-55			125			0	70	°C

- NOTES: 3. Minimum count enable time is the interval immediately preceding the negative-going edge of the clock pulse during which interval the count/load and clear inputs must both be high to ensure counting.
 4. t_{SU} is measured with respect to load input.

3
TTL DEVICES

TYPES SN54196, SN54197, SN74196, SN74197

50-MHz PRESETTABLE DECADE OR BINARY COUNTERS/LATCHES

electrical characteristics over recommended operating free-air temperature range (unless otherwise noted)

PARAMETER	TEST CONDITIONS†	SN54196, SN74196		SN54197, SN74197		UNIT	
		MIN	TYP‡ MAX	MIN	TYP‡ MAX		
V _{IH} High-level input voltage		2		2		V	
V _{IL} Low-level input voltage			0.8		0.8	V	
V _{IK} Input clamp voltage	V _{CC} = MIN, I _I = -12 mA		-1.5		-1.5	V	
V _{OH} High-level output voltage	V _{CC} = MIN, V _{IH} = 2 V, V _{IL} = 0.8 V, I _{OH} = -800 μA	2.4	3.4	2.4	3.4	V	
V _{OL} Low-level output voltage	V _{CC} = MIN, V _{IH} = 2 V, V _{IL} = 0.8 V, I _{OL} = 16 mA¶		0.2 0.4		0.2 0.4	V	
I _I Input current at maximum input voltage	V _{CC} = MAX, V _I = 5.5 V		1		1	mA	
I _{IH} High-level input current	Data, count/load		40		40	μA	
	Clear, clock 1	V _{CC} = MAX, V _I = 2.4 V			80		
	Clock 2		120		80		
I _{IL} Low-level input current	Data, count/load		-1.6		-1.6	mA	
	Clear	V _{CC} = MAX, V _I = 0.4 V			-3.2		
	Clock 1		-4.8		-4.8		
	Clock 2		-6.4		-3.2		
I _{OS} Short-circuit output current §	V _{CC} = MAX	SN54*	-20	-57	-20	-57	mA
		SN74*	-18	-57	-18	-57	
I _{CC} Supply current	V _{CC} = MAX, See Note 5	48	59	48	59	mA	

NOTE 5: I_{CC} is measured with all inputs grounded and all outputs open.

†For conditions shown as MIN or MAX, use the appropriate value specified under recommended operating conditions.

‡All typical values are at V_{CC} = 5 V, T_A = 25°C.

¶Q_A outputs are tested at I_{OL} = 16 mA plus the limit value of I_{IL} for the clock-2 input. This permits driving the clock-2 input while fanning out to 10 Series 54/74 loads.

§Not more than one output should be shorted at a time.

switching characteristics, V_{CC} = 5 V, T_A = 25°C

PARAMETER◇	FROM (INPUT)	TO (OUTPUT)	TEST CONDITIONS	SN54196			SN54197			UNIT
				SN74196	MIN	TYP	MAX	SN74197	MIN	
f _{max}	Clock 1	Q _A	C _L = 15 pF, R _L = 400 Ω, See Note 6	50	70		50	70		MHz
t _{PLH}	Clock 1	Q _A		7	12		7	12		ns
t _{PHL}				10	15		10	15		
t _{PLH}	Clock 2	Q _B		12	18		12	18		ns
t _{PHL}				14	21		14	21		
t _{PLH}	Clock 2	Q _C		24	36		24	36		ns
t _{PHL}				28	42		28	42		
t _{PLH}	Clock 2	Q _D		14	21		36	54		ns
t _{PHL}				12	18		42	63		
t _{PLH}	A, B, C, D	Q _A , Q _B , Q _C , Q _D		16	24		16	24		ns
t _{PHL}				25	38		25	38		
t _{PLH}	Load	Any		22	33		22	33		ns
t _{PHL}				24	36		24	36		
t _{PHL}	Clear	Any		25	37		25	37		ns

◇f_{max} ≡ maximum count frequency.

t_{PLH} ≡ propagation delay time, low-to-high-level output.

t_{PHL} ≡ propagation delay time, high-to-low-level output.

NOTE 6: Load circuit, input conditions, and voltage waveforms are the same as those shown for the '176, '177 except that testing f_{max}, V_{IL} = 0.3 V.

TYPES SN54LS196, SN54LS197, SN74LS196, SN74LS197 30-MHz PRESETTABLE DECADE OR BINARY COUNTERS/LATCHES

schematics of inputs and outputs

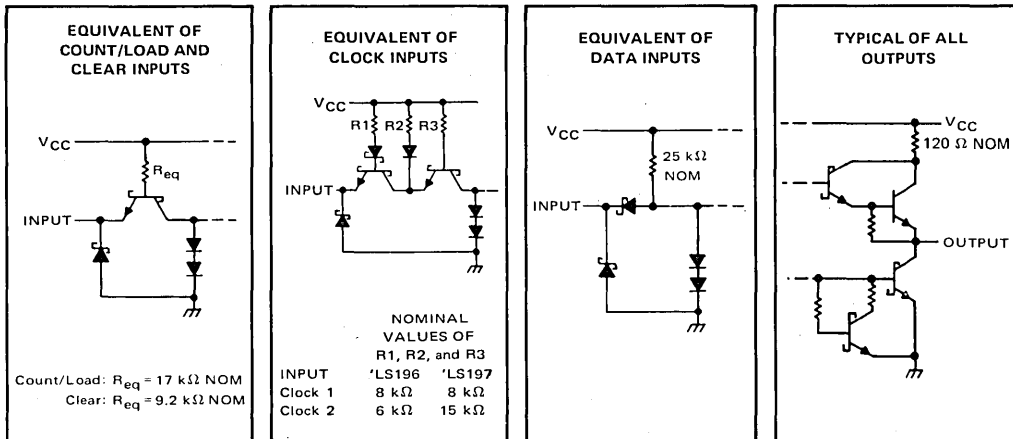

absolute maximum ratings over operating free-air temperature range (unless otherwise noted)

Supply voltage, V_{CC} (see Note 1)	7 V
Input voltage	5.5 V
Intermitter voltage (see Note 2)	5.5 V
Operating free-air temperature range: SN54LS196, SN54LS197 Circuits	-55°C to 125°C
SN74LS196, SN74LS197 Circuits	0°C to 70°C
Storage temperature range	-65°C to 150°C

- NOTES: 1. Voltage values are with respect to network ground terminal.
 2. This is the voltage between two emitters of a multiple-emitter transistor. For this circuit, this rating applies between the clear and count/load inputs.

recommended operating conditions

		SN54LS196, SN54LS197			SN74LS196, SN74LS197			UNIT	
		MIN	NOM	MAX	MIN	NOM	MAX		
V_{CC}	Supply voltage	4.5	5	5.5	4.75	5	5.25	V	
I_{OH}	High-level output current			-400			-400	μ A	
I_{OL}	Low-level output current			4			8	mA	
	Count frequency	Clock-1 input		0	30	0		30	MHz
		Clock-2 input		0	15	0		15	
t_w	Pulse width	Clock-1 input		20		20		ns	
		Clock-2 input		30		30			
		Clear		15		15			
		Load		20		20			
t_h	Input hold time	High-level data		10		10		ns	
		Low-level data		10		10			
t_{su}	Input setup time	High-level data		10		10		ns	
		Low-level data		15		15			
t_{enable}	Count enable time (see Note 3)	Clock 1		30		30		ns	
		Clock 2		50		50			
T_A	Operating free-air temperature	-55		125		0		70	°C

NOTE 3: Minimum count enable time is the interval immediately preceding the negative-going edge of the clock pulse during which interval the count/load and clear inputs must both be high to ensure counting.



TTL DEVICES

TYPES SN54LS196, SN54LS197, SN74LS196, SN74LS197

30-MHz PRESETTABLE DECADE OR BINARY COUNTERS/LATCHES

electrical characteristics over recommended operating free-air temperature range (unless otherwise noted)

PARAMETER		TEST CONDITIONS†	SN54LS196		SN74LS196		UNIT		
			SN54LS197		SN74LS197				
			MIN	TYP‡	MAX	MIN	TYP‡	MAX	
V_{IH} High-level input voltage			2			2			V
V_{IL} Low-level input voltage					0.7			0.8	V
V_{IK} Input clamp voltage		$V_{CC} = \text{MIN}, I_I = -18 \text{ mA}$			-1.5			-1.5	V
V_{OH} High-level output voltage		$V_{CC} = \text{MIN}, V_{IH} = 2 \text{ V},$ $V_{IL} = V_{IL \text{ max}}, I_{OH} = -400 \mu\text{A}$	2.5	3.4		2.7	3.4		V
V_{OL} Low-level output voltage		$V_{CC} = \text{MIN}, V_{IH} = 2 \text{ V},$ $V_{IL} = V_{IL \text{ max}}$			0.25	0.4	0.25	0.4	V
I_I Input current at maximum input voltage	Data, count/load	$V_{CC} = \text{MAX}, V_I = 5.5 \text{ V}$			0.1		0.1		mA
	Clear, clock 1				0.2		0.2		
	Clock 2 of 'LS196				0.4		0.4		
	Clock 2 of 'LS197				0.2		0.2		
I_{IH} High-level input current	Data, count/load	$V_{CC} = \text{MAX}, V_I = 2.7 \text{ V}$			20		20		μA
	Clear, clock 1				40		40		
	Clock 2 of 'LS196				80		80		
	Clock 2 of 'LS197				40		40		
I_{IL} Low-level input current	Data, count/load	$V_{CC} = \text{MAX}, V_I = 0.4 \text{ V}$			-0.4		-0.4		mA
	Clear				-0.8		-0.8		
	Clock 1				-2.4		-2.4		
	Clock 2 of 'LS196				-2.8		-2.8		
	Clock 2 of 'LS197				-1.3		-1.3		
I_{OS} Short-circuit output current§		$V_{CC} = \text{MAX}$	-20		-100	-20		-100	mA
I_{CC} Supply current		$V_{CC} = \text{MAX},$ See Note 4		16	27		16	27	mA

† For conditions shown as MIN or MAX, use the appropriate value specified under recommended operating conditions.

‡ All typical values are at $V_{CC} = 5 \text{ V}, T_A = 25^\circ\text{C}$.

§ Not more than one output should be shorted at a time, and duration of the short-circuit should not exceed one second.

¶ Q_A outputs are tested at specified I_{OL} plus the limit value of I_{IL} for the clock-2 input. This permits driving the clock-2 input while maintaining full fan-out capability.

NOTE 4: I_{CC} is measured with all inputs grounded and all outputs open.

switching characteristics, $V_{CC} = 5 \text{ V}, T_A = 25^\circ\text{C}$

PARAMETER◇	FROM (INPUT)	TO (OUTPUT)	TEST CONDITIONS	SN54LS196			SN54LS197			UNIT
				MIN	TYP	MAX	MIN	TYP	MAX	
f_{max}	Clock 1	Q_A	$C_L = 15 \text{ pF},$ $R_L = 2 \text{ k}\Omega,$ See Note 5	30	40		30	40		MHz
t_{PLH}	Clock 1	Q_A		8	15		8	15		ns
t_{PHL}				13	20		14	21		
t_{PLH}	Clock 2	Q_B		16	24		12	19		ns
t_{PHL}				22	33		23	35		
t_{PLH}	Clock 2	Q_C		38	57		34	51		ns
t_{PHL}				41	62		42	63		
t_{PLH}	Clock 2	Q_D		12	18		55	78		ns
t_{PHL}				30	45		63	95		
t_{PLH}	A, B, C, D	Q_A, Q_B, Q_C, Q_D		20	30		18	27		ns
t_{PHL}				29	44		29	44		
t_{PLH}	Load	Any		27	41		26	39		ns
t_{PHL}				30	45		30	45		
t_{PHL}	Clear	Any		34	51		34	51		ns

◇ f_{max} = maximum count frequency

‡ t_{PLH} = propagation delay time, low-to-high-level output, t_{PHL} = propagation delay time, high-to-low-level output

NOTE 5: Load circuit, input conditions, and voltage waveforms are the same as those shown for the '176, '177 except that $t_r \leq 15 \text{ ns}, t_f \leq 6 \text{ ns},$ and $V_{\text{ref}} = 1.3 \text{ V}$ (as opposed to 1.5 V)

3

TTL DEVICES

TYPES SN54S196, SN54S197, SN74S196, SN74S197 100-MHz PRESETTABLE DECADE AND BINARY COUNTERS/LATCHES

schematics of inputs and outputs

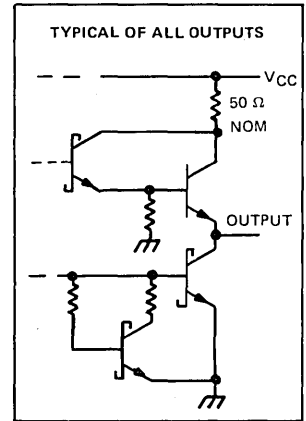
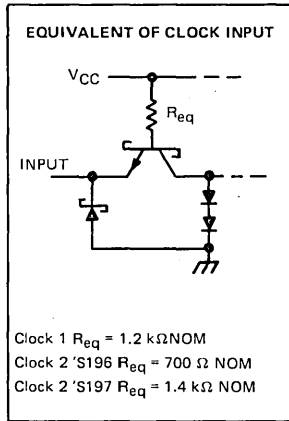
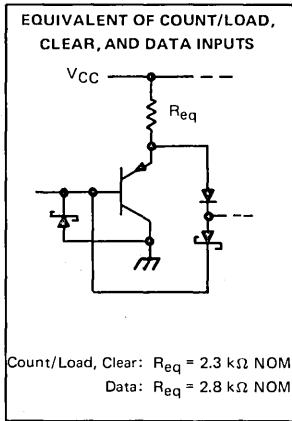

absolute maximum ratings over operating free-air temperature range (unless otherwise noted)

Supply voltage, V_{CC} (see Note 1)	7 V
Input voltage	5.5 V
Operating free-air temperature range: SN54S196, SN54S197 Circuits	-55°C to 125°C
SN74S196, SN74S197 Circuits	0°C to 70°C
Storage temperature range	-65°C to 150°C

NOTE 1: Voltage values are with respect to network ground terminal.

recommended operating conditions

		SN54S196, SN54S197			SN74S196, SN74S197			UNIT		
		MIN	NOM	MAX	MIN	NOM	MAX			
Supply voltage, V_{CC}		4.5	5	5.5	4.75	5	5.25	V		
High-level output current, I_{OH}								-1	mA	
Low-level output current, I_{OL}								20	mA	
Clock frequency	Clock-1 input	0			0			100	MHz	
	Clock-2 input	0			0			50		
Pulse width, t_W	Clock-1 input	5			5			ns		
	Clock-2 input	10			10					
	Clear	30			30					
	Load	5			5					
Input hold time, t_H	High-level data	3 \uparrow			3 \uparrow			ns		
	Low-level data	3 \uparrow			3 \uparrow					
Input setup time, t_{SU} (see Note 6)	High-level data	6 \uparrow			6 \uparrow			ns		
	Low-level data	6 \uparrow			6 \uparrow					
Count enable time, t_{EN} (see Note 2)		12			12			ns		
Operating free-air temperature, T_A		-55			125			0	70	°C

NOTES: 2. Minimum count enable time is the interval immediately preceding the negative-going edge of the clock pulse during which interval the count/load and clear inputs are both high to permit counting.

6. t_{SU} is measured with respect to load input.

3
TTL DEVICES

TYPES SN54S196, SN54S197, SN74S196, SN74S197
100-MHz PRESETTABLE DECADE AND BINARY COUNTERS/LATCHES

electrical characteristics over recommended operating free-air temperature range (unless otherwise noted)

PARAMETER	TEST CONDITIONS †	SN54S196, SN74S196			SN54S197, SN74S197			UNIT
		MIN	TYP‡	MAX	MIN	TYP‡	MAX	
V _{IH}		2			2			V
V _{IL}		0.8			0.8			V
V _{IK}	V _{CC} = MIN, I _I = -18 mA	-1.2			-1.2			V
V _{OH}	V _{CC} = MIN, V _{IH} = 2 V, V _{IL} = 0.8 V, I _{OH} = -1 mA	54S 74S	2.5 2.7	3.4 3.4	2.5 2.7	3.4 3.4	V	
V _{OL}	V _{CC} = MIN, V _{IH} = 2 V, V _{IL} = 0.8 V, I _{OL} = 20 mA	0.5			0.5			V
I _I	V _{CC} = MAX, V _I = 5.5 V	1			1			mA
I _{IH}	Clock 1, clock 2 All other inputs	150			150			µA
		50			50			
I _{IL}	Data, count/load Clear	-0.75			-0.75			mA
	Clock 1	-8			-8			mA
	Clock 2	-10			-6			mA
I _{OS} §	V _{CC} = MAX	-30	-110	-30	-110		mA	
I _{CC}	V _{CC} = MAX, See Note 3	54S	75	110	75	110	mA	
		74S	75	120	75	120		

† For conditions shown as MIN or MAX, use the appropriate value specified under recommended operating conditions.

‡ All typical values are at V_{CC} = 5 V, T_A = 25°C.

§ Q_A outputs are tested at I_{OL} = 20 mA plus the limit value of I_{IL} for the clock-2 input. This permits driving the clock-2 input while fanning out to 10 Series 54S/74S loads.

§ Not more than one output should be shorted at a time, and duration of the short-circuit should not exceed one second.

NOTE 3: I_{CC} is measured with all inputs grounded and all outputs open.

switching characteristics, V_{CC} = 5 V, T_A = 25°C

PARAMETER [◇]	(FROM INPUT)	TO (OUTPUT)	TEST CONDITIONS	SN54S196, SN74S196			SN54S197, SN74S197			UNIT
				MIN	TYP	MAX	MIN	TYP	MAX	
f _{max}	Clock 1	Q _A	R _L = 280 Ω, C _L = 15 pF, See Note 4	100	140		100	140		MHz
t _{PLH}	Clock 1	Q _A		5	10		5	10		ns
t _{PHL}				6	10		6	10		
t _{PLH}	Clock 2	Q _B		5	10		5	10		ns
t _{PHL}				8	12		8	12		
t _{PLH}	Clock 2	Q _C		12	18		12	18		ns
t _{PHL}				16	24		15	22		
t _{PLH}	Clock 2	Q _D		5	10		18	27		ns
t _{PHL}				8	12		22	33		
t _{PLH}	A,B,C,D	Q _A ,Q _B ,Q _C ,Q _D		7	12		7	12		ns
t _{PHL}				12	18		12	18		
t _{PLH}	Load	Any		10	18		10	18		ns
t _{PHL}				12	18		12	18		
t _{PHL}	Clear	Any		26	37		26	37		ns

◇ f_{max} = maximum input county frequency.

t_{PLH} = propagation delay time, low-to-high-level output.

t_{PHL} = propagation delay time, high-to-low-level output.

NOTE 4: See General Information Section for load circuits and voltage waveforms.

3 TTL DEVICES

TYPES SN54198, SN54199, SN74198, SN74199 8-BIT SHIFT REGISTERS

DECEMBER 1972—REVISED DECEMBER 1983

description

These 8-bit shift registers are compatible with most other TTL and MSI logic families. All inputs are buffered to lower the drive requirements to one normalized Series 54/74 load, and input clamping diodes minimize switching transients to simplify system design. Maximum input clock frequency is typically 35 megahertz and power dissipation is typically 360 mW.

Series 54 devices are characterized for operation over the full military temperature range of -55°C to 125°C ; Series 74 devices are characterized for operation from 0°C to 70°C .

SN54198 and SN74198

These bidirectional registers are designed to incorporate virtually all of the features a system designer may want in a shift register. These circuits contain 87 equivalent gates and feature parallel inputs, parallel outputs, right-shift and left-shift serial inputs, operating-mode-control inputs, and a direct overriding clear line. The register has four distinct modes of operation, namely:

- Inhibit Clock (Do nothing)
- Shift Right (In the direction Q_A toward Q_H)
- Shift Left (In the direction Q_H toward Q_A)
- Parallel (Broadside) Load

Synchronous parallel loading is accomplished by applying the eight bits of data and taking both mode control inputs, S_0 and S_1 , high. The data is loaded into the associated flip-flop and appears at the outputs after the positive transition of the clock input. During loading, serial data flow is inhibited.

Shift right is accomplished synchronously with the rising edge of the clock pulse when S_0 is high and S_1 is low. Serial data for this mode is entered at the shift-right data input. When S_0 is low and S_1 is high, data shifts left synchronously and new data is entered at the shift-left serial input.

Clocking of the flip-flop is inhibited when both mode control inputs are low. The mode controls should be changed only while the clock input is high.

'198
FUNCTION TABLE

CLEAR		MODE		INPUTS			OUTPUTS					
		S_1	S_0	CLOCK	SERIAL		PARALLEL	Q_A	Q_B	...	Q_G	Q_H
			LEFT		RIGHT	A...H						
L	X	X	X	X	X	X	X	L	L	L	L	L
H	X	X	L	X	X	X	X	Q_{A0}	Q_{B0}		Q_{G0}	Q_{H0}
H	H	H	↑	X	X	a...h	X	a	b		g	h
H	L	H	↑	X	H	X	X	H	Q_{An}		Q_{Fn}	Q_{Gn}
H	L	H	↑	X	L	X	X	L	Q_{An}		Q_{Fn}	Q_{Gn}
H	H	L	↑	H	X	X	X	Q_{Bn}	Q_{Cn}		Q_{Hn}	H
H	H	L	↑	L	X	X	X	Q_{Bn}	Q_{Cn}		Q_{Hn}	L
H	L	L	X	X	X	X	X	Q_{A0}	Q_{B0}		Q_{G0}	Q_{H0}

H = high level (steady state), L = low level (steady state)

X = irrelevant (any input, including transitions)

↑ = transition from low to high level

a...h = the level of steady-state input at inputs A thru H, respectively.

Q_{A0} , Q_{B0} , Q_{G0} , Q_{H0} = the level of Q_A , Q_B , Q_G , or Q_H , respectively, before the indicated steady-state input conditions were established.

Q_{An} , Q_{Bn} , etc. = the level of Q_A , Q_B , etc., respectively, before the most-recent ↑ transition of the clock.

SN54198 ... J OR W PACKAGE
SN74198 ... J OR N PACKAGE
(TOP VIEW)

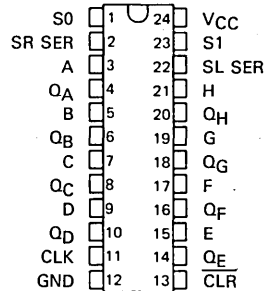

PRODUCTION DATA
This document contains information current as of publication date. Products conform to specifications per the terms of Texas Instruments standard warranty. Production processing does not necessarily include testing of all parameters.

**TEXAS
INSTRUMENTS**

POST OFFICE BOX 225012 • DALLAS, TEXAS 75265

TTL DEVICES

3

TYPES SN54198, SN54199, SN74198, SN74199 8-BIT SHIFT REGISTERS

SN54199 and SN74199

These registers feature parallel inputs, parallel outputs, J-K serial inputs, shift/load control input, a direct overriding clear line, and gated clock inputs. The register has three modes of operation:

- Inhibit Clock (Do nothing)
- Shift (In the direction Q_A toward Q_H)
- Parallel (Broadside) Load

Parallel loading is accomplished by applying the eight bits of data and taking the shift/load control input low when the clock input is not inhibited. The data is loaded into the associated flip-flop and appears at the outputs after the positive transition of the clock input. During loading, serial data flow is inhibited.

Shifting is accomplished synchronously when shift/load is high and the clock input is not inhibited. Serial data for this mode is entered at the J-K inputs. See the function table for levels required to enter serial data into the first flip-flop.

Both of the clock inputs are identical in function and may be used interchangeably to serve as clock or clock-inhibit inputs. Holding either high inhibits clocking, but when one is held low, a clock input applied to the other input is passed to the eight flip-flops of the register. The clock-inhibit input should be changed to the high level only while the clock input is high.

These shift registers contain the equivalent of 79 TTL gates. Average power dissipation per gate is typically 4.55 mW.

SN54199 . . . J OR W PACKAGE
SN74199 . . . J OR N PACKAGE
(TOP-VIEW)

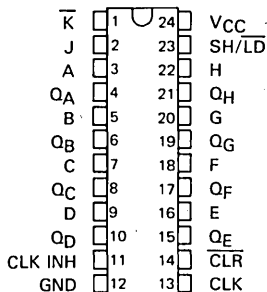

199
FUNCTION TABLE

INPUTS						OUTPUTS			
CLEAR	SHIFT/ LOAD	CLOCK INHIBIT	CLOCK	SERIAL J \bar{K}	PARALLEL A . . . H	Q_A	Q_B	Q_C . . .	Q_H
L	X	X	X	X X	X	L	L	L	L
H	X	L	L	X X	X	Q_{A0}	Q_{B0}	Q_{C0}	Q_{H0}
H	L	L	↑	X X	a . . . h	a	b	c	h
H	H	L	↑	L H	X	Q_{A0}	Q_{A0}	Q_{Bn}	Q_{Gn}
H	H	L	↑	L L	X	L	Q_{An}	Q_{Bn}	Q_{Gn}
H	H	L	↑	H H	X	H	Q_{An}	Q_{Bn}	Q_{Gn}
H	H	L	↑	H L	X	\bar{Q}_{An}	Q_{An}	Q_{Bn}	Q_{Gn}
H	X	H	↑	X X	X	Q_{A0}	Q_{B0}	Q_{B0}	Q_{H0}

schematics of inputs and outputs

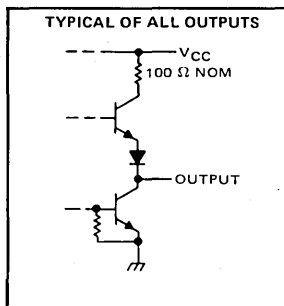
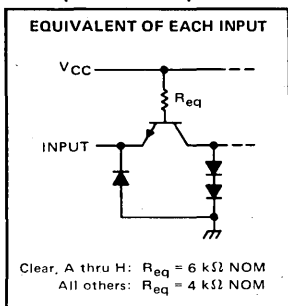

TYPES SN54198, SN74198
8-BIT SHIFT REGISTERS

logic diagram

'198

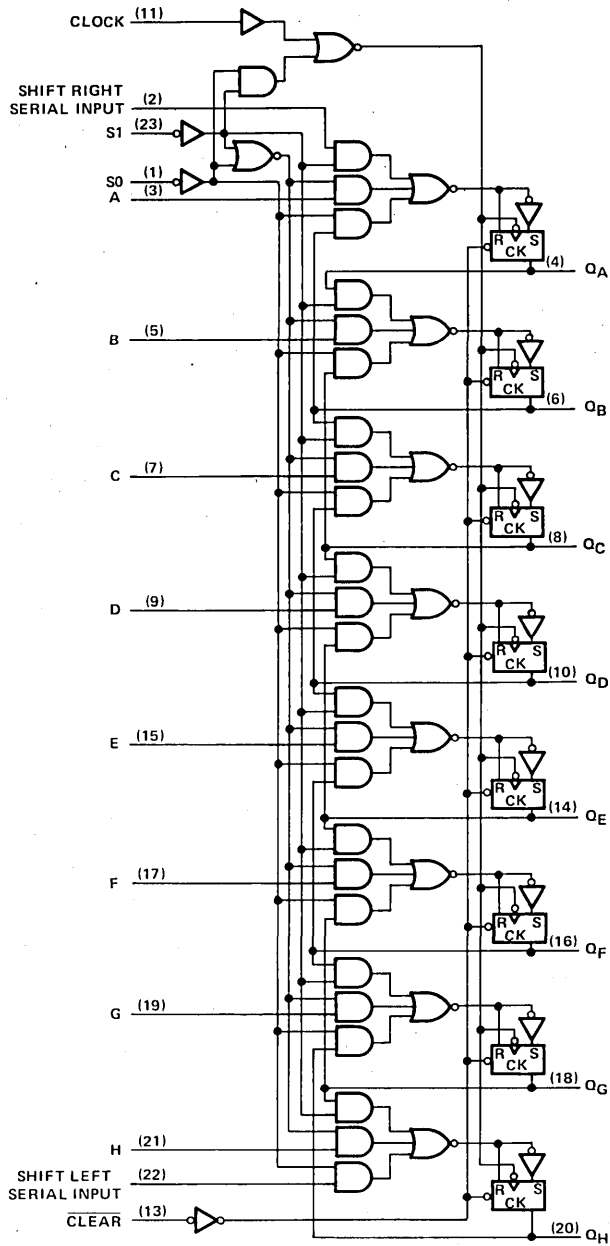

Pin numbers shown on logic notation are for J or N packages.

TYPES SN54199, SN74199
8-BIT SHIFT REGISTERS

logic diagram

'199

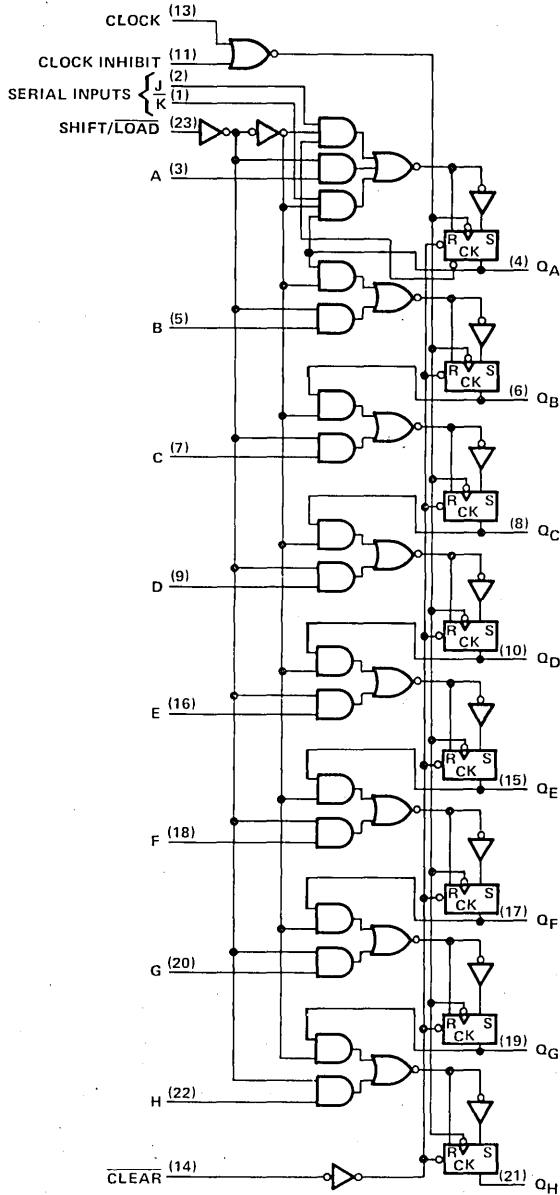

Pin numbers shown on logic notation are for J or N packages.

3

TTL DEVICES

**TYPES SN54198, SN74198
8-BIT SHIFT REGISTERS**

SN54198, SN74198

typical clear, load, right-shift, left-shift, inhibit, and clear sequences

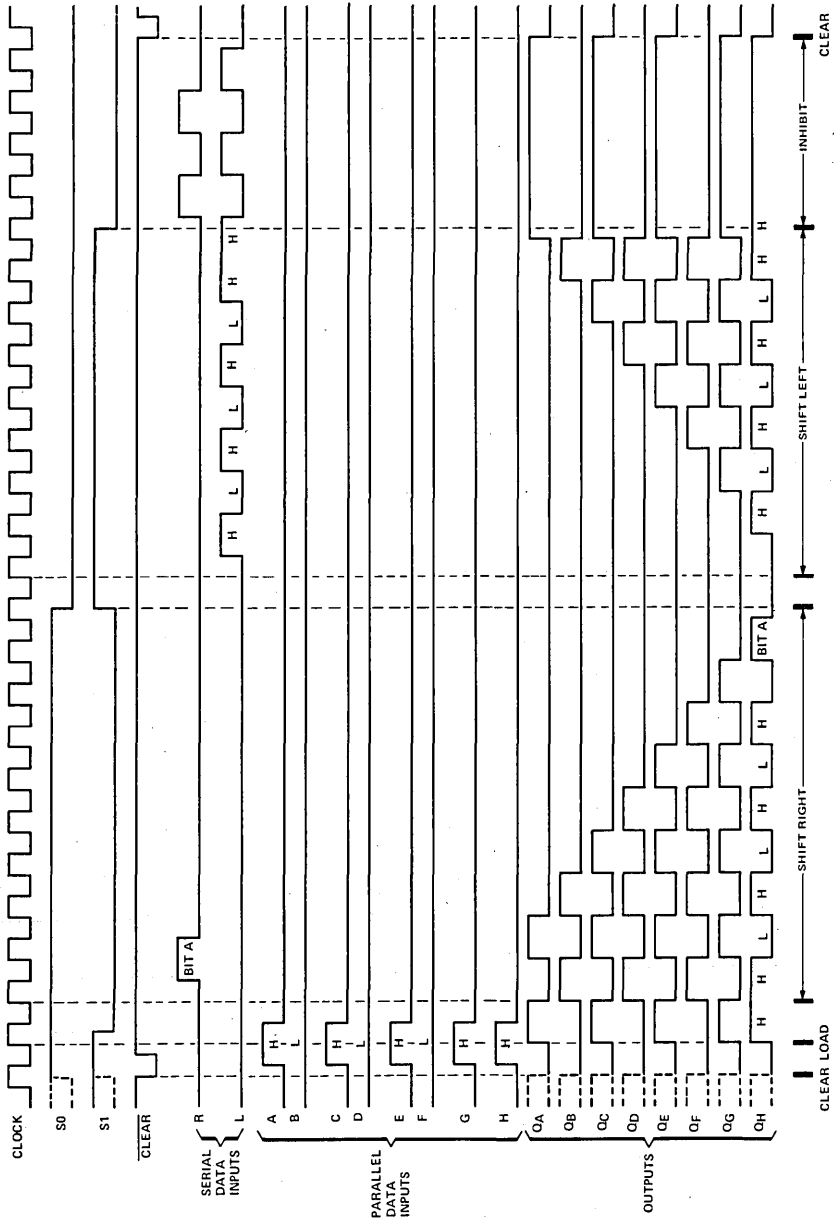

TYPES SN54199, SN74199
8-BIT SHIFT REGISTERS

SN54199, SN74199

typical clear, shift, load, and inhibit sequences

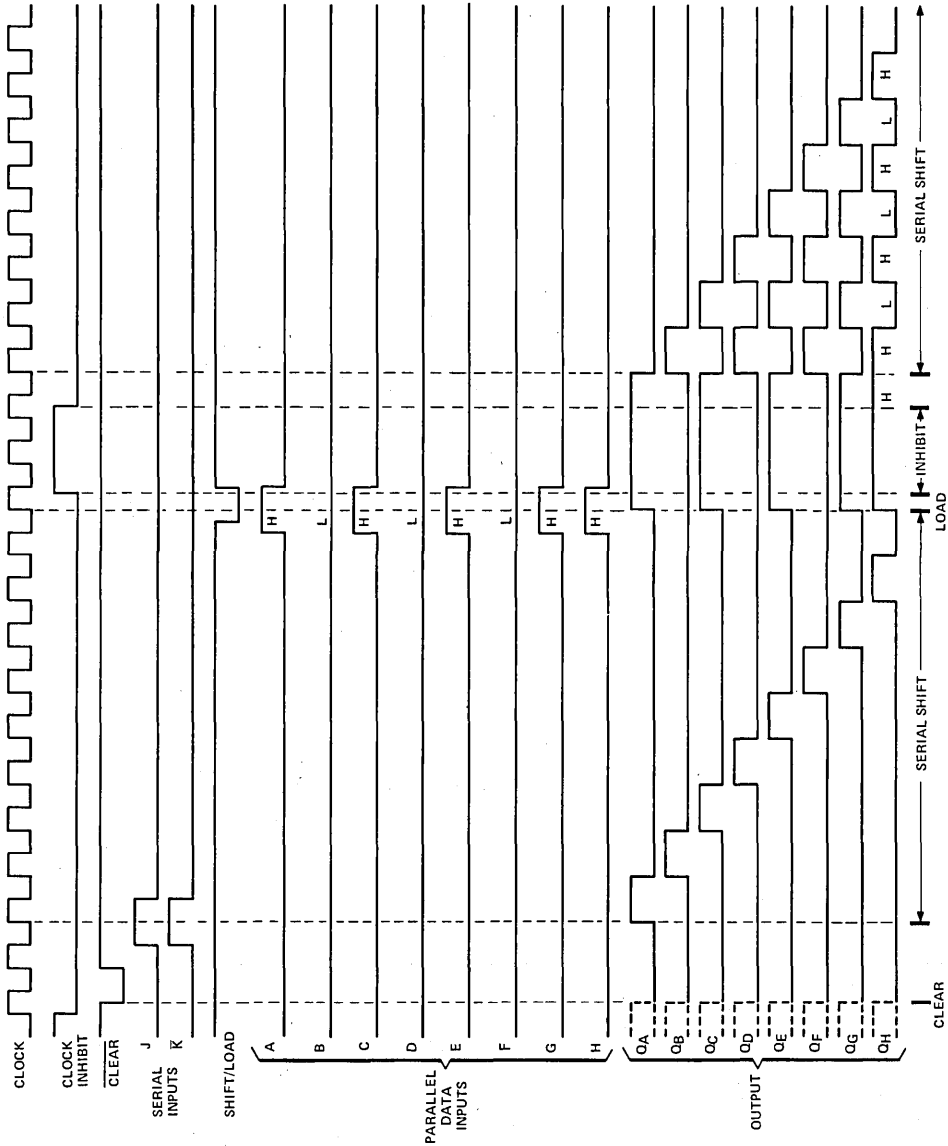

TYPES SN54198, SN54199, SN74198, SN74199 8-BIT SHIFT REGISTERS

absolute maximum ratings over operating free-air temperature range (unless otherwise noted)

Supply voltage, V_{CC} (see Note 1)	7 V
Input voltage	5.5 V
Operating free-air temperature range: SN54' Circuits	-55°C to 125°C
SN74' Circuits	0°C to 70°C
Storage temperature range	-65°C to 150°C

NOTE 1: Voltage values are with respect to network ground terminal.

recommended operating conditions

	SN54198 SN54199			SN74198 SN74199			UNIT
	MIN	NOM	MAX	MIN	NOM	MAX	
Supply voltage, V_{CC}	4.5	5	5.5	4.75	5	5.25	V
High-level output current, I_{OH}			-800			-800	μ A
Low-level output current, I_{OL}			16			16	mA
Clock frequency, f_{clock}	0		25	0		25	MHz
Width of clock or clear pulse, t_w (see Figure 1)		20			20		ns
Mode-control setup time, t_{su}		30			30		ns
Data setup time, t_{su} (see Figure 1)		20			20		ns
Hold time at any input, t_h (see Figure 1)		0			0		ns
Operating free-air temperature, T_A	-55		125	0		70	°C

electrical characteristics over recommended operating free-air temperature range (unless otherwise noted)

PARAMETER	TEST CONDITIONS†	SN54198 SN54199			SN74198 SN74199			UNIT
		MIN	TYP‡	MAX	MIN	TYP‡	MAX	
V_{IH} High-level input voltage		2			2			V
V_{IL} Low-level input voltage				0.8			0.8	V
V_{IK} Input clamp voltage	$V_{CC} = \text{MIN}, I_I = -12 \text{ mA}$			-1.5			-1.5	V
V_{OH} High-level output voltage	$V_{CC} = \text{MIN}, V_{IH} = 2 \text{ V}, V_{IL} = 0.8 \text{ V}, I_{OH} = -800 \mu\text{A}$	2.4	3.4		2.4	3.4		V
V_{OL} Low-level output voltage	$V_{CC} = \text{MIN}, V_{IH} = 2 \text{ V}, V_{IL} = 0.8 \text{ V}, I_{OL} = 16 \text{ mA}$		0.2 0.4			0.2 0.4		V
I_I Input current at maximum input voltage	$V_{CC} = \text{MAX}, V_I = 5.5 \text{ V}$			1			1	mA
I_{IH} High-level input current	$V_{CC} = \text{MAX}, V_I = 2.4 \text{ V}$			40			40	μ A
I_{IL} Low-level input current	$V_{CC} = \text{MAX}, V_I = 0.4 \text{ V}$			-1.6			-1.6	mA
I_{OS} Short-circuit output current§	$V_{CC} = \text{MAX}$	-20		-57	-18		-57	mA
I_{CC} Supply current	$V_{CC} = \text{MAX}$, See Table Below		90 127			90 127		mA

† For conditions shown as MIN or MAX, use the appropriate value specified under recommended operating conditions.

‡ All typical values are at $V_{CC} = 5 \text{ V}, T_A = 25^\circ\text{C}$

§ Not more than one output should be shorted at a time.

TEST CONDITIONS FOR I_{CC} (ALL OUTPUTS ARE OPEN)

TYPE	APPLY 4.5 V	FIRST GROUND, THEN APPLY 4.5 V	GROUND
SN54198, SN74198	Serial Input, S_0, S_1	Clock	Clear, Inputs A thru H
SN54199, SN74199	J, K, Inputs A thru H	Clock	Clock inhibit, Clear, Shift/Load

3

TTL DEVICES

TYPES SN54198, SN54199, SN74198, SN74199
8-BIT SHIFT REGISTERS

switching characteristics, $V_{CC} = 5\text{ V}$, $T_A = 25^\circ\text{C}$

PARAMETER	TEST CONDITIONS	MIN	TYP	MAX	UNIT
f_{max} Maximum clock frequency	$C_L = 15\text{ pF}$, $R_L = 400\ \Omega$, See Figure 1	25	35		MHz
t_{PHL} Propagation delay time, high-to-low-level output from clear			23	35	ns
t_{PHL} Propagation delay time, high-to-low-level output from clock			20	30	ns
t_{PLH} Propagation delay time, low-to-high-level output from clock			17	26	ns

3

TTL DEVICES

PARAMETER MEASUREMENT INFORMATION

SN54198, SN74198
TEST TABLE FOR SYNCHRONOUS INPUTS

DATA INPUT FOR TEST	S1	S0	OUTPUT TESTED (SEE NOTE E)
A	4.5 V	4.5 V	Q _A at t _{n+1}
B	4.5 V	4.5 V	Q _B at t _{n+1}
C	4.5 V	4.5 V	Q _C at t _{n+1}
D	4.5 V	4.5 V	Q _D at t _{n+1}
E	4.5 V	4.5 V	Q _E at t _{n+1}
F	4.5 V	4.5 V	Q _F at t _{n+1}
G	4.5 V	4.5 V	Q _G at t _{n+1}
H	4.5 V	4.5 V	Q _H at t _{n+1}
L Serial Input	4.5 V	0 V	Q _A at t _{n+8}
R Serial Input	0 V	4.5 V	Q _H at t _{n+8}

SN54199, SN74199
TEST TABLE FOR SYNCHRONOUS INPUTS

DATA INPUT FOR TEST	SHIFT/LOAD	OUTPUT TESTED (SEE NOTE E)
A	0 V	Q _A at t _{n+1}
B	0 V	Q _B at t _{n+1}
C	0 V	Q _C at t _{n+1}
D	0 V	Q _D at t _{n+1}
E	0 V	Q _E at t _{n+1}
F	0 V	Q _F at t _{n+1}
G	0 V	Q _G at t _{n+1}
H	0 V	Q _H at t _{n+1}
J and \bar{K}	4.5 V	Q _H at t _{n+8}

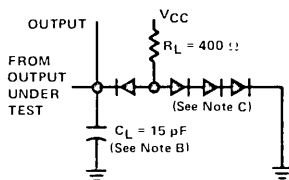

LOAD FOR OUTPUT UNDER TEST

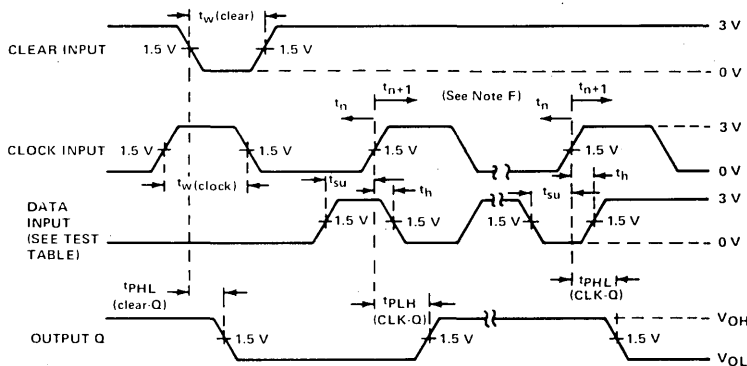

VOLTAGE WAVEFORMS

- NOTES: A. The clock pulse has the following characteristics: $t_w(\text{clock}) > 20$ ns and $\text{PRR} = 1$ MHz. The clear pulse has the following characteristics: $t_w(\text{clear}) > 20$ ns and $t_{\text{hold}} = 0$ ns. When testing t_{max} , vary the clock PRR.
- B. C_L includes probe and jig capacitance.
- C. All diodes are 1N3064.
- D. A clear pulse is applied prior to each test.
- E. Propagation delay times (t_{PLH} and t_{PHL}) are measured at t_{n+1} . Proper shifting of data is verified at t_{n+8} with a functional test.
- F. t_n = bit time before clocking transition
 t_{n+1} = bit time after one clocking transition
 t_{n+8} = bit time after eight clocking transitions

FIGURE 1

TYPES SN54221, SN54LS221, SN74221, SN74LS221 DUAL MONOSTABLE MULTIVIBRATORS WITH SCHMITT-TRIGGER INPUTS

REVISED DECEMBER 1983

- **SN54221, SN54LS221, SN74221 and SN74LS221 Are Dual Versions of Highly Stable SN54121, SN74121 One-Shots on a Monolithic Chip**
- **SN54221 and SN74221 Demonstrate Electrical and Switching Characteristics That Are Virtually Identical to the SN54121, SN74121 One-Shots**
- **Pin-Out Is Identical to the SN54123, SN74123, SN54LS123, SN74LS123**
- **Overriding Clear Terminates Output Pulse**

SN54221, SN54LS221 ... J OR W PACKAGE
SN74221 ... J OR N PACKAGE
SN74LS221 ... D, J OR N PACKAGE
(TOP VIEW)

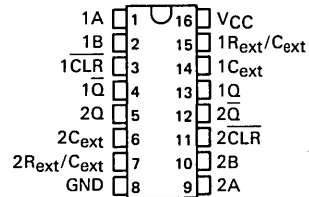

SN54LS221 ... FK PACKAGE
SN74LS221 ... FN PACKAGE
(TOP VIEW)

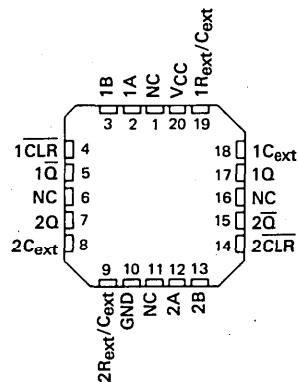

TYPE	TYPICAL POWER DISSIPATION	MAXIMUM OUTPUT PULSE LENGTH
SN54221	130 mW	21 s
SN74221	130 mW	28 s
SN54LS221	23 mW	49 s
SN74LS221	23 mW	70 s

description

The '221 and 'LS221 are monolithic dual multivibrators with performance characteristics virtually identical to those of the '121. Each multivibrator features a negative-transition-triggered input and a positive-transition-triggered input either of which can be used as an inhibit input.

Pulse triggering occurs at a particular voltage level and is not directly related to the transition time of the input pulse. Schmitt-trigger input circuitry (TTL hysteresis) for B input allows jitter-free triggering from inputs with transition rates as slow as 1 volt/second, providing the circuit with excellent noise immunity of typically 1.2 volts. A high immunity to V_{CC} noise of typically 1.5 volts is also provided by internal latching circuitry.

Once fired, the outputs are independent of further transitions of the A and B inputs and are a function of the timing components, or the output pulses can be terminated by the overriding clear. Input pulses may be of any duration relative to the output pulse. Output pulse length may be varied from 35 nanoseconds to the maximums shown in the above table by choosing appropriate timing components. With $R_{ext} = 2 \text{ k}\Omega$ and $C_{ext} = 0$, an output pulse of typically 30 nanoseconds is achieved which may be used as a d-c-triggered reset signal. Output rise and fall times are TTL compatible and independent of pulse length. Typical triggering and clearing sequences are illustrated as a part of the switching characteristics waveforms.

FUNCTION TABLE
(EACH MONOSTABLE)

INPUTS			OUTPUTS	
CLEAR	A	B	Q	\bar{Q}
L	X	X	L	H
X	H	X	L	H
X	X	L	L	H
H	L	\uparrow		
H	\downarrow	H		
\uparrow^*	L	H		

Also see description and switching characteristics

* This condition is true only if the output of the latch formed by the two NAND gates has been conditioned to the logical "1" state prior to CLR going high. This latch is conditioned by taking either A high or B low which \bar{CLR} is in the inactive state.

PRODUCTION DATA
This document contains information current as of publication date. Products conform to specifications per the terms of Texas Instruments standard warranty. Production processing does not necessarily include testing of all parameters.

TEXAS
INSTRUMENTS

POST OFFICE BOX 225012 • DALLAS, TEXAS 75265

3-805

TYPES SN54221, SN54LS221, SN74221, SN74LS221 DUAL MONOSTABLE MULTIVIBRATORS WITH SCHMITT-TRIGGER INPUTS

description (continued)

Pulse width stability is achieved through internal compensation and is virtually independent of V_{CC} and temperature. In most applications, pulse stability will only be limited by the accuracy of external timing components.

Jitter-free operation is maintained over the full temperature and V_{CC} ranges for more than six decades of timing capacitance (10 pF to 10 μ F) and more than one decade of timing resistance (2 k Ω to 30 k Ω for the SN54221, 2 k Ω to 40 k Ω for the SN74221, 2 k Ω to 70 k Ω for the SN54LS221, and 2 k Ω to 100 k Ω for the SN74LS221). Throughout these ranges, pulse width is defined by the relationship: $t_w(\text{out}) = C_{\text{ext}}R_{\text{ext}} \ln 2 \approx 0.7 C_{\text{ext}}R_{\text{ext}}$. In circuits where pulse cutoff is not critical, timing capacitance up to 1000 μ F and timing resistance as low as 1.4 k Ω may be used. Also, the range of jitter-free output pulse widths is extended if V_{CC} is held to 5 volts and free-air temperature is 25°C. Duty cycles as high as 90% are achieved when using maximum recommended R_T . Higher duty cycles are available if a certain amount of pulse-width jitter is allowed.

The variance in output pulse width from device to device is typically less than $\pm 0.5\%$ for given external timing components. An example of this distribution for the '221 is shown in Figure 2. Variations in output pulse width versus supply voltage and temperature for the '221 are shown in Figure 3 and 4, respectively.

Pin assignments for these devices are identical to those of the SN54123/SN74123 or SN54LS123/SN74LS123 so that the '221 or 'LS221 can be substituted for those products in systems not using the retrigger by merely changing the value of R_{ext} and/or C_{ext} , however the polarity of the capacitor will have to be changed.

TIMING COMPONENT CONNECTIONS

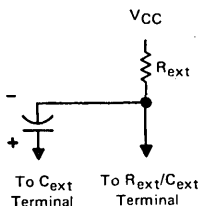

NOTE: Due to the internal circuit, the $R_{\text{ext}}/C_{\text{ext}}$ pin will never be more positive than the C_{ext} pin.
Pin numbers shown on logic notation are for D, J or N packages.

LOGIC SYMBOL

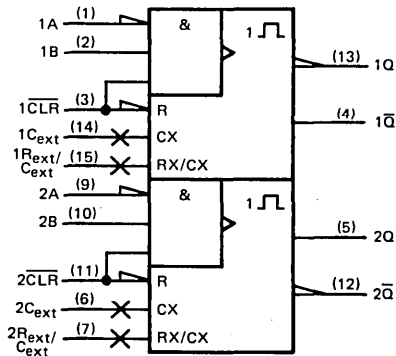

schematics of inputs and outputs

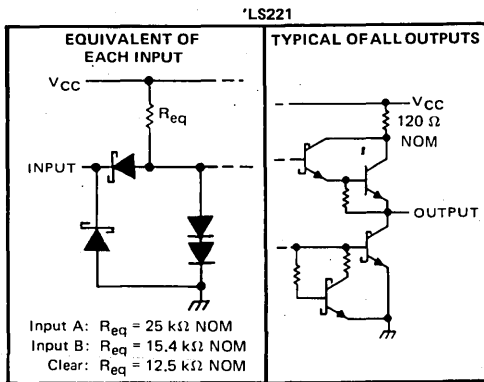
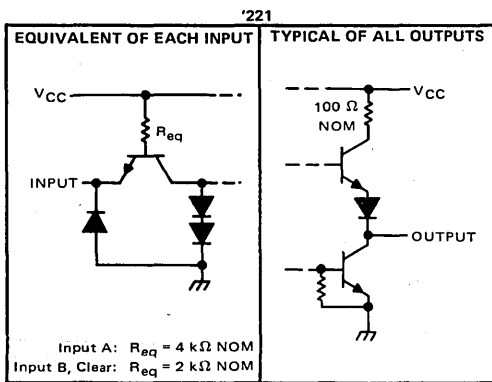

TYPES SN54221, SN74221 DUAL MONOSTABLE MULTIVIBRATORS WITH SCHMITT-TRIGGER INPUTS

recommended operating conditions

		SN54221			SN74221			UNIT
		MIN	NOM	MAX	MIN	NOM	MAX	
Supply voltage, V_{CC}		4.5	5	5.5	4.75	5	5.25	V
High-level output current, I_{OH}					-800			μ A
Low-level output current, I_{OL}					16			mA
Rate of rise or fall of input pulse, dv/dt	Schmitt input, B	1			1			V/s
	Logic input, A	1			1			V/ μ s
Input pulse width	A or B, $t_{W(in)}$	50			50			ns
	Clear, $t_{W(clear)}$	20			20			
Clear-inactive-state setup time, t_{su}		15			15			ns
External timing resistance, R_{ext}		1.4	30		1.4	40		k Ω
External timing capacitance, C_{ext}		0		1000	0		1000	μ F
Output duty cycle	$R_{ext} = 2 \text{ k}\Omega$				67			%
	$R_{ext} = \text{MAX } R_{ext}$				90			
Operating free-air temperature, T_A		-55		125	0		70	$^{\circ}$ C

electrical characteristics over recommended operating free-air temperature range (unless otherwise noted)

PARAMETER		TEST CONDITIONS [†]		MIN	TYP [‡]	MAX	UNIT	
V_{T+}	Positive-going threshold voltage at A input	$V_{CC} = \text{MIN}$			1.4	2	V	
V_{T-}	Negative-going threshold voltage at A input	$V_{CC} = \text{MIN}$		0.8	1.4		V	
V_{T+}	Positive-going threshold voltage at B input	$V_{CC} = \text{MIN}$			1.55	2	V	
V_{T-}	Negative-going threshold voltage at B input	$V_{CC} = \text{MIN}$		0.8	1.35		V	
V_{IK}	Input clamp voltage	$V_{CC} = \text{MIN}, I_I = -12 \text{ mA}$					-1.5	V
V_{OH}	High-level output voltage	$V_{CC} = \text{MIN}, I_{OH} = -800 \mu\text{A}$		2.4	3.4		V	
V_{OL}	Low-level output voltage	$V_{CC} = \text{MIN}, I_{OL} = 16 \text{ mA}$					0.2	V
I_I	Input current at maximum input voltage	$V_{CC} = \text{MAX}, V_I = 5.5 \text{ V}$					1	mA
I_{IH}	High-level input current	$V_{CC} = \text{MAX}, V_I = 2.4 \text{ V}$		Input A		40	μ A	
				Input B, Clear		80		
I_{IL}	Low-level input current	$V_{CC} = \text{MAX}, V_I = 0.4 \text{ V}$		Input A		-1.6	mA	
				Input B, Clear		-3.2		
I_{OS}	Short-circuit output current [§]	$V_{CC} = \text{MAX}$		SN54221		-20	mA	
				SN74221		-18		
I_{CC}	Supply current	$V_{CC} = \text{MAX}$		Quiescent		26	mA	
				Triggered		46		

[†]For conditions shown as MIN or MAX, use the appropriate value specified under recommended operating conditions.

[‡]All typical values are at $V_{CC} = 5 \text{ V}, T_A = 25^{\circ}\text{C}$.

[§]Not more than one output should be shorted at a time.

switching characteristics, $V_{CC} = 5 \text{ V}, T_A = 25^{\circ}\text{C}$

PARAMETER [¶]	FROM (INPUT)	TO (OUTPUT)	TEST CONDITIONS		MIN	TYP	MAX	UNIT
t_{PLH}	A	Q	$C_L = 15 \text{ pF}, R_L = 400 \Omega,$ See Figure 1 and Note 2	$C_{ext} = 80 \text{ pF}, R_{ext} = 2 \text{ k}\Omega$	45	70	ns	
	B	Q						
t_{PHL}	A	\bar{Q}			50	80	ns	
	B	\bar{Q}						
t_{PHL}	Clear	Q			27	ns		
t_{PLH}	Clear	\bar{Q}			40	ns		
$t_{w(out)}$	A or B	Q or \bar{Q}	$C_{ext} = 80 \text{ pF}, R_{ext} = 2 \text{ k}\Omega$	70	110	150	ns	
			$C_{ext} = 0, R_{ext} = 2 \text{ k}\Omega$	20	30	50		
			$C_{ext} = 100 \text{ pF}, R_{ext} = 10 \text{ k}\Omega$	650	700	750		
			$C_{ext} = 1 \mu\text{F}, R_{ext} = 10 \text{ k}\Omega$	6.5	7	7.5		ms

[¶] t_{PLH} \equiv Propagation delay time, low-to-high-level output

t_{PHL} \equiv Propagation delay time, high-to-low-level output

$t_{w(out)}$ \equiv Output pulse width

NOTE 2: See General Information Section for load circuits and voltage waveforms.

TYPES SN54LS221, SN74LS221 DUAL MONOSTABLE MULTIVIBRATORS WITH SCHMITT-TRIGGER INPUTS

recommended operating conditions

	SN54LS221			SN74LS221			UNIT
	MIN	NOM	MAX	MIN	NOM	MAX	
Supply voltage, V_{CC}	4.5	5	5.5	4.75	5	5.25	V
High-level output current, I_{OH}	-400			-400			μ A
Low-level output current, I_{OL}	4			8			mA
Rate of rise or fall of input pulse, dv/dt	Schmitt, B	1		1			V/s
	Logic input, A	1		1			V/ μ s
Input pulse width	A or B, $t_w(\text{in})$	50		50			ns
	Clear, $t_w(\text{clear})$	40		40			
Clear-inactive-state setup time, t_{su}	15		15			ns	
External timing resistance, R_{ext}	1.4		70	1.4		100	k Ω
External timing capacitance, C_{ext}	0		1000	0		1000	μ F
Output duty cycle	$R_T = 2 \text{ k}\Omega$		50		50		%
	$R_T = \text{MAX } R_{ext}$		90		90		
Operating free-air temperature, T_A	-55		125	0		70	$^{\circ}$ C

electrical characteristics over recommended operating free-air temperature range (unless otherwise noted)

PARAMETER	TEST CONDITIONS [†]	SN54LS221			SN74LS221			UNIT
		MIN	TYP [‡]	MAX	MIN	TYP [‡]	MAX	
V_{T+} Positive-going threshold voltage at A input	$V_{CC} = \text{MIN}$	1.0		2	1.0		2	V
V_{T-} Negative-going threshold voltage at A input	$V_{CC} = \text{MIN}$	0.7	1.0		0.8	1.0		V
V_{T+} Positive-going threshold voltage at B input	$V_{CC} = \text{MIN}$	1.0		2	1.0		2	V
V_{T-} Negative-going threshold voltage at B input	$V_{CC} = \text{MIN}$	0.7	0.9		0.8	0.9		V
V_{IK} Input clamp voltage	$V_{CC} = \text{MIN}$, $I_I = -18 \text{ mA}$	-1.5			-1.5			V
V_{OH} High-level output voltage	$V_{CC} = \text{MIN}$, $I_{OH} = -400 \mu\text{A}$	2.5	3.4		2.7	3.4		V
V_{OL} Low-level output voltage	$V_{CC} = \text{MIN}$	$I_{OL} = 4 \text{ mA}$		0.25	0.4		0.25	V
		$I_{OL} = 8 \text{ mA}$		0.35		0.5		
I_I Input current at maximum input voltage	$V_{CC} = \text{MAX}$, $V_I = 7 \text{ V}$	0.1			0.1			mA
I_{IH} High-level input current	$V_{CC} = \text{MAX}$, $V_I = 2.7 \text{ V}$	20			20			μ A
I_{IL} Low-level input current	Input A	-0.4			-0.4			mA
	Input B	-0.8			-0.8			
	Clear	-0.8			-0.8			
I_{OS} Short-circuit output current [§]	$V_{CC} = \text{MAX}$	-20	-100		-20	-100		mA
I_{CC} Supply current	$V_{CC} = \text{MAX}$	Quiescent		4.7	11		4.7	mA
		Triggered		19	27		19	

[†] For conditions shown as MIN or MAX, use the appropriate value specified under recommended operating conditions.

[‡] All typical values are at $V_{CC} = 5 \text{ V}$, $T_A = 25^{\circ}\text{C}$

[§] Not more than one output should be shorted at a time and duration of the short-circuit should not exceed one second.

3
TTL DEVICES

TYPES SN54221, SN54LS221, SN74221, SN74LS221
 DUAL MONOSTABLE MULTIVIBRATORS
 WITH SCHMITT-TRIGGER INPUTS

switching characteristics, $V_{CC} = 5\text{ V}$, $T_A = 25^\circ\text{C}$

PARAMETER [†]	FROM (INPUT)	TO (OUTPUT)	TEST CONDITIONS		MIN	TYP	MAX	UNIT
t_{PLH}	A	Q	$C_L = 15\text{ pF}$, $R_L = 2\text{ k}\Omega$, See Figure 1 and Note 3	$C_{ext} = 80\text{ pF}$, $R_{ext} = 2\text{ k}\Omega$	45	70	ns	
	B	Q			35	55		
t_{PHL}	A	\bar{Q}			50	80	ns	
	B	\bar{Q}			40	65		
t_{PHL}	Clear	Q			35	55	ns	
t_{PLH}	Clear	\bar{Q}			44	65	ns	
$t_{w(out)}$	A or B	Q or \bar{Q}		$C_{ext} = 80\text{ pF}$, $R_{ext} = 2\text{ k}\Omega$	70	120	150	ms
				$C_{ext} = 0$, $R_{ext} = 2\text{ k}\Omega$	20	47	70	
				$C_{ext} = 100\text{ pF}$, $R_{ext} = 10\text{ k}\Omega$	670	740	810	
				$C_{ext} = 1\text{ }\mu\text{F}$, $R_{ext} = 10\text{ k}\Omega$	6	6.9	7.5	

[†] t_{PLH} \equiv Propagation delay time, low-to-high-level output

t_{PHL} \equiv Propagation delay time, high-to-low-level output

$t_{w(out)}$ \equiv Output pulse width

NOTE 3: See General Information Section for load circuits and voltage waveforms.

TYPES SN54221, SN54LS221, SN74221, SN74LS221
DUAL MONOSTABLE MULTIVIBRATORS
WITH SCHMITT-TRIGGER INPUTS

PARAMETER MEASUREMENT INFORMATION

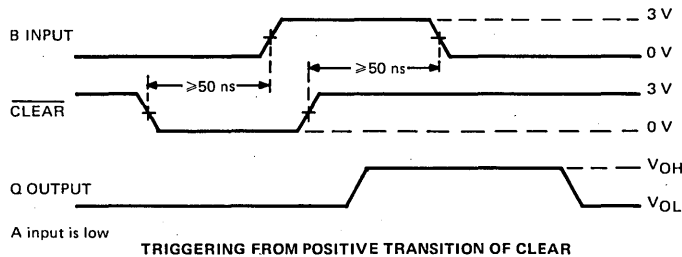
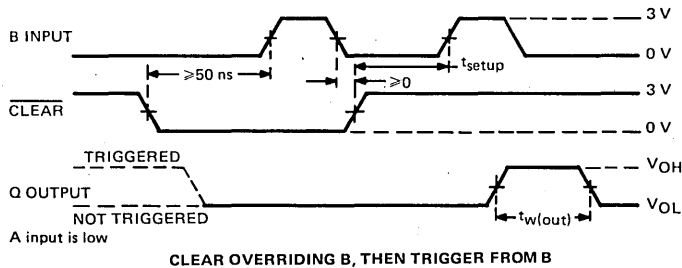
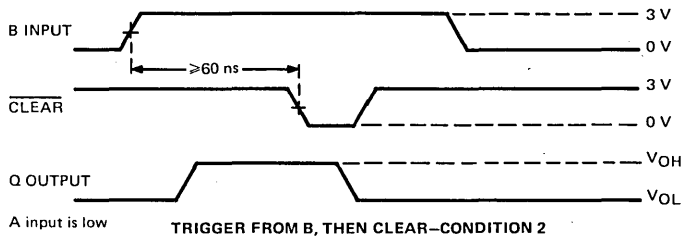
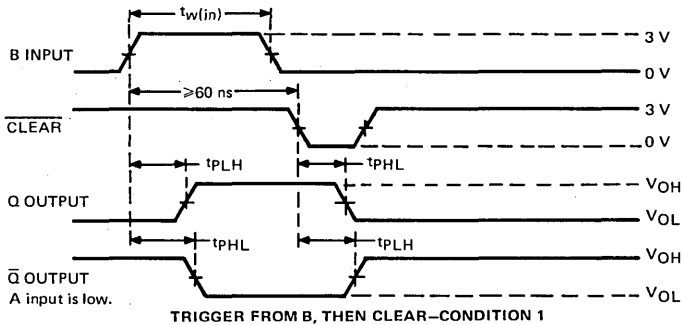

FIGURE 1—SWITCHING CHARACTERISTICS

3

TTL DEVICES

TYPES SN54221, SN54LS221, SN74221, SN74LS221
 DUAL MONOSTABLE MULTIVIBRATORS
 WITH SCHMITT-TRIGGER INPUTS

PARAMETER MEASUREMENT INFORMATION

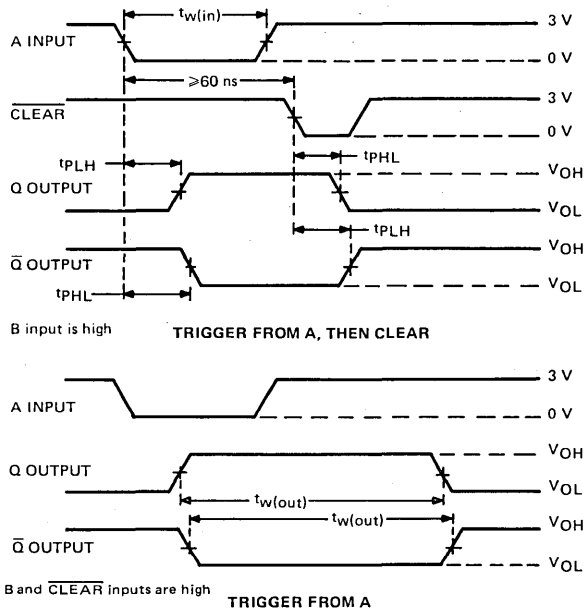

- NOTES: A. Input pulses are supplied by generators having the following characteristics: PRR \leq 1 MHz, $Z_{out} \approx 50 \Omega$; for '221, $t_r \leq 7$ ns, $t_f \leq 7$ ns, for 'LS221, $t_r \leq 15$ ns, $t_f \leq 6$ ns.
 B. All measurements are made between the 1.5 V points of the indicated transitions for the '221 or between the 1.3 V points for the 'LS221.

FIGURE 1—SWITCHING CHARACTERISTICS (CONTINUED)

TYPES SN54221, SN74221 DUAL MONOSTABLE MULTIVIBRATORS WITH SCHMITT-TRIGGER INPUTS

TYPICAL CHARACTERISTICS ('221 ONLY)†

DISTRIBUTION OF UNITS
for
OUTPUT PULSE WIDTH

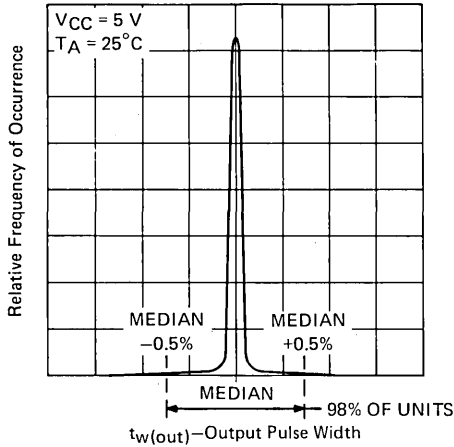

FIGURE 2

VARIATION IN OUTPUT PULSE WIDTH
vs
SUPPLY VOLTAGE

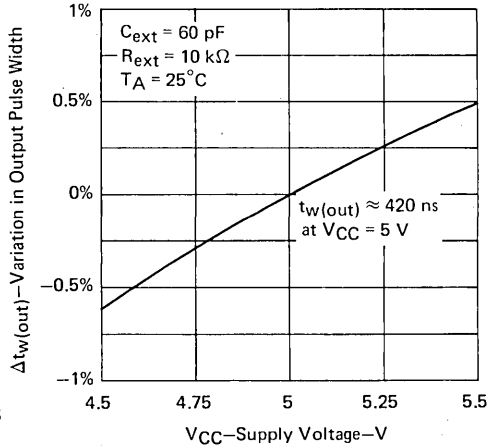

FIGURE 3

VARIATION IN OUTPUT PULSE WIDTH
vs
FREE-AIR TEMPERATURE

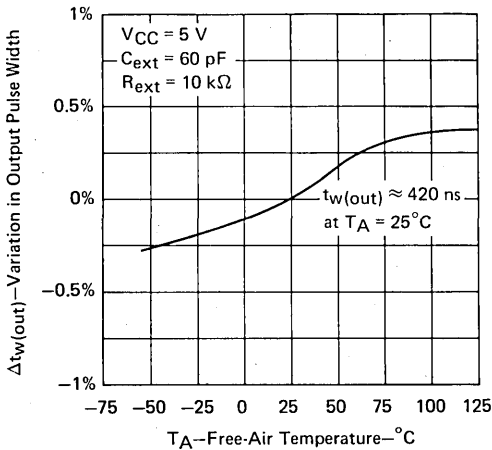

FIGURE 4

OUTPUT PULSE WIDTH
vs
TIMING RESISTOR VALUE

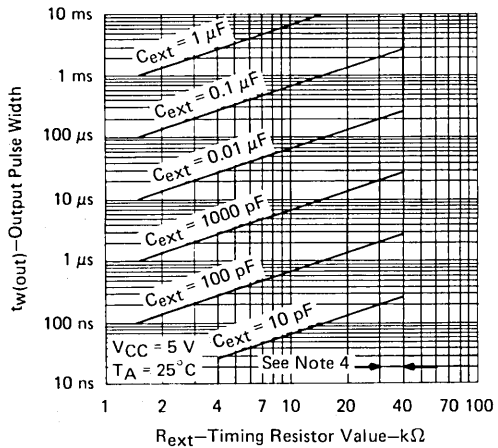

FIGURE 5

NOTE 4: These values of resistance exceed the maximum recommended for use over the full temperature range of the SN54221.

†Data for temperatures below 0°C and above 70°C, and for supply voltages below 4.75 V and above 5.25 V are applicable for the SN54221 only.

3

TTL DEVICES

TYPES SN54S226, SN74S226 4-BIT PARALLEL LATCHED BUS TRANCEIVERS

OCTOBER 1976—REVISED DECEMBER 1983

- Universal Transceivers for Implementing System Bus Controllers
- Dual-Rank 4-Bit Transparent Latches Provide:
 - Exchange of Data Between 2 Buses In One Clock Pulse
 - Bus-to-Bus Isolation
 - Rapid Data Transfer
 - Full Storage Capability
- Hysteresis at Data Inputs Enhances Noise Rejection
- Separate Output-Control Inputs Provide Independent Enable/Disable for Either Bus Output
- 3-State Outputs Drive Bus Lines Directly

description

These high-performance Schottky TTL quadruple bus transceivers employ dual-rank bidirectional four-bit transparent latches and feature three-state outputs designed specifically for driving highly-capacitive or relatively low-impedance loads. The bus-management functions implemented and the high-impedance controls offered provide the designer with a controller/transceiver that interfaces and drives system bus-organized lines directly. They are particularly attractive for implementing:

- Bidirectional bus transceivers
- Data-bus controllers

The bus-management functions, under control of the function-select (S1, S2) inputs, provide complete data integrity for each of the four modes described in the function table. Directional transparency provides for routing data from or to either bus, and the dual store and dual readout capabilities can be used to perform the exchange of data between the two bus lines in the equivalent of a single clock pulse. Storage of data is accomplished by selecting the latch function, setting up the data, and taking the appropriate strobe input low. As long as the strobe is held high, the data is latched for the selected function. Further control is offered through the availability of independent output controls that can be used to enable or disable the outputs as shown in the output-control function table, regardless of the latch function in process. Store operations can be performed with the outputs disabled to a high impedance (Hi-Z). In the Hi-Z state the inputs/outputs neither load nor drive the bus lines significantly. The p-n-p inputs feature typically 400 millivolts of hysteresis to enhance noise rejection.

BUS-MANAGEMENT FUNCTION TABLE

MODE CONTROLS		STROBES		A-TO-B LATCHES		B-TO-A LATCHES		OPERATION
S2	S1	GAB	GBA	1	2	1	2	
L	L	X	L	Latch	Trans	Trans	Trans	Pass B to A Read out stored data
L	H	X	X	Latch	Trans	Latch	Trans	Read out stored data
H	L	L	X	Trans	Trans	Latch	Trans	Pass A to B Read out stored data
H	H	L	L	Trans	Latch	Trans	Latch	Read in both buses Store bus data

H = high level L = low level X = irrelevant Latch = latched Trans = transparent

SN54S226 . . . J OR W PACKAGE
SN74S226 . . . D, J OR N PACKAGE

(TOP VIEW)

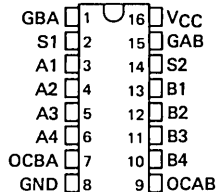

SN54S226 . . . FK PACKAGE
SN74S226 . . . FN PACKAGE

(TOP VIEW)

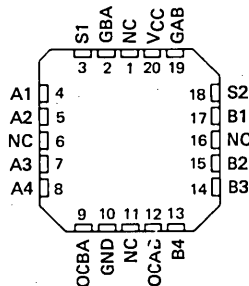

NC - No internal connection

PRODUCTION DATA
This document contains information current as of publication date. Products conform to specifications per the terms of Texas Instruments standard warranty. Production processing does not necessarily include testing of all parameters.

**TEXAS
INSTRUMENTS**

POST OFFICE BOX 225012 • DALLAS, TEXAS 75265

TYPES SN54S226, SN74S226 4-BIT PARALLEL LATCHED BUS TRANCEIVERS

logic symbol†

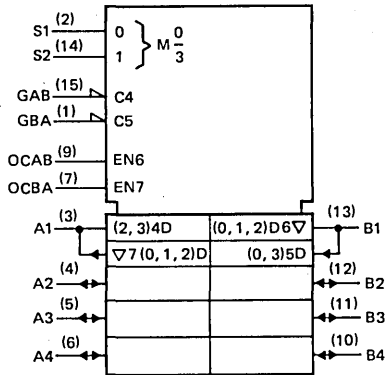

† This symbol is in accordance with IEEE Std 91/ANSI Y32.14 and current discussions in IEC and IEEE.

logic diagram (positive logic)

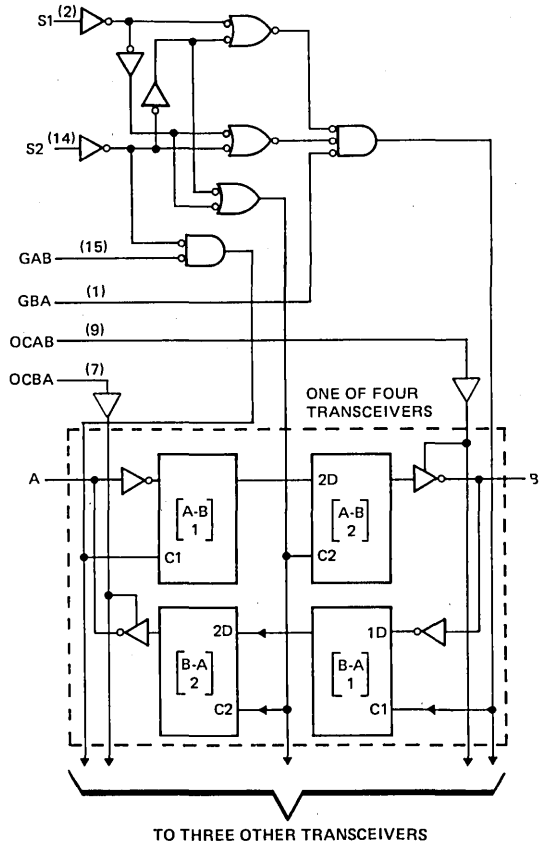

Pin numbers shown on logic notation are for D, J or N packages.

absolute maximum ratings over operating free-air temperature range (unless otherwise noted)

Supply voltage, V_{CC} (see Note 1)	7 V
Input voltage	5.5 V
Off-state output voltage	5.5 V
Operating free-air temperature range: SN54S226 (see Note 2)	-55°C to 125°C
SN74S226	0°C to 70°C
Storage temperature range	-65°C to 150°C

- NOTES: 1. Voltage values are with respect to network ground terminal.
 2. An SN54S226 in the J package operating at temperatures above 113°C requires a heat-sink that provides a thermal resistance from case to free air, $R_{\theta CA}$, of not more than 48°C/W.

TYPES SN54S226, SN74S226

4-BIT PARALLEL LATCHED BUS TRANSCEIVERS

recommended operating conditions

	SN54S226			SN74S226			UNIT
	MIN	NOM	MAX	MIN	NOM	MAX	
Supply voltage, V_{CC}	4.5	5	5.5	4.75	5	5.25	V
High-level output voltage, V_{OH}				5.5			V
High-level output current, I_{OH}				-6.5			mA
Width of strobe pulse	30			20			ns
Setup time, t_{su}	To Strobe		30†	To Select		20†	ns
	To Select		30	To Strobe		20	ns
Hold time, t_h	To Strobe		0†	To Select		0	ns
	To Select		0	To Strobe		0	ns
Operating free-air temperature, T_A (see Note 2)	-55			125			°C

† The arrow indicates that the low-to-high transition of the strobe input is used for reference.

electrical characteristics over recommended operating free-air temperature range (unless otherwise noted)

PARAMETER		TEST CONDITIONS†	MIN	TYP‡	MAX	UNIT	
V_{IH}	High-level input voltage		2			V	
V_{IL}	Low-level input voltage				0.8	V	
V_{IK}	Input clamp voltage				-1.2	V	
V_{OH}	High-level output voltage	SN54S226	$V_{CC} = \text{MIN}, I_I = -18 \text{ mA}$			V	
		SN74S226	$V_{CC} = \text{MIN}, V_{IH} = 2 \text{ V},$ $V_{IL} = 0.8 \text{ V}, I_{OH} = \text{MAX}$	2.4	3.3	V	
V_{OL}	Low-level output voltage	$V_{CC} = \text{MIN}, V_{IH} = 2 \text{ V},$ $V_{IL} = 0.8 \text{ V}, I_{OL} = 15 \text{ mA}$			0.5	V	
I_{OZH}	Off-state output current, high-level voltage applied	$V_{CC} = \text{MAX}, V_{IH} = 2 \text{ V},$ $V_O = 2.4 \text{ V}$			100	μA	
I_{OZL}	Off-state output current, low-level voltage applied	$V_{CC} = \text{MAX}, V_{IH} = 2 \text{ V},$ $V_O = 0.5 \text{ V}$			-250	μA	
I_I	Input current at maximum input voltage	$V_{CC} = \text{MAX}, V_I = 5.5 \text{ V}$			1	mA	
I_{IH}	High-level input current	$V_{CC} = \text{MAX}, V_I = 2.7 \text{ V}$			100	μA	
I_{IL}	Low-level input current	GAB, GBA	$V_{CC} = \text{MAX}, V_I = 0.5 \text{ V}$		-0.38	mA	
		All other inputs			-1.6	mA	
I_{OS}	Short-circuit output current §	$V_{CC} = \text{MAX}$			-50	mA	
I_{CC}	Supply current	$V_{CC} = \text{MAX},$ See Note 3			125	185	mA

† For conditions shown as MIN or MAX, use the appropriate value specified under recommended operating conditions.

‡ All typical values are at $V_{CC} = 5 \text{ V}, T_A = 25^\circ \text{C}$.

§ Not more than one output should be shorted at a time and duration of the short-circuit should not exceed one second.

NOTES: 2. An SN54S226 in the J package operating at temperatures above 113°C requires a heat-sink that provides a thermal resistance from case to free air, $R_{\theta CA}$, of not more than 48°C/W .

3. I_{CC} is measured with all inputs (and outputs) grounded.

3

TTL DEVICES

TYPES SN54S226, SN74S226

4-BIT PARALLEL LATCHED BUS TRANSCEIVERS

switching characteristics, $V_{CC} = 5\text{ V}$, $T_A = 25^\circ\text{C}$

PARAMETER	FROM (INPUT)	TO (OUTPUT)	TEST CONDITIONS	MIN	TYP	MAX	UNIT
t_{PLH}	A or B	B or A	$C_L = 50\text{ pF}$, See Note 4	$R_L = 280\ \Omega$,	20	30	ns
t_{PHL}					15	30	
t_{PLH}					25	37	
t_{PHL}	Select	Any			19	30	ns
t_{PLH}					25	37	
t_{PHL}	Strobe GBA or GAB	A or B			19	30	ns
t_{PLH}			25	37			
t_{PZH}	Output Control OCBA or OCAB	A or B	12	20	ns		
t_{PZL}			12	20			
t_{PHZ}	Output Control OCBA or OCAB	A or B	$C_L = 5\text{ pF}$,	$R_L = 280\ \Omega$,	10	15	ns
t_{PLZ}			See Note 4		10	15	

t_{PLH} = propagation delay time, low-to-high-level output

t_{PHL} = propagation delay time, high-to-low level

t_{PZH} = output enable time to high level

t_{PZL} = output enable time to low level

t_{PHZ} = output disable time from high level

t_{PLZ} = output disable time from low level

NOTE 4: See General Information Section for load circuits and voltage waveforms.

applications

The following examples demonstrate four fundamental bus-management functions that can be performed with the 'S226. Exchange of data on the two bus lines can be accomplished with a single high-to-low transition at S2 when S1 is high.

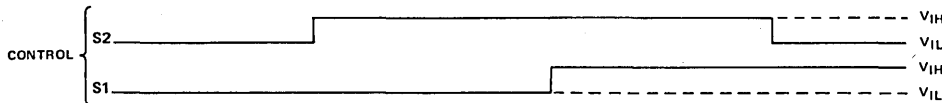
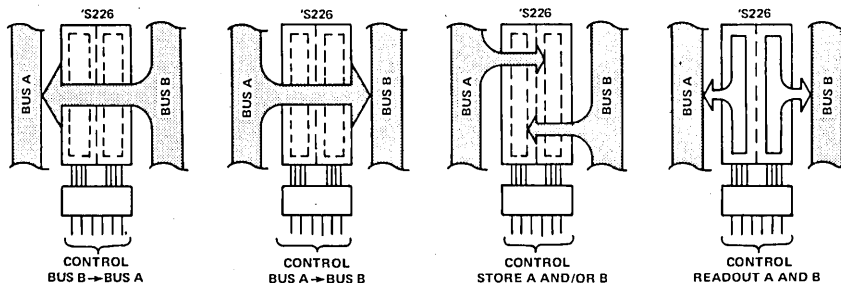

TYPES SN54LS240, SN54LS241, SN54LS244, SN54S240, SN54S241, SN54S244, SN74LS240, SN74LS241, SN74LS244, SN74S240, SN74S241, SN74S244

OCTAL BUFFERS AND LINE DRIVERS WITH 3-STATE OUTPUTS

REVISED APRIL 1985

- 3-State Outputs Drive Bus Lines or Buffer Memory Address Registers
- PNP Inputs Reduce D-C Loading
- Hysteresis at Inputs Improves Noise Margins

description

These octal buffers and line drivers are designed specifically to improve both the performance and density of three-state memory address drivers, clock drivers, and bus-oriented receivers and transmitters. The designer has a choice of selected combinations of inverting and noninverting outputs, symmetrical \bar{G} (active-low output control) inputs, and complementary \bar{G} and \bar{G} inputs. These devices feature high fan-out, improved fan-in, and 400-mV noise-margin. The SN74LS' and SN74S' can be used to drive terminated lines down to 133 ohms.

The SN54' family is characterized for operation over the full military temperature range of -55°C to 125°C . The SN74' family is characterized for operation from 0°C to 70°C .

SN54LS', SN54S' ... J PACKAGE
SN74LS', SN74S' ... DW, J OR N PACKAGE
(TOP VIEW)

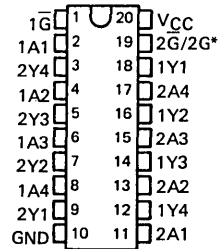

SN54LS', SN54S' ... FK PACKAGE
SN74LS', SN74S' ... FN PACKAGE
(TOP VIEW)

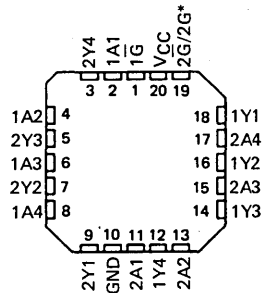

*2G for 'LS241 and 'S241 or 2G for all other drivers.

schematics of inputs and outputs

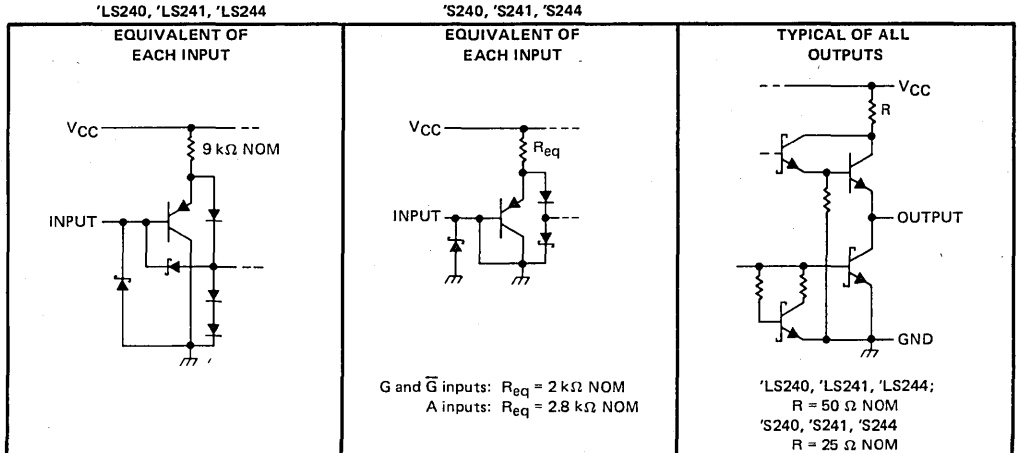

PRODUCTION DATA
This document contains information current as of publication date. Products conform to specifications per the terms of Texas Instruments standard warranty. Production processing does not necessarily include testing of all parameters.

TEXAS INSTRUMENTS

POST OFFICE BOX 225012 • DALLAS, TEXAS 75265

3

TTL DEVICES

TYPES SN54LS240, SN54LS241, SN54LS244, SN54S240, SN54S241, SN54S244, SN74LS240, SN74LS241, SN74LS244, SN74S240, SN74S241, SN74S244 OCTAL BUFFERS AND LINE DRIVERS WITH 3-STATE OUTPUTS

logic symbols

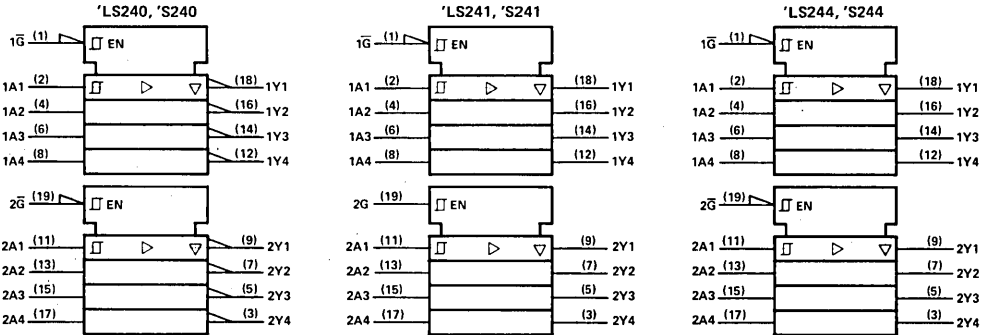

logic diagrams (positive logic)

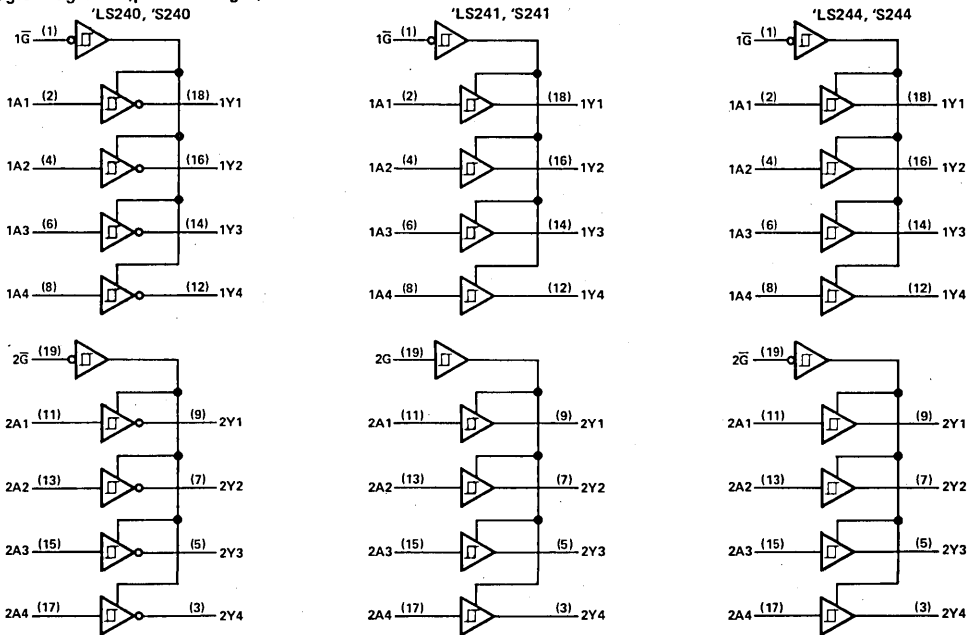

Pin numbers shown on logic notation are for DW, J or N packages.

absolute maximum ratings over operating free-air temperature range (unless otherwise noted)

Supply voltage, V_{CC} (see Note 1)	7 V
Input voltage: 'LS Circuits	7 V
'S Circuits	5.5 V
Off-state output voltage	5.5 V
Operating free-air temperature range: SN54LS', SN54S' Circuits	-55° C to 125° C
SN74LS', SN74S' Circuits	0° C to 70° C
Storage temperature range	-65° C to 150° C

NOTE 1: Voltage values are with respect to network ground terminal.

TYPES SN54LS240, SN54LS241, SN54LS244, SN74LS240, SN74LS241, SN74LS244 OCTAL BUFFERS AND LINE DRIVERS WITH 3-STATE OUTPUTS

recommended operating conditions

PARAMETER	SN54LS'			SN74LS'			UNIT
	MIN	NOM	MAX	MIN	NOM	MAX	
V _{CC} Supply voltage (see Note 1)	4.5	5	5.5	4.75	5	5.25	V
V _{IH} High-level input voltage	2			2			V
V _{IL} Low-level input voltage			0.7			0.8	V
I _{OH} High-level output current			-12			-15	mA
I _{OL} Low-level output current			12			24	mA
T _A Operating free-air temperature	-55		125	0		70	°C

NOTE 1: Voltage values are with respect to network ground terminal.

electrical characteristics over recommended operating free-air temperature range (unless otherwise noted)

PARAMETER	TEST CONDITIONS†		SN54LS'			SN74LS'			UNIT
			MIN	TYP‡	MAX	MIN	TYP‡	MAX	
V _{IK}	V _{CC} = MIN, I _I = -18 mA		-1.5			-1.5			V
Hysteresis (V _{T+} - V _{T-})	V _{CC} = MIN		0.2	0.4		0.2	0.4		V
V _{OH}	V _{CC} = MIN, V _{IH} = 2 V, V _{IL} = MAX, I _{OH} = -3 mA		2.4	3.4		2.4	3.4		V
	V _{CC} = MIN, V _{IH} = 2 V, V _{IL} = 0.5 V, I _{OH} = MAX		2			2			
V _{OL}	V _{CC} = MIN, V _{IH} = 2 V, V _{IL} = MAX		0.4			0.4			V
	V _{CC} = MAX, V _{IH} = 2 V, V _O = 2.7 V		20			20			
I _{OZH}	V _{CC} = MAX, V _{IH} = 2 V, V _{IL} = MAX		-20			-20			μA
I _{OZL}	V _{CC} = MAX, V _I = 7 V		0.1			0.1			mA
I _{IH}	V _{CC} = MAX, V _I = 2.7 V		20			20			μA
I _{IL}	V _{CC} = MAX, V _{IL} = 0.4 V		-2.0			-2.0			mA
I _{OS} §	V _{CC} = MAX		-40		-225	-40		-225	mA
I _{CC}	Outputs high	V _{CC} = MAX, Output open	All	17	27	17	27	mA	
	Outputs low		'LS240	26	44	26	44		
	All outputs disabled		'LS241, 'LS244	27	46	27	46		
			'LS240	29	50	29	50		
		'LS241, 'LS244	32	54	32	54			

† For conditions shown as MIN or MAX, use the appropriate value specified under recommended operating conditions.

‡ All typical values are at V_{CC} = 5 V, T_A = 25°C.

§ Not more than one output should be shorted at a time, and duration of the short-circuit should not exceed one second.

switching characteristics, V_{CC} = 5 V, T_A = 25°C

PARAMETER	TEST CONDITIONS		'LS240			'LS241, 'LS244			UNIT
			MIN	TYP	MAX	MIN	TYP	MAX	
t _{PLH}	R _L = 667 Ω, See Note 2	C _L = 45 pF,	9	14		12	18		ns
t _{PHL}			12	18		12	18		ns
t _{PZL}			20	30		20	30		ns
t _{PZH}			15	23		15	23		ns
t _{PLZ}			R _L = 667 Ω, See Note 2	C _L = 5 pF,	10	20		10	20
t _{PHZ}	15	25				15	25		ns

NOTE 2: See General Information Section for load circuits and voltage waveforms.



TTL DEVICES

TYPES SN54S240, SN54S241, SN54S244, SN74S240, SN74S241, SN74S244 OCTAL BUFFERS AND LINE DRIVERS WITH 3-STATE OUTPUTS

recommended operating conditions

PARAMETER	SN54S'			SN74S'			UNIT	
	MIN	NOM	MAX	MIN	NOM	MAX		
V _{CC} Supply voltage, (see Note 1)	4.5	5	5.5	4.75	5	5.25	V	
V _{IH} High-level input voltage	2			2			V	
V _{IL} Low-level input voltage	0.8			0.8			V	
I _{OH} High-level output current	-12			-15			mA	
I _{OL} Low-level output current	48			64			mA	
External resistance between any input and V _{CC} or ground	40			40			kΩ	
T _A Operating free-air temperature (see Note 3)	-55			0			70	°C

NOTES: 1. Voltage values are with respect to network ground terminal.

3. An SN54S241J operating at free-air temperature above 116°C requires a heat sink that provides a thermal resistance from case to free-air R_{θCA}, of not more than 40°C/W.

electrical characteristics over recommended operating free-air temperature range (unless otherwise noted)

PARAMETER	TEST CONDITIONS†	SN54S'		SN74S'		UNIT		
		MIN	TYP‡ MAX	MIN	TYP‡ MAX			
V _{IK}	V _{CC} = MIN, I _I = -18 mA	-1.2		-1.2		V		
Hysteresis (V _{T+} - V _{T-})	V _{CC} = MIN	0.2	0.4	0.2	0.4	V		
V _{OH}	V _{CC} = MIN, V _{IH} = 2 V, V _{IL} = 0.8 V, I _{OH} = -1 mA	2.7		2.7		V		
	V _{CC} = MIN, V _{IH} = 2 V, V _{IL} = 0.8 V, I _{OH} = -3 mA	2.4	3.4	2.4	3.4			
	V _{CC} = MIN, V _{IH} = 2 V, V _{IL} = 0.5 V, I _{OH} = MAX	2		2				
V _{OL}	V _{CC} = MIN, V _{IH} = 2 V, V _{IL} = 0.8 V, I _{OL} = MAX	0.55		0.55		V		
I _{OZH}	V _{CC} = MAX, V _{IH} = 2 V, V _O = 2.4 V	50		50		μA		
I _{OZL}	V _{IL} = 0.8 V, V _O = 0.5 V	-50		-50				
I _I	V _{CC} = MAX, V _I = 5.5 V	1		1		mA		
I _{IH}	V _{CC} = MAX, V _I = 2.7 V	50		50		μA		
I _{IL}	Any A	-400		-400		μA		
	Any G	-2		-2		mA		
I _{OS} §	V _{CC} = MAX	-50	-225	-50	-225	mA		
I _{CC}	V _{CC} = MAX, Outputs open.	Outputs high	'S240	80	123	80	135	mA
			'S241, 'S244	95	147	95	160	
		Outputs low	'S240	100	145	100	150	
			'S241, 'S244	120	170	120	180	
		Outputs disabled	'S240	100	145	100	150	
	'S241, 'S244	120	170	120	180			

† For conditions shown as MIN or MAX, use the appropriate value specified under recommended operating conditions.

‡ All typical values are at V_{CC} = 5 V, T_A = 25°C.

§ Not more than one output should be shorted at a time, and duration of the short-circuit should not exceed one second.

**TYPES SN54S240, SN54S241, SN54S244, SN74S240, SN74S241, SN74S244
OCTAL BUFFERS AND LINE DRIVERS WITH 3-STATE OUTPUTS**

switching characteristics, $V_{CC} = 5\text{ V}$, $T_A = 25^\circ\text{C}$

PARAMETER	TEST CONDITIONS	'S240			'S241, 'S244			UNIT
		MIN	TYP	MAX	MIN	TYP	MAX	
t_{PLH}	$R_L = 90\ \Omega$, See Note 4	$C_L = 50\ \text{pF}$	4.5	7	6	9	ns	
t_{PHL}			4.5	7	6	9	ns	
t_{PZL}			10	15	10	15	ns	
t_{PZH}	$R_L = 90\ \Omega$, See Note 4	$C_L = 5\ \text{pF}$	6.5	10	8	12	ns	
t_{PLZ}			10	15	10	15	ns	
t_{PHZ}			6	9	6	9	ns	

NOTE 4: See General Information Section for load circuits and voltage waveforms.

**TYPES SN54LS240, SN54LS241, SN54LS244, SN54S240, SN54S241, SN54S244
SN74LS240, SN74LS241, SN74LS244, SN74S240, SN74S241, SN74S244
OCTAL BUFFERS AND LINE DRIVERS WITH 3-STATE OUTPUTS**

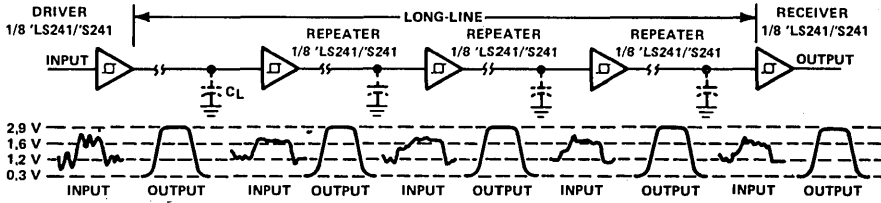

'LS241, 'S241 USED AS REPEATER/LEVEL RESTORER

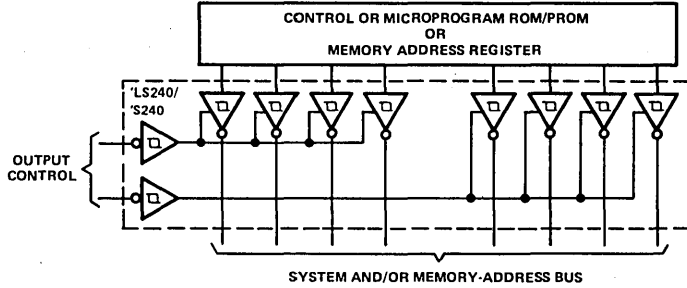

'LS240/'S240 USED AS SYSTEM AND/OR MEMORY BUS DRIVER—4-BIT ORGANIZATION CAN BE APPLIED TO HANDLE BINARY OR BCD

3

TTL DEVICES

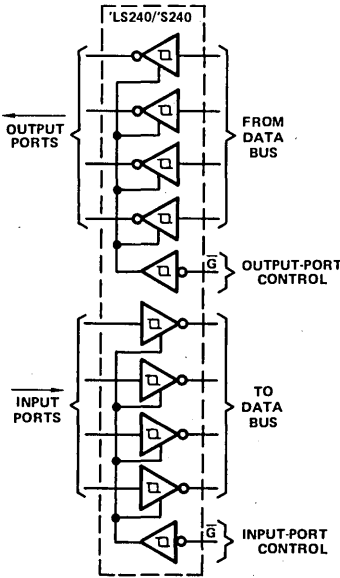

INDEPENDENT 4-BIT BUS DRIVERS/RECEIVERS IN A SINGLE PACKAGE

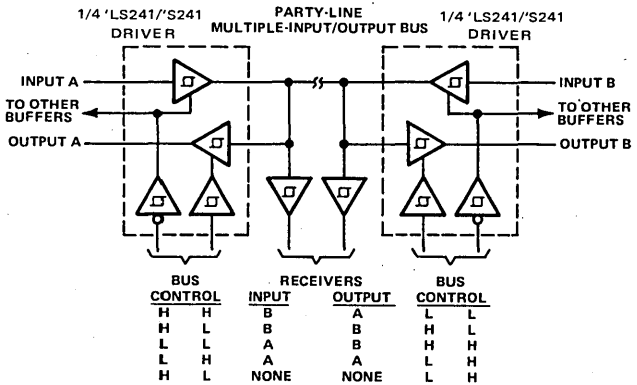

PARTY-LINE BUS SYSTEM WITH MULTIPLE INPUTS, OUTPUTS, AND RECEIVERS

TYPES SN54LS242, SN54LS243, SN74LS242, SN74LS243 QUADRUPLE BUS TRANSCEIVERS

REVISED APRIL 1985

- Two-Way Asynchronous Communication Between Data Buses
- PNP Inputs Reduce D-C Loading
- Hysteresis (Typically 400 mV) at Inputs Improves Noise Margin

description

These four-data-line transceivers are designed for asynchronous two-way communications between data buses. The SN74LS' can be used to drive terminated lines down to 133 ohms.

The SN54' family is characterized for operation over the full military temperature range of -55°C to 125°C . The SN74' family is characterized for operation from 0°C to 70°C .

SN54LS242, SN54LS243 ... J OR W PACKAGE
SN74LS242, SN74LS243 ... D, J OR N PACKAGE
(TOP VIEW)

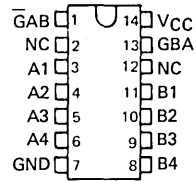

SN54LS242, SN54LS243 ... FK PACKAGE
SN74LS242, SN74LS243 ... FN PACKAGE
(TOP VIEW)

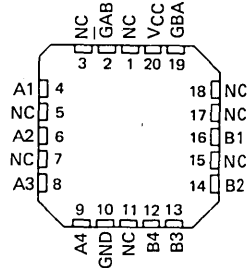

NC-No internal connection

FUNCTION TABLE (EACH TRANSCEIVER)

INPUTS		'LS242	'LS243
GAB	GBA		
L	L	\bar{A} to B	A to B
H	H	\bar{B} to A	B to A
H	L	Isolation	Isolation
L	H	Latch A and B ($A = \bar{B}$)	Latch A and B ($A = B$)

schematics of inputs and outputs

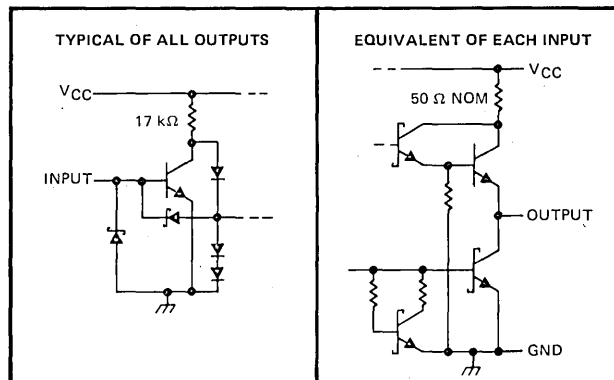

PRODUCTION DATA
This document contains information current as of publication date. Products conform to specifications per the terms of Texas Instruments standard warranty. Production processing does not necessarily include testing of all parameters.

TEXAS
INSTRUMENTS

POST OFFICE BOX 225012 • DALLAS, TEXAS 75265

3-823

3

TTL DEVICES

TYPES SN54LS242, SN54LS243, SN74LS242, SN74LS243 QUADRUPLE BUS TRANSCEIVERS

logic symbols

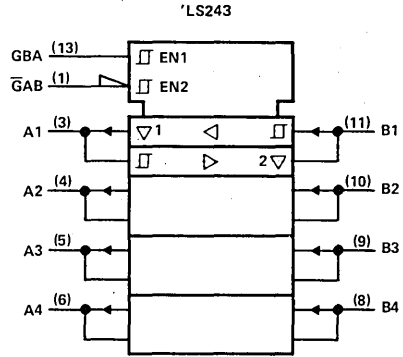
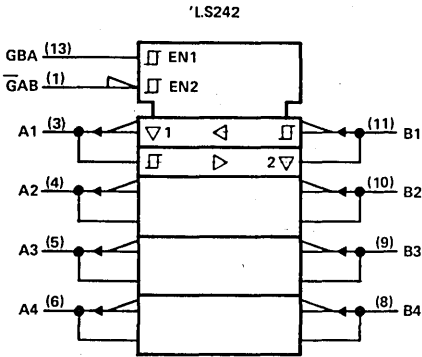

logic diagrams (positive logic)

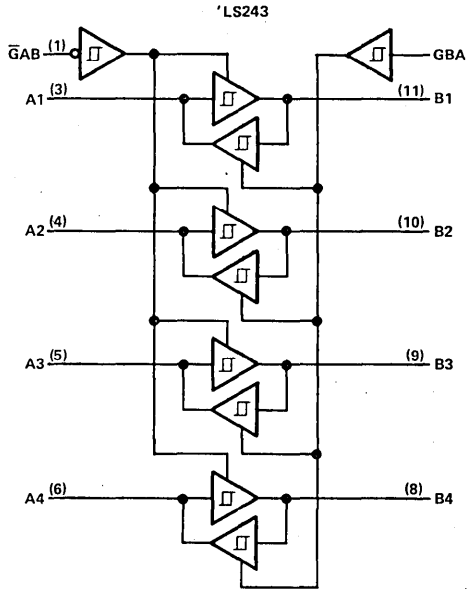
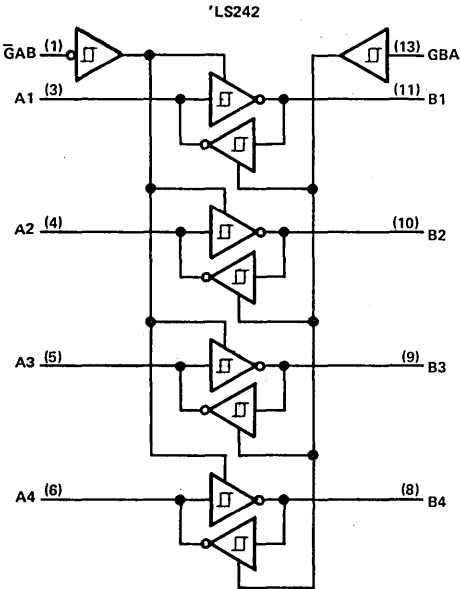

Pin numbers shown on logic notation are for D, J or N packages.

absolute maximum ratings over operating free-air temperature range (unless otherwise noted)

Supply voltage, V_{CC} (see Note 1)	7 V
Input voltage	7 V
Off-state output voltage	5.5 V
Operating free-air temperature range: SN54LS'	-55°C to 125°C
SN74LS'	0°C to 70°C
Storage temperature range	-65°C to 150°C

NOTE 1: Voltage values are with respect to network ground terminal.

TYPES SN54LS242, SN54LS243, SN74LS242, SN74LS243 QUADRUPLE BUS TRANSCEIVERS

recommended operating conditions

	SN54LS'			SN74LS'			UNIT
	MIN	NOM	MAX	MIN	NOM	MAX	
V _{CC} Supply voltage, (see Note 1)	4.5	5	5.5	4.75	5	5.25	V
V _{IH} High-level input voltage	2			2			V
V _{IL} Low-level input voltage			0.7			0.8	V
I _{OH} High-level output current			-12			-15	mA
I _{OL} Low-level output current			12			24	mA
T _A Operating free-air temperature	-55		125	0		70	°C

electrical characteristics over recommended operating free-air temperature range (unless otherwise noted)

PARAMETER	TEST CONDITIONS†	SN54LS'			SN74LS'			UNIT	
		MIN	TYP‡	MAX	MIN	TYP‡	MAX		
V _{IK} A or B	V _{CC} = MIN, I _I = -18 mA			-1.5			-1.5	V	
Hysteresis (V _{T+} - V _{T-})	V _{CC} = MIN	0.2	0.4		0.2	0.4		V	
V _{OH}	V _{CC} = MIN, V _{IH} = 2 V, V _{IL} = MAX, I _{OH} = -3 mA	2.4	3.1		2.4	3.1		V	
	V _{CC} = MIN, V _{IH} = 2 V, V _{IL} = 0.5 V, I _{OH} = MAX	2			2			V	
V _{OL}	V _{CC} = MIN, V _{IH} = 2 V, I _{OL} = 12 mA	0.25	0.4		0.25	0.4		V	
	V _{IL} = MAX, I _{OL} = 24 mA				0.35	0.5		V	
I _{OZH}	V _{CC} = MAX, V _{IH} = 2 V, V _O = 2.7 V			40			40	μA	
I _{OZL}	V _{IL} = MAX, V _O = 0.4 V			-200			-200	μA	
I _I	A or B			0.1			0.1	mA	
	GAB or GBA	V _{CC} = MAX, V _I = 5.5 V		0.1			0.1	mA	
I _{IH}	V _{CC} = MAX, V _I = 7 V			0.1			0.1	mA	
I _{IL}	V _{CC} = MAX, V _I = 2.7 V			20			20	μA	
	V _{CC} = MAX, V _I = 0.4 V, GAB and GBA at 0 V			-0.2			-0.2	mA	
	V _{CC} = MAX, V _I = 0.4 V, GAB and GBA at 4.5 V			-0.2			-0.2	mA	
	GAB or GBA	V _{CC} = MAX, V _I = 0.4 V			-0.2		-0.2	mA	
I _{OS} §	V _{CC} = MAX	-40		-225	-40		-225	mA	
I _{CC}	Outputs high			22	38		22	38	mA
	Outputs low	V _{CC} = MAX, Outputs open,		29	50		29	50	
	All outputs disabled	See Note 2		29	50		29	50	
				32	54		32	54	

† For conditions shown as MIN or MAX, use the appropriate value specified under recommended operating conditions.

‡ All typical values are at V_{CC} = 5 V, T_A = 25°C.

§ Not more than one output should be shorted at a time, and duration of the short-circuit should not exceed one second.

NOTE 2: I_{CC} is measured with transceivers enabled in one direction only, or with all transceivers disabled.

switching characteristics, V_{CC} = 5 V, T_A = 25°C

PARAMETER	TEST CONDITIONS	'LS242			'LS243			UNIT
		MIN	TYP	MAX	MIN	TYP	MAX	
t _{PLH}	R _L = 667 Ω, C _L = 45 pF, See Note 3		9	14		12	18	ns
t _{PHL}			12	18		12	18	ns
t _{PZL}			20	30		20	30	ns
t _{PZH}			15	23		15	23	ns
t _{PLZ}	R _L = 667 Ω, C _L = 5 pF, See Note 3		10	20		10	20	ns
t _{PHZ}			15	25		15	25	ns

NOTE 3: See General Information Section for load circuits and voltage waveforms.

TTL DEVICES

TYPES SN54LS245, SN74LS245 OCTAL BUS TRANSCEIVERS WITH 3-STATE OUTPUTS

OCTOBER 1976—REVISED APRIL 1985

- Bi-directional Bus Transceiver in a High-Density 20-Pin Package
- 3-State Outputs Drive Bus Lines Directly
- PNP Inputs Reduce D-C Loading on Bus Lines
- Hysteresis at Bus Inputs Improve Noise Margins
- Typical Propagation Delay Times, Port-to-Port . . . 8 ns

TYPE	I _{OL} (SINK CURRENT)	I _{OH} (SOURCE CURRENT)
SN54LS245	12 mA	-12 mA
SN74LS245	24 mA	-15 mA

description

These octal bus transceivers are designed for asynchronous two-way communication between data buses. The control function implementation minimizes external timing requirements.

The devices allow data transmission from the A bus to the B bus or from the B bus to the A bus depending upon the logic level at the direction control (DIR) input. The enable input (G) can be used to disable the device so that the buses are effectively isolated.

The SN54LS245 is characterized for operation over the full military temperature range of -55°C to 125°C. The SN74LS245 is characterized for operation from 0°C to 70°C.

schematics of inputs and outputs

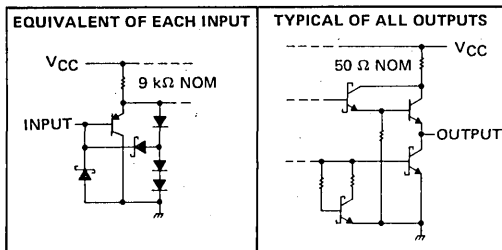

SN54LS245 . . . J PACKAGE
SN74LS245 . . . DW, J OR N PACKAGE
(TOP VIEW)

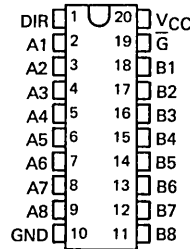

SN54LS245 . . . FK PACKAGE
SN74LS245 . . . FN PACKAGE
(TOP VIEW)

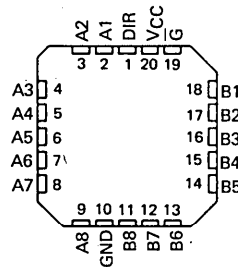

FUNCTION TABLE

ENABLE G	DIRECTION CONTROL DIR	OPERATION
L	L	B data to A bus
L	H	A data to B bus
H	X	Isolation

H = high level; L = low level; X = irrelevant

PRODUCTION DATA

This document contains information current as of publication date. Products conform to specifications per the terms of Texas Instruments standard warranty. Production processing does not necessarily include testing of all parameters.

**TEXAS
INSTRUMENTS**

POST OFFICE BOX 225012 • DALLAS, TEXAS 75265

TYPES SN54LS245, SN74LS245 OCTAL BUS TRANSCEIVERS WITH 3-STATE OUTPUTS

logic symbol

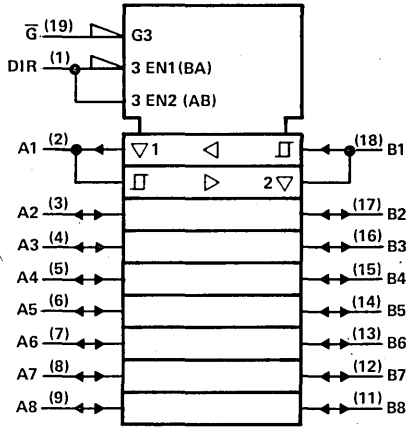

logic diagram (positive logic)

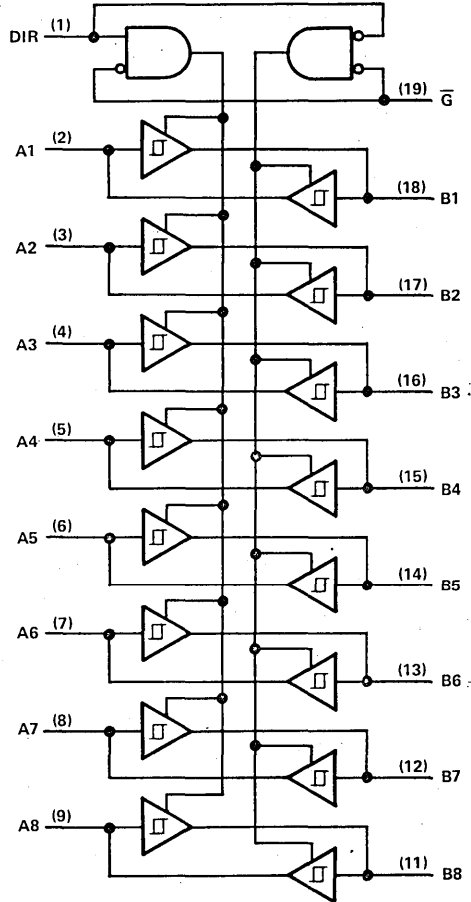

Pin numbers shown on logic notation are for DW, J or N packages.

absolute maximum ratings over operating free-air temperature range (unless otherwise noted)

Supply voltage, V_{CC} (see Note 1)	7 V
Input voltage	7 V
Off-state output voltage	5.5 V
Operating free-air temperature range: SN54LS'	-55°C to 125°C
SN74LS'	0°C to 70°C
Storage temperature range	-65°C to 150°C

NOTE 1: Voltage values are with respect to network ground terminal.

3
TTL DEVICES

TYPES SN54LS245, SN74LS245 OCTAL BUS TRANSCEIVERS WITH 3-STATE OUTPUTS

recommended operating conditions

PARAMETER	SN54LS245			SN74LS245			UNIT
	MIN	NOM	MAX	MIN	NOM	MAX	
Supply voltage, V_{CC}	4.5	5	5.5	4.75	5	5.25	V
High-level output current, I_{OH}			-12			-15	mA
Low-level output current, I_{OL}			12			24	mA
Operating free-air temperature, T_A	-55		125	0		70	°C

electrical characteristics over recommended operating free-air temperature range (unless otherwise noted)

PARAMETER	TEST CONDITIONS†	SN54LS245			SN74LS245			UNIT	
		MIN	TYP‡	MAX	MIN	TYP‡	MAX		
V_{IH} High-level input voltage		2			2			V	
V_{IL} Low-level input voltage				0.7			0.8	V	
V_{IK} Input clamp voltage	$V_{CC} = \text{MIN}, I_I = -18 \text{ mA}$			-1.5			-1.5	V	
Hysteresis ($V_{T+} - V_{T-}$)A or B input	$V_{CC} = \text{MIN}$	0.2	0.4		0.2	0.4		V	
V_{OH} High-level output voltage	$V_{CC} = \text{MIN}, V_{IH} = 2 \text{ V}, V_{IL} = V_{IL \text{ max}}$	$I_{OH} = -3 \text{ mA}$	2.4	3.4	2.4	3.4		V	
		$I_{OH} = \text{MAX}$	2		2				
V_{OL} Low-level output voltage	$V_{CC} = \text{MIN}, V_{IH} = 2 \text{ V}, V_{IL} = V_{IL \text{ max}}$	$I_{OL} = 12 \text{ mA}$		0.4		0.4		V	
		$I_{OL} = 24 \text{ mA}$				0.5			
I_{OZH} Off-state output current, high-level voltage applied	$V_{CC} = \text{MAX}, \bar{G} \text{ at } 2 \text{ V}$	$V_O = 2.7 \text{ V}$		20		20		μA	
I_{OZL} Off-state output current, low-level voltage applied		$V_O = 0.4 \text{ V}$		-200		-200			
I_I Input current at maximum input voltage	A or B DIR or \bar{G}	$V_{CC} = \text{MAX}$	$V_I = 5.5 \text{ V}$		0.1		0.1	mA	
			$V_I = 7 \text{ V}$		0.1		0.1		
I_{IH} High-level input current	$V_{CC} = \text{MAX}$	$V_{IH} = 2.7 \text{ V}$		20		20	μA		
I_{IL} Low-level input current	$V_{CC} = \text{MAX}$	$V_{IL} = 0.4 \text{ V}$		-0.2		-0.2	mA		
I_{OS} Short-circuit output current‡	$V_{CC} = \text{MAX}$			-40	-225	-40	-225	mA	
I_{CC} Supply current	Total, outputs high	$V_{CC} = \text{MAX}$	Outputs open		48	70	48	70	mA
	Total, outputs low				62	90	62	90	
	Outputs at Hi-Z				64	95	64	95	

† For conditions shown as MIN or MAX, use the appropriate value specified under recommended operating conditions.

‡ All typical values are at $V_{CC} = 5 \text{ V}, T_A = 25^\circ \text{C}$.

§ Not more than one output should be shorted at a time, and duration of the short-circuit should not exceed one second.

switching characteristics, $V_{CC} = 5 \text{ V}, T_A = 25^\circ \text{C}$

PARAMETER	TEST CONDITIONS	MIN	TYP	MAX	UNIT
t_{PLH} Propagation delay time, low-to-high-level output	$C_L = 45 \text{ pF}, R_L = 667 \Omega, \text{ See Note 2}$		8	12	ns
t_{PHL} Propagation delay time, high-to-low-level output			8	12	ns
t_{PZL} Output enable time to low level			27	40	ns
t_{PZH} Output enable time to high level			25	40	ns
t_{PLZ} Output disable time from low level		$C_L = 5 \text{ pF}, R_L = 667 \Omega, \text{ See Note 2}$		15	25
t_{PHZ} Output disable time from high level			15	28	ns

NOTE 2: See General Information Section for load circuits and voltage waveforms.

3

TTL DEVICES

TYPES SN54246 THRU SN54249, SN54LS247 THRU SN54LS249, SN74246 THRU SN74249, SN74LS247 THRU SN74LS249 BCD-TO-SEVEN-SEGMENT DECODERS/DRIVERS

MARCH 1974—REVISED DECEMBER 1983

- | | | |
|--|---|--|
| <p>'246, '247, 'LS247
feature</p> <ul style="list-style-type: none"> • Open-Collector Outputs Drive Indicators Directly • Lamp-Test Provision • Leading/Trailing Zero Suppression | <p>'248, 'LS248
feature</p> <ul style="list-style-type: none"> • Internal Pull-Ups Eliminate Need for External Resistors • Lamp-Test Provision • Leading/Trailing Zero Suppression | <p>'249, 'LS249
feature</p> <ul style="list-style-type: none"> • Open-Collector Outputs • Lamp-Test Provision • Leading/Trailing Zero Suppression |
|--|---|--|
- All Circuit Types Feature Lamp Intensity Modulation Capability

TYPE	DRIVER OUTPUTS				TYPICAL POWER DISSIPATION	PACKAGES
	ACTIVE LEVEL	OUTPUT CONFIGURATION	SINK CURRENT	MAX VOLTAGE		
SN54246	low	open-collector	40 mA	30 V	320 mW	J, W
SN54247	low	open-collector	40 mA	15 V	320 mW	J, W
SN54248	high	2-k Ω pull-up	6.4 mA	5.5 V	265 mW	J, W
SN54249	high	open-collector	10 mA	5.5 V	265 mW	J, W
SN54LS247	low	open-collector	12 mA	15 V	35 mW	J, W
SN54LS248	high	2-k Ω pull-up	2 mA	5.5 V	125 mW	J, W
SN54LS249	high	open-collector	4 mA	5.5 V	40 mW	J, W
SN74246	low	open-collector	40 mA	30 V	320 mW	J, N
SN74247	low	open-collector	40 mA	15 V	320 mW	J, N
SN74248	high	2-k Ω pull-up	6.4 mA	5.5 V	265 mW	J, N
SN74249	high	open-collector	10 mA	5.5 V	265 mW	J, N
SN74LS247	low	open-collector	24 mA	15 V	35 mW	J, N
SN74LS248	high	2-k Ω pull-up	6 mA	5.5 V	125 mW	J, N
SN74LS249	high	open-collector	8 mA	5.5 V	40 mW	J, N

SN54246 THRU SN54249
SN54LS247 THRU SN54LS249 ... J OR W PACKAGE
SN74246 THRU SN74249 ... J OR N PACKAGE
SN74LS247 THRU SN74LS249 ... D, J OR N PACKAGE

(TOP VIEW)

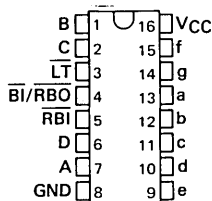

SN54LS247 THRU SN54LS249 ... FK PACKAGE
SN74LS247 THRU SN74LS249 ... FN PACKAGE
(TOP VIEW)

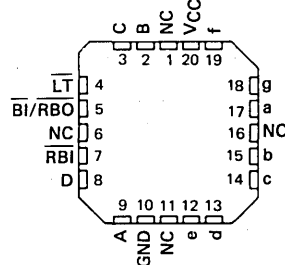

NC - No internal connection

description

The '246 through '248 are electrically and functionally identical to the SN5446A/SN7446A, SN5447A/SN7447A, and SN5448/SN7448, respectively, and have the same pin assignments as their equivalents. Also the 'LS247 and 'LS248 are electrically and functionally identical to the SN54LS47/SN74LS47 and SN54LS48/SN74LS48, respectively, and have the same pin assignments as their equivalents. They can be used interchangeably in present or future designs to offer designers a choice between two indicator fonts. The '249 and 'LS249 are 16-pin versions of the 14-pin SN5449 and SN54LS49/SN74LS49, respectively. Included in the '249 and 'LS249 circuits is the full functional capability for lamp test and ripple blanking, which is not available in the '49 and 'LS49 circuits. The '46A, '47A, '48, '49, 'LS47, 'LS48, and 'LS49 compose the \bar{b} and the \bar{c} without tails and the '246 through '249 and 'LS247, 'LS248, and 'LS249

PRODUCTION DATA

This document contains information current as of publication date. Products conform to specifications per the terms of Texas Instruments standard warranty. Production processing does not necessarily include testing of all parameters.

TEXAS
INSTRUMENTS

POST OFFICE BOX 225012 • DALLAS, TEXAS 75265

TYPES SN54246 THRU SN54249, SN54LS247 THRU SN54LS249, SN74246 THRU SN74249, SN74LS247 THRU SN74LS249 BCD-TO-SEVEN-SEGMENT DECODERS/DRIVERS

description (continued)

compose the \bar{B} and the \bar{C} with tails. Composition of all other characters, including display patterns for BCD inputs above nine, is identical. The '246, '247, and 'LS247 feature active-low outputs designed for driving indicators directly, and the '248, '249, 'LS248, and 'LS249 feature active-high outputs for driving lamp buffers. All of the circuits have full ripple-blanking input/output controls and a lamp test input. Segment identification and resultant displays are shown below. Display patterns for BCD input counts above 9 are unique symbols to authenticate input conditions.

All of these circuits incorporate automatic leading and/or trailing-edge zero-blanking control (\bar{RBI} and \bar{RBO}). Lamp test (\bar{LT}) of these types may be performed at any time when the \bar{BI}/\bar{RBO} node is at a high level. All types contain an overriding blanking input (\bar{BI}) which can be used to control the lamp intensity by pulsing or to inhibit the outputs. Inputs and outputs are entirely compatible for use with TTL logic outputs.

Series 54 and Series 54LS devices are characterized for operation over the full military temperature range of -55°C to 125°C ; Series 74 and Series 74LS devices are characterized for operation from 0°C to 70°C .

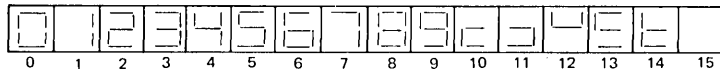
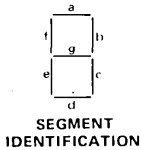

NUMERICAL DESIGNATIONS AND RESULTANT DISPLAYS

'246, '247, 'LS247
FUNCTION TABLE

DECIMAL OR FUNCTION	INPUTS						$\bar{BI}/\bar{RBO}^{\dagger}$	OUTPUTS							NOTE
	LT	\bar{RBI}	D	C	B	A		a	b	c	d	e	f	g	
0	H	H	L	L	L	L	H	ON	ON	ON	ON	ON	ON	OFF	1
1	H	X	L	L	L	H	H	OFF	ON	ON	OFF	OFF	OFF	OFF	
2	H	X	L	L	H	L	H	ON	ON	OFF	ON	ON	OFF	ON	
3	H	X	L	L	H	H	H	ON	ON	ON	ON	OFF	OFF	ON	
4	H	X	L	H	L	L	H	OFF	ON	ON	OFF	OFF	ON	ON	
5	H	X	L	H	L	H	H	ON	OFF	ON	ON	OFF	ON	ON	
6	H	X	L	H	H	L	H	ON	OFF	ON	ON	ON	ON	ON	
7	H	X	L	H	H	H	H	ON	ON	ON	OFF	OFF	OFF	OFF	
8	H	X	H	L	L	L	H	ON	ON	ON	ON	ON	ON	ON	
9	H	X	H	L	L	H	H	ON	ON	ON	ON	OFF	ON	ON	
10	H	X	H	L	H	L	H	OFF	OFF	OFF	ON	ON	OFF	ON	
11	H	X	H	L	H	H	H	OFF	OFF	ON	ON	OFF	OFF	ON	
12	H	X	H	H	L	L	H	OFF	ON	OFF	OFF	OFF	ON	ON	
13	H	X	H	H	L	H	H	ON	OFF	OFF	ON	OFF	ON	ON	
14	H	X	H	H	H	L	H	OFF	OFF	OFF	ON	ON	ON	ON	
15	H	X	H	H	H	H	H	OFF	OFF	OFF	OFF	OFF	OFF	OFF	
\bar{BI}	X	X	X	X	X	X	L	OFF	OFF	OFF	OFF	OFF	OFF	OFF	2
\bar{RBI}	H	L	L	L	L	L	L	OFF	OFF	OFF	OFF	OFF	OFF	OFF	3
\bar{LT}	L	X	X	X	X	X	H	ON	ON	ON	ON	ON	ON	ON	4

H = high level, L = low level, X = irrelevant

NOTES: 1. The blanking input (\bar{BI}) must be open or held at a high logic level when output functions 0 through 15 are desired. The ripple-blanking input (\bar{RBI}) must be open or high if blanking of a decimal zero is not desired.

2. When a low logic level is applied directly to the blanking input (\bar{BI}), all segment outputs are off regardless of the level of any other input.

3. When ripple-blanking input (\bar{RBI}) and inputs A, B, C, and D are at a low level with the lamp test input high, all segment outputs go off and the ripple-blanking output (\bar{RBO}) goes to a low level (response condition).

4. When the blanking input/ripple-blanking output (\bar{BI}/\bar{RBO}) is open or held high and a low is applied to the lamp-test input, all segment outputs are on.

$\dagger \bar{BI}/\bar{RBO}$ is wire-AND logic serving as blanking input (\bar{BI}) and/or ripple-blanking output (\bar{RBO}).

TYPES SN54248, SN54249, SN54LS248, SN54LS249,
SN74248, SN74249, SN74LS248, SN74LS249
BCD-TO-SEVEN-SEGMENT DECODERS/DRIVERS

'248, '249, 'LS248, 'LS249

FUNCTION TABLE

DECIMAL OR FUNCTION	INPUTS						$\overline{\text{BI/RBO}}^\dagger$	OUTPUTS							NOTE
	$\overline{\text{LT}}$	$\overline{\text{RBI}}$	D	C	B	A		a	b	c	d	e	f	g	
0	H	H	L	L	L	L	H	H	H	H	H	H	L	1	
1	H	X	L	L	L	H	H	L	H	H	L	L	L	1	
2	H	X	L	L	H	L	H	H	H	L	H	H	L	H	
3	H	X	L	L	H	H	H	H	H	H	H	L	L	H	
4	H	X	L	H	L	L	H	L	H	H	L	L	H	H	
5	H	X	L	H	L	H	H	H	L	H	H	L	H	H	
6	H	X	L	H	H	L	H	H	L	H	H	H	H	H	
7	H	X	L	H	H	H	H	H	H	H	L	L	L	L	
8	H	X	H	L	L	L	H	H	H	H	H	H	H	H	
9	H	X	H	L	L	H	H	H	H	H	H	L	H	H	
10	H	X	H	L	H	L	H	L	L	L	H	H	L	H	
11	H	X	H	L	H	H	H	L	L	H	H	L	L	H	
12	H	X	H	H	L	L	H	L	H	L	L	L	H	H	
13	H	X	H	H	L	H	H	H	L	L	H	L	H	H	
14	H	X	H	H	H	L	H	L	L	L	H	H	H	H	
15	H	X	H	H	H	H	H	L	L	L	L	L	L	L	
$\overline{\text{BI}}$	X	X	X	X	X	X	L	L	L	L	L	L	L	2	
$\overline{\text{RBI}}$	H	L	L	L	L	L	L	L	L	L	L	L	L	3	
$\overline{\text{LT}}$	L	X	X	X	X	X	H	H	H	H	H	H	H	4	

H = high level, L = low level, X = irrelevant

- NOTES: 1. The blanking input ($\overline{\text{BI}}$) must be open or held at a high logic level when output functions 0 through 15 are desired. The ripple-blanking input ($\overline{\text{RBI}}$) must be open or high if blanking of a decimal zero is not desired.
2. When a low logic level is applied directly to the blanking input ($\overline{\text{BI}}$), all segment outputs are low regardless of the level of any other input.
3. When ripple-blanking input ($\overline{\text{RBI}}$) and inputs A, B, C, and D are at a low level with the lamp test input high, all segment outputs go low and the ripple-blanking output ($\overline{\text{RBO}}$) goes to a low level (response condition).
4. When the blanking input/ripple-blanking output ($\overline{\text{BI/RBO}}$) is open or held high and a low is applied to the lamp-test input, all segment outputs are high.

$^\dagger \overline{\text{BI/RBO}}$ is wire-AND logic serving as blanking input ($\overline{\text{BI}}$) and/or ripple-blanking output ($\overline{\text{RBO}}$).



TTL DEVICES

**TYPES SN54246, SN54247, SN54LS247,
SN74246, SN74247, SN74LS247
BCD-TO-SEVEN-SEGMENT DECODERS/DRIVERS**

logic diagram

'246, '247, 'LS247

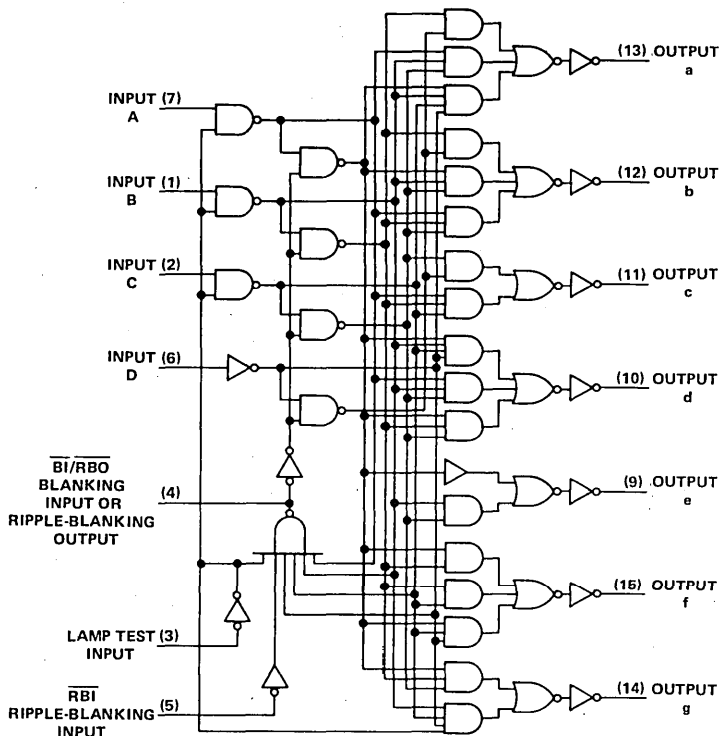

Pin numbers shown on logic notation are for D, J or N packages.

TYPES SN54248, SN54249, SN54LS248, SN54LS249,
 SN74248, SN74249, SN74LS248, SN74LS249
 BCD-TO-SEVEN-SEGMENT DECODERS/DRIVERS

logic diagrams

'248, '249, 'LS248, 'LS249

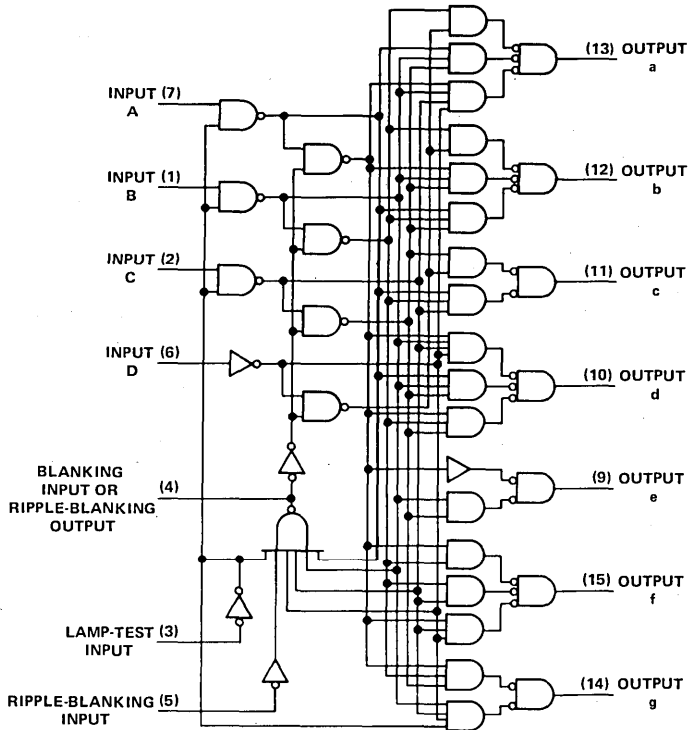

Pin numbers shown on logic notation are for D, J or N packages.

TYPES SN54246 THRU SN54249, SN74246 THRU SN74249
BCD-TO-SEVEN-SEGMENT DECODERS/DRIVERS

schematics of inputs and outputs

'246, '247, '248, '249

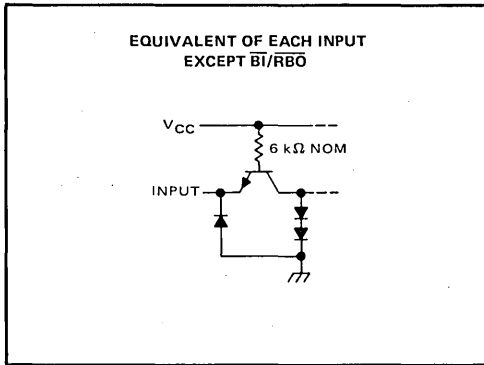

'246, '247, '248, '249

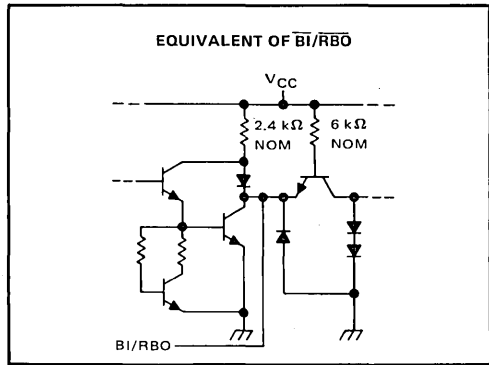

'246, '247

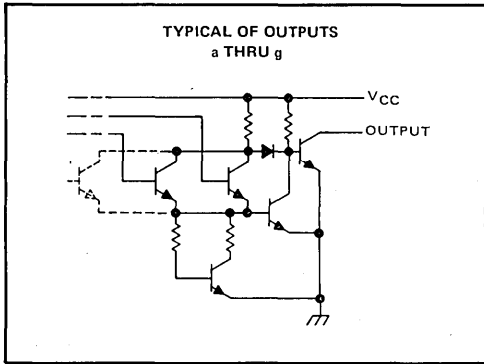

'248

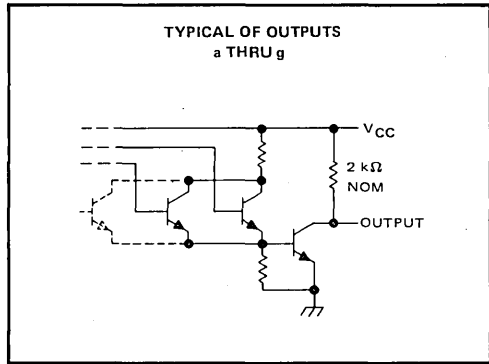

'249

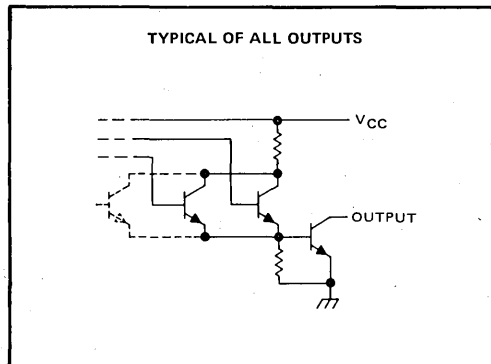

3 TTL DEVICES

TYPES SN54LS247 THRU SN54LS249, SN74LS247 THRU SN74LS249 BCD-TO-SEVEN-SEGMENT DECODERS/DRIVERS

schematics of inputs and outputs

'LS247, 'LS248, 'LS249

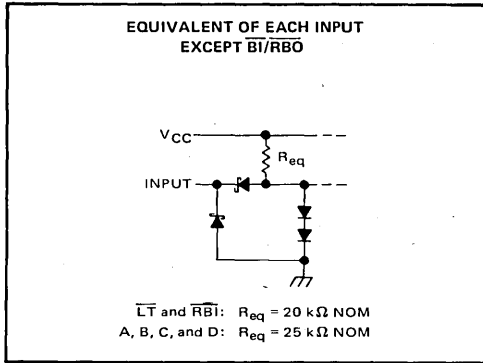

'LS247, 'LS248, 'LS249

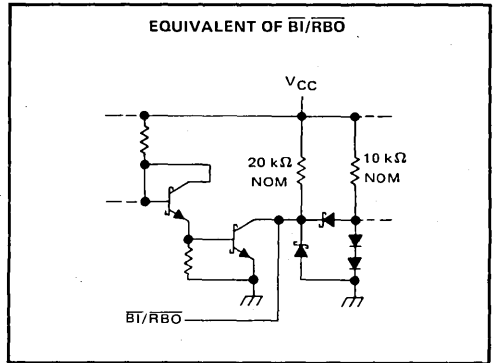

'LS247

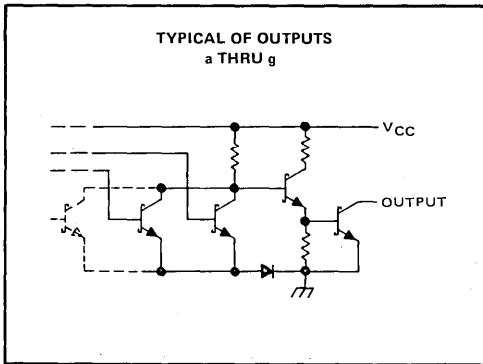

'LS248

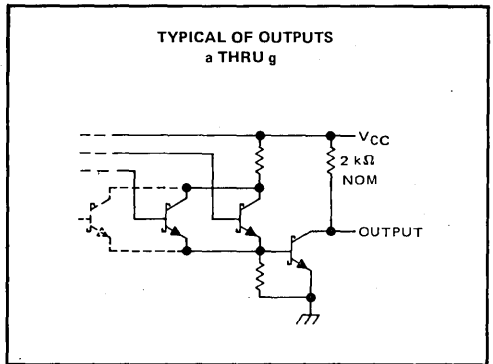

'LS249

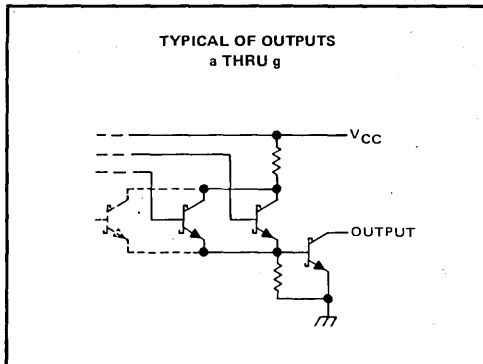

TYES SN54246, SN54247, SN74246, SN74247 BCD-TO-SEVEN-SEGMENT DECODERS/DRIVERS

absolute maximum ratings over operating free-air temperature range (unless otherwise noted)

Supply voltage, V_{CC} (see Note 1)	7 V
Input voltage	5.5 V
Current forced into any output in the off state	1 mA
Operating free-air temperature range: SN54246, SN54247	-55°C to 125°C
SN74246, SN74247	0°C to 70°C
Storage temperature range	-65°C to 150°C

NOTE 1: Voltage values are with respect to network ground terminal.

recommended operating conditions

	SN54246			SN54247			SN74246			SN74247			UNIT
	MIN	NOM	MAX	MIN	NOM	MAX	MIN	NOM	MAX	MIN	NOM	MAX	
Supply voltage, V_{CC}	4.5	5	5.5	4.5	5	5.5	4.75	5	5.25	4.75	5	5.25	V
Off-state output voltage, $V_{O(off)}$	a thru g			30			15			30			V
On-state output current, $I_{O(on)}$	a thru g			40			40			40			mA
High-level output current, I_{OH}	$\overline{BI}/\overline{RBO}$			-200			-200			-200			μ A
Low-level output current, I_{OL}	$\overline{BI}/\overline{RBO}$			8			8			8			mA
Operating free-air temperature, T_A	-55			125			0			70			°C

electrical characteristics over recommended operating free-air temperature range (unless otherwise noted)

PARAMETER				TEST CONDITIONS†		MIN	TYP‡	MAX	UNIT
V_{IH}	High-level input voltage					2			V
V_{IL}	Low-level input voltage							0.8	V
V_{IK}	Input clamp voltage			$V_{CC} = \text{MIN}, I_I = -12 \text{ mA}$				1.5	V
V_{OH}	High-level output voltage	$\overline{BI}/\overline{RBO}$		$V_{CC} = \text{MIN}, V_{IH} = 2 \text{ V}, V_{IL} = 0.8 \text{ V}, I_{OH} = -200 \mu\text{A}$		2.4	3.7		V
V_{OL}	Low-level output voltage	$\overline{BI}/\overline{RBO}$		$V_{CC} = \text{MIN}, V_{IH} = 2 \text{ V}, V_{IL} = 0.8 \text{ V}, I_{OL} = 8 \text{ mA}$		0.27		0.4	V
$I_{O(off)}$	Off-state output current	a thru g		$V_{CC} = \text{MAX}, V_{IH} = 2 \text{ V}, V_{IL} = 0.8 \text{ V}, V_{O(off)} = \text{MAX}$				250	μ A
$V_{O(on)}$	On-state output voltage	a thru g		$V_{CC} = \text{MIN}, V_{IH} = 2 \text{ V}, V_{IL} = 0.8 \text{ V}, I_{O(on)} = 40 \text{ mA}$		0.3		0.4	V
I_I	Input current at maximum input voltage	Any input except $\overline{BI}/\overline{RBO}$		$V_{CC} = \text{MAX}, V_I = 5.5 \text{ V}$				1	mA
I_{IH}	High-level input current	Any input except $\overline{BI}/\overline{RBO}$		$V_{CC} = \text{MAX}, V_I = 2.4 \text{ V}$				40	μ A
I_{IL}	Low-level input current	Any input except $\overline{BI}/\overline{RBO}$		$V_{CC} = \text{MAX}, V_I = 0.4 \text{ V}$				-1.6	mA
		$\overline{BI}/\overline{RBO}$							
I_{OS}	Short-circuit output current	$\overline{BI}/\overline{RBO}$		$V_{CC} = \text{MAX}$				-4	mA
I_{CC}	Supply current			$V_{CC} = \text{MAX}, \text{ See Note 2}$		64		103	mA

†For conditions shown as MIN or MAX, use the appropriate value specified under recommended operating conditions.

‡All typical values are at $V_{CC} = 5 \text{ V}, T_A = 25^\circ\text{C}$.

NOTE 2: I_{CC} is measured with all outputs open and all inputs at 4.5 V.

switching characteristics, $V_{CC} = 5 \text{ V}, T_A = 25^\circ\text{C}$

PARAMETER		TEST CONDITIONS		MIN	TYP	MAX	UNIT
t_{off}	Turn-off time from A input	$C_L = 15 \text{ pF}, R_L = 120 \Omega,$ See Note 3				100	ns
t_{on}	Turn-on time from A input					100	
t_{off}	Turn-off time from $\overline{RB1}$ input					100	ns
t_{on}	Turn-on time from $\overline{RB1}$ input					100	

NOTE 3: See General Information Section for load circuits and voltage waveforms.

TYPES SN54LS247, SN74LS247 BCD-TO-SEVEN-SEGMENT DECODERS/DRIVERS

absolute maximum ratings over operating free-air temperature range (unless otherwise noted)

Supply voltage, V_{CC} (see Note 1)	7 V
Input voltage	7 V
Peak output current ($t_w \leq 1$ ms, duty cycle $\leq 10\%$)	200 mA
Current forced into any output in the off state	1 mA
Operating free-air temperature range: SN54LS247	-55°C to 125°C
SN74LS247	0°C to 70°C
Storage temperature range	-65°C to 150°C

NOTE 1: Voltage values are with respect to network ground terminal.

recommended operating conditions

	SN54LS247			SN74LS247			UNIT
	MIN	NOM	MAX	MIN	NOM	MAX	
Supply voltage, V_{CC}	4.5	5	5.5	4.75	5	5.25	V
Off-state output voltage, $V_{O(off)}$	a thru g			15			V
On-state output current, $I_{O(on)}$	a thru g			12			mA
High-level output current, I_{OH}	BI/RBO			-50			μ A
Low-level output current, I_{OL}	BI/RBO			1.6			mA
Operating free-air temperature, T_A	-55			125			°C

electrical characteristics over recommended operating free-air temperature range (unless otherwise noted)

PARAMETER	TEST CONDITIONS†	SN54LS247			SN74LS247			UNIT
		MIN	TYP‡	MAX	MIN	TYP‡	MAX	
V_{IH} High-level input voltage		2			2			V
V_{IL} Low-level input voltage		0.7			0.8			V
V_{IK} Input clamp voltage		-1.5			-1.5			V
V_{OH} High-level output voltage	BI/RBO $V_{CC} = \text{MIN}, I_I = -18 \text{ mA}$ $V_{IL} = V_{IL \text{ max}}, I_{OH} = -50 \mu\text{A}$	2.4	4.2		2.4	4.2	V	
V_{OL} Low-level output voltage	BI/RBO $V_{CC} = \text{MIN}, I_{OH} = 2 \text{ V}, I_{OL} = 1.6 \text{ mA}$ $V_{IL} = V_{IL \text{ max}}, I_{OL} = 3.2 \text{ mA}$	0.25	0.4		0.25	0.4	V	
$I_{O(off)}$ Off-state output current	a thru g $V_{CC} = \text{MAX}, V_{IH} = 2 \text{ V}, V_{IL} = V_{IL \text{ max}}, V_{O(off)} = 15 \text{ V}$	250			250			μ A
$V_{O(on)}$ On-state output voltage	a thru g $V_{CC} = \text{MIN}, V_{IH} = 2 \text{ V}, V_{IL} = V_{IL \text{ max}}, I_{O(on)} = 12 \text{ mA}$ $I_{O(on)} = 24 \text{ mA}$	0.25	0.4		0.25	0.4	V	
I_I Input current at maximum input voltage	$V_{CC} = \text{MAX}, V_I = 7 \text{ V}$	0.1			0.1			mA
I_{IH} High-level input current	$V_{CC} = \text{MAX}, V_I = 2.7 \text{ V}$	20			20			μ A
I_{IL} Low-level input current	Any input except BI/RBO	$V_{CC} = \text{MAX}, V_I = 0.4 \text{ V}$			-0.4			mA
	BI/RBO				-1.2			mA
I_{OS} Short-circuit output current	BI/RBO $V_{CC} = \text{MAX}$	-0.3	-2		-0.3	-2	mA	
I_{CC} Supply current	$V_{CC} = \text{MAX},$ See Note 2	7	13		7	13	mA	

† For conditions shown as MIN or MAX, use the appropriate value specified under recommended operating conditions.

‡ All typical values are at $V_{CC} = 5 \text{ V}, T_A = 25^\circ\text{C}$.

NOTE 2: I_{CC} is measured with all outputs open and all inputs at 4.5 V.

switching characteristics, $V_{CC} = 5 \text{ V}, T_A = 25^\circ\text{C}$

PARAMETER	TEST CONDITIONS	MIN	TYP	MAX	UNIT
t_{off} Turn-off time from A input	$C_L = 15 \text{ pF}, R_L = 665 \Omega,$ See Note 3	100			ns
t_{on} Turn-on time from A input		100			
t_{off} Turn-off time from RBI input		100			ns
t_{on} Turn-on time from RBI input		100			

NOTE 3: See General Information Section for load circuits and voltage waveforms.

TYPES SN54248, SN74248

BCD-TO-SEVEN-SEGMENT DECODERS/DRIVERS

absolute maximum ratings over operating free-air temperature range (unless otherwise noted)

Supply voltage, V_{CC} (see Note 1)	7 V
Input voltage	5.5 V
Operating free-air temperature range: SN54248	-55°C to 125°C
SN74248	0°C to 70°C
Storage temperature range	-65°C to 150°C

NOTE 1: Voltage values are with respect to network ground terminals.

recommended operating conditions

	SN54248			SN74248			UNIT		
	MIN	NOM	MAX	MIN	NOM	MAX			
Supply voltage, V_{CC}	4.5	5	5.5	4.75	5	5.25	V		
High-level output current, I_{OH}	a thru g			-400			μ A		
	$\overline{BI}/\overline{RBO}$			-200					
Low-level output current, I_{OL}	a thru g			6.4			mA		
	$\overline{BI}/\overline{RBO}$			8					
Operating free-air temperature, T_A	-55			125			0	70	°C

electrical characteristics over recommended operating free-air temperature range (unless otherwise noted)

PARAMETER		TEST CONDITIONS [†]	MIN	TYP [‡]	MAX	UNIT	
V_{IH}	High-level input voltage		2			V	
V_{IL}	Low-level input voltage				0.8	V	
V_{IK}	Input clamp voltage	$V_{CC} = \text{MIN}, I_I = -12 \text{ mA}$			-1.5	V	
V_{OH}	High-level output voltage	a thru g	$V_{CC} = \text{MIN}, V_{IH} = 2 \text{ V},$		2.4	4.2	V
		$\overline{BI}/\overline{RBO}$	$V_{IL} = 0.8 \text{ V}, I_{OH} = \text{MAX}$		2.4	3.7	
I_O	Output current	a thru g	$V_{CC} = \text{MIN}, V_O = 0.85 \text{ V},$ Input conditions as for V_{OH}		-1.3	-2	mA
V_{OL}	Low-level output voltage	$V_{CC} = \text{MIN}, V_{IH} = 2 \text{ V},$ $V_{IL} = 0.8 \text{ V}, I_{OL} = \text{MAX}$	0.27		0.4	V	
I_I	Input current at maximum input voltage	Any input except $\overline{BI}/\overline{RBO}$	$V_{CC} = \text{MAX}, V_I = 5.5 \text{ V}$			1	mA
I_{IH}	High-level input current	Any input except $\overline{BI}/\overline{RBO}$	$V_{CC} = \text{MAX}, V_I = 2.4 \text{ V}$			40	μ A
I_{IL}	Low-level input current	Any input except $\overline{BI}/\overline{RBO}$	$V_{CC} = \text{MAX}, V_I = 0.4 \text{ V}$			-1.6	mA
		$\overline{BI}/\overline{RBO}$				-4	
I_{OS}	Short-circuit output current	$\overline{BI}/\overline{RBO}$	$V_{CC} = \text{MAX}$			-4	mA
I_{CC}	Supply current	$V_{CC} = \text{MAX},$ See Note 2	53		90	mA	

[†]For conditions shown as MIN or MAX, use the appropriate value specified under recommended operating conditions.

[‡]All typical values are at $V_{CC} = 5 \text{ V}, T_A = 25^\circ\text{C}$.

NOTE 2: I_{CC} is measured with all outputs open and all inputs at 4.5 V.

switching characteristics, $V_{CC} = 5 \text{ V}, T_A = 25^\circ\text{C}$

PARAMETER		TEST CONDITIONS	MIN	TYP	MAX	UNIT
t_{PHL}	Propagation delay time, high-to-low-level output from A input	$C_L = 15 \text{ pF}, R_L = 1 \text{ k}\Omega,$ See Note 3			100	ns
t_{PLH}	Propagation delay time, low-to-high-level output from A input				100	
t_{PHL}	Propagation delay time, high-to-low-level output from \overline{RBI} input				100	ns
t_{PLH}	Propagation delay time, low-to-high-level output from \overline{RBI} input				100	

NOTE 3: See General Information Section for load circuits and voltage waveforms.

TYPES SN54LS248, SN74LS248 BCD-TO-SEVEN-SEGMENT DECODERS/DRIVERS

absolute maximum ratings over operating free-air temperature range (unless otherwise noted)

Supply voltage, V_{CC} (see Note 1)	7 V
Input voltage	7 V
Operating free-air temperature range: SN54LS248	-55°C to 125°C
SN74LS248	0°C to 70°C
Storage temperature range	-65°C to 150°C

NOTE 1: Voltage values are with respect to network ground terminal.

recommended operating conditions

	SN54LS248			SN74LS248			UNIT
	MIN	NOM	MAX	MIN	NOM	MAX	
Supply voltage, V_{CC}	4.5	5	5.5	4.75	5	5.25	V
High-level output current, I_{OH}	a thru g			-100			μ A
	$\overline{BI}/\overline{RBO}$			-50			
Low-level output current, I_{OL}	a thru g			2			mA
	$\overline{BI}/\overline{RBO}$			1.6			
Operating free-air temperature, T_A	-55		125	0		70	°C

electrical characteristics over recommended operating free-air temperature range (unless otherwise noted)

PARAMETER		TEST CONDITIONS†	SN54LS248			SN74LS248			UNIT			
			MIN	TYP‡	MAX	MIN	TYP‡	MAX				
V_{IH}	High-level input voltage		2			2			V			
V_{IL}	Low-level input voltage		0.7			0.8			V			
V_{IK}	Input clamp voltage	$V_{CC} = \text{MIN}, I_I = -18 \text{ mA}$	-1.5			-1.5			V			
V_{OH}	High-level output voltage	a thru g and $\overline{BI}/\overline{RBO}$ $V_{CC} = \text{MIN}, V_{IH} = 2 \text{ V}, V_{IL} = V_{IL \text{ max}}, I_{OH} = \text{MAX}$	2.4	4.2		2.4	4.2		V			
I_O	Output current	a thru g $V_{CC} = \text{MIN}, V_O = 0.85 \text{ V},$ Input conditions as for V_{OH}	-1.3	-2		-1.3	-2		mA			
V_{OL}	Low-level output voltage	a thru g	$V_{CC} = \text{MIN}, V_{IH} = 2 \text{ V}, V_{IL} = V_{IL \text{ max}}, I_{OL} = 2 \text{ mA}$		0.25	0.4	0.25	0.4	V			
			$I_{OL} = 6 \text{ mA}$				0.35	0.5				
		$\overline{BI}/\overline{RBO}$	$V_{CC} = \text{MIN}, V_{IH} = 2 \text{ V}, V_{IL} = V_{IL \text{ max}}, I_{OL} = 1.6 \text{ mA}$		0.25		0.4		0.25		0.4	
			$I_{OL} = 3.2 \text{ mA}$				0.35		0.5			
I_I	Input current at maximum input voltage	Any input except $\overline{BI}/\overline{RBO}$ $V_{CC} = \text{MAX}, V_I = 7 \text{ V}$	0.1			0.1			mA			
I_{IH}	High-level input current	Any input except $\overline{BI}/\overline{RBO}$ $V_{CC} = \text{MAX}, V_I = 2.7 \text{ V}$	20			20			μ A			
I_{IL}	Low-level input current	Any input except $\overline{BI}/\overline{RBO}$ $V_{CC} = \text{MAX}, V_I = 0.4 \text{ V}$	-0.4			-0.4			mA			
			-1.2			-1.2						
I_{OS}	Short-circuit output current	$\overline{BI}/\overline{RBO}$ $V_{CC} = \text{MAX}$	-0.3	-2		-0.3	-2		mA			
I_{CC}	Supply current	$V_{CC} = \text{MAX},$ See Note 2	25	38		25	38		mA			

†For conditions shown as MIN or MAX, use the appropriate value specified under recommended operating conditions.

‡All typical values are at $V_{CC} = 5 \text{ V}, T_A = 25^\circ\text{C}$.

NOTE 2: I_{CC} is measured with all outputs open and all inputs at 4.5 V.

switching characteristics, $V_{CC} = 5 \text{ V}, T_A = 25^\circ\text{C}$

PARAMETER	TEST CONDITIONS	MIN	TYP	MAX	UNIT
t_{pHL}	Propagation delay time, high-to-low-level output from A input $C_L = 15 \text{ pF}, R_L = 4 \text{ k}\Omega,$			100	ns
t_{pLH}	Propagation delay time, low-to-high-level output from A input See Note 3			100	
t_{pHL}	Propagation delay time, high-to-low-level output from $\overline{RB1}$ input $C_L = 15 \text{ pF}, R_L = 6 \text{ k}\Omega,$			100	ns
t_{pLH}	Propagation delay time, low-to-high-level output from $\overline{RB1}$ input See Note 3			100	

NOTE 3: See General Information Section for load circuits and voltage waveforms.



TYPES SN54249, SN74249

BCD-TO-SEVEN-SEGMENT DECODERS/DRIVERS

absolute maximum ratings over operating free-air temperature range (unless otherwise noted)

Supply voltage, V_{CC} (see Note 1)	7 V
Input voltage	5.5 V
Current forced into any output in the off state	1 mA
Operating free-air temperature range: SN54249	-55°C to 125°C
SN74249	0°C to 70°C
Storage temperature range	-65°C to 150°C

NOTE 1: Voltage values are with respect to network ground terminal.

recommended operating conditions

	SN54249			SN74249			UNIT		
	MIN	NOM	MAX	MIN	NOM	MAX			
Supply voltage, V_{CC}	4.5	5	5.5	4.75	5	5.25	V		
High-level output voltage, V_{OH}	5.5			5.5			V		
High-level output current, I_{OH}	$\overline{BI}/\overline{RBO}$			-200			μA		
Low-level output current, I_{OL}	a thru g			10			mA		
	$\overline{BI}/\overline{RBO}$			8					
Operating free-air temperature, T_A	-55			125			0	70	°C

electrical characteristics over recommended operating free-air temperature range (unless otherwise noted)

PARAMETER		TEST CONDITIONS†	MIN	TYP‡	MAX	UNIT	
V_{IH}	High-level input voltage		2			V	
V_{IL}	Low-level input voltage				0.8	V	
V_{IK}	Input clamp voltage	$V_{CC} = \text{MIN}, I_I = -12 \text{ mA}$			-1.5	V	
V_{OH}	High-level output voltage	$\overline{BI}/\overline{RBO}$	$V_{CC} = \text{MIN}, V_{IH} = 2 \text{ V}, V_{IL} = 0.8 \text{ V}, I_{OH} = \text{MAX}$	2.4	3.7	V	
I_{OH}	High-level output current	a thru g	$V_{CC} = \text{MIN}, V_{IH} = 2 \text{ V}, V_{IL} = 0.8 \text{ V}, V_{OH} = 5.5 \text{ V}$			250	μA
V_{OL}	Low-level output voltage		$V_{CC} = \text{MIN}, V_{IH} = 2 \text{ V}, V_{IL} = 0.8 \text{ V}, I_{OL} = \text{MAX}$	0.27	0.4	V	
I_I	Input current at maximum input voltage	Any input except $\overline{BI}/\overline{RBO}$	$V_{CC} = \text{MAX}, V_I = 5.5 \text{ V}$			1	mA
I_{IH}	High-level input current	Any input except $\overline{BI}/\overline{RBO}$	$V_{CC} = \text{MAX}, V_I = 2.4 \text{ V}$			40	μA
I_{IL}	Low-level input current	Any input except $\overline{BI}/\overline{RBO}$	$V_{CC} = \text{MAX}, V_I = 0.4 \text{ V}$			-1.6	mA
		$\overline{BI}/\overline{RBO}$				-4	
I_{OS}	Short-circuit output current	$\overline{BI}/\overline{RBO}$	$V_{CC} = \text{MAX}$			-4	mA
I_{CC}	Supply current		$V_{CC} = \text{MAX}$, See Note 2	53	90	mA	

† For conditions shown as MIN or MAX, use the appropriate value specified under recommended operating conditions.

‡ All typical values are at $V_{CC} = 5 \text{ V}, T_A = 25^\circ \text{C}$.

NOTE 2: I_{CC} is measured with all outputs open and all inputs at 4.5 V.

switching characteristics, $V_{CC} = 5 \text{ V}, T_A = 25^\circ \text{C}$

PARAMETER		TEST CONDITIONS	MIN	TYP	MAX	UNIT
t_{PHL}	Propagation delay time, high-to-low-level output from A input	$C_L = 15 \text{ pF}, R_L = 667 \Omega,$ See Note 3			100	ns
t_{PLH}	Propagation delay time, low-to-high-level output from A input				100	
t_{PHL}	Propagation delay time, high-to-low-level output from \overline{RBI} input				100	ns
t_{PLH}	Propagation delay time, low-to-high-level output from \overline{RBI} input				100	

NOTE 3: See General Information Section for load circuits and voltage waveforms.

TYPES SN54LS249, SN74LS249 BCD-TO-SEVEN-SEGMENT DECODERS/DRIVERS

absolute maximum ratings over operating free-air temperature range (unless otherwise noted)

Supply voltage, V_{CC} (see Note 1)	7 V
Input voltage	7 V
Current forced into any output in the offstate	1 mA
Operating free-air temperature range: SN54LS249	-55°C to 125°C
SN74LS249	0°C to 70°C
Storage temperature range	-65°C to 150°C

NOTE 1: Voltage values are with respect to network ground terminal.

recommended operating conditions

	SN54LS249			SN74LS249			UNIT
	MIN	NOM	MAX	MIN	NOM	MAX	
Supply voltage, V_{CC}	4.5	5	5.5	4.75	5	5.25	V
High-level output voltage, V_{OH}	a thru g			5.5			5.5 V
High-level output current, I_{OH}	BI/RBO			-50			-50 μ A
Low-level output current, I_{OL}	a thru g			4			8 mA
	BI/RBO			1.6			3.2
Operating free-air temperature, T_A	-55			125			0 to 70 °C

electrical characteristics over recommended operating free-air temperature range (unless otherwise noted)

PARAMETER		TEST CONDITIONS†		SN54LS249			SN74LS249			UNIT
				MIN	TYP‡	MAX	MIN	TYP‡	MAX	
V_{IH}	High-level input voltage			2			2			V
V_{IL}	Low-level input voltage			0.7			0.8			V
V_{IK}	Input clamp voltage	$V_{CC} = \text{MIN}, I_I = -18 \text{ mA}$		-1.5			-1.5			V
V_{OH}	High-level output voltage	BI/RBO	$V_{CC} = \text{MIN}, V_{IH} = 2 \text{ V}, V_{IL} = V_{IL \text{ max}}, I_{OH} = -50 \mu\text{A}$	2.4	4.2		2.4	4.2		V
I_{OH}	High-level output current	a thru g	$V_{CC} = \text{MIN}, V_{IH} = 2 \text{ V}, V_{IL} = V_{IL \text{ max}}, V_{OH} = 5.5 \text{ V}$	250			250			μ A
V_{OL}	Low-level output voltage	BI/RBO	$V_{CC} = \text{MIN}, V_{IH} = 2 \text{ V}, V_{IL} = V_{IL \text{ max}}$	0.25	0.4		0.25	0.4		V
		a thru g	$V_{CC} = \text{MIN}, V_{IH} = 2 \text{ V}, V_{IL} = V_{IL \text{ max}}$	0.25 0.4			0.35 0.5			V
I_I	Input current at maximum input voltage	Any input except BI/RBO	$V_{CC} = \text{MAX}, V_I = 7 \text{ V}$	0.1			0.1			mA
I_{IH}	High-level input current	Any input except BI/RBO	$V_{CC} = \text{MAX}, V_I = 2.7 \text{ V}$	20			20			μ A
I_{IL}	Low-level input current	Any input except BI/RBO	$V_{CC} = \text{MAX}, V_I = 0.4 \text{ V}$	-0.4			-0.4			mA
		BI/RBO		-1.2			-1.2			
I_{OS}	Short-circuit output current	BI/RBO	$V_{CC} = \text{MAX}$	-0.3	-2		-0.3	-2		mA
I_{CC}	Supply current	$V_{CC} = \text{MAX},$ See Note 2		8	15		8	15		mA

†For conditions shown as MIN or MAX, use the appropriate value specified under recommended operating conditions.

‡All typical values are at $V_{CC} = 5 \text{ V}, T_A = 25^\circ\text{C}$.

NOTE 2: I_{CC} is measured with all outputs open and inputs at 4.5 V.

switching characteristics, $V_{CC} = 5 \text{ V}, T_A = 25^\circ\text{C}$

PARAMETER		TEST CONDITIONS	MIN	TYP	MAX	UNIT
t_{PHL}	Propagation delay time, high-to-low-level output from A input	$C_L = 15 \text{ pF}, R_L = 2 \text{ k}\Omega,$			100	ns
t_{PLH}	Propagation delay time, low-to-high-level output from A input	See Note 3			100	
t_{PHL}	Propagation delay time, high-to-low-level output from $\overline{\text{RB1}}$ input	$C_L = 15 \text{ pF}, R_L = 6 \text{ k}\Omega,$			100	ns
t_{PLH}	Propagation delay time, low-to-high-level output from $\overline{\text{RB1}}$ input	See Note 3			100	

NOTE 3: See General Information Section for load circuits and voltage waveforms.



TTL DEVICES 3

3

TTL DEVICES

TYPES SN54251, SN54LS251, SN54S251, SN74251, SN74LS251 (TIM9905), SN74S251 DATA SELECTORS/MULTIPLEXERS WITH 3-STATE OUTPUTS

DECEMBER 1972—REVISED APRIL 1985

- Three-State Versions of '151, 'LS151, 'S151
- Three-State Outputs Interface Directly with System Bus
- Perform Parallel-to-Serial Conversion
- Permit Multiplexing from N-lines to One Line
- Complementary Outputs Provide True and Inverted Data
- Fully Compatible with Most TTL Circuits

SN54251, SN54LS251, SN54S251 . . . J OR W PACKAGE
SN74251 . . . J OR N PACKAGE
SN74LS251, SN74S251 . . . D, J OR N PACKAGE
(TOP VIEW)

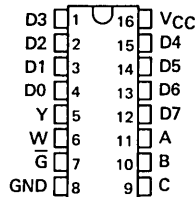

SN54LS251, SN54S251 . . . FK PACKAGE
SN74LS251, SN74S251 . . . FN PACKAGE
(TOP VIEW)

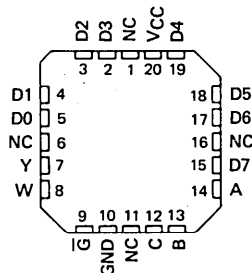

NC - No internal connection

TYPE	MAX NO. OF COMMON OUTPUTS	TYPICAL AVG PROP DELAY TIME (D TO Y)	TYPICAL POWER DISSIPATION
SN54251	49	17 ns	250 mW
SN74251	129	17 ns	250 mW
SN54LS251	49	17 ns	35 mW
SN74LS251	129	17 ns	35 mW
SN54S251	39	8 ns	275 mW
SN74S251	129	8 ns	275 mW

description

These monolithic data selectors/multiplexers contain full on-chip binary decoding to select one-of-eight data sources and feature a strobe-controlled three-state output. The strobe must be at a low logic level to enable these devices. The three-state outputs permit a number of outputs to be connected to a common bus. When the strobe input is high, both outputs are in a high-impedance state in which both the upper and lower transistors of each totem-pole output are off, and the output neither drives nor loads the bus significantly. When the strobe is low, the outputs are activated and operate as standard TTL totem-pole outputs.

To minimize the possibility that two outputs will attempt to take a common bus to opposite logic levels, the output control circuitry is designed so that the average output disable time is shorter than the average output enable time. The SN54251 and SN74251 have output clamp diodes to attenuate reflections on the bus line.

FUNCTION TABLE

INPUTS				OUTPUTS	
SELECT		ENABLE		Y	W
C	B	A	\bar{G}		
X	X	X	H	Z	Z
L	L	L	L	D0	$\bar{D}0$
L	L	H	L	D1	$\bar{D}1$
L	H	L	L	D2	$\bar{D}2$
L	H	H	L	D3	$\bar{D}3$
H	L	L	L	D4	$\bar{D}4$
H	L	H	L	D5	$\bar{D}5$
H	H	L	L	D6	$\bar{D}6$
H	H	H	L	D7	$\bar{D}7$

H = high logic level, L = low logic level
X = irrelevant, Z = high impedance (off)
D0, D1 . . . D7 = the level of the respective D input

PRODUCTION DATA
This document contains information current as of publication date. Products conform to specifications per the terms of Texas Instruments standard warranty. Production processing does not necessarily include testing of all parameters.

TEXAS INSTRUMENTS

POST OFFICE BOX 225012 • DALLAS, TEXAS 75265

**TYPES SN54251, SN54LS251, SN54S251,
SN74251, SN74LS251 (TIM9905), SN74S251
DATA SELECTORS/MULTIPLEXERS WITH 3-STATE OUTPUTS**

logic diagram

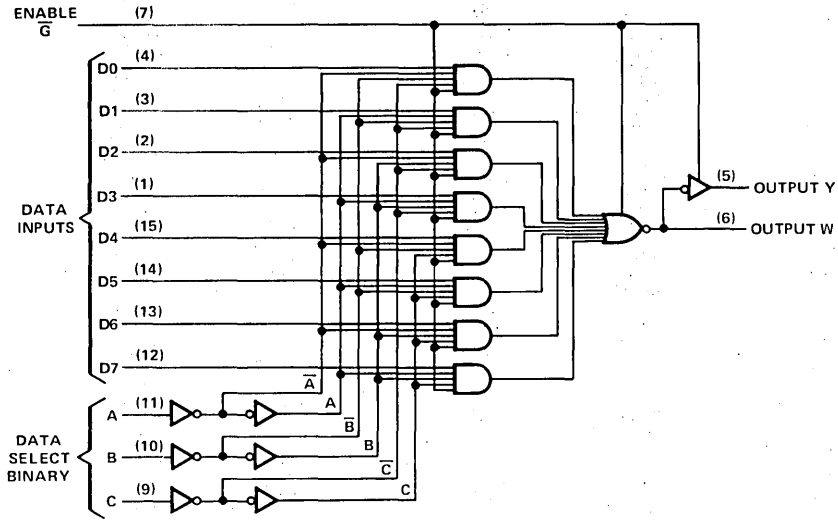

Pin numbers shown on logic notation are for D, J or N packages.

3

TTL DEVICES

TYPES SN54251, SN74251

DATA SELECTORS/MULTIPLEXERS WITH 3-STATE OUTPUTS

absolute maximum ratings over operating free-air temperature range (unless otherwise noted)

Supply voltage, V_{CC} (see Note 1)	7 V
Input voltage	5.5 V
Off-state output voltage	5.5 V
Operating free-air temperature range: SN54251	-55°C to 125°C
SN74251	0°C to 70°C
Storage temperature range	-65°C to 150°C

NOTE 1: Voltage values are with respect to network ground terminal.

recommended operating conditions

	SN54251			SN74251			UNIT
	MIN	NOM	MAX	MIN	NOM	MAX	
Supply voltage, V_{CC}	4.5	5	5.5	4.75	5	5.25	V
High-level output current, I_{OH}			-2			-5.2	mA
Low-level output current, I_{OL}			16			16	mA
Operating free-air temperature, T_A	-55		125	0		70	°C

electrical characteristics over recommended operating free-air temperature range (unless otherwise noted)

PARAMETER	TEST CONDITIONS†	MIN	TYP‡	MAX	UNIT
V_{IH} High-level input voltage		2			V
V_{IL} Low-level input voltage				0.8	V
V_{IK} Input clamp voltage	$V_{CC} = \text{MIN}$, $I_I = -12 \text{ mA}$			-1.5	V
V_{OH} High-level output voltage	$V_{CC} = \text{MIN}$, $V_{IH} = 2 \text{ V}$, $V_{IL} = 0.8 \text{ V}$, $I_{OH} = \text{MAX}$	2.4	3.2		V
V_{OL} Low-level output voltage	$V_{CC} = \text{MIN}$, $V_{IH} = 2 \text{ V}$, $V_{IL} = 0.8 \text{ V}$, $I_{OL} = 16 \text{ mA}$		0.2	0.4	V
I_{OZ} Off-state (high-impedance-state) output current	$V_{CC} = \text{MAX}$, $V_{IH} = 2 \text{ V}$			40	μA
V_O Output clamp voltage	$V_{CC} = \text{MAX}$, $V_{IH} = 4.5 \text{ V}$			-1.5	V
				$V_{CC} + 1.5$	
I_I Input current at maximum input voltage	$V_{CC} = \text{MAX}$, $V_I = 5.5 \text{ V}$			1	mA
I_{IH} High-level input current	$V_{CC} = \text{MAX}$, $V_I = 2.4 \text{ V}$			40	μA
I_{IL} Low-level input current	$V_{CC} = \text{MAX}$, $V_I = 0.4 \text{ V}$			-1.6	mA
I_{OS} Short-circuit output current §	$V_{CC} = \text{MAX}$	-18		-55	mA
I_{CC} Supply current	$V_{CC} = \text{MAX}$, All inputs at 4.5 V, All outputs open		38	62	mA

†For conditions shown as MIN or MAX, use the appropriate value specified under recommended operating conditions for the applicable type.

‡All typical values are at $V_{CC} = 5 \text{ V}$, $T_A = 25^\circ\text{C}$.

§Not more than one output should be shorted at a time.

3

TTL DEVICES

TYPES SN54251, SN74251

DATA SELECTORS/MULTIPLEXERS WITH 3-STATE OUTPUTS

switching characteristics, $V_{CC} = 5\text{ V}$, $T_A = 25^\circ\text{C}$

PARAMETER [†]	FROM (INPUT)	TO (OUTPUT)	TEST CONDITIONS	MIN	TYP	MAX	UNIT
t_{PLH}	A, B, or C (4 levels)	Y	$C_L = 50\text{ pF}$, $R_L = 400\ \Omega$, See Note 2		29	45	ns
t_{PHL}					28	45	
t_{PLH}	A, B, or C (3 levels)	W			20	33	ns
t_{PHL}					21	33	
t_{PLH}	Any D	Y			17	28	ns
t_{PHL}					18	28	
t_{PLH}	Any D	W			10	15	ns
t_{PHL}					9	15	
t_{PZH}	$\bar{0}$	Y			17	27	ns
t_{PZL}					26	40	
t_{PZH}	$\bar{0}$	W			17	27	ns
t_{PZL}					24	40	
t_{PHZ}	$\bar{0}$	Y	$C_L = 5\text{ pF}$, $R_L = 400\ \Omega$, See Note 2		5	8	ns
t_{PLZ}					15	23	
t_{PHZ}	$\bar{0}$	W			5	8	ns
t_{PLZ}					15	23	

- [†] t_{PLH} = Propagation delay time, low-to-high-level output
- t_{PHL} = Propagation delay time, high-to-low-level output
- t_{PZH} = Output enable time to high level
- t_{PZL} = Output enable time to low level
- t_{PHZ} = Output disable time from high level
- t_{PLZ} = Output disable time from low level

NOTE 2: See General Information Section for load circuits and voltage waveforms.

3

TTL DEVICES

schematics of inputs and outputs

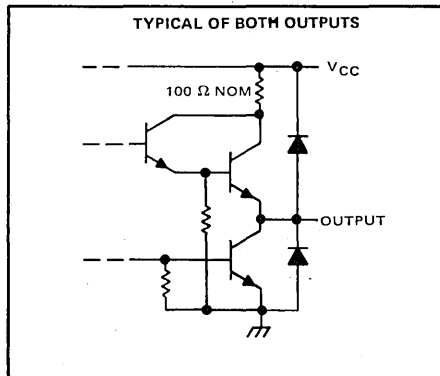
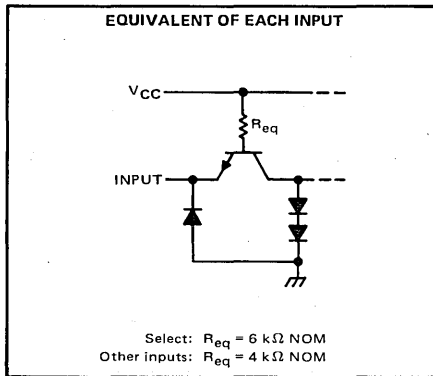

TYPES SN54LS251, SN74LS251 DATA SELECTORS/MULTIPLEXERS WITH 3-STATE OUTPUTS

absolute maximum ratings over operating free-air temperature range (unless otherwise noted)

Supply voltage, V_{CC} (see Note 1)	7 V
Input voltage	7 V
Off-state output voltage	5.5 V
Operating free-air temperature range: SN54LS251	55°C to 125°C
SN74LS251	0°C to 70°C
Storage temperature range	-65°C to 150°C

NOTE 1: Voltage values are with respect to network ground terminal.

recommended operating conditions

	SN54LS251			SN74LS251			UNIT
	MIN	NOM	MAX	MIN	NOM	MAX	
V_{CC} Supply voltage	4.5	5	5.5	4.75	5	5.25	V
V_{IH} High-level input voltage	2			2			V
V_{IL} Low-level input voltage	0.7			0.8			V
I_{OH} High-level output current	-1			-2.6			mA
I_{OL} Low-level output current	4			8			mA
T_A Operating free-air temperature	-55			125			°C

electrical characteristics over recommended operating free-air temperature range (unless otherwise noted)

PARAMETER	TEST CONDITIONS [†]	SN54LS251		SN74LS251		UNIT
		MIN	TYP ‡ MAX	MIN	TYP ‡ MAX	
V_{IK}	$V_{CC} = \text{MIN}$, $I_I = -18 \text{ mA}$	-1.5		-1.5		V
V_{OH}	$V_{CC} = \text{MIN}$, $V_{IH} = 2 \text{ V}$, $V_{IL} = \text{MAX}$ $I_{OH} = \text{MAX}$	2.4	3.4	2.4	3.1	V
V_{OL}	$V_{CC} = \text{MIN}$, $V_{IH} = 2 \text{ V}$, $V_{IL} = \text{MAX}$	$I_{OL} = 4 \text{ mA}$		0.25 0.4		V
		$I_{OL} = 8 \text{ mA}$		0.35 0.5		V
I_{OZ}	$V_{CC} = \text{MAX}$, $V_{IH} = 2 \text{ V}$	$V_O = 2.7 \text{ V}$		20		μA
		$V_O = 0.4 \text{ V}$		-20		μA
I_I	$V_{CC} = \text{MAX}$, $V_I = 7 \text{ V}$	0.1		0.1		mA
I_{IH}	$V_{CC} = \text{MAX}$, $V_I = 2.7 \text{ V}$	20		20		μA
I_{IL}	Enable G All other	$V_{CC} = \text{MAX}$, $V_I = 0.4$		-0.2		mA
				-0.4		mA
$I_{OS} §$	$V_{CC} = \text{MAX}$	-30	-130	-30	-130	mA
I_{CC}	$V_{CC} = \text{MAX}$, See Note 3	Condition A		6.1 10		mA
		Condition B		7.1 12		mA

† For conditions shown as MIN or MAX, use the appropriate value specified under recommended operating conditions for the applicable type.

‡ All typical values are at $V_{CC} = 5 \text{ V}$, $T_A = 25^\circ\text{C}$.

§ Not more than one output should be shorted at a time, and duration of the short-circuit should not exceed one second.

NOTE 3: I_{CC} is measured with the outputs open and all data and select inputs at 4.5 V under the following conditions:

- A. Enable grounded.
- B. Strobe at 4.5 V.

3
TTL DEVICES

TYPES SN54LS251, SN74LS251 (TIM9905)

DATA SELECTORS/MULTIPLEXERS WITH 3-STATE OUTPUTS

switching characteristics, $V_{CC} = 5\text{ V}$, $T_A = 25^\circ\text{C}$

PARAMETER†	FROM (INPUT)	TO (OUTPUT)	TEST CONDITIONS	MIN	TYP	MAX	UNIT
t_{PLH}	A, B, or C (4 levels)	Y	$C_L = 5\text{ pF}$, $R_L = 2\text{ k}\Omega$, See Note 2	29	45	ns	
t_{PHL}				28	45		
t_{PLH}	A, B, or C (3 levels)	W		20	33	ns	
t_{PHL}				21	33		
t_{PLH}	Any D	Y		17	28	ns	
t_{PHL}				18	28		
t_{PLH}	Any D	W		10	15	ns	
t_{PHL}				9	15		
t_{PZH}	\bar{G}	Y		30	45	ns	
t_{PZL}				26	40		
t_{PZH}	\bar{G}	W		17	27	ns	
t_{PZL}				24	40		
t_{PHZ}	\bar{G}	Y	$C_L = 15\text{ pF}$, $R_L = 2\text{ k}\Omega$, See Note 2	30	45	ns	
t_{PLZ}				15	25		
t_{PHZ}	\bar{G}	W		37	55	ns	
t_{PLZ}				15	25		

† t_{PLH} = Propagation delay time, low-to-high-level output
 t_{PHL} = Propagation delay time, low-to-high-level output
 t_{PZH} = Output enable time to high level
 t_{PZL} = Output enable time to low level
 t_{PHZ} = Output disable time from high level
 t_{PLZ} = Output disable time from low level

NOTE 2: See General Information Section for load circuits and voltage waveforms.

3

schematics of inputs and outputs

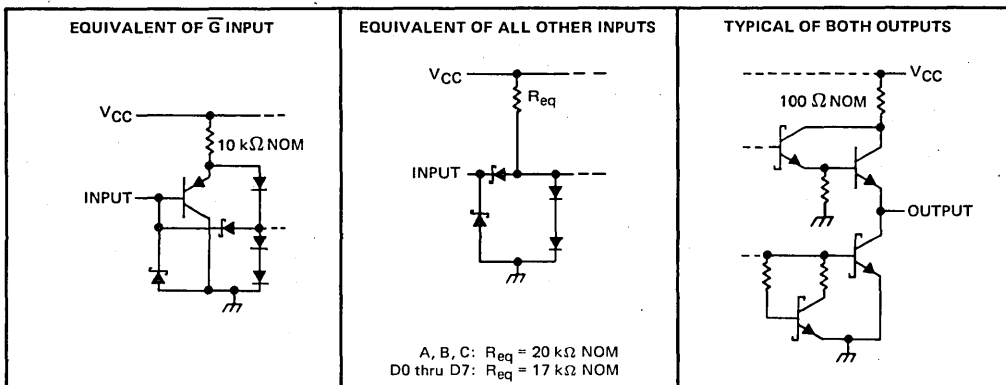

TYPES SN54S251, SN74S251 DATA SELECTORS/MULTIPLEXERS WITH 3-STATE OUTPUTS

absolute maximum ratings over operating free-air temperature range (unless otherwise noted)

Supply voltage, V_{CC} (see Note 1)	7 V
Input voltage	5.5 V
Off-state output voltage	5.5 V
Operating free-air temperature range: SN54S251	-55°C to 125°C
SN74S251	0°C to 70°C
Storage temperature range	-65°C to 150°C

NOTE 1: Voltage values are with respect to network ground terminal.

recommended operating conditions

	SN54S251			SN74S251			UNIT
	MIN	NOM	MAX	MIN	NOM	MAX	
Supply voltage, V_{CC}	4.5	5	5.5	4.75	5	5.25	V
High-level output current, I_{OH}			-2			-6.5	mA
Low-level output current, I_{OL}			20			20	mA
Operating free-air temperature, T_A	-55		125	0		70	°C

electrical characteristics over recommended operating free-air temperature range (unless otherwise noted)

PARAMETER	TEST CONDITIONS†	MIN	TYP‡	MAX	UNIT
V_{IH} High-level input voltage		2			V
V_{IL} Low-level input voltage				0.8	V
V_{IK} Input clamp voltage	$V_{CC} = \text{MIN}$, $I_I = -18 \text{ mA}$			-1.2	V
V_{OH} High-level output voltage	$V_{CC} = \text{MIN}$, $V_{IH} = 2 \text{ V}$, $V_{IL} = 0.8 \text{ V}$, $I_{OH} = \text{MAX}$	SN54S*	2.4	3.4	V
		SN74S*	2.4	3.2	
V_{OL} Low-level output voltage	$V_{CC} = \text{MIN}$, $V_{IH} = 2 \text{ V}$, $V_{IL} = 0.8 \text{ V}$, $I_{OL} = 20 \text{ mA}$			0.5	V
I_{OZ} Off-state (high-impedance-state) output current	$V_{CC} = \text{MAX}$, $V_{IH} = 2 \text{ V}$	$V_O = 2.4 \text{ V}$		50	μA
		$V_O = 0.5 \text{ V}$		-50	
I_I Input current at maximum input voltage	$V_{CC} = \text{MAX}$, $V_I = 5.5 \text{ V}$			1	mA
I_{IH} High-level input current	$V_{CC} = \text{MAX}$, $V_I = 2.7 \text{ V}$			50	μA
I_{IL} Low-level input current	$V_{CC} = \text{MAX}$, $V_I = 0.5 \text{ V}$			-2	mA
I_{OS} Short-circuit output current §	$V_{CC} = \text{MAX}$	-40		-100	mA
I_{CC} Supply current	$V_{CC} = \text{MAX}$, All inputs at 4.5 V, All outputs open		55	85	mA

† For conditions shown as MIN or MAX, use the appropriate value specified under recommended operating conditions for the applicable type.

‡ All typical values are at $V_{CC} = 5 \text{ V}$, $T_A = 25^\circ\text{C}$.

§ Not more than one output should be shorted at a time, and duration of the short-circuit should not exceed one second.

3
TTL DEVICES

TYPES SN54S251, SN74S251

DATA SELECTORS/MULTIPLEXERS WITH 3-STATE OUTPUTS

switching characteristics, $V_{CC} = 5\text{ V}$, $T_A = 25^\circ\text{C}$

PARAMETER [†]	FROM (INPUT)	TO (OUTPUT)	TEST CONDITIONS	MIN	TYP	MAX	UNIT
t_{PLH}	A, B, or C (4 levels)	Y	$C_L = 15\text{ pF}$, $R_L = 280\ \Omega$, See Note 2	12	18	ns	
t_{PHL}				13	19.5		
t_{PLH}	A, B, or C (3 levels)	W		10	15	ns	
t_{PHL}				9	13.5		
t_{PLH}	Any D	Y		8	12	ns	
t_{PHL}				8	12		
t_{PLH}	Any D	W		4.5	7	ns	
t_{PHL}				4.5	7		
t_{PZH}	\bar{G}	Y		$C_L = 50\text{ pF}$, $R_L = 280\ \Omega$, See Note 2	13	19.5	ns
t_{PZL}					14	21	
t_{PZH}	\bar{G}	W			13	19.5	ns
t_{PZL}					14	21	
t_{PHZ}	\bar{G}	Y	5.5		8.5	ns	
t_{PLZ}			9		14		
t_{PHZ}	\bar{G}	W	5.5	8.5	ns		
t_{PLZ}			9	14			

- [†] t_{PLH} = Propagation delay time, low-to-high-level output
 t_{PHL} = Propagation delay time, high-to-low-level output
 t_{PZH} = Output enable time to high level
 t_{PZL} = Output enable time to low level
 t_{PHZ} = Output disable time from high level
 t_{PLZ} = Output disable time from low level

NOTE 2: See General Information Section for load circuits and voltage waveforms.

3

TTL DEVICES

schematics of inputs and outputs

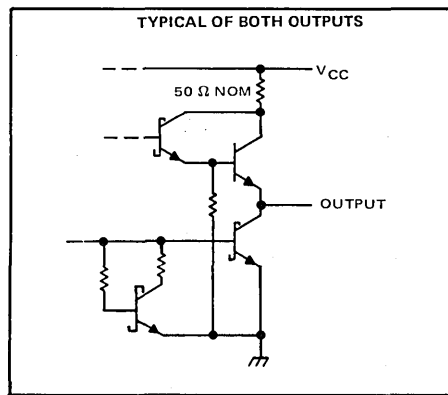
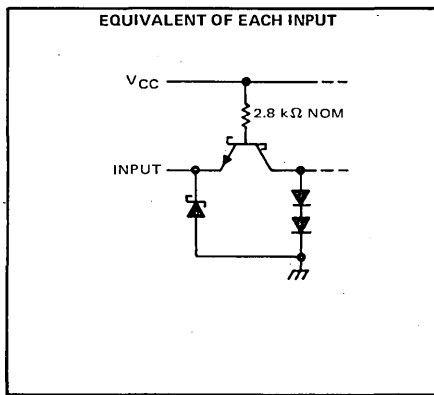

TYPES SN54LS253, SN54S253, SN74LS253, SN74S253 DUAL 4-LINE TO 1-LINE DATA SELECTORS/MULTIPLEXERS WITH 3-STATE OUTPUTS

SEPTEMBER 1972 — REVISED DECEMBER 1983

- Three-State Version of SN54/74LS153, SN54/74S153
- Schottky-Diode-Clamped Transistors
- Permits Multiplexing from N Lines to 1 Line
- Performs Parallel-to-Serial Conversion
- Fully Compatible with Most TTL Circuits
- Low Power Dissipation
 - 'LS253 . . . 35 mW Typical
 - 'S253 . . . 225 mW Typical

SN54LS253, SN54S253 . . . J OR W PACKAGE
SN74LS253, SN74S253 . . . D, J OR N PACKAGE

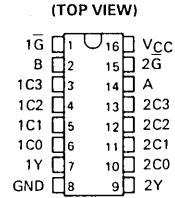

SN54LS253, SN54S253 . . . FK PACKAGE
SN74LS253, SN74S253 . . . FN PACKAGE

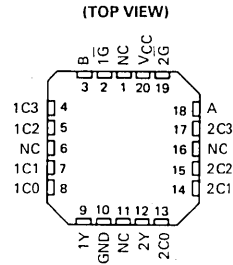

NC-No internal connection

description

Each of these Schottky-clamped data selectors/multiplexers contains inverters and drivers to supply fully complementary, on-chip, binary decoding data selection to the AND-OR gates. Separate output control inputs are provided for each of the two four-line sections.

The three-state outputs can interface with and drive data lines of bus-organized systems. With all but one of the common outputs disabled (at a high-impedance state) the low-impedance of the single enabled output will drive the bus line to a high or low logic level.

FUNCTION TABLE

SELECT INPUTS		DATA INPUTS				OUTPUT CONTROL	OUTPUT
B	A	C0	C1	C2	C3	\bar{G}	Y
X	X	X	X	X	X	H	Z
L	L	L	X	X	X	L	L
L	L	H	X	X	X	L	H
L	H	X	L	X	X	L	L
L	H	X	H	X	X	L	H
H	L	X	X	L	X	L	L
H	L	X	X	H	X	L	H
H	H	X	X	X	L	L	L
H	H	X	X	X	H	L	H

Address inputs A and B are common to both sections.

H = high level, L = low level, X = irrelevant, Z = high impedance (off)

absolute maximum ratings over operating free-air temperature range (unless otherwise noted)

Supply voltage, V_{CC} (see Note 1)	7 V
Input voltage: 'LS253	7 V
'S253	5.5 V
Off-state output voltage	5.5 V
Operating free-air temperature range: SN54LS253, SN54S253	- 55°C to 125°C
SN74LS253, SN74S253	0°C to 70°C
Storage temperature range	- 65°C to 150°C

NOTE 1: Voltage values are with respect to network ground terminal.

PRODUCTION DATA
This document contains information current as of publication date. Products conform to specifications per the terms of Texas Instruments standard warranty. Production processing does not necessarily include testing of all parameters.



POST OFFICE BOX 225012 • DALLAS, TEXAS 75265



**TYPES SN54LS253, SN54S253, SN74LS253, SN74S253
DUAL 4-LINE TO 1-LINE DATA SELECTORS/MULTIPLEXERS
WITH 3-STATE OUTPUTS**

logic diagram

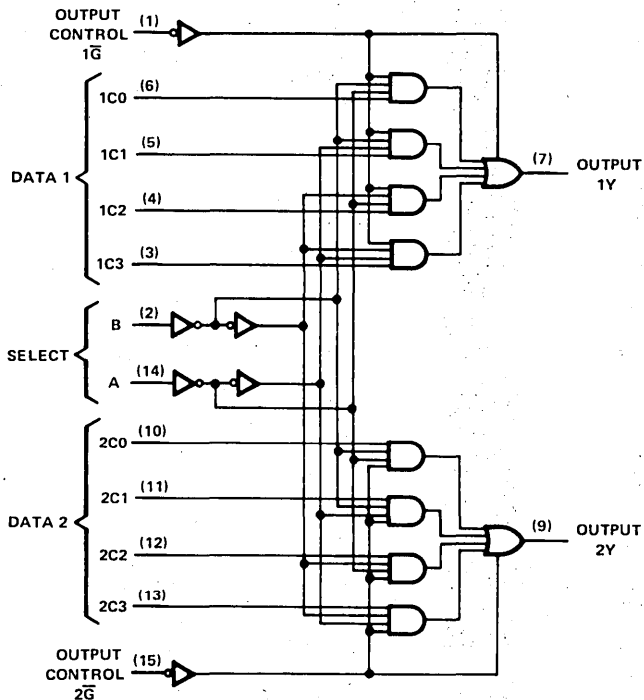

Pin numbers shown on logic notation are for D, J or N packages.

**TYPES SN54LS253, SN74LS253,
DUAL 4-LINE TO 1-LINE DATA SELECTORS/MULTIPLEXERS
WITH 3-STATE OUTPUTS**

schematic (each selector/multiplexer, and the common select section)

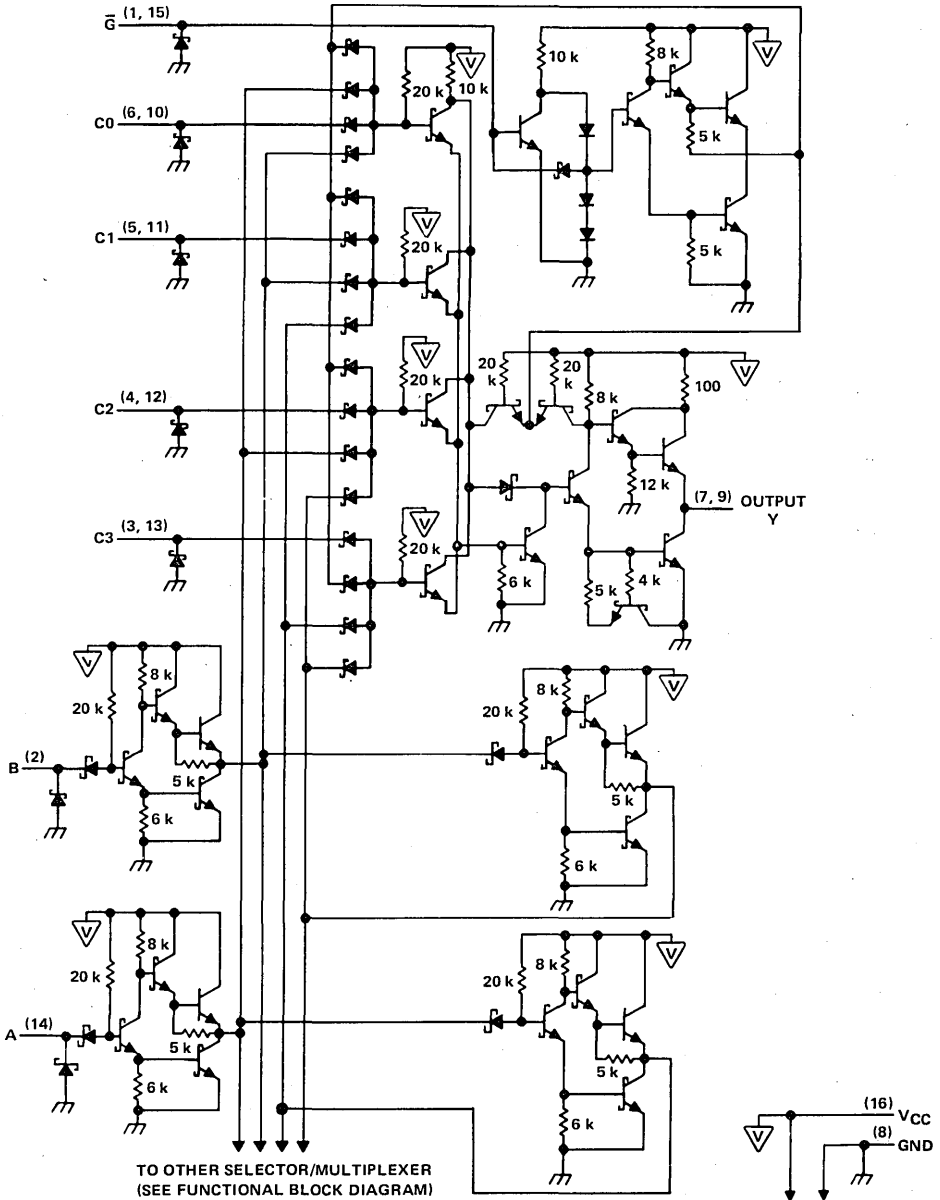

Pin numbers shown are for D, J or N packages.

3
TTL DEVICES

TYPES SN54LS253, SN74LS253

DUAL 4-LINE TO 1-LINE DATA SELECTORS/MULTIPLEXERS

WITH 3-STATE OUTPUTS

recommended operating conditions

	SN54LS253			SN74LS253			UNIT
	MIN	NOM	MAX	MIN	NOM	MAX	
V _{CC} Supply voltage	4.5	5	5.5	4.75	5	5.25	V
V _{IH} High-level input voltage	2			2			V
V _{IL} Low-level input voltage			0.7			0.8	V
I _{OH} High-level output current			-1			-2.6	mA
I _{OL} Low-level output current			4			8	mA
T _A Operating free-air temperature	-55		125	0		70	°C

electrical characteristics over recommended operating free-air temperature range (unless otherwise noted)

PARAMETER	TEST CONDITIONS†	SN54LS253		SN74LS253		UNIT	
		MIN	TYP‡ MAX	MIN	TYP‡ MAX		
V _{IK}	V _{CC} = MIN, I _I = -18 mA		-1.5		-1.5	V	
V _{OH}	V _{CC} = MIN, V _{IH} = 2 V, V _{IL} = MAX, I _{OH} = MAX	2.4	3.4	2.4	3.1	V	
V _{OL}	V _{CC} = MIN, V _{IH} = 2 V, V _{IL} = MAX	I _{OL} = 4 mA	0.25	0.4	0.25	0.4	V
		I _{OL} = 8 mA			0.25	0.5	
I _{OZ}	V _{CC} = MAX, V _{IH} = 2 V	V _O = 2.7 V				20	μA
		V _O = 0.4 V				-20	
I _I	V _{CC} = MAX, V _I = 7 V		0.1		0.1	mA	
I _{IH}	V _{CC} = MAX, V _I = 2.7 V		20		20	μA	
I _{IL}	V _{CC} = MAX, V _I = 0.4 V	\bar{G}				-0.2	mA
		All other				-0.4	
I _{O5} §	V _{CC} = MAX	-30	-130	-30	-130	mA	
I _{CC}	V _{CC} = MAX, See Note 2	Condition A	7	12	7	12	mA
		Condition B	8.5	14	8.5	14	

† For conditions shown as MIN or MAX, use the appropriate value specified under recommended operating conditions.

‡ All typical values are at V_{CC} = 5 V, T_A = 25°C.

§ Not more than one output should be shorted at a time, and duration for the short-circuit should exceed one second.

NOTE 2: I_{CC} is measured with the outputs open under the following conditions:

A. All inputs grounded.

B. Output control at 4.5 V, all inputs grounded.

switching characteristics, V_{CC} = 5 V, T_A = 25°C

PARAMETER	FROM (INPUT)	TO (OUTPUT)	TEST CONDITIONS	MIN	TYP	MAX	UNIT
t _{PLH}	Data	Y	C _L = 15 pF, R _L = 2 kΩ, See Note 3		17	25	ns
t _{PHL}					13	20	
t _{PLH}	Select	Y			30	45	ns
t _{PHL}					21	32	
t _{PZH}	Output Control	Y			15	28	ns
t _{PZL}					15	23	
t _{PHZ}	Output Control	Y	C _L = 5 pF, R _L = 2 kΩ, See Note 3		27	41	ns
t _{PLZ}					18	27	

NOTE 3: See General Information Section for load circuits and voltage waveforms.

3

TTL DEVICES

TYPES SN54S253, SN74S253 DUAL 4-LINE TO 1-LINE DATA SELECTORS/MULTIPLEXERS WITH 3-STATE OUTPUTS

recommended operating conditions

	SN54S253			SN74S253			UNIT
	MIN	NOM	MAX	MIN	NOM	MAX	
V _{CC} Supply voltage	4.5	5	5.5	4.75	5	5.25	V
V _{IH} High-level input voltage	2			2			V
V _{IL} Low-level input voltage	0.8			0.8			V
I _{OH} High-level output current	-2			-6.5			mA
I _{OL} Low-level output current	20			20			mA
T _A Operating free-air temperature	-55	125		0	70		°C

electrical characteristics over recommended operating free-air temperature range (unless otherwise noted)

PARAMETER	TEST CONDITIONS†				MIN	TYP‡	MAX	UNIT
V _{IK}	V _{CC} = MIN, I _I = -18 mA				-1.2			V
V _{OH}	V _{CC} = MIN, V _{IH} = 2 V, V _{IL} = 0.8 V, I _{OH} = MAX	Series 54S		2.5	3.4			V
		Series 74S		2.7	3.4			
V _{OL}	V _{CC} = MIN, V _{IH} = 2 V, V _{IL} = 0.8 V, I _{OL} = 20 mA				0.5			V
I _{OZ}	V _{CC} = MAX, V _{IH} = 2 V				50			μA
					-50			
I _I	V _{CC} = MAX, V _I = 5.5 V				1			mA
I _{IH}	V _{CC} = MAX, V _I = 2.7 V				50			μA
I _{IL}	V _{CC} = MAX, V _I = 0.5 V				-2			mA
					-0.25			
I _{OS} §	V _{CC} = MAX				-40			mA
I _{CC}	V _{CC} = MAX, See Note 2				45		70	mA
					65		85	

† For conditions shown as MIN or MAX, use the appropriate value specified under recommended operating conditions.

‡ All typical values are at V_{CC} = 5 V, T_A = 25°C.

§ Not more than one output should be shorted at a time and duration of short-circuit should not exceed one second.

NOTE 2: I_{CC} is measured with the outputs open under the following conditions:

- A. All inputs grounded.
- B. Output control at 4.5 V, all inputs grounded.

switching characteristics, V_{CC} = 5 V, T_A = 25°C

PARAMETER	FROM (INPUT)	TO (OUTPUT)	TEST CONDITIONS		MIN	TYP	MAX	UNIT
t _{PLH}	Data	Y	R _L = 280 Ω, See Note 3	C _L = 15 pF	6	9	ns	
t _{PHL}					6	9		
t _{PLH}	Select	Y			11.5	18	ns	
t _{PHL}					12	18		
t _{PZH}	Output	Y			11	16.5	ns	
t _{PZL}	Control				12	18		
t _{PHZ}	Output	Y	R _L = 280 Ω, See Note 3	C _L = 5 pF	6.5	9.5	ns	
t _{PLZ}					Control	10		

NOTE 3: See General Information Section for load circuits and voltage waveforms.

3
TTL DEVICES

TYPES SN54LS257B, SN54LS258B, SN54S257, SN54S258, SN74LS257B, SN74LS258B, SN74S257, SN74S258 QUADRUPLE 2-LINE TO 1-LINE DATA SELECTORS/MULTIPLEXERS

OCTOBER 1976—REVISED DECEMBER 1983

- Three-State Outputs Interface Directly with System Bus
- 'LS257B and 'LS258B Offer Three Times the Sink-Current Capability of the Original 'LS257 and 'LS258
- Same Pin Assignments as SN54LS157, SN74LS157, SN54S157, SN74S157, and SN54LS158, SN74LS158, SN54S158, SN74S158
- Provides Bus Interface from Multiple Sources in High-Performance Systems

SN54LS257B, SN54S257,
SN54LS258B, SN54S258 . . . J OR W PACKAGE
SN74LS257B, SN74S257,
SN74LS258B, SN74S258 . . . D, J OR N PACKAGE
(TOP VIEW)

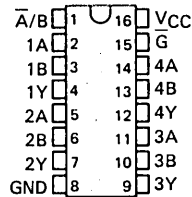

SN54LS257B, SN54S257,
SN54LS258B, SN54S258 . . . FK PACKAGE
SN74LS257B, SN74S257,
SN74LS258B, SN74S258 . . . FN PACKAGE
(TOP VIEW)

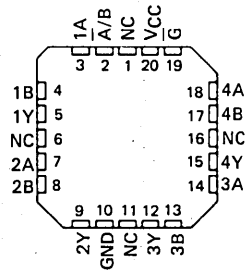

NC—No internal connection.

	AVERAGE PROPAGATION DELAY FROM DATA INPUT	TYPICAL POWER DISSIPATION†
'LS257B	9 ns	55 mW
'LS258B	9 ns	55 mW
'S257	4.8 ns	320 mW
'S258	4 ns	280 mW

† Off state (worst case)

description

These devices are designed to multiplex signals from four-bit data sources to four-output data lines in bus-organized systems. The 3-state outputs will not load the data lines when the output control pin (\bar{G}) is at a high-logic level.

Series 54LS and 54S are characterized for operation over the full military temperature range of -55°C to 125°C ; Series 74LS and 74S are characterized for operation from 0°C to 70°C .

FUNCTION TABLE

OUTPUT CONTROL	INPUTS		OUTPUT Y		
	SELECT	A	B	'LS257B 'S257	'LS258B 'S258
H	X	X	X	Z	Z
L	L	L	X	L	H
L	L	H	X	H	L
L	H	X	L	L	H
L	H	X	H	H	L

H = high level, L = low level, X = irrelevant,
Z = high impedance (off)

PRODUCTION DATA
This document contains information current as of publication date. Products conform to specifications per the terms of Texas Instruments standard warranty. Production processing does not necessarily include testing of all parameters.

**TEXAS
INSTRUMENTS**

POST OFFICE BOX 225012 • DALLAS, TEXAS 75265

**TYPES SN54LS257B, SN54LS258B, SN54S257, SN54S258,
SN74LS257B, SN74LS258B, SN74S257, SN74S258
QUADRUPLE 2-LINE TO 1-LINE DATA SELECTORS/MULTIPLEXERS**

logic diagrams

'LS257B, 'S257

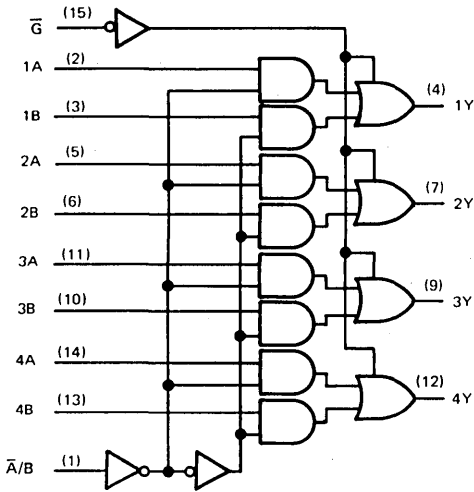

'LS258B, 'S258

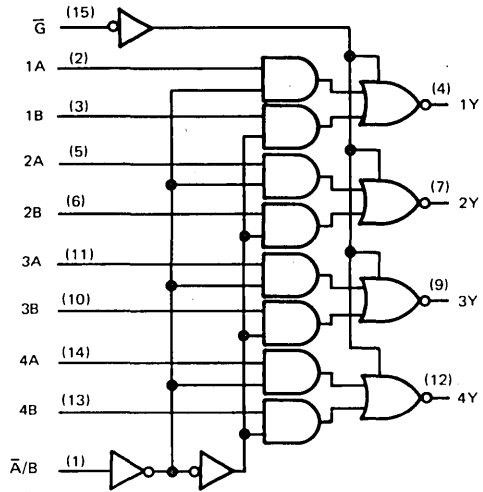

logic symbol

'LS257B

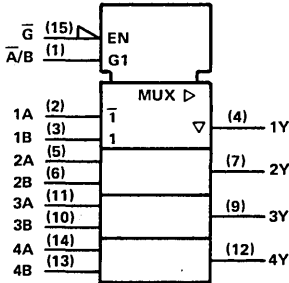

'LS258B

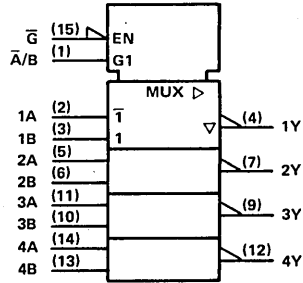

'S257

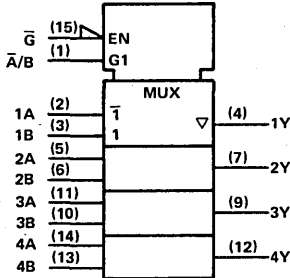

'S258

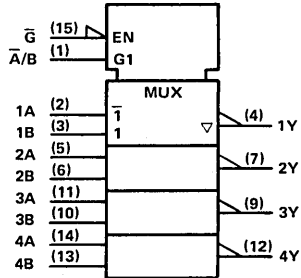

Pin numbers shown on logic notation are for D, J or N packages.

**TYPES SN54LS257B, SN54LS258B, SN54S257, SN54S258,
SN74LS257B, SN74LS258B, SN74S257, SN74S258
QUADRUPLE 2-LINE TO 1-LINE DATA SELECTORS/MULTIPLEXERS**

schematics of inputs and outputs

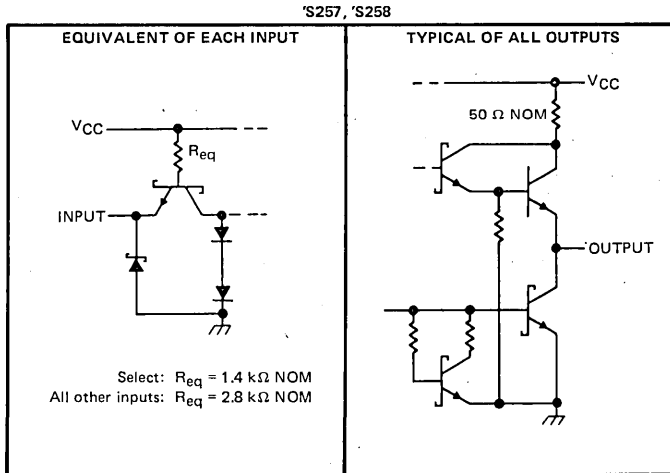
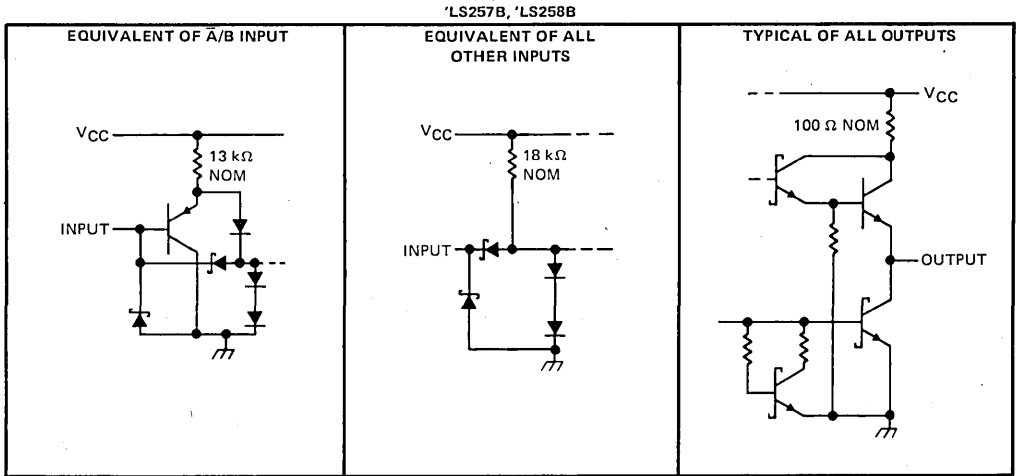

absolute maximum ratings over operating free-air temperature range (unless otherwise noted)

Supply voltage, V_{CC} (see Note 1)	7 V
Input voltage: 'LS257B, 'LS258B Circuits	7 V
'S257, 'S258 Circuits	5.5 V
Off-state output voltage	5.5 V
Operating free-air temperature range: SN54LS', SN54S' Circuits	-55°C to 125°C
SN74LS', SN74S' Circuits	0°C to 70°C
Storage temperature range	-65°C to 150°C

NOTE 1: Voltage values are with respect to network ground terminal.

3
TTL DEVICES

TYPES SN54LS257B, SN54LS258B, SN74LS257B, SN74LS258B QUADRUPLE 2-LINE TO 1-LINE DATA SELECTORS/MULTIPLEXERS

recommended operating conditions

	SN54LS'			SN74LS'			UNIT
	MIN	NOM	MAX	MIN	NOM	MAX	
V _{CC} Supply voltage	4.5	5	5.5	4.75	5	5.25	V
V _{IH} High-level input voltage	2			2			V
V _{IL} Low-level input voltage				0.8			V
I _{OH} High-level output current	-1			-2.6			mA
I _{OL} Low-level output current				24			mA
T _A Operating free-air temperature	-55			125			°C

electrical characteristics over recommended operating free-air temperature range (unless otherwise noted)

PARAMETER	TEST CONDITIONS†		SN54LS'			SN74LS'			UNIT	
			MIN	TYP‡	MAX	MIN	TYP‡	MAX		
V _{IK}	V _{CC} = MIN, I _I = -18 mA		-1.5			-1.5			V	
V _{OH}	V _{CC} = MIN, I _{OH} = MAX, V _{IH} = 2 V, V _{IL} = MAX		2.4	3.4		2.4	3.1		V	
V _{OL}	V _{CC} = MIN, V _{IH} = 2 V, V _{IL} = MAX, I _{OL} = 12 mA		0.25			0.25			V	
	I _{OL} = 24 mA					0.35				
I _{OZH}	V _{CC} = MAX, V _{IH} = 2 V, V _O = 2.7 V		20			20			μA	
I _{OZL}	V _{CC} = MAX, V _{IH} = 2 V, V _O = 0.4 V		-20			-20			μA	
I _I	V _{CC} = MAX, V _I = 7 V		0.1			0.1			mA	
I _{IH}	V _{CC} = MAX, V _I = 2.7 V		20			20			μA	
I _{IL}	V _{CC} = MAX, V _I = 0.4 V		-0.4			-0.4			mA	
I _{OS} §	V _{CC} = MAX,		-30	-130		-30	-130		mA	
I _{CC}	All outputs high	V _{CC} = MAX, See Note 2	'LS257B	8		8		12		mA
	All outputs low			12		12		18		
	All outputs off			13		13		19		
	All outputs high			6		6		9		
	All outputs low			10		10		15		
	All outputs off			11		11		16		

† For conditions shown as MIN or MAX, use the appropriate value specified under recommended operating conditions.

‡ All typical values are at V_{CC} = 5 V, T_A = 25°C.

§ Not more than one output should be shorted at a time and duration of the short-circuit should not exceed one second.

NOTE 2: I_{CC} is measured with all outputs open and all possible inputs grounded while achieving the stated output conditions.

switching characteristics, V_{CC} = 5 V, T_A = 25°C, R_L = 667 Ω

PARAMETER	FROM (INPUT)	TO (OUTPUT)	TEST CONDITIONS		'LS257B			'LS258B			UNIT
					MIN	TYP	MAX	MIN	TYP	MAX	
t _{PLH}	Data	Any	C _L = 45 pF, See Note 3	8		7		12		ns	
t _{PHL}				10		11		17			
t _{PLH}	Select	Any		16		14		21		ns	
t _{PHL}				17		19		24			
t _{PZH}	Output Control	Any		15		15		30		ns	
t _{PZL}				19		20		30			
t _{PHZ}	Output Control	Any	18		18		30		ns		
t _{PLZ}			16		16		25				

t_{PLH} = propagation delay time, low-to-high-level output

t_{PHL} = propagation delay time, high-to-low-level output

t_{PZH} = output enable time to high level

NOTE 3: See General Information Section for load circuits and voltage waveforms.

t_{PZL} = output enable time to low level

t_{PHZ} = output disable time from high level

t_{PLZ} = output disable time from low level

TYPES SN54S257, SN54S258, SN74S257, SN74S258 QUADRUPLE 2-LINE TO 1-LINE DATA SELECTORS/MULTIPLEXERS

recommended operating conditions

	SN54S'			SN74S'			UNIT
	MIN	NOM	MAX	MIN	NOM	MAX	
Supply voltage, V_{CC}	4.5	5	5.5	4.75	5	5.25	V
High-level output current, I_{OH}			-2			-6.5	mA
Low-level output current, I_{OL}			20			20	mA
Operating free-air temperature, T_A	-55		125	0		70	°C

electrical characteristics over recommended operating free-air temperature range (unless otherwise noted)

PARAMETER	TEST CONDITIONS†	'S257			'S258			UNIT
		MIN	TYP‡	MAX	MIN	TYP‡	MAX	
V_{IH} High-level input voltage		2			2			V
V_{IL} Low-level input voltage				0.8			0.8	V
V_{IK} Input clamp voltage	$V_{CC} = \text{MIN}, I_I = -18 \text{ mA}$			-1.2			-1.2	V
V_{OH} High-level output voltage	$V_{CC} = \text{MIN}, V_{IH} = 2 \text{ V},$ $V_{IL} = 0.8 \text{ V}, I_{OH} = -1 \text{ mA}$	SN74S'	2.7		2.7			V
	$V_{CC} = \text{MIN}, V_{IH} = 2 \text{ V},$ $V_{IL} = 0.8 \text{ V}, I_{OH} = \text{MAX}$	SN54S'	2.4	3.4	2.4	3.4		
		SN74S'	2.4	3.2	2.4	3.2		
V_{OL} Low-level output voltage	$V_{CC} = \text{MIN}, V_{IH} = 2 \text{ V},$ $V_{IL} = 0.8 \text{ V}, I_{OL} = 20 \text{ mA}$			0.5		0.5		V
I_{OZH} Off-state output current, high-level voltage applied	$V_{CC} = \text{MAX}, V_{IH} = 2 \text{ V},$ $V_O = 2.4 \text{ V}$			50		50		μA
I_{OZL} Off-state output current, low-level voltage applied	$V_{CC} = \text{MAX}, V_{IH} = 2 \text{ V},$ $V_O = 0.5 \text{ V}$			-50		-50		μA
I_I Input current at maximum input voltage	$V_{CC} = \text{MAX}, V_I = 5.5 \text{ V}$			1		1		mA
I_{IH} High-level input current	S input			100		100		μA
	Any other	$V_{CC} = \text{MAX}, V_I = 2.7 \text{ V}$		50		50		
I_{IL} Low-level input current	S input			-4		-4		mA
	Any other	$V_{CC} = \text{MAX}, V_I = 0.5 \text{ V}$		-2		-2		
I_{OS} Short-circuit output current‡	$V_{CC} = \text{MAX}$			-40		-100		mA
I_{CC} Supply current	All outputs high			44		68		mA
	All outputs low	$V_{CC} = \text{MAX},$ See Note 2		60		93		
	All outputs off			64		99		

† For conditions shown as MIN or MAX, use the appropriate value specified under recommended operating conditions.

‡ All typical values are at $V_{CC} = 5 \text{ V}, T_A = 25^\circ\text{C}$.

§ Not more than one output should be shorted at a time and duration of the short-circuit should not exceed one second.

NOTE 2: I_{CC} is measured with all outputs open and all possible inputs grounded while achieving the stated output conditions.

switching characteristics, $V_{CC} = 5 \text{ V}, T_A = 25^\circ\text{C}, R_L = 280 \Omega$

PARAMETER¶	FROM (INPUT)	TO (OUTPUT)	TEST CONDITIONS	'S257			'S258			UNIT
				MIN	TYP	MAX	MIN	TYP	MAX	
t_{PLH}	Data	Any	$C_L = 15 \text{ pF},$ See Note 3	5	7.5		4	6	ns	
t_{PHL}				4.5	6.5		4	6		
t_{PLH}	Select	Any		8.5	15		8	12	ns	
t_{PHL}				8.5	15		7.5	12		
t_{PZH}	Output Control	Any		13	19.5		13	19.5	ns	
t_{PZL}				14	21		14	21		
t_{PHZ}	Output Control	Any	$C_L = 5 \text{ pF},$ See Note 3	5.5	8.5		5.5	8.5	ns	
t_{PLZ}			9	14		9	14			

¶ f_{max} = Maximum clock frequency

t_{PLH} = propagation delay time, low-to-high-level output

t_{PHL} = propagation delay time, high-to-low-level output

t_{PZH} = output enable time to high level

t_{PZL} = output enable time to low level

t_{PHZ} = output disable time from high level

t_{PLZ} = output disable time from low level

NOTE 3: See General Information Section for load circuits and voltage waveforms.



TTL DEVICES

TYPES SN54259, SN54LS259B, SN74259, SN74LS259B 8-BIT ADDRESSABLE LATCHES

REVISED DECEMBER 1983

- 8-Bit Parallel-Out Storage Register Performs Serial-to-Parallel Conversion with Storage
- Asynchronous Parallel Clear
- Active High Decoder
- Enable/Disable Input Simplifies Expansion
- Expandable for N-Bit Applications
- Four Distinct Functional Modes
- Package Options Include Both Plastic and Ceramic Chip Carriers in Addition to Plastic and Ceramic DIPS
- Dependable Texas Instruments Quality and Reliability

description

These 8-bit addressable latches are designed for general purpose storage applications in digital systems. Specific uses include working registers, serial-holding registers, and active-high decoders or demultiplexers. They are multifunctional devices capable of storing single-line data in eight addressable latches, and being a 1-of-8 decoder or demultiplexer with active-high outputs.

Four distinct modes of operation are selectable by controlling the clear (CLR) and enable (G) inputs as enumerated in the function table. In the addressable-latch mode, data at the data-in terminal is written into the addressed latch. The addressed latch will follow the data input with all unaddressed latches remaining in their previous states. In the memory mode, all latches remain in their previous states and are unaffected by the data or address inputs. To eliminate the possibility of entering erroneous data in the latches, enable G should be held high (inactive) while the address lines are changing. In the 1-of-8 decoding or demultiplexing mode, the addressed output will follow the level of the D input with all other outputs low. In the clear mode, all outputs are low and unaffected by the address and data inputs.

The SN54259 and SN54LS259B are characterized for operation over the full military temperature range of -55°C to 125°C. The SN74259 and SN74LS259B are characterized for operation from 0°C to 70°C.

SN54259, SN54LS259B ... J OR W PACKAGE
SN74259 ... J OR N PACKAGE
SN74LS259B ... D, J OR N PACKAGE
(TOP VIEW)

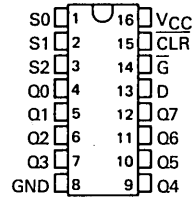

SN54LS259B ... FK PACKAGE
SN74LS259B ... FN PACKAGE
(TOP VIEW)

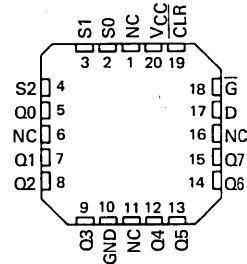

NC - No internal connection

logic symbol

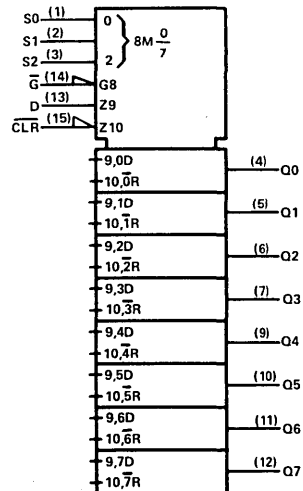

Pin numbers shown on logic notation are for D, J or N packages.

PRODUCTION DATA
This document contains information current as of publication date. Products conform to specifications per the terms of Texas Instruments standard warranty. Production processing does not necessarily include testing of all parameters.

**TEXAS
INSTRUMENTS**

POST OFFICE BOX 225012 • DALLAS, TEXAS 75265

TTL DEVICES

3-863

TYPES SN54259, SN54LS259B, SN74259, SN74LS259B

8-BIT ADDRESSABLE LATCHES

FUNCTION TABLE

INPUTS		OUTPUT OF ADDRESSED LATCH	EACH OTHER OUTPUT	FUNCTION
CLR	\bar{G}			
H	L	D	Q_{i0}	Addressable Latch
H	H	Q_{i0}	Q_{i0}	Memory
L	L	D	L	8-Line Demultiplexer
L	H	L	L	Clear

H \equiv high level, L \equiv low level
 D \equiv the level at the data input
 Q_{i0} \equiv the level of Q_i ($i = 0, 1, \dots, 7$, as appropriate) before the indicated steady-state input conditions were established.

LATCH SELECTION TABLE

SELECT INPUTS			LATCH
S2	S1	S0	ADDRESSED
L	L	L	0
L	L	H	1
L	H	L	2
L	H	H	3
H	L	L	4
H	L	H	5
H	H	L	6
H	H	H	7

schematic of inputs and outputs

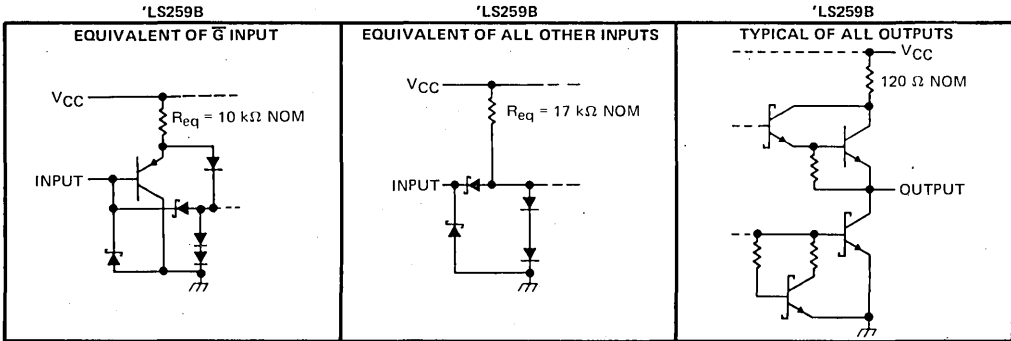
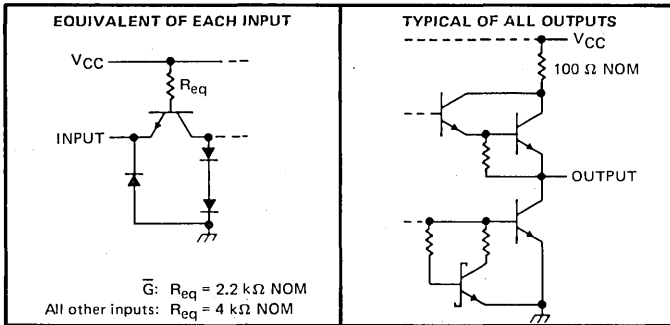

absolute maximum ratings over operating free-air temperature range (unless otherwise noted)

Supply voltage (see Note 1)	7 V
Input voltage: SN54259, SN74259	5.5 V
SN54LS259B, SN74LS259B	7 V
Operating free-air temperature range: SN54259, SN54LS259B	-55°C to 125°C
SN74259, SN74LS259B	0°C to 70°C
Storage temperature range	-65°C to 150°C

NOTE 1: Voltage values are with respect to network ground terminal.

3

TTL DEVICES

TYPES SN54259, SN74259 8-BIT ADDRESSABLE LATCHES

recommended operating conditions

	SN54259			SN74259			UNIT
	MIN	NOM	MAX	MIN	NOM	MAX	
Supply voltage, V_{CC}	4.5	5	5.5	4.75	5	5.25	V
High-level output current, I_{OH}	-800			-800			μ A
Low-level output current, I_{OL}	16			16			mA
Width of clear or enable pulse, t_w	15			15			ns
Setup time, t_{su}	Data	15†		15†		ns	
	Address	5†		5†			
Hold time, t_h	Data	0†		0†		ns	
	Address	20†		20†			
Operating free-air temperature, T_A	-55		125	0		70	°C

† The arrow indicates that the rising edge of the enable pulse is used for reference.

electrical characteristics over recommended operating free-air temperature range (unless otherwise noted)

PARAMETER	TEST CONDITIONS†	SN54259		SN74259		UNIT
		MIN	TYP‡	MAX	MIN	
V_{IH} High-level input voltage		2		2		V
V_{IL} Low-level input voltage		0.8		0.8		V
V_{IK} Input clamp voltage	$V_{CC} = \text{MIN}, I_I = 12 \text{ mA}$	-1.5		-1.5		V
V_{OH} High-level output voltage	$V_{CC} = \text{MIN}, V_{IH} = 2 \text{ V}, V_{IL} = 0.8 \text{ V}, I_{OH} = -800 \mu\text{A}$	2.4	3.4	2.4	3.4	V
V_{OL} Low-level output voltage	$V_{CC} = \text{MIN}, V_{IH} = 2 \text{ V}, V_{IL} = 0.8 \text{ V}, I_{OL} = 16 \text{ mA}$	0.2	0.4	0.2	0.4	V
I_I Input current at maximum input voltage	$V_{CC} = \text{MAX}, V_I = 5.5 \text{ V}$	1		1		mA
I_{IH} High-level input current	\bar{G}	80		80		μ A
	Other inputs	40		40		
I_{IL} Low-level input current	\bar{G}	-3.2		-3.2		mA
	Other inputs	-1.6		-1.6		
I_{OS} Short-circuit output current§	$V_{CC} = \text{MAX}$	-18	-57	-18	-57	mA
I_{CC} Supply current	$V_{CC} = \text{MAX}, \text{ See Note 2}$	60	90	60	90	mA

† For conditions shown as MIN or MAX, use the appropriate value specified under recommended operating conditions.

‡ All typical values are at $V_{CC} = 5 \text{ V}, T_A = 25^\circ \text{C}$.

§ Not more than one output should be shorted at a time.

NOTE 2: I_{CC} is measured with the inputs grounded and the outputs open.

switching characteristics, $V_{CC} = 5 \text{ V}, T_A = 25^\circ \text{C}$

PARAMETER	FROM (INPUT)	TO (OUTPUT)	TEST CONDITIONS	MIN	TYP	MAX	UNIT
t_{PHL}	CLR	Any Q	$C_L = 15 \text{ pF}, R_L = 400 \Omega, \text{ See Note 3}$		16	25	ns
t_{PLH}	Data	Any Q			14	24	ns
t_{PHL}					11	20	
t_{PLH}	Address	Any Q			15	28	ns
t_{PHL}					17	28	
t_{PLH}	\bar{G}	Any Q			12	20	ns
t_{PHL}					11	20	

t_{PLH} = propagation delay time, low-to-high-level output

t_{PHL} = propagation delay time, high-to-low-level output

NOTE 3: See General Information Section for load circuits and voltage waveforms.

TEXAS
INSTRUMENTS

POST OFFICE BOX 225012 • DALLAS, TEXAS 75265

TTL DEVICES

TYPES SN54LS259B, SN74LS259B 8-BIT ADDRESSABLE LATCHES

recommended operating conditions

		SN54LS259B			SN74LS259B			UNIT
		MIN	NOM	MAX	MIN	NOM	MAX	
V _{CC}	Supply voltage	4.5	5	5.5	4.75	5	5.25	V
V _{IH}	High-level input voltage	2			2			V
V _{IL}	Low-level input voltage	0.7			0.8			V
I _{OH}	High-level output current	-0.4			-0.4			mA
I _{OL}	Low-level output current	4			8			mA
t _w	Pulse duration	\bar{G} low	17		17		ns	
		CLR low	10		10			
t _{su}	Set up time	Data before \bar{G} ↑	20		20		ns	
		Address before \bar{G} ↑	17		17			
		Address before \bar{G} ↓	0		0			
t _h	Hold time	Data after \bar{G} ↑	0		0		ns	
		Address after \bar{G} ↑	0		0			
T _A	Operating free-air temperature	-55	125		0	70		°C

electrical characteristics over recommended operating free-air temperature range (unless otherwise noted)

PARAMETER	TEST CONDITIONS†	SN54LS259B			SN74LS259B			UNIT
		MIN	TYP	MAX	MIN	TYP	MAX	
V _{IK}	V _{CC} = MIN, I _I = -18 mA	-1.5			-1.5			V
V _{OH}	V _{CC} = MIN, V _{IH} = 2 V, V _{IL} = MAX, I _{OH} = -0.4 mA	2.5	3.4		2.7	3.4		V
V _{OL}	V _{CC} = MIN, V _{IH} = 2 V, V _{IL} = MAX, I _{OL} = 4 mA	0.25	0.4		0.25	0.4		V
					0.35	0.5		
I _I	V _{CC} = MAX, V _I = 7 V	0.1			0.1			mA
I _{IH}	V _{CC} = MAX, V _I = 2.7 V	20			20			μA
I _{IL}	V _{CC} = MAX, V _I = 0.4 V	-0.4			-0.4			mA
I _{OS} §	V _{CC} = MAX	-20	-100		-20	-100		mA
I _{CC}	V _{CC} = MAX, See Note 2	27	36		22	36		mA

† For conditions shown as MIN or MAX, use the appropriate value specified under recommended operating conditions

‡ All typical values are at V_{CC} = 5 V, T_A = 25°C.

§ Not more than one output should be shorted at a time, and duration short-circuit should not exceed one second.

NOTE 2: I_{CC} is measured with the inputs grounded and the outputs open.

switching characteristics, V_{CC} = 5 V, T_A = 25°C

PARAMETER	FROM (INPUT)	TO (OUTPUT)	TEST CONDITIONS	MIN	TYP	MAX	UNIT
t _{PHL}	CLR	Any Q	C _L = 15 pF, R _L = 2 kΩ, See Note 3		12	18	ns
t _{PLH}	Data	Any Q			19	30	ns
t _{PHL}					13	20	
t _{PLH}	Address	Any Q			17	27	ns
t _{PHL}					14	20	
t _{PLH}	\bar{G}	Any Q			15	24	ns
t _{PHL}					15	24	

t_{PLH} = propagation delay time, low-to-high level output

t_{PHL} = propagation delay time, high-to-low level output

NOTE 3: See General Information Section for load circuits and voltage waveforms.

TYPES SN54S260, SN74S260 DUAL 5-INPUT POSITIVE -NOR GATES

REVISED DECEMBER 1983

- Package Options Include Both Plastic and Ceramic Chip Carriers in Addition to Plastic and Ceramic DIPs
- Dependable Texas Instruments Quality and Reliability

description

These devices contain two independent 5-input positive -NOR gates. They perform the Boolean function $Y = \overline{A+B+C+D+E}$ in positive logic.

The SN54S260 is characterized for operation over the full military temperature range of -55°C to 125°C . The SN74S260 is characterized for operation from 0°C to 70°C .

logic diagram (each gate)

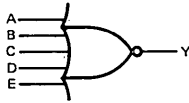

SN54S260 ... J OR W PACKAGE
SN74S260 ... D, J OR N PACKAGE
(TOP VIEW)

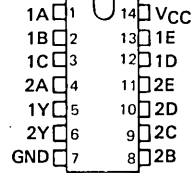

SN54S260 ... FK PACKAGE
SN74S260 ... FN PACKAGE
(TOP VIEW)

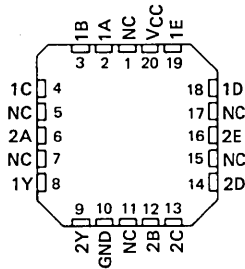

NC - No internal connection

PRODUCTION DATA
This document contains information current as of publication date. Products conform to specifications per the terms of Texas Instruments standard warranty. Production processing does not necessarily include testing of all parameters.

TEXAS
INSTRUMENTS

POST OFFICE BOX 225012 • DALLAS, TEXAS 75265

TTL DEVICES

3-867

TYPES SN54S260, SN74S260 DUAL 5-INPUT POSITIVE -NOR GATES

schematic (each gate)

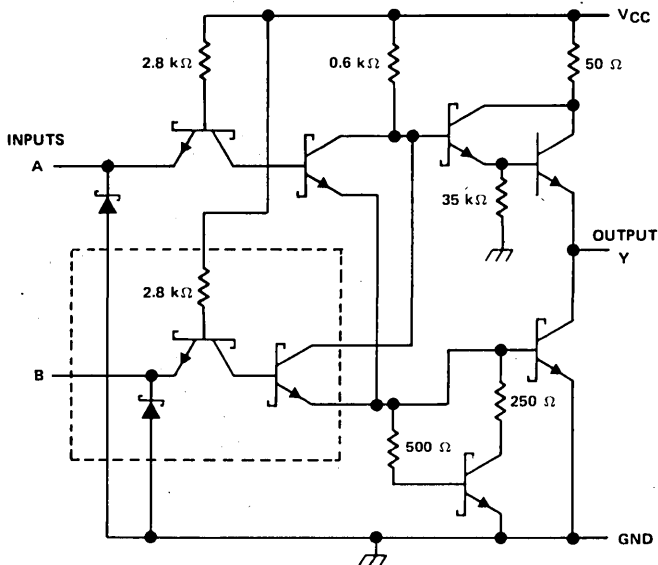

Resistor values shown are nominal.
The portion of the schematic within the dashed-line is repeated for each additional input.

absolute maximum ratings over operating free-air temperature range (unless otherwise noted)

Supply voltage, V_{CC} (see Note 1)	7 V
Input voltage	5.5 V
Operating free-air temperature range: SN54'	-55°C to 125°C
SN74'	0°C to 70°C
Storage temperature range	-65°C to 150°C

NOTE 1: Voltage values are with respect to network ground terminal.

3

TTL DEVICES

recommended operating conditions

	SN54S260			SN74S260			UNIT
	MIN	TYP	MAX	MIN	TYP	MAX	
V _{CC} Supply voltage	4.5	5	5.5	4.75	5	5.25	V
V _{IH} High-level input voltage	2			2			V
V _{IL} Low-level input voltage	0.8			0.8			V
I _{OH} High-level output current	-1			-1			mA
I _{OL} Low-level output current	20			20			mA
T _A Operating free-air temperature	-55			125			°C

electrical characteristics over recommended operating free-air temperature range (unless otherwise noted)

PARAMETER	TEST CONDITIONS †	SN54S260			SN74S260			UNIT
		MIN	TYP ‡	MAX	MIN	TYP ‡	MAX	
V _{IK}	V _{CC} = MIN, I _I = -18 mA	-1.2			-1.2			V
V _{OH}	V _{CC} = MIN, V _{IL} = 0.8 V, I _{OH} = -1 mA	2.5	3.4		2.7	3.4	V	
V _{OL}	V _{CC} = MIN, V _{IH} = 2 V, I _{OL} = 20 mA	0.5			0.5			V
I _I	V _{CC} = MAX, V _I = 5.5 V	1			1			mA
I _{IH}	V _{CC} = MAX, V _{IH} = 2.7 V	50			50			µA
I _{IL}	V _{CC} = MAX, V _{IL} = 0.5 V	-2			-2			mA
I _{OS} §	V _{CC} = MAX	-40	-100		-40	-100	mA	
I _{CCH}	V _{CC} = MAX, V _I = 0 V	17 29			17 29			mA
I _{CCL}	V _{CC} = MAX, See Note 2	26 45			26 45			mA

† For conditions shown as MIN or MAX, use the appropriate value specified under recommended operating conditions.

‡ All typical values are at V_{CC} = 5 V, T_A = 25°C.

§ Not more than one output should be shorted at a time, and the duration of the short-circuit should not exceed one second.

NOTE 2: One input at 4.5 V, all others at GND.

switching characteristics, V_{CC} = 5 V, T_A = 25°C (see note 3)

PARAMETER	FROM (INPUT)	TO (OUTPUT)	TEST CONDITIONS	MIN	TYP	MAX	UNIT
t _{PLH}	Any	Y	R _L = 280 Ω, C _L = 15 pF		4	5.5	ns
t _{PHL}					4	6	ns

NOTE 3: See General Information Section for load circuits and voltage waveforms.

3
TTL DEVICES

TYPES SN54LS261, SN74LS261 2-BIT BY 4-BIT PARALLEL BINARY MULTIPLEXERS

MARCH 1974 — REVISED DECEMBER 1983

- Fast Multiplication . . . 5-Bit Product in 26 ns Typ
- Power Dissipation . . . 110 mW Typical
- Latch Outputs for Synchronous Operation
- Expandable for m-Bit-by-n-Bit Applications
- Fully Compatible with Most TTL and Other Saturated Low-Level Logic Families
- Diode-Clamped Inputs Simplify System Design

description

These low-power Schottky circuits are designed to be used in parallel multiplication applications. They perform binary multiplication in two's-complement form, two bits at a time.

The M inputs are for the multiplier bits and the B inputs are for the multiplicand. The Q outputs represent the partial product as a recoded base-4 number. This recoding effectively reduces the Wallace-tree hardware requirements by a factor of two.

The outputs represent partial products in one's-complement form generated as a result of multiplication. A simple rounding scheme using two additional gates is needed for each partial product to generate two's complement.

The leading (most-significant) bit of the product is inverted for ease in extending the sign to square (left justify) the partial-product bits.

The SN54LS261 is characterized for operation over the full military temperature range of -55°C to 125°C ; the SN74LS261 for operation from 0°C to 70°C .

SN54LS261 . . . J OR W PACKAGE
SN74LS261 . . . D, J OR N PACKAGE

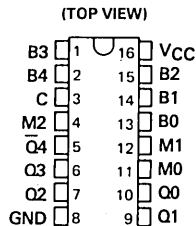

SN54LS261 . . . FK PACKAGE
SN74LS261 . . . FN PACKAGE

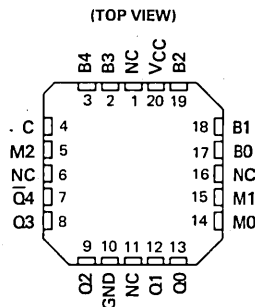

NC - No internal connection

FUNCTION TABLE

LATCH CONTROL C	INPUTS			OUTPUTS				
	M2	M1	M0	\bar{Q}_4	Q3	Q2	Q1	Q0
L	X	X	X	\bar{Q}_4	Q3	Q2	Q1	Q0
H	L	L	L	H	L	L	L	L
H	L	L	H	\bar{B}_4	B4	B3	B2	B1
H	L	H	L	\bar{B}_4	B4	B3	B2	B1
H	L	H	H	\bar{B}_4	B3	B2	B1	B0
H	H	L	L	B4	\bar{B}_3	\bar{B}_2	\bar{B}_1	\bar{B}_0
H	H	L	H	B4	\bar{B}_4	\bar{B}_3	\bar{B}_2	\bar{B}_1
H	H	H	L	B4	\bar{B}_4	\bar{B}_3	\bar{B}_2	\bar{B}_1
H	H	H	H	H	L	L	L	L

H = high level, L = low level, X = irrelevant
 $\bar{Q}_4 \dots Q_0$ = The logic level of the same output before the high-to-low transition of C.
 $B_4 \dots B_0$ = The logic level of the indicated multiplicand (B) input.

PRODUCTION DATA

This document contains information current as of publication date. Products conform to specifications per the terms of Texas Instruments standard warranty. Production processing does not necessarily include testing of all parameters.

TEXAS
INSTRUMENTS

POST OFFICE BOX 225012 • DALLAS, TEXAS 75265

TTL DEVICES

TYPES SN54LS261, SN74LS261

2-BIT BY 4-BIT PARALLEL BINARY MULTIPLEXERS

schematics of inputs and outputs

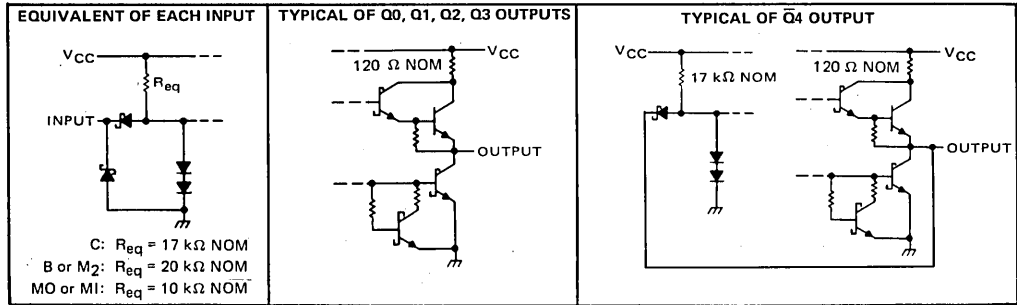

logic diagram

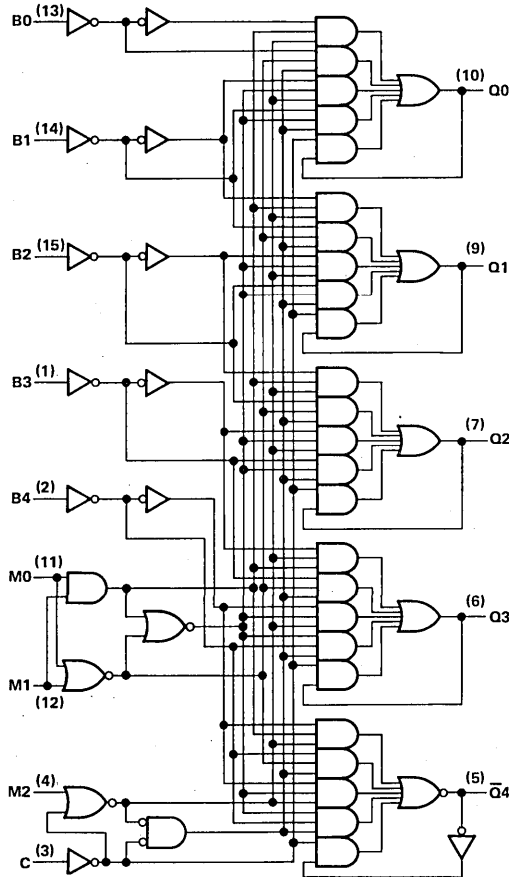

Pin numbers shown on logic notation are for D, J or N packages.

3

TTL DEVICES

TYPES SN54LS261, SN74LS261

2-BIT BY 4-BIT PARALLEL BINARY MULTIPLEXERS

absolute maximum ratings over operating free-air temperature range (unless otherwise noted)

Supply voltage, V_{CC} (see Note 1)	7 V
Input voltage	7 V
Operating free-air temperature range: SN54LS261	-55°C to 125°C
SN74LS261	0°C to 70°C
Storage temperature range	-65°C to 150°C

NOTE 1: Voltage values are with respect to network ground terminal.

recommended operating conditions

	SN54LS261			SN74LS261			UNIT
	MIN	NOM	MAX	MIN	NOM	MAX	
Supply voltage, V_{CC}	4.5	5	5.5	4.75	5	5.25	V
High-level output current, I_{OH}			-400			-400	μ A
Low-level output current, I_{OL}			4			8	mA
Width of enable pulse, t_w		25			25		ns
Setup time, t_{SU}	Any M input	17↓		17↓			ns
	Any B input	15↓		15↓			
Hold time, t_h	Any M input	0↓		0↓			ns
	Any B input	0↓		0↓			
Operating free-air temperature, T_A		-55	125		0	70	°C

↓ The arrow indicates that the falling edge of the enable pulse is used for reference.

electrical characteristics over recommended operating free-air temperature range (unless otherwise noted)

PARAMETER	TEST CONDITIONS†	SN54LS261			SN74LS261			UNIT
		MIN	TYP‡	MAX	MIN	TYP‡	MAX	
V_{IH} High-level input voltage		2			2			V
V_{IL} Low-level input voltage				0.7			0.8	V
V_{IK} Input clamp voltage	$V_{CC} = \text{MIN}, I_I = -18 \text{ mA}$			-1.5			-1.5	V
V_{OH} High-level output voltage	$V_{CC} = \text{MIN}, V_{IH} = 2 \text{ V}, V_{IL} = V_{IL} \text{ max}, I_{OH} = -400 \mu\text{A}$	2.5	3.4		2.7	3.4		V
V_{OL} Low-level output voltage	$V_{CC} = \text{MIN}, V_{IH} = 2 \text{ V}, V_{IL} = V_{IL} \text{ max}$	$I_{OL} = 4 \text{ mA}$	0.25	0.4	0.25	0.4		V
		$I_{OL} = 8 \text{ mA}$			0.35	0.5		
I_I Input current at maximum input voltage	$V_{CC} = \text{MAX}, V_I = 7 \text{ V}$	MO or MI		0.2		0.2		mA
		All others		0.1		0.1		
I_{IH} High-level input current	$V_{CC} = \text{MAX}, V_I = 2.7 \text{ V}$	MO or MI		40		40		μ A
		All others		20		20		
I_{IL} Low-level input current	$V_{CC} = \text{MAX}, V_I = 0.4 \text{ V}$	MO or MI		-0.8		-0.8		mA
		All others		-0.4		-0.4		
I_{OS} Short-circuit output current‡	$V_{CC} = \text{MAX}$	-20		-100	-20		-100	mA
I_{CC} Supply current	$V_{CC} = \text{MAX},$ All inputs at 0 V, Outputs open		20	38		20	40	mA

† All typical values are at $V_{CC} = 5 \text{ V}, T_A = 25^\circ\text{C}$.

‡ Not more than one output should be shorted at a time and duration of the output short-circuit should not exceed one second.

switching characteristics, $V_{CC} = 5 \text{ V}, T_A = 25^\circ\text{C}$

PARAMETER†	FROM (INPUT)	TO (OUTPUT)	TEST CONDITIONS	MIN	TYP	MAX	UNIT
t_{PLH}	C	Any Q	$C_L = 15 \text{ pF},$ $R_L = 2 \text{ k}\Omega,$ See Note 2		22	35	ns
t_{PHL}					20	30	ns
t_{PLH}	Any M input	Any Q			25	40	ns
t_{PHL}					22	35	ns
t_{PLH}	Any B input	Any Q			27	42	ns
t_{PHL}					24	37	ns

† t_{PLH} = propagation delay time, low-to-high-level output; t_{PHL} = propagation delay time, high-to-low-level output.

NOTE 2: See General Information Section for load circuits and voltage waveforms.

TTL DEVICES

TYPES SN54LS261, SN74LS261 2-BIT BY 4-BIT PARALLEL BINARY MULTIPLEXERS

TYPICAL APPLICATION DATA

Multiplication of the numbers 26 (multiplicand) by 29 (multiplier) in decimal, binary, and 2-bit-at-a-time-binary is shown here:

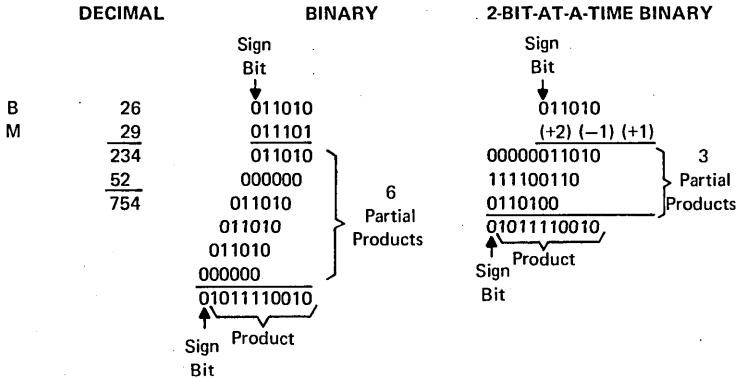

Two points should be noted in the two-bit-at-a-time-binary example above. First, in positioning the partial products beneath each other for final addition, each partial product is shifted two places to the left of the partial products above it instead of one place as is done in regular multiplication. Second, the msb of the partial product (the sign bit) is extended to the sign-bit column of the final answer.

A substantial reduction of multiplication time, cost, and power is obtained by implementing a parallel partial-product-generation scheme using a 2-bit-at-a-time algorithm, followed by a Wallace Tree summation.

Partial-product-generation rules of the algorithm are:

1. Examine two bits of multiplier M plus the next lower bit. For the first partial product (PP1) the next lower bit is zero.

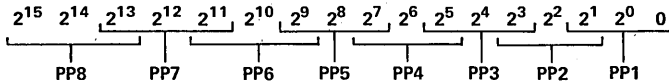

TYPES SN54LS261, SN74LS261 2-BIT BY 4-BIT PARALLEL BINARY MULTIPLEXERS

TYPICAL APPLICATION DATA

2. Generate partial product (PPi) as shown in the following table:

MULTIPLIER BITS FROM STEP 1			OPERATOR SYMBOL	TO OBTAIN PARTIAL PRODUCT
2^{2i-1}	2^{2i-2}	2^{2i-3}		
0	0	0	0	Replace multiplicand by zero
0	0	1	+1 B	Copy multiplicand
0	1	0	+1 B	Copy multiplicand
0	1	1	+2 B	Shift multiplicand left one bit
1	0	0	-2 B	Shift two's complement of multiplicand left one bit
1	0	1	-1 B	Replace multiplicand by two's complement
1	1	0	-1 B	Replace multiplicand by two's complement
1	1	1	0	Replace multiplicand by zero

3. Weight the partial products by indexing each two places left relative to the next-less-significant product.

4. Extend the most-significant bit of the partial product to the sign-bit place value of the final product.

EXAMPLE OF ALGORITHM

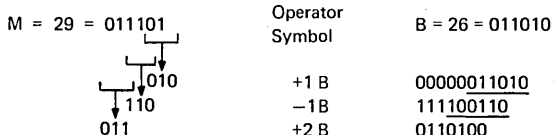

The summation of these partial products was shown in the 2-bit-at-a-time binary multiplication example above.

The 'LS261 generates partial products according to this algorithm with two exceptions:

1. The one's complement is generated for the cases requiring the two's complement. The two's complement can be obtained by adding one to the one's complement; this rounding can be done by using one NAND gate and one AND gate as shown in Figure B.
2. The most-significant bit is complemented to reduce the hardware required to extend the sign bit. This extension can be accomplished by adding a hard-wired logic 1 in bit position 2^{2i+15} of each partial product and also in bit position 2^{16} of the first partial product (PP1).

3
TTL DEVICES

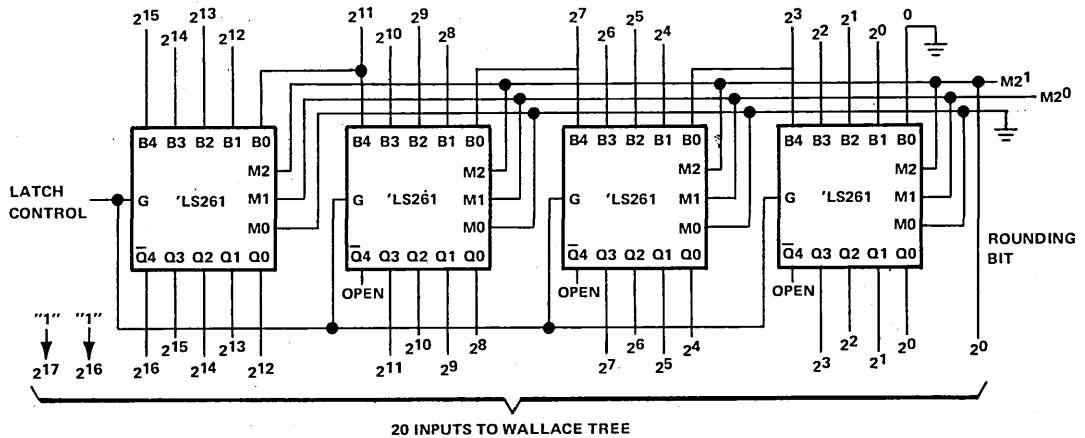

FIGURE A - FIRST PARTIAL PRODUCT, PP1

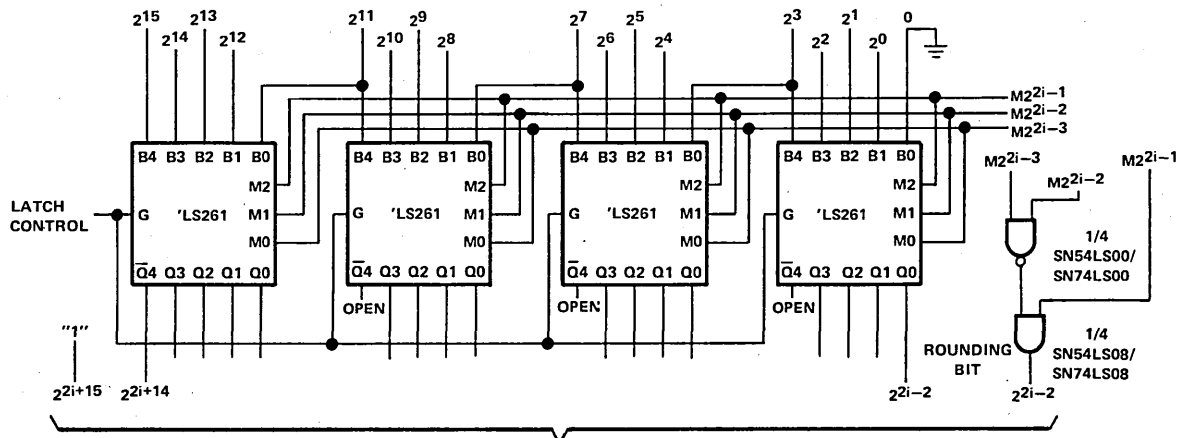

FIGURE B - OTHER PARTIAL PRODUCTS, PPi

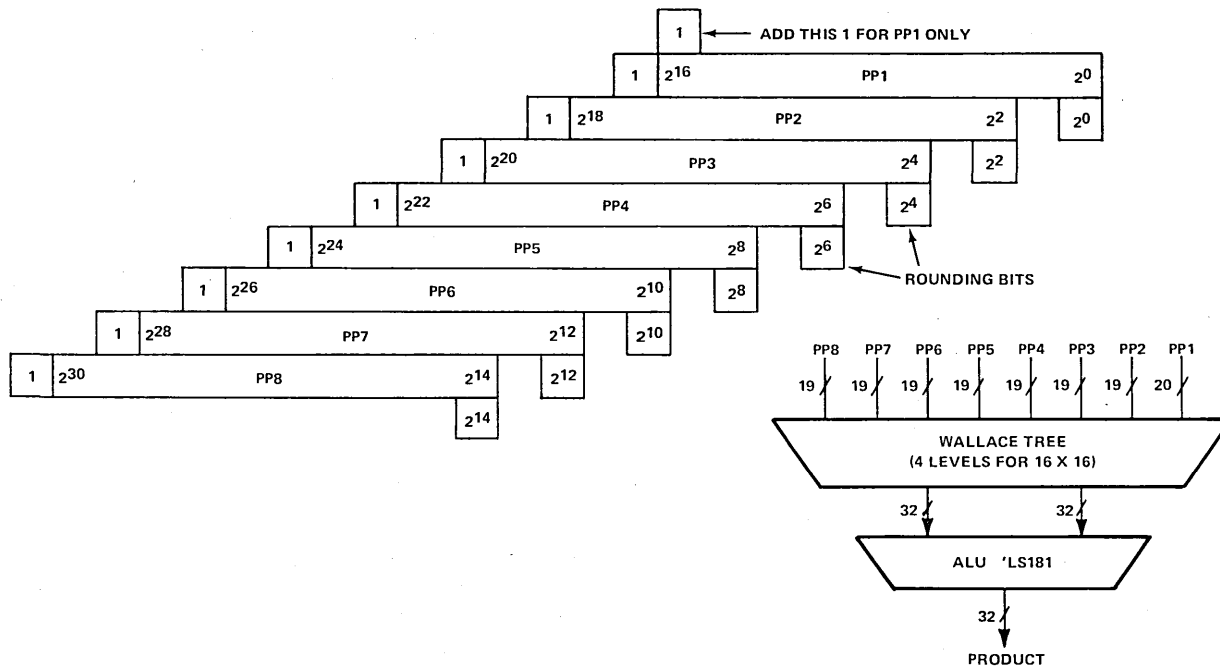

FIGURE C—MANIPULATION OF PARTIAL PRODUCTS FOR ENTRY INTO WALLACE TREE

In general, the 4 x 2 bit 'LS261 can be expanded for use in 4m x 2n bit multipliers. Partial-product generation uses m x n 'LS261s, m x n ÷ 16 'LS00s, and m x n ÷ 16 'LS08s. The size of the Wallace tree and ALU requirements vary depending on the size of the problem. The count for the 16 x 16 bit multiplier is:

32	SN54LS261/SN74LS261
2	SN54LS00/SN74LS00
2	SN54LS08/SN74LS08
56	SN54LS183/SN74LS183
7	SN54LS181/SN74LS181
2	SN54S182/SN74S182

TYPES SN54265, SN74265 QUADRUPLE COMPLEMENTARY-OUTPUT ELEMENTS

REVISED DECEMBER 1983

FOR SYMMETRICAL GENERATION OF COMPLEMENTARY TTL SIGNALS

- Switching Time Skew of the Complementary Outputs Is Typically 0.5 ns . . . Guaranteed to be No More than 3 ns at Rated Loading
- Full Fan-Out to 20 High-Level and 10 Low-Level 54/74 Loads
- Active Pull-Down Provides Square Transfer Characteristic

SN54265 . . . J OR W PACKAGE
SN74265 . . . J OR N PACKAGE

(TOP VIEW)

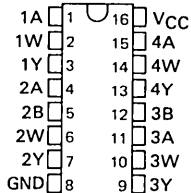

NC - No internal connection

description

The SN54265 and SN74265 circuits feature complementary outputs from each logic element, which have virtually symmetrical switching time delays from the triggering input. They are designed specifically for use in applications such as:

- Symmetrical clock/ $\overline{\text{clock}}$ generators
- Complementary input circuit for decoders and code converters
- Switch debouncing
- Differential line driver

Examples of these four functions are illustrated in the typical application data.

The SN54265 is characterized for operation over the full military temperature range of -55°C to 125°C ; the SN74265 is characterized for operation from 0°C to 70°C .

schematics of inputs and outputs

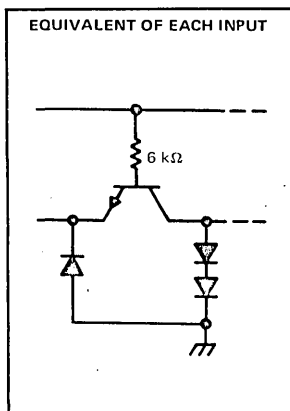

logic diagrams

ELEMENTS 1 and 4

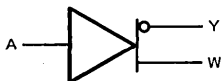

positive logic

$$Y = \overline{A} \quad W = A$$

ELEMENTS 2 and 3



positive logic

$$Y = \overline{AB} \text{ or } Y = \overline{A + B}$$

$$W = AB \text{ or } W = \overline{A + B}$$

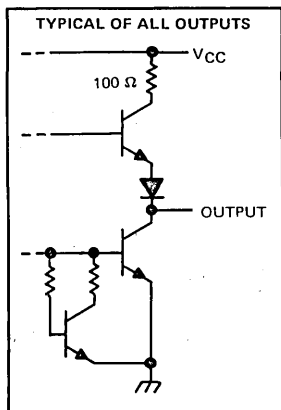

PRODUCTION DATA

This document contains information current as of publication date. Products conform to these specifications per the terms of Texas Instruments standard warranty. Production processing does not necessarily include testing of all parameters.

3-878

TEXAS
INSTRUMENTS

POST OFFICE BOX 225012 • DALLAS, TEXAS 75265

TYPES SN54265, SN74265 QUADRUPLE COMPLEMENTARY-OUTPUT ELEMENTS

absolute maximum ratings over operating free-air temperature range (unless otherwise noted)

Supply voltage, V_{CC} (see Note 1)	7 V
Input voltage	5.5 V
Operating free-air temperature range: SN54265	-55°C to 125°C
SN74265	0°C to 70°C
Storage temperature range	-65°C to 150°C

NOTE 1: Voltage values are with respect to network ground terminal.

recommended operating conditions

	SN54265			SN74265			UNIT
	MIN	NOM	MAX	MIN	NOM	MAX	
Supply voltage, V_{CC}	4.5	5	5.5	4.75	5	5.25	V
High-level output current, I_{OH}	-800			-800			μ A
Low-level output current, I_{OL}	16			16			mA
Operating free-air temperature, T_A	-55		125	0		70	°C

electrical characteristics over recommended operating free-air temperature range (unless otherwise noted)

PARAMETER	TEST CONDITIONS†	MIN	TYP‡	MAX	UNIT	
V_{IH} High-level input voltage		2			V	
V_{IL} Low-level input voltage		0.8			V	
V_{IK} Input clamp voltage	$V_{CC} = \text{MIN}$, $I_I = -12 \text{ mA}$	-1.5			V	
V_{OH} High-level output voltage	$V_{CC} = \text{MIN}$, $I_{OH} = -800 \mu\text{A}$	2.4	3.4		V	
V_{OL} Low-level output voltage	$V_{CC} = \text{MIN}$, $I_{OL} = 16 \text{ mA}$	0.2		0.4	V	
I_I Input current at maximum input voltage	$V_{CC} = \text{MAX}$, $V_I = 5.5 \text{ V}$	1			mA	
I_{IH} High-level input current	$V_{CC} = \text{MAX}$, $V_I = 2.4 \text{ V}$	40			μ A	
I_{IL} Low-level input current	$V_{CC} = \text{MAX}$, $V_I = 0.4 \text{ V}$	-1.6			mA	
I_{OS} Short-circuit output current §	SN54265	-20			-57	mA
	SN74265	-18			-57	
I_{CC} Supply current	$V_{CC} = \text{MAX}$, See Note 2	25		34	mA	

†For conditions shown as MIN or MAX, use the appropriate value specified under recommended operating conditions.

‡All typical values are at $V_{CC} = 5 \text{ V}$, $T_A = 25^\circ \text{C}$.

§Not more than one output should be shorted at a time.

NOTE 2: I_{CC} is measured with all outputs open and all inputs grounded.

switching characteristics, $V_{CC} = 5 \text{ V}$, $T_A = 25^\circ \text{C}$

PARAMETER¶	FROM (INPUT)	TO (OUTPUT)	TEST CONDITIONS	MIN	TYP	MAX	UNIT
$t_{PLH}(W)$	A or B	W	$R_L = 400 \Omega$, $C_L = 15 \text{ pF}$, See Note 3	11.6		18	ns
$t_{PHL}(Y)$	(as applicable)	Y		11.3		18	
$t_{PHL}(W)$	A or B	W		9.8		18	ns
$t_{PLH}(Y)$	(as applicable)	Y		10.2		18	
$t_{PLH}(W) - t_{PHL}(Y)$	A or B	W with respect to Y		+0.3		± 3	ns
$t_{PHL}(W) - t_{PLH}(Y)$	(as applicable)			-0.4		± 3	

¶ t_{PLH} \equiv Propagation delay time, low-to-high-level output.

¶ t_{PHL} \equiv Propagation delay time, high-to-low-level output.

¶ $t_{PX}(W) - t_{PX}(Y)$ \equiv Difference in indicated propagation delay times at the W and Y outputs, respectively.

NOTE 3: See General Information Section for load circuits and voltage waveforms.

3
TTL DEVICES

TYPES SN54265, SN74265
QUADRUPLE COMPLEMENTARY-OUTPUT ELEMENTS

TYPICAL CHARACTERISTICS†

PROPAGATION DELAY TIME DIFFERENCE
 vs
 FREE-AIR TEMPERATURE

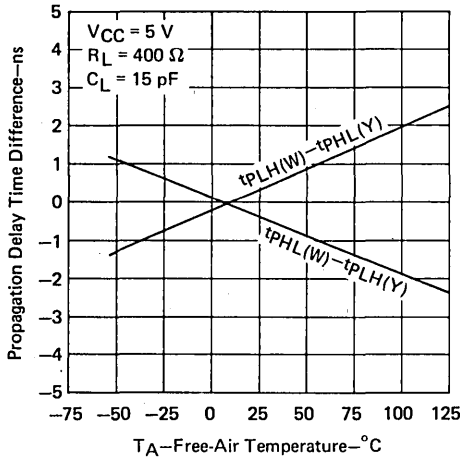

FIGURE 1

PROPAGATION DELAY TIME DIFFERENCE
 vs
 SUPPLY VOLTAGE

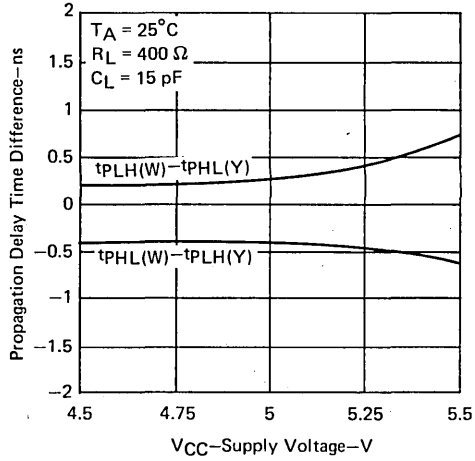

FIGURE 2

PROPAGATION DELAY TIME DIFFERENCE vs LOAD CAPACITANCE

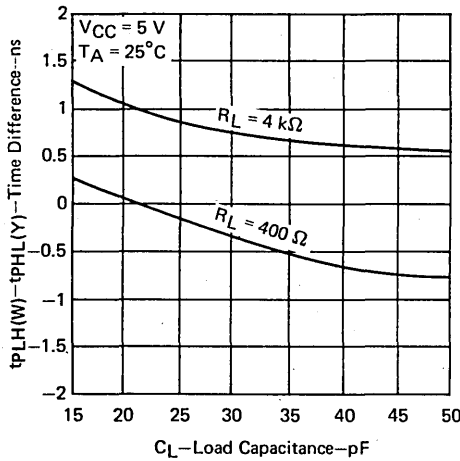

FIGURE 3

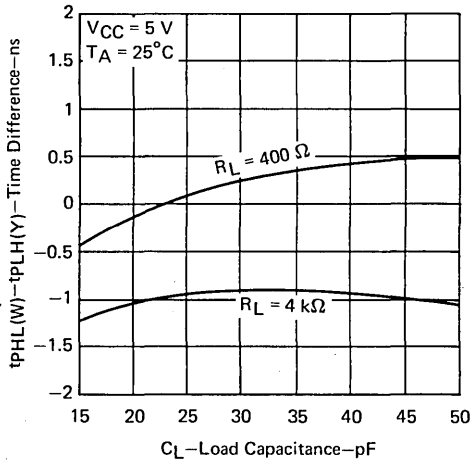

FIGURE 4

†Data for temperatures below 0°C and above 70°C and for supply voltages below 4.75 V and above 5.25 V are applicable for SN54265 only.

TYPES SN54265, SN74265 QUADRUPLE COMPLEMENTARY-OUTPUT ELEMENTS

TYPICAL APPLICATION DATA

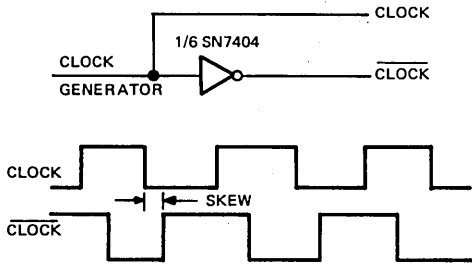

FIGURE A - TYPICAL CLOCK/CLOCK GENERATOR CIRCUIT

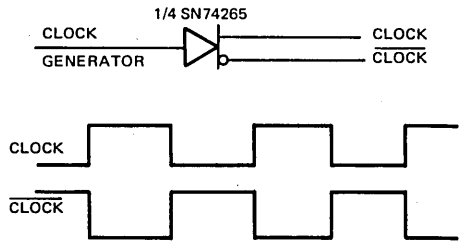

FIGURE B - SKEWLESS CLOCK/CLOCK GENERATOR CIRCUIT

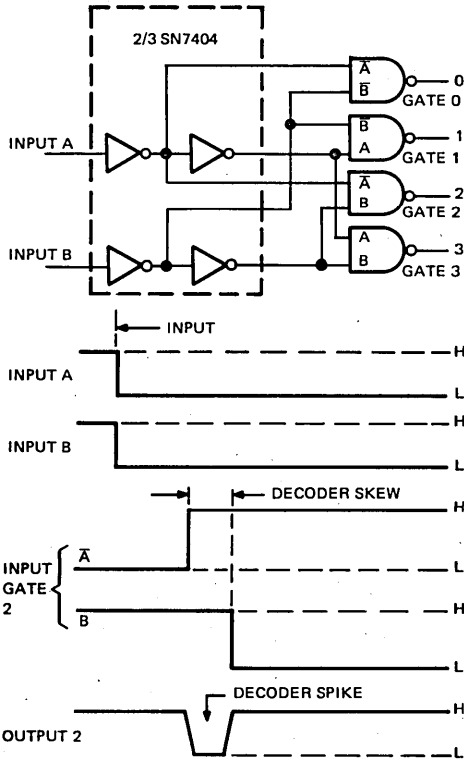

FIGURE C - TYPICAL DECODER/CODE CONVERTER

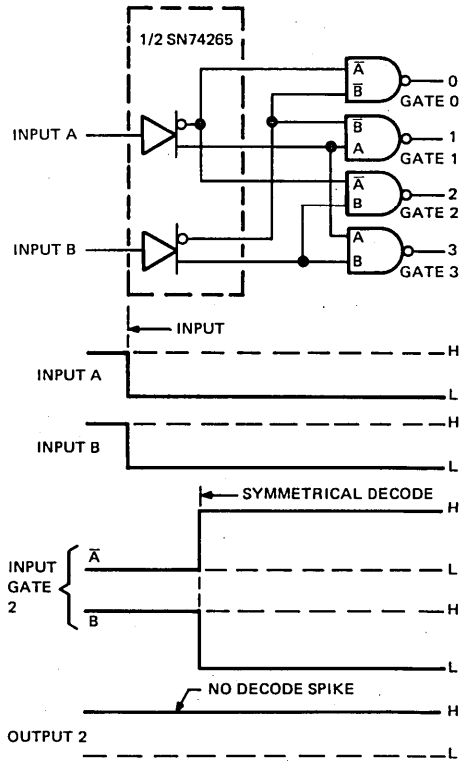

FIGURE D - SYMMETRICAL DECODER/CODE CONVERTER

3

TTL DEVICES

**TYPES SN54265, SN74265
QUADRUPLE COMPLEMENTARY-OUTPUT ELEMENTS**

TYPICAL APPLICATION DATA

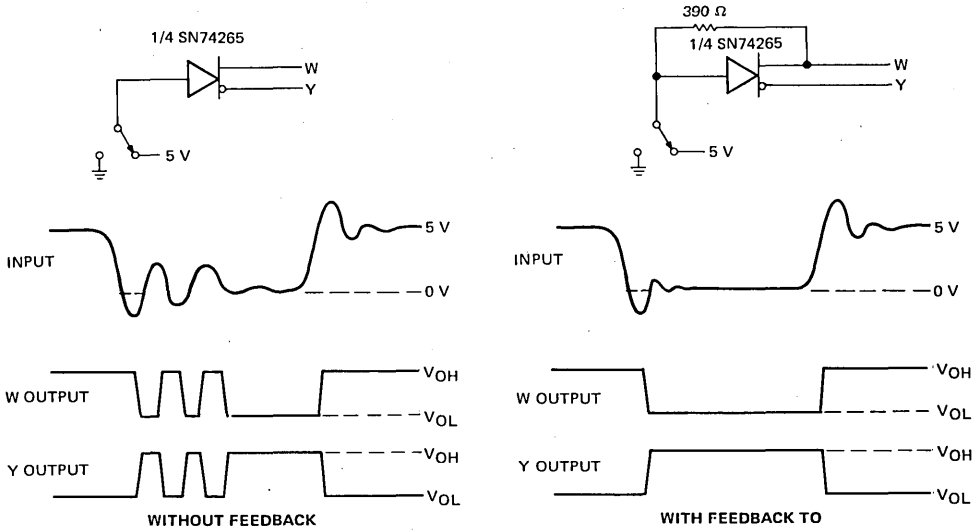
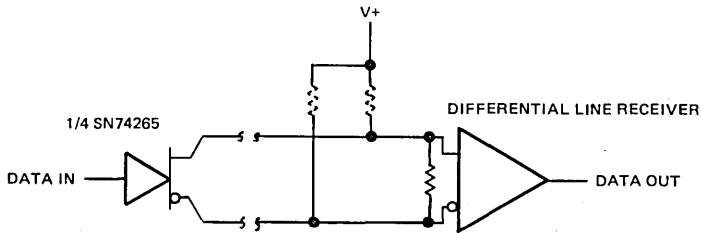

FIGURE E - SWITCH DEBOUNCER

3

TTL DEVICES



Noise immunity typically 3 V
for either high level or low level data

FIGURE F - DIFFERENTIAL LINE DRIVER

TYPES SN54LS266, SN74LS266 QUADRUPLE 2-INPUT EXCLUSIVE-NOR GATES WITH OPEN-COLLECTOR OUTPUTS

DECEMBER 1972—REVISED DECEMBER 1983

- Can Be Used as a 4-Bit Digital Comparator
- Input Clamping Diodes Simplify System Design
- Fully Compatible with Most TTL Circuits

FUNCTION TABLE

INPUTS		OUTPUT
A	B	Y
L	L	H
L	H	L
H	L	L
H	H	H

H = high level, L = low level

description

The 'LS266 is comprised of four independent 2-input exclusive-NOR gates with open-collector outputs. The open-collector outputs permit tying outputs together for multiple-bit comparisons.

logic symbol (each gate)



positive logic

$$Y = \overline{A \oplus B} = AB + \overline{AB}$$

schematic of inputs and outputs

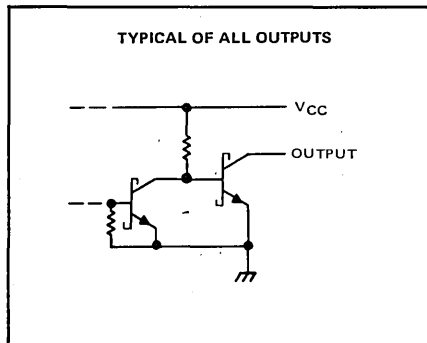
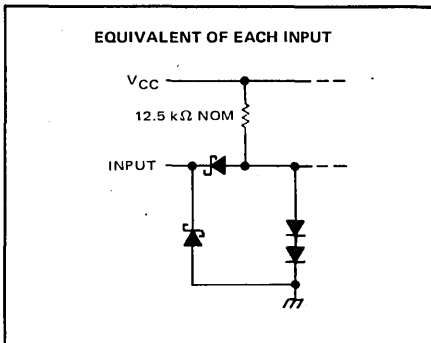

SN54LS266 ... J OR W PACKAGE
SN74LS266 ... D, J OR N PACKAGE
(TOP VIEW)

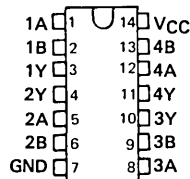

SN54LS266 ... FK PACKAGE
SN74LS266 ... FN PACKAGE
(TOP VIEW)

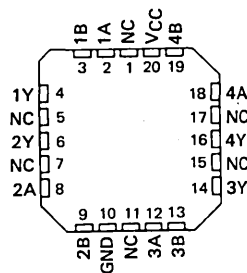

NC - No internal connection

PRODUCTION DATA
This document contains information current as of publication date. Products conform to specifications per the terms of Texas Instruments standard warranty. Production processing does not necessarily include testing of all parameters.

**TEXAS
INSTRUMENTS**

POST OFFICE BOX 225012 • DALLAS, TEXAS 75265

3-883

TYPES SN54LS266, SN74LS266 QUADRUPLE 2-INPUT EXCLUSIVE-NOR GATES WITH OPEN-COLLECTOR OUTPUTS

absolute maximum ratings over operating free-air temperature range (unless otherwise noted)

Supply voltage, V_{CC} (see Note 1)	7 V
Input voltage	7 V
Operating free-air temperature range: SN54LS266	-55°C to 125°C
SN74LS266	0°C to 70°C
Storage temperature range	-65°C to 150°C

NOTE 1: Voltage values are with respect to network ground terminal.

recommended operating conditions

	SN54LS266			SN74LS266			UNIT		
	MIN	NOM	MAX	MIN	NOM	MAX			
Supply voltage, V_{CC}	4.5	5	5.5	4.75	5	5.25	V		
High-level output voltage, V_{OH}	5.5			5.5			V		
Low-level output current, I_{OL}	4			8			mA		
Operating free-air temperature, T_A	-55			125			0	70	°C

electrical characteristics over recommended operating free-air temperature range (unless otherwise noted)

PARAMETER	TEST CONDITIONS†	SN54LS266			SN74LS266			UNIT
		MIN	TYP‡	MAX	MIN	TYP‡	MAX	
V_{IH} High-level input voltage		2			2			V
V_{IL} Low-level input voltage		0.7			0.8			V
V_{IK} Input clamp voltage	$V_{CC} = \text{MIN}$, $I_I = -18 \text{ mA}$	-1.5			-1.5			V
I_{OH} High-level output current	$V_{CC} = \text{MIN}$, $V_{IH} = 2 \text{ V}$, $V_{IL} = V_{IL \text{ max}}$, $V_{OH} = 5.5 \text{ V}$	100			100			μA
V_{OL} Low-level output voltage	$V_{CC} = \text{MIN}$, $V_{IH} = 2 \text{ V}$, $V_{IL} = V_{IL \text{ max}}$	$I_{OL} = 4 \text{ mA}$	0.25	0.4	0.25	0.4	V	
		$I_{OL} = 8 \text{ mA}$			0.35	0.5		
I_I Input current at maximum input voltage	$V_{CC} = \text{MAX}$, $V_I = 7 \text{ V}$	0.2			0.2			mA
I_{IH} High-level input current	$V_{CC} = \text{MAX}$, $V_I = 2.7 \text{ V}$	40			40			μA
I_{IL} Low-level input current	$V_{CC} = \text{MAX}$, $V_I = 0.4 \text{ V}$	-0.8			-0.8			mA
I_{CC} Supply current	$V_{CC} = \text{MAX}$, See Note 2	8	13	8	13	8	13	mA

† For conditions shown as MIN or MAX, use the appropriate value specified under recommended operating conditions for the applicable type.

‡ All typical values are at $V_{CC} = 5 \text{ V}$, $T_A = 25^\circ\text{C}$.

NOTE 2: I_{CC} is measured with one input of each gate at 4.5 V, the other inputs grounded, and the outputs open.

switching characteristics, $V_{CC} = 5 \text{ V}$, $T_A = 25^\circ\text{C}$

PARAMETER¶	FROM (INPUT)	TEST CONDITIONS		MIN	TYP	MAX	UNIT
		Other input low	Other input high				
t_{PLH}	A or B	Other input low	$C_L = 15 \text{ pF}$, $R_L = 2 \text{ k}\Omega$, See Note 3	18	30	ns	
t_{PHL}				18	30		
t_{PLH}	A or B	Other input high		18	30	ns	
t_{PHL}				18	30		

¶ t_{PLH} propagation delay time, low-to-high-level output

t_{PHL} propagation delay time, high-to-low-level output

NOTE 3: See General Information Section for load circuits and voltage waveforms.

3 TTL DEVICES

TYPES SN54S268, SN74S268 HEX D-TYPE TRANSPARENT LATCHES WITH 3-STATE OUTPUTS

DECEMBER 1983

- 6 Latches in a Single Package
- 3-State Bus-Driving True Outputs
- Full Parallel Access for Loading
- Buffered Control Inputs
- PNP Inputs Reduce D-C Loading on Data Lines
- HEX Version of 'S373

description

These 6-bit latches feature three-state outputs designed specifically for driving highly capacitive or relatively low-impedance loads. They are particularly suitable for implementing buffer registers, I/O ports, bidirectional bus drivers, and working registers.

The six latches of the 'S268 are transparent D-type latches. While the enable (C) is high the Q outputs will follow the data (D) inputs. When the enable is taken low, the Q outputs will be latched at the levels that were set up at the D inputs.

Schmitt-trigger buffered inputs at the enable/clock lines simplify system design as ac and dc noise rejection is improved by typically 400 mV due to the input hysteresis. A buffered output control input can be used to place the eight outputs in either a normal logic state (high or low logic levels) or a high-impedance state. In the high-impedance state the outputs neither load nor drive the bus lines significantly.

The output control \overline{OC} does not affect the internal operations of the latches. Old data can be retained or new data can be entered while the outputs are off.

The SN54S268 is characterized for operation over the full military temperature range of -55°C to 125°C . The SN74S268 is characterized for operation from 0°C to 70°C .

SN54S268 ... J PACKAGE
SN74S268 ... D, J OR N PACKAGE
(TOP VIEW)

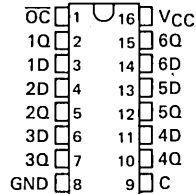

SN54S268 ... FK PACKAGE
SN74S268 ... FN PACKAGE
(TOP VIEW)

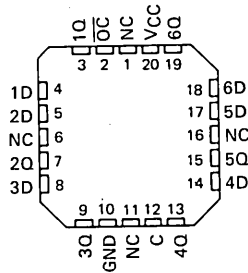

NC - No internal connection

FUNCTION TABLE (EACH LATCH)

INPUTS			OUTPUT
\overline{OC}	ENABLE C	D	Q
L	H	H	H
L	H	L	L
L	L	X	Q_0
H	X	X	Z

PRODUCTION DATA
This document contains information current as of publication date. Products conform to specifications per the terms of Texas Instruments standard warranty. Production processing does not necessarily include testing of all parameters.

TEXAS INSTRUMENTS
POST OFFICE BOX 225012 • DALLAS, TEXAS 75265

3-885

TTL DEVICES

TYPES SN54S268, SN74S268

HEX D-TYPE TRANSPARENT LATCHES WITH 3-STATE OUTPUTS

logic symbol

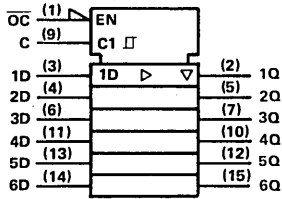

Pin numbers shown on logic notation are for D, J or N packages.

logic diagram (positive logic)

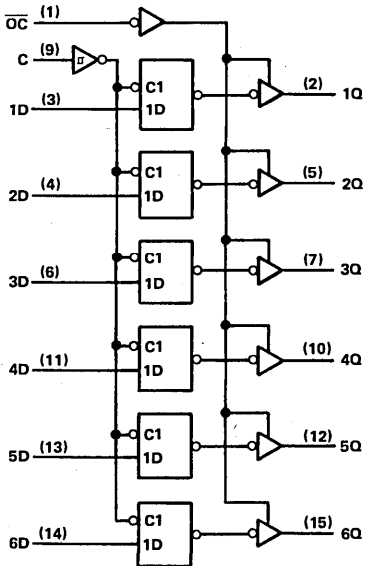

schematics of inputs and outputs

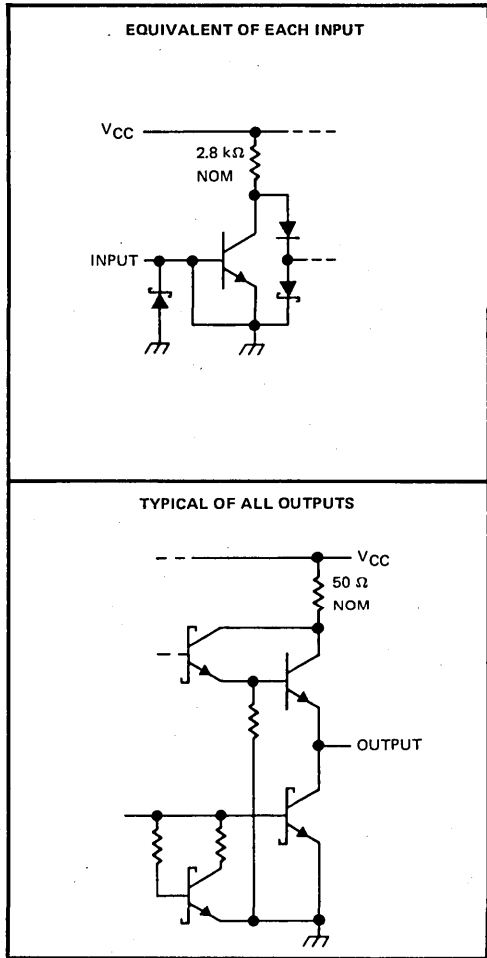

3 TTL DEVICES

absolute maximum ratings over operating free-air temperature range (unless otherwise noted)

Supply voltage, V_{CC} (see Note 1)	7 V
Input voltage	5.5 V
Voltage applied to a disabled 3-state output	5.5 V
Operating free-air temperature range: SN54S268	-55°C to 125°C
SN74S268	0°C to 70°C
Storage temperature range	-65°C to 150°C

NOTE 1: Voltage values are with respect to network ground terminal.

TYPES SN54S268, SN74S268 HEX D-TYPE TRANSPARENT LATCHES WITH 3-STATE OUTPUTS

recommended operating conditions

	SN54S268			SN74S268			UNIT
	MIN	NOM	MAX	MIN	NOM	MAX	
V _{CC} Supply voltage	4.5	5	5.5	4.75	5	5.25	V
V _{IH} High-level input voltage	2			2			V
V _{IL} Low-level input voltage			0.8			0.8	V
I _{OH} High-level output current			-2			-6.5	mA
I _{OL} Low-level output current			20			20	mA
t _w Pulse duration, enable C	High	6		6			ns
	Low	7.3		7.3			ns
t _{su} Setup time, data before enable C ↓		0		0			ns
t _h Hold time, data after enable C ↓		10		10			ns
T _A Operating free-air temperature		-55	125		0	70	°C

electrical characteristics over recommended operating free-air temperature range (unless otherwise noted)

PARAMETER	TEST CONDITIONS†			MIN	TYP‡	MAX	UNIT	
V _{IK}	V _{CC} = MIN, I _I = -18 mA					-1.2	V	
V _{OH}	SN54S'	V _{CC} = MIN, V _{IH} = 2 V, V _{IL} = 0.8 V, I _{OH} = MAX			2.4	3.4	V	
	SN74S'				2.4	3.1		
V _{OL}	V _{CC} = MIN, V _{IH} = 2 V, V _{IL} = 0.8 V, I _{OL} = 20 mA					0.5	V	
I _{OZH}	V _{CC} = MAX, V _{IH} = 2 V, V _O = 2.4 V					50	μA	
I _{OZL}	V _{CC} = MAX, V _{IH} = 2 V, V _O = 0.5 V					-50	μA	
I _I	V _{CC} = MAX, V _I = 5.5 V					1	mA	
I _{IH}	V _{CC} = MAX, V _I = 2.7 V					50	μA	
I _{IL}	V _{CC} = MAX, V _I = 0.5 V					-0.25	mA	
I _{OS} §	V _{CC} = MAX			-40		-100	mA	
I _{CC}	V _{CC} = MAX			Outputs high		54	94	mA
				Outputs low		67	119	
				Outputs disabled		81	136	

† For conditions shown as MIN or MAX, use the appropriate value specified under recommended operating conditions.

‡ All typical values are at V_{CC} = 5 V, T_A = 25°C.

§ Not more than one output should be shorted at a time and duration of the short circuit should not exceed one second.

switching characteristics, V_{CC} = 5 V, T_A = 25°C

PARAMETER	FROM (INPUT)	TO (OUTPUT)	TEST CONDITIONS	'S268			UNIT
				MIN	TYP	MAX	
t _{PLH}	D	Any Q	R _L = 280 Ω, See Note 2	C _L = 15 pF	7	12	ns
t _{PHL}					7	12	
t _{PLH}	C	Any Q			7	14	ns
t _{PHL}					12	18	
t _{PZH}	\overline{OC}	Any Q			8	15	ns
t _{PZL}					11	18	
t _{PHZ}	\overline{OC}	Any Q	R _L = 280 Ω, See Note 2	C _L = 5 pF	6	9	ns
t _{PLZ}			8		12		

NOTE: 2. See General Information Section for load circuits and voltage waveforms.

3
TTL DEVICES

TYPES SN54273, SN54LS273, SN74273, SN74LS273 OCTAL D-TYPE FLIP-FLOP WITH CLEAR

OCTOBER 1976 - REVISED DECEMBER 1983

- Contains Eight Flip-Flops with Single-Rail Outputs
- Buffered Clock and Direct Clear Inputs
- Individual Data Input to Each Flip-Flop
- Applications Include:
Buffer/Storage Registers
Shift Registers
Pattern Generators

SN54273, SN54LS273 ... J PACKAGE
SN74273 ... J OR N PACKAGE
SN74LS273 ... DW, J OR N PACKAGE
(TOP VIEW)

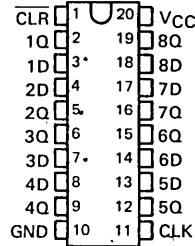

description

These monolithic, positive-edge-triggered flip-flops utilize TTL circuitry to implement D-type flip-flop logic with a direct clear input.

Information at the D inputs meeting the setup time requirements is transferred to the Q outputs on the positive-going edge of the clock pulse. Clock triggering occurs at a particular voltage level and is not directly related to the transition time of the positive-going pulse. When the clock input is at either the high or low level, the D input signal has no effect at the output:

These flip-flops are guaranteed to respond to clock frequencies ranging from 0 to 30 megahertz while maximum clock frequency is typically 40 megahertz. Typical power dissipation is 39 milliwatts per flip-flop for the '273 and 10 milliwatts for the 'LS273.

SN54LS273 ... FK PACKAGE
SN74LS273 ... FN PACKAGE
(TOP VIEW)

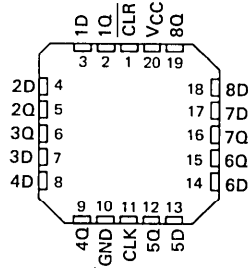

FUNCTION TABLE
(EACH FLIP-FLOP)

INPUTS			OUTPUT
CLEAR	CLOCK	D	Q
L	X	X	L
H	↑	H	H
H	↑	L	L
H	L	X	Q ₀

PRODUCTION DATA

This document contains information current as of publication date. Products conform to specifications per the terms of Texas Instruments standard warranty. Production processing does not necessarily include testing of all parameters.

3-888

TEXAS
INSTRUMENTS

POST OFFICE BOX 225012 • DALLAS, TEXAS 75265

TYPES SN54273, SN74273 OCTAL D-TYPE FLIP-FLOP WITH CLEAR

schematics of inputs and outputs

'273

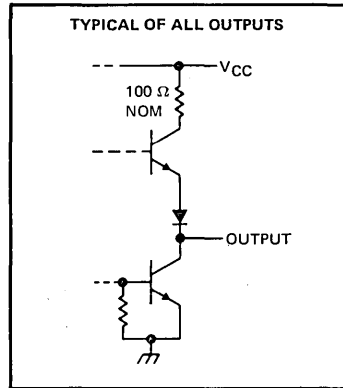
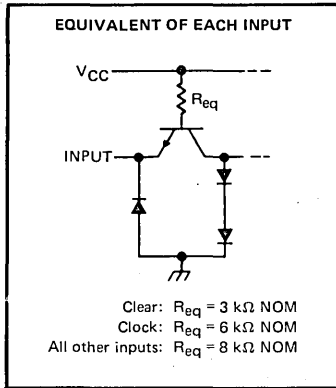

'LS273

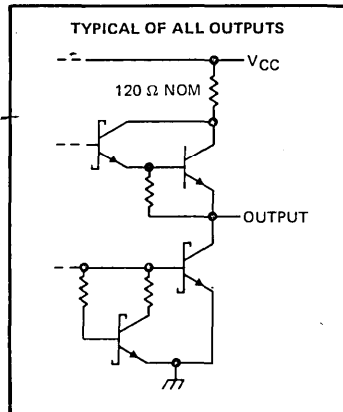
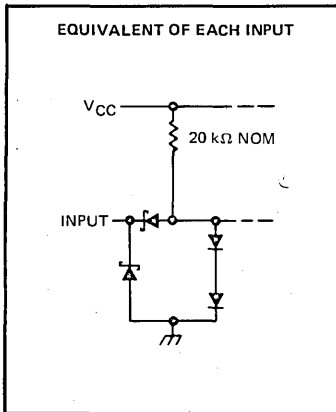

logic diagram

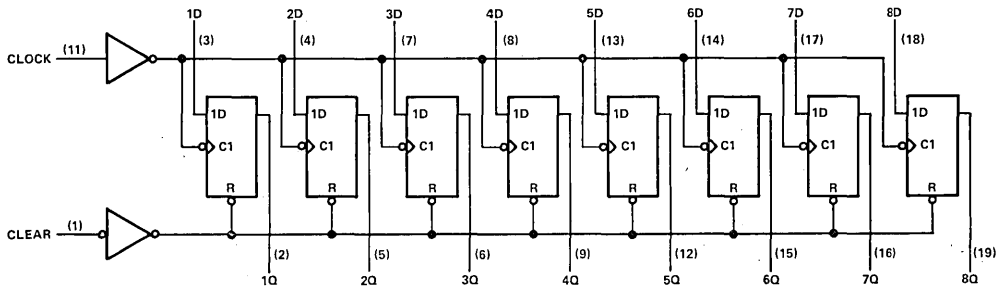

Pin numbers shown on logic notation are for DW, J or N packages.



TTL DEVICES

TEXAS
INSTRUMENTS

POST OFFICE BOX 225012 • DALLAS, TEXAS 75265

3-889

TYPES SN54273, SN74273 OCTAL D-TYPE FLIP-FLOP WITH CLEAR

absolute maximum ratings over operating free-air temperature range (unless otherwise noted)

Supply voltage, V_{CC} (see Note 1)	7 V
Input voltage	5.5 V
Operating free-air temperature range: SN54273	-55°C to 125°C
SN74273	0°C to 70°C
Storage temperature range	-65°C to 150°C

NOTE 1: Voltage values are with respect to network ground terminal.

recommended operating conditions

	SN54273			SN74273			UNIT
	MIN	NOM	MAX	MIN	NOM	MAX	
Supply voltage, V_{CC}	4.5	5	5.5	4.75	5	5.25	V
High-level output current, I_{OH}			-800			-800	μ A
Low-level output current, I_{OL}			16			16	mA
Clock frequency, f_{clock}	0		30	0		30	MHz
Width of clock or clear pulse, t_w	16.5			16.5			ns
Set-up time, t_{su}	Data input		20†	Data input		20†	ns
	Clear inactive state		25†	Clear inactive state		25†	
Data hold time, t_h			5†			5†	ns
Operating free-air temperature, T_A	-55	125		0	70		°C

†The arrow indicates that the rising edge of the clock pulse is used for reference.

electrical characteristics over recommended operating free-air temperature range (unless otherwise noted)

PARAMETER	TEST CONDITIONS†	MIN	TYP‡	MAX	UNIT
V_{IH} High-level input voltage		2			V
V_{IL} Low-level input voltage				0.8	V
V_{IK} Input clamp voltage	$V_{CC} = \text{MIN}, I_I = -12 \text{ mA}$			-1.5	V
V_{OH} High-level output voltage	$V_{CC} = \text{MIN}, V_{IH} = 2 \text{ V}, V_{IL} = 0.8 \text{ V}, I_{OH} = -800 \mu\text{A}$	2.4	3.4		V
V_{OL} Low-level output voltage	$V_{CC} = \text{MIN}, V_{IH} = 2 \text{ V}, V_{IL} = 0.8 \text{ V}, I_{OL} = 16 \text{ mA}$			0.4	V
I_I Input current at maximum input voltage	$V_{CC} = \text{MAX}, V_I = 5.5 \text{ V}$			1	mA
I_{IH} High-level input current	Clear			80	μ A
	Clock or D	$V_{CC} = \text{MAX}, V_I = 2.4 \text{ V}$		40	
I_{IL} Low-level input current	Clear			-3.2	mA
	Clock or D	$V_{CC} = \text{MAX}, V_I = 0.4 \text{ V}$		-1.6	
I_{OS} Short-circuit output current§	$V_{CC} = \text{MAX}$	-18		-57	mA
I_{CC} Supply current	$V_{CC} = \text{MAX}, \text{ See Note 2}$		62	94	mA

†For conditions shown as MIN or MAX, use the appropriate value specified under recommended operating conditions.

‡All typical values are at $V_{CC} = 5 \text{ V}, T_A = 25^\circ\text{C}$.

§Not more than one output should be shorted at a time.

NOTE 2: With all outputs open and 4.5 V applied to all data and clear inputs, I_{CC} is measured after a momentary ground, then 4.5 V, is applied to clock.

switching characteristics, $V_{CC} = 5 \text{ V}, T_A = 25^\circ\text{C}$

PARAMETER	TEST CONDITIONS	MIN	TYP	MAX	UNIT
f_{max} Maximum clock frequency	$C_L = 15 \text{ pF}, R_L = 400 \Omega, \text{ See Note 3}$	30	40		MHz
t_{PHL} Propagation delay time, high-to-low-level output from clear		18	27		ns
t_{PLH} Propagation delay time, low-to-high-level output from clock		17	27		ns
t_{PHL} Propagation delay time, high-to-low-level output from clock		18	27		ns

NOTE 3: See General Information Section for load circuits and voltage waveforms.

TYPES SN54LS273, SN74LS273 OCTAL D-TYPE FLIP-FLOP WITH CLEAR

absolute maximum ratings over operating free-air temperature range (unless otherwise noted)

Supply voltage, V_{CC} (see Note 1)	7 V
Input voltage	7 V
Operating free-air temperature range: SN54LS273	-55°C to 125°C
SN74LS273	0°C to 70°C
Storage temperature range	-65°C to 150°C

NOTE 1: Voltage values are with respect to network ground terminal

recommended operating conditions

	SN54LS273			SN74LS273			UNIT
	MIN	NOM	MAX	MIN	NOM	MAX	
Supply voltage, V_{CC}	4.5	5	5.5	4.75	5	5.25	V
High-level output current, I_{OH}			-400			-400	μ A
Low-level output current, I_{OL}			4			8	mA
Clock frequency, f_{clock}	0		30	0		30	MHz
Width of clock or clear pulse, t_w		20			20		ns
Set-up time, t_{su}	Data input	20†		20†			ns
	Clear inactive state	25†		25†			
Data hold time, t_h		5†			5†		ns
Operating free-air temperature, T_A		-55	125		0	70	°C

†The arrow indicates that the rising edge of the clock pulse is used for reference.

electrical characteristics over recommended operating free-air temperature range (unless otherwise noted)

PARAMETER	TEST CONDITIONS†	SN54LS273			SN74LS273			UNIT
		MIN	TYP‡	MAX	MIN	TYP‡	MAX	
V_{IH} High-level input voltage		2			2			V
V_{IL} Low-level input voltage				0.7			0.8	V
V_{IK} Input clamp voltage	$V_{CC} = \text{MIN}, I_I = -18 \text{ mA}$			-1.5			-1.5	V
V_{OH} High-level output voltage	$V_{CC} = \text{MIN}, V_{IH} = 2 \text{ V}, V_{IL} = V_{ILmax}, I_{OH} = -400 \mu\text{A}$	2.5	3.4		2.7	3.4		V
V_{OL} Low-level output voltage	$V_{CC} = \text{MIN}, V_{IH} = 2 \text{ V}, V_{IL} = V_{ILmax}, I_{OL} = 4 \text{ mA}$ $I_{OL} = 8 \text{ mA}$		0.25	0.4		0.25	0.4	V
I_I Input current at maximum input voltage	$V_{CC} = \text{MAX}, V_I = 7 \text{ V}$			0.1			0.1	mA
I_{IH} High-level input current	$V_{CC} = \text{MAX}, V_I = 2.7 \text{ V}$			20			20	μ A
I_{IL} Low-level input current	$V_{CC} = \text{MAX}, V_I = -0.4 \text{ V}$			-0.4			-0.4	mA
I_{OS} Short-circuit output current §	$V_{CC} = \text{MAX}$	-20		-100	-20		-100	mA
I_{CC} Supply current	$V_{CC} = \text{MAX}, \text{ See Note 2}$		17	27		17	27	mA

†For conditions shown as MIN or MAX, use the appropriate value specified under recommended operating conditions.

‡All typical values are at $V_{CC} = 5 \text{ V}, T_A = 25^\circ\text{C}$.

§Not more than one output should be shorted at a time and duration of short circuit should not exceed one second.

NOTE 2: With all outputs open and 4.5 V applied to all data and clear inputs, I_{CC} is measured after a momentary ground, then 4.5 V is applied to clock.

switching characteristics, $V_{CC} = 5 \text{ V}, T_A = 25^\circ\text{C}$

PARAMETER	TEST CONDITIONS	MIN	TYP	MAX	UNIT
f_{max} Maximum clock frequency		30	40		MHz
t_{PHL} Propagation delay time, high-to-low-level output from clear	$C_L = 15 \text{ pF}, R_L = 2 \text{ k}\Omega,$ See Note 4		18	27	ns
t_{PLH} Propagation delay time, low-to-high-level output from clock			17	27	ns
t_{PHL} Propagation delay time, high-to-low-level output from clock			18	27	ns

NOTE 4: See General Information Section for load circuits and voltage waveforms.

3
TTL DEVICES

TYPES SN54276, SN74276 QUADRUPLE J-K FLIP-FLOPS

OCTOBER 1976—REVISED DECEMBER 1983

features

- Four J-K Flip-Flops in a Single Package . . . Can Reduce FF Package Count by 50%
- Separate Negative-Edge-Triggered Clocks with Hysteresis . . . Typically 200 mV
- Typical Clock Input Frequency . . . 50 MHz
- Fully Buffered Outputs

description

These quadruple TTL J-K flip-flops incorporate a number of third-generation IC features that can simplify system design and reduce flip-flop package count by up to 50%. They feature hysteresis at each clock input, fully buffered outputs, and direct clear capability, and are presettable through a buffer that also features an input hysteresis loop. The negative-edge-triggering clocks are directly compatible with earlier Series 54/74 single and dual pulse-triggered flip-flops. These circuits can be used to emulate D- or T-type flip-flops by hard-wiring the inputs, or to implement asynchronous sequential functions.

The SN54276 is characterized for operation over the full military temperature range of -55°C to 125°C ; the SN74276 is characterized for operation from 0°C to 70°C .

FUNCTION TABLE (EACH FLIP-FLOP)

COMMON INPUTS		INPUTS			OUTPUT
PRE	CLR	CLK	J	K	Q
L	H	X	X	X	H
H	L	X	X	X	L
L	L	X	X	X	H [†]
H	H	↓	L	H	Q ₀
H	H	↓	H	H	H
H	H	↓	L	L	L
H	H	↓	H	L	TOGGLE
H	H	H	X	X	Q ₀

[†] This configuration is nonstable; that is, it may not persist when preset and clear return to their inactive (high) level.

SN54276 . . . J PACKAGE
SN74276 . . . J OR N PACKAGE

(TOP VIEW)

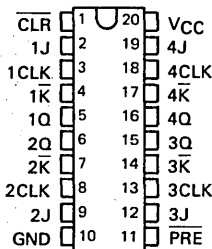

logic symbol†

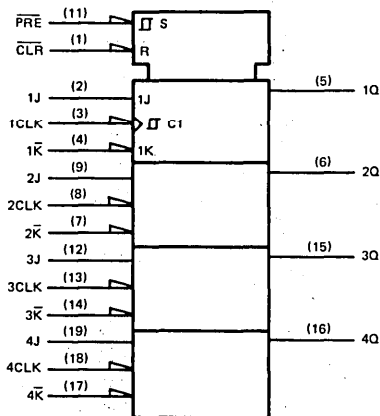

[†] Pin numbers shown on logic symbol are for J and N packages only.

PRODUCTION DATA

This document contains information current as of publication date. Products conform to specifications per the terms of Texas Instruments standard warranty. Production processing does not necessarily include testing of all parameters.



POST OFFICE BOX 225012 • DALLAS, TEXAS 75265

TYPES SN54276, SN74276
 QUADRUPLE J-K FLIP-FLOPS

schematics of inputs and outputs

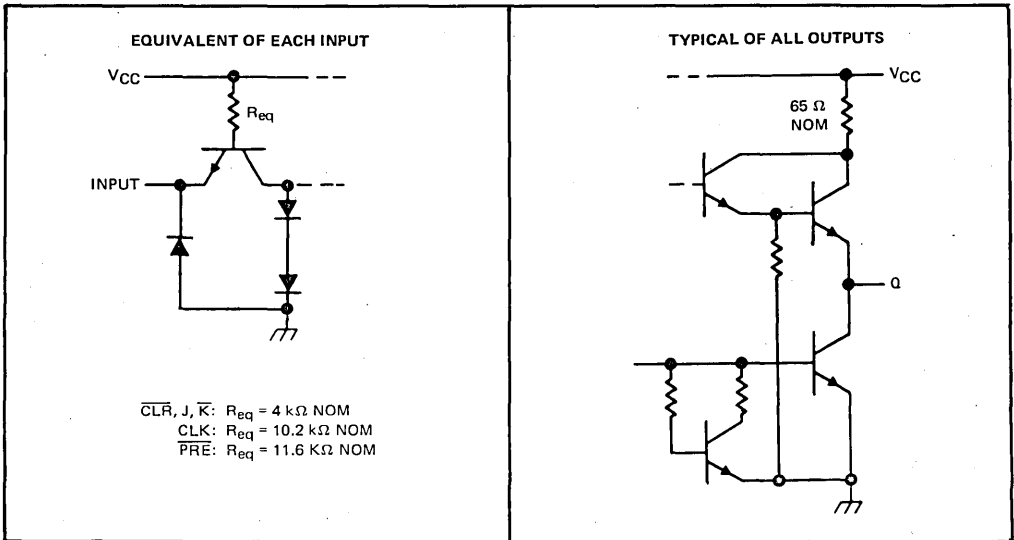

absolute maximum ratings over operating free-air temperature range (unless otherwise noted)

Supply voltage, VCC (see Note 1)	7 V
Input voltage	5.5 V
Operating free-air temperature range: SN54276	-55°C to 125°C
SN74276	0°C to 70°C
Storage temperature range	-65°C to 150°C

NOTE 1: Voltage values are with respect to network ground terminal.

TYPES SN54276, SN74276

QUADRUPLE J-K FLIP-FLOPS

recommended operating conditions

		SN54276			SN74276			UNIT
		MIN	NOM	MAX	MIN	NOM	MAX	
Supply voltage, V_{CC}		4.5	5	5.5	4.75	5	5.25	V
High-level output current, I_{OH}				-800			-800	μ A
Low-level output current, I_{OL}				16			16	mA
Clock frequency			0	35		0	35	MHz
Pulse width, t_w	Clock high	13.5			13.5			ns
	Clock low	15			15			
	Preset or clear low	12			12			
Setup time, t_{su}	J, K inputs	3↓			3↓			ns
	Clear and preset inactive state	10↓			10↓			
Input hold time, t_h		10↓			10↓			ns
Operating free-air temperature, T_A		-55		125	0		70	$^{\circ}$ C

↓ The arrow indicates that the falling edge of the clock pulse is used for reference.

electrical characteristics over recommended operating free-air temperature range (unless otherwise noted)

PARAMETER		TEST CONDITIONS†	MIN	TYP‡	MAX	UNIT
V_{IH}	High-level input voltage		2			V
V_{IL}	Low-level input voltage				0.8	V
V_{IK}	Input clamp voltage	$V_{CC} = \text{MIN}$, $I_I = -12 \text{ mA}$			-1.5	V
V_{OH}	High-level output voltage	$V_{CC} = \text{MIN}$, $V_{IH} = 2 \text{ V}$, $V_{IL} = 0.8 \text{ V}$, $I_{OH} = -800 \mu\text{A}$	2.4	3.4		V
V_{OL}	Low-level output voltage	$V_{CC} = \text{MIN}$, $V_{IH} = 2 \text{ V}$, $V_{IL} = 0.8 \text{ V}$, $I_{OL} = 16 \text{ mA}$		0.2	0.4	V
I_I	Input current at maximum input voltage	$V_{CC} = \text{MAX}$, $V_I = 5.5 \text{ V}$			1	mA
I_{IH}	High-level input current	$V_{CC} = \text{MAX}$, $V_I = 2.4 \text{ V}$			40	μ A
I_{IL}	Low-level input current	$V_{CC} = \text{MAX}$, $V_I = 0.4 \text{ V}$			-1.6	mA
I_{OS}	Short-circuit output current §	$V_{CC} = \text{MAX}$	-30		-85	mA
I_{CC}	Supply current	$V_{CC} = \text{MAX}$		60	81	mA

† For conditions shown as MIN or MAX, use the appropriate value specified under recommended operating conditions.

‡ All typical values are at $V_{CC} = 5 \text{ V}$, $T_A = 25^{\circ}\text{C}$.

§ Not more than one output should be shorted at a time.

switching characteristics, $V_{CC} = 5 \text{ V}$, $T_A = 25^{\circ}\text{C}$

PARAMETER		TEST CONDITIONS	MIN	TYP	MAX	UNIT
f_{max}	Maximum clock frequency		35	50		MHz
t_{PLH}	Propagation delay time, low-to-high-level output from preset	$C_L = 15 \text{ pF}$, $R_L = 400 \Omega$, See Note 2		15	25	ns
t_{PHL}	Propagation delay time, high-to-low-level output from clear			18	30	ns
t_{PLH}	Propagation delay time, low-to-high-level output from clock			17	30	ns
t_{PHL}	Propagation delay time, high-to-low-level output from clock			20	30	ns

NOTE 2: See General Information Section for load circuits and voltage waveforms.

3

TTL DEVICES

TYPES SN54278, SN74278 4-BIT CASCADABLE PRIORITY REGISTERS

MAY 1972—REVISED APRIL 1985

- Latched Data Inputs Serve as Buffer Register and Can also:
 - Synchronize Data Acquisition
 - "Debounce" Mechanical Switch Input
- Cascading Input P0 and Output P1 Provides "Busy" Signal Inhibiting All Lower-Order Bits
- Full TTL Compatibility
- Use for:
 - Priority Interrupt
 - Synchronous Priority Line Selection

SN54278 ... J OR W PACKAGE
SN74278 ... J OR N PACKAGE
(TOP VIEW)

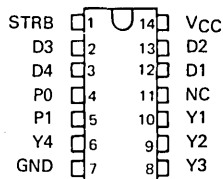

NC—No internal connection

description

The SN54278 and SN74278 each consist of four data latches, full priority output gating, and a cascading gate. The highest-order data applied at a D latch input is transferred to the appropriate Y output while the strobe input is high, and when the strobe goes low all data is latched. The cascading input P0 is fully overriding and on the highest-order package this input must be held at a low logic level. The P1 output is intended for connection to the P0 input of the next lower-order package and will provide a "busy" (high-level) signal to inhibit all subsequent lower-order packages.

After the overriding P0 input, the order of priority is D1, D2, D3, and D4, respectively, within the package.

FUNCTION TABLE

INPUTS		INTERNAL LATCH NODES				OUTPUTS								
P0	G	D1	D2	D3	D4	$\bar{Q}1$	$\bar{Q}2$	$\bar{Q}3$	$\bar{Q}4$	Y1	Y2	Y3	Y4	P1
L	H	H	X	X	X	L	X	X	X	H	L	L	L	H
L	H	L	H	X	X	H	L	X	X	L	H	L	L	H
L	H	L	L	H	X	H	H	L	X	L	L	H	L	H
L	H	L	L	L	H	H	H	H	L	L	L	L	H	H
L	H	L	L	L	L	H	H	H	H	L	L	L	L	L
L	L	X	X	X	X	Latched when G goes low				Same function of \bar{Q} nodes as on 1st 5 lines				
H	L	X	X	X	X					L	L	L	L	H
H	H	Internal \bar{Q} levels are same function of D inputs as on first 5 lines								L	L	L	L	H

H = high level, L = low level, X = irrelevant

logic diagram

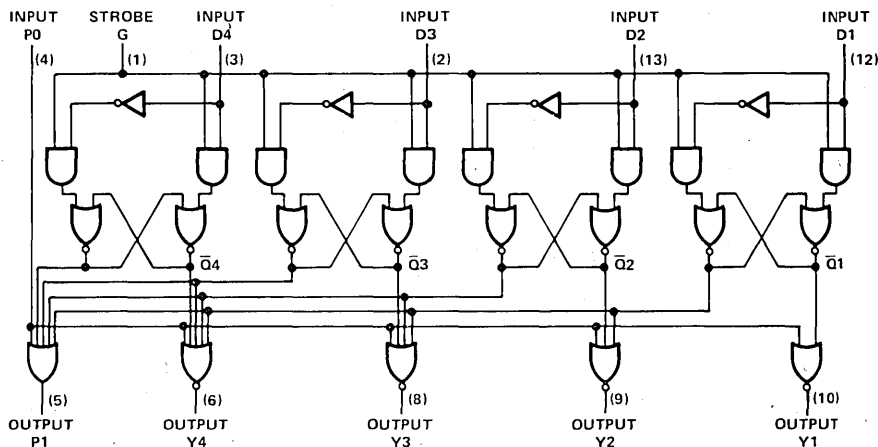

PRODUCTION DATA

This document contains information current as of publication date. Products conform to specifications per the terms of Texas Instruments standard warranty. Production processing does not necessarily include testing of all parameters.

TEXAS
INSTRUMENTS

POST OFFICE BOX 225012 • DALLAS, TEXAS 75265

3-895

3

TTL DEVICES

TYPES SN54278, SN74278

4-BIT CASCADABLE PRIORITY REGISTERS

absolute maximum ratings over operating free-air temperature range (unless otherwise noted)

Supply voltage, V_{CC} (see Note 1)	7 V
Input voltage	5.5 V
Intermitter voltage (see Note 2)	5.5 V
Operating free-air temperature range: SN54278 Circuits	-55°C to 125°C
SN74278 Circuits	0°C to 70°C
Storage temperature range	-65°C to 150°C

- NOTES: 1. Voltage values, except intermitter voltage, are with respect to network ground terminal.
 2. This is the voltage between two emitters of a multiple-emitter transistor. For this circuit, this rating applies between the strobe input and any of the four data inputs.

recommended operating conditions

	SN54278			SN74278			UNIT
	MIN	NOM	MAX	MIN	NOM	MAX	
Supply voltage, V_{CC}	4.5	5	5.5	4.75	5	5.25	V
High-level output current, I_{OH}			-800			-800	μ A
Low-level output current, I_{OL}			16			16	mA
Data setup time, t_{SU} (see Figure 1)	20			20			ns
Data hold time, t_H (see Figure 1)	5			5			ns
Strobe pulse width, t_W (see Figure 1)	20			20			ns
Operating free-air temperature, T_A	-55		125	0		70	°C

electrical characteristics over recommended operating free-air temperature range (unless otherwise noted)

PARAMETER		TEST CONDITIONS†	MIN	TYP	MAX	UNIT
V_{IH}	High-level input voltage		2			V
V_{IL}	Low-level input voltage			0.8		V
V_{IK}	Input clamp voltage	$V_{CC} = \text{MIN}$, $I_I = -12 \text{ mA}$			-1.5	V
V_{OH}	High-level output voltage	$V_{CC} = \text{MIN}$, $V_{IH} = 2 \text{ V}$, $V_{IL} = 0.8 \text{ V}$, $I_{OH} = -800 \mu\text{A}$	2.4	3.4		V
V_{OL}	Low-level output voltage	$V_{CC} = \text{MIN}$, $V_{IH} = 2 \text{ V}$, $V_{IL} = 0.8 \text{ V}$, $I_{OL} = 16 \text{ mA}$		0.2	0.4	V
I_I	Input current at maximum input voltage	$V_{CC} = \text{MAX}$, $V_I = 5.5 \text{ V}$			1	mA
I_{IH}	Any D input	$V_{CC} = \text{MAX}$, $V_I = 2.4 \text{ V}$			80	μ A
	P0 input				200	
	G input				320	
I_{IL}	Any D input	$V_{CC} = \text{MAX}$, $V_I = 0.4 \text{ V}$			-3.2	mA
	P0 input				-8	
	G input				-12.8	
I_{OS}	Short-circuit output current‡	$V_{CC} = \text{MAX}$	SN54278	-18	-55	mA
			SN74278	-18	-57	
I_{CC}	Supply current	$V_{CC} = \text{MAX}$, See Note 3		55	80	mA

† For conditions shown as MIN or MAX, use the appropriate value specified under recommended operating conditions for the applicable type.

‡ All typical values are at $V_{CC} = 5 \text{ V}$, $T_A = 25^\circ \text{C}$.

§ Not more than one output should be shorted at a time.

NOTE 3: I_{CC} is measured with the P0 input grounded, all other inputs at 4.5 V, and outputs open.

3 TTL DEVICES

TYPES SN54278, SN74278 4-BIT CASCADABLE PRIORITY REGISTERS

switching characteristics, $V_{CC} = 5\text{ V}$, $T_A = 25^\circ\text{ C}$

PARAMETER†	FROM (INPUT)	TO (OUTPUT)	WAVEFORMS	TEST CONDITIONS	MIN	TYP	MAX	UNIT
t_{PLH}	Data	Y	A and C (with strobe high)	$C_L = 15\text{ pF}$, $R_L = 400\ \Omega$, See Figure 1			30	ns
t_{PHL}							39	
t_{PLH}	Data	Y	A and D (with strobe high)				38	ns
t_{PHL}							31	
t_{PLH}	Data	P1	A and E (with strobe high)				46	ns
t_{PHL}							39	
t_{PLH}	Strobe	Any Y	B and C or B and D				30	ns
t_{PHL}							31	
t_{PLH}	Strobe	P1	B and E				38	ns
t_{PHL}							42	
t_{PLH}	P0	P1	F and G			23	ns	
t_{PHL}						30		

† t_{PLH} ≡ propagation delay time, low-to-high-level output
 t_{PHL} ≡ propagation delay time, high-to-low-level output

schematics of inputs and outputs

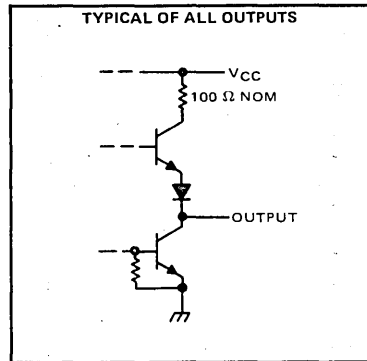
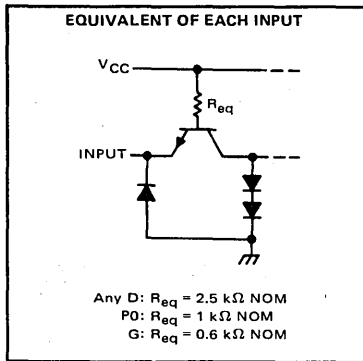

3

TTL DEVICES

TYPES SN54278, SN74278
4-BIT CASCADABLE PRIORITY REGISTERS

PARAMETER MEASUREMENT INFORMATION

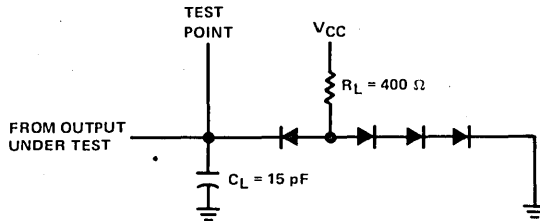

C_L includes probe and jig capacitance.
 All diodes are 1N3064.

LOAD CIRCUIT

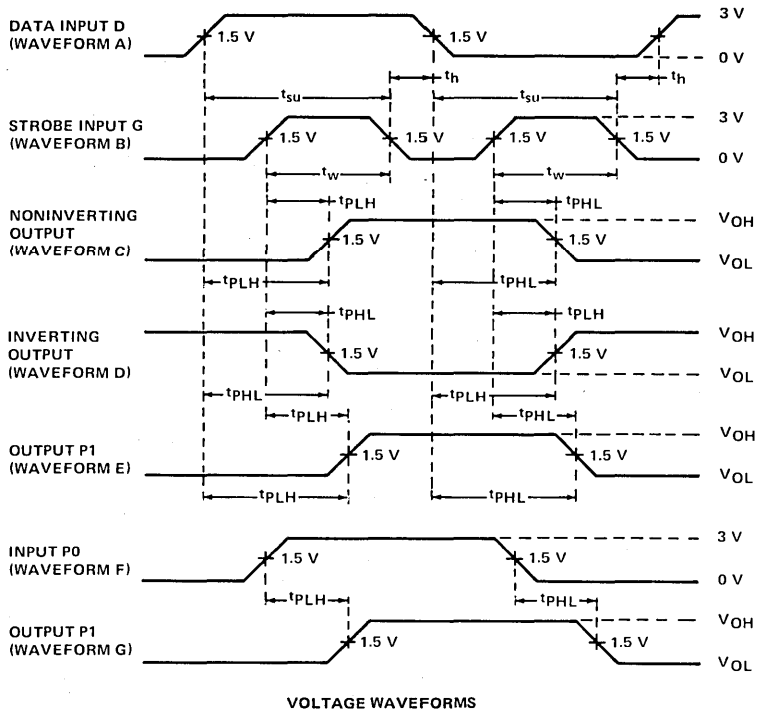

VOLTAGE WAVEFORMS

NOTE: Input pulses are supplied by a generator having the following characteristics: $t_r \leq 7$ ns, $t_f \leq 7$ ns, PRR \leq MHz, $Z_{out} \approx 50\Omega$.

FIGURE 1—SWITCHING TIMES

3 TTL DEVICES

TYPES SN54279, SN54LS279A, SN74279, SN74LS279A QUADRUPLE \bar{S} - \bar{R} LATCHES

REVISED DECEMBER 1983

- Package Options Include Both Plastic and Ceramic Chip Carriers in Addition to Plastic and Ceramic DIPs
- Dependable Texas Instruments Quality and Reliability

description

The '279 offers 4 basic \bar{S} - \bar{R} flip-flop latches in one 16-pin, 300-mil package. Under conventional operation, the \bar{S} - \bar{R} inputs are normally held high. When the \bar{S} input is pulsed low, the Q output will be set high. When \bar{R} is pulsed low, the Q output will be reset low. Normally, the \bar{S} - \bar{R} inputs should not be taken low simultaneously. The Q output will be unpredictable in this condition.

FUNCTION TABLE
(each latch)

INPUTS		OUTPUT
\bar{S} †	\bar{R}	Q
H	H	Q ₀
L	H	H
H	L	L
L	L	H*

H = high level L = low level

Q₀ = the level of Q before the indicated input conditions were established.

*This configuration is nonstable: that is, it may not persist when the \bar{S} and \bar{R} inputs return to their inactive (high) level.

† For latches with double S inputs:

H = both \bar{S} inputs high

L = one or both \bar{S} inputs low

logic diagram

(latches 1 and 3)

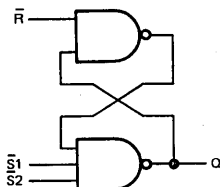

(latches 2 and 4)

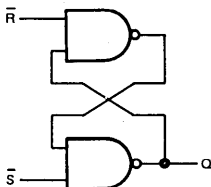

SN54279, SN54LS279A ... J OR W PACKAGE
SN74279 ... J OR N PACKAGE
SN74LS279A ... D, J OR N PACKAGE
(TOP VIEW)

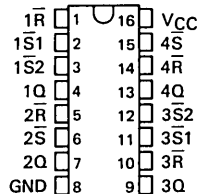

SN54LS279A ... FK PACKAGE
SN74LS279A ... FN PACKAGE
(TOP VIEW)

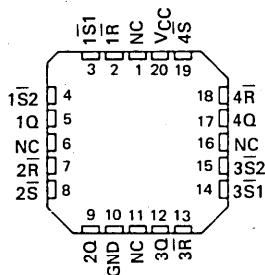

NC - No internal connection

PRODUCTION DATA
This document contains information current as of publication date. Products conform to specifications per the terms of Texas Instruments standard warranty. Production processing does not necessarily include testing of all parameters.

TEXAS
INSTRUMENTS

POST OFFICE BOX 225012 • DALLAS, TEXAS 75265

3-899

TTL DEVICES

TYPES SN54279, SN74279 QUADRUPLE S-R LATCHES

recommended operating conditions

	SN54279			SN74279			UNIT
	MIN	NOM	MAX	MIN	NOM	MAX	
V _{CC} Supply voltage	4.5	5	5.5	4.75	5	5.25	V
V _{IH} High-level input voltage	2			2			V
V _{IL} Low-level input voltage	0.8			0.8			V
I _{OH} High-level output current	-0.8			-0.8			mA
I _{OL} Low-level output current	16			16			mA
t _w Pulse duration, low	20			20			ns
T _A Operating free-air temperature	-55			125			°C

electrical characteristics over recommended operating free-air temperature range (unless otherwise noted)

PARAMETER	TEST CONDITIONS [†]	SN54279			SN74279			UNIT
		MIN	TYP [‡]	MAX	MIN	TYP [‡]	MAX	
V _{IK}	V _{CC} = MIN, I _I = -12 mA	-1.5			-1.5			V
V _{OH}	V _{CC} = MIN, V _{IL} = 0.8 V, I _{OH} = -0.8 mA	2.4	3.4		2.4	3.4	V	
V _{OL}	V _{CC} = MIN, V _{IH} = 2 V, I _{OL} = 16 mA	0.2	0.4		0.2	0.4	V	
I _I	V _{CC} = MAX, V _I = 5.5 V	1			1			mA
I _{IH}	V _{CC} = MAX, V _I = 2.4 V	40			40			μA
I _{IL}	V _{CC} = MAX, V _I = 0.4 V	-1.6			-1.6			mA
I _{OS} [§]	V _{CC} = MAX	-18	-55		-18	-57	mA	
I _{CC}	V _{CC} = MAX, See Note 2	18	30		18	30	mA	

[†] For conditions shown as MIN or MAX, use the appropriate value specified under recommended operating conditions.

[‡] All typical values are at V_{CC} = 5 V, T_A = 25°C.

[§] Not more than one output should be shorted at a time.

NOTE 2: I_{CC} is measured with all R inputs grounded, all S inputs at 4.5 V, and all outputs open.

switching characteristics, V_{CC} = 5 V, T_A = 25°C (see note 3)

PARAMETER	FROM (INPUT)	TO (OUTPUT)	TEST CONDITIONS		MIN	TYP	MAX	UNIT
^t PLH	S	Q	R _L = 400 Ω,	C _L = 15 pF	12	22	ns	
^t PHL					9	15		
^t PHL	R	Q			15	27		ns

NOTE 3: See General Information Section for load circuits and voltage waveforms.

3

TTL DEVICES

**TYPES SN54LS279A, SN74LS279A
QUADRUPLE S-R LATCHES**

recommended operating conditions

	SN54LS279A			SN74LS279A			UNIT
	MIN	NOM	MAX	MIN	NOM	MAX	
V _{CC} Supply voltage	4.5	5	5.5	4.75	5	5.25	V
V _{IH} High-level input voltage	2			2			V
V _{IL} Low-level input voltage			0.7			0.8	V
I _{OH} High-level output current			-0.4			-0.4	mA
I _{OL} Low-level output current			4			8	mA
t _w Pulse duration, low	20			20			ns
T _A Operating free-air temperature	-55	125		0	70		°C

electrical characteristics over recommended operating free-air temperature range (unless otherwise noted)

PARAMETER	TEST CONDITIONS†	SN54LS279A		SN74LS279A		UNIT		
		MIN	TYP‡	MAX	MIN		TYP‡	MAX
V _{IK}	V _{CC} = MIN, I _I = -18 mA			-1.5		-1.5	V	
V _{OH}	V _{CC} = MIN, V _{IL} = MAX, I _{OH} = -0.4 mA	2.5	3.4		2.7	3.4	V	
V _{OL}	V _{CC} = MIN, V _{IH} = 2 V, I _{OL} = 4 mA		0.25	0.4		0.25	0.4	V
	V _{CC} = MIN, V _{IH} = 2 V, I _{OL} = 8 mA					0.25	0.5	
I _I	V _{CC} = MAX, V _I = 7 V			0.1			0.1	mA
I _{IH}	V _{CC} = MAX, V _I = 2.7 V			20			20	μA
I _{IL}	V _{CC} = MAX, V _I = 0.4 V			-0.2			-0.2	mA
I _{OS} §	V _{CC} = MAX	-20		-100	-20		-100	mA
I _{CC}	V _{CC} = MAX, See note 2		3.8	7		3.8	7	mA

† For conditions shown as MIN or MAX, use the appropriate value specified under recommended operating conditions.

‡ All typical values are at V_{CC} = 5 V, T_A = 25°C.

§ Not more than one output should be shorted at a time, and the duration of the short-circuit should be less than one second.

NOTE 2: I_{CC} is measured with all R inputs grounded, all S inputs at 4.5 V, and all outputs open.

switching characteristics, V_{CC} = 5 V, T_A = 25°C (see note 3)

PARAMETER	FROM (INPUT)	TO (OUTPUT)	TEST CONDITIONS	MIN	TYP	MAX	UNIT
t _{PLH}	S	Q	R _L = 2 kΩ, C _L = 15 pF		12	22	ns
t _{PHL}					13	21	
t _{PHL}	R	Q			15	27	ns

NOTE 3: See General Information Section for load circuits and voltage waveforms.

3 TTL DEVICES

TYPES SN54LS280, SN54S280, SN74LS280, SN74S280 9-BIT ODD/EVEN PARITY GENERATORS/CHECKERS

DECEMBER 1972—REVISED DECEMBER 1983

- Generates Either Odd or Even Parity for Nine Data Lines
- Cascadable for n-Bits
- Can Be Used to Upgrade Existing Systems using MSI Parity Circuits
- Typical Data-to-Output Delay of Only 14 ns for 'S280 and 33 ns for 'LS280
- Typical Power Dissipation:
'LS280 . . . 80 mW
'S280 . . . 335 mW

SN54LS280, SN54S280 . . . J OR W PACKAGE
SN74LS280, SN74S280 . . . D, J OR N PACKAGE

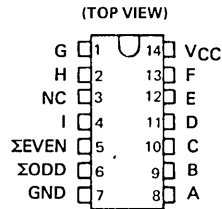

SN54LS280, SN54S280 . . . FK PACKAGE
SN74LS280, SN74S280 . . . FN PACKAGE

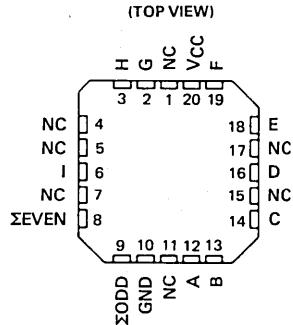

NC - No internal connection

FUNCTION TABLE

NUMBER OF INPUTS A THRU I THAT ARE HIGH	OUTPUTS	
	Σ EVEN	Σ ODD
0, 2, 4, 6, 8	H	L
1, 3, 5, 7, 9	L	H

H = high level, L = low level

description

These universal, monolithic, nine-bit parity generators/checkers utilize Schottky-clamped TTL high-performance circuitry and feature odd/even outputs to facilitate operation of either odd or even parity application. The word-length capability is easily expanded by cascading as shown under typical application data.

Series 54LS/74LS and Series 54S/74S parity generators/checkers offer the designer a trade-off between reduced power consumption and high performance. These devices can be used to upgrade the performance of most systems utilizing the '180 parity generator/checker. Although the 'LS280 and 'S280 are implemented without expander inputs, the corresponding function is provided by the availability of an input at pin 4 and the absence of any internal connection at pin 3. This permits the 'LS280 and 'S280 to be substituted for the '180 in existing designs to produce an identical function even if 'LS280's and 'S280's are mixed with existing '180's.

These devices are fully compatible with most other TTL circuits. All 'LS280 and 'S280 inputs are buffered to lower the drive requirements to one Series 54LS/74LS or Series 54S/74S standard load, respectively.

PRODUCTION DATA
This document contains information current as of publication date. Products conform to specifications per the terms of Texas Instruments standard warranty. Production processing does not necessarily include testing of all parameters.

TEXAS
INSTRUMENTS

POST OFFICE BOX 225012 • DALLAS, TEXAS 75265

3-903



TTL DEVICES

TYPES SN54S280, SN74S280 9-BIT ODD/EVEN PARITY GENERATORS/CHECKERS

schematics of inputs and outputs

'LS280

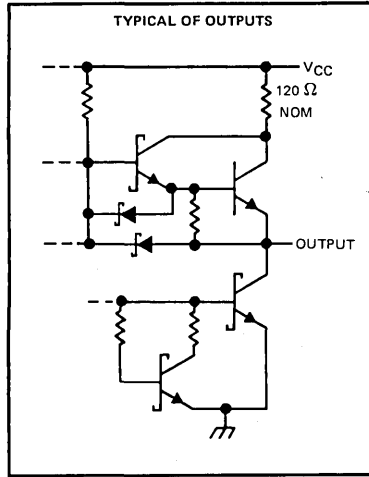
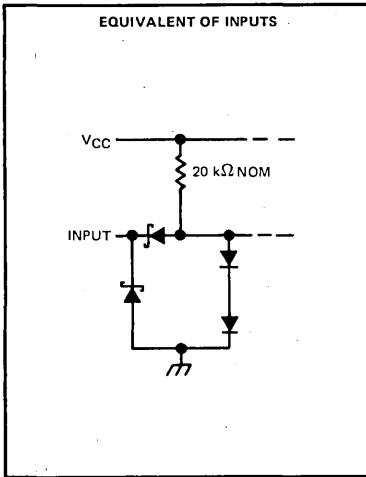

'S280

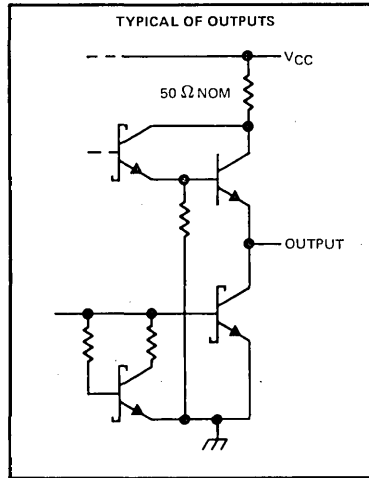
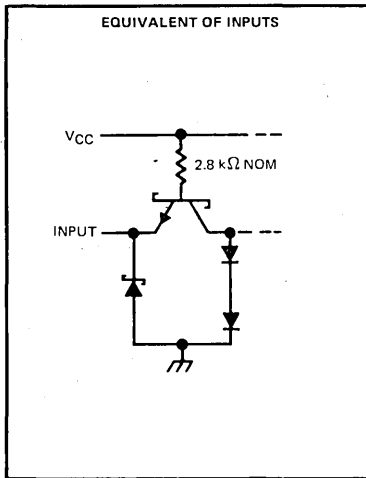

absolute maximum ratings over operating free-air temperature range (unless otherwise noted)

Supply voltage (see Note 1)	7 V
Input voltage: 'LS280	7 V
'S280	5.5 V
Operating free-air temperature range: SN54'	-55°C to 125°C
SN74'	0°C to 70°C
Storage temperature range	-65°C to 150°C

NOTE 1: Voltage values are with respect to network ground terminal.

3 TTL DEVICES

TYPES SN54LS280, SN74LS280

9-BIT ODD/EVEN PARITY GENERATORS/CHECKERS

recommended operating conditions

	SN54LS280			SN74LS280			UNIT
	MIN	NOM	MAX	MIN	NOM	MAX	
V _{CC} Supply voltage	4.5	5	5.5	4.75	5	5.25	V
V _{IH} High-level input voltage	2			2			V
V _{IL} Low-level input voltage			0.7			0.8	V
I _{OH} High-level output current			-0.4			-0.4	mA
I _{OL} Low-level output current			4			8	mA
T _A Operating free-air temperature	-55		125	0		70	°C

electrical characteristics over recommended operating free-air temperature range (unless otherwise noted)

PARAMETER	TEST CONDITIONS	SN54LS280			SN74LS280			UNIT
		MIN	TYP†	MAX	MIN	TYP†	MAX	
V _{IK}	V _{CC} = MIN, I _I = -18 mA			-1.5			-1.5	V
V _{OH}	V _{CC} = MIN, V _{IH} = 2 V, V _{IL} = MAX, I _{OH} = -0.4 mA	2.5	3.4		2.7	3.4		V
V _{OL}	V _{CC} = MIN, V _{IH} = 2 V, V _{IL} = MAX		0.25	0.4		0.25	0.4	V
	I _{OL} = 4 mA					0.35	0.5	
I _I	V _{CC} = MAX, V _I = 7 V			0.1			0.1	mA
I _{IH}	V _{CC} = MAX, V _I = 2.7 V			20			20	μA
I _{IL}	V _{CC} = MAX, V _I = 0.4 V			-0.4			-0.4	mA
I _{OS} §	V _{CC} = MAX	-20		-100	-20		-100	mA
I _{CC}	V _{CC} = MAX, See Note 2		16	27		16	27	mA

† For conditions shown as MIN or MAX, use the appropriate value specified under recommended operating conditions.

‡ All typical values are at V_{CC} = 5 V, T_A = 25°C.

§ Not more than one output should be shorted at a time and duration of the short circuit should not exceed one second.

NOTE 2: I_{CC} is measured with all inputs grounded and all outputs open.

switching characteristics, V_{CC} = 5 V, T_A = 25°C

PARAMETER¶	FROM (INPUT)	TO (OUTPUT)	TEST CONDITIONS	MIN	TYP	MAX	UNIT
t _{PLH}	Data	Σ Even	C _L = 15 pF, R _L = 2 kΩ, Inputs not under test at 0 V, See Note 3		33	50	ns
t _{PHL}					29	45	
t _{PLH}	Data	Σ Odd			23	35	ns
t _{PHL}					31	50	

¶ t_{PLH} = propagation delay time, low-to-high-level output; t_{PHL} = propagation delay time, high-to-low-level output

NOTE 3: See General Information Section for load circuits and voltage waveforms.

3

TTL DEVICES

TYPES SN54S280, SN74S280 9-BIT ODD/EVEN PARITY GENERATORS/CHECKERS

recommended operating conditions

	SN54S280			SN74S280			UNIT
	MIN	NOM	MAX	MIN	NOM	MAX	
Supply voltage, V_{CC}	4.5	5	5.5	4.75	5	5.25	V
High-level output current, I_{OH}			-1			-1	mA
Low-level output current, I_{OL}			20			20	mA
Operating free-air temperature, T_A	-55		125	0		70	°C

electrical characteristics over recommended operating free-air temperature range (unless otherwise noted)

PARAMETER	TEST CONDITIONS†	MIN	TYP‡	MAX	UNIT
V_{IH} High-level input voltage		2			V
V_{IL} Low-level input voltage				0.8	V
V_{IK} Input clamp voltage	$V_{CC} = \text{MIN}, I_I = -18 \text{ mA}$			-1.2	V
V_{OH} High-level output voltage	$V_{CC} = \text{MIN}, V_{IH} = 2 \text{ V},$ $V_{IL} = 0.8 \text{ V}, I_{OH} = -1 \text{ mA}$	SN54S*	2.5	3.4	V
		SN74S*	2.7	3.4	
V_{OL} Low-level output voltage	$V_{CC} = \text{MIN}, V_{IH} = 2 \text{ V},$ $V_{IL} = 0.8 \text{ V}, I_{OL} = 20 \text{ mA}$			0.5	V
I_I Input current at maximum input voltage	$V_{CC} = \text{MAX}, V_I = 5.5 \text{ V}$			1	mA
I_{IH} High-level input current	$V_{CC} = \text{MAX}, V_I = 2.7 \text{ V}$			50	µA
I_{IL} Low-level input current	$V_{CC} = \text{MAX}, V_I = 0.5 \text{ V}$			-2	mA
I_{OS} Short-circuit output current§	$V_{CC} = \text{MAX}$		-40	-100	mA
I_{CC} Supply current	$V_{CC} = \text{MAX}, \text{ See Note 2}$	SN54S280	67	99	mA
		SN74S280	67	105	
	$V_{CC} = \text{MAX}, T_A = 125^\circ \text{C},$ See Note 2	SN54S280N		94	mA

† For conditions shown as MIN or MAX, use the appropriate value specified under recommended operating conditions.

‡ All typical values are at $V_{CC} = 5 \text{ V}, T_A = 25^\circ \text{C}$.

§ Not more than one output should be shorted at a time and duration of the short circuit should not exceed one second.

NOTE 2: I_{CC} is measured with all inputs grounded and all outputs open.

switching characteristics, $V_{CC} = 5 \text{ V}, T_A = 25^\circ \text{C}$

PARAMETER¶	FROM (INPUT)	TO (OUTPUT)	TEST CONDITIONS	MIN	TYP	MAX	UNIT
t_{PLH}	Data	Σ Even	$C_L = 15 \text{ pF}, R_L = 280 \Omega,$ See Note 3		14	21	ns
t_{PHL}					11.5	18	
t_{PLH}	Data	Σ Odd			14	21	ns
t_{PHL}					11.5	18	

¶ t_{PLH} = propagation delay time, low-to-high-level output; t_{PHL} = propagation delay time, high-to-low-level output

NOTE 3: See General Information Section for load circuits and voltage waveforms.

3

TTL DEVICES

TYPES SN54LS280, SN54S280, SN74LS280, SN74S280 9-BIT ODD/EVEN PARITY GENERATORS/CHECKERS

logic diagram

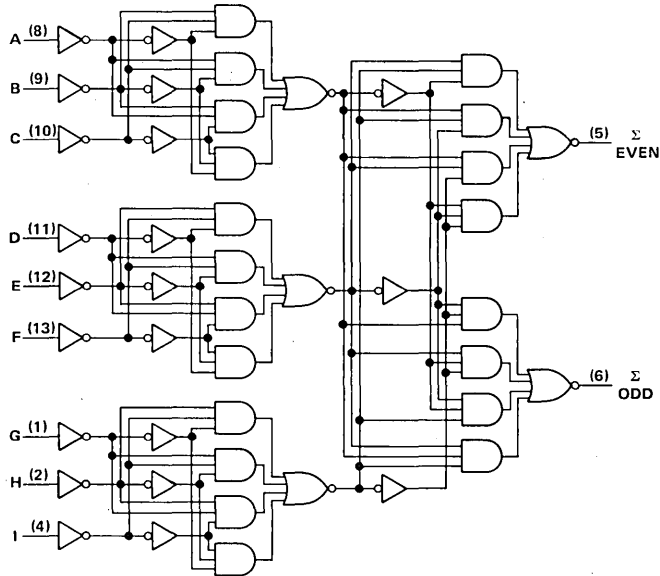

Pin numbers shown on logic notation are for D, J or N packages.

TYPICAL APPLICATION DATA

25-LINE PARITY/GENERATOR CHECKER

Three 'LS280's or 'S280's can be used to implement a 25-line parity generator/checker. This arrangement will provide parity in typically 75 or 25 nanoseconds respectively.

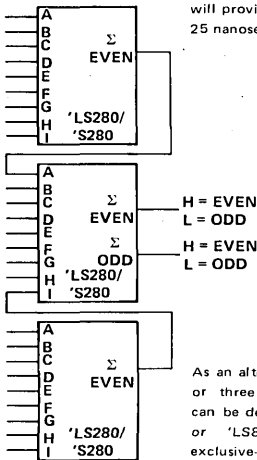

As an alternative, the outputs of two or three parity generators/checkers can be decoded with a 2-input ('S86 or 'LS86) or 3-input ('S135) exclusive-OR gate for 18- or 27-line parity applications.

81-LINE PARITY/GENERATOR CHECKER

Longer word lengths can be implemented by cascading 'LS280's or 'S280's. As shown here, parity can be generated for word lengths up to 81 bits in typically 75 or 25 nanoseconds respectively.

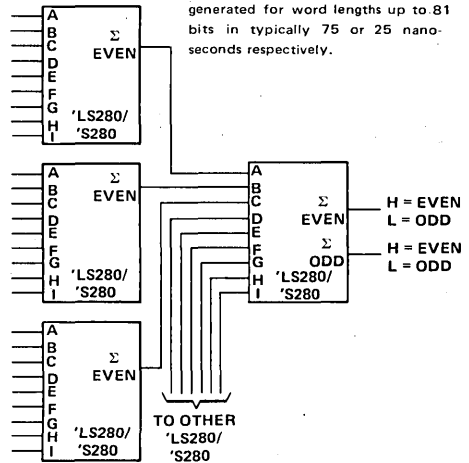

3

TTL DEVICES

TEXAS
INSTRUMENTS

POST OFFICE BOX 225012 • DALLAS, TEXAS 75265

3-907



TTL DEVICES

TYPES SN54S281, SN74S281 4-BIT PARALLEL BINARY ACCUMULATORS

FEBRUARY 1974—REVISED DECEMBER 1983

- Full 4-Bit Binary Accumulator in a Single Package
- 15 Arithmetic/Logic-Type Operations:
 - Add
 - Subtract (B-A or A-B)
 - Complement
 - Increment
 - Transfer
 - Plus 10 Other Functions
- Full Shifting Capabilities:
 - Logic Shift (Left or Right)
 - Arithmetic Shift (Left or Right) for Sign Bit Protection
 - Hold
 - Parallel Load
- Expandable to Handle n-Bit Words with Full Carry Look-Ahead
- Logic Mode Operation Provides Seven Boolean Functions of the Two Variables

description

These Schottky-clamped four-bit accumulators integrate high-performance versions of an arithmetic logic unit/function generator and a shift/storage matrix on a single monolithic circuit bar. The arithmetic logic unit (ALU) portion, similar to the SN54S181/SN74S181 circuit, incorporates the capability to perform 16 arithmetic/logic-type operations as detailed in Table 1.

The accumulator includes an exchange of subtract operands by which either A-B or B-A can be accomplished directly. The ALU is controlled by three function-select inputs (AS0, AS1, AS2) and a mode-control input (M). When the mode-control input is high, the ALU is placed in a logic mode that performs any of seven logic functions on two binary variables as detailed in Table 2. Full carry look-ahead is provided for fast, simultaneous carry generation for the full four binary bits. The carry input (C_n) and propagate and generate outputs (P, G) are implemented for direct use with the SN54S182/SN74S182 look-ahead carry generators. This permits systems to be implemented with the added advantage of full look-ahead across any word length to minimize the accumulator delay times. Once data is loaded into the accumulator, the typical add time with full look-ahead is 29 nanoseconds for 16-bit words.

The shift/storage matrix is analogous in its capabilities to the SN54S194/SN74S194 universal bidirectional shift register with the added advantages of multiplexed input/output (I/O) cascading lines that comprehend arithmetic shift functions having a sign bit, such as 2's complements. The matrix can be used to perform either logic or arithmetic shifts in either direction (left or right), parallel load, or hold. Control of the register is accomplished with three inputs: register control (RC) and register selection (RS0, RS1). The cascading input/output lines incorporate three-state outputs multiplexed with an input. The least-significant cascading bit is combined with the A0, F0 circuitry to provide the shift-right input and the shift-left output (RI/LO), and the most significant bit is coupled with the A3, F3 circuitry to provide the shift-left input and the shift-right output (LI/RO).

Series 54S circuits are characterized for operation over the full military temperature range of -55°C to 125°C ; Series 74S circuits are characterized for operation from 0°C to 70°C .

SN54S281 . . . J OR W PACKAGE
SN74S281 . . . DW, J OR N PACKAGE
(TOP VIEW)

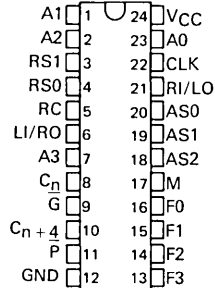

SN54S281 . . . FK PACKAGE
SN74S281 . . . FN PACKAGE
(TOP VIEW)

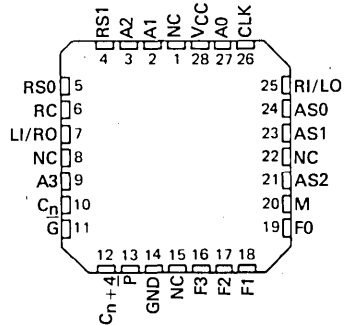

NC - No internal connection

PRODUCTION DATA
This document contains information current as of publication date. Products conform to these specifications per the terms of Texas Instruments standard warranty. Production processing does not necessarily include testing of all parameters.

**TEXAS
INSTRUMENTS**

POST OFFICE BOX 225012 • DALLAS, TEXAS 75265

3-909

TTL DEVICES

3

TYPES SN54S281, SN74S281
4-BIT PARALLEL BINARY ACCUMULATORS

logic symbol

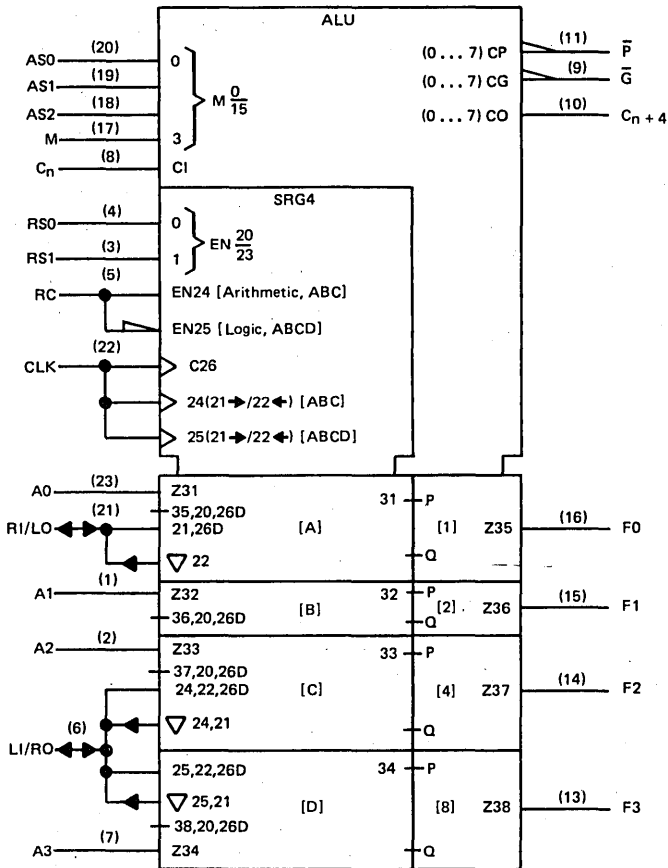

Pin numbers shown on logic notation are for DW, J or N packages.

3

TTL DEVICES

TYPES SN54S281, SN74S281
4-BIT PARALLEL BINARY ACCUMULATORS

logic diagram

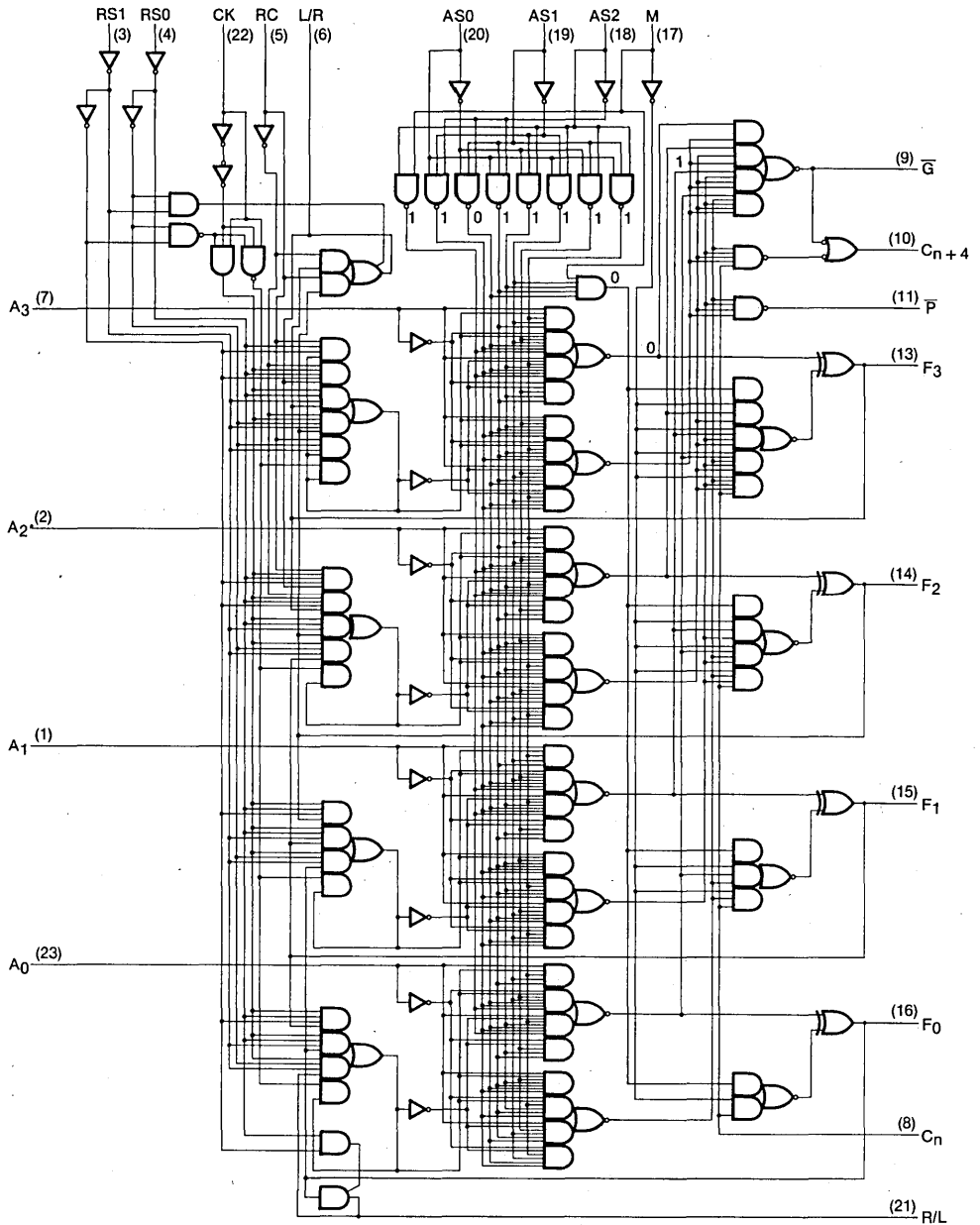

TYPES SN54S281, SN74S281 4-BIT PARALLEL BINARY ACCUMULATORS

FUNCTION TABLES

TABLE 1—ARITHMETIC FUNCTIONS

Mode Control (M) = Low

ALU SELECTION			ACTIVE-HIGH DATA			
AS2	AS1	AS0	C _n = H (with carry)		C _n = L (no carry)	
L	L	L	F ₀ = L, F ₁ = F ₂ = F ₃ = H			F _n = H
L	L	H	F = B MINUS A			F = B MINUS A MINUS 1
L	H	L	F = A MINUS B			F = A MINUS B MINUS 1
L	H	H	F = A PLUS B PLUS 1			F = A PLUS B
H	L	L	F = B PLUS 1			F _n = B _n
H	L	H	F = \bar{B} PLUS 1			F _n = \bar{B}_n
H	H	L	F = A PLUS 1			F _n = A _n
H	H	H	F = \bar{A} PLUS 1			F _n = \bar{A}_n

TABLE 2—LOGIC FUNCTIONS

Mode Control (M) = High

Carry Input (C_n) = X (Irrelevant)

ALU SELECTION			ACTIVE-HIGH DATA FUNCTION			
AS2	AS1	AS0	DATA FUNCTION			
L	L	L	F _n = L			
L	X	H	F _n = A _n ⊕ B _n			
L	H	L	F _n = A _n ⊕ B _n			
H	L	L	F _n = A _n B _n			
H	L	H	F _n = A _n + B _n			
H	H	L	F _n = $\overline{A_n B_n}$			
H	H	H	F _n = A _n + B _n			

TABLE 3—SHIFT-MODE FUNCTIONS
C_n = M = AS0 = AS1 = L, and AS2 = H (F_n = B_n)

FUNCTION	INPUTS BEFORE †										CLOCK INPUT	OUTPUTS AFTER †					
	REGISTER SELECTION RS0 RS1		REGISTER CONTROL INPUT	INPUT/OUTPUT RI/LO	SHIFT-MATRIX INPUTS F0 F1 F2 F3				INPUT/OUTPUT LI/RO	INPUT/OUTPUT RI/LO		SHIFT-MATRIX OUTPUTS (ALU B INPUTS) Q _A Q _B Q _C Q _D				INPUT/OUTPUT LI/RO	
	L	H	X	Z	f0	f1	f2	f3	Z			†	Z	f0	f1		f2
LOAD	L	L	X	Z	f0	f1	f2	f3	Z	†	Z	f0	f1	f2	f3	Z	
LSL	L	H	L	Q _A	Q _A	Q _B	Q _C	Q _D	li	†	Q _{Bn}	Q _{Bn}	Q _{Cn}	Q _{Dn}	li	li	
LSA	L	H	H	Q _A	Q _A	Q _B	Q _C	Q _D	li	†	Q _{Bn}	Q _{Bn}	Q _{Cn}	li	Q _{D0}	li	
RSL	H	L	L	ri	Q _A	Q _B	Q _C	Q _D	Q _D	†	ri	ri	Q _{An}	Q _{Bn}	Q _{Cn}	Q _{Cn}	
RSA	H	L	H	ri	Q _A	Q _B	Q _C	Q _D	Q _C	†	ri	ri	Q _{An}	Q _{Bn}	Q _{D0}	Q _{Bn}	
HOLD	H	H	X	X	Q _A	Q _B	Q _C	Q _D	X	†	Z	Q _{A0}	Q _{B0}	Q _{C0}	Q _{D0}	Z	
	X	X	X	X	Q _A	Q _B	Q _C	Q _D	X	L	RI/LO	Q _{A0}	Q _{B0}	Q _{C0}	Q _{D0}	LI/RO	

H = high level (steady state)

L = low level (steady state)

X = irrelevant (any input, including transitions)

Z = high impedance (output off)

† = transition from low to high level

f0, f1, f2, f3, ri, li = the level of steady-state conditions at F0, F1, F2, F3, RI/LO, or LI/RO respectively

Q_{A0}, Q_{B0}, Q_{C0}, Q_{D0} = the level of Q_A, Q_B, Q_C, or Q_D, respectively, before the indicated steady-state input conditions were established

Q_{An}, Q_{Bn}, Q_{Cn}, Q_{Dn} = the level of Q_A, Q_B, Q_C, or Q_D, respectively, before the most recent transition of the clock

absolute maximum ratings over operating free-air temperature range (unless otherwise noted)

Supply voltage, V _{CC} (see Note 1)	7 V
Input voltage	5.5 V
Operating free-air temperature range: SN54S281 (see Note 2)	-55°C to 125°C
SN74S281	0°C to 70°C
Storage temperature range	-65°C to 150°C

NOTES: 1. Voltage values are with respect to network ground terminal.

2. An SN54S281 in the W package operating at free-air temperatures above 110°C requires a heat sink that provides thermal resistance from case to free-air, R_{θCA}, of not more than 20°C/W.

TTL DEVICES

TYPES SN54S281, SN74S281

4-BIT PARALLEL BINARY ACCUMULATORS

recommended operating conditions

		SN54S281			SN74S281			UNIT
		MIN	NOM	MAX	MIN	NOM	MAX	
Supply voltage, V_{CC}		4.5	5	5.5	4.75	5	5.25	V
High-level output current, I_{OH}	Any output except LI/RO and RI/LO	-1			-1			mA
	LI/RO and RI/LO	-2			-2			
Low-level output current, I_{OL}	Any output except LI/RO and RI/LO	20			20			mA
	LI/RO and RI/LO	10			10			
Clock frequency, f_{clock} (for shifting)		0	50		0	50		MHz
Width of clock pulse, $t_w(\text{clock})$		8			8			ns
Data setup time with respect to clock, t_{su}		0†			0†			ns
Data hold time with respect to clock, t_h		18†			18†			ns
Operating free-air temperature, T_A (see Note 2)		-55		125	0	70		°C

† The arrow indicates that the rising edge of the clock pulse is used for reference.

NOTE 2: An SN54S281 in the W package operating at free-air temperatures above 110°C requires a heat sink that provides thermal resistance from case to free-air, $R_{\theta CA}$, of not more than 20°C/W.

electrical characteristics over recommended operating free-air temperature range (unless otherwise noted)

PARAMETER		TEST CONDITIONS†	SN54S281			SN74S281			UNIT
			MIN	TYP‡	MAX	MIN	TYP‡	MAX	
V_{IH}	High-level input voltage		2			2			V
V_{IL}	Low-level input voltage		0.8			0.8			V
V_{IK}	Input clamp voltage	Any input except LI/RO and RI/LO $V_{CC} = \text{MIN}, I_I = -18 \text{ mA}$	-1.2			-1.2			V
V_{OH}	High-level output voltage	Any output except LI/RO and RI/LO $V_{CC} = \text{MIN}, V_{IH} = 2 \text{ V},$	2.5	3.4		2.7	3.4		V
		LI/RO, RI/LO $V_{IL} = 0.8 \text{ V}, I_{OH} = \text{MAX}$	2.4	3.4		2.4	3.4		
V_{OL}	Low-level output voltage	$V_{CC} = \text{MIN}, V_{IH} = 2 \text{ V},$ $V_{IL} = 0.8 \text{ V}, I_{OL} = \text{MAX}$	0.5			0.5			V
I_I	Input current at maximum input voltage	$V_{CC} = \text{MAX}, V_I = 5.5 \text{ V}$	1			1			mA
I_{IH}	High-level input current	RS0, RS1	50			50			μA
		M, Clock	150			150			
		LI/RO, RI/LO	200			200			
		AS2	300			300			
		All others	250			250			
I_{IL}	Low-level input current	RS0, RS1, LI/RO	-2			-2			mA
		RI/LO	-3			-3			
		M, Clock	-4			-4			
		AS0, AS1	-6			-6			
		All others	-8			-8			
I_{OS}	Short-circuit output current §	$V_{CC} = \text{MAX}$	-40	-110	-40	-110		mA	
I_{CC}	Supply current	$V_{CC} = \text{MAX},$ $T_A = 125^\circ\text{C}$ W package only	190						mA
		$V_{CC} = \text{MAX}$ All packages	144	230	144	230			

† For conditions shown as MIN or MAX, use the appropriate value specified under recommended operating conditions.

‡ All typical values are at $V_{CC} = 5 \text{ V}, T_A = 25^\circ\text{C}$.

§ Not more than one output should be shorted at a time and duration of the short-circuit should not exceed one second.

NOTE 3. When testing input current at the RI/LO or LI/RO terminals, the output under test must be in the high-impedance (off) state.

3

TTL DEVICES

TYPES SN54S281, SN74S281 4-BIT PARALLEL BINARY ACCUMULATORS

switching characteristics, $V_{CC} = 5\text{ V}$, $T_A = 25^\circ\text{C}$

PARAMETER [¶]	FROM (INPUT)	TO (OUTPUT)	TEST CONDITIONS	MIN	TYP	MAX	UNIT
t_{PLH}	C_n	C_{n+4}	$C_L = 15\text{ pF}$, I/O outputs: $R_L = 560\ \Omega$, Other outputs: $R_L = 280\ \Omega$, See Figure 1	10	20	ns	
t_{PHL}				10	20		
t_{PLH}	Any A	C_{n+4}		18	30	ns	
t_{PHL}				18	30		
t_{PLH}	C_n	Any F		10	20	ns	
t_{PHL}				10	20		
t_{PLH}	Any A	\overline{G}		14	24	ns	
t_{PHL}				14	24		
t_{PLH}	Any A	\overline{P}		12	20	ns	
t_{PHL}				12	20		
t_{PLH}	A_i	F_i		20	35	ns	
t_{PHL}				20	35		
t_{PLH}	A_0	RI/LO		30	45	ns	
t_{PHL}				30	45		
t_{PLH}	A_3	LI/RO		30	45	ns	
t_{PHL}				30	45		
t_{PLH}	F_0	RI/LO		7	11	ns	
t_{PHL}				7	11		
t_{PLH}	F_3	LI/RO		7	11	ns	
t_{PHL}				7	11		
t_{PLH}	Any AS	Any F or C_{n+4}	28	45	ns		
t_{PHL}			28	45			
t_{PLH}	Any AS	\overline{P} or \overline{G}	20	33	ns		
t_{PHL}			20	33			
t_{PLH}	Clock	Any F	30	45	ns		
t_{PHL}			30	45			
t_{PLH}	Clock	RI/LO or LI/RO	35	55	ns		
t_{PHL}			35	55			

[¶] t_{PLH} Propagation delay time, low-to-high level output
[¶] t_{PHL} Propagation delay time, high-to-low level output

PARAMETER MEASUREMENT INFORMATION

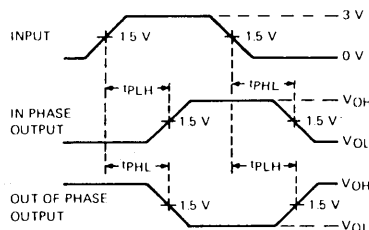
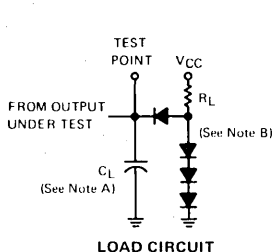

NOTES: A. Input pulse is supplied by a generator having the following characteristics: $t_r \leq 2.5\text{ ns}$, $t_f \leq 2.5\text{ ns}$, $PRR \leq 1\text{ MHz}$, $Z_{out} \approx 50\ \Omega$.
 B. C_L includes probe and jig capacitance.
 C. All diodes are 1N3064 or equivalent.

FIGURE 1

TYPES SN54S281, SN74S281 4-BIT PARALLEL BINARY ACCUMULATORS

TYPICAL APPLICATION DATA

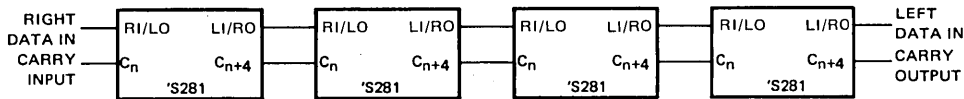

ENTER AND STORE TIME: 38 ns typical
EACH SUCCESSIVE ADDITION TO STORED DATA: 44 ns typical

FIGURE A—16-BIT BINARY ACCUMULATOR USING FOUR SN54S281/SN74S281 CIRCUITS IN RIPPLE-CARRY MODE

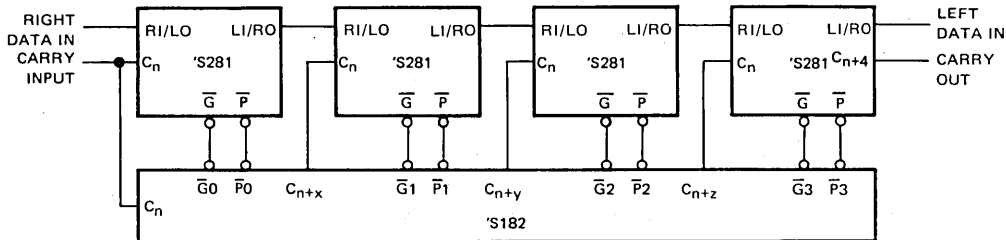

ENTER AND STORE TIME: 37 ns typical
EACH SUCCESSIVE ADDITION TO STORED DATA: 29 ns typical

FIGURE B—16-BIT BINARY ACCUMULATOR USING FOUR SN54S281/SN74S281 CIRCUITS AND ONE SN54S182/SN74S182 IN FULL LOOK-AHEAD CARRY MODE

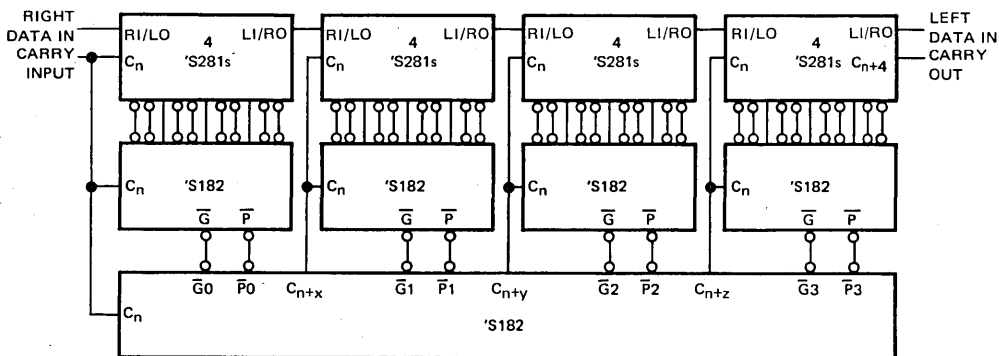

ENTER AND STORE TIME: 42 ns typical
EACH SUCCESSIVE ADDITION TO STORED DATA: 34 ns typical

FIGURE C—64-BIT BINARY ACCUMULATOR USING 16 SN54S281/SN74S281 CIRCUITS AND FIVE SN54S182/SN74S182 CIRCUITS FOR FULL CARRY LOOK-AHEAD

A inputs and F outputs of 'S281 are not shown.

3

TTL DEVICES

**TYPES SN54283, SN54LS283, SN54S283,
SN74283, SN74LS283, SN74S283
4-BIT BINARY FULL ADDERS WITH FAST CARRY**

logic diagram

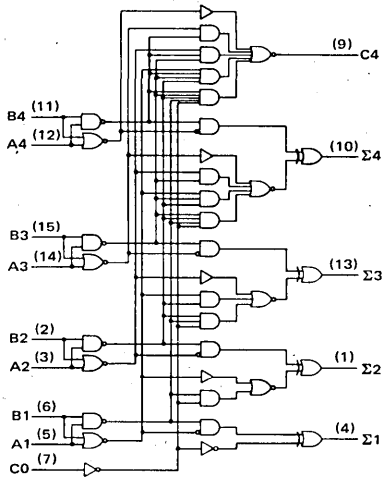

Pin numbers shown on logic notation are for D, J or N packages.

schematics of inputs and outputs

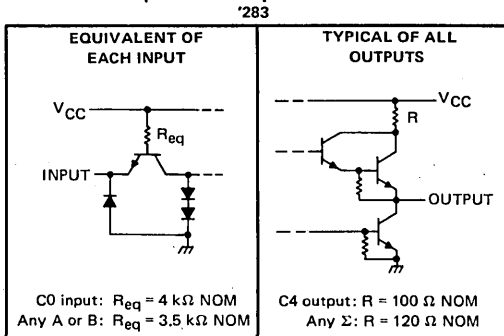

'LS283

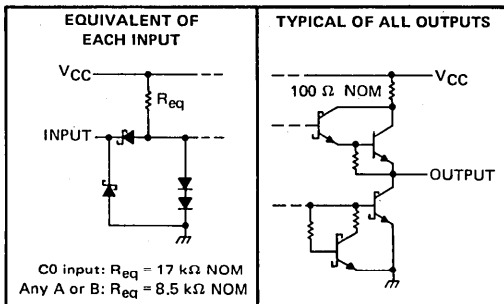

'S283

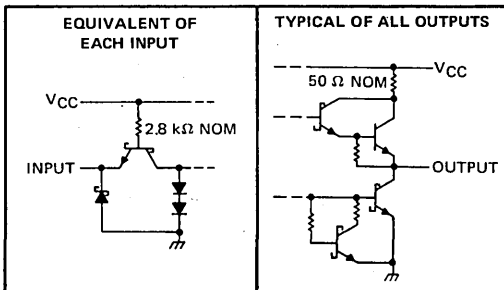

absolute maximum ratings over operating free-air temperature range (unless otherwise noted)

Supply voltage, V_{CC} (see Note 1)	7V
Input voltage: '283, 'S283	5.5V
'LS283	7V
Interemitter voltage (see Note 2)	5.5V
Operating free-air temperature range: SN54283, SN54LS283, SN54S283	-55°C to 125°C
SN74283, SN74LS283, SN74S283	0°C to 70°C
Storage temperature range	-65°C to 150°C

NOTES: 1. Voltage values, except interemitter voltage, are with respect to network ground terminal.

2. This is the voltage between two emitters of a multiple-emitter transistor. This rating applies for the '283 and 'S283 only between the following pairs: A1 and B1, A2 and B2, A3 and B3, A4 and B4.

TTL DEVICES

TYPES SN54283, SN74283 4-BIT BINARY FULL ADDERS WITH FAST CARRY

recommended operating conditions

		SN54283			SN74283			UNIT
		MIN	NOM	MAX	MIN	NOM	MAX	
Supply Voltage, V_{CC}		4.5	5	5.5	4.75	5	5.25	V
High-level output current, I_{OH}	Any output except C4	-800			-800			μ A
	Output C4	-400			-400			
Low-level output current, I_{OL}	Any output except C4	16			16			mA
	Output C4	8			8			
Operating free-air temperature, T_A		-55			125			$^{\circ}$ C

electrical characteristics over recommended operating free-air temperature range (unless otherwise noted)

PARAMETER		TEST CONDITIONS†	SN54283			SN74283			UNIT
			MIN	TYP‡	MAX	MIN	TYP‡	MAX	
V_{IH}	High-level input voltage		2			2			V
V_{IL}	Low-level input voltage		0.8			0.8			V
V_{IK}	Input clamp voltage	$V_{CC} = \text{MIN}, I_I = -12 \text{ mA}$	-1.5			-1.5			V
V_{OH}	High-level output voltage	$V_{CC} = \text{MIN}, V_{IH} = 2 \text{ V}, V_{IL} = 0.8 \text{ V}, I_{OH} = \text{MAX}$	2.4	3.6		2.4	3.6		V
V_{OL}	Low-level output voltage	$V_{CC} = \text{MIN}, V_{IH} = 2 \text{ V}, V_{IL} = 0.8 \text{ V}, I_{OL} = \text{MAX}$	0.2	0.4		0.2	0.4		V
I_I	Input current at maximum input voltage	$V_{CC} = \text{MAX}, V_I = 5.5 \text{ V}$	1			1			mA
I_{IH}	High-level input current	$V_{CC} = \text{MAX}, V_I = 2.4 \text{ V}$	40			40			μ A
I_{IL}	Low-level input current	$V_{CC} = \text{MAX}, V_I = 0.4 \text{ V}$	-1.6			-1.6			mA
I_{OS}	Short-circuit output current§	Any output except C4	-20	-55		-18	-55		mA
		Output C4	-20	-70		-18	-70		
I_{CC}	Supply current	$V_{CC} = \text{MAX},$ Outputs open	All B low, other inputs at 4.5 V		56	56		mA	
			All inputs at 4.5 V		66	99	66		110

† For conditions shown as MIN or MAX, use the appropriate value specified under recommended operating conditions.

‡ All typical values are at $V_{CC} = 5 \text{ V}, T_A = 25^{\circ}\text{C}$.

§ Only one output should be shorted at a time.

switching characteristics, $V_{CC} = 5 \text{ V}, T_A = 25^{\circ}\text{C}$

PARAMETER¶	FROM (INPUT)	TO (OUTPUT)	TEST CONDITIONS	MIN	TYP	MAX	UNIT
t_{PLH}	C0	Any Σ	$C_L = 15 \text{ pF}, R_L = 400 \Omega,$ See Note 3	14	21	ns	
t_{PHL}				12	21		
t_{PLH}	A_i or B_i	Σ_i		16	24	ns	
t_{PHL}				16	24		
t_{PLH}	C0	C4	$C_L = 15 \text{ pF}, R_L = 780 \Omega,$ See Note 3	9	14	ns	
t_{PHL}				11	16		
t_{PLH}	A_i or B_i	C4		9	14	ns	
t_{PHL}				11	16		

¶ t_{PLH} = Propagation delay time, low-to-high-level output

t_{PHL} = Propagation delay time, high-to-low-level output

NOTE 3: See General Information Section for load circuits and voltage waveforms.

TYPES SN54LS283, SN74LS283

4-BIT BINARY FULL ADDERS WITH FAST CARRY

recommended operating conditions

	SN54LS283			SN74LS283			UNIT
	MIN	NOM	MAX	MIN	NOM	MAX	
Supply voltage, V_{CC}	4.5	5	5.5	4.75	5	5.25	V
High-level output current, I_{OH}	-400			-400			μ A
Low-level output current, I_{OL}	4			8			mA
Operating free-air temperature, T_A	-55			125			$^{\circ}$ C

electrical characteristics over recommended operating free-air temperature range (unless otherwise noted)

PARAMETER		TEST CONDITIONS [†]	SN54LS283			SN74LS283			UNIT
			MIN	TYP [‡]	MAX	MIN	TYP [‡]	MAX	
V_{IH}	High-level input voltage		2			2			V
V_{IL}	Low-level input voltage		0.7			0.8			V
V_{IK}	Input clamp voltage	$V_{CC} = \text{MIN}, I_I = -18 \text{ mA}$	-1.5			-1.5			V
V_{OH}	High-level output voltage	$V_{CC} = \text{MIN}, V_{IH} = 2 \text{ V}, I_{OH} = -400 \mu\text{A}, V_{IL} = V_{IL \text{ max}}$	2.5	3.4		2.7	3.4		V
V_{OL}	Low-level output voltage	$V_{CC} = \text{MIN}, V_{IH} = 2 \text{ V}, V_{IL} = V_{IL \text{ max}}, I_{OL} = 4 \text{ mA}$ $I_{OL} = 8 \text{ mA}$	0.25	0.4		0.25	0.4		V
I_I	Input current at maximum input voltage	Any A or B CO $V_{CC} = \text{MAX}, V_I = 7 \text{ V}$	0.2			0.2			mA
			0.1			0.1			
I_{IH}	High-level input current	Any A or B CO $V_{CC} = \text{MAX}, V_I = 2.7 \text{ V}$	40			40			μ A
			20			20			
I_{IL}	Low-level input current	Any A or B CO $V_{CC} = \text{MAX}, V_I = 0.4 \text{ V}$	-0.8			-0.8			mA
			-0.4			-0.4			
I_{OS}	Short-circuit output current [§]	$V_{CC} = \text{MAX}$	-20	-100		-20	-100		mA
I_{CC}	Supply current	$V_{CC} = \text{MAX},$ Outputs open	All inputs grounded		22	39	22	39	mA
			All B low, other inputs at 4.5 V		19	34	19	34	
			All inputs at 4.5 V		19	34	19	34	

[†]For conditions shown as MIN or MAX, use the appropriate value specified under recommended operating conditions.

[‡]All typical values are at $V_{CC} = 5 \text{ V}, T_A = 25^{\circ}\text{C}$.

[§]Only one output should be shorted at a time and duration of the short-circuit should not exceed one second.

switching characteristics, $V_{CC} = 5 \text{ V}, T_A = 25^{\circ}\text{C}$

PARAMETER [†]	FROM (INPUT)	TO (OUTPUT)	TEST CONDITIONS		MIN	TYP	MAX	UNIT
t_{PLH}	CO	Any Σ	$C_L = 15 \text{ pF},$ See Note 3	$R_L = 2 \text{ k}\Omega,$	16	24		ns
t_{PHL}					15	24		
t_{PLH}	A_i or B_i	Σ_i			15	24		ns
t_{PHL}					15	24		
t_{PLH}	CO	C4			11	17		ns
t_{PHL}					11	22		
t_{PLH}	A_i or B_i	C4			11	17		ns
t_{PHL}					12	17		

[†] t_{PLH} = Propagation delay time, low-to-high-level output

t_{PHL} = Propagation delay time, high-to-low-level output

NOTE 3: See General Information Section for load circuits and voltage waveforms.

3 TTL DEVICES

TYPES SN54S283, SN74S283 4-BIT BINARY FULL ADDERS WITH FAST CARRY

recommended operating conditions

		SN54S283			SN74S283			UNIT	
		MIN	NOM	MAX	MIN	NOM	MAX		
Supply voltage, V_{CC}		4.5	5	5.5	4.75	5	5.25	V	
High-level output current, I_{OH}	Any output except C4	-1			-1			mA	
	Output C4	-500			-500			μ A	
Low-level output current, I_{OL}	Any output except C4	20			20			mA	
	Output C4	10			10			mA	
Operating free-air temperature, T_A		-55			125			0	$^{\circ}$ C

electrical characteristics over recommended operating free-air temperature range (unless otherwise noted)

PARAMETER		TEST CONDITIONS [†]		MIN	TYP [‡]	MAX	UNIT
V_{IH}	High-level input voltage			2			V
V_{IL}	Low-level input voltage					0.8	V
V_{IK}	Input clamp voltage	$V_{CC} = \text{MIN}$, $I_I = -18 \text{ mA}$				-1.2	V
V_{OH}	High-level output voltage	SN54S283	$V_{CC} = \text{MIN}$, $V_{IH} = 2 \text{ V}$	2.5	3.4		V
		SN74S283	$V_{IL} = 0.8 \text{ V}$, $I_{OH} = \text{MAX}$	2.7	3.4		V
V_{OL}	Low-level output voltage	$V_{CC} = \text{MIN}$, $V_{IH} = 2 \text{ V}$, $V_{IL} = 0.8 \text{ V}$, $I_{OL} = \text{MAX}$				0.5	V
I_I	Input current at maximum input voltage	$V_{CC} = \text{MAX}$, $V_I = 5.5 \text{ V}$				1	mA
I_{IH}	High-level input current	$V_{CC} = \text{MAX}$, $V_I = 2.7 \text{ V}$				50	μ A
I_{IL}	Low-level input current	$V_{CC} = \text{MAX}$, $V_I = 0.5 \text{ V}$				-2	mA
I_{OS}	Short-circuit output current [§]	Any output except C4	$V_{CC} = \text{MAX}$	-40		-100	mA
		Output C4		-20		-100	mA
I_{CC}	Supply current	$V_{CC} = \text{MAX}$, Outputs open	All B low, other inputs at 4.5 V	80			mA
				All inputs at 4.5 V	95	160	mA

[†] For conditions shown as MIN or MAX, use the appropriate value specified under recommended operating conditions for the applicable device type.

[‡] All typical values are at $V_{CC} = 5 \text{ V}$, $T_A = 25^{\circ}\text{C}$.

[§] Only one output should be shorted at a time, and duration of the short-circuit should not exceed one second.

switching characteristics, $V_{CC} = 5 \text{ V}$, $T_A = 25^{\circ}\text{C}$

PARAMETER [¶]	FROM (INPUT)	TO (OUTPUT)	TEST CONDITIONS	MIN	TYP	MAX	UNIT
t_{PLH}	C0	Any Σ	$C_L = 15 \text{ pF}$, $R_L = 280 \Omega$, See Note 3	11		18	ns
t_{PHL}				12		18	
t_{PLH}	A_i or B_i	Σ_i		12		18	ns
t_{PHL}				11.5		18	
t_{PLH}	C0	C4	$C_L = 15 \text{ pF}$, $R_L = 560 \Omega$, See Note 3	6		11	ns
t_{PHL}				7.5		11	
t_{PLH}	A_i or B_i	C4		7.5		12	ns
t_{PHL}				8.5		12	

[¶] t_{PLH} = Propagation delay time, low-to-high-level output

t_{PHL} = Propagation delay time, high-to-low-level output

NOTE 3: See General Information Section for load circuits and voltage waveforms.

TYPES SN54284, SN54285, SN74284, SN74285 4-BIT BY 4-BIT PARALLEL BINARY MULTIPLIERS

MAY 1972 — REVISED DECEMBER 1983

- Fast Multiplication of Two Binary Numbers
8-Bit Product in 40 ns Typical
- Expandable for N-Bit-by-n-Bit Applications:
16-Bit Product in 70 ns Typical
32-Bit Product in 103 ns Typical
- Fully Compatible with Most TTL Circuits
- Diode-Clamped Inputs Simplify System Design

description

These high-speed TTL circuits are designed to be used in high-performance parallel multiplication applications. When connected as shown in Figure A, these circuits perform the positive-logic multiplication of two 4-bit binary words. The eight-bit binary product is generated with typically only 40 nanoseconds delay.

This basic four-by-four multiplier can be utilized as a fundamental building block for implementing larger multipliers. For example, the four-by-four building blocks can be connected as shown in Figure B to generate submultiple partial products. These results can then be summed in a Wallace tree, and, as illustrated, will produce a 16-bit product for the two eight-bit words typically in 70 nanoseconds. SN54H183/SN74H183 carry-save adders and SN54S181/SN74S181 arithmetic logic units with the SN54S182/SN74S182 look-ahead generator are used to achieve this high performance. The scheme is expandable for implementing $N \times M$ bit multipliers.

The SN54284 and SN54285 are characterized for operation over the full military temperature range of -55°C to 125°C ; the SN74284 and SN74285 are characterized for operation from 0°C to 70°C .

SN54284 ... J OR W PACKAGE
SN74284 ... J OR N PACKAGE
(TOP VIEW)

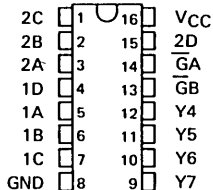

SN54285 ... J OR W PACKAGE
SN74285 ... J OR N PACKAGE
(TOP VIEW)

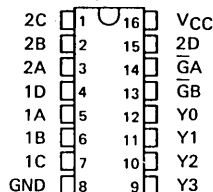

logic symbols

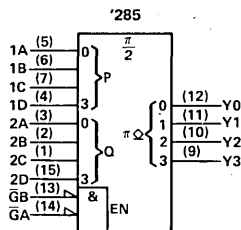
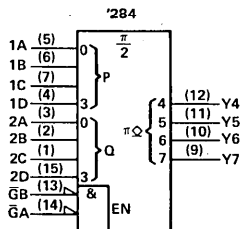

Pin numbers shown are for J and N packages.

PRODUCTION DATA

This document contains information current as of publication date. Products conform to specifications per the terms of Texas Instruments standard warranty. Production processing does not necessarily include testing of all parameters.

TEXAS
INSTRUMENTS

POST OFFICE BOX 225012 • DALLAS, TEXAS 75265

TYPES SN54284, SN54285, SN74284, SN74285 4-BIT BY 4-BIT PARALLEL BINARY MULTIPLIERS

schematics

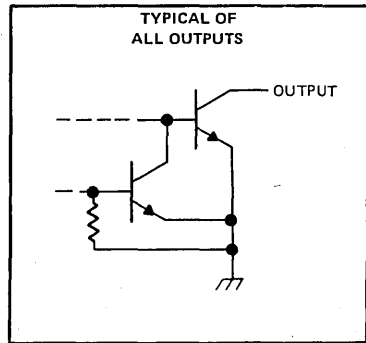
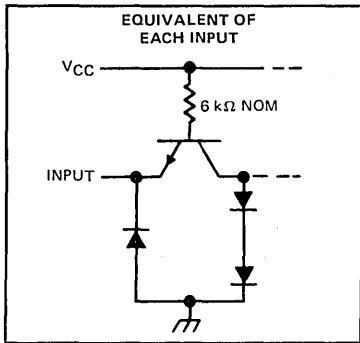

BINARY INPUTS

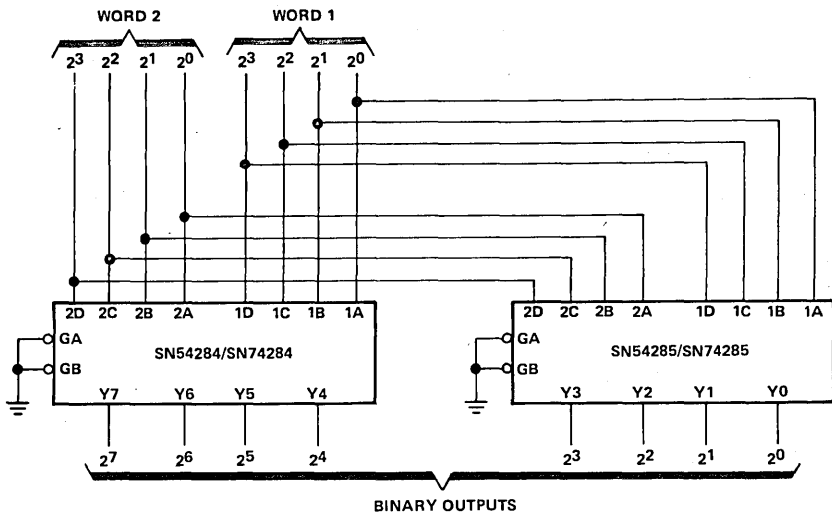

FIGURE A-4 X 4 MULTIPLIER

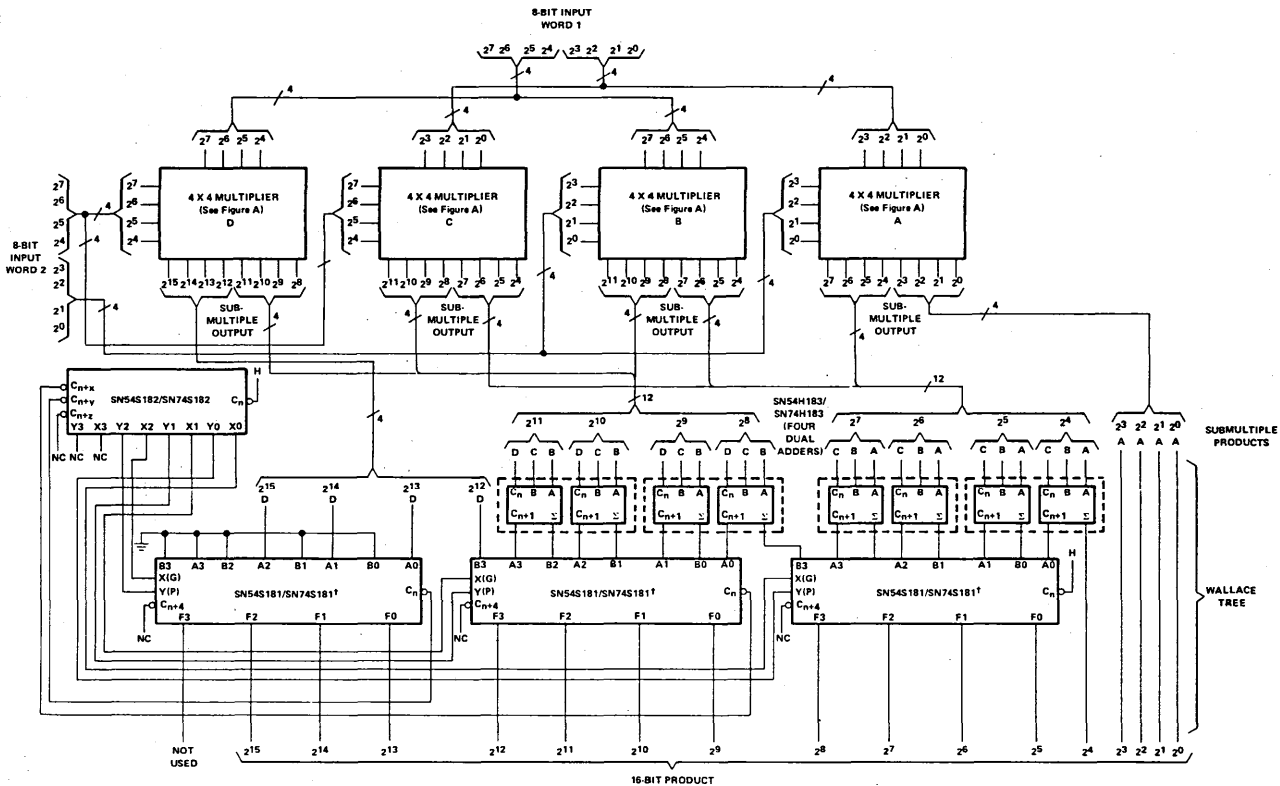

FIGURE B-8 X 8 MULTIPLIER

†Other terminals of the three SN54S181/SN74S181 ALU's are connected as follows: S3 = H, S2 = L, S1 = L, S0 = H, M = L. Output A = B is not used for this application.

TYPES SN54284, SN54285, SN74284, SN74285 4-BIT BY 4-BIT PARALLEL BINARY MULTIPLIERS

absolute maximum ratings over operating free-air temperature range (unless otherwise noted)

Supply voltage, V_{CC} (see Note 1)	7 V
Input voltage	5.5 V
Operating free-air temperature range: SN54 [†] Circuits	-55°C to 125°C
SN74 [†] Circuits	0°C to 70°C
Storage temperature range	-65°C to 150°C

NOTE 1: Voltage values are with respect to network ground terminal.

recommended operating conditions

	SN54284			SN74284			UNIT
	SN54285			SN74285			
	MIN	NOM	MAX	MIN	NOM	MAX	
Supply voltage, V_{CC}	4.5	5	5.5	4.75	5	5.25	V
High-level output voltage, V_{OH}	5.5			5.5			V
Low-level output current, I_{OL}	16			16			mA
Operating free-air temperature, T_A	-55			0			70 °C

electrical characteristics over recommended operating free-air temperature range (unless otherwise noted)

PARAMETER	TEST CONDITIONS [†]	MIN	TYP [‡]	MAX	UNIT
V_{IH} High-level input voltage		2			V
V_{IL} Low-level input voltage				0.8	V
V_I Input clamp voltage	$V_{CC} = \text{MIN}$, $I_I = -12 \text{ mA}$			-1.5	V
I_{OH} High-level output current	$V_{CC} = \text{MIN}$, $V_{IH} = 2 \text{ V}$, $V_{IL} = 0.8 \text{ V}$, $V_{OH} = 5.5 \text{ V}$			40	μA
V_{OL} Low-level output voltage	$V_{CC} = \text{MIN}$, $V_{IH} = 2 \text{ V}$, $V_{IL} = 0.8 \text{ V}$	$I_{OL} = 12 \text{ mA}$		0.4	V
		$I_{OL} = 16 \text{ mA}$		0.45	
I_I Input current at maximum input voltage	$V_{CC} = \text{MAX}$, $V_I = 5.5 \text{ V}$			1	mA
I_{IH} High-level input current	$V_{CC} = \text{MAX}$, $V_I = 2.4 \text{ V}$			40	μA
I_{IL} Low-level input current	$V_{CC} = \text{MAX}$, $V_I = 0.4 \text{ V}$			-1	mA
I_{CC} Supply current	$V_{CC} = \text{MAX}$, $T_A = 125^\circ\text{C}$, See Note 2	SN54284, SN54285 N package only		99	mA
	$V_{CC} = \text{MAX}$, See Note 2	SN54284, SN54285 SN74284, SN74285		92 110 92 130	

[†]For conditions shown as MIN or MAX, use the appropriate value specified under recommended operating conditions for the applicable device type.

[‡]All typical values are at $V_{CC} = 5 \text{ V}$, $T_A = 25^\circ\text{C}$.

NOTE 2: With outputs open and both enable inputs grounded, I_{CC} is measured first by selecting an output product which contains three or more high-level bits, then by selecting an output product which contains four low-level bits.

switching characteristics, $V_{CC} = 5 \text{ V}$, $T_A = 25^\circ\text{C}$

PARAMETER	TEST CONDITIONS	MIN	TYP	MAX	UNIT	
t_{PLH} Propagation delay time, low-to-high-level output from enable	$C_L = 30 \text{ pF}$ to GND, $R_{L1} = 300 \Omega$ to V_{CC} , $R_{L2} = 600 \Omega$ to GND, See Note 3		20	30	ns	
t_{PHL} Propagation delay time, high-to-low-level output from enable			20	30		
t_{PLH} Propagation delay time, low-to-high-level output from word inputs				40	60	ns
t_{PHL} Propagation delay time, high-to-low-level output from word inputs				40	60	

NOTE 3: See General Information Section for load circuits and voltage waveforms.

TYPES SN54290, SN54293, SN54LS290, SN54LS293, SN74290, SN74293, SN74LS290, SN74LS293 DECADE AND 4-BIT BINARY COUNTERS

MARCH 1974—REVISED DECEMBER 1983

'290, 'LS290 . . . DECADE COUNTERS
'293, 'LS293 . . . 4-BIT BINARY COUNTERS

SN54290, SN54LS290, SN54293,
SN54LS293 . . . J OR W PACKAGE
SN74290, SN74293 . . . J OR N PACKAGE
SN74LS290, SN74LS293 . . . D, J OR N PACKAGE
(TOP VIEW)

- GND and V_{CC} on Corner Pins
(Pins 7 and 14 Respectively)

description

The SN54290/SN74290, SN54LS290/SN74LS290, SN54293/SN74293, and SN54LS293/SN74LS293 counters are electrically and functionally identical to the SN5490A/SN7490A, SN54LS90/SN74LS90, SN5493A/SN7493A, and SN54LS93/SN74LS93, respectively. Only the arrangement of the terminals has been changed for the '290, 'LS290, '293, and 'LS293.

Each of these monolithic counters contains four master-slave flip-flops and additional gating to provide a divide-by-two counter and a three-stage binary counter for which the count cycle length is divide-by-five for the '290 and 'LS290 and divide-by-eight for the '293 and 'LS293.

All of these counters have a gated zero reset and the '290 and 'LS290 also have gated set-to-nine inputs for use in BCD nine's complement applications.

To use the maximum count length (decade or four-bit binary) of these counters, the B input is connected to the Q_D output. The input count pulses are applied to input A and the outputs are as described in the appropriate function table. A symmetrical divide-by-ten count can be obtained from the '290 and 'LS290 counters by connecting the Q_D output to the A input and applying the input count to the B input which gives a divide-by-ten square wave at output Q_A.

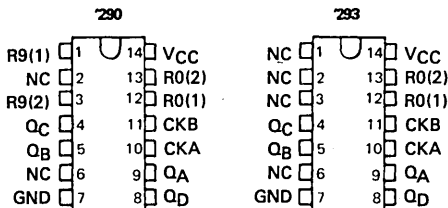

SN54LS290, SN54LS293 . . . FK PACKAGE
SN74LS290, SN74LS293 . . . FN PACKAGE
(TOP VIEW)

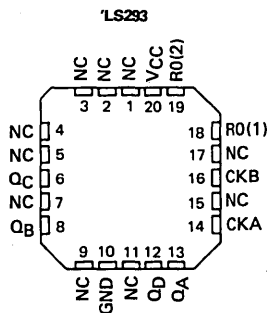
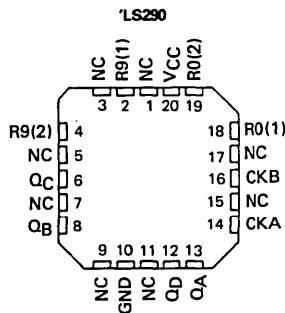

NC - No internal connection

PRODUCTION DATA
This document contains information current as of publication date. Products conform to specifications per the terms of Texas Instruments standard warranty. Production processing does not necessarily include testing of all parameters.

**TEXAS
INSTRUMENTS**

POST OFFICE BOX 225012 • DALLAS, TEXAS 75265

TTL DEVICES

3

TYPES SN54290, SN54293, SN54LS290, SN54LS293, SN74290, SN74293, SN74LS290, SN74LS293 DECADE AND 4-BIT BINARY COUNTERS

'290, 'LS290
BCD COUNT SEQUENCE
(See Note A)

COUNT	OUTPUT			
	Q _D	Q _C	Q _B	Q _A
0	L	L	L	L
1	L	L	L	H
2	L	L	H	L
3	L	L	H	H
4	L	H	L	L
5	L	H	L	H
6	L	H	H	L
7	L	H	H	H
8	H	L	L	L
9	H	L	L	H

'290, 'LS290
BI-QUINARY (5-2)
(See Note B)

COUNT	OUTPUT			
	Q _A	Q _D	Q _C	Q _B
0	L	L	L	L
1	L	L	L	H
2	L	L	H	L
3	L	L	H	H
4	L	H	L	L
5	H	L	L	L
6	H	L	L	H
7	H	L	H	L
8	H	L	H	H
9	H	H	L	L

'290, 'LS290
RESET/COUNT FUNCTION TABLE

RESET INPUTS				OUTPUT			
R ₀ (1)	R ₀ (2)	R ₉ (1)	R ₉ (2)	Q _D	Q _C	Q _B	Q _A
H	H	L	X	L	L	L	L
H	H	X	L	L	L	L	L
X	X	H	H	H	L	L	H
X	L	X	L	COUNT			
L	X	L	X	COUNT			
L	X	X	L	COUNT			
X	L	L	X	COUNT			

'293, 'LS293
COUNT SEQUENCE
(See Note C)

COUNT	OUTPUT			
	Q _D	Q _C	Q _B	Q _A
0	L	L	L	L
1	L	L	L	H
2	L	L	H	L
3	L	L	H	H
4	L	H	L	L
5	L	H	L	H
6	L	H	H	L
7	L	H	H	H
8	H	L	L	L
9	H	L	L	H
10	H	L	H	L
11	H	L	H	H
12	H	H	L	L
13	H	H	L	H
14	H	H	H	L
15	H	H	H	H

- NOTES: A. Output Q_A is connected to input B for BCD count.
 B. Output Q_D is connected to input A for bi-quinary count.
 C. Output Q_A is connected to input B.
 D. H = high level, L = low level, X = irrelevant

'293, 'LS293
RESET/COUNT FUNCTION TABLE

RESET INPUTS		OUTPUT			
R ₀ (1)	R ₀ (2)	Q _D	Q _C	Q _B	Q _A
H	H	L	L	L	L
L	X	COUNT			
X	L	COUNT			

logic diagrams

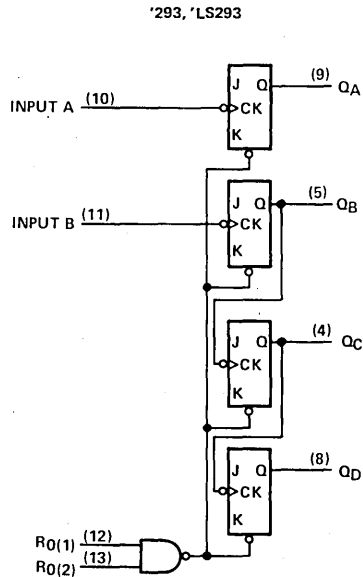
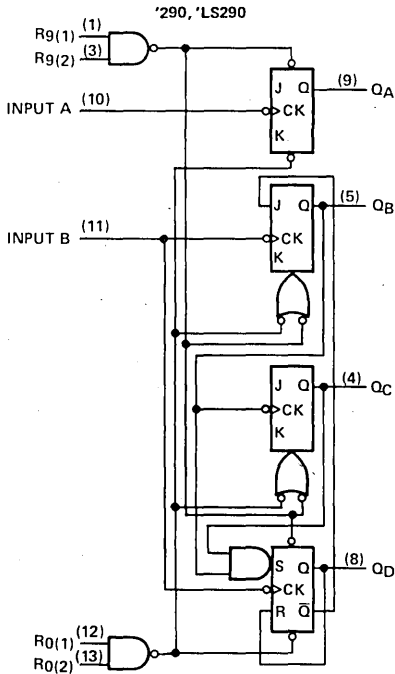

Pin numbers shown on logic notation are for D, J or N packages.

The J and K inputs shown without connection are for reference only and are functionally at a high level.

3

TTL DEVICES



POST OFFICE BOX 225012 • DALLAS, TEXAS 75265

schematics of inputs and outputs

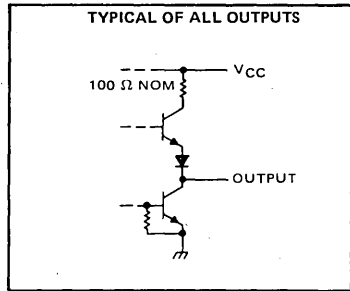
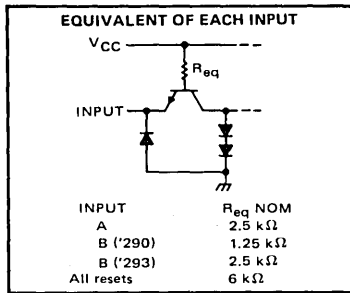

absolute maximum ratings over operating free-air temperature range (unless otherwise noted)

Supply voltage, V_{CC} (see Note 1)	7 V
Input voltage	5.5 V
Intermitter voltage (see Note 2)	5.5 V
Operating free-air temperature range: SN54' Circuits	-55°C to 125°C
SN74' Circuits	0°C to 70°C
Storage temperature range	-65°C to 150°C

NOTES: 1. Voltage values, except intermitter voltage, are with respect to network ground terminal.

2. This is the voltage between two emitters of a multiple-emitter transistor. For these circuits, this rating applies between the two R_0 inputs, and for the '290 circuit, it also applies between the two R_9 inputs.

recommended operating conditions

		SN54'			SN74'			UNIT
		MIN	NOM	MAX	MIN	NOM	MAX	
Supply voltage, V_{CC}		4.5	5	5.5	4.75	5	5.25	V
High-level output current, I_{OH}				-800			-800	μ A
Low-level output current, I_{OL}				16			16	mA
Count frequency, f_{count}	A input	0		32	0		32	MHz
	B input	0		16	0		16	
Pulse width, t_w	A input	15			15			ns
	B input	30			30			
	Reset inputs	15			15			
Reset inactive-state setup time, t_{su}		25			25			ns
Operating free-air temperature, T_A		-55		125	0		70	°C

TTL DEVICES

TYPES SN54290, SN54293, SN74290, SN74293
DECADE AND 4-BIT BINARY COUNTERS

electrical characteristics over recommended operating free-air temperature range (unless otherwise noted)

PARAMETER	TEST CONDITIONS†	'290			'293			UNIT	
		MIN	TYP‡	MAX	MIN	TYP‡	MAX		
V _{IH}	High-level input voltage	2			2			V	
V _{IL}	Low-level input voltage				0.8			V	
V _{IK}	Input clamp voltage	V _{CC} = MIN, I _I = -12 mA			-1.5			V	
V _{OH}	High-level output voltage	V _{CC} = MIN, V _{IH} = 2 V, V _{IL} = 0.8 V, I _{OH} = -800 µA			2.4	3.4	2.4	3.4	V
V _{OL}	Low-level output voltage	V _{CC} = MIN, V _{IH} = 2 V, V _{IL} = 0.8 V, I _{OL} = 16 mA¶			0.2	0.4	0.2	0.4	V
I _I	Input current at maximum input voltage	V _{CC} = MAX, V _I = 5.5 V			1			mA	
I _{IH}	High-level input current	Any reset					40		µA
		A input		V _{CC} = MAX, V _I = 2.4 V			80		
		B input					120		
I _{IL}	Low-level input current	Any reset					-1.6		mA
		A input		V _{CC} = MAX, V _I = 0.4 V			-3.2		
		B input					-4.8		
I _{OS}	Short-circuit output current§	V _{CC} = MAX		SN54*	-20	-57	-20	-57	mA
				SN74*	-18	-57	-18	-57	
I _{CC}	Supply current	V _{CC} = MAX, See Note 3			29	42	26	39	mA

† For conditions shown as MIN or MAX, use the appropriate value specified under recommended operating conditions.

‡ All typical values are at V_{CC} = 5 V, T_A = 25°C.

§ Not more than one output should be shorted at a time.

¶ Q_A outputs are tested at I_{OL} = 16 mA plus the limit value of I_{IL} for the B input. This permits driving the B input while maintaining full fan-out capability.

NOTE 3: I_{CC} is measured with all outputs open, both R₀ inputs grounded following momentary connection to 4.5 V, and all other inputs grounded.

switching characteristics, V_{CC} = 5 V, T_A = 25°C

PARAMETER [◇]	FROM (INPUT)	TO (OUTPUT)	TEST CONDITIONS	'290			'293			UNIT
				MIN	TYP	MAX	MIN	TYP	MAX	
f _{max}	A	Q _A	C _L = 15 pF, R _L = 400 Ω, See Note 4	32	42		32	42	MHz	
	B	Q _B		16			16			
tp _{PLH}	A	Q _A		10	16		10	16	ns	
tp _{PHL}				12	18		12	18		
tp _{PLH}	A	Q _D		32	48		46	70	ns	
tp _{PHL}				34	50		46	70		
tp _{PLH}	B	Q _B		10	16		10	16	ns	
tp _{PHL}				14	21		14	21		
tp _{PLH}	B	Q _C		21	32		21	32	ns	
tp _{PHL}				23	35		23	35		
tp _{PLH}	B	Q _D		21	32		34	51	ns	
tp _{PHL}				23	35		34	51		
tp _{PHL}	Set-to-0	Any		26	40		26	40	ns	
tp _{PLH}	Set-to-9	Q _A , Q _D		20	30				ns	
tp _{PHL}		Q _B , Q _C		26	40					

◇ f_{max} = maximum count frequency

tp_{PLH} = propagation delay time, low-to-high-level output

tp_{PHL} = propagation delay time, high-to-low-level output

NOTE 4: See General Information Section for load circuits and voltage waveforms.

3 TTL DEVICES

TYPES SN54LS290, SN54LS293, SN74LS290, SN74LS293 DECADE AND 4-BIT BINARY COUNTERS

REVISED OCTOBER 1976

schematics of inputs and outputs

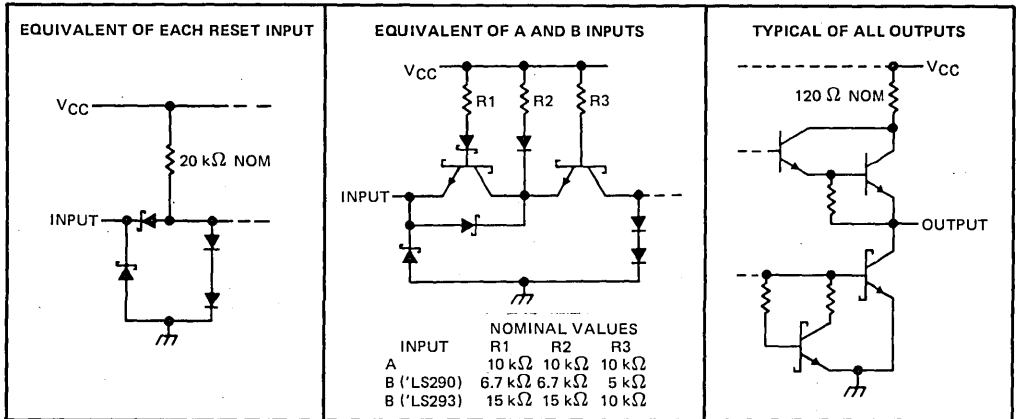

absolute maximum ratings over operating free-air temperature range (unless otherwise noted)

Supply voltage, V_{CC} (see Note 5)	7 V
Input voltage: R inputs	7 V
A and B inputs	5.5 V
Operating free-air temperature range: SN54LS290, SN54LS293	-55°C to 125°C
SN74LS290, SN74LS293	0°C to 70°C
Storage temperature range	-65°C to 150°C

NOTE 5: Voltage values are with respect to network ground terminal.

recommended operating conditions

	SN54LS'			SN74LS'			UNIT
	MIN	NOM	MAX	MIN	NOM	MAX	
Supply voltage, V_{CC}	4.5	5	5.5	4.75	5	5.25	V
High-level output current, I_{OH}			-400			-400	μA
Low-level output current, I_{OL}			4			8	mA
Count frequency, f_{count}	A input	0	32	0	32		MHz
	B input	0	16	0	16		
Pulse width, t_w	A input	15		15			ns
	B input	30		30			
	Reset inputs	30		30			
Reset inactive-state setup time, t_{SU}		25		25			ns
Operating free-air temperature, T_A		-55	125		0	70	°C

TYPES SN54LS290, SN54LS293, SN74LS290, SN74LS293 DECADE AND 4-BIT BINARY COUNTERS

electrical characteristics over recommended operating free-air temperature range (unless otherwise noted)

PARAMETER	TEST CONDITIONS†	SN54LS*		SN74LS*		UNIT			
		MIN	TYP‡	MAX	MIN		TYP‡	MAX	
V _{IH} High-level input voltage		2			2	V			
V _{IL} Low-level input voltage				0.7		0.8	V		
V _{IK} Input clamp voltage				-1.5		-1.5	V		
V _{OH} High-level output voltage	V _{CC} = MIN, I _I = -18 mA V _{IH} = 2 V, V _{IL} = V _{IL} max, I _{OH} = -400 µA	2.5	3.4		2.7	3.4	V		
V _{OL} Low-level output voltage	V _{CC} = MIN, V _{IH} = 2 V, V _{IL} = V _{IL} max			I _{OL} = 4 mA¶ I _{OL} = 8 mA¶	0.25	0.4	0.25	0.4	V
I _I Input current at maximum input voltage	Any reset	V _{CC} = MAX, V _I = 7 V			0.1		0.1	mA	
	A input				0.2		0.2		
	B of 'LS290	V _{CC} = MAX, V _I = 5.5 V			0.4		0.4		
	B of 'LS293				0.2		0.2		
I _{IH} High-level input current	Any reset	V _{CC} = MAX, V _I = 2.7 V			20		20	µA	
	A input				40		40		
	B of 'LS290				80		80		
	B of 'LS293				40		40		
I _{IL} Low-level input current	Any reset	V _{CC} = MAX, V _I = 0.4 V			-0.4		-0.4	mA	
	A input				-2.4		-2.4		
	B of 'LS290				-3.2		-3.2		
	B of 'LS293				-1.6		-1.6		
I _{OS} Short-circuit output current§	V _{CC} = MAX	-20	-100	-20	-100			mA	
I _{CC} Supply current	V _{CC} = MAX, See Note 3	'LS290		9	15	9	15	mA	
		'LS293		9	15	9	15		

† For conditions shown as MIN or MAX, use the appropriate value specified under recommended operating conditions.

‡ All typical values are at V_{CC} = 5 V, T_A = 25°C.

§ Not more than one output should be shorted at a time, and duration of the short-circuit should not exceed one second.

¶ Q_A outputs are tested at specified I_{OL} plus the limit value of I_{IL} for the B input. This permits driving the B input while maintaining full fan-out capability.

NOTE 3: I_{CC} is measured with all outputs open, both R₀ inputs grounded following momentary connection to 4.5 V, and all other inputs grounded.

switching characteristics, V_{CC} = 5 V, T_A = 25°C

PARAMETER [◇]	FROM (INPUT)	TO (OUTPUT)	TEST CONDITIONS	'LS290			'LS293			UNIT
				MIN	TYP	MAX	MIN	TYP	MAX	
f _{max}	A	Q _A	C _L = . pF, R _L = 2 kΩ, See Note 4	32	42		32	42		MHz
	B	Q _B		16			16			
t _{PLH}	A	Q _A			10	16		10	16	ns
t _{PHL}					12	18		12	18	
t _{PLH}	A	Q _D			32	48		46	70	ns
t _{PHL}					34	50		46	70	
t _{PLH}	B	Q _B			10	16		10	16	ns
t _{PHL}					14	21		14	21	
t _{PLH}	B	Q _C			21	32		21	32	ns
t _{PHL}					23	35		23	35	
t _{PLH}	B	Q _D			21	32		34	51	ns
t _{PHL}					23	35		34	51	
t _{PHL}	Set-to-0	Any			26	40		26	40	ns
t _{PLH}	Set-to-9	Q _A , Q _D			20	30				ns
t _{PHL}		Q _B , Q _C		26	40					

◇ f_{max} = maximum count frequency

t_{PLH} = Propagation delay time, low-to-high-level output

t_{PHL} = Propagation delay time, high-to-low-level output

NOTE 4: See General Information Section for load circuits and voltage waveforms.



POST OFFICE BOX 225012 • DALLAS, TEXAS 75265

TYPES SN54LS292, SN54LS294, SN74LS292, SN74LS294 PROGRAMMABLE FREQUENCY DIVIDERS/DIGITAL TIMERS

D2628, JANUARY 1981—REVISED DECEMBER 1983

- Count Divider Chain
- Digitally Programmable from 2^2 to 2^n
($n = 31$ for 'LS292, $n = 15$ for 'LS294)
- Useable Frequency Range from DC to 30 MHz
- Easily Expandable
- Applications
 - Frequency Division
 - Digital Timing

description

These programmable frequency dividers/digital timers contain 31 flip-flops plus 30 gates ('LS292) or 15 flip-flops plus 29 gates ('LS294) on a single chip. The count modulo is under digital control of the inputs provided.

Both types feature an active-low clear input to initialize the state of all flip-flops. To facilitate incoming inspection, test points are provided (TP1, TP2, and TP3 on the 'LS292 and TP on the 'LS294). These test points are not intended to drive system loads. Both types feature two clock inputs; either one may be used for clock gating. (See the function table below.)

A brief look at the digital timing capabilities of the 'LS292 will show that with a 1-MHz input frequency, programming for 2^{10} will give a period of 1.024 ms, and 2^{20} will give a period of 1.05 sec, 2^{26} will give a period of 1.12 min, and 2^{31} will give a period of 35.79 min.

These devices are easily cascadable giving limitless possibilities to timing delays that can be achieved.

FUNCTION TABLE

CLEAR	CLK 1	CLK 2	Q OUTPUT MODE
L	X	X	Cleared to L
H	↑	L	Count
H	L	↑	Count
H	H	X	Inhibit
H	X	H	Inhibit

SN54LS292 ... J OR W PACKAGE
SN74LS292 ... J OR N PACKAGE

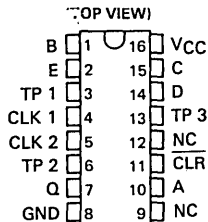

SN54LS292 ... FK PACKAGE
SN74LS292 ... FN PACKAGE

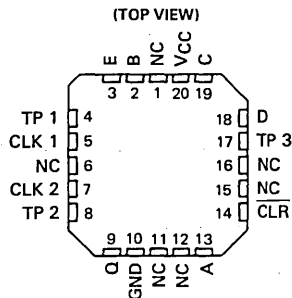

SN54LS294 ... J OR W PACKAGE
SN74LS294 ... J OR N PACKAGE

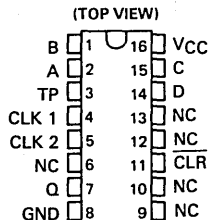

SN54LS294 ... FK PACKAGE
SN74LS294 ... FN PACKAGE

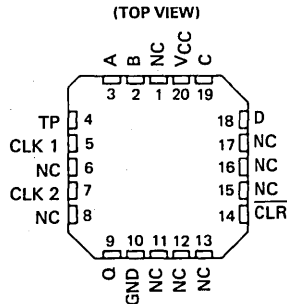

NC — No internal connection.

PRODUCTION DATA

This document contains information current as of publication date. Products conform to specifications per the terms of Texas Instruments standard warranty. Production processing does not necessarily include testing of all parameters.

TEXAS INSTRUMENTS

POST OFFICE BOX 225012 • DALLAS, TEXAS 75265

3

TTL DEVICES

TYPES SN54LS292, SN54LS294, SN74LS292, SN74LS294 PROGRAMMABLE FREQUENCY DIVIDERS/DIGITAL TIMERS

schematics of inputs and outputs

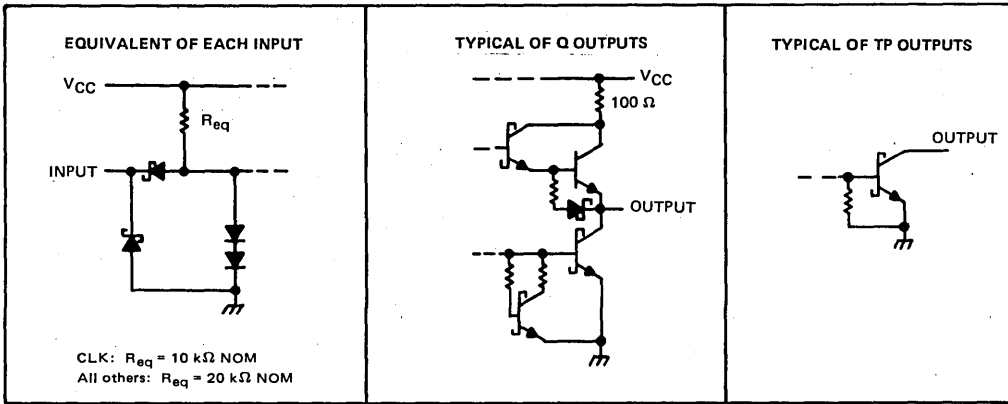

operation

The functional block diagram shows that the count modulo is controlled by an X/Y decoder connected to the mode control inputs of several flip-flops. These flip-flops with mode controls each have a "D" input connected to the parallel clock line and a "T" input driven by the preceding stage. The parallel clock frequency is always the input frequency divided by four.

The X/Y decoder output selected by the programming inputs goes low. While a mode control is low, the "D" input of that flip-flop is enabled, and the signal from the parallel clock line ($f_{in} \div 4$) is passed to the "T" input of the following stage. All the other mode controls are high enabling the "T" inputs and causing each flip-flop in turn to divide by two.

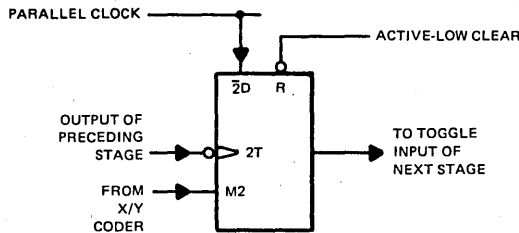

logic symbols

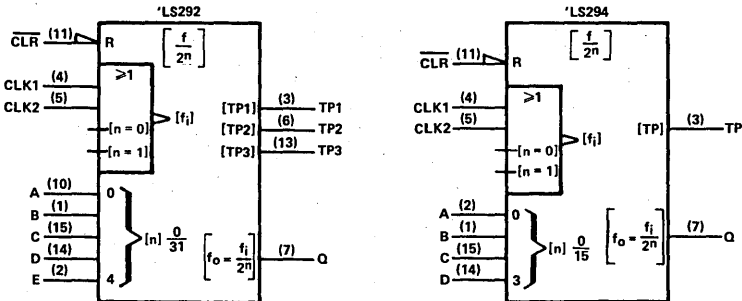

Pin numbers shown on logic notation are for J or N packages.

TYPES SN54LS292, SN54LS294, SN74LS292, SN74LS294 PROGRAMMABLE FREQUENCY DIVIDERS/DIGITAL TIMERS

logic diagram (positive logic)

'LS292

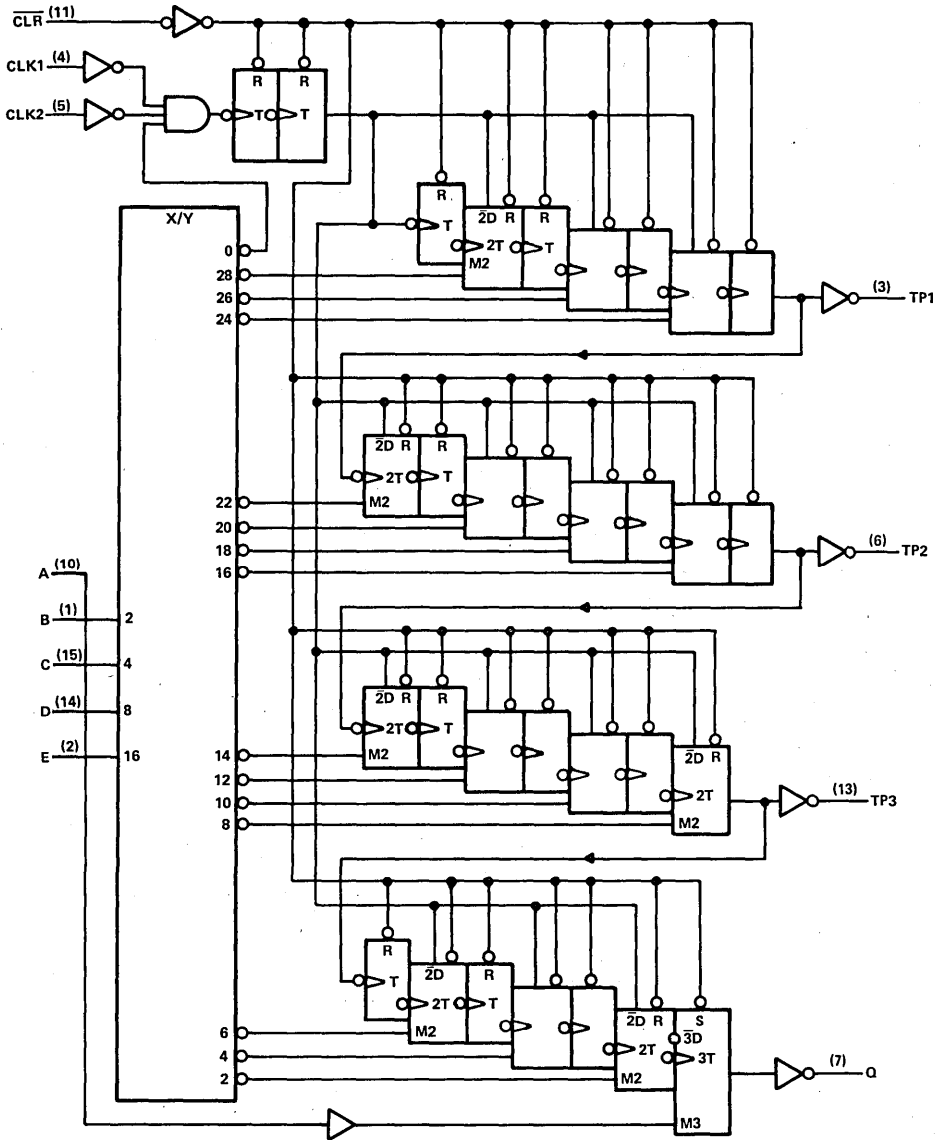

Pin numbers shown on logic notation are for J or N packages.

3
TTL DEVICES

TYPES SN54LS292, SN54LS294, SN74LS292, SN74LS294
PROGRAMMABLE FREQUENCY DIVIDERS/DIGITAL TIMERS

logic diagram (positive logic)

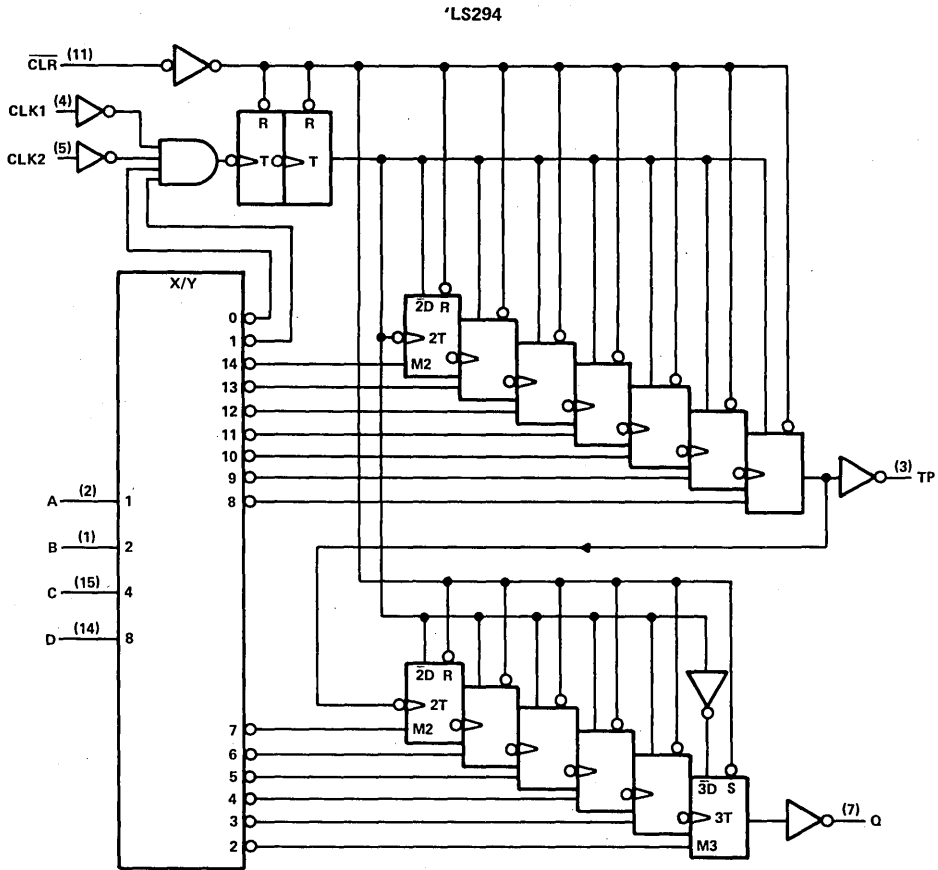

Pin numbers shown on logic notation are for J or N packages.

absolute maximum ratings over operating free-air temperature range (unless otherwise noted)

Supply voltage, V_{CC} (see Note 1)	7 V
Input voltage	7 V
Operating free-air temperature range: SN54LS292, SN54LS294	-55°C to 125°C
SN74LS292, SN74LS294	0°C to 70°C
Storage temperature range	-65°C to 150°C

NOTE 1: Voltage values are with respect to network ground terminal.

3 TTL DEVICES

TYPES SN54LS292, SN54LS294, SN74LS292, SN74LS294 PROGRAMMABLE FREQUENCY DIVIDERS/DIGITAL TIMERS

recommended operating conditions

		SN54LS'			SN74LS'			UNIT	
		MIN	NOM	MAX	MIN	NOM	MAX		
V _{CC}	Supply voltage	4.5	5	5.5	4.75	5	5.25	V	
V _{IH}	High-level input voltage	2			2			V	
V _{IL}	Low-level input voltage				0.7			V	
I _{OH}	High-level output current (Q only)				-1.2			mA	
I _{OL}	Low-level output current (Q only)				12			mA	
f _{clock}	Clock frequency	0			30			MHz	
t _w	Duration of clock input pulse	16			16			ns	
t _w	Duration of clear pulse	'LS292			55			ns	
		'LS294			35				
t _{su}	Clear inactive-state setup time	15			15			ns	
T _A	Operating free-air temperature	-55		125		0		70	°C

electrical characteristics over recommended operating free-air temperature range (unless otherwise noted)

PARAMETER		TEST CONDITIONS†	SN54LS'			SN74LS'			UNIT	
			MIN	TYP	MAX	MIN	TYP	MAX		
V _{IH}		V _{CC} = MIN, I _I = -18 mA				-1.5			V	
V _{OH}	Q	V _{CC} = MIN, V _{IH} = 2 V, V _{IL} = MAX, I _{OH} = -1.2 mA,	2.4	3.4		2.4	3.4		V	
V _{OL}	Q	V _{CC} = MIN, V _{IH} = 2 V, V _{IL} = MAX, I _{OL} = 12 mA	0.25			0.25			0.4	
	TP‡					0.35			0.5	
		I _{OL} = 0.5 mA				0.25			0.4	
I _I		V _{CC} = MAX, V _I = 7 V				0.1			mA	
I _{IH}		V _{CC} = MAX, V _I = 2.7 V				20			μA	
I _{IL}	CLK1, CLK2	V _{CC} = MAX, V _I = 0.4 V				-0.8			mA	
	All others					-0.4				
I _{OS} §	Q	V _{CC} = MAX	-30	-130		-30	-130		mA	
I _{CC}	'LS292	V _{CC} = MAX, All inputs grounded, All outputs open	40		75		40		75	
	'LS294		30		50		30		50	

† For conditions shown as MIN or MAX, use the appropriate value specified under recommended operating conditions.

‡ All typical values are at V_{CC} = 5 V, T_A = 25°C.

§ The duration of the short-circuit should not exceed one second.

◆ The TP output or outputs are not intended to drive external loads but are solely provided for test points.



TTL DEVICES

TYPES SN54LS292, SN54LS294, SN74LS292, SN74LS294

PROGRAMMABLE FREQUENCY DIVIDERS/DIGITAL TIMERS

switching characteristics, $V_{CC} = 5\text{ V}$, $T_A = 25^\circ\text{C}$, $R_L = 667\ \Omega$, $C_L = 45\text{ pF}$, (see note 2)

PARAMETER	FROM (INPUT)	TO (OUTPUT)	TEST CONDITIONS	'LS292			'LS294			UNIT
				MIN	TYP	MAX	MIN	TYP	MAX	
f_{max}	CLK1 or 2			30	50		30	50	MHz	
t_{PLH}		Q	Modulo set at 22, A thru E = LLLHL ('LS292) A thru D = LLHL ('LS294)		55	90		55	90	ns
t_{PHL}		Q		80	120		80	120	ns	
t_{PHL}	$\overline{\text{CLR}}$	Q		85	130		35	65	ns	

f_{MAX} = maximum clock frequency

t_{PLH} = Propagation delay time, low-to-high-level output

t_{PHL} = Propagation delay time, high-to-low-level output

NOTE 2: See General Information Section for load circuits and voltage waveforms.

To be used on TP outputs only.

'LS292 FUNCTION TABLE

PROGRAMMING INPUTS					FREQUENCY DIVISION							
E	D	C	B	A	Q		TP1		TP2		TP3	
					BINARY	DECIMAL	BINARY	DECIMAL	BINARY	DECIMAL	BINARY	DECIMAL
L	L	L	L	L	Inhibit	Inhibit	Inhibit	Inhibit	Inhibit	Inhibit	Inhibit	Inhibit
L	L	L	L	H	Inhibit	Inhibit	Inhibit	Inhibit	Inhibit	Inhibit	Inhibit	Inhibit
L	L	L	H	L	2^2	4	2^9	512	2^{17}	131,072	2^{24}	16,777,216
L	L	L	H	H	2^3	8	2^9	512	2^{17}	131,072	2^{24}	16,777,216
L	L	H	L	L	2^4	16	2^9	512	2^{17}	131,072	2^{24}	16,777,216
L	L	H	L	H	2^5	32	2^9	512	2^{17}	131,072	2^{24}	16,777,216
L	L	H	H	L	2^6	64	2^9	512	2^{17}	131,072	2^{24}	16,777,216
L	L	H	H	H	2^7	128	2^9	512	2^{17}	131,072	2^{24}	16,777,216
L	H	L	L	L	2^8	256	2^9	512	2^{17}	131,072	2^{22}	4
L	H	L	L	H	2^9	512	2^9	512	2^{17}	131,072	2^2	4
L	H	L	H	L	2^{10}	1,024	2^9	512	2^{17}	131,072	2^4	16
L	H	L	H	H	2^{11}	2,048	2^9	512	2^{17}	131,072	2^4	16
L	H	H	L	L	2^{12}	4,096	2^9	512	2^{17}	131,072	2^6	64
L	H	H	L	H	2^{13}	8,192	2^9	512	2^{17}	131,072	2^6	64
L	H	H	H	L	2^{14}	16,384	2^9	512	Disabled Low		2^8	256
L	H	H	H	H	2^{15}	32,768	2^9	512	Disabled Low		2^8	256
H	L	L	L	L	2^{16}	65,536	2^9	512	2^3	8	2^{10}	1,024
H	L	L	L	H	2^{17}	131,072	2^9	512	2^3	8	2^{10}	1,024
H	L	L	H	L	2^{18}	262,144	2^9	512	2^5	32	2^{12}	4,096
H	L	L	H	H	2^{19}	524,288	2^9	512	2^5	32	2^{12}	4,096
H	L	H	L	L	2^{20}	1,048,576	2^9	512	2^7	128	2^{14}	16,384
H	L	H	L	H	2^{21}	2,097,152	2^9	512	2^7	128	2^{14}	16,384
H	L	H	H	L	2^{22}	4,194,304	Disabled Low		2^9	512	2^{16}	65,536
H	L	H	H	H	2^{23}	8,388,608	Disabled Low		2^9	512	2^{16}	65,536
H	H	L	L	L	2^{24}	16,777,216	2^3	8	2^{11}	2,048	2^{18}	262,144
H	H	L	L	H	2^{25}	33,554,432	2^3	8	2^{11}	2,048	2^{18}	262,144
H	H	L	H	L	2^{26}	67,108,864	2^5	32	2^{13}	8,192	2^{20}	1,048,576
H	H	L	H	H	2^{27}	134,217,728	2^5	32	2^{13}	8,192	2^{20}	1,048,576
H	H	H	L	L	2^{28}	268,435,456	2^7	128	2^{15}	32,768	2^{22}	4,194,304
H	H	H	L	H	2^{29}	536,870,912	2^7	128	2^{15}	32,768	2^{22}	4,194,304
H	H	H	H	L	2^{30}	1,073,741,824	2^9	512	2^{17}	131,072	2^{24}	16,777,216
H	H	H	H	H	2^{31}	2,147,483,648	2^9	512	2^{17}	131,072	2^{24}	16,777,216

TYPES SN54LS292, SN54LS294, SN74LS292, SN74LS294 PROGRAMMABLE FREQUENCY DIVIDERS/DIGITAL TIMERS

'LS294 FUNCTION TABLE

PROGRAMMING INPUTS				FREQUENCY DIVISION			
				Q		TP	
D	C	B	A	BINARY	DECIMAL	BINARY	DECIMAL
L	L	L	L	Inhibit	Inhibit	Inhibit	Inhibit
L	L	L	H	Inhibit	Inhibit	Inhibit	Inhibit
L	L	H	L	2 ²	4	2 ⁹	512
L	L	H	H	2 ³	8	2 ⁹	512
L	H	L	L	2 ⁴	16	2 ⁹	512
L	H	L	H	2 ⁵	32	2 ⁹	512
L	H	H	L	2 ⁶	64	2 ⁹	512
L	H	H	H	2 ⁷	128	Disabled Low	
H	L	L	L	2 ⁸	256	2 ²	4
H	L	L	H	2 ⁹	512	2 ³	8
H	L	H	L	2 ¹⁰	1,024	2 ⁴	16
H	L	H	H	2 ¹¹	2,048	2 ⁵	32
H	H	L	L	2 ¹²	4,096	2 ⁶	64
H	H	L	H	2 ¹³	8,192	2 ⁷	128
H	H	H	L	2 ¹⁴	16,384	2 ⁸	256
H	H	H	H	2 ¹⁵	32,768	2 ⁹	512

switching loads

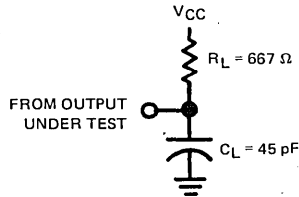
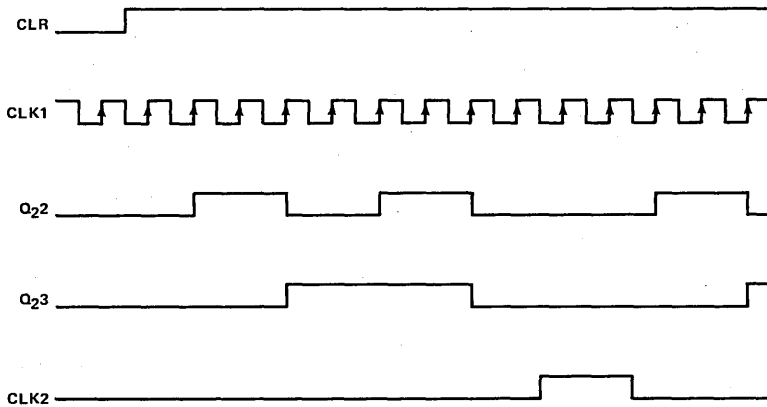

FIGURE 1

'LS292 and 'LS294 timing diagram



3
TTL DEVICES

TYPES SN54LS295B, SN74LS295B 4-BIT RIGHT-SHIFT LEFT-SHIFT REGISTERS WITH 3-STATE OUTPUTS

OCTOBER 1976—REVISED DECEMBER 1983

- 'LS295B Offers Three Times the Sink-Current Capability of 'LS295A
- Schottky-Diode-Clamped Transistors
- Low Power Dissipation . . . 80 mW Typical (Enabled)
- Applications:
 - N-Bit Serial-To-Parallel Converter
 - N-Bit Parallel-To-Serial Converter
 - N-Bit Storage Register

SN54LS295B . . . J OR W PACKAGE
SN74LS295B . . . D, J OR N PACKAGE
(TOP VIEW)

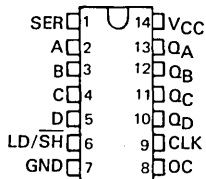

SN54LS295B . . . FK PACKAGE
SN74LS295B . . . FN PACKAGE
(TOP VIEW)

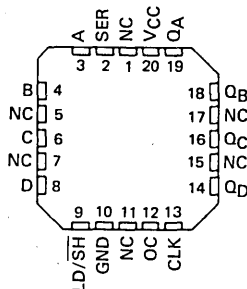

NC - No internal connection

description

These 4-bit registers feature parallel inputs, parallel outputs, and clock (CLK), serial (SER), mode (LD/SH), and outputs control (OC) inputs. The registers have three modes of operation:

- Parallel (broadside) load
- Shift right (the direction Q_A toward Q_D)
- Shift left (the direction Q_D toward Q_A)

Parallel loading is accomplished by applying the four bits of data and taking the mode control input high. The data is loaded into the associated flip-flops and appears at the outputs after the high-to-low transition of the clock input. During parallel loading, the entry of serial data is inhibited.

Shift right is accomplished when the mode control is low; shift left is accomplished when the mode control is high by connecting the output of each flip-flop to the parallel input of the previous flip-flop (Q_D to input C, etc.) and serial data is entered at input D.

When the output control is high, the normal logic levels of the four outputs are available for driving the loads or bus lines. The outputs are disabled independently from the level of the clock by a low logic level at the output control input. The outputs then present a high impedance and neither load nor drive the bus line; however, sequential operation of the registers is not affected.

The SN54LS295B is characterized for operation over the full military temperature range of -55°C to 125°C ; the SN74LS295B is characterized for operation from 0°C to 70°C .

TYPES SN54LS295B, SN74LS295B 4-BIT RIGHT-SHIFT LEFT-SHIFT REGISTERS WITH 3-STATE OUTPUTS

logic diagram

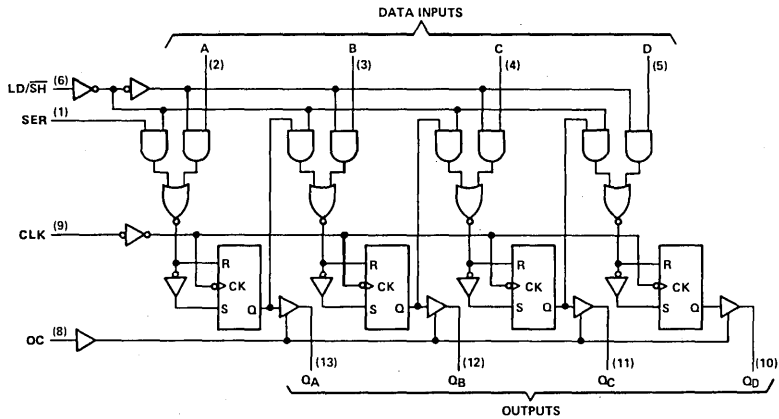

Pin numbers shown on logic notation are for D, J or N packages.

schematics of inputs and outputs

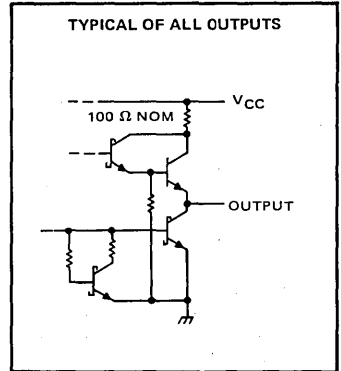
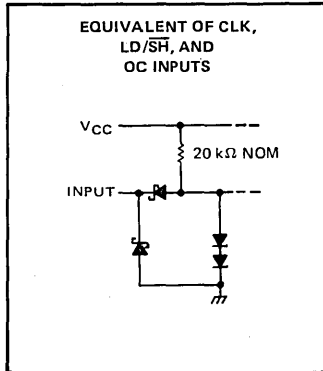
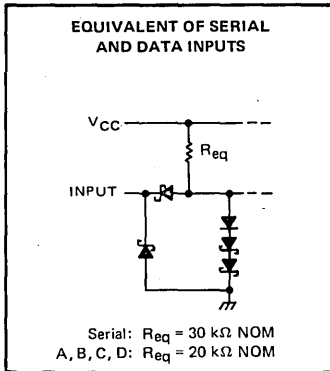

3

TTL DEVICES

TYPES SN54LS295B, SN74LS295B 4-BIT RIGHT-SHIFT LEFT-SHIFT REGISTERS WITH 3-STATE OUTPUTS

FUNCTION TABLE

INPUTS				OUTPUTS						
LD/ \overline{SH}	CLK	SER	PARALLEL				Q _A	Q _B	Q _C	Q _D
			A	B	C	D				
H	H	X	X	X	X	X	Q _{A0}	Q _{B0}	Q _{C0}	Q _{D0}
H	↓	X	a	b	c	d	a	b	c	d
H	↓	X	Q _B †	Q _C †	Q _D †	d	Q _{Bn}	Q _{Cn}	Q _{Dn}	d
L	H	X	X	X	X	X	Q _{A0}	Q _{B0}	Q _{C0}	Q _{D0}
L	↓	H	X	X	X	X	H	Q _{An}	Q _{Bn}	Q _{Cn}
L	↓	L	X	X	X	X	L	Q _{An}	Q _{Bn}	Q _{Cn}

When the output control is low, the outputs are disabled to the high-impedance state; however, sequential operation of the registers is not affected.

†Shifting left requires external connection of Q_B to A, Q_C to B, and Q_D to C. Serial data is entered at input D.

H = high level (steady state), L = low level (steady state), X = irrelevant (any input, including transitions)

↓ = transition from high to low level.

a, b, c, d = the level of steady-state input at inputs A, B, C, or D, respectively.

Q_{A0}, Q_{B0}, Q_{C0}, Q_{D0} = the level of Q_A, Q_B, Q_C, or Q_D, respectively, before the indicated steady-state input conditions were established.

Q_{An}, Q_{Bn}, Q_{Cn}, Q_{Dn} = the level of Q_A, Q_B, Q_C, or Q_D, respectively, before the most-recent ↓ transition of the clock.

absolute maximum ratings over operating free-air temperature range (unless otherwise noted)

Supply voltage, V _{CC} (see Note 1)	7 V
Input voltage	7 V
Operating free-air temperature range: SN54LS295B	-55°C to 125°C
SN74LS295B	0°C to 70°C
Storage temperature range	-65°C to 150°C

NOTE 1: Voltage values are with respect to network ground terminal.

recommended operating conditions

	SN54LS295B			SN74LS295B			UNIT
	MIN	NOM	MAX	MIN	NOM	MAX	
V _{CC} Supply voltage	4.5	5	5.5	4.75	5	5.25	V
I _{OH} High-level output current			-1			-2.6	mA
I _{OL} Low-level output current			12			24	mA
f _{clock} Clock frequency	0		30	0		30	MHz
t _{w(clock)} Width of clock pulse	16			16			ns
t _{su} Setup time, high-level or low-level data	20			20			ns
t _{su} Setup time, LD/ \overline{SH} to CLK	high-level	25		25			ns
	low-level	30		30			
t _h Hold time, high-level or low-level data	5			5			ns
t _h Hold time, high-level or low-level LD/ \overline{SH} to CLK	0			0			ns
T _A Operating free-air temperature	-55		125	0		70	°C

TYPES SN54LS295B, SN74LS295B 4-BIT RIGHT-SHIFT LEFT-SHIFT REGISTERS WITH 3-STATE OUTPUTS

electrical characteristics over recommended operating free-air temperature range (unless otherwise noted)

PARAMETER	TEST CONDITIONS†	SN54LS295B			SN74LS295B			UNIT
		MIN	TYP‡	MAX	MIN	TYP‡	MAX	
V _{IH} High-level input voltage		2			2			V
V _{IL} Low-level input voltage		0.7			0.8			V
V _{IK} Input clamp voltage	V _{CC} = MIN, I _I = -18 mA	-1.5			-1.5			V
V _{OH} High-level output voltage	V _{CC} = MIN, V _{IH} = 2 V, V _{IL} = V _{IL} max, I _{OH} = MAX	2.4	3.4		2.4	3.1		V
V _{OL} Low-level output voltage	V _{CC} = MIN, V _{IH} = 2 V, V _{IL} = V _{IL} max	I _{OL} = 12 mA	0.25	0.4	0.25	0.4		V
		I _{OL} = 24 mA			0.35	0.5		
I _{OZH} Off-state output current, high-level voltage applied	V _{CC} = MAX, V _{IL} = V _{IL} max, V _O = 2.7 V	20			20			μA
I _{OZL} Off-state output current, low-level voltage applied	V _{CC} = MAX, V _{IH} = 2 V, V _O = 0.4 V	-20			-20			μA
I _I Input current at maximum input voltage	V _{CC} = MAX, V _I = 7 V	0.1			0.1			mA
I _{IH} High-level input current	V _{CC} = MAX, V _I = 2.7 V	20			20			μA
I _{IL} Low-level input current	V _{CC} = MAX, V _I = 0.4 V	-0.4			-0.4			mA
I _{OS} Short-circuit output current§	V _{CC} = MAX	-30	-130		-30	-130		mA
I _{CC} Supply current	V _{CC} = MAX, See Note 2	Condition A	20	29	20	29		mA
		Condition B	22	33	22	33		

†For conditions shown as MIN or MAX, use the appropriate value specified under recommended operating conditions.

‡All typical values are at V_{CC} = 5 V, T_A = 25°C.

§Not more than one output should be shorted at a time, and duration of the short-circuit should not exceed one second.

NOTE 2: I_{CC} is measured with the outputs open, the serial input and mode control at 4.5 V, and the data inputs grounded under the following conditions:

- A. Output control at 4.5 V and a momentary 3 V, then ground, applied to clock input.
- B. Output control and clock input grounded.

switching characteristics, V_{CC} = 5 V, T_A = 25 C, R_L = 667 Ω

PARAMETER	TEST CONDITIONS	MIN	TYP	MAX	UNIT
f _{max} Maximum clock frequency	C _L = 45 pF, See Note 3	30	45		MHz
t _{PLH} Propagation delay time, low-to-high-level output		14	20		ns
t _{PHL} Propagation delay time, high-to-low-level output		19	30		ns
t _{PZH} Output enable time to high level		18	26		ns
t _{PZL} Output enable time to low level		20	30		ns
t _{PHZ} Output disable time from high level		C _L = 5 pF, See Note 3	13	20	
t _{PLZ} Output disable time from low level	13		20		ns

NOTE 3: See General Information Section for load circuits and voltage waveforms.

TYPES SN54LS297, SN74LS297 DIGITAL PHASE-LOCKED-LOOP FILTERS

D2629, JANUARY 1981

- Digital Design Avoids Analog Compensation Errors
- Easily Cascadable for Higher Order Loops
- Useful Frequency from DC to:
50 MHz Typical (K Clock)
35 MHz Typical (I/D Clock)

description

The SN54LS297 and SN74LS297 devices are designed to provide a simple, cost-effective solution to high-accuracy, digital, phase-locked-loop applications. These devices contain all the necessary circuits, with the exception of the divide-by-N counter, to build first order phase-locked loops as described in Figure 1.

Both exclusive-OR (XORPD) and edge-controlled (ECPD) phase detectors are provided for maximum flexibility.

Proper partitioning of the loop function, with many of the building blocks external to the package, makes it easy for the designer to incorporate ripple cancellation or to cascade to higher order phase-locked loops.

The length of the up/down K counter is digitally programmable according to the K counter function table. With A, B, C, and D all low, the K counter is disabled. With A high and B, C, and D low, the K counter is only three stages long, which widens the bandwidth or capture range and shortens the lock time of the loop. When A, B, C, and D are all programmed high, the K counter becomes seventeen stages long, which narrows the bandwidth or capture range and lengthens the lock time. Real-time control of loop bandwidth by manipulating the A through D inputs can maximize the overall performance of the digital phase-locked loop.

SN54LS297 ... J OR W PACKAGE
SN74LS297 ... J OR N PACKAGE

(TOP VIEW)

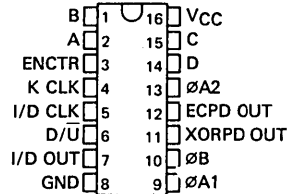

SN54LS297 ... FK PACKAGE
SN74LS297 ... FN PACKAGE

(TOP VIEW)

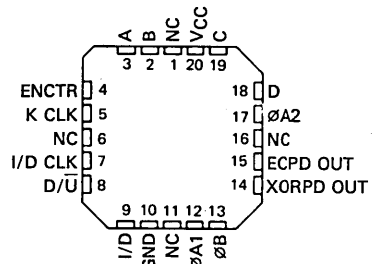

NC—No internal connection

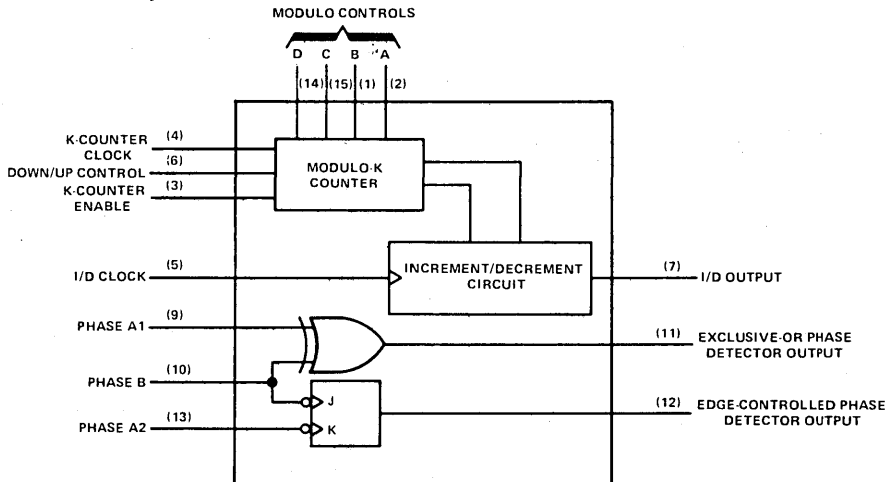

FIGURE 1—SIMPLIFIED BLOCK DIAGRAM

PRODUCTION DATA
This document contains information current as of publication date. Products conform to specifications per the terms of Texas Instruments standard warranty. Production processing does not necessarily include testing of all parameters.

TEXAS
INSTRUMENTS

POST OFFICE BOX 225012 • DALLAS, TEXAS 75285

3-945

TTL DEVICES

TYPES SN54LS297, SN74LS297 DIGITAL PHASE-LOCKED-LOOP FILTERS

description (continued)

The 'LS297 can perform the classic first-order phase-locked loop function without using analog components. The accuracy of the digital phase-locked loop (DPLL) is not affected by V_{CC} and temperature variations, but depends solely on accuracies of the K clock, I/D clock, and loop propagation delays. The I/D clock frequency and the divide-by-N modulus will determine the center frequency of the DPLL. The center frequency is defined by the relationship $f_c = I/D \text{ Clock}/2N \text{ (Hz)}$.

logic diagram

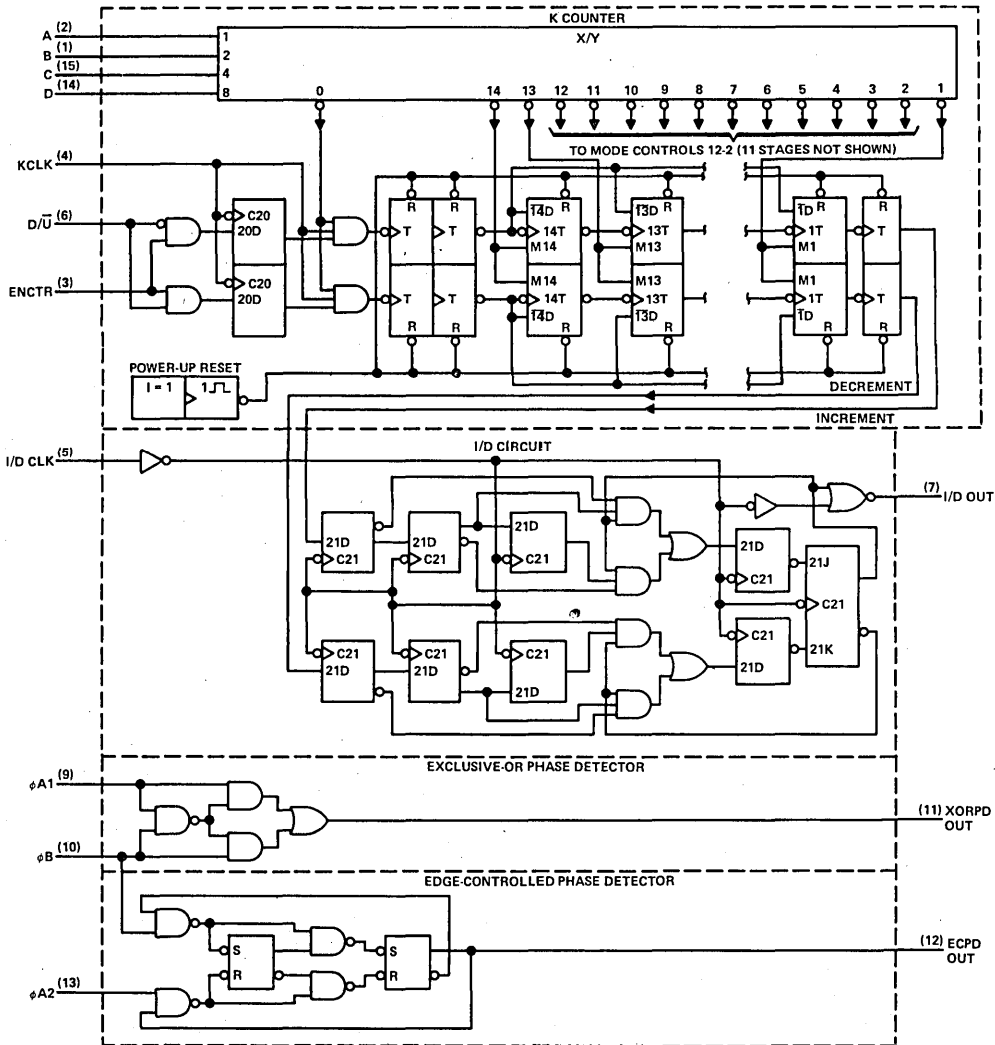

Pin numbers shown on logic notation are for J or N packages.

3 TTL DEVICES

TYPES SN54LS297, SN74LS297 DIGITAL PHASE-LOCKED-LOOP FILTERS

**K COUNTER FUNCTION TABLE
(DIGITAL CONTROL)**

D	C	B	A	MODULO (K)
L	L	L	L	Inhibited
L	L	L	H	23
L	L	H	L	24
L	L	H	H	25
L	H	L	L	26
L	H	L	H	27
L	H	H	L	28
L	H	H	H	29
H	L	L	L	210
H	L	L	H	211
H	L	H	L	212
H	L	H	H	213
H	H	L	L	214
H	H	L	H	215
H	H	H	L	216
H	H	H	H	217

**FUNCTION TABLE
EXCLUSIVE-OR PHASE DETECTOR**

$\phi A1$	ϕB	XORPD OUT
L	L	L
L	H	H
H	L	H
H	H	L

**FUNCTION TABLE
EDGE-CONTROLLED PHASE DETECTOR**

$\phi A2$	ϕB	ECPD OUT
H or L	↓	H
↓	H or L	L
H or L	↑	No change
↑	H or L	No change

H = steady-state high level
L = steady-state low level
↓ = transition from high to low
↑ = transition from low to high

schematics of inputs and outputs

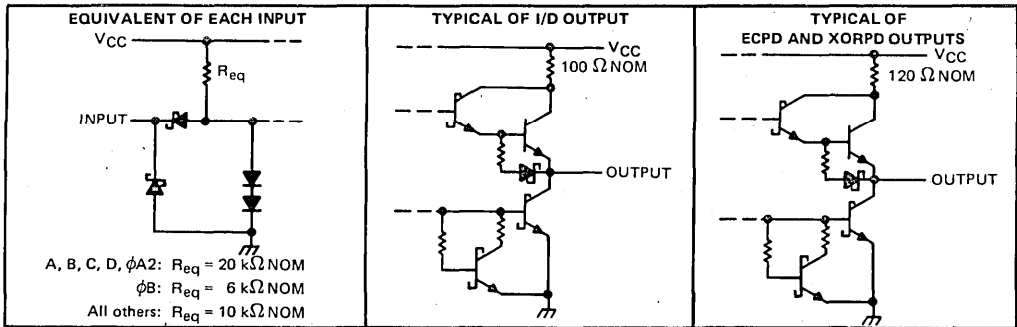

operation

The phase detector generates an error signal waveform that, at zero phase error, is a 50% duty cycle square wave. At the limits of linear operation, the phase detector output will be either high or low all of the time, depending on the direction of the phase error ($\phi_{in} - \phi_{out}$). Within these limits, the phase detector output varies linearly with the input phase error according to the gain k_d , which is expressed in terms of phase detector output per cycle of phase error. The phase detector output can be defined to vary between ± 1 according to the relation:

$$\text{PD Output} = \frac{\% \text{ high} - \% \text{ low}}{100} \quad (1)$$

The output of the phase detector will be $k_d \phi_e$, where the phase error $\phi_e = \phi_{in} - \phi_{out}$.

TTL DEVICES

TYPES SN54LS297, SN74LS297 DIGITAL PHASE-LOCKED-LOOP FILTERS

Exclusive-OR phase detectors (XORPD) and edge-controlled phase detectors (ECPD) are commonly used digital types. The ECPD is more complex than the XORPD logic function, but can be described generally as a circuit that changes states on one of the transitions of its inputs. k_d for an XORPD is 4 because its output remains high (PD output = 1) for a phase error of 1/4 cycle. Similarly, k_d for the ECPD is 2 since its output remains high for a phase error of 1/2 cycle. The type of phase detector will determine the zero-phase-error point, i.e., the phase separation of the phase detector inputs for ϕ_e defined to be zero. For the basic DPLL system of Figure 2, $\phi_e = 0$ when the phase detector output is a square wave. The XORPD inputs are 1/4 cycle out of phase for zero phase error. For the ECPD, $\phi_e = 0$ when the inputs are 1/2 cycle out of phase.

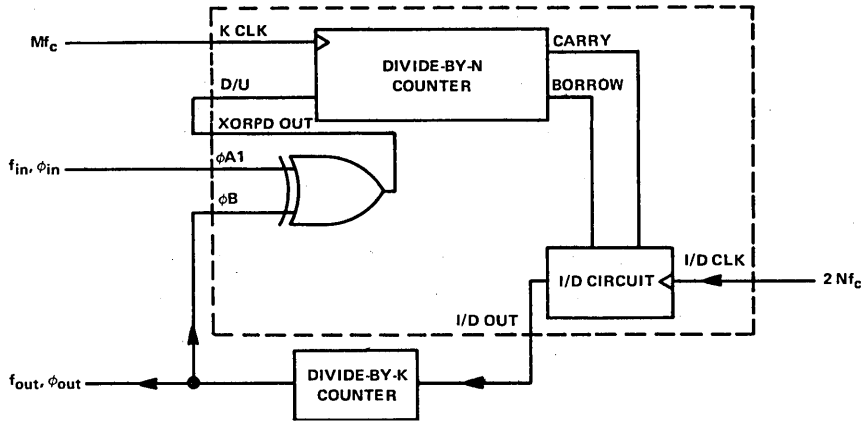

FIGURE 2—DPLL USING EXCLUSIVE-OR PHASE DETECTION

The phase detector output controls the up/down input to the K counter. The counter is clocked by input frequency Mf_c , which is a multiple M of the loop center frequency f_c . When the K counter recycles up, it generates a carry pulse. Recycling while counting down generates a borrow pulse. If the carry and borrow outputs are conceptually combined into one output that is positive for a carry and negative for a borrow, and if the K counter is considered as a frequency divider with the ratio Mf_c/K , the output of the K counter will equal the input frequency multiplied by the division ratio. Thus the output from the K counter is $(k_d \phi_e Mf_c)/K$.

The carry and borrow pulses go to the increment/decrement (I/D) circuit, which, in the absence of any carry or borrow pulse, has an output that is 1/2 of the input clock I/D CLK. The input clock is just a multiple, $2N$, of the loop center frequency. In response to a carry or borrow pulse, the I/D circuit will either add or delete a pulse at I/D OUT. Thus the output of the I/D circuit will be $Nf_c + (k_d \phi_e Mf_c)/2K$.

The output of the N counter (or the output of the phase-locked loop) is thus:

$$f_o = f_c + (k_d \phi_e Mf_c)/2KN$$

If this result is compared to the equation for a first-order analog phase-locked loop, the digital equivalent of the gain of the VCO is just $Mf_c/2KN$ or f_c/K for $M = 2N$.

Thus the simple first-order phase-locked loop with an adjustable K counter is the equivalent of an analog phase-locked loop with a programmable VCO gain.

TYPES SN54LS297, SN74LS297 DIGITAL PHASE-LOCKED-LOOP FILTERS

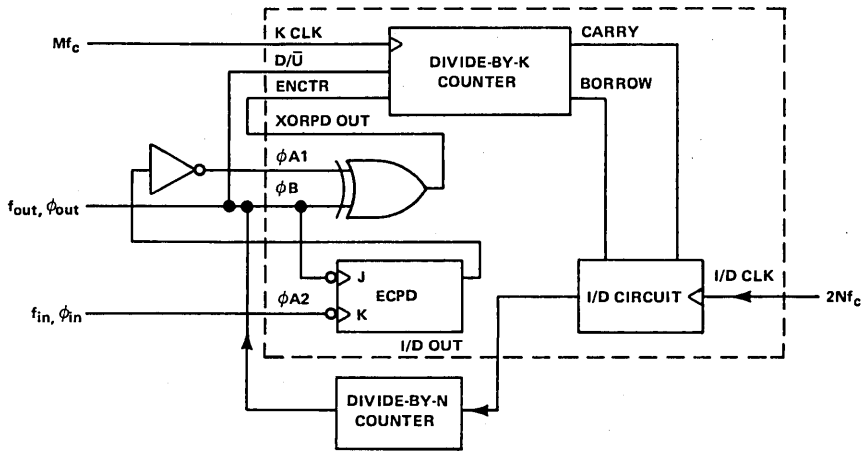

FIGURE 3—DPLL USING BOTH PHASE DETECTORS IN A RIPPLE-CANCELLATION SCHEME

absolute maximum rating over operating free-air temperature range (unless otherwise noted)

Supply voltage, V_{CC} (see Note 1)	7 V
Input voltage	7 V
Operating free-air temperature range: SN54LS297	-55° C to 125° C
SN74LS297	0° C to 70° C
Storage temperature range	-65° C to 150° C

NOTE 1: Voltage values are with respect to network ground terminal.

recommended operating conditions

			SN54LS297			SN74LS297			UNIT
			MIN	NOM	MAX	MIN	NOM	MAX	
V_{CC}	Supply voltage		4.5	5	5.5	4.75	5	5.25	V
I_{OH}	High-level output current	I/D OUT			-1.2			-1.2	mA
		EXOR, ECPD			-400			-400	μ A
I_{OL}	Low-level output current	I/D OUT			12			24	mA
		XOR, ECPD			4			8	mA
f_{clock}	Clock frequency	K Clock	0		32	0		32	MHz
		I/D Clock	0		16	0		16	MHz
t_w	Width of clock input pulse	K Clock	16			16			ns
		I/D Clock	33			33			ns
$t_{su, to K}$	Setup time to K Clock t	U/ \bar{D} , ENCTR	30			30			ns
t_h	Hold time from K Clock t	U/ \bar{D} , ENCTR	0			0			ns
T_A	Operating free-air temperature		-55		125	0		70	°C

3

TTL DEVICES

TYPES SN54LS297, SN74LS297 DIGITAL PHASE-LOCKED-LOOP FILTERS

electrical characteristics over recommended operating free-air temperature range (unless otherwise noted)

PARAMETER	TEST CONDITIONS†	SN54LS297			SN74LS297			UNIT	
		MIN	TYP‡	MAX	MIN	TYP‡	MAX		
V _{IH} High-level input voltage		2			2			V	
V _{IL} Low-level input voltage				0.7			0.8	V	
V _{IK} Input clamp voltage	V _{CC} = MIN, I _I = -18 mA			-1.5			-1.5	V	
V _{OH} High-level output voltage	I/D OUT	V _{CC} = MIN, V _{IH} = 2 V, I _{OH} = MAX	2.4		2.4			V	
	Others	V _{IL} = V _{IL} max, I _{OH} = MAX	2.5		2.7				
V _{OL} Low-level output voltage	I/D OUT	V _{CC} = MIN, V _{IH} = 2 V, I _{OL} = 12 mA		0.25	0.4		0.25	0.4	V
		V _{IL} = V _{IL} max, I _{OL} = 24 mA					0.35	0.5	
	Others	V _{CC} = MIN, V _{IH} = 2 V, I _{OL} = 4 mA		0.25	0.4		0.25	0.4	
		V _{IL} = V _{IL} max, I _{OL} = 8 mA					0.35	0.5	
I _I Input current at maximum input voltage	V _{CC} = MAX, V _I = 7 V			0.1			0.1	mA	
I _{IH} High-level input current	U/D, EN, φA†	V _{CC} = MAX, V _I = 2.7 V			40		40	μA	
	φB				60		60		
	All others				20		20		
I _{IL} Low-level input current	U/D, EN, φA†	V _{CC} = MAX, V _I = 0.4 V			-0.8		-0.8	mA	
	φB				-1.2		-1.2		
	All others				-0.4		-0.4		
I _{OS} Short-circuit output current §	I/D OUT	V _{CC} = MAX	-30	-130	-30	-130		mA	
	Others		-20	-100	-20	-100			
I _{CC} Supply current	V _{CC} = MAX, All inputs grounded, All outputs open		75	120		75	120	mA	

† For conditions shown as MIN or MAX, use the appropriate value specified under recommended operating conditions.

‡ All typical values are of V_{CC} = 5 V, T_A = 25°C.

§ Not more than one output should be shorted at a time and the duration of the short-circuit should not exceed one second.

switching characteristics, V_{CC} = 5 V, T_A = 25°C

PARAMETER¶	FROM (INPUT)		TO (OUTPUT)	TEST CONDITIONS	MIN	TYP	MAX	UNIT
f _{max}	KCLK		I/D OUT	R _L = 667 Ω, C _L = 45 pF, See Note 2	32	50		MHz
	I/D CLK		I/D OUT		16	35		
t _{PLH}	I/D CLK †		I/D OUT	See Note 2		15	25	ns
t _{PHL}	I/D CLK †		I/D OUT			22	35	ns
t _{PLH}	φA1 or φB	Other input low	XOR OUT	R _L = 2 k Ω, C _L = 45 pF, See Note 2		10	15	ns
	φA1 or φB	Other input high	XOR OUT			17	25	
t _{PHL}	φA1 or φB	Other input low	XOR OUT			15	25	ns
	φA1 or φB	Other input high	XOR OUT			17	25	
t _{PLH}	φB †		ECPD OUT			20	30	ns
t _{PHL}	φA2 †		ECPD OUT			20	30	ns

¶ t_{PLH} = propagation delay time, low-to-high level output

t_{PHL} = propagation delay time, high-to-low level output

NOTE 2: See General Information Section for load circuits and voltage waveforms.

TYPES SN54298, SN54LS298, SN74298, SN74LS298 QUADRUPLE 2-INPUT MULTIPLEXERS WITH STORAGE

MARCH 1974 — REVISED DECEMBER 1983

- **Selects One of Two 4-Bit Data Sources and Stores Data Synchronously with System Clock**
- **Applications:**
Dual Source for Operands and Constants in Arithmetic Processor; Can Release Processor Register Files for Acquiring New Data

Implement Separate Registers Capable of Parallel Exchange of Contents Yet Retain External Load Capability

Universal Type Register for Implementing Various Shift Patterns; Even Has Compound Left-Right Capabilities

description

These monolithic quadruple two-input multiplexers with storage provide essentially the equivalent functional capabilities of two separate MSI functions (SN54157/SN74157 or SN54LS157/SN74LS157 and SN54175/SN74175 or SN54LS175/SN74LS175) in a single 16-pin package.

When the word-select input is low, word 1 (A1, B1, C1, D1) is applied to the flip-flops. A high input to word select will cause the selection of word 2 (A2, B2, C2, D2). The selected word is clocked to the output terminals on the negative-going edge of the clock pulse.

Typical power dissipation is 195 milliwatts for the '298 and 65 milliwatts for the 'LS298. SN54298 and SN54LS298 are characterized for operation over the full military temperature range of -55°C to 125°C ; SN74298 and SN74LS298 are characterized for operation from 0°C to 70°C .

SN54298, SN54LS298 ... J OR W PACKAGE
SN74298 ... J OR N PACKAGE
SN74LS298 ... D, J OR N PACKAGE
(TOP VIEW)

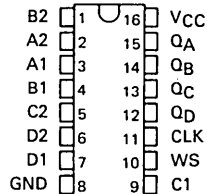

SN54LS298 ... FK PACKAGE
SN74LS298 ... FN PACKAGE
(TOP VIEW)

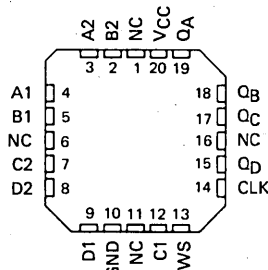

NC - No internal connection

FUNCTION TABLE

INPUTS		OUTPUTS			
WORD SELECT	CLOCK	Q _A	Q _B	Q _C	Q _D
L	↓	a1	b1	c1	d1
H	↓	a2	b2	c2	d2
X	H	Q _{A0}	Q _{B0}	Q _{C0}	Q _{D0}

H = high level (steady state)
L = low level (steady state)
X = irrelevant (any input, including transitions)
↓ = transition from high to low level
a1, a2, etc. = the level of steady-state input at A1, A2, etc.
Q_{A0}, Q_{B0}, etc. = the level of Q_A, Q_B, etc. entered on the most-recent ↓ transition of the clock input.

PRODUCTION DATA

This document contains information current as of publication date. Products conform to specifications per the terms of Texas Instruments standard warranty. Production processing does not necessarily include testing of all parameters.

TEXAS
INSTRUMENTS

POST OFFICE BOX 225012 • DALLAS, TEXAS 75265

3

TTL DEVICES

TYPES SN54298, SN54LS298, SN74298, SN74LS298 QUADRUPLE 2-INPUT MULTIPLEXERS WITH STORAGE

logic diagram

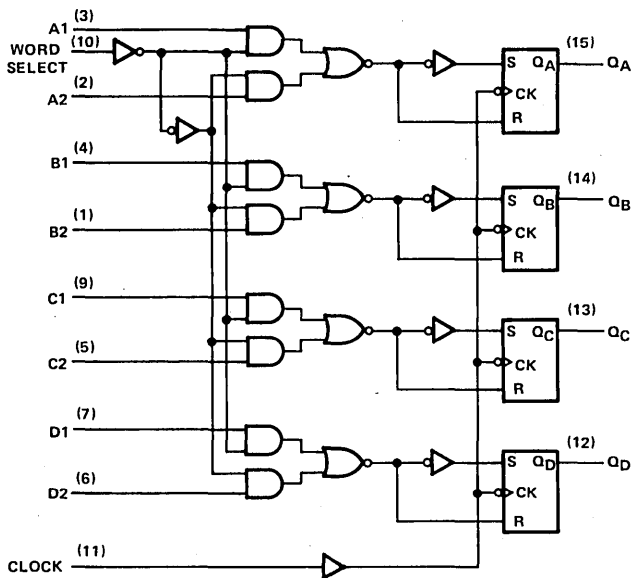

Pin numbers shown on logic notation are for D, J or N packages.

3

schematics of inputs and outputs

TTL DEVICES

'298

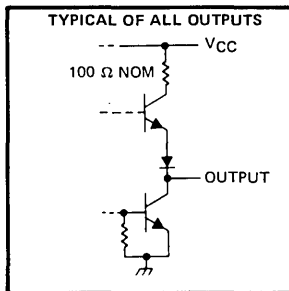
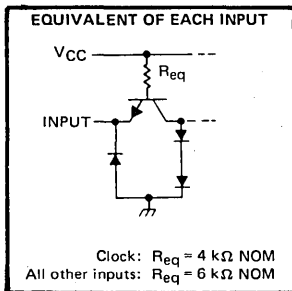

'LS298

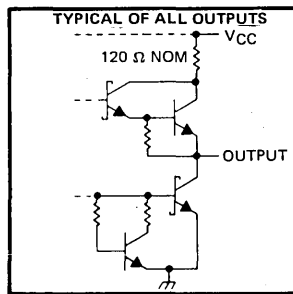
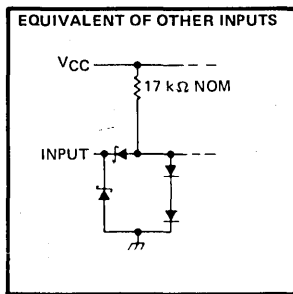
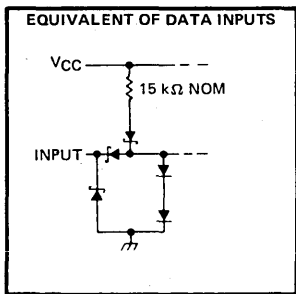

TYPES SN54298, SN74298 QUADRUPLE 2-INPUT MULTIPLEXERS WITH STORAGE

absolute maximum ratings over operating free-air temperature range (unless otherwise noted)

Supply voltage, V_{CC} (see Note 1)	7 V
Input voltage	5.5 V
Operating free-air temperature range: SN54298	-55°C to 125°C
SN74298	0°C to 70°C
Storage temperature	-65°C to 150°C

NOTE 1: Voltage values are with respect to network ground terminal.

recommended operating conditions

		SN54298			SN74298			UNIT
		MIN	NOM	MAX	MIN	NOM	MAX	
Supply voltage, V_{CC}		4.5	5	5.5	4.75	5	5.25	V
High-level output current, I_{OH}		-800			-800			μ A
Low-level output current, I_{OL}		16			16			mA
Width of clock pulse, high or low level, t_w		20			20			ns
Setup time, t_{SU}	Data	15			15			ns
	Word select	25			25			
Hold time, t_H	Data	5			5			ns
	Word select	0			0			
Operating free-air temperature, T_A		-55			125			0
								70
								°C

electrical characteristics over recommended operating free-air temperature range (unless otherwise noted)

PARAMETER	TEST CONDITIONS†	MIN	TYP‡	MAX	UNIT
V_{IH} High-level input voltage		2			V
V_{IL} Low-level input voltage				0.8	V
V_{IK} Input clamp voltage	$V_{CC} = \text{MIN}, I_I = -12 \text{ mA}$			-1.5	V
V_{OH} High-level output voltage	$V_{CC} = \text{MIN}, V_{IH} = 2 \text{ V}, V_{IL} = 0.8 \text{ V}, I_{OH} = -800 \mu\text{A}$	2.4	3.2		V
V_{OL} Low-level output voltage	$V_{CC} = \text{MIN}, V_{IH} = 2 \text{ V}, V_{IL} = 0.8 \text{ V}, I_{OL} = 16 \text{ mA}$			0.4	V
I_I Input current at maximum input voltage	$V_{CC} = \text{MAX}, V_I = 5.5 \text{ V}$			1	mA
I_{IH} High-level input current	$V_{CC} = \text{MAX}, V_I = 2.4 \text{ V}$			40	μ A
I_{IL} Low-level input current	$V_{CC} = \text{MAX}, V_I = 0.4 \text{ V}$			-1.6	mA
I_{OS} Short-circuit output current §	$V_{CC} = \text{MAX}$			-20	mA
				-18	
I_{CC} Supply current	$V_{CC} = \text{MAX},$ See Note 2			39	mA
				65	

†For conditions shown as MIN or MAX, use the appropriate value specified under recommended operating conditions.

‡All typical values are at $V_{CC} = 5 \text{ V}, T_A = 25^\circ\text{C}$.

§Not more than one output should be shorted at a time.

NOTE 2: With all outputs open and all inputs except clock low, I_{CC} is measured after applying a momentary 4.5 V, followed by ground, to the clock input.

switching characteristics, $V_{CC} = 5 \text{ V}, T_A = 25^\circ\text{C}$

PARAMETER	TEST CONDITIONS	MIN	TYP	MAX	UNIT
t_{PLH} Propagation delay time, low-to-high-level output	$C_L = 15 \text{ pF}, R_L = 400 \Omega,$	18		27	ns
t_{PHL} Propagation delay time, high-to-low-level output	See Note 3	21		32	

NOTE 3: See General Information Section for load circuits and voltage waveforms.

TYPES SN54LS298, SN74LS298

QUADRUPLE 2-INPUT MULTIPLEXERS WITH STORAGE

absolute maximum ratings over operating free-air temperature range (unless otherwise noted)

Supply voltage, V_{CC} (see Note 1)	7 V
Input voltage	7 V
Operating free-air temperature range: SN54LS298	-55°C to 125°C
SN74LS298	0°C to 70°C
Storage temperature range	-65°C to 150°C

NOTE 1: Voltage values are with respect to network ground terminal.

recommended operating conditions

	SN54LS298			SN74LS298			UNIT
	MIN	NOM	MAX	MIN	NOM	MAX	
Supply voltage, V_{CC}	4.5	5	5.5	4.75	5	5.25	V
High-level output current, I_{OH}	-400			-400			μ A
Low-level output current, I_{OL}	4			8			mA
Width of clock pulse, high or low level, t_w	20			20			ns
Setup time, t_{su}	Data	15		15			ns
	Word select	25		25			
Hold time, t_h	Data	5		5			ns
	Word select	0		0			
Operating free-air temperature, T_A	-55		125	0		70	°C

electrical characteristics over recommended operating free-air temperature range (unless otherwise noted)

PARAMETER	TEST CONDITIONS [†]	SN54LS298			SN74LS298			UNIT
		MIN	TYP [‡]	MAX	MIN	TYP [‡]	MAX	
V_{IH} High-level input voltage		2			2			V
V_{IL} Low-level input voltage		0.7			0.8			V
V_{IK} Input clamp voltage	$V_{CC} = \text{MIN}$, $I_I = -18 \text{ mA}$	-1.5			-1.5			V
V_{OH} High-level output voltage	$V_{CC} = \text{MIN}$, $V_{IH} = 2 \text{ V}$, $V_{IL} = V_{IL \text{ max}}$, $I_{OH} = -400 \mu\text{A}$	2.5	3.4		2.7	3.4		V
V_{OL} Low-level output voltage	$V_{CC} = \text{MIN}$, $V_{IH} = 2 \text{ V}$, $V_{IL} = V_{IL \text{ max}}$	$I_{OL} = 4 \text{ mA}$		0.25	0.4	0.25	0.4	V
		$I_{OL} = 8 \text{ mA}$				0.35	0.5	
I_I Input current at maximum input voltage	$V_{CC} = \text{MAX}$, $V_I = 7 \text{ V}$	0.1			0.1			mA
I_{IH} High-level input current	$V_{CC} = \text{MAX}$, $V_I = 2.7 \text{ V}$	20			20			μ A
I_{IL} Low-level input current	$V_{CC} = \text{MAX}$, $V_I = 0.4 \text{ V}$	-0.4			-0.4			mA
I_{OS} Short-circuit output current [§]	$V_{CC} = \text{MAX}$	-20		-100	-20		-100	mA
I_{CC} Supply current	$V_{CC} = \text{MAX}$, See Note 2	13		21	13		21	mA

[†]For conditions shown as MIN or MAX, use the appropriate value specified under recommended operating conditions.

[‡]All typical values are at $V_{CC} = 5 \text{ V}$, $T_A = 25^\circ\text{C}$.

[§]Not more than one output should be shorted at a time, and duration of the short-circuit should not exceed one second.

NOTE 2: With all outputs open and all inputs except clock low, I_{CC} is measured after applying a momentary 4.5 V, followed by ground, to the clock input.

switching characteristics, $V_{CC} = 5 \text{ V}$, $T_A = 25^\circ\text{C}$

PARAMETER	TEST CONDITIONS	MIN	TYP	MAX	UNIT
t_{PLH} Propagation delay time, low-to-high-level output	$C_L = 15 \text{ pF}$, $R_L = 2 \text{ k}\Omega$,		18	27	ns
t_{PHL} Propagation delay time, high-to-low-level output	See Note 3		21	32	

NOTE 3: See General Information Section for load circuits and voltage waveforms.

3

TTL DEVICES

TYPES SN54298, SN54LS298, SN74298, SN74LS298 QUADRUPLE 2-INPUT MULTIPLEXERS WITH STORAGE

TYPICAL APPLICATION DATA

This versatile multiplexer/register can be connected to operate as a shift register that can shift N-places in a single clock pulse.

The following figure illustrates a BCD shift register that will shift an entire 4-bit BCD digit in one clock pulse.

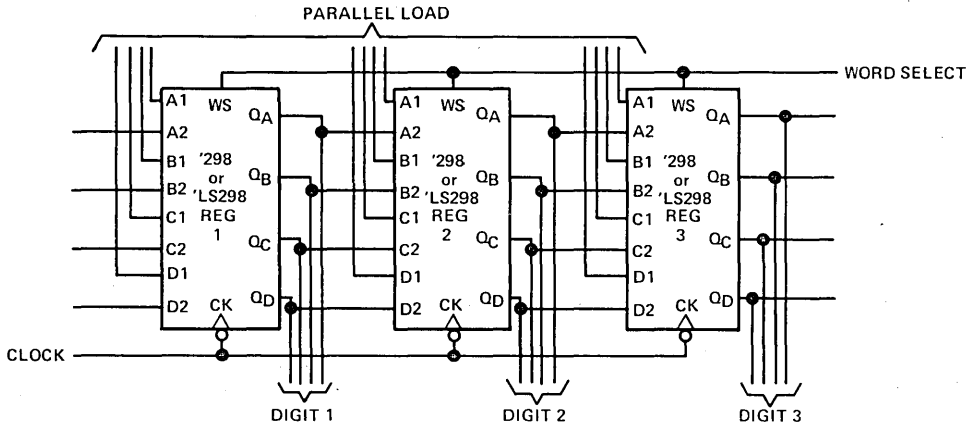

When the word-select input is high and the registers are clocked, the contents of register 1 is transferred (shifted) to register 2 and etc. In effect, the BCD digits are shifted one position. In addition, this application retains a parallel-load capability which means that new BCD data can be entered in the entire register with one clock pulse. This arrangement can be modified to perform the shifting of binary data for any number of bit locations.

Another function that can be implemented with the '298 or 'LS298 is a register that can be designed specifically for supporting multiplier or division operations. The example below is a one place/two-place shift register.

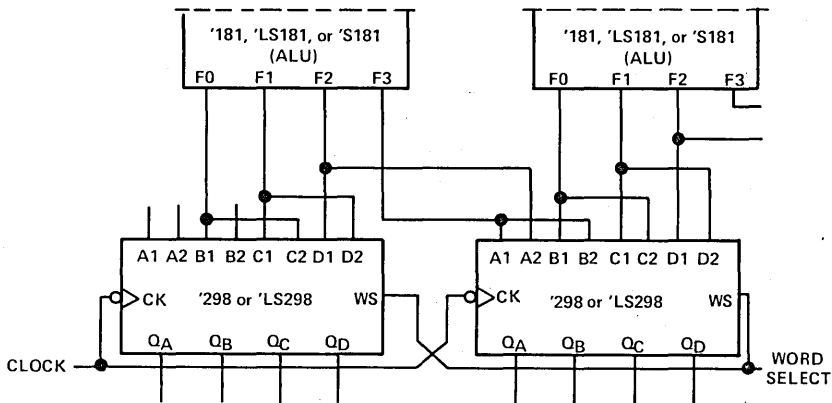

When word select is low and the register is clocked, the outputs of the arithmetic/logic units (ALU's) are shifted one place. When word select is high and the registers are clocked, the data is shifted two places.

3

TTL DEVICES

3

TTL DEVICES

TYPES SN54LS299, SN54S299, SN74LS299, SN74S299 8-BIT UNIVERSAL SHIFT/STORAGE REGISTERS

MARCH 1974 — REVISED APRIL 1985

- **Multiplexed Inputs/Outputs Provide Improved Bit Density**
- **Four Modes of Operations:**

Hold (Store)	Shift Left
Shift Right	Load Data
- **Operates with Outputs Enabled or at High Z**
- **3-State Outputs Drive Bus Lines Directly**
- **Can Be Cascaded for N-Bit Word Lengths**
- **SN54LS323 and SN74LS323 Are Similar But Have Synchronous Clear**
- **Applications:**
Stacked or Push-Down Registers
Buffer Storage, and Accumulator Registers

TYPE	GUARANTEED SHIFT (CLOCK) FREQUENCY	TYPICAL POWER DISSIPATION
'LS299	25 MHz	175 mW
'S299	50 MHz	700 mW

SN54LS299, SN54S299 . . . J OR W PACKAGE
SN74LS299, SN74S299 . . . DW, J OR N PACKAGE

(TOP VIEW)

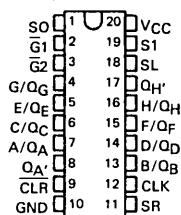

SN54LS299, SN54S299 . . . FK PACKAGE
SN74LS299, SN74S299 . . . FN PACKAGE

(TOP VIEW)

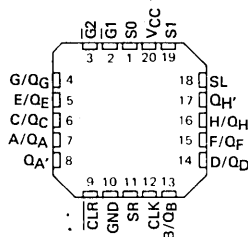

description

These Schottky TTL eight-bit universal registers feature multiplexed inputs/outputs to achieve full eight-bit data handling in a single 20-pin package. Two function-select inputs and two output-control inputs can be used to choose the modes of operation listed in the function table.

Synchronous parallel loading is accomplished by taking both function-select lines, S0 and S1, high. This places the three-state outputs in a high-impedance state, which permits data that is applied on the input/output lines to be clocked into the register. Reading out of the register can be accomplished while the outputs are enabled in any mode. A direct overriding input is provided to clear the register whether the outputs are enabled or off.

FUNCTION TABLE

MODE	CLR	INPUTS				CLK	SERIAL SL SR	INPUTS/OUTPUTS								OUTPUTS			
		FUNCTION SELECT		OUTPUT CONTROL				A/QA	B/QB	C/QC	D/QD	E/QE	F/QF	G/QG	H/QH	QA'	QH'		
		S1	S0	G1†	G2†														
Clear	L	X	L	L	L	X	X	X	X	L	L	L	L	L	L	L	L	L	L
	L	L	X	L	L	X	X	X	X	L	L	L	L	L	L	L	L	L	L
Hold	H	L	L	L	L	X	X	X	X	QA0	QB0	QC0	QD0	QE0	QF0	QG0	QH0	QA0	QH0
	H	X	X	L	L	L	X	X	X	QA0	QB0	QC0	QD0	QE0	QF0	QG0	QH0	QA0	QH0
Shift Right	H	L	H	L	L	†	X	H	H	QA _n	QB _n	QC _n	QD _n	QE _n	QF _n	QG _n	QH _n	H	QG _n
	H	L	H	L	L	†	X	L	L	QA _n	QB _n	QC _n	QD _n	QE _n	QF _n	QG _n	QH _n	L	QG _n
Shift Left	H	H	L	L	L	†	H	X	H	QB _n	QC _n	QD _n	QE _n	QF _n	QG _n	QH _n	H	QB _n	H
	H	H	L	L	L	†	L	X	L	QB _n	QC _n	QD _n	QE _n	QF _n	QG _n	QH _n	L	QB _n	L
Load	H	H	H	X	X	†	X	X	a	b	c	d	e	f	g	h	a	h	

†When one or both output controls are high the eight input/output terminals are disabled to the high-impedance state; however, sequential operation or clearing of the register is not affected.

a . . . h = the level of the steady-state input at inputs A through H, respectively. These data are loaded into the flip-flops while the flip-flop outputs are isolated from the input/output terminals.

PRODUCTION DATA
This document contains information current as of publication date. Products conform to specifications per the terms of Texas Instruments standard warranty. Production processing does not necessarily include testing of all parameters.

TEXAS INSTRUMENTS

POST OFFICE BOX 225012 • DALLAS, TEXAS 75265

3-957



TTL DEVICES

TYPES SN54LS299, SN54S299, SN74LS299, SN74S299
8-BIT UNIVERSAL SHIFT/STORAGE REGISTERS

logic diagram

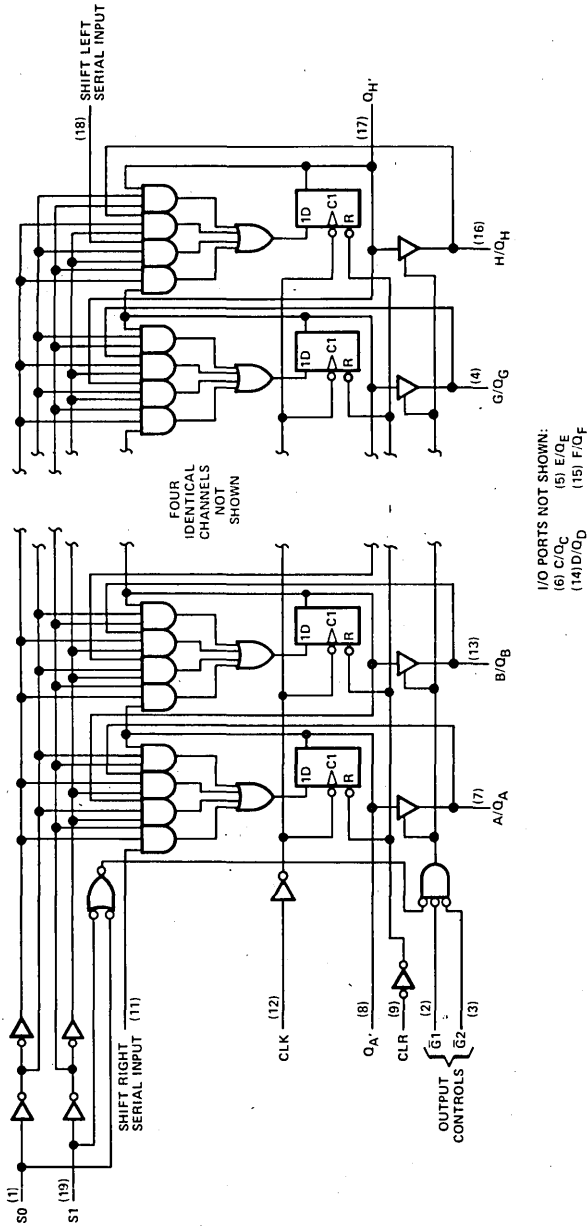

Pin numbers shown on logic notation are for DW, J or N packages.

TYPES SN54LS299, SN74LS299 8-BIT UNIVERSAL SHIFT/STORAGE REGISTERS

schematics of inputs and outputs

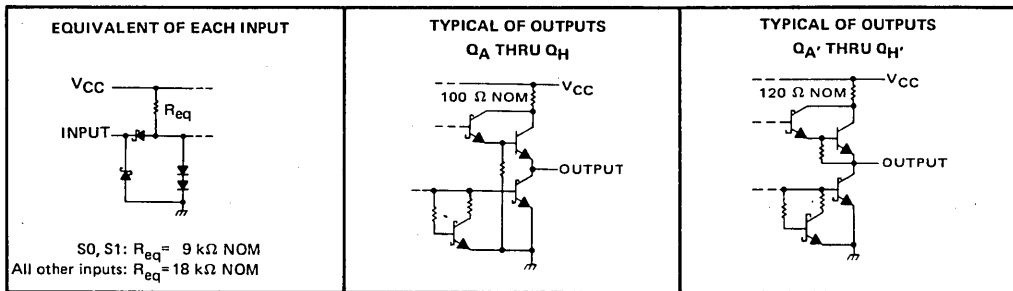

absolute maximum ratings over operating free-air temperature range (unless otherwise noted)

Supply voltage, V_{CC} (see Note 1)	7 V
Input voltage	7 V
Off-state output voltage	5.5 V
Operating free-air temperature range: SN54LS299	-55°C to 125°C
SN74LS299	0°C to 70°C
Storage temperature	-65°C to 150°C

NOTE 1: Voltage values are with respect to network ground terminal.

recommended operating conditions

		SN54LS299			SN74LS299			UNIT		
		MIN	NOM	MAX	MIN	NOM	MAX			
Supply voltage, V_{CC}		4.5	5	5.5	4.75	5	5.25	V		
High-level output current, I_{OH}	Q_A thru Q_H	-1			-2.6			mA		
	Q_A' or Q_H'	-0.4			-0.4					
Low-level output current, I_{OL}	Q_A thru Q_H	12			24			mA		
	Q_A' or Q_H'	4			8					
Clock frequency, f_{clock}		0			20			MHz		
Width of clock pulse, $t_w(\text{clock})$	Clock high	30			30			ns		
	Clock low	10			10					
Width of clear pulse, $t_w(\text{clear})$		20			20			ns		
Setup time, t_{SU}	Select	35†			35†			ns		
	High-level data [◇]	20†			20†					
	Low-level data [◇]	20†			20†					
	Clear inactive-state	20†			20†					
Hold time, t_H	Select	10†			10†			ns		
	Data [◇]	0†			0†					
Operating free-air temperature, T_A		-55			125			0	70	°C

[◇]Data includes the two serial inputs and the eight input/output data lines.

3
TTL DEVICES

TYPES SN54LS299, SN74LS299 8-BIT UNIVERSAL SHIFT/STORAGE REGISTERS

electrical characteristics over recommended operating free-air temperature range (unless otherwise noted)

PARAMETER		TEST CONDITIONS†	SN54LS299			SN74LS299			UNIT
			MIN	TYP‡	MAX	MIN	TYP‡	MAX	
V _{IH}	High-level input voltage		2			2			V
V _{IL}	Low-level input voltage					0.7			V
V _{IK}	Input clamp voltage	V _{CC} = MIN, I _I = -18 mA				-1.5			V
V _{OH}	High-level output voltage	Q _A thru Q _H	V _{CC} = MIN, V _{IH} = 2 V,		2.4	3.2	2.4	3.1	V
		Q _{A'} or Q _{H'}	V _{IL} = V _{ILmax} , I _{OH} = MAX		2.5	3.4	2.7	3.4	
V _{OL}	Low-level output voltage	Q _A thru Q _H	V _{CC} = MIN, V _{IH} = 2 V, V _{IL} = V _{ILmax}	I _{OL} = 12 mA	0.25	0.4	0.25	0.4	V
				I _{OL} = 24 mA			0.35	0.5	
		Q _{A'} or Q _{H'}	I _{OL} = 4 mA	0.25	0.4	0.25	0.4		
			I _{OL} = 8 mA			0.35	0.5		
I _{OZH}	Off-state output current, high-level voltage applied	Q _A thru Q _H	V _{CC} = MAX, V _O = 2.7 V, V _{IH} = 2 V,	40			40	μA	
I _{OZL}	Off-state output current, low-level voltage applied	Q _A thru Q _H	V _{CC} = MAX, V _O = 0.4 V, V _{IH} = 2 V,	-400			-400	μA	
I _I	Input current at maximum input voltage	S0, S1	V _{CC} = MAX	V _I = 7 V	200			200	μA
		A thru H		V _I = 5.5 V	100			100	
		Any other		V _I = 7 V	100			100	
I _{IH}	High-level input current	A thru H, S0, S1	V _{CC} = MAX, V _I = 2.7 V	40			40	μA	
		Any other		20			20		
I _{IL}	Low-level input current	S0, S1	V _{CC} = MAX, V _I = 0.4 V	-0.8			-0.8	mA	
		Any other		-0.4			-0.4		
							-0.4		-0.4
I _{OS}	Short-circuit output current§	Q _A thru Q _H	V _{CC} = MAX	-30	-130	-30	-130	mA	
		Q _{A'} or Q _{H'}		-20	-100	-20	-100		
I _{CC}	Supply current		V _{CC} = MAX	33	53	33	53	mA	

† For conditions shown as MIN or MAX, use the appropriate value specified under recommended operating conditions.

‡ All typical values are at V_{CC} = 5 V, T_A = 25°C.

§ Not more than one output should be shorted at a time and duration of the short-circuit should not exceed one second.

switching characteristics, V_{CC} = 5 V, T_A = 25°C

PARAMETER¶	FROM (INPUT)	TO (OUTPUT)	TEST CONDITIONS	MIN	TYP	MAX	UNIT
f _{max}			See Note 2	20	35		MHz
t _{PLH}	CLK	Q _{A'} or Q _{H'}	R _L = 2 kΩ, C _L = 15 pF	22	33		ns
t _{PHL}				26	39		
t _{PHL}	CL _R	Q _{A'} or Q _{H'}		27	40		ns
t _{PLH}	CLK	Q _A thru Q _H	R _L = 665 Ω, C _L = 45 pF	17	25		ns
t _{PHL}				26	39		
t _{PHL}	CL _R	Q _A thru Q _H		26	40		ns
t _{PZH}	G ₁ , G ₂	Q _A thru Q _H		13	21		ns
t _{PZL}				19	30		
t _{PHZ}	G ₁ , G ₂	Q _A thru Q _H	R _L = 665 Ω, C _L = 5 pF	10	20		ns
t _{PLZ}				10	15		

¶ f_{max} = maximum clock frequency

t_{PLH} = propagation delay time, low-to-high-level output.

t_{PHL} = propagation delay time, high-to-low-level output

t_{PZH} = output enable time to high level

t_{PZL} = output enable time to low level

t_{PHZ} = output disable time from high level

t_{PLZ} = output disable time from low level

NOTE 2: For testing f_{max}, all outputs are loaded simultaneously, each with C_L and R_L as specified for the propagation times.

See General Information Section for load circuits and voltage waveforms.

3

TTL DEVICES

TYPES SN54S299, SN74S299 8-BIT UNIVERSAL SHIFT/STORAGE REGISTERS

schematics of inputs and outputs

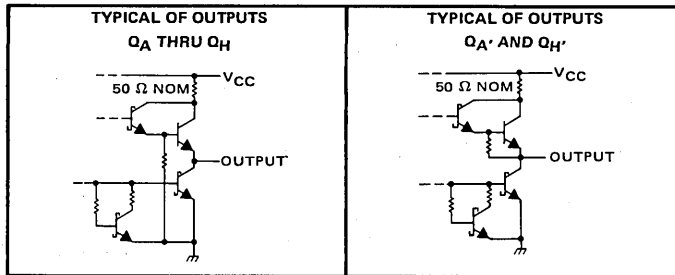
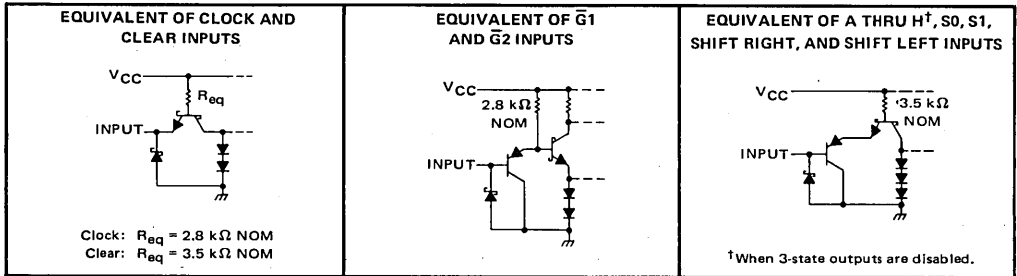

absolute maximum ratings over operating free-air temperature range (unless otherwise noted)

Supply voltage, V_{CC} (see Note 1)	7 V
Input voltage	5.5 V
Off-state output voltage	5.5 V
Operating free-air temperature range: SN54S299 (see Note 2)	-55°C to 125°C
SN74S299	0°C to 70°C
Storage temperature	-65°C to 150°C

NOTE 1: Voltage values are with respect to network ground terminal.

recommended operating conditions

		SN54S299			SN74S299			UNIT
		MIN	NOM	MAX	MIN	NOM	MAX	
Supply voltage, V_{CC}		4.5	5	5.5	4.75	5	5.25	V
High-level output current, I_{OH}	Q_A thru Q_H			-2			-6.5	mA
	Q_A' or Q_H'			-0.5			-0.5	
Low-level output current, I_{OL}	Q_A thru Q_H			20			20	mA
	Q_A' or Q_H'			6			6	
Clock frequency, f_{clock}		0		50	0		50	MHz
Width of clock pulse, $t_{w(clock)}$	Clock high	10			10			ns
	Clock low	10			10			
Width of clear pulse, $t_{w(clear)}$	Clear low	10			10			ns
Setup time, t_{su}	Select	15†			15†			ns
	High-level data [◊]	7†			7†			
	Low-level data [◊]	5†			5†			
	Clear inactive-state	10†			10†			
Hold time, t_h	Select	5†			5†			ns
	Data [◊]	5†			5†			
Operating free-air temperature, T_A		-55		125	0		70	°C

[◊]Data includes the two serial inputs and the eight input/output data lines.

3

TTL DEVICES

TYPES SN54S299, SN74S299

8-BIT UNIVERSAL SHIFT/STORAGE REGISTERS

electrical characteristics over recommended operating free-air temperature range (unless otherwise noted)

PARAMETER		TEST CONDITIONS†	MIN	TYP‡	MAX	UNIT	
V _{IH}	High-level input voltage		2			V	
V _{IL}	Low-level input voltage				0.8	V	
V _{IK}	Input clamp voltage	V _{CC} = MIN, I _I = -18 mA			-1.2	V	
V _{OH}	High-level output voltage	Q _A thru Q _H	V _{CC} = MIN, V _{IH} = 2 V,	2.4	3.2	V	
		Q _{A'} or Q _{H'}	V _{IL} = 0.8 V, I _{OH} = MAX	2.7	3.4		
V _{OL}	Low-level output voltage	V _{CC} = MIN, V _{IH} = 2 V, V _{IL} = 0.8 V, I _{OL} = MAX			0.5	V	
I _{OZH}	Off-state output current, high-level voltage applied	Q _A thru Q _H V _{CC} = MAX, V _{IH} = 2 V, V _O = 2.4 V			100	μA	
I _{OZL}	Off-state output current, low-level voltage applied	Q _A thru Q _H V _{CC} = MAX, V _{IH} = 2 V, V _O = 0.5 V			-250	μA	
I _I	Input current at maximum input voltage	V _{CC} = MAX, V _I = 5.5 V			1	mA	
I _{IH}	High-level input current	A thru H, S ₀ , S ₁	V _{CC} = MAX, V _I = 2.7 V		100	μA	
		Any other			50		
I _{IL}	Low-level input current	CLK or CLR	V _{CC} = MAX, V _I = 0.5 V		-2	mA	
		S ₀ , S ₁			-500	μA	
		Any other			-250	μA	
		Q _A thru Q _H Q _{A'} or Q _{H'}	V _{CC} = MAX		-40	-100	mA
I _{OS}	Short-circuit output current§	Q _A thru Q _H Q _{A'} or Q _{H'}	V _{CC} = MAX		-20	-100	mA
I _{CC}	Supply current	V _{CC} = MAX			140	225	mA

† For conditions shown as MIN or MAX, use the appropriate value specified under recommended operating conditions.

‡ All typical values are at V_{CC} = 5 V, T_A = 25°C.

§ Not more than one output should be shorted at a time and duration of the short-circuit should not exceed one second.

switching characteristics, V_{CC} = 5 V, T_A = 25°C

PARAMETER¶	FROM (INPUT)	TO (OUTPUT)	TEST CONDITIONS	MIN	TYP	MAX	UNIT	
f _{max}			See Note 2	50	70		MHz	
t _{PLH}	CLK	Q _{A'} or Q _{H'}	R _L = 1 kΩ, C _L = 15 pF			12	20	ns
t _{PHL}						13	20	
t _{PHL}	CLR	Q _{A'} or Q _{H'}	R _L = 280 Ω, C _L = 45 pF			14	21	ns
t _{PLH}	CLK	Q _A thru Q _H				15	21	ns
t _{PHL}						15	21	
t _{PHL}	CLR	Q _A thru Q _H				16	24	ns
t _{PZH}	G ₁ , G ₂	Q _A thru Q _H	R _L = 280 Ω, C _L = 5 pF			10	18	ns
t _{PZL}						12	18	
t _{PHZ}	G ₁ , G ₂	Q _A thru Q _H				7	12	ns
t _{PLZ}						7	12	

¶ f_{max} = maximum clock frequency

t_{PLH} = Propagation delay time, low-to-high-level output

t_{PHL} = Propagation delay time, high-to-low-level output

t_{PZH} = output enable time to high level

t_{PZL} = output enable time to low level

t_{PHZ} = output disable time from high level

t_{PLZ} = output disable time from low level

NOTE 2: For testing f_{max}, all outputs are loaded simultaneously, each with C_L and R_L as specified for the propagation times.

See General Information Section for load circuits and voltage waveforms.

TYPES SN54LS320, SN54LS321, SN74LS320, SN74LS321 CRYSTAL-CONTROLLED OSCILLATORS

D2418, DECEMBER 1978—REVISED JANUARY 1981

'LS320

- Crystal-Controlled Oscillator Operation from 1 MHz to 20 MHz
- 2-Phase Driver Outputs

'LS321

- Similar to 'LS320 But Includes $f/2$ and $f/4$ Count-Down Outputs

description

The 'LS320 is a crystal-controlled oscillator/clock driver. It features complementary standard and high-current driver outputs. A synchronization flip-flop is included.

The driver outputs, F' and \bar{F}' have very-low impedance and can be used to drive highly capacitive TTL-level lines. If the driver outputs are not used, then the V_{CC}' terminal can be left open.

The 'LS321 is identical to the 'LS320 except it additionally features two count-down outputs, $F/2$ and $F/4$.

These circuits were designed for crystal control of frequency and capacitive control is not recommended. If a fundamental crystal is used, an inductor of 5 to 160 μH is required to be connected between the tank 1 and tank 2 inputs. †

Interaction of the driver outputs with the other outputs limits useful frequencies as shown in the frequency-limits table.

The SN54LS320 and SN54LS321 are characterized for operation over the full military temperature range of -55°C to 125°C . The SN74LS320 and SN74LS321 are characterized for operation from 0°C to 70°C .

logic symbols

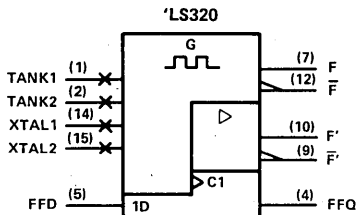

SN54LS320 ... J PACKAGE
SN74LS320 ... J OR N PACKAGE
(TOP VIEW)

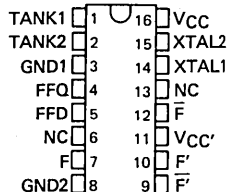

SN54LS321 ... J PACKAGE
SN74LS321 ... J OR N PACKAGE
(TOP VIEW)

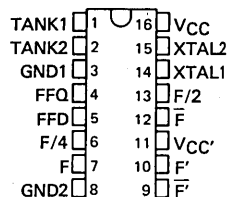

NC — No internal connection.

For chip carrier information,
contact the factory.

FREQUENCY LIMITS

OUTPUTS IN USE	V_{CC}	V_{CC}'	f_{max}
Driver outputs only	5 V	5 V	20 MHz
Other outputs only	5 V	Open	20 MHz
Driver and any other outputs	5 V	5 V	10 MHz

'LS321

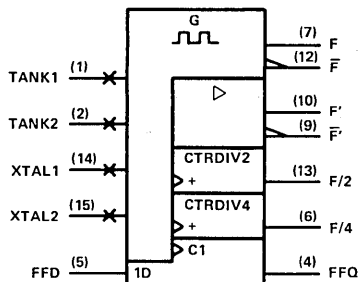

†The value of the inductor is selected from the graph in Figure 2. Use the next higher standard inductor value if the selected value is not available. If a third overtone crystal is used, a tuned tank is necessary. The center frequency of the tuned tank is determined by the equation $f = \frac{1}{2} \pi \sqrt{LC}$.

PRODUCTION DATA
This document contains information current as of publication date. Products conform to specifications per the terms of Texas Instruments standard warranty. Production processing does not necessarily include testing of all parameters.

TEXAS
INSTRUMENTS

POST OFFICE BOX 225012 • DALLAS, TEXAS 75265

3-963

3

TTL DEVICES

TYPES SN54LS320, SN54LS321, SN74LS320, SN74LS321 CRYSTAL-CONTROLLED OSCILLATORS

logic diagram (positive logic)

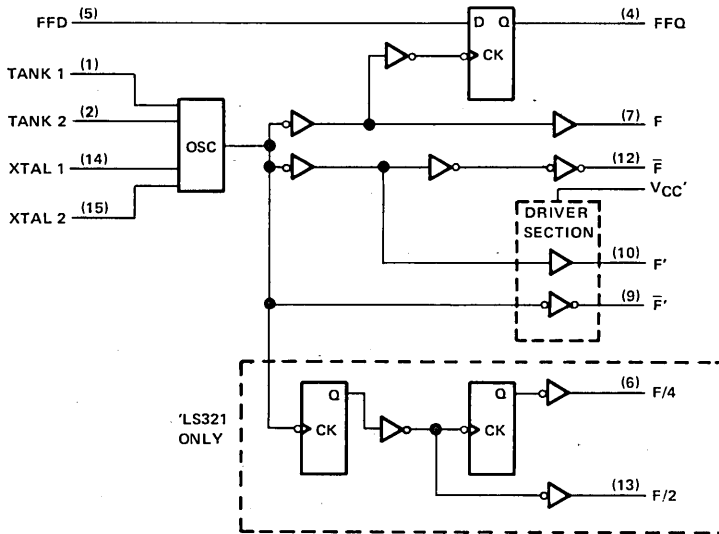

Pin numbers shown on logic notation are for J or N packages.

absolute maximum ratings over operating free-air temperature range (unless otherwise noted)

Supply voltage, V_{CC} (see Note 1)	7 V
Supply voltage, V_{CC}'	7 V
Input voltage to FFD terminal	-0.5 V to 7 V
Operating free-air temperature range: SN54LS320, SN54LS321	-55°C to 125°C
SN74LS320, SN74LS321	0°C to 70°C
Storage temperature range	-65°C to 150°C

NOTE 1: Voltage values are with respect to network ground terminals.

recommended operating conditions

	SN54LS320 SN54LS321			SN74LS320 SN74LS321			UNIT
	MIN	NOM	MAX	MIN	NOM	MAX	
Supply voltage, V_{CC}	4.5	5	5.5	4.75	5	5.25	V
Supply voltage, V_{CC}'	4.5	5	5.5	4.75	5	5.25	V
High-level output current, I_{OH}	F' or \bar{F}'		-12			-24	mA
	$F, \bar{F}, F/2, F/4$		-0.4			-0.4	
Low-level output current, I_{OL}	F' or \bar{F}'		12			24	mA
	$F, \bar{F}, F/2, F/4$		4			8	
Output frequency, f_{out}	$F/2$ ('LS321)	0.5	10	0.5		10	MHz
	$F/4$ ('LS321)	0.25	5	0.25		5	
	F or \bar{F}	1	20	1		20	
Operating free-air temperature, T_A	-55		125	0		70	°C

Input and output schematics are similar to those shown for SN74LS326.

3 TTL DEVICES

TYPES SN54LS320, SN54LS321, SN74LS320, SN74LS321 CRYSTAL-CONTROLLED OSCILLATORS

electrical characteristics over recommended operating free-air temperature range (unless otherwise noted)

PARAMETER	TEST CONDITIONS†	SN54LS320 SN54LS321		SN74LS320 SN74LS321		UNIT		
		MIN	TYP‡	MAX	MIN		TYP‡	MAX
V _{IH}	High-level input voltage	2		2		V		
V _{IL}	Low-level input voltage			0.7		V		
V _{IK}	Input clamp voltage	V _{CC} = MIN, V _{CC} ' = MIN, I _I = -18 mA		-1.5		V		
V _{OH}	High-level output voltage	F', F̄'	V _{CC} = 4.5 V, V _{CC} ' = 4.5 V, I _{OH} = -12 mA	2.5	3.3	V		
		Others	V _{CC} = 4.75 V, V _{CC} ' = 4.75 V, I _{OH} = -24 mA	2.7	3.3			
V _{OL}	Low-level output voltage	F', F̄'	V _{CC} = MIN, V _{CC} ' = MIN, I _{OL} = 12 mA	0.25	0.4	0.25	0.4	
			I _{OL} = 24 mA			0.35	0.5	
		Others	V _{CC} = MIN, V _{IH} = 2 V, I _{OL} = 4 mA	0.25	0.4	0.25	0.4	
			I _{OL} = 8 mA			0.35	0.5	
I _I	Input current at maximum input voltage	V _{CC} = MAX, V _I = 7 V		0.1		mA		
I _{IH}	High-level input current	V _{CC} = MAX, V _I = 2.7 V		20		μA		
I _{IL}	Low-level input current	V _{CC} = MAX, V _I = 0.4 V		-0.4		mA		
I _{OS}	Short-circuit output current§	V _{CC} = MAX		-20	-100	-20	-100	mA
I _{CC}	Supply current from V _{CC}	V _{CC} = MAX, FFD at GND	'LS320	42	70	42	70	mA
			'LS321	47	75	47	75	
I _{CC} '	Supply current from V _{CC} '	V _{CC} = MAX, V _{CC} ' = MAX, FFD at GND		4	8	4	8	mA

† For conditions shown as MIN or MAX, use the appropriate value specified under recommended operating conditions.

‡ All typical values are at V_{CC} = 5 V, V_{CC}' = 5 V, and T_A = 25°C.

§ Not more than one output should be shorted at a time, and duration of the short-circuit should not exceed one second. Outputs F' and F̄' do not have short-circuit protection and these limits do not apply.

switching characteristics, V_{CC} = 5 V, V_{CC}' = 5 V, T_A = 25°C

PARAMETER	OUTPUTS	TEST CONDITIONS		'LS320			'LS321			UNIT
				MIN	TYP	MAX	MIN	TYP	MAX	
f _{max}	F/2	C _L = 100 pF	R _L = 667 Ω				10 15			MHz
	F/4						5 7.5			
	All others			20 30			20 30			
t _r	F', F̄'	C _L = 50 pF	R _L = 667 Ω	6 12			6 12			ns
		C _L = 100 pF		7 14			7 14			
		C _L = 200 pF		7 14			7 14			
	Others	C _L = 50 pF	R _L = 2 kΩ	11 22			11 22			
		C _L = 100 pF		25 40			25 40			
C _L = 200 pF	45 70			45 70						
t _f	F', F̄'	C _L = 50 pF	R _L = 667 Ω	5 10			5 10			ns
		C _L = 100 pF		5 10			5 10			
		C _L = 200 pF		6 12			6 12			
	Others	C _L = 50 pF	R _L = 2 kΩ	6 12			6 12			
		C _L = 100 pF		10 20			10 20			
		C _L = 200 pF		17 30			17 30			

¶ See General Information Section for load circuits and voltage waveforms.



TYPES SN54LS320, SN54LS321, SN74LS320, SN74LS321 CRYSTAL-CONTROLLED OSCILLATORS

TYPICAL APPLICATION DATA

The SN54/74LS320 and 'LS321 are crystal-controlled oscillators. Figure 1 shows the device with all required external components.

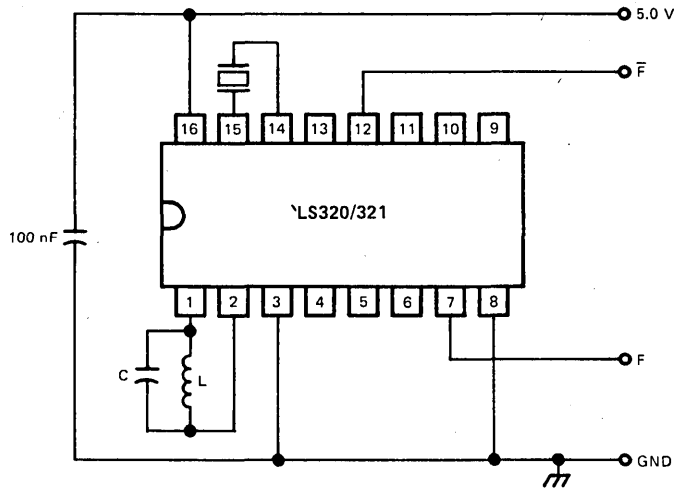

FIGURE 1. CRYSTAL-CONTROLLED OSCILLATOR 'LS320/321

1. Determination of C and L are as follows:
 - a. Inductance L
Select Inductance L according to Figure 2.
 - b. Capacitor C

$$C = C_S - C_p - C_L$$

- Where:
- C_p = parasitic board capacitance
 - C_L = parasitic capacitance of the inductor
 - L = inductance
 - C_S = required capacitance calculated as follows:

$$C_S = \frac{1}{(2 \cdot \pi \cdot f_q)^2 \cdot L}$$

for $f_q > 12$ MHz, $C = 0$ pf

2. Electrical characteristic for the crystal:
The quartz crystal used as a frequency reference should be designed for series mode operation with a resistance in the 20 Ω to 75 Ω range and be capable of a minimum 2 mw power dissipation. It is recommended to use a tuned tank also for fundamental crystals.

3

TTL DEVICES

TYPES SN54LS320, SN54LS321, SN74LS320, SN74LS321
CRYSTAL-CONTROLLED OSCILLATORS

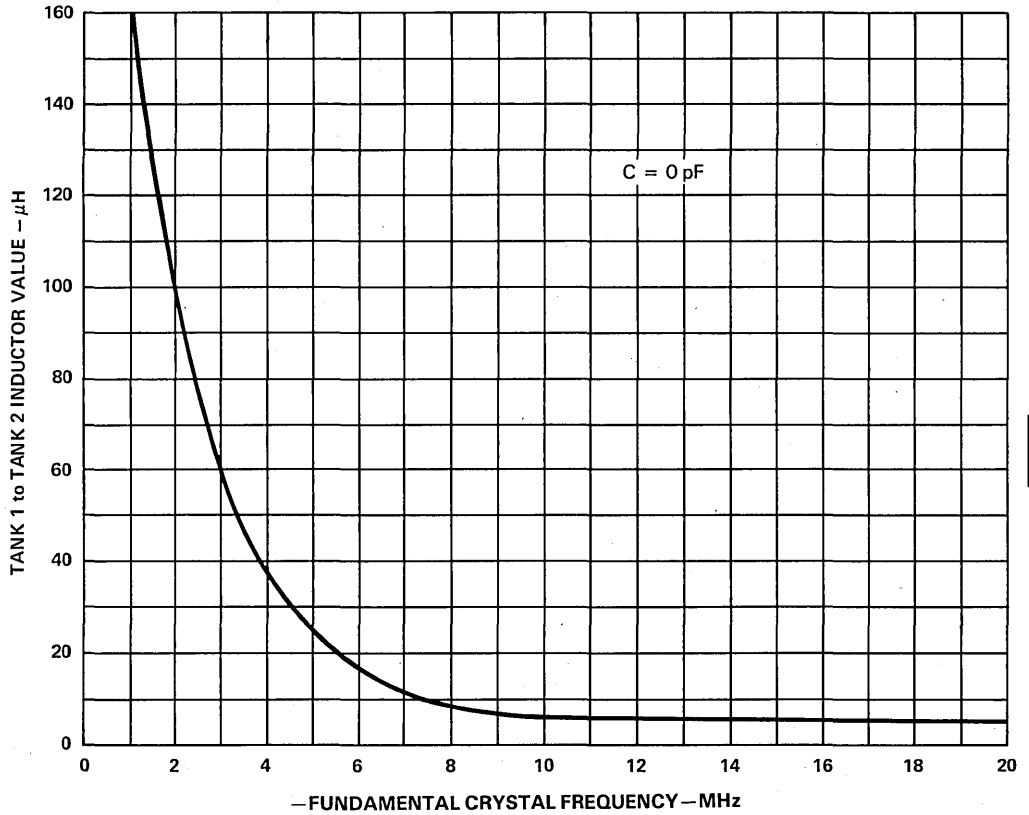

FIGURE 2

3

TTL DEVICES

3

TTL DEVICES

3-968

TEXAS 
INSTRUMENTS
POST OFFICE BOX 225012 • DALLAS, TEXAS 75265

TYPES SN54LS322A, SN74LS322A 8-BIT SHIFT REGISTERS WITH SIGN EXTEND

D2411, OCTOBER 1977—REVISED APRIL 1985

- **Multiplexed Inputs/Outputs Provide Improved Bit Density**
- **3-State Outputs Drive Bus Lines Directly**
- **Sign Extend Function**
- **Direct Overriding Clear**

description

These low-power Schottky eight-bit shift registers feature multiplexed input/output data ports to achieve full eight-bit data handling in a single 20-pin package. Serial data may be entered into the shift-right register through either the D0 or the D1 input as selected by the data select input. A serial output (QH') is also provided to facilitate expansion. Synchronous parallel loading is accomplished by taking both the register enable and the S/P inputs low. This places the three-state input/output ports in the data input mode. Data are entered on the low-to-high transition of the clock. The data extend function repeats the sign in the QA flip-flop during shifting. A direct overriding clear input clears the internal registers when taken low whether the outputs are enabled or off. The output enable does not interfere with synchronous operation of the register.

SN54LS322A ... J PACKAGE
SN74LS322A ... DW, J OR N PACKAGE
(TOP VIEW)

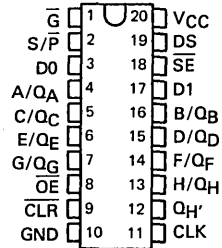

SN54LS322A ... FK PACKAGE
SN74LS322A ... FN PACKAGE
(TOP VIEW)

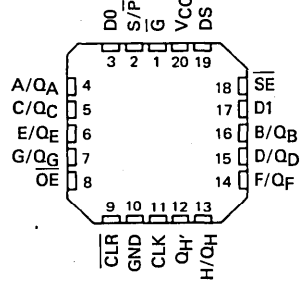

FUNCTION TABLE

OPERATION	INPUTS							INPUTS/OUTPUTS					OUTPUT QH'
	CLR	REGISTER ENABLE G	S/P	SIGN EXTEND SE	DATA SELECT DS	OUTPUT ENABLE OE	CLK	A/QA	B/QB	C/QC...H/QH	QH'		
Clear	L	H	X	X	X	L	X	L	L	L	L	L	
	L	X	H	X	X	L	X	L	L	L	L	L	
Hold	H	H	X	X	X	L	X	QA0	QB0	QC0	QH0	QH0	
	H	L	H	H	L	L	†	D0	QA _n	QB _n	QC _n	QH _n	
Shift Right	H	L	H	H	H	L	†	D1	QA _n	QB _n	QC _n	QH _n	
	H	L	H	L	X	L	†	QA _n	QA _n	QB _n	QC _n	QH _n	
Sign Extend	H	L	H	L	X	L	†	QA _n	QA _n	QB _n	QC _n	QH _n	
Load	H	L	L	X	X	X	†	a	b	c	h	h	

When the output enable is high, the eight input/output terminals are disabled to the high-impedance state; however, sequential operation or clearing of the register is not affected. If both the register enable input and the S/P input are low while the clear input is low, the register is cleared while the eight input/output terminals are disabled to the high-impedance state.

H = high level (steady state)

L = low level (steady state)

X = irrelevant (any input, including transitions)

† = transition from low to high level

QA0 ... QH0 = the level of QA through QH, respectively, before the indicated steady-state conditions were established

QA_n ... QH_n = the level of QA through QH, respectively, before the most recent † transition of the clock

D0, D1 = the level of steady-state inputs at inputs D0 and D1 respectively

a ... h = the level of steady-state inputs at inputs A through H respectively

PRODUCTION DATA
This document contains information current as of publication date. Products conform to specifications per the terms of Texas Instruments standard warranty. Production processing does not necessarily include testing of all parameters.

**TEXAS
INSTRUMENTS**

POST OFFICE BOX 225012 • DALLAS, TEXAS 75265

TYPES SN54LS332A, SN74LS322A
8-BIT SHIFT REGISTERS WITH SIGN EXTEND

Logic diagram (positive logic)

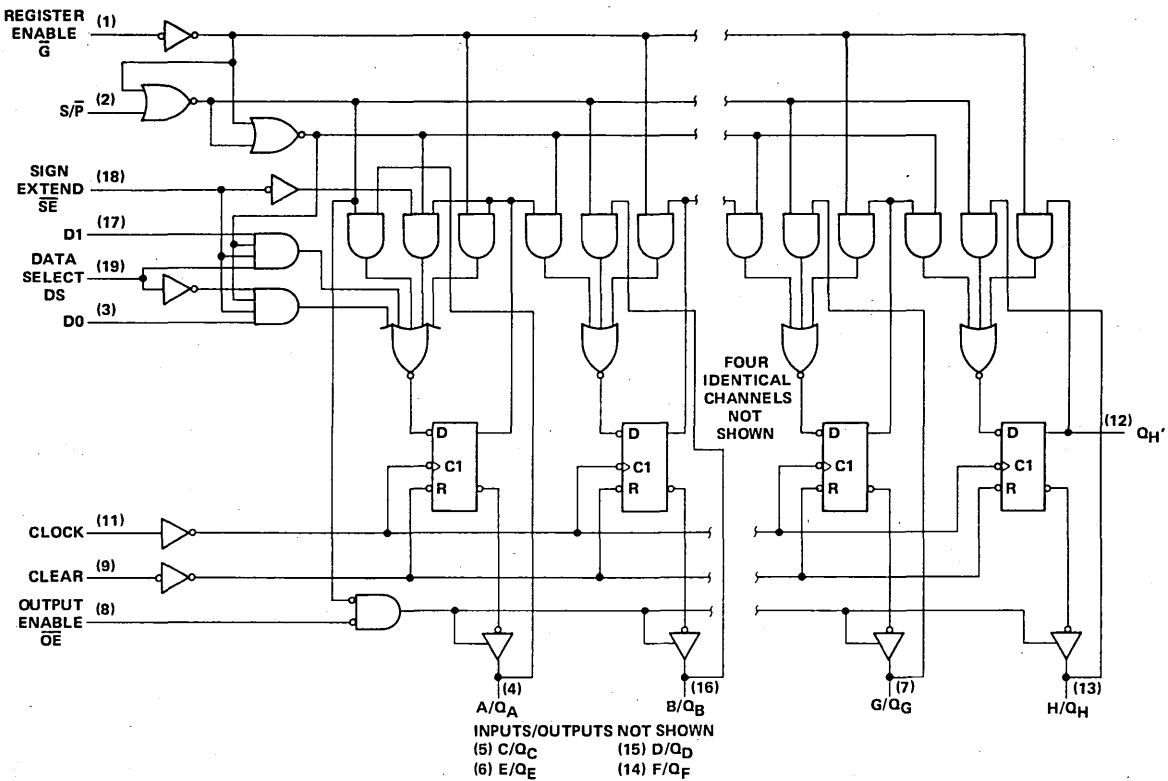

Pin numbers shown on logic notation are for DW, J or N packages.

TYPES SN54LS322A, SN74LS322A 8-BIT SHIFT REGISTERS WITH SIGN EXTEND

logic symbol

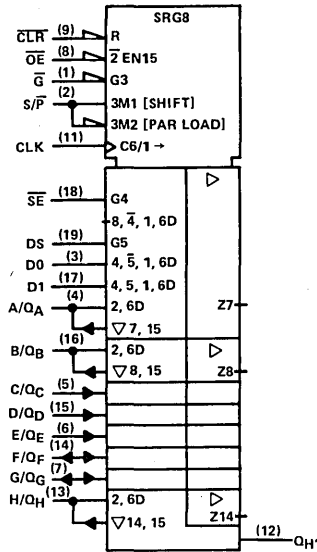

Pin numbers shown on logic notation are for DW, J or N packages.

schematics of inputs and outputs

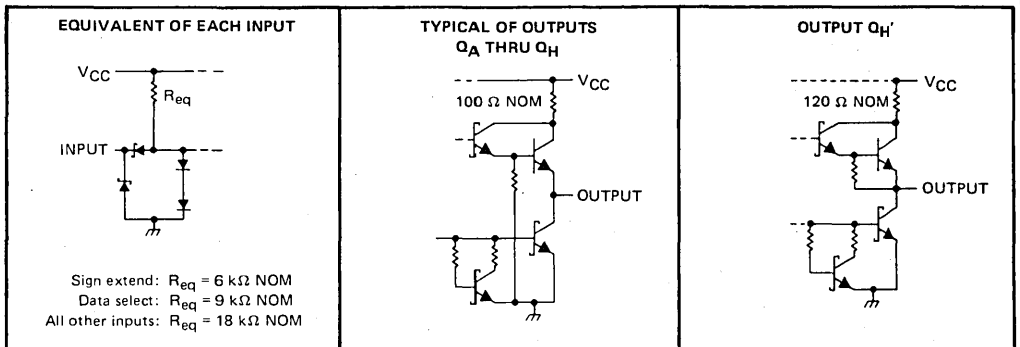

3
TTL DEVICES

TYPES SN54LS322A, SN74LS322A

8-BIT SHIFT REGISTERS WITH SIGN EXTEND

absolute maximum ratings over operating free-air temperature range (unless otherwise noted)

Supply voltage, V_{CC} (see Note 1)	7 V
Input voltage	7 V
Off-state output voltage	7 V
Operating free-air temperature range: SN54LS322A	-55°C to 125°C
SN74LS322A	0°C to 70°C
Storage temperature	-65°C to 150°C

NOTE 1: Voltage values are with respect to network ground terminal.

recommended operating conditions

		SN54LS322A			SN74LS322A			UNIT
		MIN	NOM	MAX	MIN	NOM	MAX	
V_{CC}	Supply voltage	4.5	5	5.5	4.75	5	5.25	V
V_{IH}	High-level input voltage	2			2			V
V_{IL}	Low-level input voltage			0.7			0.8	V
I_{OH}	High-level output current	Q_A thru Q_H		-1			-2.6	mA
		Q_H'		-0.4			-0.4	
I_{OL}	Low-level output current	Q_A thru Q_H		12			24	mA
		Q_H'		4			8	
				0	20	0	20	
f_{clock}	Clock frequency	0		20	0		20	MHz
$t_{w(clock)}$	Width of clock pulse	Clock high	30		30			ns
		Clock low	10		10			
$t_{w(clear)}$	Clear low	20			20			ns
t_{su}	Setup time	Data select	10 †		10 †			ns
		High-level data [◇]	20 †		20 †			
		Low-level data [◇]	20 †		20 †			
		Clear inactive-state	20 †		20 †			
		Register enable high	35		35			
		Register enable low	50		50			
t_h	Hold time	Data select	10 †		10 †			ns
		Data [◇]	2.0 †		2.0 †			
		Register enable high or low	0		0			
T_A	Operating free-air temperature	-55		125	0		70	°C

[◇]Data includes the two serial inputs and the eight input/output data lines.

† The arrow indicates that the rising edge of the clock pulse is used for reference.

3 TTL DEVICES

TYPES SN54LS322A, SN74LS322A 8-BIT SHIFT REGISTERS WITH SIGN EXTEND

electrical characteristics over recommended operating free-air temperature range (unless otherwise noted)

PARAMETER	TEST CONDITIONS†	SN54LS322A		SN74LS322A		UNIT			
		MIN	TYP‡	MAX	MIN		TYP‡	MAX	
V _{IK}	V _{CC} = MIN, I _I = -18 mA			-1.5		V			
V _{OH}	Q _A thru Q _H	V _{CC} = MIN, V _{IH} = 2 V, V _{IL} = MAX,		2.4	3.2	2.4	3.1	V	
	Q _H '	I _{OH} = MAX		2.5	3.4	2.7	3.4		
V _{OL}	Q _A thru Q _H	V _{CC} = MIN, V _{IH} = 2 V, V _{IL} = MAX	I _{OL} = 12 mA	0.25	0.4	0.25	0.4	V	
			I _{OL} = 24 mA			0.35	0.5		
	Q _H '	I _{OL} = 4 mA	0.25	0.4	0.25	0.4			
		I _{OL} = 8 mA			0.35	0.5			
I _{OZH}	Q _A thru Q _H	V _{CC} = MAX, V _{IH} = 2 V, V _O = 2.7 V			40	40	μA		
I _{OZL}	Q _A thru Q _H	V _{CC} = MAX, V _{IH} = 2 V, V _O = 0.4 V			-0.4	-0.4	mA		
I _I	A thru H	V _{CC} = MAX	V _I = 5.5 V			0.1	0.1	mA	
	Data select		V _I = 7 V			0.2	0.2		
	Sign extend		V _I = 7 V			0.3	0.3		
	Any other		V _I = 7 V			0.1	0.1		
I _{IH}	A thru H, DS	V _{CC} = MAX, V _I = 2.7 V			40	40	μA		
	Sign extend				60	60			
	Any other				20	20			
I _{IL}	Data select	V _{CC} = MAX, V _I = 0.4 V			-0.8	-0.8	mA		
	Sign extend				-1.2	-1.2			
	Any other				-0.4	-0.4			
I _{OS} §	Q _A thru Q _H	V _{CC} = MAX			-30	-130	-30	-130	mA
	Q _H '				-20	-100	-20	-100	
I _{CC}		V _{CC} = MAX	35	60	35	60	mA		

† For conditions shown as MIN or MAX, use the appropriate value specified under recommended operating conditions.

‡ All typical values are at V_{CC} = 5 V, T_A = 25°C.

§ Not more than one output should be shorted at a time and duration of the short-circuit should not exceed one second.

switching characteristics, V_{CC} = 5 V, T_A = 25°C

PARAMETER†	FROM (INPUT)	TO (OUTPUT)	TEST CONDITIONS	MIN	TYP	MAX	UNIT
f _{max}			See Note 2	20	35		MHz
t _{PLH}	CLK	Q _H '	R _L = 2 kΩ, C _L = 15 pF, See Note 2	22		33	ns
t _{PHL}		Q _H '		26		35	
t _{PLH}	CLK	Q _A thru Q _H	R _L = 665 Ω, C _L = 45 pF, See Note 2	16		25	ns
t _{PHL}		Q _A thru Q _H		22		33	
t _{PZH}	G	Q _A thru Q _H	R _L = 665 Ω, C _L = 5 pF, See Note 2	15		35	ns
t _{PZL}		Q _A thru Q _H		15		35	
t _{PHZ}	G	Q _A thru Q _H	R _L = 665 Ω, C _L = 5 pF, See Note 2	15		25	ns
t _{PLZ}		Q _A thru Q _H		15		25	

† f_{max} ≡ maximum clock frequency

t_{PZL} ≡ output enable time to low level

t_{PLH} ≡ propagation delay time, low-to-high-level output

t_{PHZ} ≡ output disable time from high level

t_{PHL} ≡ propagation delay time, high-to-low-level output

t_{PLZ} ≡ output disable time from low level

t_{PZH} ≡ output enable time to high level

NOTE 2: For testing f_{max}, all outputs are loaded simultaneously, each with C_L and R_L as specified for the propagation times. See General Information Section for load circuits and voltage waveforms.

3

TTL DEVICES

TYPES SN54LS323, SN74LS323 8-BIT UNIVERSAL SHIFT/STORAGE REGISTERS

OCTOBER 1976—REVISED APRIL 1985

- Multiplexed Inputs/Outputs Provide Improved Bit Density
- Four Modes of Operation:
Hold (Store) Shift Left
Shift Right Load Data
- Operates with Outputs Enabled or at High Z
- 3-State Outputs Drive Bus Lines Directly
- Can Be Cascaded for N-Bit Word Lengths
- Typical Power Dissipation . . . 175 mW
- Guaranteed Shift (Clock) Frequency . . . 25 MHz
- Applications:
Stacked or Push-Down Registers,
Buffer Storage, and
Accumulator Registers
- SN54LS299 and SN74LS299 Are Similar
But Have Direct Overriding Clear

SN54LS323 . . . J PACKAGE
SN74LS323 . . . DW, J OR N PACKAGE

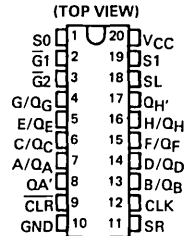

SN54LS323 . . . FK PACKAGE
SN74LS323 . . . FN PACKAGE

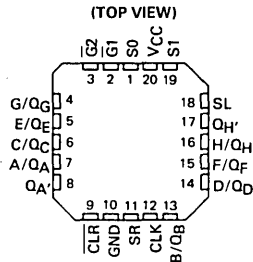

description

These Low-Power Schottky eight-bit universal registers feature multiplexed inputs/outputs to achieve full eight-bit data handling in a single 20-pin package. Two function-select inputs and two output-control inputs can be used to choose the modes of operation listed in the function table. Synchronous parallel loading is accomplished by taking both function-select lines, S0 and S1, high. This places the three-state outputs in a high-impedance state, which permits data that is applied on the input/output lines to be clocked into the register. Reading out of the register can be accomplished while the outputs are enabled in any mode. The clear function is synchronous, and a low level at the clear input clears the register on the next low-to-high transition of the clock.

FUNCTION TABLE

MODE	INPUTS						INPUTS/OUTPUTS								OUTPUTS			
	CLR	FUNCTION SELECT		OUTPUT CONTROL		CLK	SERIAL		A/QA	B/QB	C/QC	D/QD	E/QE	F/QF	G/QG	H/QH	QA'	QH'
		S1	S0	G1†	G2†		SL	SR										
Clear	L	X	L	L	L	†	X	X	L	L	L	L	L	L	L	L	L	L
	L	L	X	L	L	†	X	X	L	L	L	L	L	L	L	L	L	L
Hold	H	L	L	L	L	X	X	X	QA0	QB0	QC0	QD0	QE0	QF0	QG0	QH0	QA0	QH0
	H	X	X	L	L	L	X	X	QA0	QB0	QC0	QD0	QE0	QF0	QG0	QH0	QA0	QH0
Shift Right	H	L	H	L	L	†	X	H	H	QA _n	QB _n	QC _n	QD _n	QE _n	QF _n	QG _n	H	QH _n
	H	L	H	L	L	†	X	L	L	QA _n	QB _n	QC _n	QD _n	QE _n	QF _n	QG _n	L	QH _n
Shift Left	H	H	L	L	L	†	H	X	QB _n	QC _n	QD _n	QE _n	QF _n	QG _n	QH _n	H	QB _n	H
	H	H	L	L	L	†	L	X	QB _n	QC _n	QD _n	QE _n	QF _n	QG _n	QH _n	L	QB _n	L
Load	H	H	H	X	X	†	X	X	a	b	c	d	e	f	g	h	a	h

†When one or both output controls are high the eight input/output terminals are disabled to the high-impedance state; however, sequential operation or clearing of the register is not affected.

a . . . h = the level of the steady-state input at inputs A through H, respectively. These data are loaded into the flip-flops while the flip-flop outputs are isolated from the input/output terminals.

3 TTL DEVICES

PRODUCTION DATA

This document contains information current as of publication date. Products conform to specifications per the terms of Texas Instruments standard warranty. Production processing does not necessarily include testing of all parameters.



POST OFFICE BOX 225012 • DALLAS, TEXAS 75265

TYPES SN54LS323, SN74LS323
8-BIT UNIVERSAL SHIFT/STORAGE REGISTERS

logic diagram

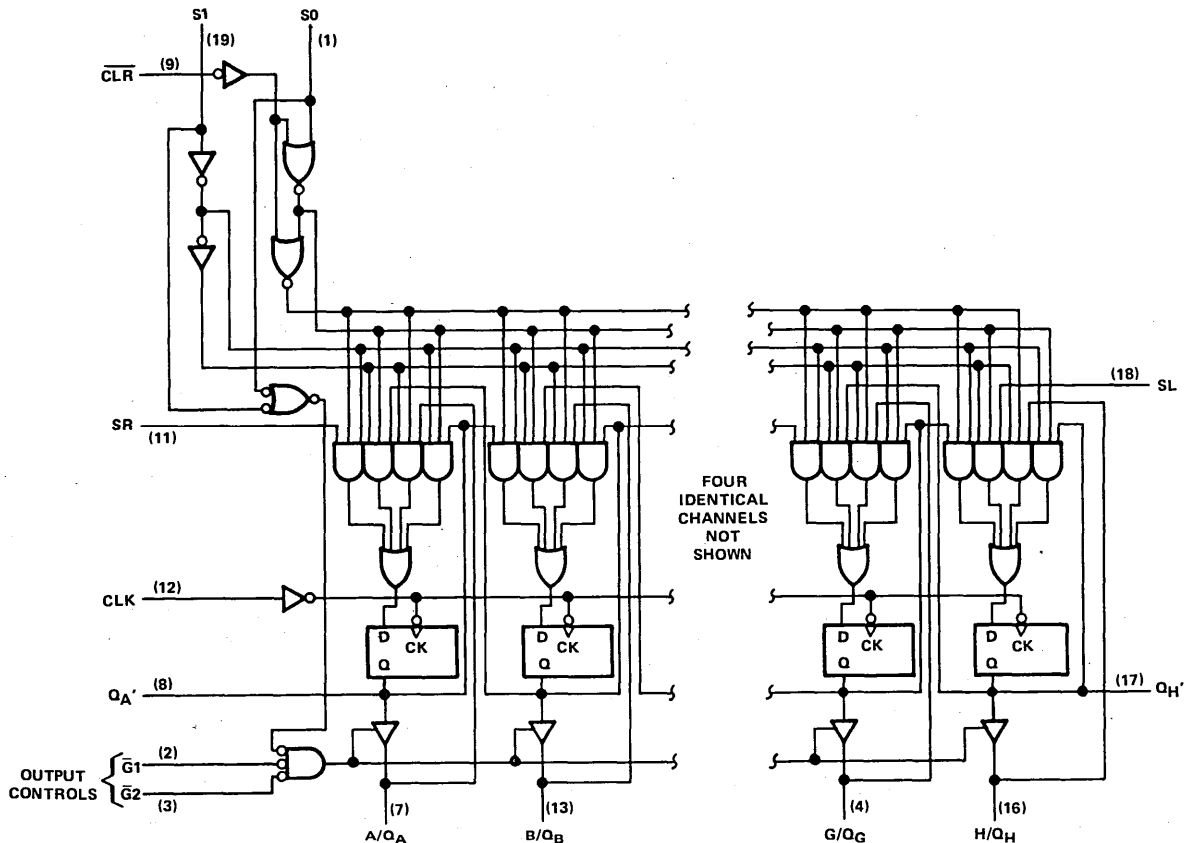

INPUTS/OUTPUTS NOT SHOWN:

- (6) C/QC
- (5) E/QE
- (14) D/QD
- (15) F/QF

Pin numbers shown on logic notation are for DW, J or N packages.

TYPES SN54LS323, SN74LS323
8-BIT UNIVERSAL SHIFT/STORAGE REGISTERS

schematics of inputs and outputs, absolute maximum ratings, recommended operating conditions, and electrical characteristics

Same as SN54LS299 and SN74LS299,

switching characteristics, $V_{CC} = 5\text{ V}$, $T_A = 25^\circ\text{ C}$

PARAMETER [†]	FROM (INPUT)	TO (OUTPUT)	TEST CONDITIONS	MIN	TYP	MAX	UNIT
f_{max}			See Note 1	25	35		MHz
t_{PLH}	CLK	Q_A' or Q_H'	$C_L = 15\text{ pF}$, $R_L = 2\text{ k}\Omega$		22	33	ns
t_{PHL}					26	39	
t_{PLH}	CLK	Q_A thru Q_H	$C_L = 45\text{ pF}$, $R_L = 665\ \Omega$		17	25	ns
t_{PHL}					25	39	
t_{PZH}	\bar{G}_1, \bar{G}_2	Q_A thru Q_H	$C_L = 45\text{ pF}$, $R_L = 665\ \Omega$		14	21	ns
t_{PZL}					20	30	
t_{PHZ}	\bar{G}_1, \bar{G}_2	Q_A thru Q_H	$C_L = 5\text{ pF}$, $R_L = 665\ \Omega$		10	20	ns
t_{PLZ}					10	15	

[†] f_{max} \equiv maximum clock frequency

t_{PLH} \equiv propagation delay time, low-to-high-level output

t_{PHL} \equiv propagation delay time, high-to-low-level output

t_{PZH} \equiv output enable time to high level

t_{PZL} \equiv output enable time to low level

t_{PHZ} \equiv output disable time from high level

t_{PLZ} \equiv output disable time from low level

NOTE 1: For testing f_{max} , all outputs are loaded simultaneously, each with C_L and R_L as specified for the propagation times. See General Information Section for load circuits and voltage waveforms.

3
TTL DEVICES

TYPES SN54LS347, SN74LS347 BCD-TO-SEVEN-SEGMENT DECODERS/DRIVERS

D2426, NOVEMBER 1977—REVISED DECEMBER 1983

- Low-Voltage Version of SN54LS47/SN74LS47
- Open-Collector Outputs Drive Indicators Directly
- Lamp-Test Provision
- Leading/Trailing Zero Suppression
- Lamp Intensity Modulation Capability

SN54LS347 . . . J OR W PACKAGE
SN74LS347 . . . D, J OR N PACKAGE
(TOP VIEW)

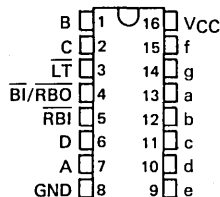

SN54LS347 . . . FK PACKAGE
SN74LS347 . . . FN PACKAGE
(TOP VIEW)

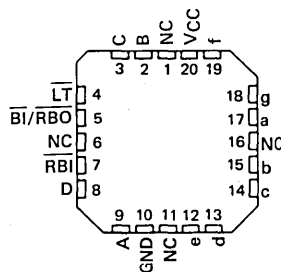

NC - No internal connection

description

The 'LS347 feature active-low outputs designed for driving common-anode VLEDs or incandescent indicators directly. These circuits also have full ripple-blanking input/output controls and a lamp test input. Segment identification and resultant displays are shown on the next page. Display patterns for BCD input counts above 9 are unique symbols to authenticate input conditions.

The 'LS347 incorporate automatic leading and/or trailing-edge zero-blanking control ($\overline{\text{RBI}}$ and $\overline{\text{RBO}}$). Lamp test ($\overline{\text{LT}}$) may be performed at any time when the $\overline{\text{BI/RBO}}$ node is at a high level. These devices also contain an overriding blanking input ($\overline{\text{BI}}$) which can be used to control the lamp intensity by pulsing or to inhibit the outputs. Inputs and outputs are entirely compatible for use with TTL logic outputs.

logic symbol†

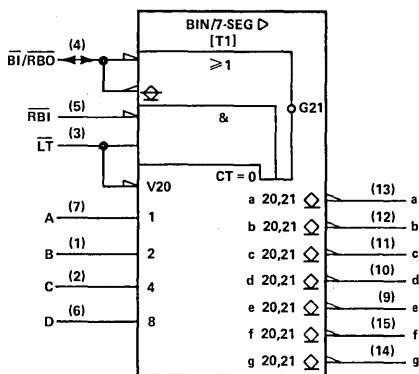

Pin numbers shown on logic notation are for D, J or N packages.

PRODUCTION DATA
This document contains information current as of publication date. Products conform to specifications per the terms of Texas Instruments standard warranty. Production processing does not necessarily include testing of all parameters.

TEXAS
INSTRUMENTS

POST OFFICE BOX 225012 • DALLAS, TEXAS 75265

3-977

3
TTL DEVICES

TYPES SN54LS347, SN74LS347 BCD-TO-SEVEN-SEGMENT DECODERS/DRIVERS

TYPE	DRIVER OUTPUTS				TYPICAL POWER DISSIPATION
	ACTIVE LEVEL	OUTPUT CONFIGURATION	SINK CURRENT	MAX VOLTAGE	
SN54LS347	low	open-collector	12 mA	7 V	35 mW
SN74LS347	low	open-collector	24 mA	7 V	35 mW

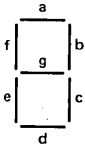

0	1	2	3	4	5	6	7	8	9	10	11	12	13	14	15
---	---	---	---	---	---	---	---	---	---	----	----	----	----	----	----

FONT TABLE T1 - NUMERICAL DESIGNATIONS AND RESULTANT DISPLAYS

SEGMENT IDENTIFICATION

FUNCTION TABLE

DECIMAL OR FUNCTION	INPUTS						$\overline{\text{BI}}/\overline{\text{RBO}}^\dagger$	OUTPUTS							NOTE	
	$\overline{\text{LT}}$	$\overline{\text{RBI}}$	D	C	B	A		a	b	c	d	e	f	g		
0	H	H	L	L	L	L	H	ON	ON	ON	ON	ON	ON	OFF	OFF	1
1	H	X	L	L	L	H	H	OFF	ON	ON	OFF	OFF	OFF	OFF	OFF	
2	H	X	L	L	H	L	H	ON	ON	OFF	ON	ON	OFF	ON		
3	H	X	L	L	H	H	H	ON	ON	ON	ON	OFF	OFF	ON		
4	H	X	L	H	L	L	H	OFF	ON	ON	OFF	OFF	ON	ON		
5	H	X	L	H	L	H	H	ON	OFF	ON	ON	OFF	ON	ON		
6	H	X	L	H	H	L	H	OFF	OFF	ON	ON	ON	ON	ON		
7	H	X	L	H	H	H	H	ON	ON	ON	OFF	OFF	OFF	OFF		
8	H	X	L	L	L	L	H	ON	ON	ON	ON	ON	ON	ON		
9	H	X	H	L	L	H	H	ON	ON	ON	OFF	OFF	ON	ON		
10	H	X	H	L	H	L	H	OFF	OFF	OFF	ON	ON	OFF	ON		
11	H	X	H	L	H	H	H	OFF	OFF	ON	ON	OFF	OFF	ON		
12	H	X	H	H	L	L	H	OFF	ON	OFF	OFF	OFF	ON	ON		
13	H	X	H	H	L	H	H	ON	OFF	OFF	ON	OFF	ON	ON		
14	H	X	H	H	H	L	H	OFF	OF	OFF	ON	ON	ON	ON		
15	H	X	H	H	H	H	H	OFF	OFF	OFF	OFF	OFF	OFF	OFF		
$\overline{\text{BI}}$	X	X	X	X	X	X	L	OFF	OFF	OFF	OFF	OFF	OFF	OFF	2	
$\overline{\text{RBI}}$	H	L	L	L	L	L	L	OFF	OFF	OFF	OFF	OFF	OFF	OFF	3	
$\overline{\text{LT}}$	L	X	X	X	X	X	H	ON	ON	ON	ON	ON	ON	ON	4	

H = high level, L = low level, X = irrelevant

NOTES: 1. The blanking input ($\overline{\text{BI}}$) must be open or held at a high logic level when output functions 0 through 15 are desired. The ripple blanking input ($\overline{\text{RBI}}$) must be open or high if blanking of a decimal zero is not desired.

2. When a low logic level is applied directly to the blanking input ($\overline{\text{BI}}$), all segment outputs are off regardless of the level of any other input.

3. When ripple-blanking input ($\overline{\text{RBI}}$) and inputs A, B, C, and D are at a low level with the lamp test input high, all segment outputs go off and the ripple blanking output ($\overline{\text{RBO}}$) goes to a low level (response condition).

4. When the blanking input/ripple blanking output ($\overline{\text{BI}}/\overline{\text{RBO}}$) is open or held and a low is applied to the lamp test input, all segment outputs are on.

$^\dagger \overline{\text{BI}}/\overline{\text{RBO}}$ is wire AND logic serving as blanking input ($\overline{\text{BI}}$) and/or ripple-blanking output ($\overline{\text{RBO}}$).

3 TTL DEVICES

TYPES SN54LS347, SN74LS347 BCD-TO-SEVEN-SEGMENT DECODERS/DRIVERS

absolute maximum ratings over operating free-air temperature range (unless otherwise noted)

Supply voltage, V_{CC} (see Note 1)	7 V
Input voltage	7 V
Peak output current ($t_w \leq 1$ ms, duty cycle $\leq 10\%$)	200 mA
Current forced into any output in the off-state	1 mA
Operating free-air temperature range: SN54LS347	-55°C to 125°C
SN74LS347	0°C to 70°C
Storage temperature range	-65°C to 150°C

NOTE 1: Voltage values are with respect to network ground terminal.

recommended operating conditions

		SN54LS347			SN74LS347			UNIT
		MIN	NOM	MAX	MIN	NOM	MAX	
V_{CC}	Supply voltage	4.5	5	5.5	4.75	5	5.25	V
V_{IH}	High-level input voltage	2						V
V_{IL}	Low-level input voltage				0.7			V
$V_{O(off)}$	Off-state output voltage	a thru g			7			V
$I_{O(on)}$	On-state output current	a thru g			12			mA
I_{OH}	High-level output current	BI/RBO			-50			μA
I_{OL}	Low-level output current	BI/RBO			1.6			mA
T_A	Operating free-air temperature	-55			125			$^\circ\text{C}$

electrical characteristics over recommended operating free-air temperature range (unless otherwise noted)

PARAMETER	TEST CONDITIONS†	SN54LS347		SN74LS347		UNIT
		MIN	TYP‡	MAX	MIN	
V_{IK}	$V_{CC} = \text{MIN}, I_I = -18 \text{ mA}$	-1.5		-1.5		V
V_{OH}	$V_{CC} = \text{MIN}, V_{IH} = 2 \text{ V}, V_{IL} = \text{MAX}, I_{OH} = -50 \mu\text{A}$	2.4	4.2	2.4	4.2	V
V_{OL}	$V_{CC} = \text{MIN}, V_{IH} = 2 \text{ V}, V_{IL} = \text{MAX}, I_{OL} = 1.6 \text{ mA}$	0.25	0.4	0.25	0.4	V
	$V_{IL} = \text{MAX}, I_{OL} = 3.2 \text{ mA}$			0.35	0.5	
$I_{O(off)}$	$V_{CC} = \text{MAX}, V_{IH} = 2 \text{ V}, V_{O(off)} = 7 \text{ V}, V_{IL} = \text{MAX}$	0.25		0.25		mA
$V_{O(on)}$	$V_{CC} = \text{MAX}, V_{IH} = 2 \text{ V}, V_{IL} = \text{MAX}, I_{O(on)} = 12 \text{ mA}$	0.25	0.4	0.25	0.4	V
	$I_{O(on)} = 24 \text{ mA}$			0.35	0.5	
I_I	$V_{CC} = \text{MAX}, V_I = 7 \text{ V}$	0.1		0.1		mA
I_{IH}	$V_{CC} = \text{MAX}, V_I = 2.7 \text{ V}$	20		20		μA
I_{IL}	Any input except BI/RBO	-0.4		-0.4		mA
	BI/RBO	-1.2		-1.2		
I_{OS}	$V_{CC} = \text{MAX}$	-0.3	-2	-0.3	-2	mA
I_{CC}	$V_{CC} = \text{MAX}$, See Note 2	7	13	7	13	mA

† For conditions shown as MIN or MAX, use the appropriate value specified under recommended operating conditions.

‡ All typical values are at $V_{CC} = 5 \text{ V}, T_A = 25^\circ\text{C}$.

NOTE 2: I_{CC} is measured with all outputs open and all inputs at 4.5 V.

switching characteristics, $V_{CC} = 5 \text{ V}, T_A = 25^\circ\text{C}$

PARAMETER	TEST CONDITIONS	MIN	TYP	MAX	UNIT
t_{off} Turn-off time from A input	$R_L = 665 \Omega, C_L = 15 \text{ pF}$ See Note 3	100			ns
t_{on} Turn-on time from A input		100			
t_{off} Turn-off time from RBI input		100			ns
t_{on} Turn-on time from RBI input		100			

NOTE 3: See General Information Section for load circuits and voltage waveforms, t_{off} corresponds to t_{PLH} and t_{on} corresponds to t_{PHL} .

3
TTL DEVICES

TYPES SN54LS348, SN74LS348 (TIM9908) 8-LINE TO 3-LINE PRIORITY ENCODERS WITH 3-STATE OUTPUTS

OCTOBER 1976—REVISED DECEMBER 1983

- 3-State Outputs Drive Bus Lines Directly
- Encodes 8 Data Lines to 3-Line Binary (Octal)
- Applications Include:
N-Bit Encoding
Code Converters and Generators
- Typical Data Delay . . . 15 ns
- Typical Power Dissipation . . . 60 mW

description

These TTL encoders feature priority decoding of the inputs to ensure that only the highest-order data line is encoded. The 'LS348 circuits encode eight data lines to three-line (4-2-1) binary (octal). Cascading circuitry (enable input E1 and enable output EO) has been provided to allow octal expansion. Outputs A0, A1, and A2 are implemented in three-state logic for easy expansion up to 64 lines without the need for external circuitry. See Typical Application Data.

FUNCTION TABLE

EI	INPUTS								OUTPUTS				
	0	1	2	3	4	5	6	7	A2	A1	A0	GS	EO
H	X	X	X	X	X	X	X	X	Z	Z	Z	H	H
L	H	H	H	H	H	H	H	H	Z	Z	Z	H	L
L	X	X	X	X	X	X	X	L	L	L	L	L	H
L	X	X	X	X	X	X	L	H	L	L	H	L	H
L	X	X	X	X	L	H	H	H	L	H	H	L	H
L	X	X	X	L	H	H	H	H	H	L	L	L	H
L	X	X	L	H	H	H	H	H	H	L	H	L	H
L	X	L	H	H	H	H	H	H	H	H	L	L	H
L	L	H	H	H	H	H	H	H	H	H	H	L	H

H = high logic level, L = low logic level, X = irrelevant
Z = high-impedance state

SN54LS348 . . . J OR W PACKAGE
SN74LS348 . . . D, J OR N PACKAGE
(TOP VIEW)

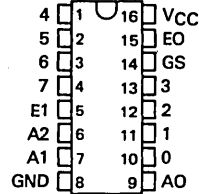

SN54LS348 . . . FK PACKAGE
SN74LS348 . . . FN PACKAGE
(TOP VIEW)

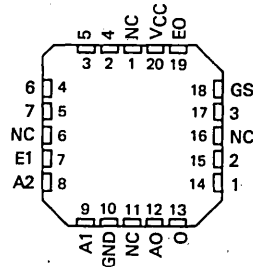

NC — No internal connection

PRODUCTION DATA

This document contains information current as of publication date. Products conform to specifications per the terms of Texas Instruments standard warranty. Production processing does not necessarily include testing of all parameters.

**TEXAS
INSTRUMENTS**

POST OFFICE BOX 225012 • DALLAS, TEXAS 75265

TYPES SN54LS348, SN74LS348 (TIM9908)
8-LINE TO 3-LINE PRIORITY ENCODERS WITH 3-STATE OUTPUTS

logic diagram

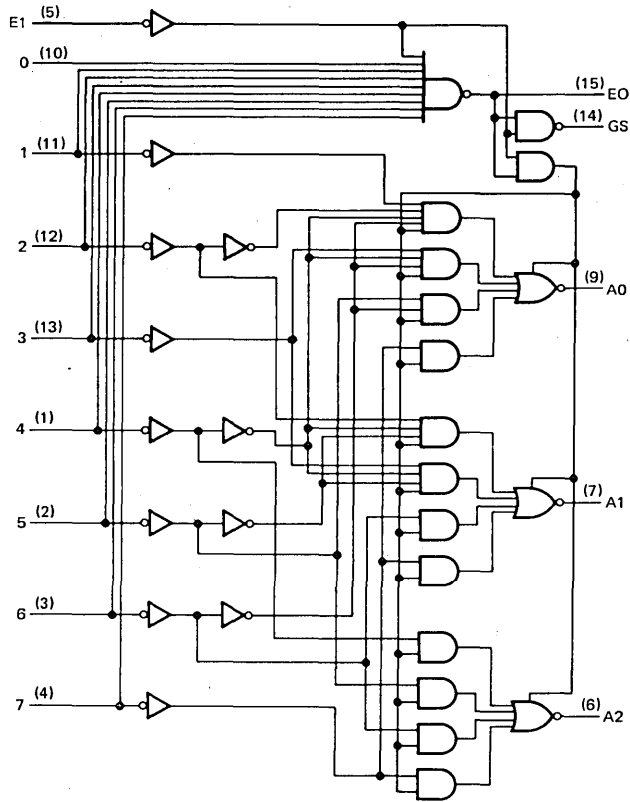

Pin numbers shown on logic notation are for D, J or N packages.

schematic of inputs and outputs

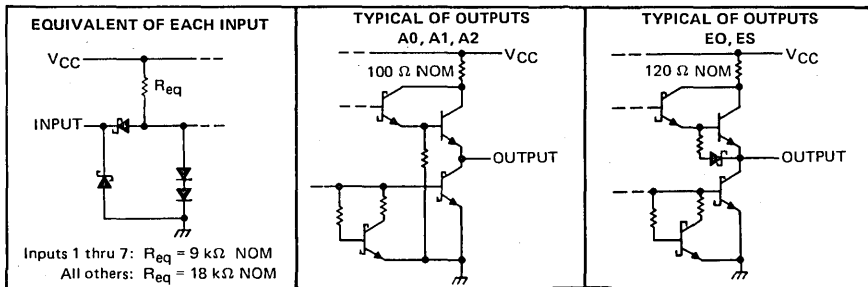

3
TTL DEVICES

TYPES SN54LS348, SN74LS348 (TIM9908)

8-LINE TO 3-LINE PRIORITY ENCODERS WITH 3-STATE OUTPUTS

absolute maximum ratings over operating free-air temperature range (unless otherwise noted)

Supply voltage, V_{CC} (see Note 1)	7 V
Input voltage	7 V
Operating free-air temperature range: SN54LS348	-55°C to 125°C
SN74LS348	0°C to 70°C
Storage temperature range	-65°C to 150°C

NOTE 1: Voltage values are with respect to network ground terminal.

recommended operating conditions

	SN54LS348			SN74LS348			UNIT
	MIN	NOM	MAX	MIN	NOM	MAX	
Supply voltage, V_{CC}	4.5	5	5.5	4.75	5	5.25	V
High-level output current, I_{OH}	A0, A1, A2		-1			-2.6	mA
	EO, GS		-400			-400	μ A
Low-level output current, I_{OL}	A0, A1, A2		12			24	mA
	EO, GS		4			8	mA
Operating free-air temperature, T_A	-55		125	0		70	°C

electrical characteristics over recommended operating free-air temperature range (unless otherwise noted)

PARAMETER		TEST CONDITIONS†	SN54LS348		SN74LS348		UNIT	
			MIN	TYP‡ MAX	MIN	TYP‡ MAX		
V_{IH}	High-level input voltage		2		2		V	
V_{IL}	Low-level input voltage		0.7		0.8		V	
V_{IK}	Input clamp voltage	$V_{CC} = \text{MIN}, I_I = -18 \text{ mA}$	-1.5		-1.5		V	
V_{OH}	High-level output voltage	A0, A1, A2	$V_{CC} = \text{MIN}, I_{OH} = -1 \text{ mA}$	2.4	3.1		V	
		EO, GS	$V_{CC} = 2 \text{ V}, I_{OH} = -2.6 \text{ mA}$			2.4		3.1
V_{OL}	Low-level output voltage	A0, A1, A2	$V_{IL} = V_{ILmax}, I_{OH} = -400 \mu\text{A}$	2.5	3.4	2.7	3.4	V
		EO, GS	$V_{CC} = \text{MIN}, I_{OL} = 12 \text{ mA}$	0.25	0.4	0.25	0.4	
I_{OZ}	Off-State (high-impedance state) output current	A0, A1, A2	$V_{CC} = \text{MAX}, V_{IH} = 2 \text{ V}, V_{OL} = 24 \text{ mA}$			0.35	0.5	μ A
		EO, GS	$V_{IL} = V_{ILmax}, I_{OL} = 4 \text{ mA}$	0.25	0.4	0.25	0.4	
I_I	Input current at maximum input voltage	Inputs 1 thru 7	$V_{CC} = \text{MAX}, V_I = 7 \text{ V}$			20	20	mA
		All other inputs	$V_{CC} = \text{MAX}, V_I = 7 \text{ V}$	0.2		0.2		
I_{IH}	High-level input current	Inputs 1 thru 7	$V_{CC} = \text{MAX}, V_I = 2.7 \text{ V}$			40	40	μ A
		All other inputs	$V_{CC} = \text{MAX}, V_I = 2.7 \text{ V}$	0.1		0.1		
I_{IL}	Low-level input current	Inputs 1 thru 7	$V_{CC} = \text{MAX}, V_I = 0.4 \text{ V}$			-0.8	-0.8	mA
		All other inputs	$V_{CC} = \text{MAX}, V_I = 0.4 \text{ V}$	-0.8		-0.4	-0.4	
I_{OS}	Short-circuit output current§	Outputs A0, A1, A2	$V_{CC} = \text{MAX}, V_O = 2.7 \text{ V}$			-30	-130	mA
		Outputs EO, GS	$V_{CC} = \text{MAX}, V_O = 0.4 \text{ V}$			-20	-100	
I_{CC}	Supply current	Condition 1	$V_{CC} = \text{MAX}$	13	25	13	25	mA
		Condition 2	See Note 2	12	23	12	23	

† For conditions shown as MIN or MAX, use the appropriate value specified under recommended operating conditions.

‡ All typical values are at $V_{CC} = 5 \text{ V}, T_A = 25^\circ \text{C}$.

§ Not more than one output should be shorted at a time.

NOTE 2: I_{CC} (condition 1) is measured with inputs 7 and EI grounded, other inputs and outputs open. I_{CC} (condition 2) is measured with all inputs and outputs open.

3 TTL DEVICES

TYPES SN54LS348, SN74LS348 (TIM9908)

8-LINE TO 3-LINE PRIORITY ENCODERS WITH 3-STATE OUTPUTS

switching characteristics, $V_{CC} = 5\text{ V}$, $T_A = 25^\circ\text{C}$

PARAMETER [†]	FROM (INPUT)	TO (OUTPUT)	WAVEFORM	TEST CONDITIONS	MIN	TYP	MAX	UNIT
t_{PLH}	1 thru 7	A0, A1, or A2	In-phase output	$C_L = 45\text{ pF}$, $R_L = 667\ \Omega$, See Note 3	11	17	ns	
t_{PHL}					20	30		
t_{PLH}	1 thru 7	A0, A1, or A2	Out-of-phase output		23	35	ns	
t_{PHL}					23	35		
t_{PZH}	EI	A0, A1, or A2			25	39	ns	
t_{PZL}					24	41		
t_{PLH}	0 thru 7	EO	Out-of-phase output	$C_L = 15\text{ pF}$, $R_L = 2\text{ k}\Omega$, See Note 3	11	18	ns	
t_{PHL}					26	40		
t_{PLH}	0 thru 7	GS	In-phase output		38	55	ns	
t_{PHL}					9	21		
t_{PLH}	EI	GS	In-phase output		11	17	ns	
t_{PHL}					14	36		
t_{PLH}	EI	EO	In-phase output	17	26	ns		
t_{PHL}				25	40			
t_{PHZ}	EI	A0, A1, or A2		$C_L = 5\text{ pF}$, $R_L = 667\ \Omega$	18	27	ns	
t_{PLZ}					23	35		

- [†] t_{PLH} = propagation delay time, low-to-high-level output
 t_{PHL} = propagation delay time, high-to-low-level output
 t_{PZH} = output enable time to high level
 t_{PZL} = output enable time to low level
 t_{PHZ} = output disable time from high level
 t_{PLZ} = output disable time from low level

NOTE 3: See General Information Section for load circuits and voltage waveforms.

3

TYPICAL APPLICATION DATA

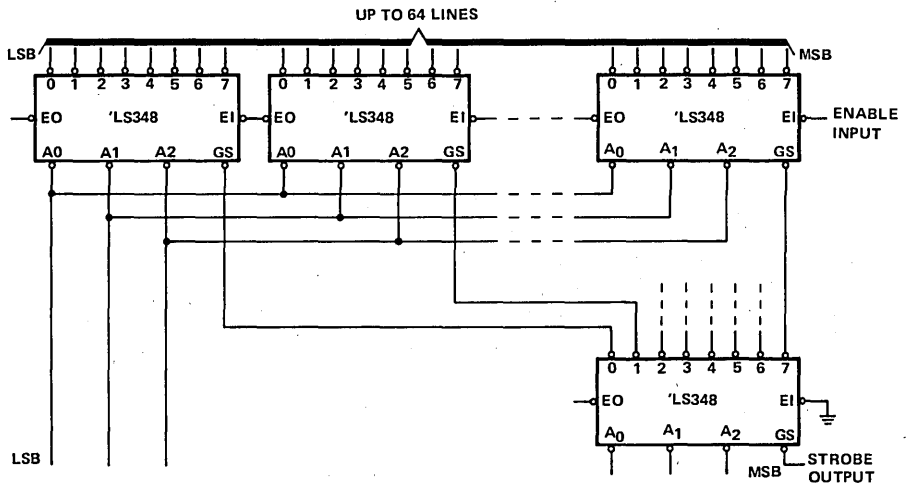

FIGURE 1—PRIORITY ENCODER WITH UP TO 64 INPUTS.

TTL DEVICES

TYPES SN54S350, SN74S350 FOUR-BIT SHIFTER WITH THREE-STATE OUTPUTS

D2745, DECEMBER 1983

- Shifts 4-Bits of Data to 0, 1, 2 or 3 Places Under Control of Two Select Lines
- Three-State Outputs for Bus Organized Systems
- 6.5 ns Typical Data Propagation Delay

description

The 'S350 is operationally equivalent to a 4-input multiplexer with the inputs connected so that the select code causes shifts of the data word. This makes it possible to perform shifts of 0, 1, 2, or 3 places on words of any length, with suitable interconnection.

A 7-bit data word is introduced at the D inputs and is shifted according to the code applied to the select inputs S0 and S1. Y0 through Y3 are 3-state outputs controlled by an output enable, \overline{OE} . When \overline{OE} is low, the outputs follow the selected data inputs; when \overline{OE} is high, the outputs are in a high-impedance state. This feature allows shifters to be cascaded on the same output lines or to a common bus. The shift function can be logical with zeroes pulled in at either or both ends of the shifting field, arithmetic with the sign bit repeated during a shift down, or end-around with the data word forming a continuous loop.

FUNCTION TABLE

INPUTS			OUTPUTS			
\overline{OE}	S1	S0	Y0	Y1	Y2	Y3
H	X	X	Z	Z	Z	Z
L	L	L	D0	D1	D2	D3
L	L	H	D-1	D0	D1	D2
L	H	L	D-2	D-1	D0	D1
L	H	H	D-3	D-2	D-1	D0

SN54S350 ... J PACKAGE
SN74S350 ... D, J OR N PACKAGE
(TOP VIEW)

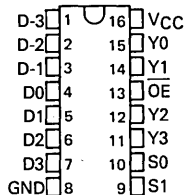

SN54S350 ... FK PACKAGE
SN74S350 ... FN PACKAGE
(TOP VIEW)

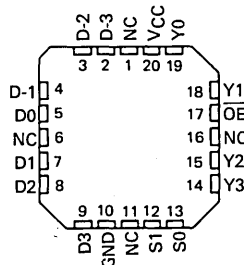

NC - No internal connection

logic equations

$$Y0 = \overline{S0} \overline{S1} D0 + S0 \overline{S1} D-1 + \overline{S0} S1 D-2 + S0 S1 D-3$$

$$Y1 = \overline{S0} \overline{S1} D1 + S0 \overline{S1} D0 + \overline{S0} S1 D-1 + S0 S1 D-2$$

$$Y2 = \overline{S0} \overline{S1} D2 + S0 \overline{S1} D1 + \overline{S0} S1 D0 + S0 S1 D-1$$

$$Y3 = \overline{S0} \overline{S1} D3 + S0 \overline{S1} D2 + \overline{S0} S1 D1 + S0 S1 D0$$

PRODUCTION DATA

This document contains information current as of publication date. Products conform to specifications per the terms of Texas Instruments standard warranty. Production processing does not necessarily include testing of all parameters.

TEXAS
INSTRUMENTS

POST OFFICE BOX 225012 • DALLAS, TEXAS 75265

3-985

TYPES SN54S350, SN74S350 FOUR-BIT SHIFTER WITH THREE-STATE OUTPUTS

logic diagram

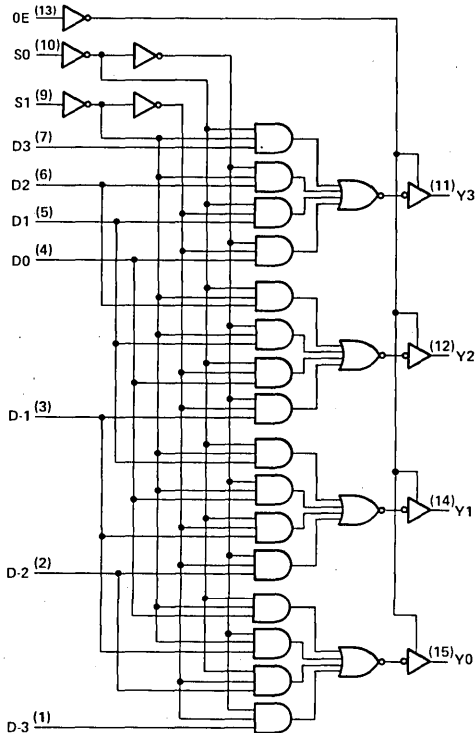

logic symbol

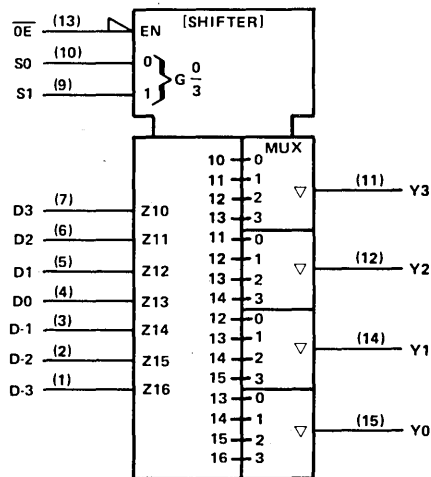

Pin numbers shown on logic notation are for D, J or N packages.

schematics of inputs and outputs

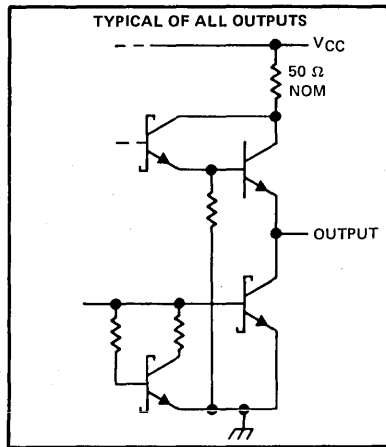
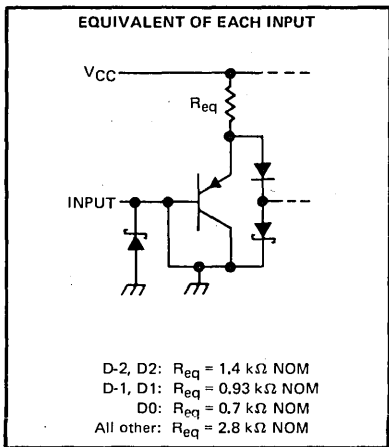

TYPES SN54S350, SN74S350 FOUR-BIT SHIFTER WITH THREE-STATE OUTPUTS

absolute maximum ratings over operating free-air temperature range (unless otherwise noted)

Supply voltage, V_{CC} (see Note 1)	7 V
Input voltage	5.5 V
Voltage applied to a disabled 3-state output	5.5 V
Operating free-air temperature range: SN54S350	-55°C to 125°C
SN74S350	0°C to 70°C
Storage temperature range	-65°C to 150°C

NOTE 1: Voltage values are with respect to network ground terminal.

recommended operating conditions

	SN54S350			SN74S350			UNIT
	MIN	NOM	MAX	MIN	NOM	MAX	
V_{CC} Supply voltage	4.5	5	5.5	4.75	5	5.25	V
V_{IH} High-level input voltage	2			2			V
V_{IL} Low-level input voltage	0.8			0.8			V
I_{OH} High-level output current	-2			-6.5			mA
I_{OL} Low-level output current	20			20			mA
T_A Operating free-air temperature	-55			0			°C

electrical characteristics over recommended operating free-air temperature range (unless otherwise noted)

PARAMETER	TEST CONDITIONS†	SN54S350			SN74S350			UNIT
		MIN	TYP	MAX	MIN	TYP	MAX	
V_{IK}	$V_{CC} = \text{MIN}$, $I_I = -18 \text{ mA}$	-1.2			-1.2			V
V_{OH}	$V_{CC} = \text{MIN}$, $V_{IH} = 2 \text{ V}$, $V_{IL} = 0.8 \text{ V}$, $I_{OH} = \text{MAX}$	2.4	3.4		2.4	3.4		V
V_{OL}	$V_{CC} = \text{MIN}$, $V_{IH} = 2 \text{ V}$, $V_{IL} = 0.8 \text{ V}$, $I_{OL} = 20 \text{ mA}$	0.5			0.5			V
I_{OZH}	$V_{CC} = \text{MAX}$, $V_O = 2.4 \text{ V}$	50			50			μA
I_{OZL}	$V_{CC} = \text{MAX}$, $V_O = 0.5 \text{ V}$	-50			-50			μA
I_I	$V_{CC} = \text{MAX}$, $V_I = 5.5 \text{ V}$	1			1			mA
I_{IH}	D-2, D-1, D-0, D1, D2 inputs	75			75			μA
	All others	50			50			
I_{IL}	D-2, D-1 D-0, D1, D2 inputs	-3			-3			mA
	All others	-2			-2			
$I_{OS}§$	$V_{CC} = \text{MAX}$, $V_O = 0$	-40		-100	-40		-100	mA
I_{CC}	$V_{CC} = \text{MAX}$, $V_I = 0$ All inputs = GND	60 85		60 85				mA

† For conditions shown as MIN or MAX, use the appropriate value specified under recommended operating conditions.

‡ All typical values are at $V_{CC} = 5 \text{ V}$, $T_A = 25^\circ\text{C}$.

§ Not more than one output should be shorted at a time, and duration of the short-circuit should not exceed one second.

3

TTL DEVICES

TYPES SN54S350, SN74S350
FOUR-BIT SHIFTER WITH THREE-STATE OUTPUTS

switching characteristics, $V_{CC} = 5\text{ V}$, $T_A = 25^\circ\text{C}$ (see note 2)

PARAMETER	FROM (INPUT)	TO (OUTPUT)	TEST CONDITIONS	MIN	TYP	MAX	UNIT	
t_{PLH}	Data	Any Y	$R_L = 280\ \Omega$, $C_L = 15\ \text{pF}$			5	9	ns
t_{PHL}						8	12	ns
t_{PLH}	Select	Any Y				11	17	ns
t_{PHL}						13	20	ns
t_{PZH}	\overline{OE}	Any Y					19.5	ns
t_{PZL}							21	ns
t_{PHZ}	\overline{OE}	Any Y	$R_L = 280\ \Omega$, $C_L = 5\ \text{pF}$			8	13	ns
t_{PLZ}						10	15	ns

NOTE 2: See General Information Section for load circuits and voltage waveforms.

3

TTL DEVICES

TYPES SN54S350, SN74S350 FOUR-BIT SHIFTER WITH THREE-STATE OUTPUTS

TYPICAL APPLICATION DATA

16-Bit Shift-Up 0 to 3 Places, Zero Backfill

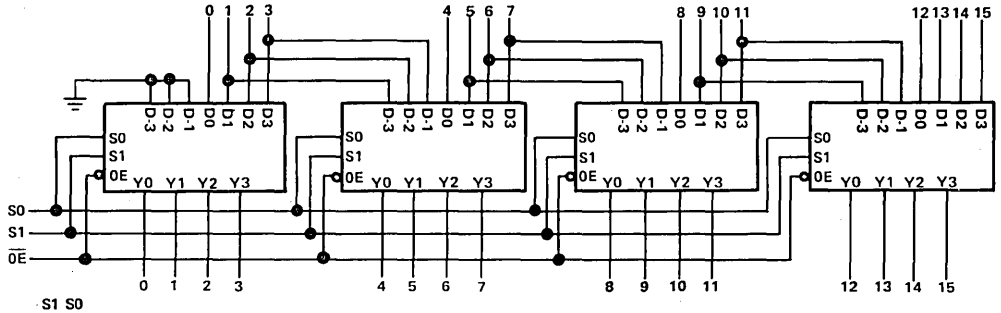

S1 S0

- L L NO SHIFT
- L H SHIFT 1 PLACE
- H L SHIFT 2 PLACES
- H H SHIFT 3 PLACES

8-Bit End-Around Shift 0 to 7 Places

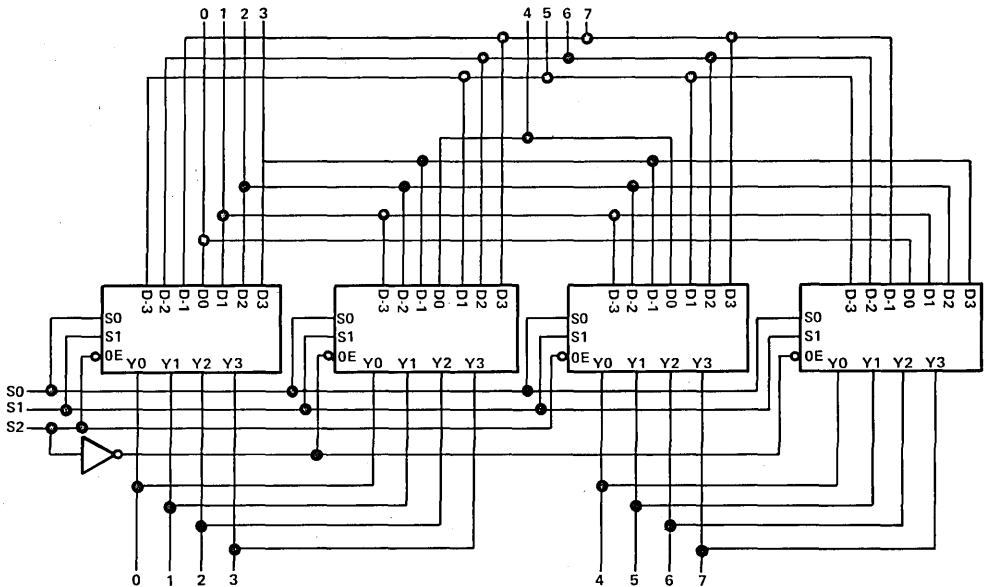

S2 S1 S0

- L L L NO SHIFT
- L L H SHIFT END AROUND 1
- L H L SHIFT END AROUND 2
- L H H SHIFT END AROUND 3
- H L L SHIFT END AROUND 4
- H L H SHIFT END AROUND 5
- H H L SHIFT END AROUND 6
- H H H SHIFT END AROUND 7

3
TTL DEVICES

TYPES SN54S350, SN74S350
FOUR-BIT SHIFTER WITH THREE-STATE OUTPUTS

TYPICAL APPLICATION DATA

13-Bit Twos Complement Scaler

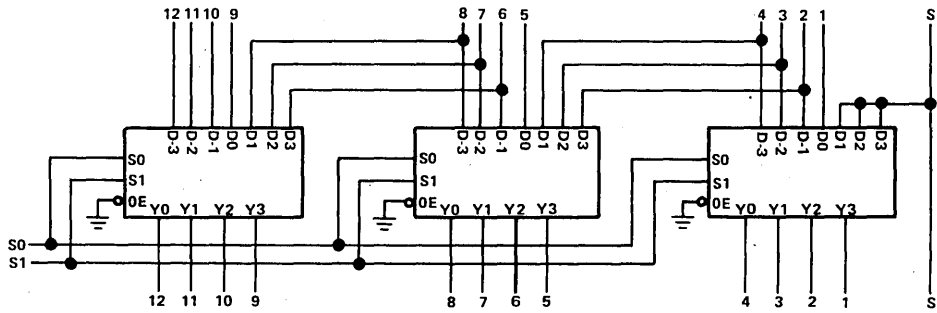

S1 S0	SCALE
L L ÷ 8	1/8
H H ÷ 4	1/4
H L ÷ 2	1/2
H H NO CHANGE	1

TYPE SN74351

DUAL DATA SELECTOR/MULTIPLEXER WITH 3-STATE OUTPUTS

MARCH 1974 — REVISED DECEMBER 1983

- Dual 8-Line-to-1-Line Multiplexer That Can Replace Two SN54151, SN74151 Multiplexers in Some Applications
- Four Common Data Lines Permit Simultaneous Interdigitation with Parallel-to-Serial Conversion
- 4-Bit Organization Is Easily Adapted to Handle Binary or BCD
- Three-State Outputs Can Be Connected Directly to System Bus Lines
- Enable Input Controls Impedance Levels of the 12 Data Inputs and Two Outputs

SN74351 . . . J OR N PACKAGE

(TOP VIEW)

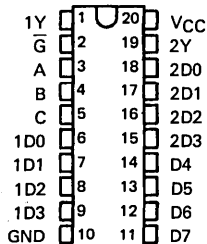

description

The SN74351 comprises two 8-line-to-1-line data selectors/multiplexers with full decoding on one monolithic chip. Symmetrically switching, complementary decode generators minimize decoder skew during changes at the select inputs and ensure that potentially erroneous effects are minimized at the data outputs. Four data inputs are exclusive to each multiplexer and four are common to both. A common enable input is provided which, when high, causes both outputs to assume the high-impedance (off) state and simultaneously diverts the majority of the input current, which reduces the load significantly on the data input drivers. A low logic level at the enable input activates both outputs so that each will assume the complement of the level of the selected input.

FUNCTION TABLE

INPUTS		SELECT		OUTPUTS	
ENABLE	\bar{G}			1Y	2Y
H	X	X	X	Z	Z
L	L	L	L	$\overline{1D0}$	$\overline{2D0}$
L	L	L	H	$\overline{1D1}$	$\overline{2D1}$
L	L	H	L	$\overline{1D2}$	$\overline{2D2}$
L	L	H	H	$\overline{1D3}$	$\overline{2D3}$
L	H	L	L	$\overline{D4}$	$\overline{D4}$
L	H	L	H	$\overline{D5}$	$\overline{D5}$
L	H	H	L	$\overline{D6}$	$\overline{D6}$
L	H	H	H	$\overline{D7}$	$\overline{D7}$

H = high level, L = low level, X = irrelevant
 Z = high impedance (off)
 $\overline{1D0}, \overline{1D1}, \dots, \overline{D7}$ = The complement of the level of the respective D input

PRODUCTION DATA

This document contains information current as of publication date. Products conform to these specifications per the terms of Texas Instruments standard warranty. Production processing does not necessarily include testing of all parameters.



POST OFFICE BOX 225012 • DALLAS, TEXAS 75265

TYPE SN74351 DUAL DATA SELECTOR/MULTIPLEXER WITH 3-STATE OUTPUTS

logic diagram

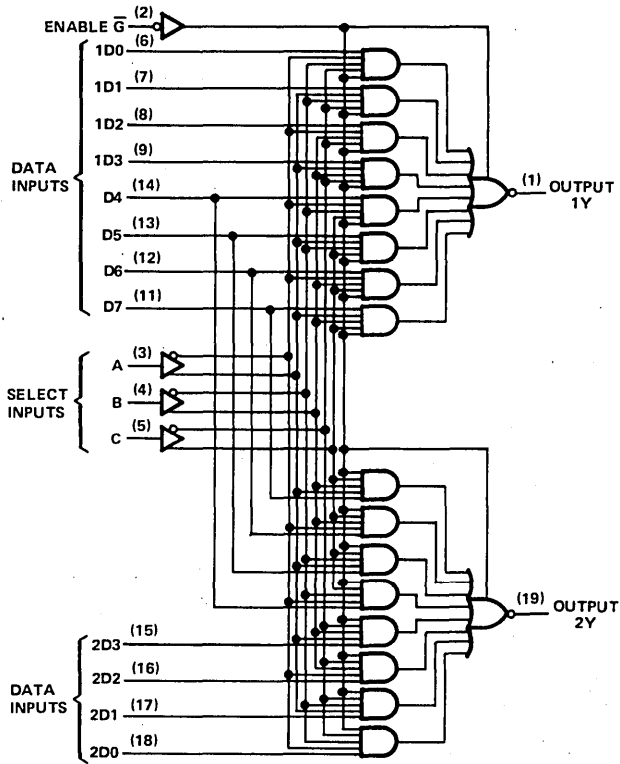

Pin numbers shown on logic notation are for J or N packages.

schematics of inputs and outputs

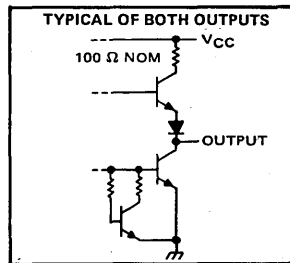
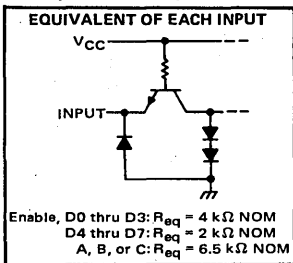

TYPE SN74351

DUAL DATA SELECTOR/MULTIPLEXER WITH 3-STATE OUTPUTS

absolute maximum ratings over operating free-air temperature range (unless otherwise noted)

Supply voltage, V_{CC} (see Note 1)	7 V
Input voltage	5.5 V
Operating free-air temperature range	0°C to 70°C
Storage temperature range	-65°C to 150°C

NOTE 1: Voltage values are with respect to network ground terminal.

recommended operating conditions

	MIN	NOM	MAX	UNIT
V_{CC} Supply voltage	4.75	5	5.25	V
I_{OH} High-level output current			-0.8	mA
I_{OL} Low-level output current			16	mA
T_A Operating free-air temperature	0		70	$^{\circ}\text{C}$

electrical characteristics over recommended operating free-air temperature range (unless otherwise noted)

PARAMETER		TEST CONDITIONS [†]	MIN	TYP [‡]	MAX	UNIT
V_{IH}	High-level input voltage		2			V
V_{IL}	Low-level input voltage				0.8	V
V_{IK}	Input clamp voltage	$V_{CC} = \text{MIN}$, $I_I = -12 \text{ mA}$			-1.5	V
V_{OH}	High-level output voltage	$V_{CC} = \text{MIN}$, $V_{IH} = 2 \text{ V}$, $V_{IL} = 0.8 \text{ V}$, $I_{OH} = -0.8 \text{ mA}$	2.4	3.4		V
V_{OL}	Low-level output voltage	$V_{CC} = \text{MIN}$, $V_{IH} = 2 \text{ V}$, $V_{IL} = 0.8 \text{ V}$, $I_{OL} = 16 \text{ mA}$		0.2	0.4	V
I_{OZH}	Off-state output current, high-level voltage applied	$V_{CC} = \text{MAX}$, $V_{IH} = 2 \text{ V}$, $V_O = 2.4 \text{ V}$			40	μA
I_{OZL}	Off state output current, low level voltage applied	$V_{CC} = \text{MAX}$, $V_{IH} = 2 \text{ V}$, $V_O = 0.4 \text{ V}$			-40	μA
I_I	Input current at maximum input voltage	$V_{CC} = \text{MAX}$, $V_I = 5.5 \text{ V}$			1	mA
I_{IH}	High-level input current	Enable, any select, any D0 thru D3	$V_{CC} = \text{MAX}$, $V_I = 2.4 \text{ V}$		40	μA
		D4 thru D7			80	
I_{IL}	Low-level input current	Enable, any select, any D0 thru D3	$V_{CC} = \text{MAX}$, $V_I = 0.4 \text{ V}$		-1.6	mA
		D4 thru D7			-3.2	
		Any D	$V_{CC} = \text{MAX}$, $V_I = 0.5$, $V_{I(\text{enable})} = 2 \text{ V}$		-40	μA
I_{OS}	Short-circuit output current [§]	$V_{CC} = \text{MAX}$	-18		-55	mA
I_{CC}	Supply current	$V_{CC} = \text{MAX}$, See Note 2		44	66	mA

[†]For conditions shown as MIN or MAX, use the appropriate value specified under recommended operating conditions.

[‡]All typical values are at $V_{CC} = 5 \text{ V}$, $T_A = 25^{\circ}\text{C}$.

[§]Not more than one output should be shorted at a time.

NOTE 2: I_{CC} is measured with the enable input grounded, other inputs and both outputs open.

3

TTL DEVICES

TYPE SN74351 DUAL DATA SELECTOR/MULTIPLEXER WITH 3-STATE OUTPUTS

switching characteristics, $V_{CC} = 5\text{ V}$, $T_A = 25^\circ\text{C}$

PARAMETER [†]	FROM (INPUT)	TO (OUTPUT)	TEST CONDITIONS	MIN	TYP	MAX	UNIT
t_{PLH}	A, B, or C	Y	$C_L = 50\text{ pF}$, $R_L = 400\ \Omega$, See Note 3	20	30	ns	
t_{PHL}				20	30		
t_{PLH}	Any D	Y		10	22	ns	
t_{PHL}				10	22		
t_{PZH}	\bar{G}	Y		18	33	ns	
t_{PZL}				20	33		
t_{PHZ}	\bar{G}	Y	$C_L = 5\text{ pF}$, $R_L = 400\ \Omega$, See Note 3	6	20	ns	
t_{PLZ}			10	20			

NOTE 3: See General Information Section for load circuits and voltage waveforms.

TYPICAL APPLICATION DATA

This application illustrates how common data can be interdigitated onto two serial data lines. It is useful for transmitting prefixes, suffixes, addresses, or similar functions.

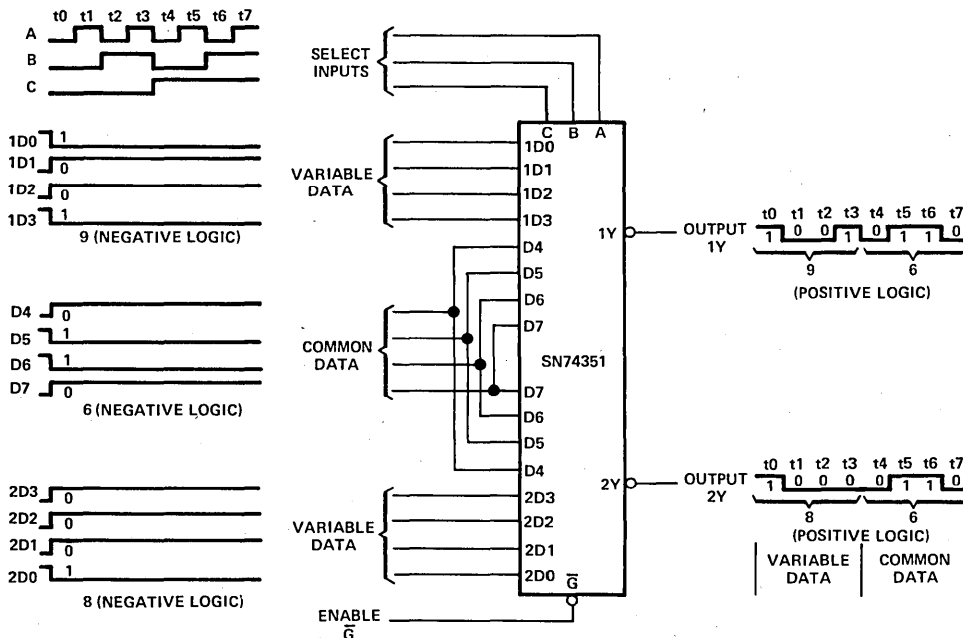

3

TTL DEVICES

TYPES SN54LS352, SN74LS352 DUAL 4-LINE TO 1-LINE DATA SELECTORS/MULTIPLEXERS

OCTOBER 1976 — REVISED DECEMBER 1983

- Inverting Versions of SN54LS153, SN74LS153
- Schottky-Diode-Clamped Transistors
- Permits Multiplexing from N lines to 1 line
- Performs Parallel-to-Serial Conversion
- Typical Average Propagation Delay Times:
Data Input to Output . . . 15 ns
Strobe Input to Output . . . 19 ns
Select Input to Output . . . 22 ns
- Fully Compatible with most TTL Circuits
- Low Power Dissipation . . . 31 mW Typical (Enabled)

description

Each of these Schottky-clamped data selectors/multiplexers contains inverters and drivers to supply fully complementary, on-chip, binary decoding data selection to the AND-OR-invert gates. Separate strobe inputs are provided for each of the two four-line sections.

FUNCTION TABLE

SELECT INPUTS		DATA INPUTS			STROBE	OUTPUT	
B	A	C0	C1	C2	C3	\bar{G}	Y
X	X	X	X	X	X	H	H
L	L	L	X	X	X	L	H
L	L	H	X	X	X	L	L
L	H	X	L	X	X	L	H
L	H	X	H	X	X	L	L
H	L	X	X	L	X	L	H
H	L	X	X	H	X	L	L
H	H	X	X	X	L	L	H
H	H	X	X	X	H	L	L

Select inputs A and B are common to both sections.
H = high level, L = low level, X = irrelevant

absolute maximum ratings over operating free-air temperature range (unless otherwise noted)

Supply voltage, VCC (see Note 1)	7 V
Input voltage	7 V
Operating free-air temperature range: SN54LS352	-55°C to 125°C
SN74LS352	0°C to 70°C
Storage temperature range	-65°C to 150°C

NOTE 1: Voltage values are with respect to network ground terminal.

SN54LS352 . . . J OR W PACKAGE
SN74LS352 . . . D, J OR N PACKAGE
(TOP VIEW)

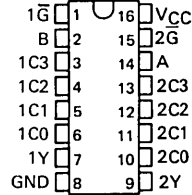

SN54LS352 . . . FK PACKAGE
SN74LS352 . . . FN PACKAGE
(TOP VIEW)

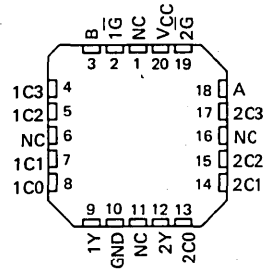

NC — No internal connection

3

TTL DEVICES

PRODUCTION DATA
This document contains information current as of publication date. Products conform to specifications per the terms of Texas Instruments standard warranty. Production processing does not necessarily include testing of all parameters.



POST OFFICE BOX 225012 • DALLAS, TEXAS 75265

TYPES SN54LS352, SN74LS352 DUAL 4-LINE TO 1-LINE DATA SELECTORS/MULTIPLEXERS

logic diagram

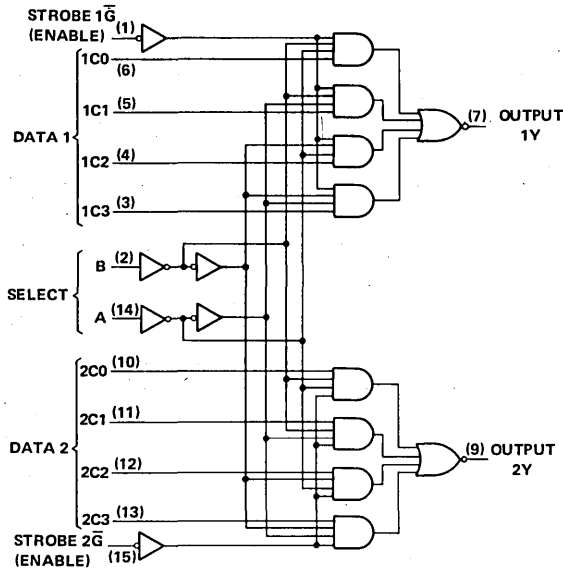

Pin numbers shown on logic notation are for D, J or N packages.

3

TTL DEVICES

schematics of inputs and outputs

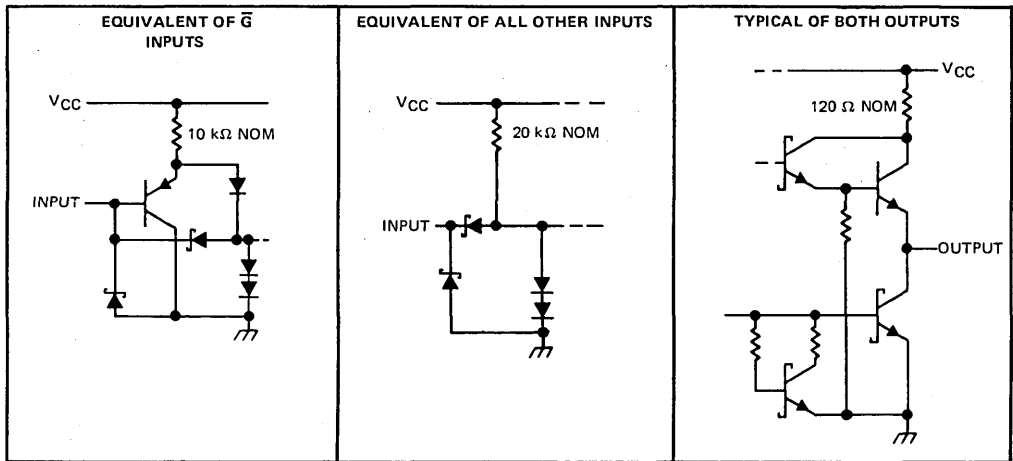

TYPES SN54LS352, SN74LS352 DUAL 4-LINE TO 1-LINE DATA SELECTORS/MULTIPLEXERS

recommended operating conditions

	SN54LS352			SN74LS352			UNIT
	MIN	NOM	MAX	MIN	NOM	MAX	
V _{CC} Supply voltage	4.5	5	5.5	4.75	5	5.25	V
V _{IH} High-level input voltage	2			2			V
V _{IL} Low-level input voltage	0.7			0.8			V
I _{OH} High-level output current	-0.4			-0.4			mA
I _{OL} Low-level output current	4			8			mA
T _A Operating free-air temperature	-55 125			0 70			°C

electrical characteristics over recommended operating free-air temperature range (unless otherwise noted)

PARAMETER	TEST CONDITIONS†	SN54LS352			SN74LS352			UNIT
		MIN	TYP	MAX	MIN	TYP	MAX	
V _{IK}	V _{CC} = MIN, I _I = -18 mA	-1.5			-1.5			V
V _{OH}	V _{CC} = MIN, V _{IH} = 2 V, V _{IL} = MAX, I _{OH} = -0.4 mA	2.5	3.4		2.7	3.4		V
V _{OL}	V _{CC} = MIN, V _{IH} = 2 V, V _{IL} = MAX	I _{OL} = 4 mA		0.25	0.4	0.25	0.4	V
		I _{OL} = 8 mA				0.35	0.5	
I _I	V _{CC} = MAX, V _I = 7 V	0.1			0.1			mA
I _{IH}	V _{CC} = MAX, V _I = 2.7 V	20			20			μA
I _{IL}	\overline{G}	-0.2			-0.2			mA
	All other	-0.4			-0.4			
I _{OS} §	V _{CC} = MAX	-20	-100		-20	-100		mA
I _{CCL}	V _{CC} = MAX, See Note 2	6.2 10			6.2 10			mA

† For conditions shown as MIN or MAX, use the appropriate value specified under recommended operating.

All typical values are at V_{CC} = 5 V, T_A = 25°C.

§ Not more than one output should be shorted at a time, and duration of the short-circuit should not exceed one second.

NOTE 2: I_{CCL} is measured with the outputs open and all inputs grounded.

switching characteristics, V_{CC} = 5 V, T_A = 25°C

PARAMETER‡	FROM (INPUT)	TO (OUTPUT)	TEST CONDITIONS	MIN	TYP	MAX	UNIT
t _{PLH}	Data	Y	R _L = 2 kΩ, See Note 3 C _L = 15 pF,	13	20	ns	
t _{PHL}	Data	Y		17	26	ns	
t _{PLH}	A or B	Y		19	29	ns	
t _{PHL}	A or B	Y		25	38	ns	
t _{PLH}	\overline{G}	Y		16	24	ns	
t _{PHL}	\overline{G}	Y		21	32	ns	

‡ t_{PLH} = propagation delay time, low-to-high-level output

t_{PHL} = propagation delay time, high-to-low-level output

NOTE 3: See General Information Section for load circuits and voltage waveforms.

3
TTL DEVICES

TYPES SN54LS353, SN74LS353 DUAL 4-LINE TO 1-LINE DATA SELECTORS/MULTIPLEXERS WITH 3-STATE OUTPUTS

BULLETIN NO. DL-S 12464, OCTOBER 1976—REVISED DECEMBER 1983

- Inverting Versions of SN54LS253, SN74LS253
- Schottky-Diode-Clamped Transistors
- Permits Multiplexing from N lines to 1 line
- Performs Parallel-to-Serial Conversion
- Typical Average Propagation Delay Times:
Data Input to Output . . . 12 ns
Control Input to Output . . . 16 ns
Select Input to Output . . . 21 ns
- Fully Compatible with most TTL Circuits
- Low Power Dissipation . . . 35 mW Typical (Enabled)
- Inverted Data

SN54LS353 . . . J OR W PACKAGE
SN74LS353 . . . D, J OR N PACKAGE
(TOP VIEW)

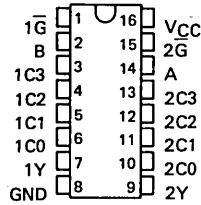

SN54LS353 . . . FK PACKAGE
SN74LS353 . . . FN PACKAGE
(TOP VIEW)

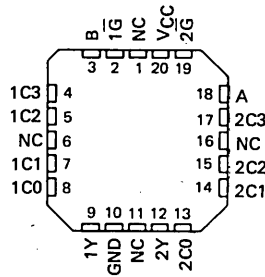

NC - No internal connection

description

Each of these Schottky-clamped data selectors/multiplexers contains inverters and drivers to supply fully complementary, on-chip, binary decoding data selection to the AND-OR-invert gates. Separate output control inputs are provided for each of the two four-line sections.

The three-state outputs can interface with and drive data lines of bus-organized systems. With all but one of the common outputs disabled (at a high-impedance state) the low-impedance of the single enabled output will drive the bus line to a high or low logic level.

logic

FUNCTION TABLE

SELECT INPUTS		DATA INPUTS				OUTPUT CONTROL	OUTPUT
B	A	C0	C1	C2	C3	G	Y
X	X	X	X	X	X	H	Z
L	L	L	X	X	X	L	L
L	L	H	X	X	X	L	L
L	H	X	L	X	X	L	H
L	H	X	H	X	X	L	L
H	L	X	X	L	X	L	H
H	L	X	X	H	X	L	L
H	H	X	X	X	L	L	H
H	H	X	X	X	H	L	L

Select inputs A and B are common to both sections.

H = high level, L = low level, X = irrelevant, Z = high impedance (off)

absolute maximum ratings over operating free-air temperature range (unless otherwise noted)

Supply voltage, V _{CC} (see Note 1)	7 V
Input voltage	7 V
Off-state output voltage	5.5 V
Operating free-air temperature range: SN54LS353	-55°C to 125°C
SN74LS353	0°C to 70°C
Storage temperature range	-65°C to 150°C

NOTE 1: Voltage values are with respect to network ground terminal.

PRODUCTION DATA
This document contains information current as of publication date. Products conform to specifications per the terms of Texas Instruments standard warranty. Production processing does not necessarily include testing of all parameters.

**TEXAS
INSTRUMENTS**

POST OFFICE BOX 225012 • DALLAS, TEXAS 75265

TYPES SN54LS353, SN74LS353
**DUAL 4-LINE TO 1-LINE DATA SELECTORS/
 MULTIPLEXERS WITH 3-STATE OUTPUTS**

logic diagram

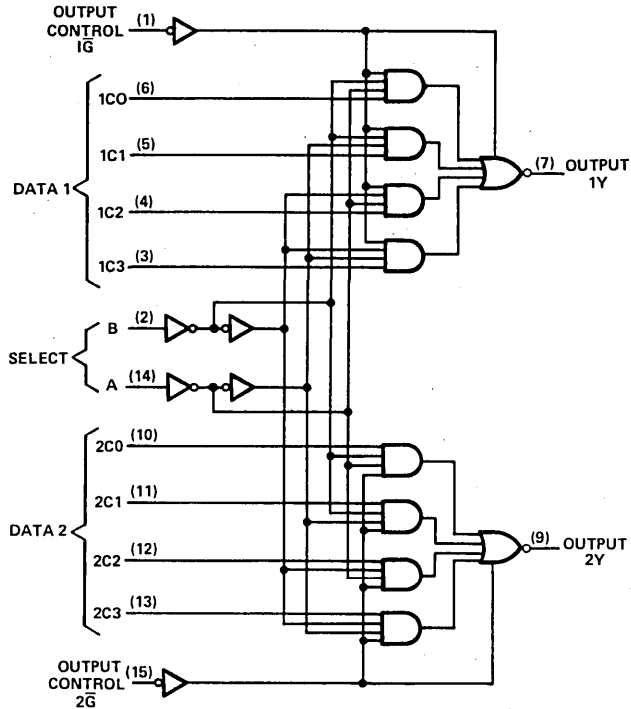

Pin numbers shown on logic notation are for D, J or N packages.

schematic of inputs and outputs

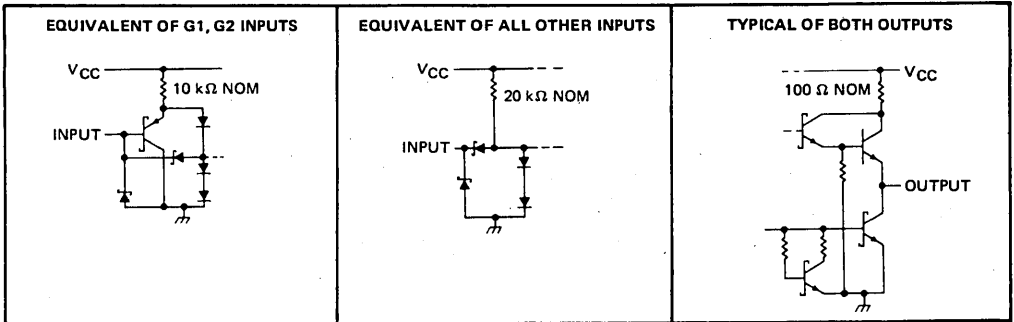

3
TTL DEVICES

TYPES SN54LS353, SN74LS353 DUAL 4-LINE TO 1-LINE DATA SELECTORS/MULTIPLEXERS WITH 3-STATE OUTPUTS

recommended operating conditions

	SN54LS353			SN74LS353			UNIT
	MIN	NOM	MAX	MIN	NOM	MAX	
V _{CC} Supply voltage	4.5	5	5.5	4.75	5	5.25	V
V _{IH} High-level input voltage	2			2			V
V _{IL} Low-level input voltage			0.7			0.8	V
I _{OH} High-level output current			-1			-2.6	mA
I _{OL} Low-level output current			4			8	mA
T _A Operating free-air temperature	-55		125	0		70	°C

electrical characteristics over recommended operating free-air temperature range (unless otherwise noted)

PARAMETER	TEST CONDITIONS †	SN54LS353		SN74LS353		UNIT	
		MIN	TYP ‡	MAX	MIN		TYP ‡
V _{IK}	V _{CC} = MIN, I _I = -18 mA		-1.5		-1.5	V	
V _{OH}	V _{CC} = MIN, V _{IH} = 2 V, V _{IL} = MAX, I _{OH} = MAX	2.4	3.4	2.4	3.1	V	
V _{OL}	V _{CC} = MIN, V _{IH} = 2 V, V _{IL} = MAX	I _{OL} = 4 mA	0.25	0.4	0.25	0.4	V
		I _{OL} = 8 mA			0.35	0.5	
I _{OZ}	V _{CC} = MAX, V _{IH} = 2 V		20		20	μA	
I _I	V _{CC} = MAX, V _I = 7 V	V _O = 2.7 V	-20		-20	mA	
		V _O = 0.4 V					
I _{IH}	V _{CC} = MAX, V _I = 2.7 V		20		20	μA	
I _{IL}	G1, G1	V _{CC} = MAX, V _I = 0.4 V		-0.2		-0.2	mA
	All other			-0.4		-0.4	
I _{OS} §	V _{CC} = MAX		-30	-130	-30	-130	mA
I _{CC}	V _{CC} = MAX, See Note 2	Condition A	7	12	7	12	mA
		Condition B	8.5	14	8.5	14	

† For conditions shown as MIN or MAX, use the appropriate value specified under recommended operating conditions.

‡ All typical values are at V_{CC} = 5 V, T_A = 25°C.

§ Not more than one output should be shorted at a time, and duration of the short-circuit should not exceed one second.

NOTE 2: I_{CC} is measured with the outputs open under the following conditions:

A. All inputs grounded.

B. Output control at 4.5 V, all inputs grounded.

switching characteristics, V_{CC} = 5 V, T_A = 25°C

PARAMETER ¶	FROM (INPUT)	TO (OUTPUT)	TEST CONDITIONS		MIN	TYP	MAX	UNIT
t _{PLH}	Data	Y	C _L = 15 pF, R _L = 2 kΩ, See Note 3		11	25	ns	
t _{PHL}					13	20		
t _{PLH}	Select	Y			20	45	ns	
t _{PHL}					21	32		
t _{pZH}	Output Control	Y			11	23	ns	
t _{pZL}					15	23		
t _{PHZ}	Output Control	Y	C _L = 5 pF, R _L = 2 kΩ, See Note 3		27	41	ns	
t _{PLZ}			12		27			

¶ t_{PLH} = Propagation delay time, low-to-high-level output

t_{PHL} = Propagation delay time, high-to-low-level output

t_{pZH} = Output enable time to high level

t_{pZL} = Output enable time to low level

t_{PHZ} = Output disable time from high level

t_{PLZ} = Output disable time from low level

NOTE 3: See General Information Section for load circuits and voltage waveforms.

3

TTL DEVICES

TYPES SN54LS354, SN54LS355, SN54LS356, SN54LS357, SN74LS354, SN74LS355, SN74LS356, SN74LS357 8-LINE TO 1-LINE DATA SELECTORS/MULTIPLEXERS/REGISTERS

D2544, JULY 1979—REVISED APRIL 1985

- **Transparent Latches on Data Select Inputs**
- **Choice of Data Registers:**
Transparent ('LS354, 'LS355)
Edge-Triggered ('LS356, 'LS357)
- **Choice of Outputs:**
Three-State ('LS354, 'LS356)
Open-Collector ('LS355, 'LS357)
- **Complementary Outputs**
- **Easily Expandable**
- **High-Density 20-Pin Package**

description

These monolithic data selectors/multiplexers contain full on-chip binary decoding to select one of eight data sources. The data-select address is stored in transparent latches that are enabled by a low level on pin 11, SC. On the 'LS354 and 'LS355 a similar enable for data is obtained by a low level on pin 9, DC. The edge-triggered data registers of the 'LS356 and 'LS357 are clocked by a low-to-high transition on pin 9, CLK. Complementary outputs are available in either three-state versions ('LS354 and 'LS356) or open-collector versions ('LS355 and 'LS357).

The SN54LS354 through SN54LS357 are characterized for operation over the full military temperature range of -55° to 125°C ; the SN74LS354 through SN74LS357 are characterized for operation from 0°C to 70°C .

SN54LS354, SN54LS355 . . . J PACKAGE
SN74LS354, SN74LS355 . . . DW, J OR N PACKAGE
(TOP VIEW)

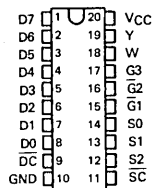

SN54LS354, SN54LS355 . . . FK PACKAGE
SN74LS354, SN74LS355 . . . FN PACKAGE
(TOP VIEW)

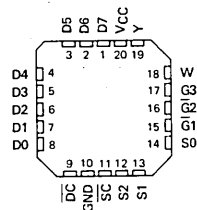

SN54LS356, SN54LS357 . . . J PACKAGE
SN74LS357, SN74LS357 . . . DW, J OR N PACKAGE
(TOP VIEW)

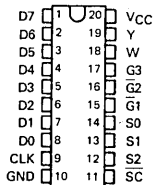

SN54LS356, SN54LS357 . . . FK PACKAGE
SN74LS356, SN74LS357 . . . FN PACKAGE
(TOP VIEW)

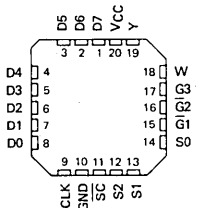

PRODUCTION DATA
This document contains information current as of publication date. Products conform to specifications per the terms of Texas Instruments standard warranty. Production processing does not necessarily include testing of all parameters.

TEXAS
INSTRUMENTS

POST OFFICE BOX 225012 • DALLAS, TEXAS 75265

3-1001



TTL DEVICES

**TYPES SN54LS354, SN54LS355, SN54LS356, SN54LS357,
SN74LS354, SN74LS355, SN74LS356, SN74LS357
8-LINE TO 1-LINE DATA SELECTORS/MULTIPLEXERS/REGISTERS**

FUNCTION TABLE

SELECT			INPUTS		OUTPUT ENABLES			OUTPUTS	
S2	S1	S0	DATA CONTROL ('LS354, 'LS355)	CLOCK ('LS356, 'LS357)	G1	G2	G3	W	Y
X	X	X	X	X	H	X	X	Z	Z
X	X	X	X	X	X	H	X	Z	Z
X	X	X	X	X	X	X	L	Z	Z
L	L	L	L	L	L	L	H	$\bar{D}0$	$\bar{D}0$
L	L	L	L	H	Hor	L	H	$\bar{D}0_n$	$\bar{D}0_n$
L	L	H	L	L	L	L	H	$\bar{D}1$	D1
L	L	H	H	Hor	L	L	H	$\bar{D}1_n$	D1_n
L	H	L	L	L	L	L	H	$\bar{D}2$	D2
L	H	L	H	Hor	L	L	H	$\bar{D}2_n$	D2_n
L	H	H	L	L	L	L	H	$\bar{D}3$	D3
L	H	H	H	Hor	L	L	H	$\bar{D}3_n$	D3_n
H	L	L	L	L	L	L	H	$\bar{D}4$	D4
H	L	L	H	Hor	L	L	H	$\bar{D}4_n$	D4_n
H	L	H	L	L	L	L	H	$\bar{D}5$	D5
H	L	H	H	Hor	L	L	H	$\bar{D}5_n$	D5_n
H	H	L	L	L	L	L	H	$\bar{D}6$	D6
H	H	L	H	Hor	L	L	H	$\bar{D}6_n$	D6_n
H	H	H	L	L	L	L	H	$\bar{D}7$	D7
H	H	H	H	Hor	L	LL	H	$\bar{D}7_n$	D7_n

H = high level (steady state)
L = low level (steady state)
X = irrelevant (any input, including transitions)
Z = high-impedance state (off state)
... = transition from low to high level
D0...D7 = the level of steady-state inputs at inputs D0 through D7, respectively, at the time of the low-to-high clock transition in the case of 'LS356 and 'LS357
D0_n...D7_n = the level of steady state inputs at inputs D0 through D7, respectively, before the most recent low-to-high transition of data control or clock
This column shows the input address setup with $\bar{S}C$ low.

TYPICAL OF BOTH OUTPUTS ON 'LS355 AND 'LS357

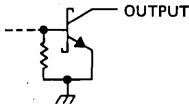

schematics of inputs and outputs

EQUIVALENT OF EACH DATA OR SELECT INPUT

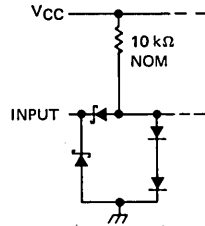

EQUIVALENT OF ALL OTHER INPUTS

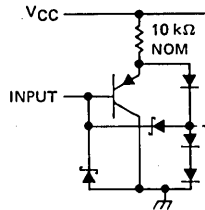

TYPICAL OF BOTH OUTPUTS ON 'LS354 AND 'LS356

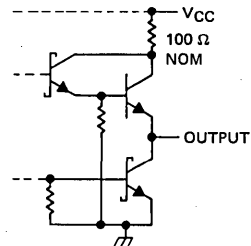

absolute maximum ratings over operating free-air temperature range (unless otherwise noted)

Supply voltage (see Note 1)	7 V
Input voltage	7 V
Operating free-air temperature range: SN54LS'	-55° C to 125° C
SN74LS'	0° C to 70° C
Storage temperature range	-65° C to 150° C

NOTE 1: Voltage values are with respect to network ground terminal.

3

TTL DEVICES

TYPES SN54LS354, SN54LS355, SN54LS356, SN54LS357,
 SN74LS354, SN74LS355, SN74LS356, SN74LS357
 8-LINE TO 1-LINE DATA SELECTORS/MULTIPLEXERS/REGISTERS

logic symbols

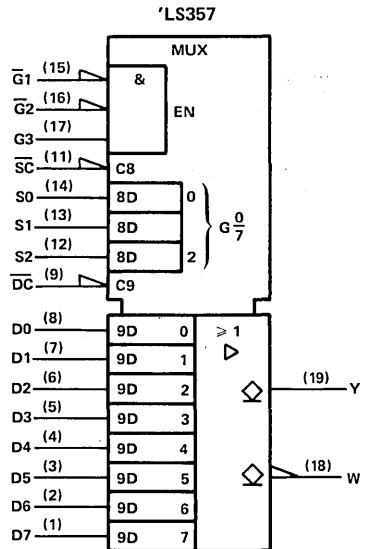
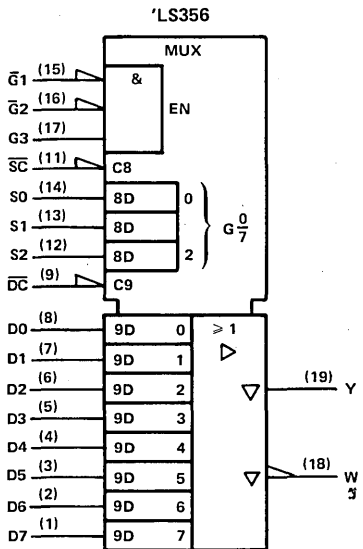
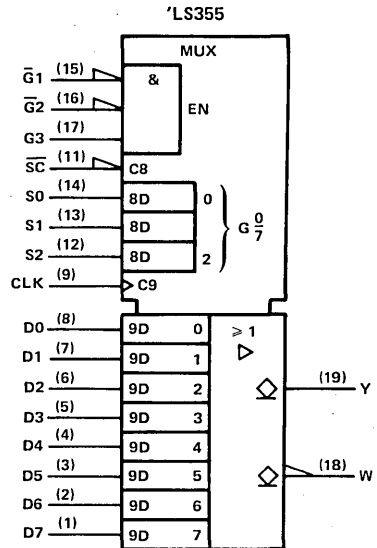
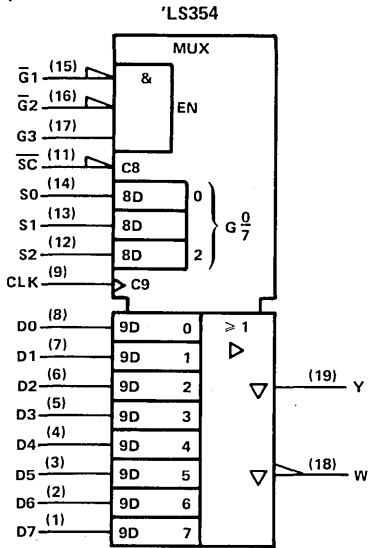

Pin numbers shown on logic notation are for DW, J or N packages.

TYPES SN54LS354, SN54LS355, SN74LS354, SN74LS355
8-LINE TO 1-LINE DATA SELECTORS/MULTIPLEXERS/REGISTERS

logic diagram (positive logic)

'LS354, 'LS355

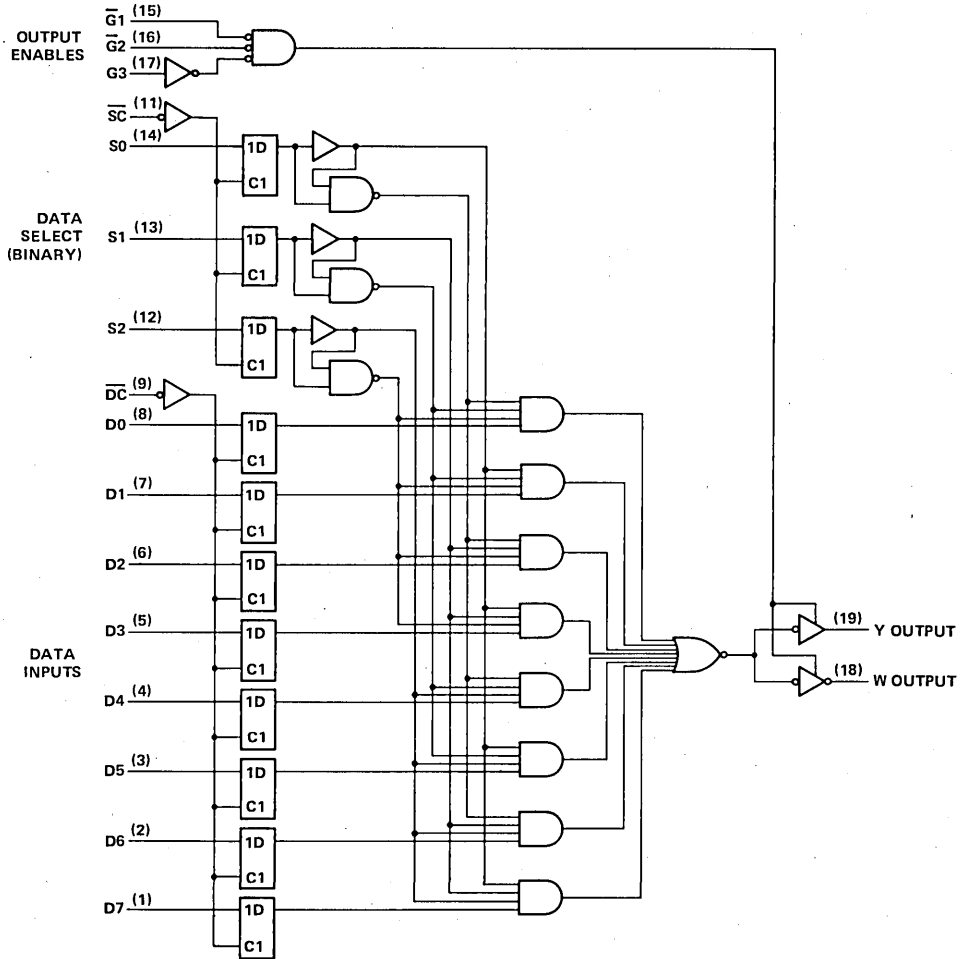

Pin numbers shown on logic notation are for DW, J or N packages.

TYPES SN54LS356, SN54LS357, SN74LS356, SN74LS357
 8-LINE TO 1-LINE DATA SELECTORS/MULTIPLEXERS/REGISTERS

logic diagram (positive logic)

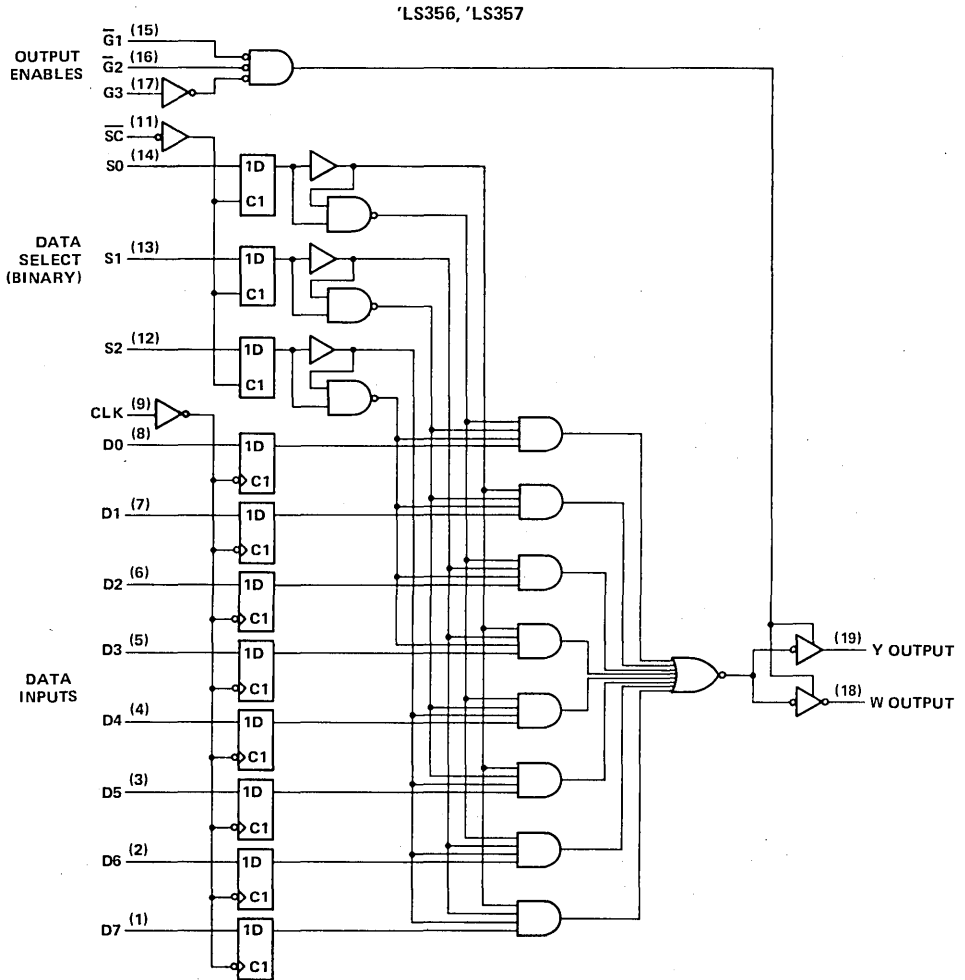

Pin numbers shown on logic notation are for DW, J or N packages.

TTL DEVICES

TYPES SN54LS354, SN54LS356, SN74LS354, SN74LS356
8-LINE TO 1-LINE DATA SELECTORS/MULTIPLEXERS/REGISTERS
WITH 3-STATE OUTPUTS

recommended operating conditions

	SN54LS354 SN54LS356			SN74LS354 SN74LS356			UNIT
	MIN	NOM	MAX	MIN	NOM	MAX	
V _{CC} Supply voltage	4.5	5	5.5	4.75	5	5.25	V
V _{IH} High-level input voltage	2			2			V
V _{IL} Low-level input voltage			0.7			0.8	V
I _{OH} High-level output current			-1			-2.6	mA
I _{OL} Low-level output current			12			24	mA
t _{su} Setup times, high-or-low-level data (with respect to † at pin 9)	'LS354	15		15			ns
	'LS356	15		15			
t _h Hold times, high-or-low-level data (with respect to † at pin 9)	'LS354	15		15			ns
	'LS356	0		0			
T _A Operating free-air temperature	-55		125	0		70	°C

electrical characteristics over recommended operating free-air temperature range (unless otherwise noted)

PARAMETER	TEST CONDITIONS†	SN54LS354 SN54LS356		SN74LS354 SN74LS356		UNIT	
		MIN	TYP‡	MAX	MIN		TYP‡
V _{IK}	V _{CC} = MIN, I _I = -18 mA			-1.5		-1.5	V
V _{OH}	V _{CC} = MIN, V _{IH} = 2 V, V _{IL} = MAX, I _{OH} = MAX,	2.4			2.4		V
V _{OL}	V _{CC} = MIN, V _{IH} = 2 V, V _{IL} = MAX	I _{OL} = 12 mA	0.25	0.4	0.25	0.4	V
		I _{OL} = 24 mA			0.35	0.5	
I _{OZ}	V _{CC} = MAX, V _O = 2.7 V, V _O = 0.4 V		20			20	μA
I _I	V _{CC} = MAX, V _I = 7 V		0.1			0.1	mA
I _{IH}	V _{CC} = MAX, V _I = 2.7 V		20			20	μA
I _{IL}	DC or CLK, G ₁ , G ₂ , G ₃	V _{CC} = MAX, V _I = 0.4 V		-0.2		-0.2	mA
	All others			-0.4		-0.4	
I _{OS} §	V _{CC} = MAX	-30		-130	-30		mA
I _{CC}	V _{CC} = MAX, See Note 2	29	46		29	46	mA

† For conditions shown as MIN or MAX, use the appropriate values specified under recommended operating conditions.
 ‡ All typical values are at V_{CC} = 5 V, T_A = 25° C.
 § Not more than one output should be shorted at a time, and duration of the short-circuit should not exceed one second.
 NOTE 2: I_{CC} is measured with the inputs grounded and the outputs open.

3
TTL DEVICES

TYPES SN54LS354, SN54LS356, SN74LS354, SN74LS356
8-LINE TO 1-LINE DATA SELECTORS/MULTIPLEXERS/REGISTERS
WITH 3-STATE OUTPUTS

switching characteristics, $V_{CC} = 5\text{ V}$, $T_A = 25^\circ\text{C}$, $R_L = 667\ \Omega$

PARAMETER	FROM (INPUT)	TO (OUTPUT)	TEST CONDITIONS	'LS354			'LS356			UNIT
				MIN	TYP	MAX	MIN	TYP	MAX	
t _{PLH}	D0-D7	Y	$C_L = 45\text{ pF}$, See Note 3	24	36				ns	
t _{PHL}				23	35					
t _{PLH}		W		18	27			ns		
t _{PHL}				29	44					
t _{PLH}	\overline{DC} or CLK	Y		28	42	18	27	ns		
t _{PHL}				26	39	33	50			
t _{PLH}		W		22	33	24	36	ns		
t _{PHL}				33	50	18	27			
t _{PLH}	S0, S1 S2	Y		29	44	30	45	ns		
t _{PHL}				24	45	28	48			
t _{PLH}		W		28	42	36	54	ns		
t _{PHL}				34	51	30	45			
t _{PLH}	\overline{SC}	Y	34	51	36	54	ns			
t _{PHL}			31	47	40	60				
t _{PLH}		W	27	41	32	48	ns			
t _{PHL}			40	60	36	54				
t _{PZH}	$\overline{G1}, \overline{G2}$	Y	$C_L = 5\text{ pF}$, See Note 3	14	27	14	25	ns		
t _{PZL}				18	27	17	25			
t _{PHZ}				15	25	16	24			
t _{PLZ}				15	25	16	24			
t _{PZH}		W		$C_L = 45\text{ pF}$, See Note 3	12	24	14	23	ns	
t _{PZL}					16	24	16	23		
t _{PHZ}					$C_L = 5\text{ pF}$, See Note 3	15	25	16		23
t _{PLZ}						15	25	16		23
t _{PZH}	Y	$C_L = 45\text{ pF}$, See Note 3	15			29	15	27	ns	
t _{PZL}			19			29	18	27		
t _{PHZ}			$C_L = 5\text{ pF}$, See Note 3		15	25	16	25		
t _{PLZ}					15	25	16	25		
t _{PZH}	W			$C_L = 45\text{ pF}$, See Note 3	13	25	14	25	ns	
t _{PZL}					17	25	16	25		
t _{PHZ}			$C_L = 5\text{ pF}$, See Note 3		15	25	16	25		
t _{PLZ}					15	25	16	25		

NOTE 3: See General Information Section for load circuits and voltage waveforms.

3
TTL DEVICES

TYPES SN54LS355, SN54LS357, SN74LS355, SN74LS357
8-LINE TO 1-LINE DATA SELECTORS/MULTIPLEXERS/REGISTERS
WITH OPEN-COLLECTOR OUTPUTS

recommended operating conditions

	SN54LS355 SN54LS357			SN74LS355 SN74LS357			UNIT
	MIN	NOM	MAX	MIN	NOM	MAX	
V_{CC} Supply voltage	4.5	5	5.5	4.75	5	5.25	V
V_{IH} High-level input voltage	2			2			V
V_{IL} Low-level input voltage				0.7			V
V_{OH} High-level output voltage				5.5			V
I_{OL} Low-level output current				12			mA
t_{su} Setup times, high-or-low-level data, (with respect to \uparrow at pin 9)	'LS355	15		15			ns
	'LS357	15		15			
t_h Hold times, high-or low-level data (with respect to \uparrow at pin 9)	'LS355	15		15			ns
	'LS357	0		0			
T_A Operating free-air temperature	- 55		125	0		70	°C

electrical characteristics over recommended operating free-air temperature range (unless otherwise noted)

PARAMETER	TEST CONDITIONS†		SN54LS355 SN54LS357		SN74LS355 SN74LS357		UNIT
			MIN	TYP‡	MAX	MIN	
V_{IK}	$V_{CC} = \text{MIN}, I_I = -18 \text{ mA}$		-1.5		-1.5		V
I_{OH}	$V_{CC} = \text{MIN}, V_{IH} = 2 \text{ V}, V_{IL} = \text{MAX}$ $V_{OH} = 5.5 \text{ V}$		0.1		0.1		mA
V_{OL}	$V_{CC} = \text{MIN}, V_{IH} = 2 \text{ V}, V_{IL} = \text{MAX}$	$I_{OL} = 12 \text{ mA}$	0.25	0.4	0.25	0.4	V
		$I_{OL} = 24 \text{ mA}$			0.35	0.5	
I_I	$V_{CC} = \text{MAX}, V_I = 7 \text{ V}$		0.1		0.1		mA
I_{IH}	$V_{CC} = \text{MAX}, V_I = 2.7 \text{ V}$		20		20		μA
I_{IL}	DC or CLK, $\bar{G}_1, \bar{G}_2, G_3$	$V_{CC} = \text{MAX}, V_I = 0.4 \text{ V}$	-0.2		-0.2		mA
	All others		-0.4		-0.4		
I_{CC}	$V_{CC} = \text{MAX},$ See Note 2		29	46	29	46	mA

† For conditions shown as MIN or MAX, use the appropriate value specified under recommended operating conditions for the applicable type.

‡ All typical values are at $V_{CC} = 5 \text{ V}, T_A = 25^\circ\text{C}$.

NOTE 2: I_{CC} is measured with the inputs grounded and the outputs open.

3 TTL DEVICES

TYPES SN54LS355, SN54LS357, SN74LS355, SN74LS357
8-LINE TO 1-LINE DATA SELECTORS/MULTIPLEXERS/REGISTERS
WITH OPEN-COLLECTOR OUTPUTS

switching characteristics, $V_{CC} = 5\text{ V}$, $T_A = 25^\circ\text{C}$, $R_L = 667\ \Omega$

PARAMETER [†]	FROM (INPUT)	TO (OUTPUT)	TEST CONDITIONS	'LS355			'LS357			UNIT
				MIN	TYP	MAX	MIN	TYP	MAX	
t_{PLH}	D0-D7	Y	$C_L = 45\text{ pF}$, See Note 3	34		41				ns
t_{PHL}					26		39			
t_{PLH}		W			30		45			ns
t_{PHL}					33		50			
t_{PLH}	\overline{DC} or CLK	Y			38		57	27	41	ns
t_{PHL}					31		47	34	51	
t_{PLH}		W			33		50	32	48	ns
t_{PHL}					39		59	23	35	
t_{PLH}	S0, S1, S2	Y		39		59	38	57	ns	
t_{PHL}				36		49	40	60		
t_{PLH}		W		32		48	38	57	ns	
t_{PHL}				39		58	35	53		
t_{PLH}	\overline{SC}	Y		45		68	44	66	ns	
t_{PHL}				42		63	41	62		
t_{PLH}		W		44		66	41	62	ns	
t_{PHL}				45		68	41	62		
t_{PHL}	$\overline{G1}, \overline{G2}$	Y		21		32	18	27	ns	
t_{PHL}				22		33	18	27		
t_{PLH}		W		18		27	20	30	ns	
t_{PHL}				19		29	21	32		
t_{PLH}	G3	Y		24		36	24	36	ns	
t_{PHL}				25		40	24	36		
t_{PLH}		W		19		31	19	31	ns	
t_{PHL}				19		29	19	29		

NOTE 3: See General Information Section for load circuits and voltage waveforms.

TTL DEVICES

TYPES SN54365A THRU SN54368A, SN54LS365A THRU SN54LS368A SN74365A THRU SN74368A, SN74LS365A THRU SN74LS368A HEX BUS DRIVERS WITH 3-STATE OUTPUTS

REVISED DECEMBER 1983

- 3-State Outputs Drive Bus Lines or Buffer Memory Address Registers
- Choice of True or Inverting Outputs
- Package Options Include Both Plastic and Ceramic Chip Carriers in Addition to Plastic and Ceramic DIP's
- Dependable Texas Instruments Quality and Reliability

'365A, '367A, 'LS365A, 'LS367A True Outputs
'366A, '368A, 'LS366A, 'LS368A Inverting Outputs

description

These Hex buffers and line drivers are designed specifically to improve both the performance and density of three-state memory address drivers, clock drivers, and bus oriented receivers and transmitters. The designer has a choice of selected combinations of inverting and noninverting outputs, symmetrical \bar{G} (active-low control) inputs.

These devices feature high fan-out, improved fan-in, and can be used to drive terminated lines down to 133 ohms.

The SN54365A thru SN54368A and SN54LS365A thru SN54LS368A are characterized for operation over the full military temperature range of -55°C to 125°C . The SN74365A thru SN74368A and SN74LS365A thru SN74LS368A are characterized for operation from 0°C to 70°C .

SN54365A, 366A, SN54LS365A, 366A ... J PACKAGE
SN74365A, 366A ... J OR N PACKAGE
SN74LS365A, SN74LS366A ... D, J OR N PACKAGE

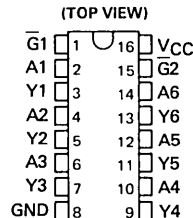

SN54LS365A, SN54LS366A ... FK PACKAGE
SN74LS365A, SN74LS366A ... FN PACKAGE

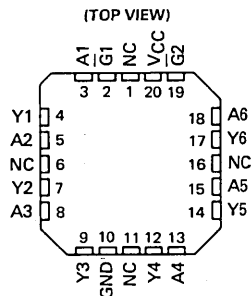

SN54367A, 368A, SN54LS367A, 368A ... J PACKAGE
SN74367A, 368A ... J OR N PACKAGE
SN74LS367A, SN74LS368A ... D, J OR N PACKAGE

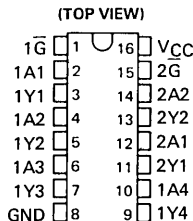

SN54LS367A, SN54LS368A ... FK PACKAGE
SN74LS367A, SN74LS368A ... FN PACKAGE

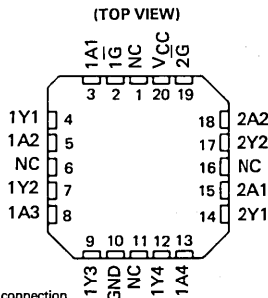

NC - No internal connection

PRODUCTION DATA
This document contains information current as of publication date. Products conform to specifications per the terms of Texas Instruments standard warranty. Production processing does not necessarily include testing of all parameters.

**TEXAS
INSTRUMENTS**

POST OFFICE BOX 225012 • DALLAS, TEXAS 75265

3-1011

3

TTL DEVICES

**TYPES SN54365A THRU SN54368A, SN54LS365A THRU SN54LS368A
SN74365A THRU SN74368A, SN74LS365A THRU SN74LS368A
HEX BUS DRIVERS WITH 3-STATE OUTPUTS**

schematics of inputs and outputs

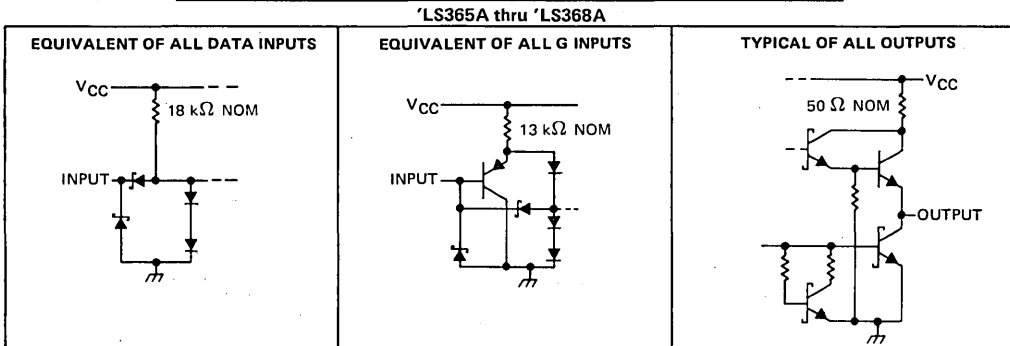
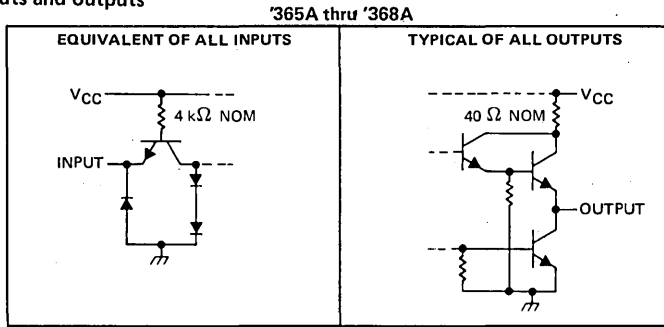

3

TTL DEVICES

logic diagrams (positive logic)

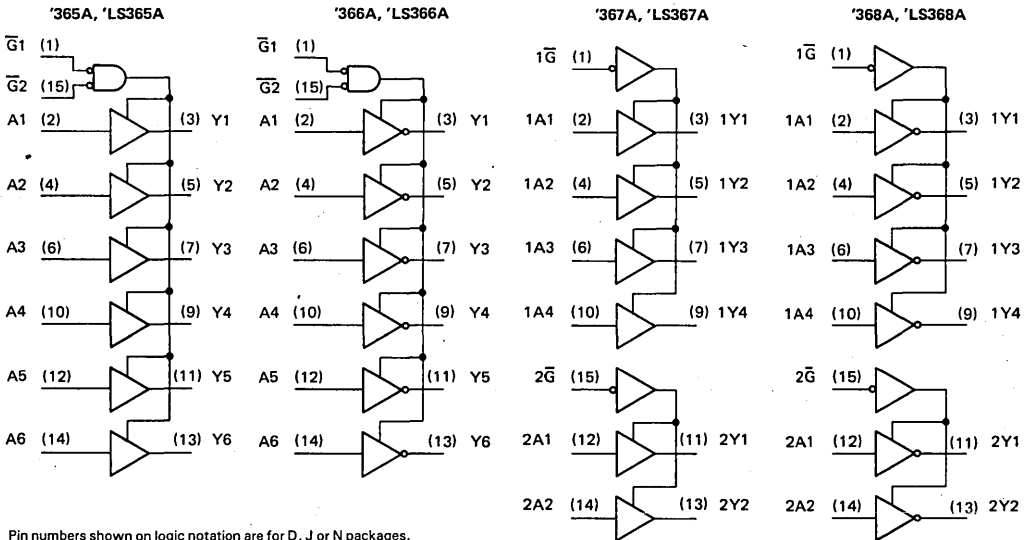

Pin numbers shown on logic notation are for D, J or N packages.

**TYPES SN54365A THRU SN54368A, SN54LS365A THRU SN54LS368A
SN74365A THRU SN74368A, SN74LS365A THRU SN74LS368A
HEX BUS DRIVERS WITH 3-STATE OUTPUTS**

logic symbols

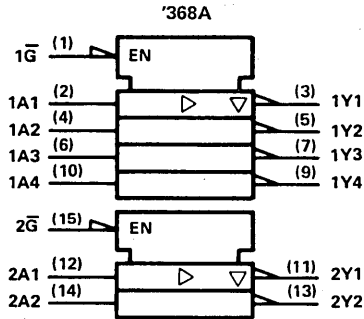
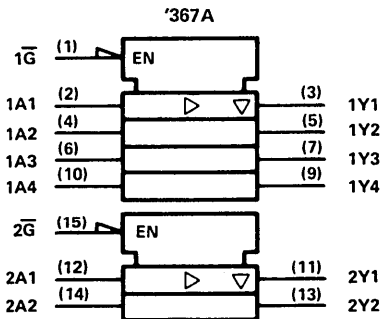
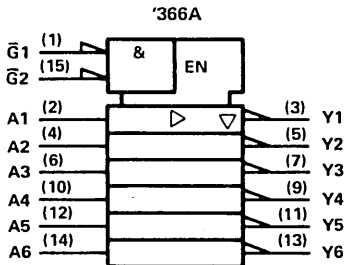
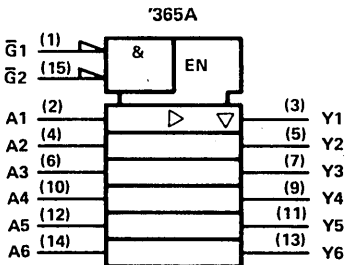

Pin numbers shown on logic notation are for D, J or N packages.

absolute maximum ratings over operating free-air temperature range (unless otherwise noted)

Supply voltage, V_{CC} (see Note 1)	7 V
Input voltage: '365A, '366A, '367A, '368A	5.5 V
'LS365A, 'LS366A, 'LS367A, 'LS368A	7 V
Voltage applied to a disabled 3-state output	5.5 V
Operating free-air temperature: SN54'	-55°C to 125°C
SN74'	0°C to 70°C
Storage temperature range	-65°C to 150°C

NOTE 1: Voltage values are with respect to network ground terminal.

**TYPES SN54365A, SN54367A
SN74365A, SN74367A
HEX BUS DRIVERS WITH 3-STATE OUTPUTS**

recommended operating conditions

	SN54365A SN54367A			SN74365A SN74367A			UNIT
	MIN	NOM	MAX	MIN	NOM	MAX	
V _{CC} Supply voltage	4.5	5	5.5	4.75	5	5.25	V
V _{IH} High-level input voltage	2			2			V
V _{IL} Low-level input voltage			0.8			0.8	V
I _{OH} High-level output current			-2			-5.2	mA
I _{OL} Low-level output current			32			32	mA
T _A Operating free-air temperature	-55		125	0		70	°C

electrical characteristics over recommended operating free-air temperature range (unless otherwise noted)

PARAMETER	TEST CONDITIONS†	SN54365A SN54367A			SN74365A SN74367A			UNIT
		MIN	TYP‡	MAX	MIN	TYP‡	MAX	
V _{IK}	V _{CC} = MIN, I _I = -12 mA			-1.5			-1.5	V
V _{OH}	V _{CC} = MIN, V _{IH} = 2 V, V _{IL} = 0.8 V, I _{OH} = MAX	2.4	3.3		2.4	3.1		V
V _{OL}	V _{CC} = MIN, V _{IH} = 2 V, V _{IL} = 0.8 V, I _{OL} = 32 mA			0.4			0.4	V
I _{OZ}	V _{CC} = MAX, V _{IH} = 2 V, V _{IL} = 0.8 V, V _O = 2.4 V			40			40	μA
	V _{CC} = MAX, V _{IH} = 2 V, V _{IL} = 0.8 V, V _O = 0.4 V			-40			-40	
I _I	V _{CC} = MAX, V _I = 5.5 V			1			1	mA
I _{IH}	V _{CC} = MAX, V _I = 2.4 V			40			40	μA
I _{IL}	A Inputs V _{CC} = MAX, V _I = 0.5 V, Either \bar{G} input at 2 V			-40			-40	μA
	\bar{G} Inputs V _{CC} = MAX, V _I = 0.4 V, Both \bar{G} inputs at 0.4 V			-1.6			-1.6	
I _{OS} §	V _{CC} = MAX			-40			-130	mA
I _{CC}	V _{CC} = MAX, Data inputs = 0 V, Output controls = 4.5 V			65			85	mA

† For conditions shown as MIN or MAX, use the appropriate value specified under recommended operating conditions.

‡ All typical values are at V_{CC} = 5 V, T_A = 25°C.

§ Not more than one output should be shorted at a time.

switching characteristics, V_{CC} = 5 V, T_A = 25°C (see note 2)

PARAMETER	FROM (INPUT)	TO (OUTPUT)	TEST CONDITIONS	MIN	TYP	MAX	UNIT
t _{PLH}	Any	Y	R _L = 400 Ω, C _L = 50 pF			16	ns
t _{PHL}						22	ns
t _{PZH}						35	ns
t _{PZL}						37	ns
t _{PHZ}						11	ns
t _{PLZ}						27	ns

NOTE 2: See General Information Section for load circuits and voltage waveforms.

TYPES SN54366A, SN54368A
SN74366A, SN74368A
HEX BUS DRIVERS WITH 3-STATE OUTPUTS

recommended operating conditions

	SN54366A SN54368A			SN74366A SN74368A			UNIT
	MIN	NOM	MAX	MIN	NOM	MAX	
V _{CC} Supply voltage	4.5	5	5.5	4.75	5	5.25	V
V _{IH} High-level input voltage	2			2			V
V _{IL} Low-level input voltage	0.8			0.8			V
I _{OH} High-level output current	-2			-5.2			mA
I _{OL} Low-level output current	32			32			mA
T _A Operating free-air temperature	-55			0			70 °C

electrical characteristics over recommended operating free-air temperature range (unless otherwise noted)

PARAMETER	TEST CONDITIONS†	SN54366A SN54368A		SN74366A SN74368A		UNIT
		MIN	TYP‡	MAX	MIN	
V _{IK}	V _{CC} = MIN, I _I = -12 mA	-1.5		-1.5		V
V _{OH}	V _{CC} = MIN, V _{IH} = 2 V, V _{IL} = 0.8 V, I _{OH} = MAX	2.4	3.3	2.4	3.1	V
V _{OL}	V _{CC} = MIN, V _{IH} = 2 V, V _{IL} = 0.8 V, I _{OL} = 32 mA	0.4		0.4		V
I _{OZ}	V _{CC} = MAX, V _{IH} = 2 V, V _{IL} = 0.8 V, V _O = 2.4 V	40		40		µA
	V _{CC} = MAX, V _{IH} = 2 V, V _{IL} = 0.8 V, V _O = 0.4 V	-40		-40		
I _I	V _{CC} = MAX, V _I = 5.5 V	1		1		mA
I _{IH}	V _{CC} = MAX, V _I = 2.4 V	40		40		µA
I _{IL}	A Inputs V _{CC} = MAX, V _I = 0.5 V, Either \bar{G} input at 2 V	-40		-40		µA
	V _{CC} = MAX, V _I = 0.4 V, Both \bar{G} inputs at 0.4 V	-1.6		-1.6		
\bar{G} Inputs	V _{CC} = MAX, V _I = 0.4 V	-1.6		-1.6		mA
I _{OS} §	V _{CC} = MAX	-40	-130	-40	-130	mA
I _{CC}	V _{CC} = MAX, Data inputs = 0 V, Output controls = 4.5 V	59	77	59	77	mA

† For conditions shown as MIN or MAX, use the appropriate value specified under recommended operating conditions.

‡ All typical values are at V_{CC} = 5 V, T_A = 25°C.

§ Not more than one output should be shorted at a time.

switching characteristics, V_{CC} = 5 V, T_A = 25°C (see note 2)

PARAMETER	FROM (INPUT)	TO (OUTPUT)	TEST CONDITIONS	MIN	TYP	MAX	UNIT
t _{PLH}	Any	Y	R _L = 400 Ω, C _L = 50 pF			17	ns
t _{PHL}						16	ns
t _{PZH}						35	ns
t _{PZL}						37	ns
t _{PHZ}						11	ns
t _{PLZ}						27	ns

NOTE 2: See General Information Section for load circuits and voltage waveforms.

**TYPES SN54LS365A, SN54LS367A
SN74LS365A, SN74LS367A
HEX BUS DRIVERS WITH 3-STATE OUTPUTS**

recommended operating conditions

	SN54LS365A SN54LS367A			SN74LS365A SN74LS367A			UNIT
	MIN	NOM	MAX	MIN	NOM	MAX	
V _{CC} Supply voltage	4.5	5	5.5	4.75	5	5.25	V
V _{IH} High-level input voltage	2			2			V
V _{IL} Low-level input voltage	0.7			0.8			V
I _{OH} High-level output current	-1			-2.6			mA
I _{OL} Low-level output current	12			24			mA
T _A Operating free-air temperature	-55			125			0 70 °C

electrical characteristics over recommended operating free-air temperature range (unless otherwise noted)

PARAMETER	TEST CONDITIONS†	SN54LS365A SN54LS367A		SN74LS365A SN74LS367A		UNIT	
		MIN	TYP‡	MAX	MIN		TYP‡
V _{IK}	V _{CC} = MIN, I _I = -18 mA	-1.5		-1.5		V	
V _{OH}	V _{CC} = MIN, V _{IH} = 2 V, V _{IL} = MAX, I _{OH} = MAX	2.4	3.3	2.4	3.1	V	
V _{OL}	V _{CC} = MIN, V _{IH} = 2 V, V _{IL} = MAX, I _{OL} = 12 mA	0.25	0.4	0.25	0.4	V	
	V _{CC} = MIN, V _{IH} = 2 V, V _{IL} = 0.8 V, I _{OL} = 24 mA	0.35		0.5			
I _{OZ}	V _{CC} = MAX, V _{IH} = 2 V, V _{IL} = MAX, V _O = 2.4 V	20		20		μA	
	V _{CC} = MAX, V _{IH} = 2 V, V _{IL} = MAX, V _O = 0.4 V	-20		-20			
I _I	V _{CC} = MAX, V _I = 7 V	0.1		0.1		mA	
I _{IH}	V _{CC} = MAX, V _I = 2.7 V	20		20		μA	
I _{IL}	A Inputs	V _{CC} = MAX, V _I = 0.5 V, Either \bar{G} input at 2 V	-20		-20		μA
		V _{CC} = MAX, V _I = 0.4 V, Both \bar{G} inputs at 0.4 V	-0.4		-0.4		
	\bar{G} Inputs	V _{CC} = MAX, V _I = 0.4 V	-0.2		-0.2		mA
I _{OS} §	V _{CC} = MAX	-40	-225	-40	-225	mA	
I _{CC}	V _{CC} = MAX, Data inputs = 0 V, Output controls = 4.5 V,	14	24	14	24	mA	

† For conditions shown as MIN or MAX, use the appropriate value specified under recommended operating conditions.

‡ All typical values are at V_{CC} = 5 V, T_A = 25°C.

§ Not more than one output should be shorted at a time, and the duration of the short circuit should not exceed one second.

TYPES SN54LS365A, SN54LS367A
 SN74LS365A, SN74LS367A
 HEX BUS DRIVERS WITH 3-STATE OUTPUTS

switching characteristics, $V_{CC} = 5\text{ V}$, $T_A = 25^\circ\text{ C}$ (see note 2)

PARAMETER	FROM (INPUT)	TO (OUTPUT)	TEST CONDITIONS	MIN	TYP	MAX	UNIT
t_{PLH}	Any	Y	$R_L = 667\ \Omega$, $C_L = 45\ \text{pF}$	10	16		ns
t_{PHL}				9	22		ns
t_{PZH}				19	35		ns
t_{PZL}				24	40		ns
t_{PHZ}			$R_L = 667\ \Omega$, $C_L = 5\ \text{pF}$	30		ns	
t_{PLZ}				35		ns	

NOTE 2: See General Information Section for load circuits and voltage waveforms.

**TYPES SN54LS366A, SN54LS368A
SN74LS366A, SN74LS368A
HEX BUS DRIVERS WITH 3-STATE OUTPUTS**

recommended operating conditions

	SN74LS366A SN74LS368A			SN54LS366A SN54LS368A			UNIT
	MIN	NOM	MAX	MIN	NOM	MAX	
V _{CC} Supply voltage	4.5	5	5.5	4.75	5	5.25	V
V _{IH} High-level input voltage	2			2			V
V _{IL} Low-level input voltage	0.7			0.8			V
I _{OH} High-level output current	-1			-2.6			mA
I _{OL} Low-level output current	12			24			mA
T _A Operating free-air temperature	-55			0			70 °C

electrical characteristics over recommended operating free-air temperature range (unless otherwise noted)

PARAMETER	TEST CONDITIONS†	SN54LS366A SN54LS368A		SN74LS366A SN74LS368A		UNIT
		MIN	TYP‡	MAX	MIN	
V _{IK}	V _{CC} = MIN, I _I = -18 mA	-1.5		-1.5		V
V _{OH}	V _{CC} = MIN, V _{IH} = 2 V, V _{IL} = MAX, I _{OH} = MAX	2.4	3.3	2.4	3.1	V
V _{OL}	V _{CC} = MIN, V _{IH} = 2 V, V _{IL} = MAX, I _{OL} = 12 mA	0.25		0.4		V
	V _{CC} = MIN, V _{IH} = 2 V, V _{IL} = 0.8 V, I _{OL} = 24 mA			0.35		
I _{OZ}	V _{CC} = MAX, V _{IH} = 2 V, V _{IL} = MAX, V _O = 2.4 V	20		20		μA
	V _{CC} = MAX, V _{IH} = 2 V, V _{IL} = MAX, V _O = 0.4 V	-20		-20		
I _I	V _{CC} = MAX, V _I = 7 V	0.1		0.1		mA
I _{IH}	V _{CC} = MAX, V _I = 2.7 V	20		20		μA
I _{IL}	A Inputs V _{CC} = MAX, V _I = 0.5 V, Either \bar{G} input at 2 V	-20		-20		μA
	V _{CC} = MAX, V _I = 0.4 V, Both \bar{G} inputs at 0.4 V	-0.4		-0.4		
\bar{G} Inputs	V _{CC} = MAX, V _I = 0.4 V	-0.2		-0.2		mA
I _{OS} §	V _{CC} = MAX	-40	-225	-40	-225	mA
I _{CC}	V _{CC} = MAX, Data inputs = 0 V, Output controls = 4.5 V,	12	21	12	21	mA

† For conditions shown as MIN or MAX, use the appropriate value specified under recommended operating conditions.

‡ All typical values are at V_{CC} = 5 V, T_A = 25°C.

§ Not more than one output should be shorted at a time, and the duration of the short circuit should not exceed one second.

3 TTL DEVICES

TYPES SN54LS366A, SN54LS368A
 SN74LS366A, SN74LS368A
 HEX BUS DRIVERS WITH 3-STATE OUTPUTS

switching characteristics, $V_{CC} = 5\text{ V}$, $T_A = 25^\circ\text{C}$ (see note 2)

PARAMETER	FROM (INPUT)	TO (OUTPUT)	TEST CONDITIONS	MIN	TYP	MAX	UNIT	
t_{PLH}	Any	Y	$R_L = 667\ \Omega$, $C_L = 45\ \text{pF}$		7	15	ns	
t_{PHL}					12	18	ns	
t_{PZH}					18	35	ns	
t_{PZL}					28	45	ns	
t_{PHZ}			$R_L = 667\ \Omega$, $C_L = 5\ \text{pF}$			32		ns
t_{PLZ}						35		ns

NOTE 2: See General Information Section for load circuits and voltage waveforms.



TTL DEVICES

TYPES SN54LS373, SN54LS374, SN54S373, SN54S374, SN74LS373, SN74LS374, SN74S373, SN74S374

OCTAL D-TYPE TRANSPARENT LATCHES AND EDGE-TRIGGERED FLIP-FLOPS

OCTOBER 1975—REVISED APRIL 1985

- Choice of 8 Latches or 8 D-Type Flip-Flops In a Single Package
- 3-State Bus-Driving Outputs
- Full Parallel-Access for Loading
- Buffered Control Inputs
- Clock/Enable Input Has Hysteresis to Improve Noise Rejection ('S373 and 'S374)
- P-N-P Inputs Reduce D-C Loading on Data Lines ('S373 and 'S374)

SN54LS373, SN54LS374, SN54S373,
SN54S374 ... J PACKAGE
SN74LS373, SN74LS374, SN74S373,
SN74S374 ... DW, J OR N PACKAGE

(TOP VIEW)

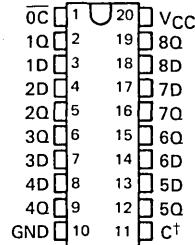

SN54LS373, SN54LS374, SN54S373,
SN54S374 ... FK PACKAGE
SN74LS373, SN74LS374, SN74S373,
SN74S374 ... FN PACKAGE

(TOP VIEW)

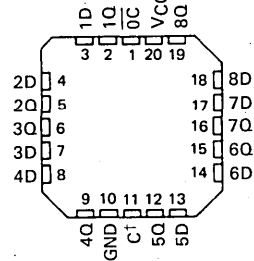

'LS373, 'S373
FUNCTION TABLE

OUTPUT ENABLE	ENABLE LATCH	D	OUTPUT
L	H	H	H
L	H	L	L
L	L	X	Q ₀
H	X	X	Z

'LS374, 'S374
FUNCTION TABLE

OUTPUT ENABLE	CLOCK	D	OUTPUT
L	↑	H	H
L	↑	L	L
L	L	X	Q ₀
H	X	X	Z

description

These 8-bit registers feature three-state outputs designed specifically for driving highly-capacitive or relatively low-impedance loads. The high-impedance third state and increased high-logic-level drive provide these registers with the capability of being connected directly to and driving the bus lines in a bus-organized system without need for interface or pull-up components. They are particularly attractive for implementing buffer registers, I/O ports, bidirectional bus drivers, and working registers.

The eight latches of the 'LS373 and 'S373 are transparent D-type latches meaning that while the enable (C) is high the Q outputs will follow the data (D) inputs. When the enable is taken low the output will be latched at the level of the data that was set up.

†C for 'LS373 and 'S373; CLK for 'LS374 and 'S374.

PRODUCTION DATA
This document contains information current as of publication date. Products conform to specifications per the terms of Texas Instruments standard warranty. Production processing does not necessarily include testing of all parameters.

**TEXAS
INSTRUMENTS**

POST OFFICE BOX 225012 • DALLAS, TEXAS 75262

3

TTL DEVICES

TYPES SN54LS373, SN54LS374, SN54S373, SN54S374, SN74LS373, SN74LS374, SN74S373, SN74S374 OCTAL D-TYPE TRANSPARENT LATCHES AND EDGE-TRIGGERED FLIP-FLOPS

description (continued)

The eight flip-flops of the 'LS374 and 'S374 are edge-triggered D-type flip-flops. On the positive transition of the clock, the Q outputs will be set to the logic states that were setup at the D inputs.

Schmitt-trigger buffered inputs at the enable/clock lines of the 'S373 and 'S374 devices, simplify system design as ac and dc noise rejection is improved by typically 400 mV due to the input hysteresis. A buffered output control input can be used to place the eight outputs in either a normal logic state (high or low logic levels) or a high-impedance state. In the high-impedance state the outputs neither load nor drive the bus lines significantly.

The output control does not affect the internal operation of the latches or flip-flops. That is, the old data can be retained or new data can be entered even while the outputs are off.

logic diagrams

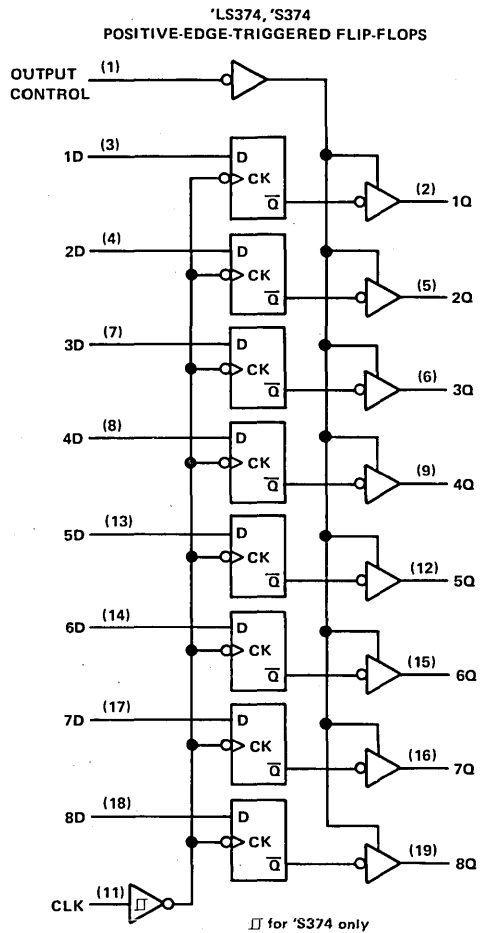
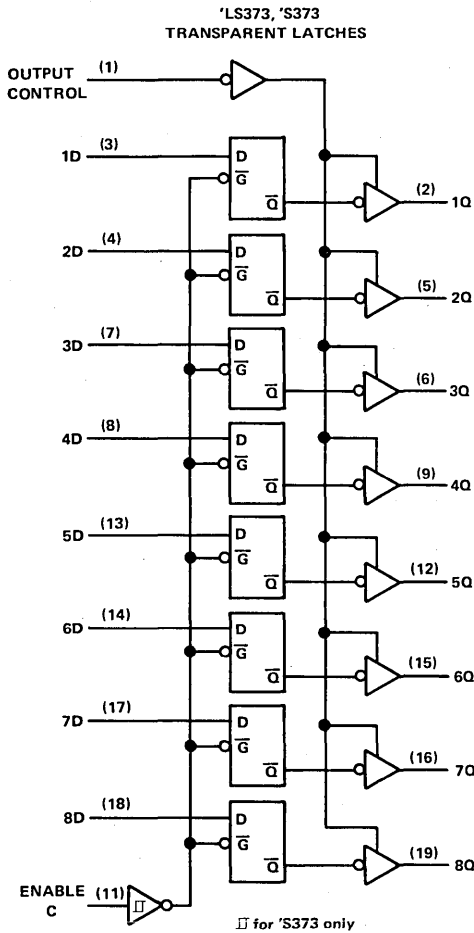

Pin numbers shown on logic notation are for DW, J or N packages.

TYPES SN54LS373, SN54LS374, SN74LS373, SN74LS374
 OCTAL D-TYPE TRANSPARENT LATCHES AND
 EDGE-TRIGGERED FLIP-FLOPS

schematic of inputs and outputs

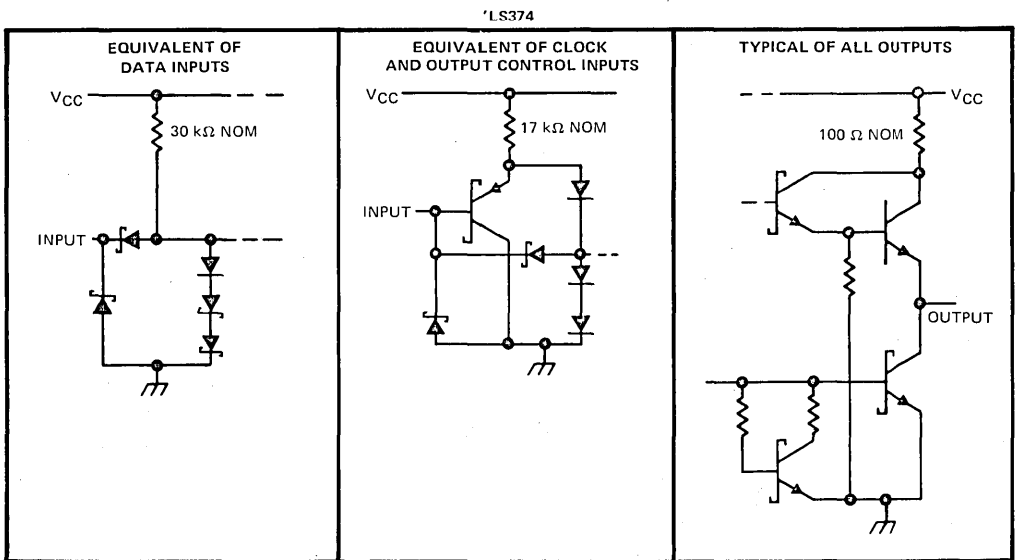
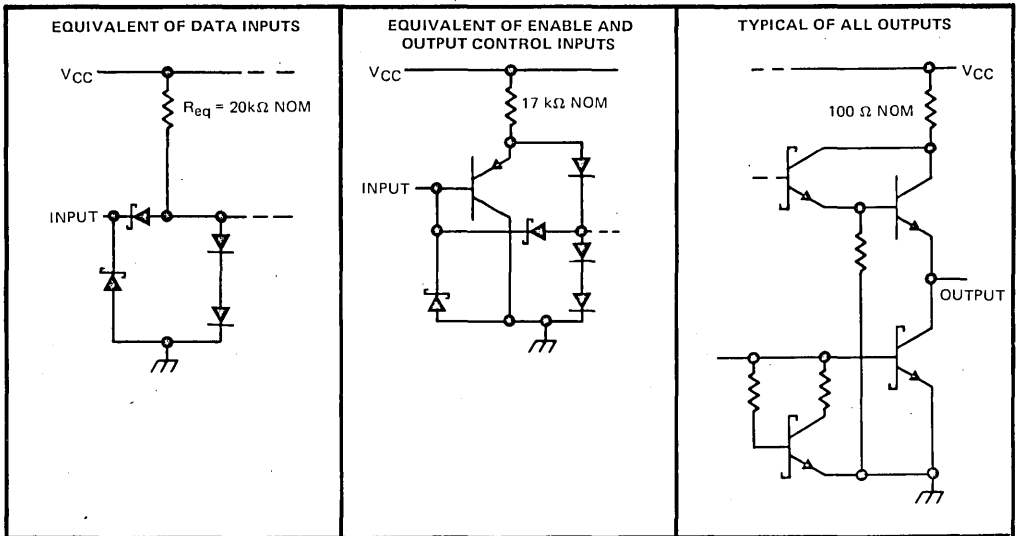

3

TTL DEVICES

TYPES SN54LS373, SN54LS374, SN74LS373, SN74LS374

OCTAL D-TYPE TRANSPARENT LATCHES AND

EDGE-TRIGGERED FLIP-FLOPS

absolute maximum ratings over operating free-air temperature range (unless otherwise noted)

Supply voltage, V_{CC} (see Note 1)	7 V
Input voltage	7 V
Off-state output voltage	5.5 V
Operating free-air temperature range: SN54LS'	-55°C to 125°C
SN74LS'	0°C to 70°C
Storage temperature range	-65°C to 150°C

NOTE 1: Voltage values are with respect to network ground terminal.

recommended operating conditions

		SN54LS'			SN74LS'			UNIT
		MIN	NOM	MAX	MIN	NOM	MAX	
V_{CC}	Supply voltage	4.5	5	5.5	4.75	5	5.25	V
V_{OH}	High-level output voltage			5.5			5.5	V
I_{OH}	High-level output current			-1			-2.6	mA
I_{OL}	Low-level output current			12			24	mA
t_w	Pulse duration	CLK high		15			15	ns
		CLK low		15			15	
t_{su}	Data setup time	'LS373		5↓			5↓	ns
		'LS374		20↑			20↑	
t_h	Data hold time	'LS373		20↓			20↓	ns
		'LS374↑		0↑			0↑	
T_A	Operating free-air temperature	-55		125	0		70	°C

† The t_h specification applies only for data frequency below 10 MHz. Designs above 10 MHz should use a minimum of 5 ns.

electrical characteristics over recommended operating free-air temperature range (unless otherwise noted)

PARAMETER	TEST CONDITIONS†	SN54LS'			SN74LS'			UNIT
		MIN	TYP‡	MAX	MIN	TYP‡	MAX	
V_{IH}	High-level input voltage	2			2			V
V_{IL}	Low-level input voltage			0.7			0.8	V
V_{IK}	Input clamp voltage			-1.5			-1.5	V
V_{OH}	High-level output voltage	$V_{CC} = \text{MIN}, I_I = -18 \text{ mA}$						V
V_{OL}	Low-level output voltage	$V_{CC} = \text{MIN}, V_{IH} = 2 \text{ V}, V_{IL} = V_{ILmax}, I_{OH} = \text{MAX}$		2.4	3.4	2.4	3.1	V
		$V_{CC} = \text{MIN}, V_{IH} = 2 \text{ V}, V_{IL} = V_{ILmax}$				0.25	0.4	
						0.25	0.4	V
						0.35	0.5	V
I_{OZH}	Off-state output current, high-level voltage applied	$V_{CC} = \text{MAX}, V_{IH} = 2 \text{ V}, V_O = 2.7 \text{ V}$				20	20	μA
I_{OZL}	Off-state output current, low-level voltage applied	$V_{CC} = \text{MAX}, V_{IH} = 2 \text{ V}, V_O = 0.4 \text{ V}$				-20	-20	μA
I_I	Input current at maximum input voltage	$V_{CC} = \text{MAX}, V_I = 7 \text{ V}$				0.1	0.1	mA
I_{IH}	High-level input current	$V_{CC} = \text{MAX}, V_I = 2.7 \text{ V}$				20	20	μA
I_{IL}	Low-level input current	$V_{CC} = \text{MAX}, V_I = 0.4 \text{ V}$				-0.4	-0.4	mA
I_{OS}	Short-circuit output current§	$V_{CC} = \text{MAX}$		-30	-130	-30	-130	mA
I_{CC}	Supply current	$V_{CC} = \text{MAX},$						mA
		Output control at 4.5 V	'LS373	24	40	24	40	
			'LS374	27	40	27	40	

† For conditions shown as MIN or MAX, use the appropriate value specified under recommended operating conditions.

‡ All typical values are at $V_{CC} = 5 \text{ V}, T_A = 25^\circ \text{C}$.

§ Not more than one output should be shorted at a time and duration of the short circuit should not exceed one second.

TYPES SN54LS373, SN54LS374, SN74LS373, SN74LS374 OCTAL D-TYPE TRANSPARENT LATCHES AND EDGE-TRIGGERED FLIP-FLOPS

switching characteristics, $V_{CC} = 5\text{ V}$, $T_A = 25^\circ\text{C}$

PARAMETER	FROM (INPUT)	TO (OUTPUT)	TEST CONDITIONS		'LS373			'LS374			UNIT	
					MIN	TYP	MAX	MIN	TYP	MAX		
f_{\max}			$C_L = 45\text{ pF}$, $R_L = 667\ \Omega$ See Notes 2 and 3					35	50		MHz	
t_{PLH}	Data	Any Q			12	18						ns
t_{PHL}					12	18						
t_{PLH}	Clock or enable	Any Q			20	30			15	28		ns
t_{PHL}					18	30			19	28		
t_{PZH}	Output Control	Any Q			15	28			20	26		ns
t_{PZL}					25	36			21	28		
t_{PHZ}	Output Control	Any Q			$C_L = 5\text{ pF}$, $R_L = 667\ \Omega$ See Note 3	SN54	28	32			28	32
			SN74	15		25			15	28		
t_{PLZ}	Output Control	Any Q			12	20			12	20	ns	

- NOTES: 2. Maximum clock frequency is tested with all outputs loaded.
3. See General Information Section for load circuits and voltage waveforms.

f_{\max} = maximum clock frequency

t_{PLH} = propagation delay time, low-to-high-level output

t_{PHL} = propagation delay time, high-to-low-level output

t_{PZH} = output enable time to high level

t_{PZL} = output enable time to low level

t_{PHZ} = output disable time from high level

t_{PLZ} = output disable time from low level

TYPES SN54S373, SN54S374, SN74S373, SN74S374 OCTAL D-TYPE TRANSPARENT LATCHES AND EDGE-TRIGGERED FLIP-FLOPS

schematic of inputs and outputs

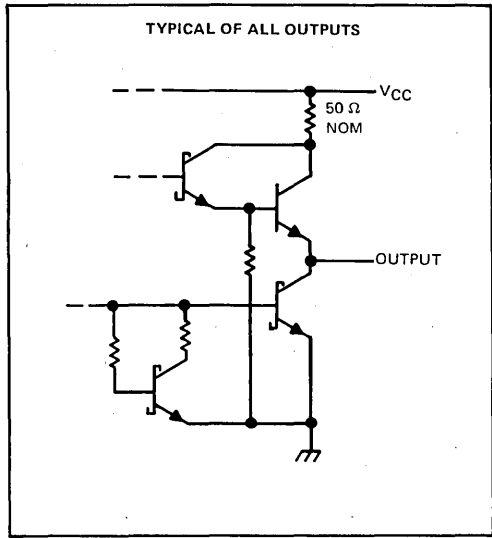
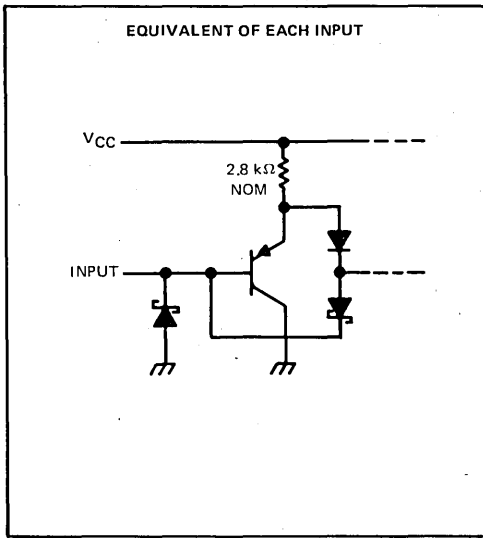

3

TTL DEVICES

absolute maximum ratings over operating free-air temperature range (unless otherwise noted)

Supply voltage, V_{CC} (see Note 1)	7 V
Input voltage	5.5 V
Off-state output voltage	5.5 V
Operating free-air temperature range: SN54S*	-55°C to 125°C
SN74S*	0°C to 70°C
Storage temperature range	-65°C to 150°C

NOTE 1: Voltage values are with respect to network ground terminal.

recommended operating conditions

		SN54S*			SN74S*			UNIT
		MIN	NOM	MAX	MIN	NOM	MAX	
Supply voltage, V_{CC}		4.5	5	5.5	4.75	5	5.25	V
High-level output voltage, V_{OH}				5.5			5.5	V
High-level output current, I_{OH}				-2			-6.5	mA
Width of clock/enable pulse, t_w	High	6			6			ns
	Low	7.3			7.3			
Data setup time, t_{su}	'S373	0↓			0↓			ns
	'S374	5↑			5↑			
Data hold time, t_h	'S373	10↓			10↓			ns
	'S374	2↑			2↑			
Operating free-air temperature, T_A		-55		125	0		70	°C

TYPES SN54S373, SN54S374, SN74S373, SN74S374 OCTAL D-TYPE TRANSPARENT LATCHES AND EDGE-TRIGGERED FLIP-FLOPS

electrical characteristics over recommended operating free-air temperature range (unless otherwise noted)

PARAMETER		TEST CONDITIONS†				MIN	TYP‡	MAX	UNIT
V _{IH}						2			V
V _{IL}								0.8	V
V _{IK}		V _{CC} = MIN, I _I = -18 mA						-1.2	V
V _{OH}	SN54S*	V _{CC} = MIN, V _{IH} = 2 V, V _{IL} = 0.8 V, I _{OH} = MAX				2.4	3.4		V
	SN74S*					2.4	3.1		
V _{OL}		V _{CC} = MIN, V _{IH} = 2 V, V _{IL} = 0.8 V, I _{OL} = 20 mA						0.5	V
I _{OZH}		V _{CC} = MAX, V _{IH} = 2 V, V _O = 2.4 V						50	μA
I _{OZL}		V _{CC} = MAX, V _{IH} = 2 V, V _O = 0.5 V						-50	μA
I _I		V _{CC} = MAX, V _I = 5.5 V						1	mA
I _{IH}		V _{CC} = MAX, V _I = 2.7 V						50	μA
I _{IL}		V _{CC} = MAX, V _I = 0.5 V						-250	μA
I _{OS} §		V _{CC} = MAX				-40		-100	mA
I _{CC}	V _{CC} = MAX	'S373	outputs high					160	mA
			outputs low					160	
			outputs disabled					190	
		'S374	outputs high					110	
			outputs low					140	
			outputs disabled					160	

† For conditions shown as MIN or MAX, use the appropriate value specified under recommended operating conditions.

‡ All typical values are at V_{CC} = 5 V, T_A = 25°C.

§ Not more than one output should be shorted at a time and duration of the short-circuit should not exceed one second.

switching characteristics, V_{CC} = 5 V, T_A = 25°C

PARAMETER	FROM (INPUT)	TO (OUTPUT)	TEST CONDITIONS	'S373			'S374			UNIT
				MIN	TYP	MAX	MIN	TYP	MAX	
f _{max}			C _L = 15 pF, R _L = 280 Ω, See Notes 2 and 4				75	100		MHz
t _{PLH}	Data	Any Q		7	12					ns
t _{PHL}				7	12					
t _{PLH}	Clock or enable	Any Q		7	14	8	15			ns
t _{PHL}				12	18	11	17			
t _{PZH}	Output	Any Q		8	15	8	15			ns
t _{PZL}	Control		11	18	11	18				
t _{PHZ}	Output	Any Q	C _L = 5 pF, R _L = 280 Ω, See Note 3			6	9	5	9	ns
t _{PLZ}			Control	8	12	7	12			

NOTES: 2. Maximum clock frequency is tested with all outputs loaded.

4. See General Information Section for load circuits and voltage waveforms.

f_{max} = maximum clock frequency

t_{PLH} = propagation delay time, low-to-high-level output

t_{PHL} = propagation delay time, high-to-low-level output

t_{PZH} = output enable time to high level

t_{PZL} = output enable time to low level

t_{PHZ} = output disable time from high level

t_{PLZ} = output disable time from low level

3

TTL DEVICES

**TYPES SN54LS373, SN54LS374, SN54S373, SN54S374,
SN74LS373, SN74LS374, SN74S373, SN74S374
OCTAL D-TYPE TRANSPARENT LATCHES AND EDGE-TRIGGERED FLIP-FLOPS**

TYPICAL APPLICATION DATA

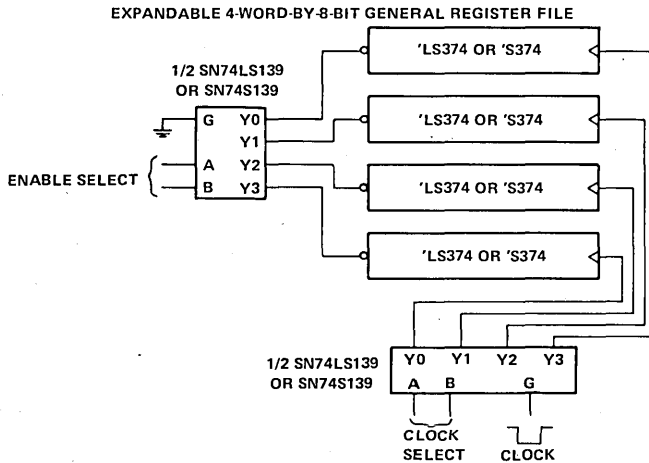
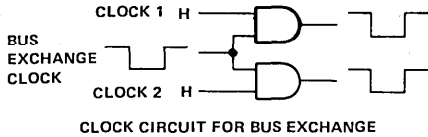
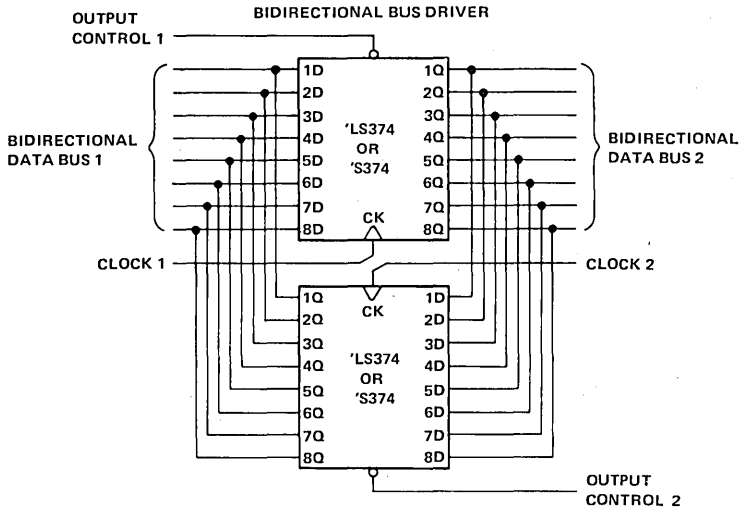

TYPES SN54LS375, SN74LS375 4-BIT BISTABLE LATCHES

OCTOBER 1976—REVISED DECEMBER 1983

- Supply Voltage and Ground on Corner Pins To Simplify P-C Board Layout

logic

FUNCTION TABLE
(EACH LATCH)

INPUTS		OUTPUTS	
D	G	Q	\bar{Q}
L	H	L	H
H	H	H	L
X	L	Q_0	\bar{Q}_0

H = high level, L = low level, X = irrelevant
 Q_0 = the level of Q before the high-to-low transition of C.

logic diagram (each latch)

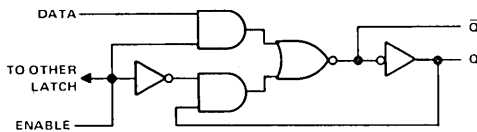

description

The SN54LS375 and SN74LS375 bistable latches are electrically and functionally identical to the SN54LS75 and SN74LS75, respectively. Only the arrangement of the terminals has been changed in the SN54LS375 and SN74LS375.

These latches are ideally suited for use as temporary storage for binary information between processing units and input/output or indicator units. Information present at a data (D) input is transferred to the Q output when the enable (C) is high and the Q output will follow the data input as long as the enable remains high. When the enable goes low, the information (that was present at the data input at the time the transition occurred) is retained at the Q output until the enable goes high.

These circuits are completely compatible with all popular TTL or DTL families. All inputs are diode-clamped to minimize transmission-line effects and simplify system design. The SN54LS375 is characterized for operation over the full military temperature range of -55°C to 125°C ; SN74LS375 is characterized for operation from 0°C to 70°C .

absolute maximum ratings over operating free-air temperature range (unless otherwise noted)

Supply voltage, V_{CC} (see Note 1)	7 V
Input voltage	7 V
Operating free-air temperature range: SN54LS375	-55°C to 125°C
SN74LS375	0°C to 70°C
Storage temperature range	-65°C to 150°C

NOTE 1: Voltage values are with respect to network ground terminal.

SN54LS375 ... J OR W PACKAGE
SN74LS375 ... D, J OR N PACKAGE
(TOP VIEW)

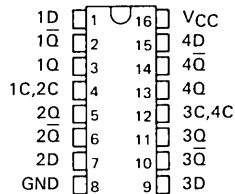

SN54LS375 ... FK PACKAGE
SN74LS375 ... FN PACKAGE
(TOP VIEW)

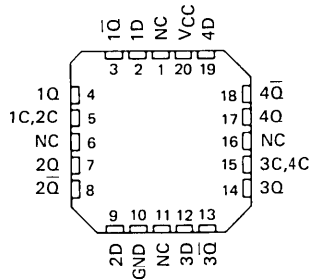

NC - No internal connection

schematics of inputs and outputs

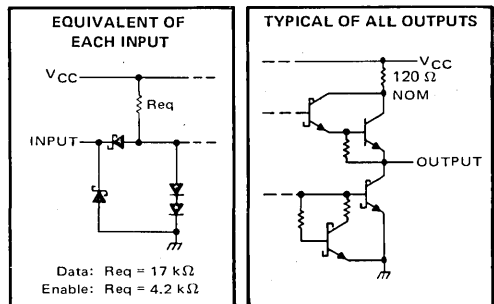

PRODUCTION DATA
This document contains information current as of publication date. Products conform to specifications per the terms of Texas Instruments standard warranty. Production processing does not necessarily include testing of all parameters.

TEXAS
INSTRUMENTS

POST OFFICE BOX 225012 • DALLAS, TEXAS 75265

3-1029

3
TTL DEVICES

TYPES SN54LS375, SN74LS375 4-BIT BISTABLE LATCHES

recommended operating conditions

		SN54LS375			SN74LS375			UNIT
		MIN	NOM	MAX	MIN	NOM	MAX	
V _{CC}	Supply voltage	4.5	5	5.5	4.75	5	5.25	V
V _{IH}	High-level input voltage	2			2			V
V _{IL}	Low-level input voltage			0.7			0.8	V
I _{OH}	High-level output current			-0.4			-0.4	mA
I _{OL}	Low-level output current			4			8	mA
t _w	Width of enabling pulse	20			20			ns
t _{setup}	Setup time	20			20			ns
t _{hold}	Hold time	0			0			ns
T _A	Operating free-air temperature	-55		125	0		70	°C

electrical characteristics over recommended operating free-air temperature range (unless otherwise noted)

PARAMETER	TEST CONDITIONS †	SN54LS375			SN74LS375			UNIT
		MIN	TYP ‡	MAX	MIN	TYP ‡	MAX	
V _{IK}	V _{CC} = MIN, I _I = -18 mA			-1.5			-1.5	V
V _{OH}	V _{CC} = MIN, V _{IH} = 2 V, V _{IL} = MAX I _{OH} = -0.4 mA	2.5	3.5		2.7	3.5		V
V _{OL}	V _{CC} = MIN, V _{IH} = 2 V, V _{IL} = MAX I _{OL} = 4 mA I _{OL} = 8 mA		0.25	0.4		0.25	0.5	V
I _I	V _{CC} = MAX, V _I = 7 V			0.1			0.1	mA
I _{IH}	V _{CC} = MAX, V _I = 2.7 V	D input		20	20			μA
		C input		80	80			
I _{IL}	V _{CC} = MAX, V _I = 0.4 V	D input		-0.4	-0.4			mA
		C input		-1.6	-1.6			
I _{OS} §	V _{CC} = MAX	-20		-100	-20		-100	mA
I _{CC}	V _{CC} = MAX, See Note 2		6.3	12		6.3	12	mA

† For conditions shown as MIN or MAX, use the appropriate value specified under recommended operating conditions.

‡ All typical values are at V_{CC} = 5 V, T_A = 25°C.

§ Not more than one output should be shorted at a time.

NOTE 2: I_{CC} is tested with all inputs grounded and all outputs open.

switching characteristics, V_{CC} = 5 V, T_A = 25°C (see note 3)

PARAMETER ◊	FROM (INPUT)	TO (OUTPUT)	TEST CONDITIONS		MIN	TYP	MAX	UNIT
t _{PLH}	D	Q	R _L = 2 kΩ,	C _L = 15 pF	15	27		ns
t _{PHL}					9	17		
t _{PLH}	D	Q̄			12	20		ns
t _{PHL}					7	15		
t _{PLH}	D	Q			15	27		ns
t _{PHL}					14	25		
t _{PLH}	C	Q̄	16	30		ns		
t _{PHL}			7	15				

◊ t_{PLH} = propagation delay time, low-to-high-level output

t_{PHL} = propagation delay time, high-to-low-level output

NOTE 3: See General Information Section for load circuits and voltage waveforms.

3

TTL DEVICES

TYPES SN54376, SN74376 QUADRUPLE J-K FLIP-FLOPS

OCTOBER 1976—REVISED DECEMBER 1983

- Four J-K Flip-Flops in a Single Package . . . Can Reduce FF Package Count by 50%
- Common Positive-Edge-Triggered Clocks with Hysteresis . . . Typically 200 mV
- Fully Buffered Outputs
- Typical Clock Input Frequency . . . 45 MHz

SN54376 . . . J OR W PACKAGE
SN74376 . . . J OR N PACKAGE
(TOP VIEW)

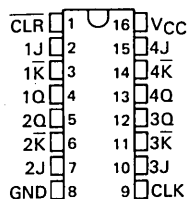

description

These quadruple TTL J-K flip-flops incorporate a number of third-generation IC features that can simplify system design and reduce flip-flop package count by as much as 50%. They feature hysteresis at the clock input, fully buffered outputs, and direct clear capability. The positive-edge-triggered SN54376 and SN74376 are directly compatible with most Series 54/74 MSI registers.

The SN54376 is characterized for operation over the full military temperature range of -55°C to 125°C ; the SN74376 is characterized for operation from 0°C to 70°C .

FUNCTION TABLE (EACH FLIP-FLOP)

COMMON INPUTS		INPUTS		OUTPUT
CLEAR	CLOCK	J	\bar{K}	Q
L	X	X	X	L
H	\uparrow	L	H	Q_0
H	\uparrow	H	H	H
H	\uparrow	L	L	L
H	\uparrow	H	L	TOGGLE
H	L	X	X	Q_0

logic symbol

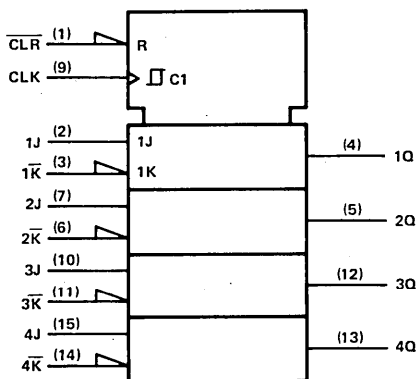

Pin numbers shown on logic notation are for J or N packages.

schematics of inputs and outputs

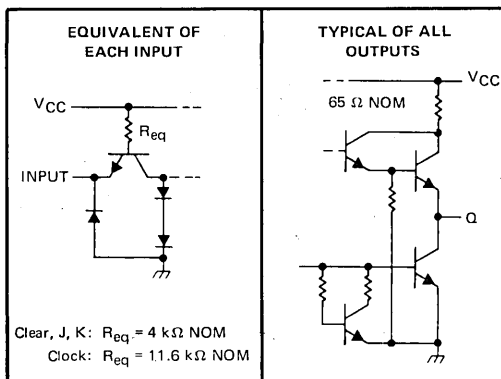

Resistor values shown are nominal.

PRODUCTION DATA
This document contains information current as of publication date. Products conform to specifications per the terms of Texas Instruments standard warranty. Production processing does not necessarily include testing of all parameters.

TEXAS INSTRUMENTS
POST OFFICE BOX 225012 • DALLAS, TEXAS 75265

3-1031

3

TTL DEVICES

TYPES SN54376, SN74376

QUADRUPLE J-K FLIP-FLOPS

absolute maximum ratings over operating free-air temperature range (unless otherwise noted)

Supply voltage, V_{CC} (see Note 1)7 V
Input voltage5.5 V
Operating free-air temperature range: SN54376- 5.5°C to 125°C
SN743760°C to 70°C
Storage temperature range- 65°C to 150°C

NOTE: Voltage values are with respect to network ground terminal.

recommended operating conditions

		SN54376			SN74376			UNIT
		MIN	NOM	MAX	MIN	NOM	MAX	
Supply voltage, V_{CC}		4.5	5	5.5	4.75	5	5.25	V
High-level output current, I_{OH}				-800			-800	μ A
Low-level output current, I_{OL}				16			16	mA
Clock frequency		0		30	0		30	MHz
Pulse width, t_w	Clock high	22			22			ns
	Clock low	12			12			
	Preset or clear low	12			12			
Setup time, t_{su}	J, K inputs	0†			0†			ns
	Clear inactive state	10†			10†			
Input hold time, t_h		20†			20†			ns
Operating free-air temperature, T_A		55		125	0		70	°C

† The arrow indicates the edge of the clock pulse used for reference: ↑ for the rising edge, ↓ for the falling edge.

electrical characteristics over recommended operating free-air temperature range (unless otherwise noted)

PARAMETER		TEST CONDITIONS†	MIN	TYP‡	MAX	UNIT
V_{IH}	High-level input voltage		2			V
V_{IL}	Low-level input voltage				0.8	V
V_{IK}	Input clamp voltage	$V_{CC} = \text{MIN}, I_I = -12 \text{ mA}$			-1.5	V
V_{OH}	High-level output voltage	$V_{CC} = \text{MIN}, V_{IH} = 2 \text{ V}, V_{IL} = 0.8 \text{ V}, I_{OH} = -800 \mu\text{A}$	2.4	3.4		V
V_{OL}	Low-level output voltage	$V_{CC} = \text{MIN}, V_{IH} = 2 \text{ V}, V_{IL} = 0.8 \text{ V}, I_{OL} = 16 \text{ mA}$		0.2	0.4	V
I_I	Input current at maximum input voltage	$V_{CC} = \text{MAX}, V_I = 5.5 \text{ V}$			1	mA
I_{IH}	High-level input current	$V_{CC} = \text{MAX}, V_I = 2.4 \text{ V}$			40	μ A
I_{IL}	Low-level input current	$V_{CC} = \text{MAX}, V_I = 0.4 \text{ V}$			-1.6	mA
I_{OS}	Short-circuit output current§	$V_{CC} = \text{MAX}$	-30		-85	mA
I_{CC}	Supply current	$V_{CC} = \text{MAX}$		52	74	mA

† For conditions shown as MIN or MAX, use the appropriate value specified under recommended operating conditions.

‡ All typical values are at $V_{CC} = 5 \text{ V}, T_A = 25^\circ\text{C}$.

§ Not more than one output should be shorted at a time.

switching characteristics, $V_{CC} = 5 \text{ V}, T_A = 25^\circ\text{C}$

PARAMETER		TEST CONDITIONS	MIN	TYP	MAX	UNIT
f_{max}	Maximum clock frequency	$C_L = 15 \text{ pF}, R_L = 400 \Omega,$ See Note 2	30	45		MHz
t_{PHL}	Propagation delay time, high-to-low-level output from clear			17	30	ns
t_{PLH}	Propagation delay time, low-to-high-level output from clock			22	35	ns
t_{PHL}	Propagation delay time, high-to-low-level output from clock			24	35	ns

NOTE 2: See General Information Section for load circuits and voltage waveforms.

TYPES SN54LS377, SN54LS378, SN54LS379, SN74LS377, SN74LS378, SN74LS379 OCTAL, HEX, AND QUAD D-TYPE FLIP-FLOPS WITH ENABLE

OCTOBER 1976—REVISED APRIL 1985

- 'LS377 and 'LS378 Contain Eight and Six Flip-Flops, Respectively, with Single-Rail Outputs
- 'LS379 Contains Four Flip-Flops with Double-Rail Outputs
- Individual Data Input to Each Flip-Flop
- Applications Include:
Buffer/Storage Registers
Shift Registers
Pattern Generators

description

These monolithic, positive-edge-triggered flip-flops utilize TTL circuitry to implement D-type flip-flop logic with an enable input. The 'LS377, 'LS378, and 'LS379 devices are similar to 'LS273, 'LS174, and 'LS175, respectively, but feature a common enable instead of a common clear.

Information at the D inputs meeting the setup time requirements is transferred to the Q outputs on the positive-going edge of the clock pulse if the enable input \bar{G} is low. Clock triggering occurs at a particular voltage level and is not directly related to the transition time of the positive-going pulse. When the clock input is at either the high or low level, the D input signal has no effect at the output. The circuits are designed to prevent false clocking by transitions at the \bar{G} input.

These flip-flops are guaranteed to respond to clock frequencies ranging from 0 to 30 MHz while maximum clock frequency is typically 40 megahertz. Typical power dissipation is 10 milliwatts per flip-flop.

FUNCTION TABLE
(EACH FLIP-FLOP)

INPUTS			OUTPUTS	
\bar{G}	CLOCK	DATA	Q	\bar{Q}
H	X	X	Q_0	\bar{Q}_0
L	↑	H	L	L
L	↑	L	L	H
X	L	X	Q_0	\bar{Q}_0

SN54LS377 ... J PACKAGE
SN74LS377 ... DW, J OR N PACKAGE
(TOP VIEW)

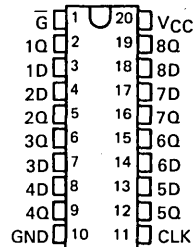

SN54LS377 ... FK PACKAGE
SN74LS377 ... FN PACKAGE
(TOP VIEW)

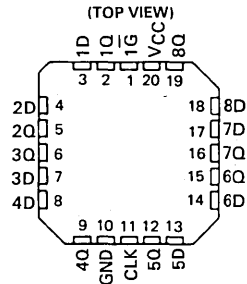

SN54LS378 ... J OR W PACKAGE
SN74LS378 ... D, J OR N PACKAGE
(TOP VIEW)

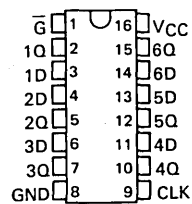

SN54LS378 ... FK PACKAGE
SN74LS378 ... FN PACKAGE
(TOP VIEW)

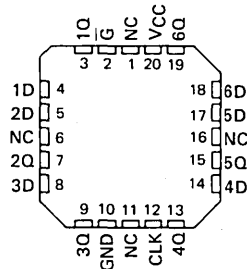

NC - No internal connection

PRODUCTION DATA

This document contains information current as of publication date. Products conform to specifications per the terms of Texas Instruments standard warranty. Production processing does not necessarily include testing of all parameters.



POST OFFICE BOX 225012 • DALLAS, TEXAS 75265

**TYPES SN54LS377, SN54LS378, SN54LS379
SN74LS377, SN74LS378, SN74LS379
OCTAL, HEX, AND QUAD D-TYPE FLIP-FLOPS WITH ENABLE**

SN54LS379 . . . J OR W PACKAGE
SN74LS379 . . . D, J OR N PACKAGE
(TOP VIEW)

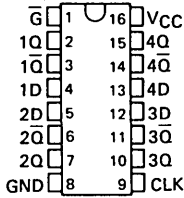

SN54LS379 . . . FK PACKAGE
SN74LS379 . . . FN PACKAGE
(TOP VIEW)

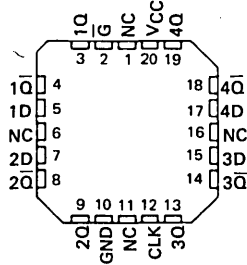

NC - No internal connection

logic diagram

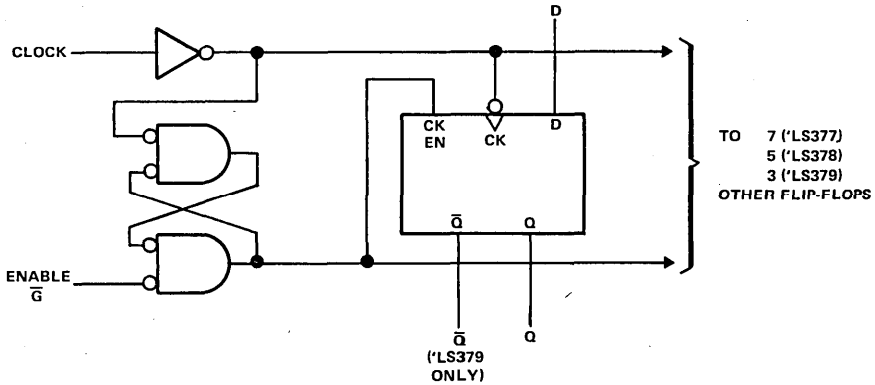

absolute maximum rating over operating free-air temperature range (unless otherwise noted)

Supply voltage, VCC (see Note 1)	7 V
Input voltage	7 V
Operating free-air temperature range: SN54LS*	-55°C to 125°C
SN74LS*	0°C to 70°C
Storage temperature range	-65°C to 150°C

NOTE 1: Voltage values are with respect to network ground terminal.

3 TTL DEVICES

TYPES SN54LS377, SN54LS378, SN54LS379,
SN74LS377, SN74LS378, SN74LS379
OCTAL, HEX, AND QUAD D-TYPE FLIP-FLOPS WITH ENABLE

schematics of inputs and outputs

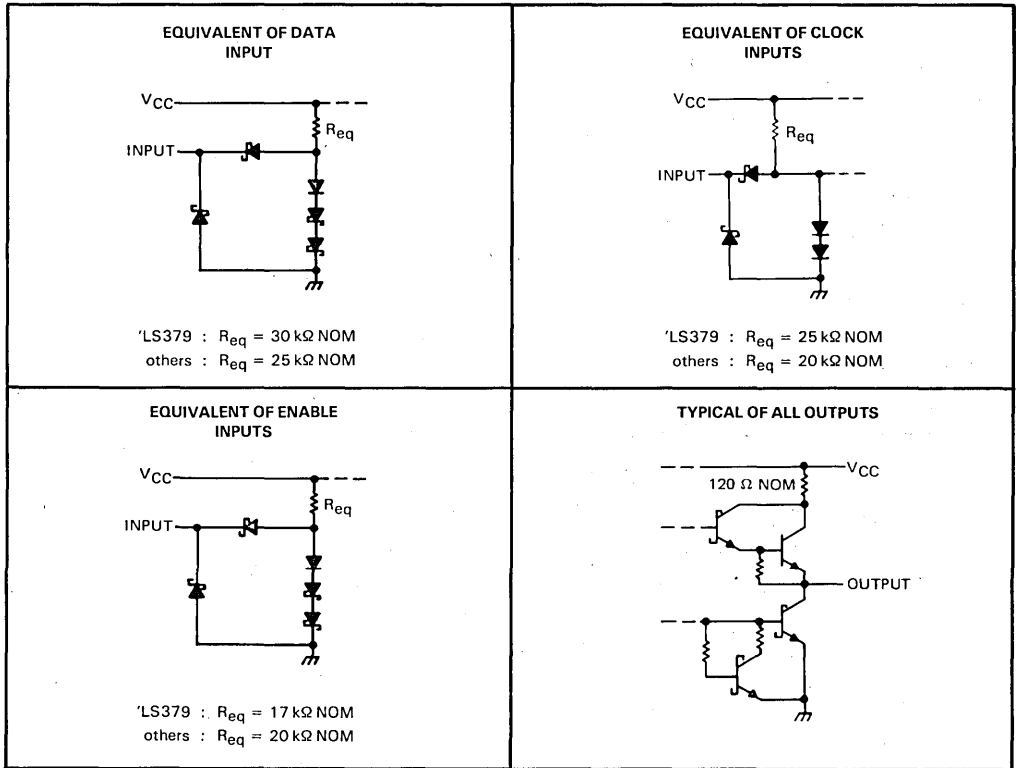

**TYPES SN54LS377, SN54LS378, SN54LS379,
SN74LS377, SN74LS378, SN74LS379
OCTAL, HEX, AND QUAD D-TYPE FLIP-FLOPS WITH ENABLE**

recommended operating conditions

	SN54LS*			SN74LS*			UNIT
	MIN	NOM	MAX	MIN	NOM	MAX	
Supply voltage, V_{CC}	4.5	5	5.5	4.75	5	5.25	V
High-level output current, I_{OH}	-400			-400			μ A
Low-level output current, I_{OL}	4			8			mA
Clock frequency, f_{clock}	0			30			MHz
Width of clock pulse, t_w	20			20			ns
Setup time, t_{su}	Data input			20†			
	Enable active-state			25†			
	Enable inactive-state			10†			
Hold time, t_h	Data and enable			5†			ns
Operating free-air temperature, T_A	-55		125	0		70	$^{\circ}$ C

† The arrow indicates that the rising edge of the clock pulse is used for reference.

electrical characteristics over recommended operating free-air temperature range (unless otherwise noted)

PARAMETER	TEST CONDITIONS†	SN54LS*			SN74LS*			UNIT	
		MIN	TYP‡	MAX	MIN	TYP‡	MAX		
V_{IH} High-level input voltage		2			2			V	
V_{IL} Low-level input voltage		0.7			0.8			V	
V_{IK} Input clamp voltage	$V_{CC} = \text{MIN}$, $I_I = -18 \text{ mA}$	-1.5			-1.5			V	
V_{OH} High-level output voltage	$V_{CC} = \text{MIN}$, $V_{IH} = 2 \text{ V}$, $V_{IL} = V_{IL \text{ max}}$, $I_{OH} = -400 \mu\text{A}$	2.5	3.5		2.7	3.5		V	
	$V_{CC} = \text{MIN}$, $V_{IH} = 2 \text{ V}$, $V_{IL} = V_{IL \text{ max}}$	0.25	0.4		0.25	0.4		V	
V_{OL} Low-level output voltage	$I_{OL} = 4 \text{ mA}$				0.35			0.5	
	$I_{OL} = 8 \text{ mA}$								
I_I Input current at maximum input voltage	$V_{CC} = \text{MAX}$, $V_I = 7 \text{ V}$	0.1			0.1			mA	
I_{IH} High-level input current	$V_{CC} = \text{MAX}$, $V_I = 2.7 \text{ V}$	20			20			μ A	
I_{IL} Low-level input current	$V_{CC} = \text{MAX}$, $V_I = 0.4 \text{ V}$	-0.4			-0.4			mA	
I_{OS} Short-circuit output current§	$V_{CC} = \text{MAX}$	-20	-100		-20	-100		mA	
I_{CC} Supply current	$V_{CC} = \text{MAX}$, See Note 2	'LS377		17	28	'LS378		17	28
		'LS378		13	22	'LS379		13	22
		'LS379		9	15			9	15

† For conditions shown as MIN or MAX, use the appropriate value specified under recommended operating conditions.

‡ All typical values are at $V_{CC} = 5 \text{ V}$, $T_A = 25^{\circ}\text{C}$.

§ Note more than one input should be shorted at a time, and duration of the short-circuit should not exceed one second.

NOTE 2: With all outputs open and ground applied to all data and enable inputs, I_{CC} is measured after a momentary ground, then 4.5 V, is applied to clock.

switching characteristics, $V_{CC} = 5 \text{ V}$, $T_A = 25^{\circ}\text{C}$

PARAMETER	TEST CONDITIONS	MIN	TYP	MAX	UNIT
f_{max} Maximum clock frequency	$C_L = 15 \text{ pF}$,	30	40		MHz
t_{PLH} Propagation delay time, low-to-high-level output from clock	$R_L = 2 \text{ k}\Omega$		17	27	ns
t_{PHL} Propagation delay time, high-to-low-level output from clock	See Note 3		18	27	ns

NOTE 3: See General Information Section for load circuits and voltage waveforms.

3 TTL DEVICES

TYPES SN54LS381A, SN54LS382, SN54S381, SN74LS381A, SN74LS382, SN74S381 ARITHMETIC LOGIC UNITS/FUNCTION GENERATORS

D2430, JANUARY 1981 — REVISED DECEMBER 1983

PIN DESIGNATIONS

DESIGNATION	PIN NOS.	FUNCTION
A3, A2, A1, A0	17, 19, 1, 3	WORD A INPUTS
B3, B2, B1, B0	16, 18, 2, 4	WORD B INPUTS
S2, S1, S0	7, 6, 5	FUNCTION-SELECT INPUTS
C_n	15	CARRY INPUT FOR ADDITION, INVERTED CARRY INPUT FOR SUBTRACTION
F3, F2, F1, F0	12, 11, 9, 8	FUNCTION OUTPUTS
\bar{P} ('LS381A 'S381 ONLY)	14	ACTIVE-LOW CARRY PROPAGATE OUTPUT
\bar{G} ('LS381A 'S381 ONLY)	13	ACTIVE-LOW CARRY GENERATE OUTPUT
$C_n + 4$ ('LS382 ONLY)	14	RIPPLE-CARRY OUTPUT
OVR ('LS382 ONLY)	13	OVERFLOW OUTPUT
V _{CC}	20	SUPPLY VOLTAGE
GND	10	GROUND

- Fully Parallel 4-Bit ALU's in 20-Pin Package for 0.300-Inch Row Spacing
- Ideally Suited for High-Density Economical Processors
- 'LS381A and 'S381 Feature \bar{G} and \bar{P} Outputs for Look-Ahead Carry Cascading
- 'LS382 Features Ripple Carry ($C_n + 4$) and Overflow (OVR) Outputs
- Arithmetic and Logic Operations Selected Specifically to Simplify System Implementation:
 - A Minus B
 - B Minus A
 - A Plus B
 - and Five Other Functions

description

The 'LS381A, 'S381 and 'LS382 are low-power Schottky and Schottky TTL arithmetic logic units (ALUs)/function generators that perform eight binary arithmetic/logic operations on two 4-bit words as shown in the function table. The exclusive-OR, AND, or OR function of the two Boolean variables is provided without the use of external circuitry. Also, the outputs can be cleared (low) or preset (high) as desired. The 'LS381A and 'S381 provide two cascade outputs (\bar{P} and \bar{G}) for expansion utilizing SN54S182/SN74S182 look-ahead carry generators. The 'LS382 provides a $C_n + 4$ output to ripple the carry to the C_n input of the next stage. The 'LS382 detects and indicates two's complement overflow condition via the OVR output. The overflow output is logically equivalent to $C_n + 3 \oplus C_n + 4$. When the 'LS382 is cascaded to handle word lengths longer than four bits in length, only the most significant overflow (OVR) output is used.

The SN54' Family is characterized for operation over the full military temperature range of -55°C to 125°C . The SN74' family is characterized for operation from 0°C to 70°C .

PRODUCTION DATA

This document contains information current as of publication date. Products conform to specifications per the terms of Texas Instruments standard warranty. Production processing does not necessarily include testing of all parameters.

**TEXAS
INSTRUMENTS**

POST OFFICE BOX 225012 • DALLAS, TEXAS 75265

SN54LS381A, SN54S381
... J PACKAGE
SN74LS381A, SN74S381
... DW, J OR N PACKAGE

(TOP VIEW)

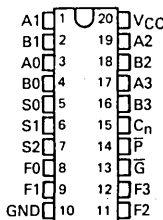

SN54LS381A, SN54S381
... FK PACKAGE
SN74LS381A, SN74S381
... FN PACKAGE

(TOP VIEW)

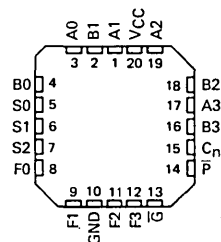

SN54LS382 ... J PACKAGE
SN74LS382 ...
DW, J OR N PACKAGE

(TOP VIEW)

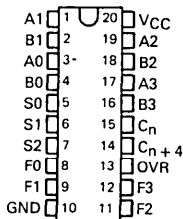

SN54LS382 ... FK PACKAGE
SN74LS382 ... FN PACKAGE

(TOP VIEW)

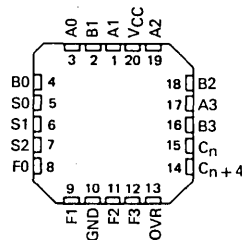

FUNCTION TABLE

SELECTION	ARITHMETIC/LOGIC		
S2	S1	S0	OPERATION
L	L	L	CLEAR
L	L	H	B MINUS A
L	H	L	A MINUS B
L	H	H	A PLUS B
H	L	L	A ⊕ B
H	L	H	A + B
H	H	L	AB
H	H	H	PRESET

H = high level, L = low level

TYPES SN54LS381A, SN54LS382, SN54S381, SN74LS381A, SN74LS382, SN74S381 ARITHMETIC LOGIC UNITS/FUNCTIONS GENERATORS

function table

Certain differences exist in the \bar{G} , \bar{P} ('LS381A, 'S381) and OVR, C_{n+4} ('LS382) function table compared with similar parts from other vendors. No differences exist in the arithmetic modes (B minus A, A minus B, and A plus B), where these outputs perform valuable cascade functions.

There are slight differences in the other modes (CLEAR, $A + B$, $A \oplus B$, AB, and PRESET), where these outputs are strictly "don't care."

This function table is a condensed version and assumes for A_n that $A0, A1, A2,$ and $A3$ inputs all agree and for B_n that $B0, B1, B2,$ and $B3$ inputs all agree. This table is intended to point out the response of these \bar{G} , \bar{P} ('LS381A, 'S381) and OVR, C_{n+4} ('LS382) outputs in all modes of operation to facilitate incoming inspection.

FUNCTION TABLE

ARITHMETIC/LOGIC OPERATION	INPUTS						OUTPUTS				('LS381A, 'S381)		('LS382)			
	S2	S1	S0	C _n	A _n	B _n	F3	F2	F1	F0	\bar{G}	\bar{P}	OVR	C _{n+4}		
CLEAR	L	L	L	X	X	X	L	L	L	L	H	H	H	L		
B MINUS A	L	L	H	L	L	L	H	H	H	H	H	L	L	L		
				L	L	H	H	H	H	L	L	L	H	L	H	
				L	H	L	L	L	L	L	L	H	H	L	L	L
				L	H	H	H	H	H	H	H	H	H	L	L	L
				H	L	L	L	L	L	L	L	L	H	L	L	H
				H	L	H	H	H	H	H	H	H	L	H	L	H
				H	H	L	L	L	L	L	L	H	H	H	L	L
A MINUS B	L	H	L	L	L	L	H	H	H	H	H	L	L	L		
				L	L	H	L	L	L	L	L	H	H	L	L	
				L	H	L	H	H	H	L	L	L	L	L	L	
				L	H	H	H	H	H	H	H	H	H	L	L	L
				H	L	L	L	L	L	L	L	H	H	L	L	H
				H	L	H	L	L	L	L	L	H	H	L	L	H
				H	H	L	L	L	L	L	L	L	H	L	L	H
A PLUS B	L	H	H	L	L	L	L	L	L	L	H	L	L	L		
				L	L	H	H	H	H	H	H	H	L	L	L	
				L	H	L	H	H	H	L	L	L	L	H	L	H
				L	H	H	H	H	H	L	L	L	H	H	L	L
				H	L	L	L	L	L	L	L	H	H	L	L	L
				H	L	H	L	L	L	L	L	L	H	L	L	H
				H	H	H	H	H	H	H	H	H	L	H	L	H
A \oplus B	H	L	L	X	L	L	L	L	L	L	H	H	L	L		
				L	L	H	H	H	H	H	H	H	L	H	H	
				L	L	L	H	H	H	H	H	H	L	L	L	
				L	H	L	H	H	H	H	H	H	L	L	L	
				X	H	H	L	H	H	H	H	H	L	H	H	
A + B	H	L	H	X	L	L	L	L	L	L	H	H	L	L		
				L	L	H	H	H	H	H	H	L	L	L		
				L	L	H	H	H	H	H	H	L	H	H		
				L	H	L	H	H	H	H	H	L	L	L		
				L	H	H	H	H	H	H	H	L	L	L		
AB	H	H	L	X	L	L	L	L	L	L	H	H	L	L		
				X	L	H	L	L	L	L	L	H	H	L	L	
				L	H	H	H	H	H	H	H	L	L	L		
				L	H	H	H	H	H	H	H	L	L	L		
PRESET	H	H	H	L	X	X	H	H	H	H	L	L	L			
				H	X	X	H	H	H	H	L	L	L			

TYPES SN54LS381A, SN54LS382, SN74LS381A, SN74LS382
 ARITHMETIC LOGIC UNITS/FUNCTION GENERATORS

logic diagram (positive logic)

'LS381A, 'LS382

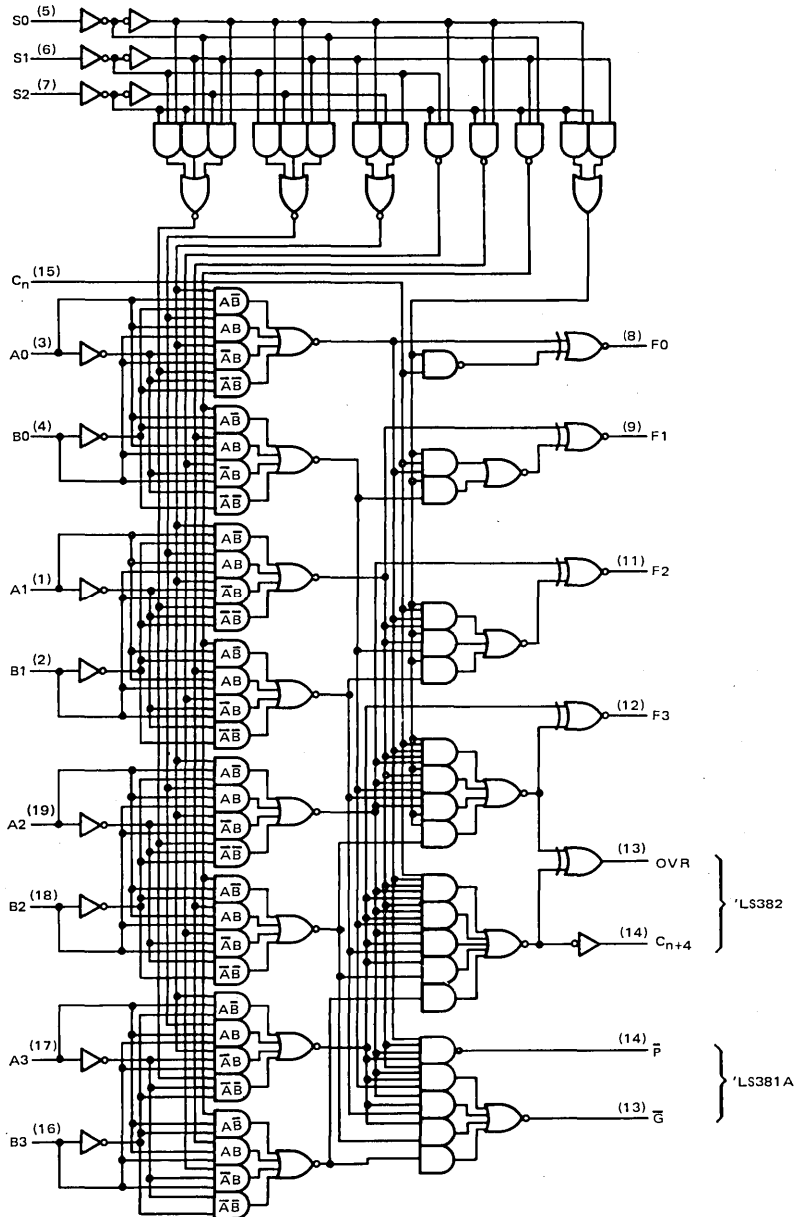

Pin numbers shown on logic notation are for DW, J or N packages.

3

TTL DEVICES

TYPES SN54S381, SN74S381
 ARITHMETIC LOGIC UNITS/FUNCTION GENERATORS

logic diagram and schematics of inputs and outputs

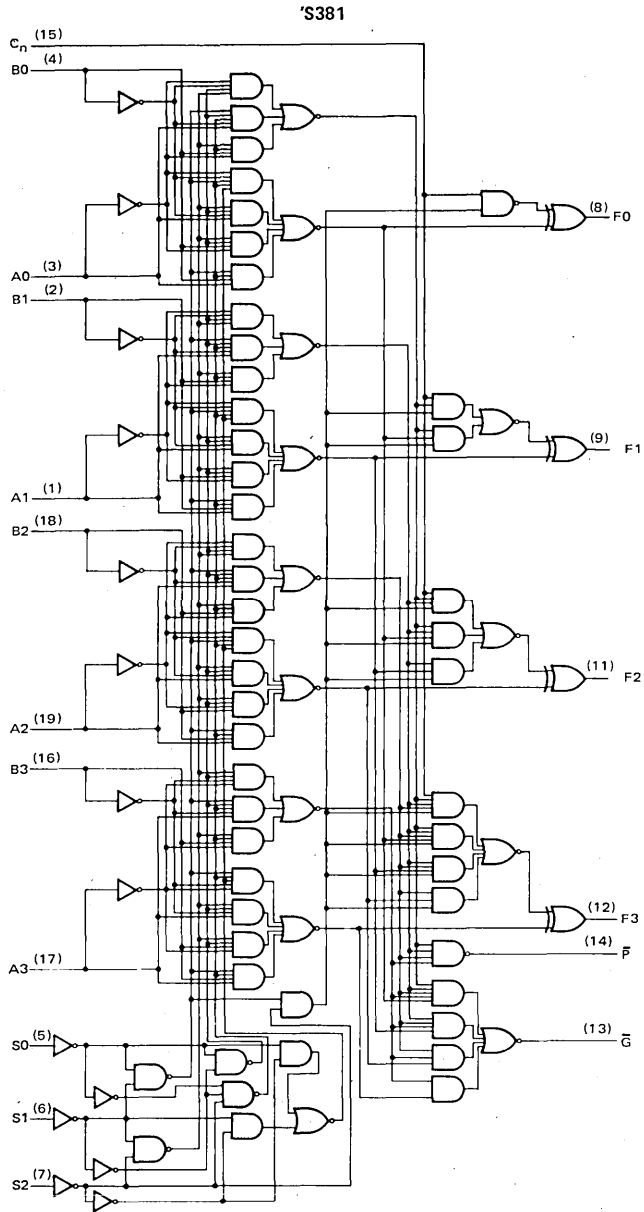

Pin numbers shown on logic notation are for DW, J or N packages.

TYPES SN54LS381A, SN54LS382, SN54S381, SN74LS381A, SN74LS382, SN74S381 ARITHMETIC LOGIC UNITS/FUNCTION GENERATORS

logic symbols

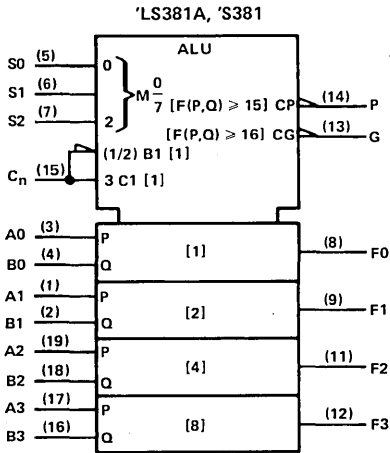

Pin numbers shown on logic notation are for DW, J or N packages.

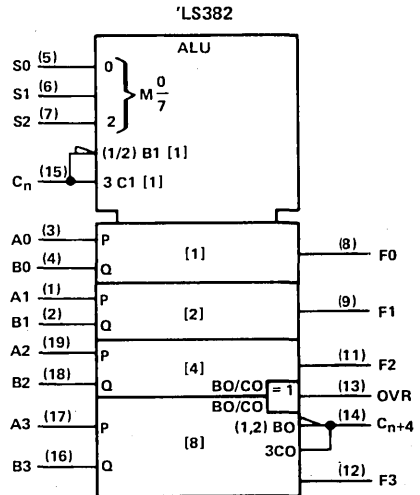

schematics of inputs and outputs

'LS381, 'LS382

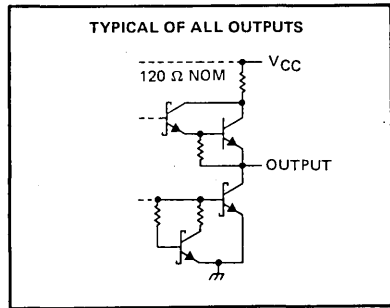
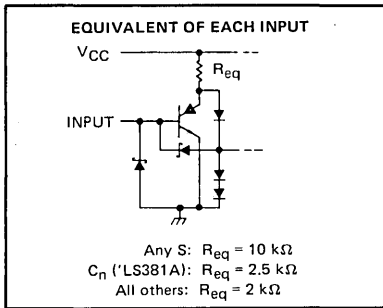

'S381

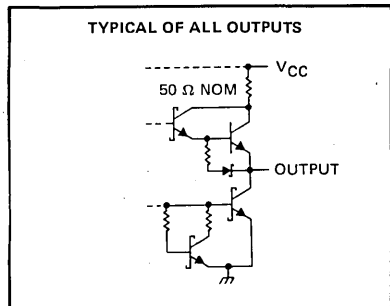
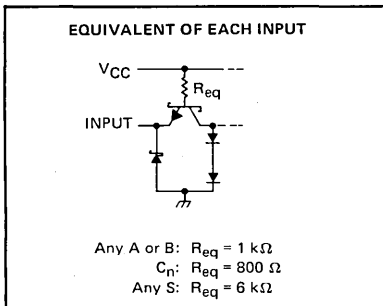

3

TTL DEVICES

TYPES SN54LS381A, SN54LS382, SN74LS381A, SN74LS382

ARITHMETIC LOGIC UNITS/FUNCTION GENERATORS

absolute maximum ratings over operating free-air temperature range (unless otherwise noted)

Supply voltage, V_{CC} (see Note 1)	7 V
Input voltage	7 V
Operating free-air temperature range: SN54LS381A, SN54LS382	-55°C to 125°C
SN74LS381A, SN74LS382	0°C to 70°C
Storage temperature range	-65°C to 150°C

NOTE 1: Voltage values are with respect to the network ground terminal.

recommended operating conditions

	SN54LS'			SN74LS'			UNIT
	MIN	NOM	MAX	MIN	NOM	MAX	
V_{CC} Supply voltage	4.5	5	5.5	4.75	5	5.25	V
V_{IH} High-level input voltage	2			2			V
V_{IL} Low-level input voltage	0.7			0.8			V
I_{OH} High-level output current	-0.4			-0.4			mA
I_{OL} Low-level output current	\bar{G} output of 'LS381A			16			mA
	All other outputs			4			
T_A Operating free-air temperature	-55	125		0	70		°C

electrical characteristics over recommended operating free-air temperature range (unless otherwise noted)

PARAMETER	TEST CONDITIONS†	SN54LS'		SN74LS'		UNIT
		MIN	TYP‡	MAX	MIN	
V_{IK}	$V_{CC} = \text{MIN}, I_I = -18 \text{ mA}$	-1.5		-1.5		V
V_{OH}	$V_{CC} = \text{MIN}, V_{IH} = 2 \text{ V}, V_{IL} = \text{MAX}, I_{OH} = -0.4 \text{ mA}$	2.5	3.4	2.7	3.4	V
V_{OL}	\bar{G} ('LS381A)	$V_{CC} = \text{MIN}, V_{IH} = 2 \text{ V}, I_{OL} = 16 \text{ mA}$		0.47	0.7	V
	Other outputs	$V_{IL} = \text{MAX}, I_{OL} = 4 \text{ mA}$		0.25	0.4	
		$I_{OL} = 8 \text{ mA}$		0.35 0.5		
I_I	$V_{CC} = \text{MAX}, V_I = 7 \text{ V}$	0.1		0.1		mA
I_{IH}	Any S	20		20		μA
	Any A or B	100		100		
	C_n ('LS381A)	80		80		
	C_n ('LS382)	100		100		
I_{IL}	Any S	-0.2		-0.2		mA
	Any A or B	-1		-1		
	C_n ('LS381A)	-0.8		-0.8		
	C_n ('LS382)	-0.8		-0.8		
$I_{OS}§$	$V_{CC} = \text{MAX}$	-20	-100	-20	-100	mA
I_{CC}	$V_{CC} = \text{MAX},$ All inputs grounded, outputs open	35 65		35 65		mA

† For conditions shown as MIN or MAX, use the appropriate value specified under recommended operating conditions.

‡ All typical values are at $V_{CC} = 5 \text{ V}, T_A = 25^\circ\text{C}$.

§ Not more than one output should be shorted at a time, and duration of the short circuit should not exceed one second.

TYPES SN54LS381A, SN54LS382, SN74LS381A, SN74LS382
ARITHMETIC LOGIC UNITS/FUNCTION GENERATORS

switching characteristics, $V_{CC} = 5\text{ V}$, $T_A = 25^\circ\text{C}$ (see note 3)

PARAMETER	FROM (INPUT)	TO (OUTPUT)	TEST CONDITIONS	'LS381A			'LS382			UNIT
				MIN	TYP	MAX	MIN	TYP	MAX	
t_{PLH}	C_n	Any F	$R_L = 2\text{ k}\Omega$, $C_L = 15\text{ pF}$	18	27		18	27	ns	
t_{PHL}				14	21		14	21		
t_{PLH}	Any A or B	\bar{G}		20	30				ns	
t_{PHL}				21	33					
t_{PLH}	Any A or B	\bar{P}		21	33				ns	
t_{PHL}				23	33					
t_{PLH}	A_i or B_j	F_i		20	30		20	30	ns	
t_{PHL}				15	23		15	23		
t_{PLH}	S0, S1, S2	F_i		35	53		35	53	ns	
t_{PHL}				34	51		34	51		
t_{PLH}	S0, S1, S2	\bar{G} or \bar{P}		31	47				ns	
t_{PHL}				32	48					
t_{PLH}	Any A or B	C_{n+4}					28	42	ns	
t_{PHL}							26	39		
t_{PLH}	Any A or B	OVR					23	35	ns	
t_{PHL}							27	41		
t_{PLH}	S0, S1, S2	C_{n+4} or OVR					38	57	ns	
t_{PHL}							36	54		
t_{PLH}	C_n	OVR					10	15	ns	
t_{PHL}							13	23		
t_{PLH}	C_n	C_{n+4}				13	21	ns		
t_{PHL}						11	20			

NOTE 3: See General Information Section for load circuits and voltage waveforms.

3

TTL DEVICES

TYPES SN54S381, SN74S381 ARITHMETIC LOGIC UNIT/FUNCTION GENERATORS

absolute maximum ratings over operating free-air temperature range (unless otherwise noted)

Supply voltage, V_{CC} (see Note 1)	7 V
Input voltage	5.5 V
Interemitter voltage (see Note 2)	5.5 V
Operating free-air temperature range: SN54S381	-55°C to 125°C
SN74S381	0°C to 70°C
Storage free-air temperature range	-65°C to 150°C

NOTES: 1. Voltage values, except interemitter voltage, are with respect to network ground terminal.
2. This is the voltage between two emitters of a multiple-emitter transistor. For this circuit, this rating applies to each A input in conjunction with its respective B input; for example A0 with B0, etc.

recommended operating conditions

	SN54S381			SN74S381			UNIT
	MIN	NOM	MAX	MIN	NOM	MAX	
Supply voltage, V_{CC}	4.5	5	5.5	4.75	5	5.25	V
High-level output current, I_{OH}			-1			-1	mA
Low-level output current, I_{OL}			20			20	mA
Operating free-air temperature, T_A	-55		125	0		70	°C

electrical characteristics over recommended operating free-air temperature range (unless otherwise noted)

PARAMETER			TEST CONDITIONS†		MIN	TYP‡	MAX	UNIT	
V_{IH}	High-level input voltage					2			V
V_{IL}	Low-level input voltage						0.8	V	
V_{IK}	Input clamp voltage		$V_{CC} = \text{MIN}$, $I_I = -18 \text{ mA}$				-1.2	V	
V_{OH}	High-level output voltage	SN54S381	$V_{CC} = \text{MIN}$, $V_{IH} = 2 \text{ V}$, $V_{IL} = 0.8 \text{ V}$, $I_{OH} = -1 \text{ mA}$	2.4	3.4			V	
		SN74S381		2.7	3.4				
V_{OL}	Low-level output voltage		$V_{CC} = \text{MIN}$, $V_{IH} = 2 \text{ V}$, $V_{IL} = 0.8 \text{ V}$, $I_{OL} = 20 \text{ mA}$				0.5	V	
I_I	Input current at maximum input voltage		$V_{CC} = \text{MAX}$, $V_I = 5.5 \text{ V}$				1	mA	
I_{IH}	High-level input current	Any S input	$V_{CC} = \text{MAX}$, $V_I = 2.7 \text{ V}$				50	μA	
		C_n					250		
		All others					200		
I_{IL}	Low-level input current	Any S input	$V_{CC} = \text{MAX}$, $V_I = 0.5 \text{ V}$				-2	mA	
		C_n					-8		
		All others					-6		
I_{OS}	Short-circuit output current‡		$V_{CC} = \text{MAX}$				-40	-100	mA
I_{CC}	Supply current		$V_{CC} = \text{MAX}$				105	160	mA

† For conditions shown as MIN or MAX, use the appropriate value specified under recommended operating conditions.

‡ All typical values are at $V_{CC} = 5 \text{ V}$, $T_A = 25^\circ\text{C}$.

§ Not more than one output should be shorted at a time.

switching characteristics, $V_{CC} = 5 \text{ V}$, $T_A = 25^\circ\text{C}$

PARAMETER¶	FROM (INPUT)	TO (OUTPUT)	TEST CONDITIONS	MIN	TYP	MAX	UNIT
t_{PLH}	C_n	Any F	$C_L = 15 \text{ pF}$, $R_L = 280 \Omega$, See Note 3		10	17	ns
t_{PHL}					10	17	
t_{PLH}	Any A or B	\bar{G}			12	20	ns
t_{PHL}					12	20	
t_{PLH}	Any A or B	\bar{P}			11	18	ns
t_{PHL}					11	18	
t_{PLH}	A_i or B_i	F_i			18	27	ns
t_{PHL}					16	25	
t_{PLH}	Any S	Any			18	30	ns
t_{PHL}					18	30	

¶ t_{PLH} = propagation delay time, low-to-high-level output

¶ t_{PHL} = propagation delay time, high-to-low-level output

NOTE 3: See General Information Section for load circuits and voltage waveforms.

3 TTL DEVICES

TYPES SN54LS384, SN74LS384 8-BIT BY 1-BIT TWO'S-COMPLEMENT MULTIPLIERS

D2419, JANUARY 1981 — REVISED DECEMBER 1983

- Two's-Complement Multiplication
- Magnitude Only Multiplication
- Cascadable for Any Number of Bits
- 8-Bit Parallel Multiplicand Data Input
- Serial Multiplier Data Input
- Serial Data Output for Multiplication Product
- 40 MHz Typical Maximum Clock Frequency

SN54LS384 ... J PACKAGE
SN74LS384 ... J OR N PACKAGE
(TOP VIEW)

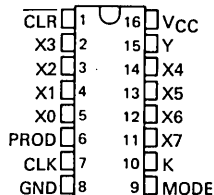

description

The 'LS384 is an 8-bit by 1-bit sequential logic element that performs digital multiplication of two numbers represented in two's-complement form to produce a two's-complement product without external correction by using Booth's algorithm internally. The device accepts an 8-bit multiplicand (X input) and stores this data in eight internal latches. These X latches are controlled via the clear input. When the clear input is low, all internal flip-flops are cleared and the X latches are opened to accept new multiplicand data. When the clear input is high, the latches are closed and are insensitive to X input changes.

The multiplier word data is passed by the Y input in a serial bit stream, least significant bit first. The product is clocked out the PROD output, least significant bit first.

The multiplication of an m-bit multiplicand by an n-bit multiplier results in an (m + n)-bit product. The 'LS384 must be clocked for m + n clock cycles to produce this two's complement product. The n-bit multiplier (Y-input) sign bit data must be extended for the remaining m bits to complete the multiplication cycle.

The device also contains a K input so that devices can be cascaded for longer length X words. The PROD output of one device is connected to the K input of the succeeding device when cascading. The mode input is used to indicate which device contains the most significant bit. The mode input is wired high or low depending on the position of the 8-bit slice in the total X word length. The device with the most significant bit is wired low and all lower order bit packages are wired high.

The SN54LS384 will be characterized for operation over the full military temperature range from -55°C to 125°C . The SN74LS384 will be characterized for operation from 0°C to 70°C .

SN54LS384 ... FK PACKAGE
SN74LS384 ... FN PACKAGE
(TOP VIEW)

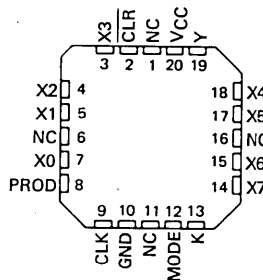

NC - No internal connection

3

TTL DEVICES

PRODUCTION DATA

This document contains information current as of publication date. Products conform to specifications per the terms of Texas Instruments standard warranty. Production processing does not necessarily include testing of all parameters.

TEXAS
INSTRUMENTS

POST OFFICE BOX 225012 • DALLAS, TEXAS 75265

3-1045

TYPES SN54LS384, SN74LS384 8-BIT BY 1-BIT TWO'S-COMPLEMENT MULTIPLIERS

FUNCTION TABLE

INPUTS				INTERNAL Y ₋₁	OUTPUT PROD	FUNCTION
CLR	CLK	X _i	Y			
L	X	Data	X	L	L	Load new multiplicand and clear internal sum and carry registers
H	↑	X	L	L	Output	Shift sum register
H	↑	X	L	H	H	Add multiplicand to sum register and shift
H	↑	X	H	L	H	Booth's algorithm
H	↑	X	H	H	H	Subtract multiplicand from sum register and shift
H	↑	X	H	H	H	Shift sum register

H = high-level, L = low-level, X = irrelevant, ↑ = low-to-high-level transition

Schematics of inputs and outputs

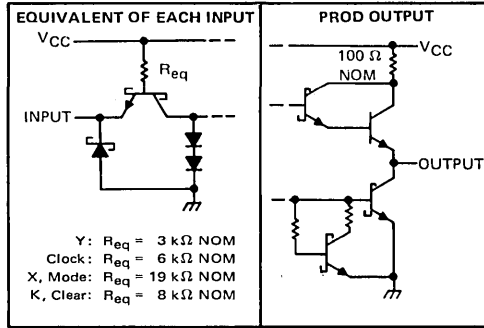

logic symbol

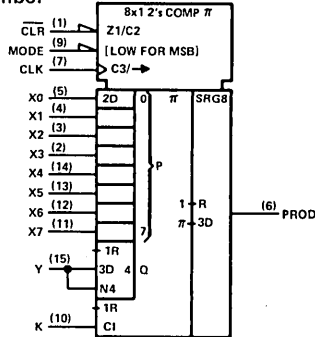

Pin numbers shown on logic notation are for J or N packages.

logic diagram (positive logic)

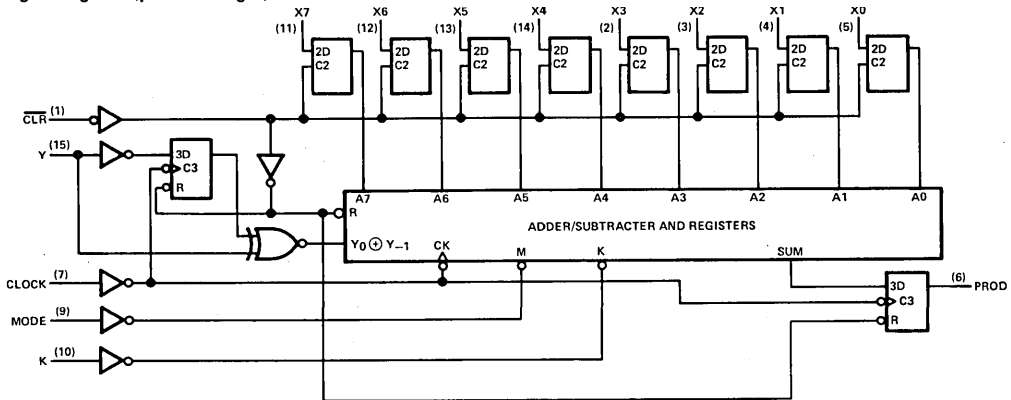

absolute maximum ratings over operating free-air temperature range (unless otherwise noted)

Supply voltage, V _{CC} (see Note 1)	7 V
Input voltage (see Note 2)	5.5 V
Operating free-air temperature range: SN54LS384	-55°C to 125°C
SN74LS384	0°C to 70°C
Storage temperature range	-65°C to 150°C

NOTES: 1. Voltage values are with respect to network ground terminal.

2. Input voltages must be zero or positive with respect to network ground terminal.

TYPES SN54LS384, SN74LS384
8-BIT BY 1-BIT TWO'S-COMPLEMENT MULTIPLIERS

recommended operating conditions

		SN54LS384			SN74LS384			UNIT
		MIN	NOM	MAX	MIN	NOM	MAX	
Supply voltage, V_{CC}		4.5	5	5.5	4.75	5	5.25	V
High-level output current, I_{OH}		-400			-400			μ A
Low-level output current, I_{OL}		4			8			mA
Clock frequency, f_{clock}		0	25		0	25		MHz
Setup time, t_{SU}	Y before Clock \uparrow	45			38			ns
	K before Clock \uparrow	30			24			
	X before Clear \uparrow	23			19			
Clear inactive-state set up time before Clock \uparrow		30			20			
Hold time, t_H	Y after Clock \uparrow	0			0			ns
	K after Clock \uparrow	0			0			
	X after Clear \uparrow	2			2			
Pulse width, t_W	Clock high	20			20			ns
	Clock low	20			20			
	Clear low	38			33			
Operating free-air temperature, T_A		-55	125		0	70		$^{\circ}$ C

electrical characteristics over recommended operating free-air temperature range (unless otherwise noted)

PARAMETER		TEST CONDITIONS [†]	SN54LS384		SN74LS384		UNIT		
			MIN	TYP [‡]	MAX	MIN		TYP [‡]	MAX
V_{IH}	High-level input voltage		2		2		V		
V_{IL}	Low-level input voltage		0.7		0.8		V		
V_{IK}	Input clamp voltage	$V_{CC} = \text{MIN}, I_I = -18 \text{ mA}$	-1.5		-1.5		V		
V_{OH}	High-level output voltage	$V_{CC} = \text{MIN}, V_{IH} = 2 \text{ V}, V_{IL} = V_{IL \text{ max}}, V_{OH} = -400 \mu\text{A}$	2.5	3.4	2.7	3.4	V		
V_{OL}	Low-level output voltage	$V_{CC} = \text{MIN}, V_{IH} = 2 \text{ V}, V_{IL} = V_{IL \text{ max}}$	$I_{OL} = 4 \text{ mA}$ $I_{OL} = 8 \text{ mA}$		0.25	0.4	0.25	0.4	V
I_I	Input current at maximum input voltage	$V_{CC} = \text{MAX}, V_I = 5.5 \text{ V}$	1		1		mA		
I_{IH}	High-level input current	X, Mode	20		20		μ A		
		K, Clear	30		30				
		Clock	40		40				
		Y	80		80				
I_{IL}	Low-level input current	X, Mode	-0.48		-0.48		mA		
		K, Clear	-1.2		-1.2				
		Clock	-1.6		-1.6				
		Y	-3.2		-3.2				
I_{OS}	Short-circuit output current [§]	$V_{CC} = \text{MAX}$	-20	-100	-20	-100	mA		
I_{CC}	Supply current	$V_{CC} = \text{MAX},$ See Note 3	91	155	91	155	mA		

[†]For conditions shown at MIN or MAX, use the appropriate value specified under recommended operating conditions.

[‡]All typical values are at $V_{CC} = 5 \text{ V}, T_A = 25^{\circ}\text{C}$.

[§]Not more than one output should be shorted at a time, and duration of the short-circuit should not exceed one second.

NOTE 3: I_{CC} is measured with the clear input grounded and all other inputs and outputs open.

switching characteristics, $V_{CC} = 5 \text{ V}, T_A = 25^{\circ}\text{C}$

PARAMETER		TEST CONDITIONS	MIN	TYP	MAX	UNIT
f_{max}	Maximum clock frequency		25	40		MHz
t_{PLH}	Propagation delay time, low-to-high-level output from clock	$C_L = 15 \text{ pF},$		15	23	ns
t_{PHL}	Propagation delay time, high-to-low-level output from clock	$R_L = 2 \text{ k}\Omega,$		15	23	ns
t_{PHL}	Propagation delay time, high-to-low-level output from clear	See Note 4		17	25	ns

NOTE 4: See General Information Section for load circuits and voltage waveforms.

TYPES SN54LS384, SN74LS384
8-BIT BY 1-BIT TWO'S-COMPLEMENT MULTIPLIERS

TYPICAL APPLICATION DATA

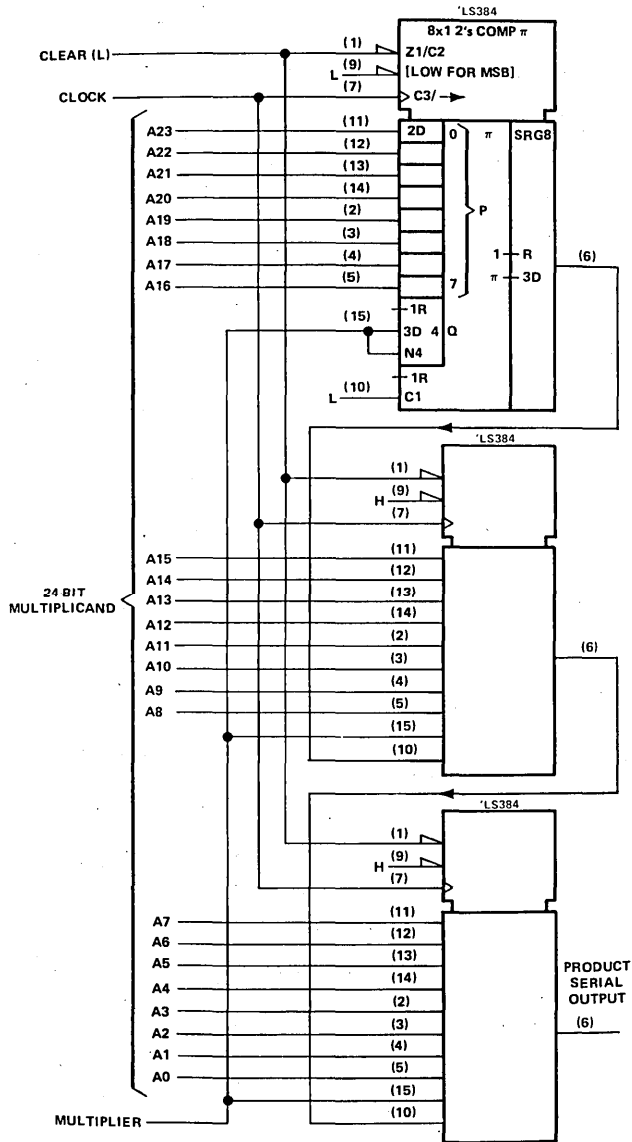

FIGURE 1—BASIC 24-BIT SERIAL/PARALLEL CONNECTION

3

TTL DEVICES

TYPES SN54LS384, SN74LS384 8-BIT BY 1-BIT TWO'S-COMPLEMENT MULTIPLIERS

TYPICAL APPLICATION DATA

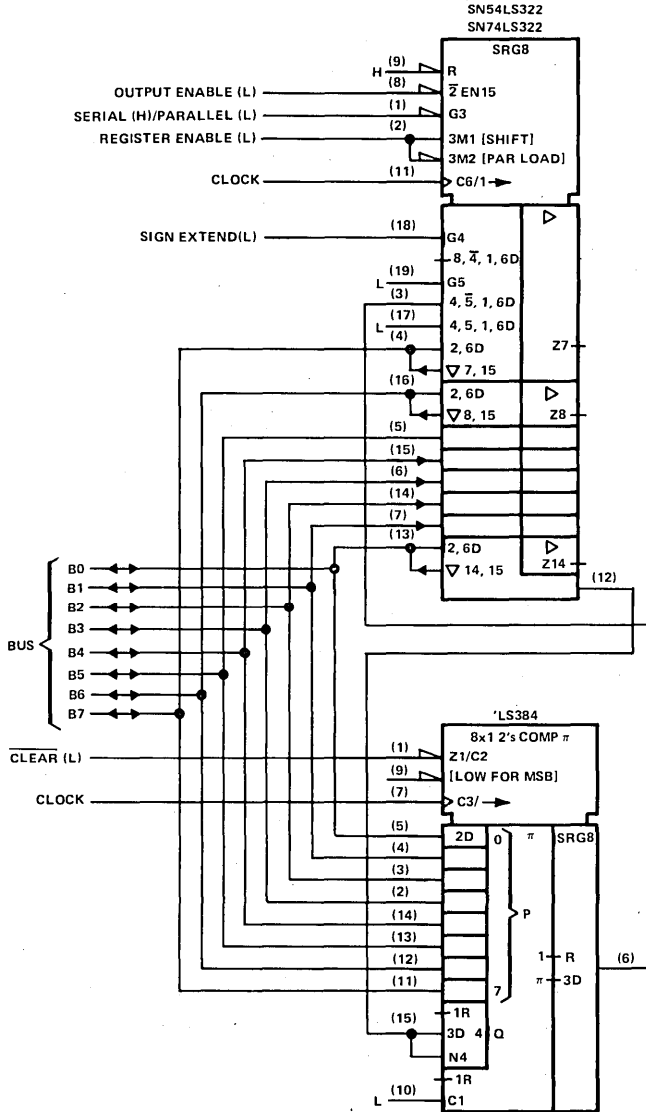

FIGURE 2—8-BIT BY 8-BIT MULTIPLIER, BUS ORGANIZED,
WITH 8-BIT TRUNCATED PRODUCT

3
TTL DEVICES

TYPES SN54LS385, SN74LS385 QUADRUPLE SERIAL ADDERS/SUBTRACTORS

D2412, NOVEMBER 1977—REVISED APRIL 1985

- Four Synchronous Elements in a Single 20-Pin Package
- Buffered Clock and Direct Clear Inputs
- Independent Two's-Complement Addition/Subtraction

description

The 'LS385 is a general purpose adder/subtractor and is particularly useful as a companion part to the SN54LS384/SN74LS384 serial/parallel two's-complement multiplier. The 'LS385 contains four independent adder/subtractor elements with common clock and clear.

Each of the four independent sum (Σ) outputs reflects its respective A and B input as controlled by the S/ \bar{A} control. When S/ \bar{A} is high the Σ function is A minus B. When S/ \bar{A} is low the Σ function is A plus B.

When low, the clear input asynchronously resets the sum flip-flop low and the carry flip-flop either high in the subtract mode or low in the add mode. The clock is positive-edge triggered and controls the sum and carry flip-flops according to the function table.

SN54LS385 ... J PACKAGE
SN74LS385 ... DW, J OR N PACKAGE
(TOP VIEW)

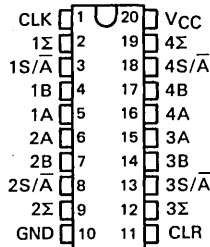

SN54LS385 ... FK PACKAGE
SN74LS385 ... FN PACKAGE
(TOP VIEW)

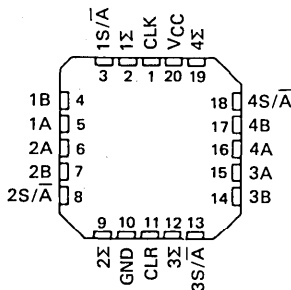

FUNCTION TABLE

SELECTED FUNCTION	INPUTS					DATA IN CARRY FLIP-FLOP		Σ OUTPUT
	CLR	S/ \bar{A}	A	B	CLK	BEFORE ↑	AFTER ↑	AFTER ↑
Clear	L	L	X	X	X	L	L	L
	L	H	X	X	X	H	H	L
Add	H	L	L	L	↑	L	L	L
	H	L	L	L	↑	L	H	H
	H	L	L	H	↑	L	L	H
	H	L	L	H	↑	H	H	H
	H	L	H	L	↑	L	L	H
	H	L	H	L	↑	L	H	L
	H	L	H	H	↑	L	H	L
	H	L	H	H	↑	H	H	H
Subtract	H	H	L	L	↑	L	L	H
	H	H	L	L	↑	H	H	H
	H	H	L	H	↑	L	L	L
	H	H	L	H	↑	L	L	H
	H	H	H	L	↑	L	H	L
	H	H	H	L	↑	H	H	H
	H	H	H	H	↑	L	L	L
	H	H	H	H	↑	H	H	H

H = high level, L = low level, X = irrelevant,

↑ = transition from low to high level at the clock input

PRODUCTION DATA

This document contains information current as of publication date. Products conform to specifications per the terms of Texas Instruments standard warranty. Production processing does not necessarily include testing of all parameters.



POST OFFICE BOX 225012 • DALLAS, TEXAS 75265

TYPES SN54LS385, SN74LS385 QUADRUPLE SERIAL ADDERS/SUBTRACTORS

schematics of inputs and outputs

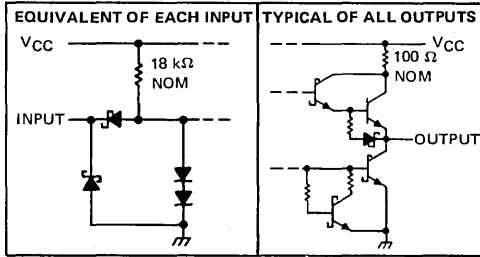

logic symbol

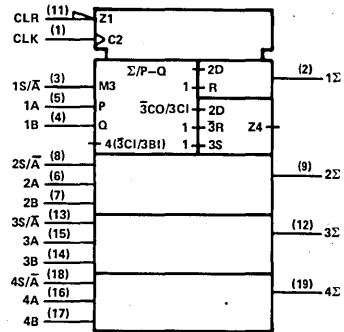

logic diagram (each adder/subtractor, positive logic)

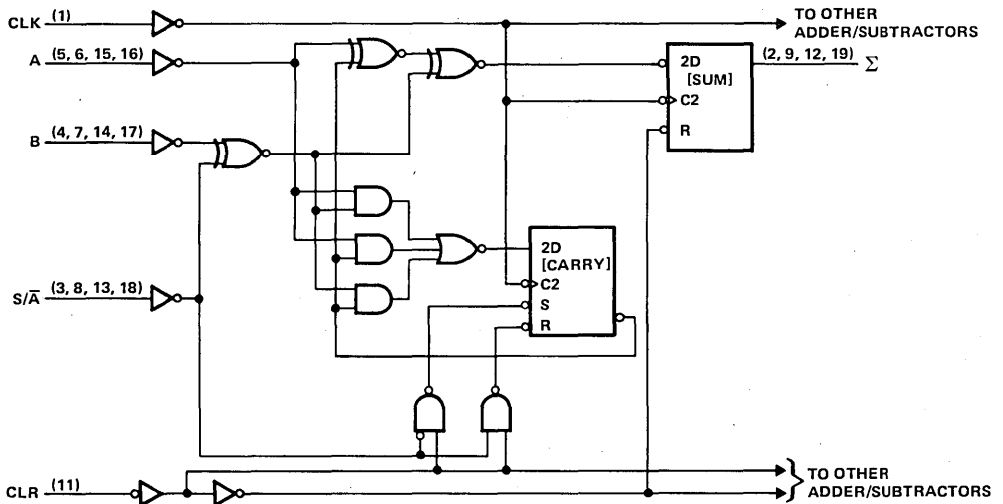

Pin numbers shown on logic notation are for DW, J or N packages.

TYPES SN54LS385, SN74LS385 QUADRUPLE SERIAL ADDERS/SUBTRACTORS

recommended operating conditions

	SN54LS385			SN74LS385			UNIT
	MIN	NOM	MAX	MIN	NOM	MAX	
Supply voltage, V_{CC} (see Note 1)	4.5	5	5.5	4.75	5	5.25	V
High-level output current, I_{OH}			-400			-400	μ A
Low-level output current, I_{OL}			4			8	mA
Clock frequency, f_{clock}	0		30	0		30	MHz
Width of clock pulse, t_w	16			16			ns
Setup time, t_{su}	10			10			ns
Hold time, t_h	3			3			ns
Operating free-air temperature, T_A	-55		125	0		70	$^{\circ}$ C

NOTE 1: Voltage values are with respect to network ground terminal.

electrical characteristics over recommended operating free-air temperature range (unless otherwise noted)

PARAMETER	TEST CONDITIONS†	SN54LS385		SN74LS385		UNIT		
		MIN	TYP‡	MAX	MIN		TYP‡	MAX
V_{IH} High-level input voltage		2		2		V		
V_{IL} Low-level input voltage				0.7		0.8	V	
V_{IK} Input clamp voltage	$V_{CC} = \text{MIN}, I_I = -18 \text{ mA}$			-1.5		-1.5	V	
V_{OH} High-level output voltage	$V_{CC} = \text{MIN}, V_{IH} = 2 \text{ V}, V_{IL} = V_{ILmax}, I_{OH} = -400 \mu\text{A}$	2.5	3.5	2.7	3.5	V		
V_{OL} Low-level output voltage	$V_{CC} = \text{MIN}, V_{IH} = 2 \text{ V}, V_{IL} = V_{ILmax}$			0.25	0.4	0.25	0.4	V
						0.35	0.5	V
I_I Input current at maximum input voltage	$V_{CC} = \text{MAX}, V_I = 7 \text{ V}$			0.1		0.1	mA	
I_{IH} High-level input current	$V_{CC} = \text{MAX}, V_I = 2.7 \text{ V}$			20		20	μ A	
I_{IL} Low-level input current	$V_{CC} = \text{MAX}, V_I = 0.4 \text{ V}$			-0.4		-0.4	mA	
I_{OS} Short-circuit output current§	$V_{CC} = \text{MAX}$	-20	-100	-20	-100	mA		
I_{CC} Supply current	$V_{CC} = \text{MAX},$ See Note 2	48	75	48	75	mA		

† For conditions shown as MIN or MAX, use the appropriate value specified under recommended operating conditions.

‡ All typical values are at $V_{CC} = 5 \text{ V}, T_A = 25^{\circ}\text{C}$.

§ Not more than one output should be shorted at a time.

NOTE 2: I_{CC} is measured with all inputs grounded and all outputs open.

switching characteristics, $V_{CC} = 5 \text{ V}, T_A = 25^{\circ}\text{C}$

PARAMETER [◇]	FROM (INPUT)	TO (OUTPUT)	TEST CONDITIONS	MIN	TYP	MAX	UNIT
f_{max}				30	40		MHz
t_{PLH}	Clock	Σ	$C_L = 15 \text{ pF}, R_L = 2 \text{ k}\Omega,$ See Note 3		14	22	ns
t_{PHL}					18	27	
t_{PHL}	Clear	Σ			18	30	ns
t_{PHL}							

[◇] f_{max} \equiv maximum clock frequency

t_{PLH} \equiv propagation delay time, low-to-high-level output

t_{PHL} \equiv propagation delay time, high-to-low-level output

NOTE 3: See General Information Section for load circuits and voltage waveforms.

3

TTL DEVICES

TYPES SN54LS386A, SN74LS386A QUADRUPLE 2-INPUT EXCLUSIVE-OR GATES

MARCH 1974—REVISED DECEMBER 1983

- Electrically Identical to SN54LS86A/SN74LS86A
- Mechanically Identical to SN54L86/SN74L86
- Total Average Propagation Delay Times . . . 10 ns
- Typical Total Power Dissipation . . . 30.5 mW

FUNCTION TABLE
(EACH GATE)

INPUTS		OUTPUT
A	B	
L	L	L
L	H	H
H	L	H
H	H	L

H = high level
L = low level

logic diagram (each gate)



positive logic

$$Y = A \oplus B = \bar{A}B + A\bar{B}$$

schematics of inputs and outputs

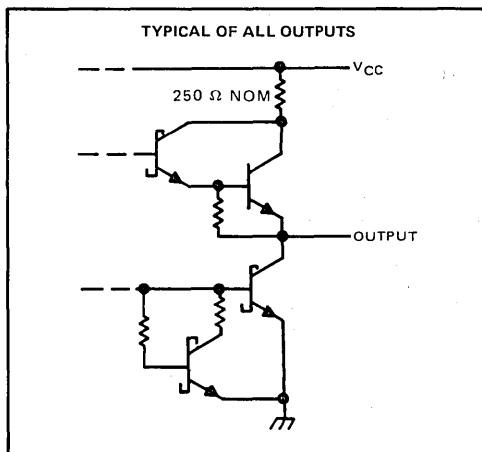
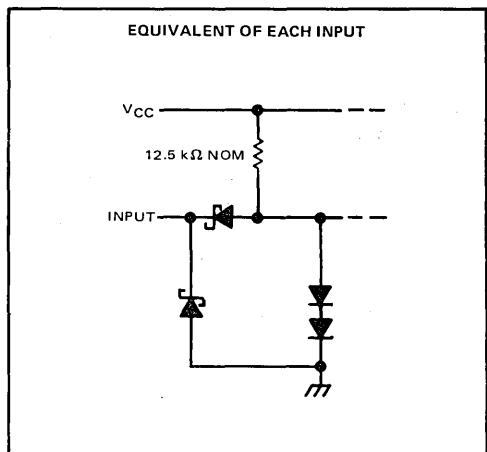

SN54LS386A . . . J OR W PACKAGE
SN74LS386A . . . D, J OR N PACKAGE
(TOP VIEW)

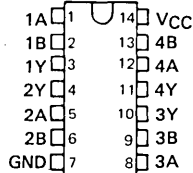

SN54LS386A . . . FK PACKAGE
SN74LS386A . . . FN PACKAGE
(TOP VIEW)

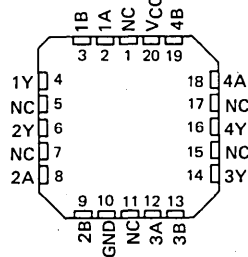

NC - No internal connection

PRODUCTION DATA
This document contains information current as of publication date. Products conform to specifications per the terms of Texas Instruments standard warranty. Production processing does not necessarily include testing of all parameters.

**TEXAS
INSTRUMENTS**

POST OFFICE BOX 225012 • DALLAS, TEXAS 75265

3-1053

3
TTL DEVICES

TYPES SN54LS386A, SN74LS386A QUADRUPLE 2-INPUT EXCLUSIVE-OR GATES

absolute maximum ratings over operating free-air temperature range (unless otherwise noted)

Supply voltage, V_{CC} (see Note 1)	7 V
Input voltage	7 V
Operating free-air temperature range: SN54LS386A	-55°C to 125°C
SN74LS386A	0°C to 70°C
Storage temperature range	-65°C to 150°C

NOTE 1: Voltage values are with respect to network ground terminal.

recommended operating conditions

	SN54LS386A			SN74LS386A			UNIT
	MIN	NOM	MAX	MIN	NOM	MAX	
Supply voltage, V_{CC}	4.5	5	5.5	4.75	5	5.25	V
High-level output current, I_{OH}			-400			-400	μ A
Low-level output current, I_{OL}			4			8	mA
Operating free-air temperature, T_A	-55		125	0		70	°C

electrical characteristics over recommended operating free-air temperature range (unless otherwise noted)

PARAMETER	TEST CONDITIONS†	SN54LS386A			SN74LS386A			UNIT	
		MIN	TYP‡	MAX	MIN	TYP‡	MAX		
V_{IH} High-level input voltage		2			2			V	
V_{IL} Low-level input voltage				0.7			0.8	V	
V_{IK} Input clamp voltage	$V_{CC} = \text{MIN}, I_I = -18 \text{ mA}$			-1.5			-1.5	V	
V_{OH} High-level output voltage	$V_{CC} = \text{MIN}, V_{IH} = 2 \text{ V}, V_{IL} = V_{IL \text{ max}}, I_{OH} = -400 \mu\text{A}$	2.5	3.4		2.7	3.4		V	
V_{OL} Low-level output voltage	$V_{CC} = \text{MIN}, V_{IH} = 2 \text{ V}, V_{IL} = V_{IL \text{ max}}$			0.25	0.4		0.25	0.4	V
	$I_{OL} = 4 \text{ mA}$								
	$I_{OL} = 8 \text{ mA}$						0.35	0.5	
I_I Input current at maximum input voltage	$V_{CC} = \text{MAX}, V_I = 7 \text{ V}$			0.2			0.2	mA	
I_{IH} High-level input current	$V_{CC} = \text{MAX}, V_I = 2.7 \text{ V}$			40			40	μ A	
I_{IL} Low-level input current	$V_{CC} = \text{MAX}, V_I = 0.4 \text{ V}$			-0.8			-0.8	mA	
I_{OS} Short-circuit output current §	$V_{CC} = \text{MAX}$	-20		-100	-20		-100	mA	
I_{CC} Supply current	$V_{CC} = \text{MAX},$ See Note 2			6.1	10		6.1	10	mA

† For conditions shown as MIN or MAX, use the appropriate value specified under recommended operating conditions.

‡ All typical values are at $V_{CC} = 5 \text{ V}, T_A = 25^\circ\text{C}$.

§ Not more than one output should be shorted at a time.

NOTE 2: I_{CC} is measured with the inputs grounded and the outputs open.

switching characteristics, $V_{CC} = 5 \text{ V}, T_A = 25^\circ\text{C}$

PARAMETER¶	FROM (INPUT)	TEST CONDITIONS	MIN	TYP	MAX	UNIT
t_{PLH}	A or B	Other input low	12	23		ns
t_{PHL}						
t_{PLH}	A or B	Other input high	20	30		ns
t_{PHL}						

¶ t_{PLH} = propagation delay time, low-to-high-level output

¶ t_{PHL} = propagation delay time, high-to-low-level output

NOTE 3: See General Information Section for load circuits and voltage waveforms.

3 TTL DEVICES

TYPES SN54390, SN54LS390, SN54393, SN54LS393, SN74390, SN74LS390, SN74393, SN74LS393 DUAL 4-BIT DECADE AND BINARY COUNTERS

OCTOBER 1976—REVISED DECEMBER 1983

- Dual Versions of the Popular '90A, 'LS90 and '93A, 'LS93
- '390, 'LS390 . . . Individual Clocks for A and B Flip-Flops Provide Dual $\div 2$ and $\div 5$ Counters
- '393, 'LS393 . . . Dual 4-Bit Binary Counter with Individual Clocks
- All Have Direct Clear for Each 4-Bit Counter
- Dual 4-Bit Versions Can Significantly Improve System Densities by Reducing Counter Package Count by 50%
- Typical Maximum Count Frequency . . . 35 MHz
- Buffered Outputs Reduce Possibility of Collector Commutation

description

Each of these monolithic circuits contains eight master-slave flip-flops and additional gating to implement two individual four-bit counters in a single package. The '390 and 'LS390 incorporate dual divide-by-two and divide-by-five counters, which can be used to implement cycle lengths equal to any whole and/or cumulative multiples of 2 and/or 5 up to divide-by-100. When connected as a bi-quinary counter, the separate divide-by-two circuit can be used to provide symmetry (a square wave) at the final output stage. The '393 and 'LS393 each comprise two independent four-bit binary counters each having a clear and a clock input. N-bit binary counters can be implemented with each package providing the capability of divide-by-256. The '390, 'LS390, '393, and 'LS393 have parallel outputs from each counter stage so that any submultiple of the input count frequency is available for system-timing signals.

Series 54 and Series 54LS circuits are characterized for operation over the full military temperature range of -55°C to 125°C ; Series 74 and Series 74LS circuits are characterized for operation from 0°C to 70°C .

SN54390, SN54LS390 . . . J OR W PACKAGE
SN74390 . . . J OR N PACKAGE
SN74LS390 . . . D, J OR N PACKAGE

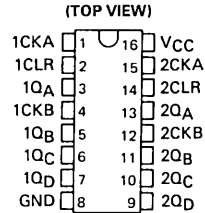

SN54LS390 . . . FK PACKAGE
SN74LS390 . . . FN PACKAGE

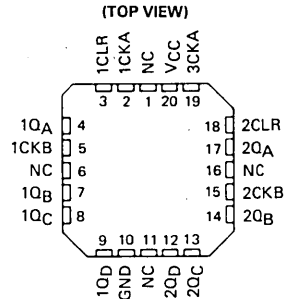

SN54393, SN54LS393 . . . J OR W PACKAGE
SN74393 . . . J OR N PACKAGE
SN74LS393 . . . D, J OR N PACKAGE

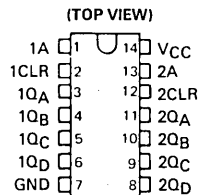

SN54LS393 . . . FK PACKAGE
SN74LS393 . . . FN PACKAGE

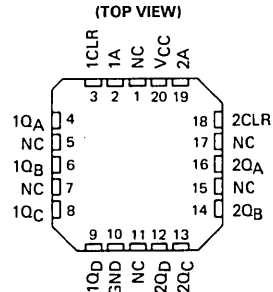

NC - No internal connection

PRODUCTION DATA
This document contains information current as of publication date. Products conform to specifications per the terms of Texas Instruments standard warranty. Production processing does not necessarily include testing of all parameters.

**TEXAS
INSTRUMENTS**

POST OFFICE BOX 225012 • DALLAS, TEXAS 75265

TYPES SN54390, SN54LS390, SN54393, SN54LS393, SN74390, SN74LS390, SN74393, SN74LS393 DUAL 4-BIT DECADE AND BINARY COUNTERS

logic diagrams (continued)

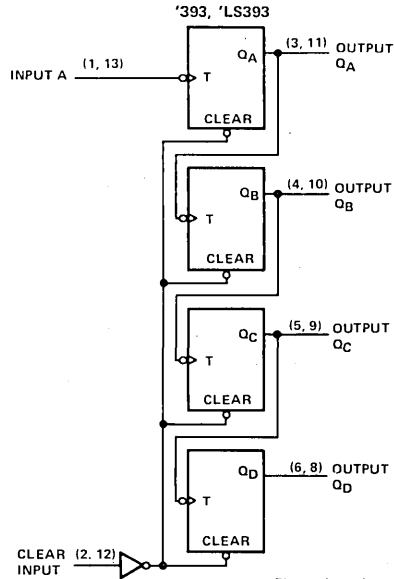

Pin numbers shown on logic notation are for D, J or N packages.

schematics of inputs and outputs

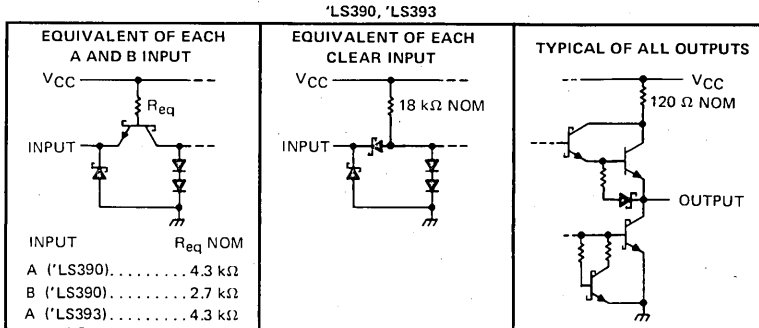
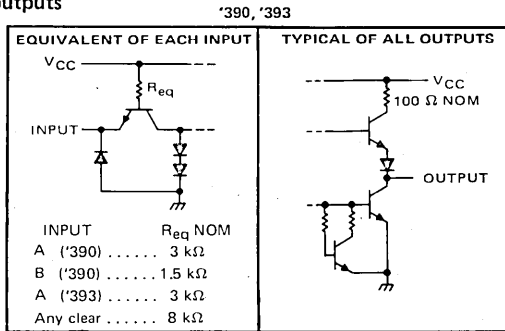

3
TTL DEVICES

TYPES SN54390, SN54393, SN74390, SN74393 DUAL 4-BIT DECADE AND BINARY COUNTERS

absolute maximum ratings over operating free-air temperature range (unless otherwise noted)

Supply voltage, V_{CC} (see Note 1)	7 V
Input voltage	5.5 V
Operating free-air temperature range: SN54390, SN54393	-55°C to 125°C
SN74390, SN74393	0°C to 70°C
Storage temperature range	-65°C to 150°C

NOTE 1: Voltage values are with respect to network ground terminal.

recommended operating conditions

	SN54390 SN54393			SN74390 SN74393			UNIT
	MIN	NOM	MAX	MIN	NOM	MAX	
Supply voltage, V_{CC}	4.5	5	5.5	4.75	5	5.25	V
High-level output current, I_{OH}				-800			μ A
Low-level output current, I_{OL}				16			mA
Count frequency, f_{count}	A input	0	25	0	25		MHz
	B input	0	20	0	20		
Pulse width, t_w	A input high or low	20		20			ns
	B input high or low	25		25			
	Clear high	20		20			
Clear inactive-state setup time, t_{su}	25 \downarrow			25 \downarrow			ns
Operating free-air temperature, T_A	-55		125	0		70	°C

\downarrow The arrow indicates that the falling edge of the clock pulse is used for reference.

electrical characteristics over recommended operating free-air temperature range (unless otherwise noted)

PARAMETER	TEST CONDITIONS [†]	'390			'393			UNIT
		MIN	TYP [‡]	MAX	MIN	TYP [‡]	MAX	
V_{IH} High-level input voltage		2			2			V
V_{IL} Low-level input voltage		0.8			0.8			V
V_{IK} Input clamp voltage	$V_{CC} = \text{MIN}, I_I = -12 \text{ mA}$	-1.5			-1.5			V
V_{OH} High-level output voltage	$V_{CC} = \text{MIN}, V_{IH} = 2 \text{ V}, V_{IL} = 0.8 \text{ V}, I_{OH} = -800 \mu\text{A}$	2.4	3.4		2.4	3.4		V
V_{OL} Low-level output voltage	$V_{CC} = \text{MIN}, V_{IH} = 2 \text{ V}, V_{IL} = 0.8 \text{ V}, I_{OL} = 16 \text{ mA}^{\S}$	0.2	0.4		0.2	0.4		V
I_I Input current at maximum input voltage	$V_{CC} = \text{MAX}, V_I = 5.5 \text{ V}$	1			1			mA
I_{IH} High-level input current	Clear	40			40			μ A
	Input A	80			80			
	Input B	120			120			
I_{IL} Low-level input current	Clear	-1			-1			mA
	Input A	-3.2			-3.2			
	Input B	-4.8			-4.8			
I_{OS} Short-circuit output current [§]	$V_{CC} = \text{MAX}$	SN54 [¶]	-20	-57	-20	-57	mA	
		SN74 [¶]	-18	-57	-18	-57		
I_{CC} Supply current	$V_{CC} = \text{MAX},$ See Note 2	42	69		38	64	mA	

[†] For conditions shown as MIN or MAX, use the appropriate value specified under recommended operating conditions.

[‡] All typical values are at $V_{CC} = 5 \text{ V}, T_A = 25^\circ\text{C}$.

[§] The I_{OL} outputs of the '390 are tested at $I_{OL} = 16 \text{ mA}$ plus the limit value for I_{IL} for the B input. This permits driving the B input while maintaining full fan-out capability.

[¶] Not more than one output should be shorted at a time.

NOTE 2: I_{CC} is measured with all outputs open, both clear inputs grounded following momentary connection to 4.5 V, and all other inputs grounded.

TYPES SN54390, SN54393, SN74390, SN74393
 DUAL 4-BIT DECADE AND BINARY COUNTERS

switching characteristics, $V_{CC} = 5\text{ V}$, $T_A = 25^\circ\text{C}$

PARAMETER [†]	FROM (INPUT)	TO (OUTPUT)	TEST CONDITIONS	'390			'393			UNIT
				MIN	TYP	MAX	MIN	TYP	MAX	
f_{max}	A	Q_A	$C_L = 15\text{ pF}$, $R_L = 400\ \Omega$, See Note 3 and Figure 1	25	35		25	35	MHz	
	B	Q_B		20	30					
t_{PLH}	A	Q_A		12	20		12	20	ns	
t_{PHL}				13	20		13	20		
t_{PLH}	A	Q_C of '390 Q_D of '393		37	60		40	60	ns	
t_{PHL}				39	60		40	60		
t_{PLH}	B	Q_B		13	21				ns	
t_{PHL}				14	21					
t_{PLH}	B	Q_C		24	39				ns	
t_{PHL}				26	39					
t_{PLH}	B	Q_D		13	21				ns	
t_{PHL}				14	21					
t_{PHL}	Clear	Any		24	39		24	39	ns	

[†] f_{max} \equiv maximum count frequency

t_{PLH} \equiv propagation delay time, low-to-high-level output

t_{PHL} \equiv propagation delay time, high-to-low-level output

NOTE 3: See General Information Section for load circuits and voltage waveforms.

PARAMETER MEASUREMENT INFORMATION

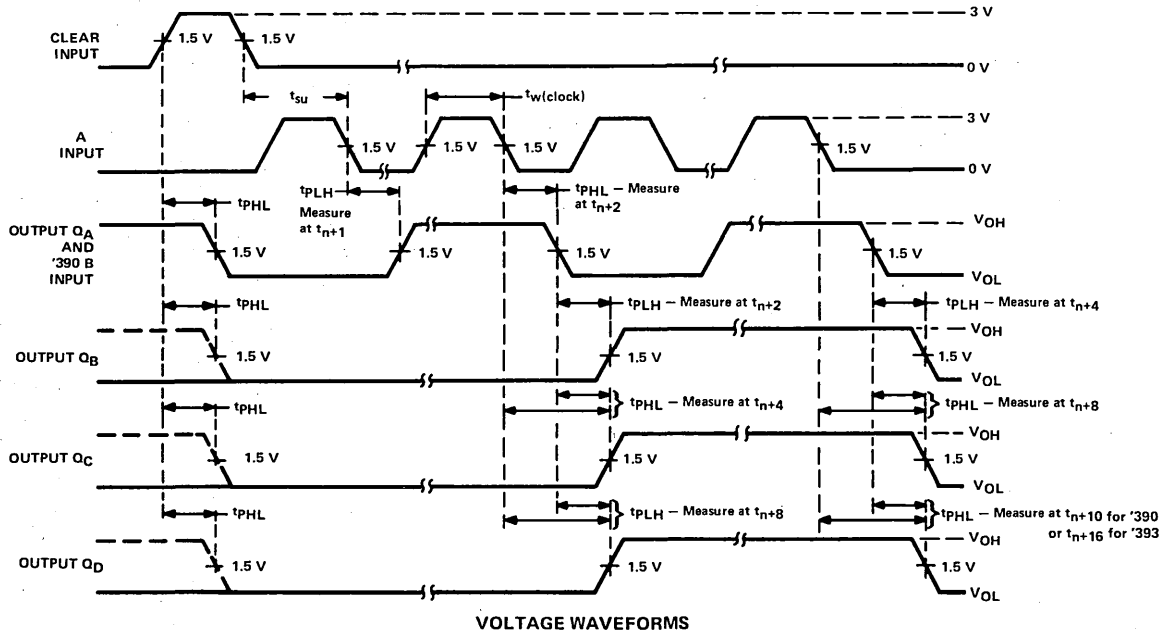

NOTE A: Input pulses are supplied by a generator having the following characteristics $t_r < 5$ ns, $t_f < 5$ ns, PRR = 1 MHz, duty cycle = 50%, $Z_{out} \approx 50$ ohms.

FIGURE 1

TYPES SN54LS390, SN54LS393, SN74LS390, SN74LS393

DUAL 4-BIT DECADE AND BINARY COUNTERS

absolute maximum ratings over operating free-air temperature range (unless otherwise noted)

Supply voltage, V_{CC} (see Note 1)	7 V
Clear input voltage	7 V
Any A or B clock input voltage	5.5 V
Operating free-air temperature range: SN54LS390, SN54LS393	-55°C to 125°C
SN74LS390, SN74LS393	0°C to 70°C
Storage temperature range	-65°C to 150°C

NOTE 1: Voltage values are with respect to network ground terminal.

recommended operating conditions

		SN54LS390 SN54LS393			SN74LS390 SN74LS393			UNIT		
		MIN	NOM	MAX	MIN	NOM	MAX			
Supply voltage, V_{CC}		4.5	5	5.5	4.75	5	5.25	V		
High-level output current, I_{OH}		-400			-400			μ A		
Low-level output current, I_{OL}		4			8			mA		
Count frequency, f_{count}	A input	0		25	0		25	MHz		
	B input	0		12.5	0		12.5			
Pulse width, t_w	A input high or low	20			20			ns		
	B input high or low	40			40					
	Clear high	20			20					
Clear inactive-state setup time, t_{SU}		25↓			25↓			ns		
Operating free-air temperature, T_A		-55			125			0	70	°C

↓ The arrow indicates that the falling edge of the clock pulse is used for reference.

electrical characteristics over recommended operating free-air temperature range (unless otherwise noted)

PARAMETER	TEST CONDITIONS†	SN54LS*		SN74LS*		UNIT
		MIN	TYP‡ MAX	MIN	TYP‡ MAX	
V_{IH} High-level input voltage		2		2		V
V_{IL} Low-level input voltage		0.7		0.8		V
V_{IK} Input clamp voltage	$V_{CC} = \text{MIN}, I_I = -18 \text{ mA}$	-1.5		-1.5		V
V_{OH} High-level output voltage	$V_{CC} = \text{MIN}, V_{IH} = 2 \text{ V}, V_{IL} = V_{ILmax}, V_{OH} = -400 \mu\text{A}$	2.5	3.4	2.7	3.4	V
V_{OL} Low-level output voltage	$V_{CC} = \text{MIN}, V_{IH} = 2 \text{ V}, V_{IL} = 0.8 \text{ V}, I_{OL} = 4 \text{ mA}^\S, I_{OL} = 8 \text{ mA}^\S$	0.25	0.4	0.25	0.4	V
I_I Input current at maximum input voltage	Clear	0.1		0.1		mA
	Input A	0.2		0.2		
	Input B	0.4		0.4		
I_{IH} High-level input current	Clear	0.02		0.02		mA
	Input A	0.1		0.1		
I_{IL} Low-level input current	Input B	0.2		0.2		mA
	Clear	-0.4		-0.4		
I_{OS} Short-circuit output current [§]	Input A	-1.6		-1.6		mA
	Input B	-2.4		-2.4		
I_{CC} Supply current	Clear	-20		-20		mA
	$V_{CC} = \text{MAX}$	-100		-100		
	See Note 2	*LS390		*LS393		mA
		15	26	15	26	

† For conditions shown as MIN or MAX, use the appropriate value specified under recommended operating conditions.

‡ All typical values are at $V_{CC} = 5 \text{ V}, T_A = 25^\circ\text{C}$.

§ The Q_A outputs of the *LS390 are tested at $I_{OL} = \text{MAX}$ plus the limit value for I_{IL} for the clock B input. This permits driving the clock B input while maintaining full fan-out capability.

¶ Not more than one output should be shorted at a time, and duration of the short-circuit should not exceed one second.

NOTE 2: I_{CC} is measured with all outputs open, both clear inputs grounded following momentary connection to 4.5 V, and all other inputs grounded.



POST OFFICE BOX 225012 • DALLAS, TEXAS 75265

3-1061

3

TTL DEVICES

TYPES SN54LS390, SN54LS393, SN74LS390, SN74LS393
DUAL 4-BIT DECADE AND BINARY COUNTERS

switching characteristics, $V_{CC} = 5\text{ V}$, $T_A = 25^\circ\text{ C}$

PARAMETER [†]	FROM (INPUT)	TO (OUTPUT)	TEST CONDITIONS	'LS390			'LS393			UNIT
				MIN	TYP	MAX	MIN	TYP	MAX	
f_{max}	A	Q_A	$C_L = 15\text{ pF}$, $R_L = 2\text{ k}\Omega$, See Note 4 and Figure 2	25	35		25	35		MHz
	B	Q_B		12.5	20					
t_{PLH}	A	Q_A		12	20		12	20		ns
t_{PHL}				13	20		13	20		
t_{PLH}	A	Q_C of 'LS390		37	60		40	60		ns
t_{PHL}		Q_D of 'LS393		39	60		40	60		
t_{PLH}	B	Q_B		13	21					ns
t_{PHL}				14	21					
t_{PLH}	B	Q_C		24	39					ns
t_{PHL}				26	39					
t_{PLH}	B	Q_D		13	21					ns
t_{PHL}				14	21					
t_{PHL}	Clear	Any		24	39		24	39		ns

[†] f_{max} ≡ maximum count frequency
 t_{PLH} ≡ propagation delay time, low-to-high-level output
 t_{PHL} ≡ propagation delay time, high-to-low-level output

NOTE 4: See General Information Section for load circuits and voltage waveforms.

PARAMETER MEASUREMENT INFORMATION

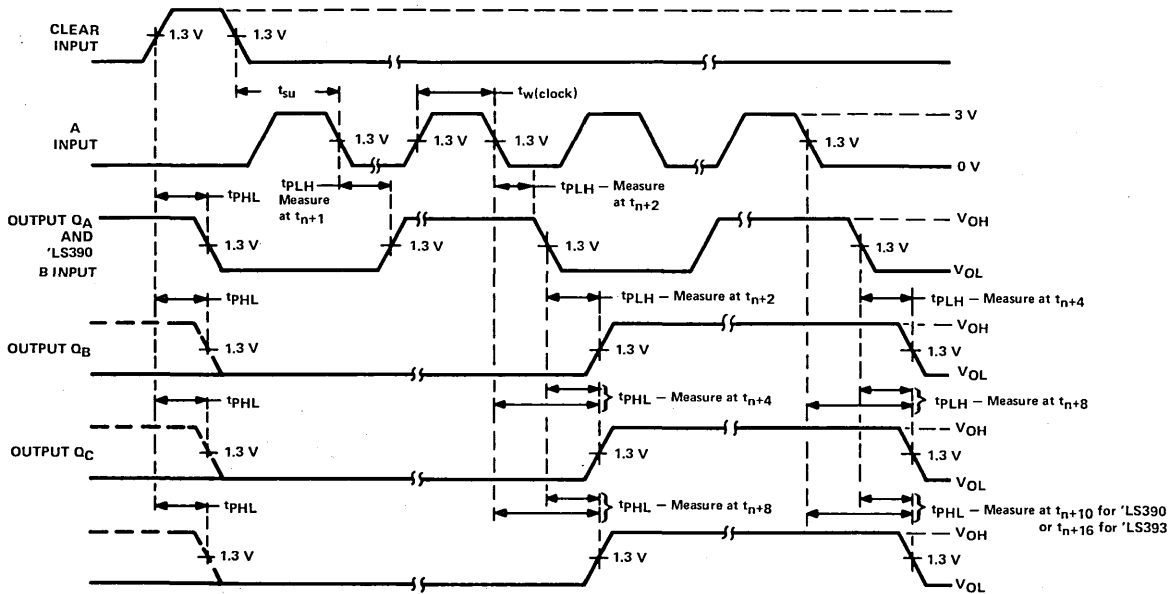

VOLTAGE WAVEFORMS

NOTE A: Input pulses are supplied by a generator having the following characteristics $t_r \leq 15$ ns, $t_f \leq 6$ ns, PRR = 1 MHz, duty cycle = 50 %, $Z_{out} \approx 50$ ohms.

FIGURE 2

TYPES SN54LS395A, SN74LS395A 4-BIT CASCADABLE SHIFT REGISTERS WITH 3-STATE OUTPUTS

OCTOBER 1976—REVISED DECEMBER 1983

- Three-State, 4 Bit, Cascadable, Parallel-In, Parallel-Out Registers
- 'LS395A Offers Three Times the Sink-Current Capability of 'LS395
- Low Power Dissipation . . . 75 mW Typical (Enabled)
- Applications:
 - N-Bit Serial-To-Parallel Converter
 - N-Bit Parallel-To-Serial Converter
 - N-Bit Storage Register

description

These 4-bit registers feature parallel inputs, parallel outputs, and clock (CLK), serial (SER), load shift (LD/ \overline{SH}), output control (\overline{OC}) and direct overriding clear (\overline{CLR}) inputs.

Shifting is accomplished when the load/shift input is low. Parallel loading is accomplished by applying the four bits of data and taking the load/shift control input high. The data is loaded into the associated flip-flops and appears at the outputs after the high-to-low transition of the clock input. During parallel loading, the entry of serial data is inhibited.

When the output control is low, the normal logic levels of the four outputs are available for driving the loads or bus lines. The outputs are disabled independently from the level of the clock by a high logic level at the output control input. The outputs then present a high impedance and neither load nor drive the bus line; however, sequential operation of the registers is not affected. During the high-impedance mode, the output at Q_D' is still available for cascading.

SN54LS395A . . . J OR W PACKAGE
SN74LS395A . . . D, J OR N PACKAGE
(TOP VIEW)

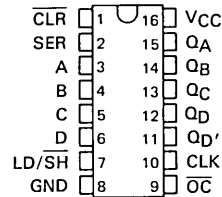

SN54LS395A . . . FK PACKAGE
SN74LS395A . . . FN PACKAGE
(TOP VIEW)

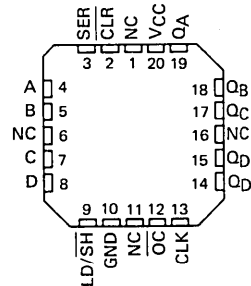

NC - No internal connection

PRODUCTION DATA
This document contains information current as of publication date. Products conform to specifications per the terms of Texas Instruments standard warranty. Production processing does not necessarily include testing of all parameters.

**TEXAS
INSTRUMENTS**

POST OFFICE BOX 225012 • DALLAS, TEXAS 75265

3-1065

TTL DEVICES

TYPES SN54LS395A, SN74LS395A 4-BIT CASCADABLE SHIFT REGISTERS WITH 3-STATE OUTPUTS

logic diagram

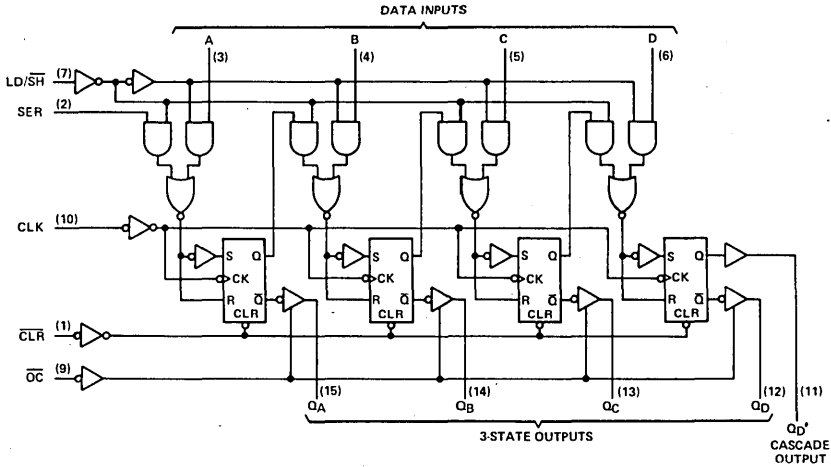

Pin numbers shown on logic notation are for D, J or N packages.

schematics of inputs and outputs

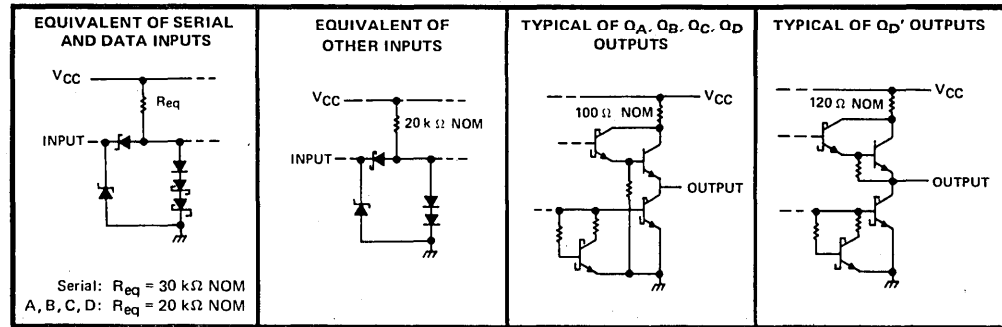

3 TTL DEVICES

TYPES SN54LS395A, SN74LS395A 4-BIT CASCADABLE SHIFT REGISTERS WITH 3-STATE OUTPUTS

FUNCTION TABLE

INPUTS					3-STATE OUTPUTS				CASCADE OUTPUT
CLR	LD/SH	CLK	SER	PARALLEL	Q _A	Q _B	Q _C	Q _D	Q _D '
				A B C D					
L	X	X	X	X X X X	L	L	L	L	L
H	H	H	X	X X X X	Q _{A0}	Q _{B0}	Q _{C0}	Q _{D0}	Q _{D0}
H	H	↓	X	a b c d	a	b	c	d	d
H	L	H	X	X X X X	Q _{A0}	Q _{B0}	Q _{C0}	Q _{D0}	Q _{D0}
H	L	↓	H	X X X X	H	Q _{An}	Q _{Bn}	Q _{Cn}	Q _{Cn}
H	L	↓	L	X X X X	L	Q _{An}	Q _{Bn}	Q _{Cn}	Q _{Cn}

When the output control is high, the 3-state outputs are disabled to the high-impedance state; however, sequential operation of the registers and the output at Q_D' are not affected.

absolute maximum ratings over operating free-air temperature range (unless otherwise noted)

Supply voltage, V _{CC} (see Note 1)	7 V
Input voltage	7 V
Operating free-air temperature range: SN54LS395A	-55°C to 125°C
SN74LS395A	0°C to 70°C
Storage temperature range	-65°C to 150°C

NOTE 1: Voltage values are with respect to network ground terminal.

recommended operating conditions

	SN54LS395A			SN74LS395A			UNIT
	MIN	NOM	MAX	MIN	NOM	MAX	
Supply voltage, V _{CC}	4.5	5	5.5	4.75	5	5.25	V
High-level output current, I _{OH}	Q _A , Q _B , Q _C , Q _D		-1	-2.6		mA	
	Q _D '		-400	-400		μA	
Low-level output current, I _{OL}	Q _A , Q _B , Q _C , Q _D		12	24		mA	
	Q _D '		4	8		mA	
Clock frequency, f _{clock}	0	30	0	30	MHz		
Width of clock pulse, t _{w(clock)}	16		16		ns		
Setup time, high-level or low-level data, t _{su}	LD/SH		40		ns		
	All other inputs		20				
Hold time, high-level or low-level data, t _h	10		10		ns		
Operating free-air temperature, T _A	-55	125	0	70	°C		

3
TTL DEVICES

TYPES SN54LS395A, SN74LS395A

4-BIT CASCADABLE SHIFT REGISTERS WITH 3-STATE OUTPUTS

electrical characteristics over recommended operating free-air temperature range (unless otherwise noted)

PARAMETER	TEST CONDITIONS†	SN54LS395A			SN74LS395A			UNIT
		MIN	TYP‡	MAX	MIN	TYP‡	MAX	
V _{IH} High-level input voltage		2			2			V
V _{IL} Low-level input voltage				0.7			0.8	V
V _{IK} Input clamp voltage	V _{CC} = MIN, I _I = -18 mA			-1.5			-1.5	V
V _{OH} High-level output voltage	V _{CC} = MIN, V _{IH} = 2 V, V _{IL} = V _{IL} max, I _{OH} = MAX	Q _A , Q _B , Q _C , Q _D	2.4	3.4	2.4	3.1		V
		Q _D '	2.5	3.4	2.7	3.4		V
V _{OL} Low-level output voltage	V _{CC} = MIN, V _{IL} = V _{IL} max, V _{IH} = 2 V	Q _A , Q _B , Q _C , Q _D	I _{OL} = 12 mA	0.25	0.4	0.25	0.4	V
			I _{OL} = 24 mA			0.35	0.5	
		Q _D	I _{OL} = 4 mA	0.25	0.4	0.25	0.4	V
			I _{OL} = 8 mA			0.35	0.5	
I _{OZH} Off-state output current, high-level voltage applied	V _{CC} = MAX, V _{IH} = 2 V, V _O = 2.7 V	Q _A , Q _B , Q _C , Q _D		20		20		μA
I _{OZL} Off-state output current, low-level voltage applied	V _{CC} = MAX, V _{IH} = 2 V, V _O = 0.4 V	Q _A , Q _B , Q _C , Q _D		-20		-20		μA
I _I Input current at maximum input voltage	V _{CC} = MAX, V _I = 7 V			0.1		0.1		mA
I _{IH} High-level input current	V _{CC} = MAX, V _I = 2.7 V			20		20		μA
I _{IL} Low-level input current	V _{CC} = MAX, V _I = 0.4 V			-0.4		-0.4		mA
I _{OS} Short-circuit output current§	V _{CC} = MAX	Q _A , Q _B , Q _C , Q _D	-30	-130	-30	-130		mA
		Q _D '	-20	-100	-20	-100		mA
I _{CC} Supply current	V _{CC} = MAX, See Note 2	Condition A	22	34	22	34		mA
		Condition B	21	31	21	31		mA

† For conditions shown as MIN or MAX, use the appropriate value specified under recommended operating conditions.

‡ All typical values are at V_{CC} = 5 V, T_A = 25°C.

§ Not more than one output should be shorted at a time, and duration of the short-circuit should not exceed one second.

NOTE 2: I_{CC} is measured with the outputs open, the serial input and mode control at 4.5 V, and the data inputs grounded under the following conditions:

- Output control at 4.5 V and a momentary 3 V, then ground, applied to clock input.
- Output control and clock input grounded.

switching characteristics, V_{CC} = 5 V, T_A = 25°C

PARAMETER	TEST CONDITIONS	MIN	TYP	MAX	UNIT
f _{max} Maximum clock frequency		30	45		MHz
t _{PHL} Propagation delay time, high-to-low-level output from clear	See Note 3,		22	35	ns
t _{PLH} Propagation delay time, low-to-high-level output	Q _A , Q _B , Q _C , Q _D outputs:		15	30	ns
t _{PHL} Propagation delay time, high-to-low-level output	R _L = 667 Ω, C _L = 45 pF		20	30	ns
t _{PZH} Output enable time to high level	Q _D ' output:		15	25	ns
t _{PZL} Output enable time to low level	R _L = 2 kΩ, C _L = 15 pF		17	25	ns
t _{PHZ} Output disable time from high level	C _L = 5 pF,		11	17	ns
t _{PLZ} Output disable time from low level	See Note 3		12	20	ns

NOTE 3: See General Information Section for load circuits and voltage waveforms.

3 TTL DEVICES

TYPES SN54LS396, SN74LS396 OCTAL STORAGE REGISTERS

D2329, MARCH 1977—PREVISED DECEMBER 1983

- Parallel Access
- Typical Propagation Delay Time . . . 20 ns
- Typical Power Dissipation . . . 120 mW
- Applications:
N-Bit Storage Files
Hex/BCD Serial-To-Parallel Converters

description

These octal registers are organized as two 4-bit bytes of storage. Upon application of a positive-going clock signal, the information stored in byte 1 is transferred into byte 2 as a new 4-bit byte is loaded into the byte 1 location via the four data lines. The full 8-bit word is available at the outputs after two clock cycles. Both the clock and the strobe lines are fully buffered.

logic symbol

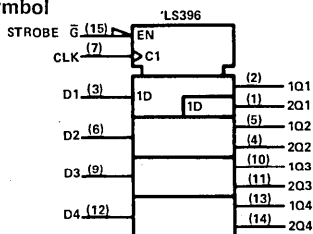

Pin numbers shown on logic notation are for D, J or N packages.

SN54LS396 . . . J OR W PACKAGE
SN74LS396 . . . D, J OR N PACKAGE

(TOP VIEW)

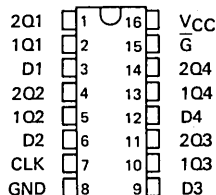

SN54LS396 . . . FK PACKAGE
SN74LS396 . . . FN PACKAGE

(TOP VIEW)

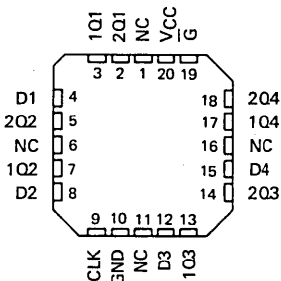

NC - No internal connection

FUNCTION TABLE

INPUTS		OUTPUTS											
		DATA				BYTE 1				BYTE 2			
STROBE \bar{G}	CLOCK	D1	D2	D3	D4	1Q1	1Q2	1Q3	1Q4	2Q1	2Q2	2Q3	2Q4
H	X	X	X	X	X	L	L	L	L	L	L	L	L
L	↑	a	b	c	d	a	b	c	d	1Q1 _n	1Q2 _n	1Q3 _n	1Q4 _n

H = high level (steady state), L = low level (steady state), X = irrelevant (any input, including transitions)

↑ = transition from low to high level

1Q1_n, 1Q2_n, 1Q3_n, 1Q4_n = the level of 1Q1, 1Q2, 1Q3, and 1Q4, respectively, before the most recent ↑ transition of the clock.

PRODUCTION DATA

This document contains information current as of publication date. Products conform to specifications per the terms of Texas Instruments standard warranty. Production processing does not necessarily include testing of all parameters.

TEXAS
INSTRUMENTS

POST OFFICE BOX 225012 • DALLAS, TEXAS 75265

3-1069

3

TTL DEVICES

TYPES SN54LS396, SN74LS396 OCTAL STORAGE REGISTERS

logic diagram

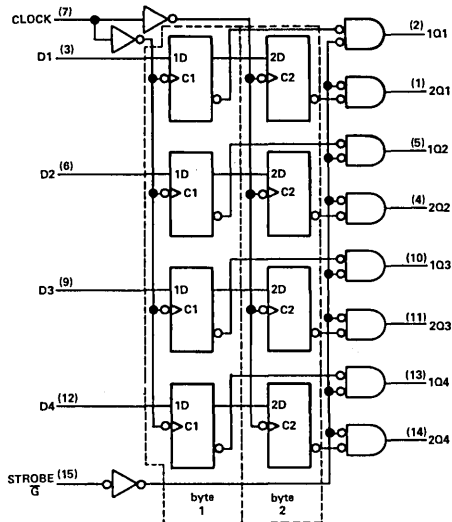

Pin numbers shown on logic notation are for D, J or N packages.

schematics of inputs and outputs

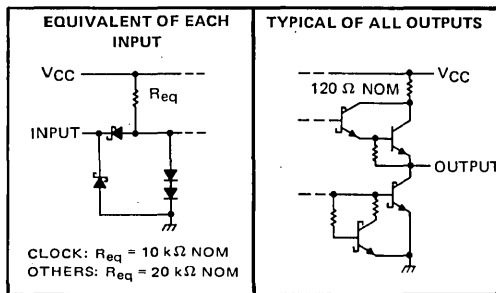

absolute maximum ratings over operating free-air temperature range (unless otherwise noted)

Supply voltage, V_{CC} (see Note 1)	7 V
Input voltage	7 V
Operating free-air temperature range: SN54LS396	-55°C to 125°C
SN74LS396	0°C to 70°C
Storage temperature range	-65°C to 150°C

NOTE 1: Voltage values are with respect to network ground terminal.

recommended operating conditions

	SN54LS396			SN74LS396			UNIT
	MIN	NOM	MAX	MIN	NOM	MAX	
Supply voltage, V_{CC}	4.5	5	5.5	4.75	5	5.25	V
High-level output current, I_{OH}			-400			-400	μA
Low-level output current, I_{OL}			4			8	mA
Clock frequency, f_{clock}	0		30	0		30	MHz
Width of clock pulse, t_w	20			20			ns
Setup time, t_{SU}	20			20			ns
Hold time, t_H	5			5			ns
Operating free-air temperature, T_A	-55		125	0		70	°C

TYPES SN54LS396, SN74LS396 OCTAL STORAGE REGISTERS

electrical characteristics over recommended operating free-air temperature range (unless otherwise noted)

PARAMETER		TEST CONDITIONS†	SN54LS396			SN74LS396			UNIT
			MIN	TYP‡	MAX	MIN	TYP‡	MAX	
V _{IH}	High-level input voltage		2			2			V
V _{IL}	Low-level input voltage		0.7			0.8			V
V _{IK}	Input clamp voltage	V _{CC} = MIN, I _I = -18 mA	-1.5			-1.5			V
V _{OH}	High-level output voltage	V _{CC} = MIN, V _{IH} = 2 V, V _{IL} = MAX, I _{OH} = -400 µA	2.5	3.4		2.7	3.4		V
V _{OL}	Low-level output voltage	V _{CC} = MIN, V _{IH} = 2 V, V _{IL} = MAX, I _{OL} = 4 mA	0.25	0.4		0.25	0.4		V
		V _{CC} = MIN, V _{IH} = 2 V, V _{IL} = MAX, I _{OL} = 8 mA				0.35	0.5		
I _I	Input current at maximum input voltage	Clock input Other inputs	V _{CC} = MAX, V _I = 7 V			0.2			mA
						0.1			
I _{IH}	High-level input current	Clock input Other inputs	V _{CC} = MAX, V _I = 2.7 V			40			µA
						20			
I _{IL}	Low-level input current	Clock input Other inputs	V _{CC} = MAX, V _I = 0.4 V			-0.8			mA
						-0.4			
I _{OS}	Short-circuit output current§	V _{CC} = MAX	-20	-100	-20	-100		mA	
I _{CC}	Supply current	V _{CC} = MAX, See Note 2	24	40	24	40		mA	

† For conditions shown as MIN or MAX, use the appropriate value specified under recommended operating conditions.

‡ All typical values are at V_{CC} = 5 V, T_A = 25°C.

§ Not more than one output should be shorted at a time and duration of the short-circuit should not exceed one second.

NOTE 2: I_{CC} is measured with 4.5 V applied to all inputs and all outputs open.

switching characteristics, V_{CC} = 5 V, T_A = 25°C

PARAMETER		TEST CONDITIONS	MIN	TYP	MAX	UNIT
t _{PLH}	Propagation delay time, low-to-high-level output from clock		C _L = 15 pF, R _L = 2 kΩ, See Note 3		20	
t _{PHL}	Propagation delay time, high-to-low-level output from clock			20	30	
t _{PLH}	Propagation delay time, low-to-high-level output from strobe			20	30	ns
t _{PHL}	Propagation delay time, high-to-low-level output from strobe			20	30	

NOTE 3: See General Information Section for load circuits and voltage waveforms.

3
TTL DEVICES



TTL DEVICES

TYPES SN54LS398, SN54LS399 SN74LS398, SN74LS399 QUADRUPLE 2-INPUT MULTIPLEXERS WITH STORAGE

OCTOBER 1976—REVISED DECEMBER 1983

- Double-Rail Outputs on 'LS398
- Single-Rail Outputs on 'LS399
- 'LS398 is Similar to 'LS298, Which Has Inverted Clock
- Selects One of Two 4-Bit Data Sources and Stores Data Synchronously with System Clock

- Applications:
Dual Source for Operands and Constants in Arithmetic Processor; Can Release Processor Register Files for Acquiring New Data

Implement Separate Registers Capable of Parallel Exchange of Contents Yet Retain External Load Capability

Universal Type Register for Implementing Various Shift Patterns; Even Has Compound Left-Right Capabilities

description

These monolithic quadruple two-input multiplexers with storage provide essentially the equivalent functional capabilities of two separate MSI functions (SN54LS157/SN74LS157 and SN54LS175/SN74LS175) in a single 16-pin or 20-pin package.

When the word-select input is low, word 1 (A1, B1, C1, D1) is applied to the flip-flops. A high input to word select will cause the selection of word 2 (A2, B2, C2, D2). The selected word is clocked to the output terminals on the positive-going edge of the clock pulse.

Typical power dissipation is 37 milliwatts. SN54LS398 and SN54LS399 are characterized for operation over the full military range of -55°C to 125°C , SN74LS398 and SN74LS399 are characterized for operation from 0°C to 70°C .

FUNCTION TABLE

INPUTS		OUTPUTS			
WORD SELECT	CLOCK	Q _A	Q _B	Q _C	Q _D
L	↑	a1	b1	c1	d1
H	↑	a2	b2	c2	d2
X	L	Q _{A0}	Q _{B0}	Q _{C0}	Q _{D0}

SN54LS398 ... J OR W PACKAGE
SN74LS398 ... DW, J OR N PACKAGE
(TOP VIEW)

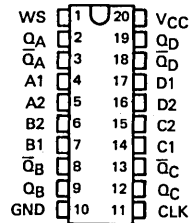

SN54LS398 ... FK PACKAGE
SN74LS398 ... FN PACKAGE
(TOP VIEW)

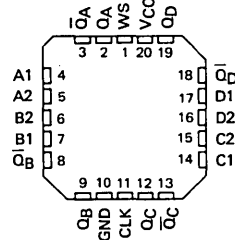

SN54LS399 ... J OR W PACKAGE
SN74LS399 ... D, J OR N PACKAGE
(TOP VIEW)

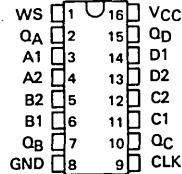

SN54LS399 ... FK PACKAGE
SN74LS399 ... FN PACKAGE
(TOP VIEW)

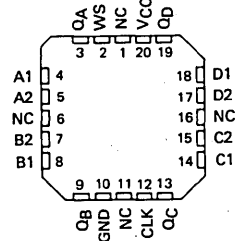

NC - No internal connection

PRODUCTION DATA
This document contains information current as of publication date. Products conform to these specifications per the terms of Texas Instruments standard warranty. Production processing does not necessarily include testing of all parameters.

TYPES SN54LS398, SN54LS399, SN74LS398, SN74LS399 QUADRUPLE 2-INPUT MULTIPLEXERS WITH STORAGE

logic diagram

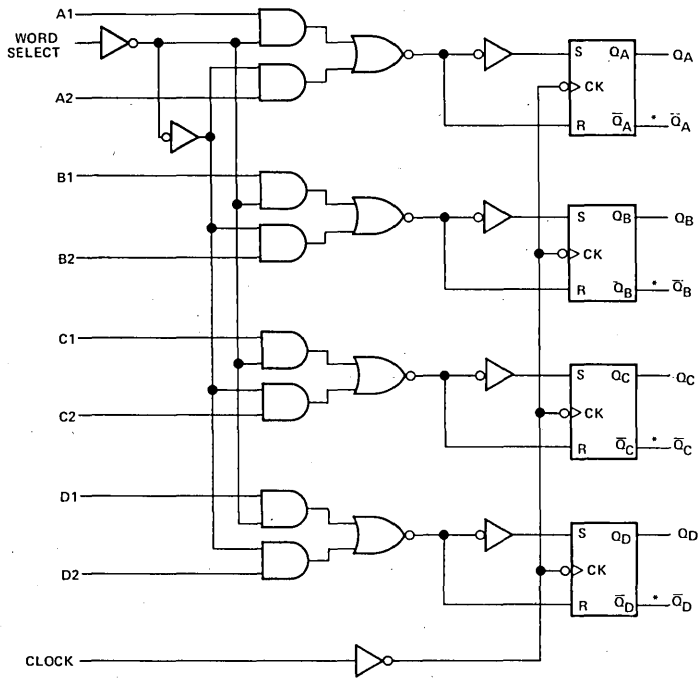

• 'LS398 Only

3 TTL DEVICES

schematics of inputs and outputs

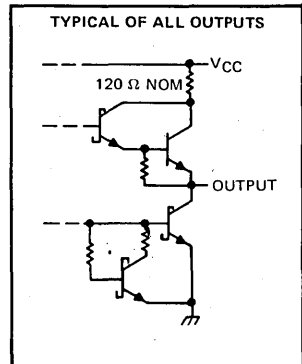
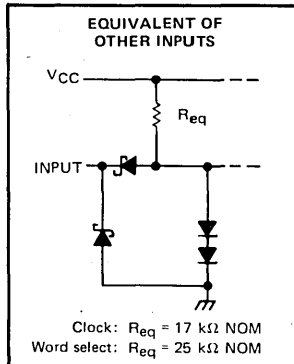
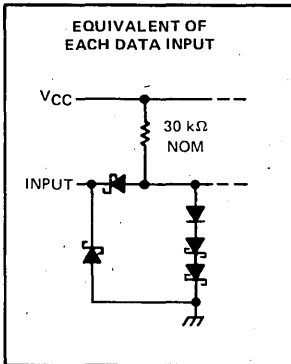

TYPES SN54LS398, SN54LS399, SN74LS398, SN74LS399 QUADRUPLE 2-INPUT MULTIPLEXERS WITH STORAGE

absolute maximum ratings over operating free-air temperature range (unless otherwise noted)

Supply voltage, V_{CC} (see Note 1)	7 V
Input voltage	7 V
Operating free-air temperature range: SN54LS'	-55°C to 125°C
SN74LS'	0°C to 70°C
Storage temperature range	-65°C to 150°C

NOTE 1: Voltage values are with respect to network ground terminal.

recommended operating conditions

		SN54LS'			SN74LS'			UNIT		
		MIN	NOM	MAX	MIN	NOM	MAX			
Supply voltage, V_{CC}		4.5	5	5.5	4.75	5	5.25	V		
High-level output current, I_{OH}					-400			μ A		
Low-level output current, I_{OL}					8			mA		
Width of clock pulse, high or low level, t_w		20			20			ns		
Setup time, t_{su}	Data	25			25			ns		
	Word select	45			45					
Hold time, t_h	Data	0			0			ns		
	Word select	0			0					
Operating free-air temperature, T_A		-55			125			0	70	°C

electrical characteristics over recommended operating free-air temperature range (unless otherwise noted)

PARAMETER	TEST CONDITIONS†	SN54LS'			SN74LS'			UNIT
		MIN	TYP‡	MAX	MIN	TYP‡	MAX	
V_{IH} High-level input voltage		2			2			V
V_{IL} Low-level input voltage					0.7			V
V_{IK} Input clamp voltage	$V_{CC} = \text{MIN}, I_I = -18 \text{ mA}$				-1.5			V
V_{OH} High-level output voltage	$V_{CC} = \text{MIN}, V_{IH} = 2 \text{ V}, V_{IL} = V_{IL\text{max}}, I_{OH} = -400 \mu\text{A}$	2.5	3.4		2.7	3.4		V
V_{OL} Low-level output voltage	$V_{CC} = \text{MIN}, V_{IH} = 2 \text{ V}, V_{IL} = V_{IL\text{max}}$	$I_{OL} = 4 \text{ mA}$		0.25	0.4	0.25	0.4	V
		$I_{OL} = 8 \text{ mA}$				0.35	0.5	
I_I Input current at maximum input voltage	$V_{CC} = \text{MAX}, V_I = 7 \text{ V}$				0.1			mA
I_{IH} High-level input current	$V_{CC} = \text{MAX}, V_I = 2.7 \text{ V}$				20			μ A
I_{IL} Low-level input current	$V_{CC} = \text{MAX}, V_I = 0.4 \text{ V}$				-0.4			mA
I_{OS} Short-circuit output current§	$V_{CC} = \text{MAX}$	-20			-100			mA
I_{CC} Supply current	$V_{CC} = \text{MAX},$ See Note 2	7.3			13			mA

† For conditions shown as MIN or MAX, use the appropriate value specified under recommended operating conditions.

‡ All typical values are at $V_{CC} = 5 \text{ V}, T_A = 25^\circ \text{C}$.

§ Not more than one output should be shorted at a time, duration of the short-circuit should not exceed one second.

NOTE 2: With all outputs open and all inputs except clock low, I_{CC} is measured after applying a momentary 4.5 V, followed by ground, to the clock input.

switching characteristics, $V_{CC} = 5 \text{ V}, T_A = 25^\circ \text{C}$

PARAMETER	TEST CONDITIONS	MIN	TYP	MAX	UNIT
t_{PLH} Propagation delay time, low-to-high-level output	$C_L = 15 \text{ pF}, R_L = 2 \text{ k}\Omega,$		18	27	ns
t_{PHL} Propagation delay time, high-to-low-level output	See Note 3		21	32	

NOTE 3: See General Information Section for load circuits and voltage waveforms.

3

TTL DEVICES



TTL DEVICES

TYPES SN54S412, SN74S412 (TIM8212) MULTI-MODE BUFFERED LATCHES

OCTOBER 1975—REVISED DECEMBER 1983

- PNP Inputs and 3-State Outputs Maximize I/O and Data Bus Capabilities
- Data Latch Transparency Permits Asynchronous or Latched Receiver Modes
- Mode and Select Inputs Permit Storing With Outputs Enabled or Disabled
- Strobe-Controlled Flag Flip-Flop Indicates Status or Interrupt
- Asynchronous Clear Sets All Eight Data Latches Low and Initializes Status Flag
- High-Level Output Voltage, Typically 4 V, Drives Most MOS Functions Directly
- Direct Replacement for Intel 3212 or 8212 in Most Applications

description

This high-performance eight-bit parallel expandable buffer register incorporates package and mode selection inputs and an edge-triggered status flip-flop designed specifically for implementing bus-organized input/output ports. The three-state data outputs can be connected to a common data bus and controlled from the appropriate select inputs to receive or transmit data. An integral status flip-flop provides package busy or request interrupt commands. The outputs, with a 4-volt typical high-level voltage, are compatible for driving low-threshold MOS directly.

DATA LATCHES

The eight data latches are fully transparent when the internal gate enable, G, input is high and the outputs are enabled (OE = H). Latch transparency is selected by the mode control (M), select (S_1 and S_2), and the strobe (STB) inputs and during transparency each data output (DO_j) follows its respective data input (DI_j). This mode of operation can be terminated by clearing, de-selecting, or holding the data latches. See data latches function table.

MODE SELECTION

An input mode or an output mode is selectable from this single input line. In the input mode, MD = L, the eight data latch inputs are enabled when the strobe is high regardless of device selection. If selected during an input mode, the outputs will follow the data inputs. When the strobe input is taken low, the latches will store the most-recently setup data.

In the output mode, M = H, the output buffers are enabled regardless of any other control input. During the output mode the content of the register is under control of the select (S_1 and S_2) inputs. See data latches function table.

SN54S412 . . . J PACKAGE
SN74S412 . . . DW, J OR N PACKAGE
(TOP VIEW)

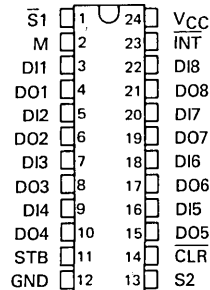

SN54S412 . . . FK PACKAGE
SN74S412 . . . FN PACKAGE
(TOP VIEW)

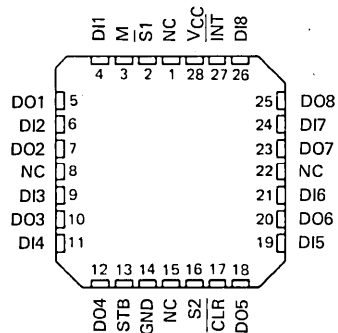

NC - No internal connection



TTL DEVICES

PRODUCTION DATA
This document contains information current as of publication date. Products conform to specifications per the terms of Texas Instruments standard warranty. Production processing does not necessarily include testing of all parameters.

TEXAS
INSTRUMENTS

POST OFFICE BOX 225012 • DALLAS, TEXAS 75265

3-1077

TYPES SN54S412, SN74S412 (TIM8212) MULTI-MODE BUFFERED LATCHES

STATUS FLIP-FLOP

The status flip-flop provides a low-level output signal when:

- a. the package is selected
- b. a strobe input is received.

This status signal can be used to indicate that the register is busy or to initiate an interrupt type command.

logic diagram

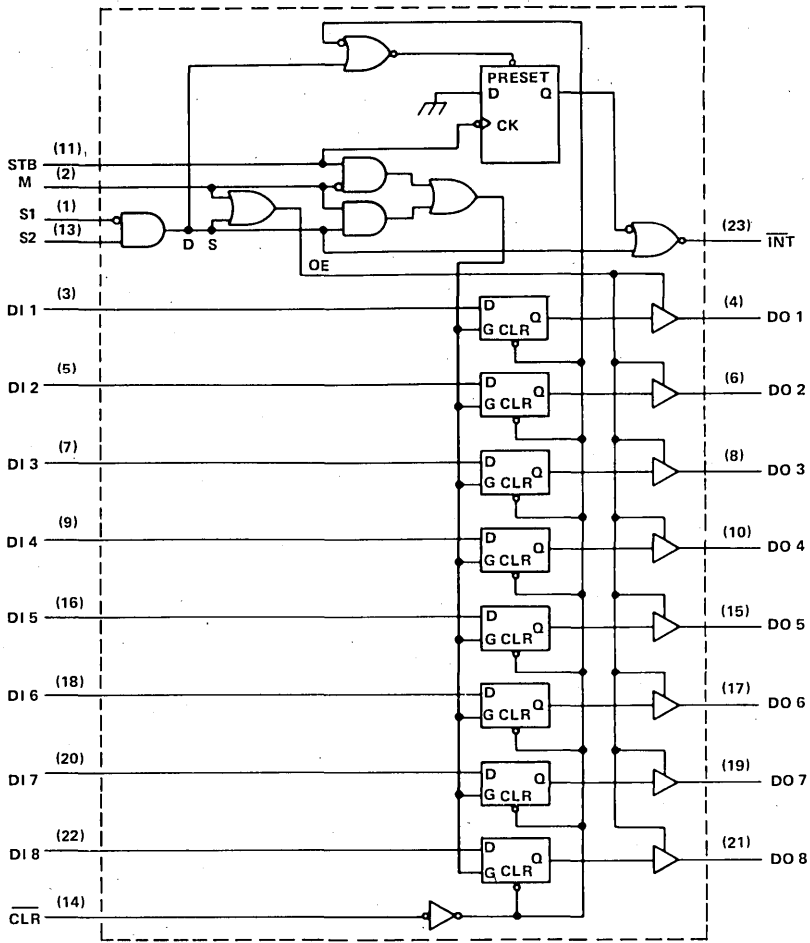

Pin numbers shown on logic notation are for DW, J or N packages.

TYPES SN54S412, SN74S412 (TIM8212) MULTI-MODE BUFFERED LATCHES

schematics of inputs and outputs

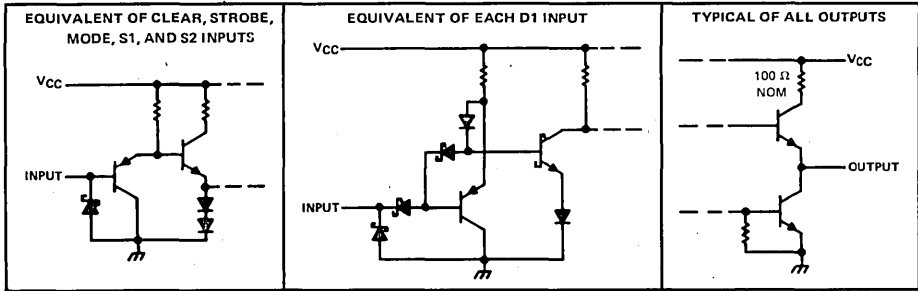

DATA LATCHES FUNCTION TABLE

FUNCTION	CLEAR	M	$\bar{S}1$	S2	STB	DATA IN	DATA OUT
Clear	L	H	H	X	X	X	L
	L	L	L	H	L	X	L
De-select	X	L	X	L	X	X	Z
	X	L	H	X	X	X	Z
Hold	H	H	H	L	X	X	Q_0
	H	L	L	H	L	X	\bar{Q}_0
Data Bus	H	H	L	H	X	L	L
	H	H	L	H	X	H	H
Data Bus	H	L	L	H	H	L	L
	H	L	L	H	H	H	H

STATUS FLIP-FLOP FUNCTION TABLE

CLEAR	$\bar{S}1$	S2	STB	\bar{INT}
L	H	X	X	H
L	X	L	X	H
H	X	X	↓	L
H	L	H	X	L

H \equiv high level (steady state)
L \equiv low level (steady state)
X \equiv irrelevant (any input, including transitions)
Z \equiv high impedance (off)
↓ \equiv transition from low to high level

absolute maximum ratings over operating free-air temperature range (unless otherwise noted)

Supply voltage, V_{CC} (see Note 1)	7 V
Input voltage	5.5 V
Operating free-air temperature range: SN54S412	-55°C to 125°C
SN74S412	0°C to 70°C
Storage temperature range	-65°C to 150°C

NOTE 1: Voltage values are with respect to network ground terminal.

recommended operating conditions

	SN54S412			SN74S412			UNIT		
	MIN	NOM	MAX	MIN	NOM	MAX			
Supply voltage, V_{CC}	4.5	5	5.5	4.75	5	5.25	V		
Pulse width, t_w (see Figures 1, 2, and 4)	STB or $\bar{S}1 \cdot S2$			25			ns		
	Clear low			25					
Setup time, t_{SU} (see Figure 3)	15↓			15↓			ns		
Hold time, t_H (see Figures 1 and 3)	20↓			20↓			ns		
Operating free-air temperature, T_A	-55			125			0	70	°C

↓ The arrow indicates that the falling edge of the clock pulse is used for reference.

3
TTL DEVICES

TYPES SN54S412, SN74S412 (TIM8212) MULTI-MODE BUFFERED LATCHES

electrical characteristics over recommended operating free-air temperature range (unless otherwise noted)

PARAMETER		TEST CONDITIONS†	SN54S412			SN74S412			UNIT	
			MIN	TYP‡	MAX	MIN	TYP‡	MAX		
V _{IH}	High-level input voltage		2			2			V	
V _{IL}	Low-level input voltage		0.85			0.85			V	
V _{IK}	Input clamp voltage	V _{CC} = MIN; I _I = -18 mA	-1.2			-1.2			V	
V _{OH}	High-level output voltage	V _{CC} = MIN, V _{IH} = 2 V, V _{IL} = 0.8 V, I _{OH} = -1 mA	3.4	4		3.65	4		V	
V _{OL}	Low-level output voltage	V _{CC} = MIN, V _{IH} = 2 V, V _{IL} = 0.85 V	I _{OL} = 15 mA			0.45			V	
			I _{OL} = 20 mA			0.5				
I _{OZH}	Off-state output current, high-level voltage applied	DO 1 thru DO 8	V _{CC} = MAX, V _O = 2.4 V			50			μA	
I _{OZL}	Off-state output current, low-level voltage applied	DO 1 thru DO 8	V _{CC} = MAX, V _O = 0.5 V			-50			μA	
I _I	Input current at maximum input voltage		V _{CC} = MAX, V _I = 5.5 V			1			mA	
I _{IH}	High-level input current		V _{CC} = MAX, V _I = 5.25 V			20			μA	
I _{IL}	Low-level input current	S1	V _{CC} = MAX, V _I = 0.4 V			-1			mA	
		M				-0.75				
		All others				-0.25				
I _{OS}	Short-circuit output current§		V _{CC} = MAX			-20	-65	-20	-65	mA
I _{CC}	Supply current		V _{CC} = MAX, see Note 2			82			82 130	mA

† For conditions shown as MIN or MAX, use the appropriate value specified under recommended operating conditions.

‡ All typical values are at V_{CC} = 5 V, T_A = 25° C.

§ Not more than one output should be shorted at a time.

NOTE 2: I_{CC} is measured with all outputs open, clear input at 4.5 V, and all other inputs grounded.

switching characteristics, V_{CC} = 5 V, T_A = 25° C

PARAMETER	FROM	TO	FIGURE	TEST CONDITIONS	MIN	TYP	MAX	UNIT	
t _{PLH}	STB, S1, or S2	Any DO	1	C _L = 30 pF, See Note 3	18	27		ns	
t _{PHL}					15	25			
t _{PHL}	CLR	Any DO	2		18	27		ns	
t _{PLH}					12	20			
t _{PHL}	D _i	DO _i	3		10	20		ns	
t _{PLH}					12	20			
t _{PLH}	S1 or S2	INT	4	C _L = 30 pF, See Note 3	12	20		ns	
t _{PHL}					16	25			
t _{PZH}	S1, S2, or M	Any DO	5		21	35		ns	
t _{PZL}					25	40			
t _{PHZ}	S1, S2, or M	Any DO	5		C _L = 5 pF, See Note 3	9	20		ns
t _{PLZ}						12	20		

t_{PLH} ≡ propagation delay time, low-to-high-level output

t_{PHL} ≡ propagation delay time, high-to-low-level output

t_{PZH} ≡ output enable time to high level

t_{PZL} ≡ output enable time to low level

t_{PHZ} ≡ output disable time from high level

t_{PLZ} ≡ output disable time from low level

NOTE 3: See General Information Section for load circuits and voltage waveforms.

3

TTL DEVICES

PARAMETER MEASUREMENT INFORMATION

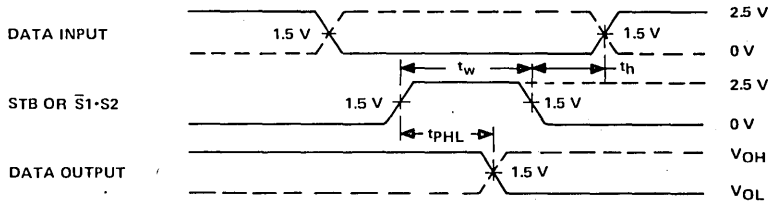

FIGURE 1 – STROBE OR SELECT TO DATA OUTPUT

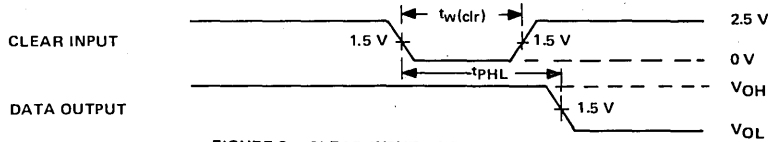

FIGURE 2 – CLEAR INPUT TO DATA OUTPUT

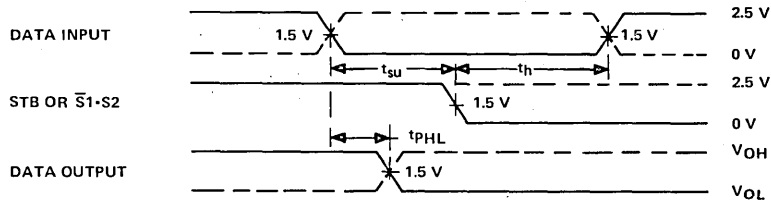

FIGURE 3 – DATA INPUT TO DATA OUTPUT

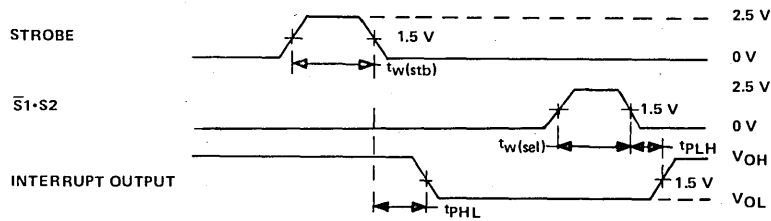

FIGURE 4 – STROBE OR SELECT TO INTERRUPT OUTPUT

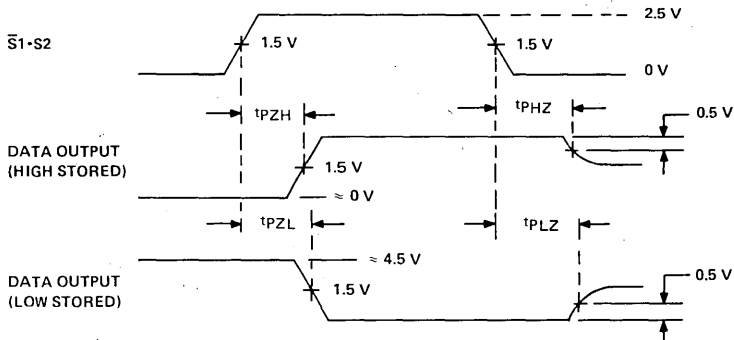

FIGURE 5 – SELECT TO DATA OUTPUT

3
TTL DEVICES

TYPES SN54LS422, SN54LS423, SN74LS422, SN74LS423 RETRIGGERABLE MONOSTABLE MULTIVIBRATORS

D2536, JANUARY 1980

- Will Not Trigger from Clear
- D-C Triggered from Active-High or Active-Low Gated Logic Inputs
- Retriggerable for Very Long Output Pulses, Up to 100% Duty Cycle
- Overriding Clear Terminates Output Pulse
- 'LS422 Has Internal Timing Resistor

description

The 'LS422 and 'LS423 are identical to 'LS122 and 'LS123 except they cannot be triggered via clear.

These d-c triggered multivibrators feature output-pulse-width control by three methods. The basic pulse time is programmed by selection of external resistance and capacitance values (see typical application data). The 'LS422 contains an internal timing resistor that allows the circuits to be used with only an external capacitor, if so desired. Once triggered, the basic pulse width may be extended by retriggering the gated low-level-active (A) or high-level-active (B) inputs, or be reduced by use of the overriding clear. Figure 1 illustrates pulse control by retriggering and early clear.

The 'LS422 and 'LS423 have enough Schmitt hysteresis to ensure jitter-free triggering from the B input with transition rates as slow as 0.1 millivolt per nanosecond. The 'LS422 R_{int} is nominally 10 k ohms.

The SN54LS422 and SN54LS423 are characterized for operation over the full military temperature range of -55°C to 125°C . The SN74LS422 and SN74LS423 are characterized for operation from 0°C to 70°C .

SN54LS423 ... J OR W PACKAGE
SN74LS423 ... D, J OR N PACKAGE
(TOP VIEW) (SEE NOTES 1 THRU 4)

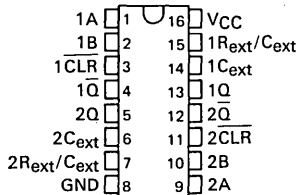

SN54LS422 ... J OR W PACKAGE
SN74LS422 ... D, J OR N PACKAGE
(TOP VIEW) (SEE NOTES 1 THRU 4)

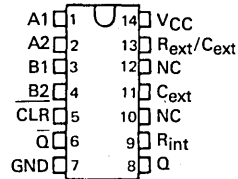

SN54LS422 ... FK PACKAGE
SN74LS422 ... FN PACKAGE
(TOP VIEW) (SEE NOTES 1 THRU 4)

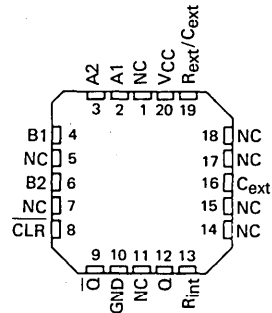

SN54LS423 ... FK PACKAGE
SN74LS423 ... FN PACKAGE
(TOP VIEW) (SEE NOTES 1 THRU 4)

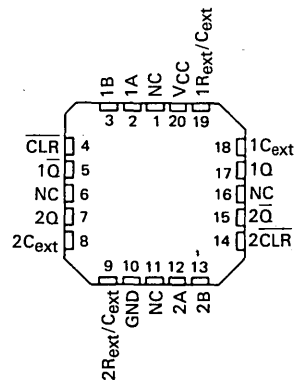

- NOTES:
1. An external timing capacitor may be connected between C_{ext} and R_{ext}/C_{ext} (positive).
 2. To use the internal timing resistor of 'LS422, connect R_{int} to V_{CC} .
 3. For improved pulse width accuracy and repeatability, connect an external resistor between R_{ext}/C_{ext} and V_{CC} with R_{int} open-circuited.
 4. To obtain variable pulse widths, connect an external variable resistance between R_{int} or R_{ext}/C_{ext} and V_{CC} .

PRODUCTION DATA
This document contains information current as of publication date. Products conform to specifications per the terms of Texas Instruments standard warranty. Production processing does not necessarily include testing of all parameters.

**TEXAS
INSTRUMENTS**

POST OFFICE BOX 225012 • DALLAS, TEXAS 75265

3

TTL DEVICES

3-1083

TYPES SN54LS422, SN54LS423, SN74LS422, SN74LS423 RETRIGGERABLE MONOSTABLE MULTIVIBRATORS

description (continued)

'LS422
FUNCTION TABLE

CLEAR	INPUTS				OUTPUTS	
	A1	A2	B1	B2	Q	\bar{Q}
L	X	X	X	X	L	H
X	H	H	X	X	L \uparrow	H \uparrow
X	X	X	L	X	L \uparrow	H \uparrow
X	X	X	X	L	L \uparrow	H \uparrow
H	L	X	\uparrow	H	\square	\square
H	L	X	H	\uparrow	\square	\square
H	X	L	\uparrow	H	\square	\square
H	X	L	H	\uparrow	\square	\square
H	H	\downarrow	H	H	\square	\square
H	\downarrow	\downarrow	H	H	\square	\square
H	\downarrow	H	H	H	\square	\square

'LS423
FUNCTION TABLE

CLEAR	INPUTS		OUTPUTS	
	A	B	Q	\bar{Q}
L	X	X	L	H
X	H	X	L \uparrow	H \uparrow
X	X	L	L \uparrow	H \uparrow
H	L	\uparrow	\square	\square
H	\uparrow	H	\square	\square

† These lines of the functional tables assume that the indicated steady-state conditions at the A and B inputs have been set up long enough to complete any pulse started before the set up.

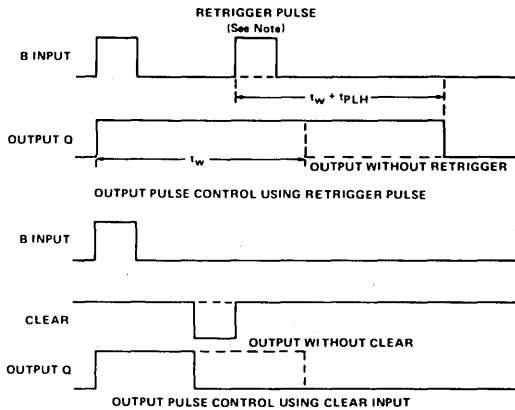

NOTE: Retrigger pulses starting before $0.22 C_{ext}$ (in picoseconds) nanoseconds after the initial trigger pulse will be ignored and the output pulse will remain unchanged.

FIGURE 1—TYPICAL INPUT/OUTPUT PULSES

TYPES SN54LS422, SN54LS423, SN74LS422, SN74LS423 RETRIGGERABLE MONOSTABLE MULTIVIBRATORS

logic symbols

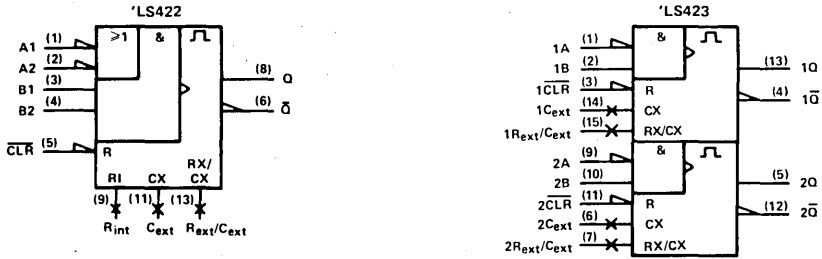

logic diagrams

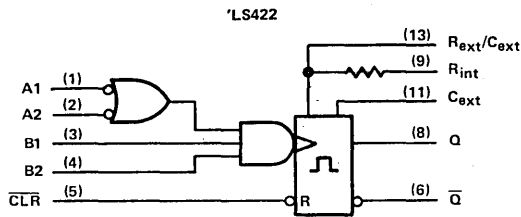

R_{int} is nominally 10 k ohms

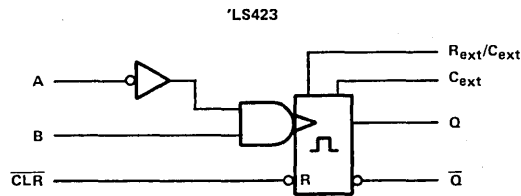

Pin numbers shown on logic notation are for D, J or N packages.

schematics of inputs and outputs

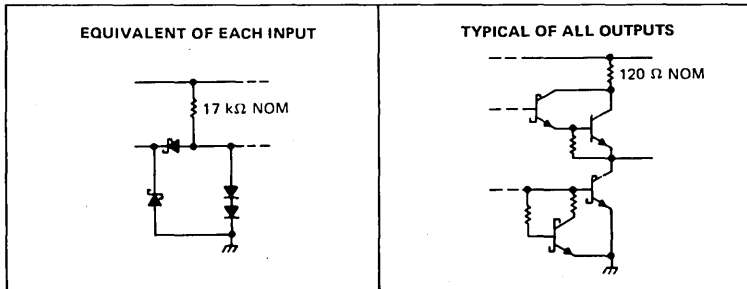

TYPES SN54LS422, SN54LS423, SN74LS422, SN74LS423 RETRIGGERABLE MONOSTABLE MULTIVIBRATORS

recommended operating conditions

	SN54LS*			SN74LS*			UNIT
	MIN	NOM	MAX	MIN	NOM	MAX	
Supply voltage, V_{CC}	4.5	5	5.5	4.75	5	5.25	V
High-level output current, I_{OH}	-400			-400			μ A
Low-level output current, I_{OL}	4			8			mA
Pulse width, t_w	40			40			ns
External timing resistance, R_{ext}	5			180			k Ω
External capacitance, C_{ext}	No restriction			No restriction			
Wiring capacitance at R_{ext}/C_{ext} terminal	50			50			pF
Operating free-air temperature, T_A	-55			125			0
				70			$^{\circ}$ C

electrical characteristics over recommended operating free-air temperature range (unless otherwise noted)

PARAMETER	TEST CONDITIONS†	SN54LS*			SN74LS*			UNIT
		MIN	TYP‡	MAX	MIN	TYP‡	MAX	
V_{IH} High-level input voltage		2			2			V
V_{IL} Low-level input voltage		0.7			0.8			V
V_{IK} Input clamp voltage	$V_{CC} = \text{MIN}, I_I = -18 \text{ mA}$	-1.5			-1.5			V
V_{OH} High-level output voltage	$V_{CC} = \text{MIN}, V_{IL} = V_{ILmax}, I_{OH} = -400 \mu\text{A}$	2.5	3.5		2.7	3.5		V
V_{OL} Low-level output voltage	$V_{CC} = \text{MIN}, V_{IL} = V_{ILmax}, I_{OL} = 4 \text{ mA}$ $I_{OL} = 8 \text{ mA}$	0.25	0.4		0.25	0.4		V
I_I Input current at maximum input voltage	$V_{CC} = \text{MAX}, V_I = 7 \text{ V}$	0.1			0.1			mA
I_{IH} High-level input current	$V_{CC} = \text{MAX}, V_I = 2.7 \text{ V}$	20			20			μ A
I_{IL} Low-level input current	$V_{CC} = \text{MAX}, V_I = 0.4 \text{ V}$	-0.4			-0.4			mA
I_{OS} Short-circuit output current*	$V_{CC} = \text{MAX}$	-20	-100		-20	-100		mA
I_{CC} Supply current (quiescent or triggered)	$V_{CC} = \text{MAX},$ See Note 6	'LS422 6 11		6 11		'LS423 12 20		mA

† For conditions shown as MIN or MAX, use the appropriate value specified under recommended operating conditions.

‡ All typical values are at $V_{CC} = 5 \text{ V}, T_A = 25^{\circ}\text{C}$.

* Not more than one output should be shorted at a time and duration of the short-circuit should not exceed one second.

NOTES: 5. To measure V_{OH} at Q, V_{OL} at \bar{Q} , or I_{OS} at Q, ground R_{ext}/C_{ext} , apply 2 V to B and clear, and pulse A from 2 V to 0 V.

6. With all outputs open and 4.5 V applied to all data and clear inputs, I_{CC} is measured after a momentary ground, then 4.5 V, is applied to clock.

switching characteristics, $V_{CC} = 5 \text{ V}, T_A = 25^{\circ}\text{C}$, see note 7

PARAMETER¶	FROM (INPUT)	TO (OUTPUT)	TEST CONDITIONS	MIN	TYP	MAX	UNIT
t_{PLH}	A	Q	$C_{ext} = 0, R_{ext} = 5 \text{ k}\Omega,$ $C_L = 15 \text{ pF}, R_L = 2 \text{ k}\Omega$	23	33		ns
	B	Q		23	44		
t_{PHL}	A	\bar{Q}		32	45		ns
	B	\bar{Q}		34	56		
t_{PHL}	Clear	Q		20	27		ns
t_{PLH}		\bar{Q}		28	45		
$t_{wQ}(\text{min})$	A or B	Q		116	200		ns
t_{wQ}	A or B	Q	$C_{ext} = 1000 \text{ pF}, R_{ext} = 10 \text{ k}\Omega,$ $C_L = 15 \text{ pF}, R_L = 2 \text{ k}\Omega$	4	4.5	5	μ s

¶ t_{PLH} = propagation delay time, low-to-high-level output

t_{PHL} = propagation delay time, high-to-low-level output

t_{wQ} = width of pulse at output Q

NOTE 7: See General Information Section for load circuits and voltage waveforms.

TYPES SN54LS422, SN54LS423, SN74LS422, SN74LS423 RETRIGGERABLE MONOSTABLE MULTIVIBRATORS

TYPICAL APPLICATION DATA FOR 'LS422, 'LS423†

The basic output pulse width is essentially determined by the values of external capacitance and timing resistance. For pulse widths when $C_{ext} \leq 1000$ pF, use Figure 3, or may be defined as:

$$t_w \approx K \cdot R_T \cdot C_{ext}$$

When $C_{ext} \geq 1 \mu\text{F}$, the output pulse width is defined as:

$$t_w \approx 0.33 \cdot R_T \cdot C_{ext}$$

Where

K is multiplier factor, see Figure 4

R_T is in K ohms (internal or external timing resistance)

C_{ext} is in pF

t_w is in nanoseconds

For maximum noise immunity, system ground should be applied to the C_{ext} node, even though the C_{ext} node is already tied to the ground lead internally. Due to the timing scheme used by the 'LS422 and 'LS423, a switching diode is not required to prevent reverse biasing when using electrolytic capacitors.

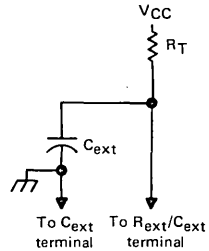

TIMING COMPONENT CONNECTIONS
FIGURE 2

'LS422, 'LS423 TYPICAL OUTPUT PULSE WIDTH vs EXTERNAL TIMING CAPACITANCE

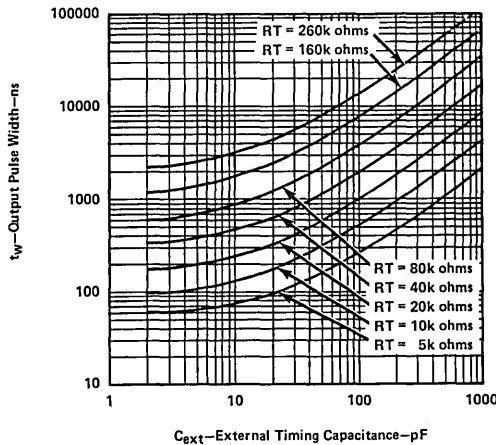

† This value of resistance exceeds the maximum recommended for use over the full temperature range of the SN54LS circuits.

FIGURE 3

3
TTL DEVICES

TYPES SN54LS422, SN54LS423, SN74LS422, SN74LS423
RETRIGGERABLE MONOSTABLE MULTIVIBRATORS

TYPICAL APPLICATION DATA FOR 'LS422, 'LS423 †

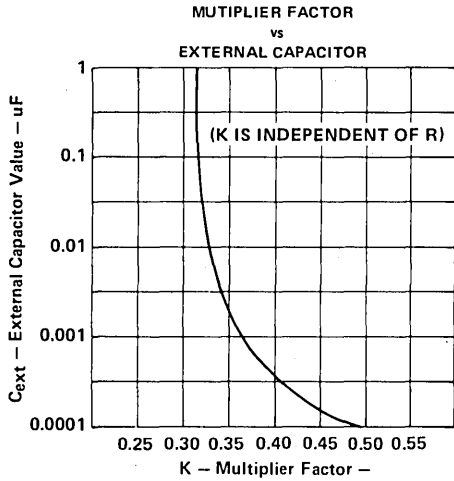

FIGURE 4

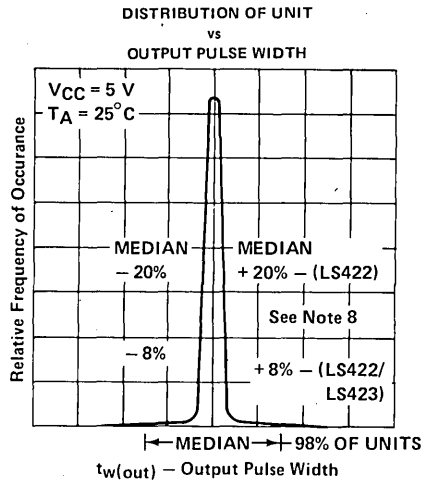

FIGURE 5

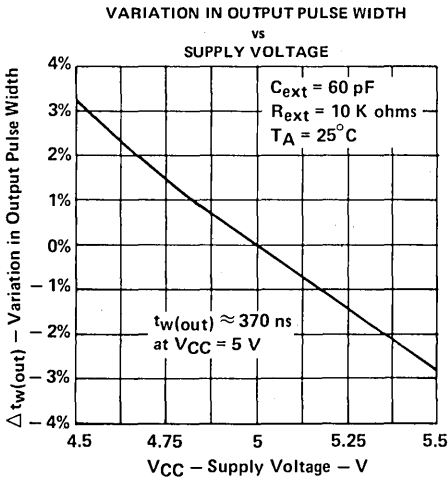

FIGURE 6

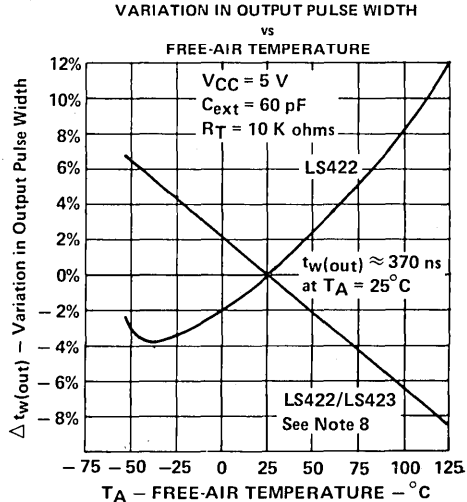

FIGURE 7

NOTE 8: For the LS422, the internal timing resistor, R_{int} was used. For the LS422/423, an external timing resistor was used for R_T .
† Data for temperatures below $0^\circ C$ and above $70^\circ C$ and for supply voltages below 4.75 V and above 5.25 V are applicable for SN54LS422 and SN54LS423 only.

TYPES SN54425, SN54426, SN74425, SN74426 QUADRUPLE BUS BUFFERS WITH 3-STATE OUTPUTS

REVISED DECEMBER 1983

- Quad Bus Buffers
- 3-State Outputs
- Separate Control for Each Channel

SN54425, SN54426 . . . J OR W PACKAGE
SN74425, SN74426 . . . J OR N PACKAGE
(TOP VIEW)

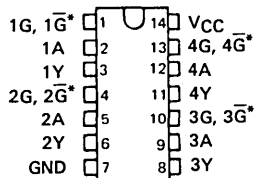

* \bar{G} on '425, G on '426

description

These bus buffers feature three-state outputs that, when enabled, have the low impedance characteristics of a TTL output with additional drive capability at high logic levels to permit driving heavily loaded bus lines without external pull-up resistors, when disabled, both output transistors are turned off presenting a high-impedance state to the bus so the output will act neither as a significant load nor as a driver. The '425 outputs are disabled when \bar{G} is high. The '426 outputs are disabled when G is low.

logic diagram (each gate)

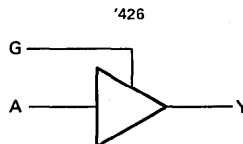
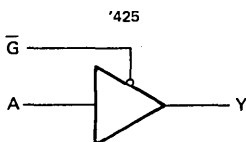

positive logic: $Y = A$

absolute maximum ratings over operating free-air temperature range (unless otherwise noted)

Supply voltage, V_{CC} (see Note 1)	7 V
Input voltage	5.5 V
Operating free-air temperature range: SN54'	-55°C to 125°C
SN74'	0°C to 70°C
Storage temperature range	-65°C to 150°C

NOTE 1: Voltage values are with respect to network ground terminal.

PRODUCTION DATA

This document contains information current as of publication date. Products conform to specifications per the terms of Texas Instruments standard warranty. Production processing does not necessarily include testing of all parameters.

TEXAS
INSTRUMENTS

POST OFFICE BOX 225012 • DALLAS, TEXAS 75265

3-1089

3

TTL DEVICES

TYPES SN54425, SN54426, SN74425, SN74426
 QUADRUPLE BUS BUFFERS WITH 3-STATE OUTPUTS

schematics (each gate)

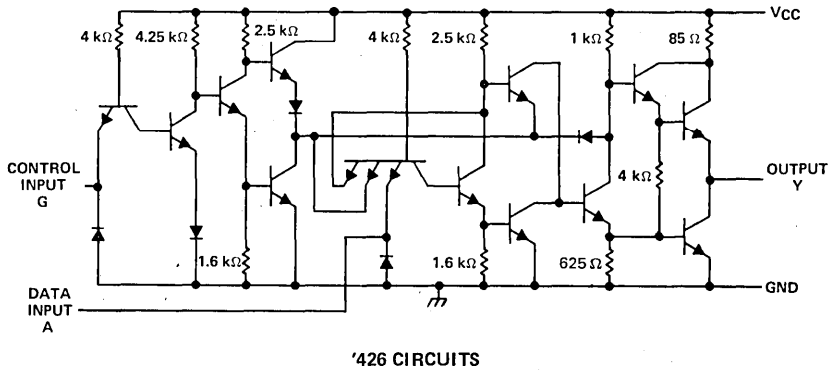
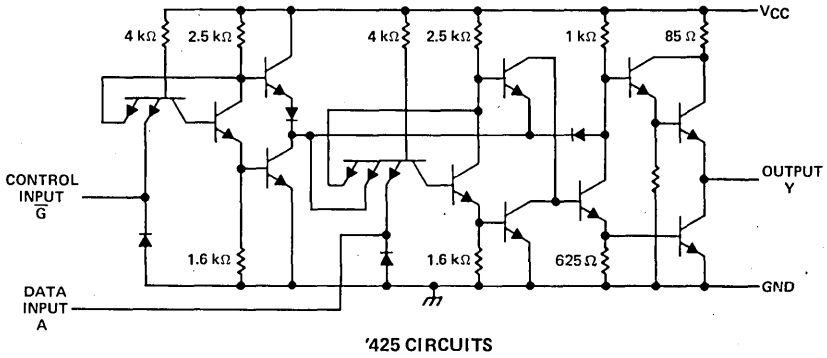

Resistor values shown are nominal.

3

TTL DEVICES

TYPES SN54425, SN54426, SN74425, SN74426 QUADRUPLE BUS BUFFERS WITH 3-STATE OUTPUTS

recommended operating conditions

	SN54425, SN54426			SN74425, SN74426			UNIT
	MIN	NOM	MAX	MIN	NOM	MAX	
V _{CC} Supply voltage	4.5	5	5.5	4.75	5	5.25	V
V _{IH} High-level input voltage	2			2			V
V _{IL} Low-level input voltage				0.8			V
I _{OH} High-level output current				-2			mA
I _{OL} Low-level output current				16			mA
T _A Operating free-air temperature	-55			125			°C

electrical characteristics over recommended operating free-air temperature range (unless otherwise noted)

PARAMETER	TEST CONDITIONS †		SN54425, SN54426			SN74425, SN74426			UNIT
			MIN	TYP‡	MAX	MIN	TYP‡	MAX	
V _{IK}	V _{CC} = MIN,	I _I = -12 mA	-1.5			-1.5			V
V _{OH}	V _{CC} = MIN, V _{IL} = 0.8 V	V _{IH} = 2 V, I _{OH} = -2 V I _{OH} = -5.2 V	2.4	3.3		2.4	3.1		V
V _{OL}	V _{CC} = MIN, I _{OL} = 16 mA	V _{IH} = 2 V, V _{IL} = 0.8 V	0.4			0.4			V
I _{OZ}	V _{CC} = MAX, V _{IL} = 0.8 V	V _{IH} = 2 V, V _O = 2.4 V V _O = 0.4 V	40			40			μA
I _I	V _{CC} = MAX,	V _I = 5.5 V	1			1			mA
I _{IH}	V _{CC} = MAX,	V _I = 2.4 V	40			40			μA
I _{IL}	V _{CC} = MAX,	V _I = 0.4 V	-1.6			-1.6			mA
I _{OS} §	V _{CC} = MAX		-30	-70		-28	-70		mA
I _{CC}	V _{CC} = MAX, (see Note 2)	'425	32	54		32	54		mA
		'426	36	62		36	62		

† For condition shown as MIN or MAX, use the appropriate value specified under recommended operating conditions.

‡ All typical values are at V_{CC} = 5 V, T_A = 25°C.

§ Not more than one output should be shorted at a time.

NOTE 2: Data inputs = 0 V; output control = 4.5 V for '425 and 0 V for '426.

switching characteristics, V_{CC} = 5 V, T_A = 25°C (see note 3)

PARAMETER	TEST CONDITIONS		SN54/74425			SN54/74426			UNIT
			MIN	TYP	MAX	MIN	TYP	MAX	
t _{PLH}	R _L = 400 Ω,	C _L = 50 pF	8	13		8	13		ns
t _{PHL}			12	18		12	18		ns
t _{PZH}			11	17		11	18		ns
t _{PZL}			16	25		16	25		ns
t _{PHZ}	R _L = 400 Ω,	C _L = 5 pF	5	8		10	16		ns
t _{PLZ}			7	12		12	18		ns

NOTE 3: See General Information Section for load circuits and voltage waveforms.

3

TTL DEVICES

TYPES SN54S436, SN54S437, SN74S436, SN74S437 LINE DRIVER/MEMORY DRIVER CIRCUITS

D2630, JANUARY 1981—REVISED APRIL 1985

MOS MEMORY INTERFACE

- Can Drive High-Impedance Loads
- Interchangeable with National DS16149 DS16179 Drivers
- High-Speed Switching
- Minimum Input Current Required
- Damping Output Resistor Reduces Transients

SN54S436, SN54S437 ... J OR W PACKAGE
SN74S436, SN74S437 ... D, J OR N PACKAGE

(TOP VIEW)

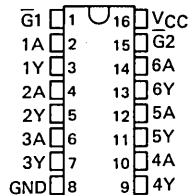

description

The SN54S436, SN54S437, SN74S436 and SN74S437 are monolithic integrated TTL-to-MOS drivers and interface circuits. The p-n-p input transistors use minimum current allowing increased fan-out to these drivers. Schottky-clamped transistor logic permits high-speed operation, minimum propagation time.

A small series damping resistor has been included in the design of the 'S436 to eliminate undesired output transient overshoot. Either enable, \bar{G} , when high, sets the outputs to the high level for MOS RAM refresh applications.

SN54S436, SN54S437 ... FK PACKAGE
SN74S436, SN74S437 ... FN PACKAGE

(TOP VIEW)

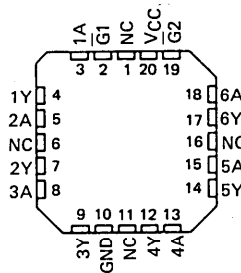

NC - No internal connection

FUNCTION TABLE

ENABLE INPUTS		INPUT	OUTPUT
$\bar{G}1$	$\bar{G}2$		
L	L	L	H
L	L	H	L
X	H	X	H
H	X	X	H

H = high level, L = low level, X = irrelevant

logic symbol

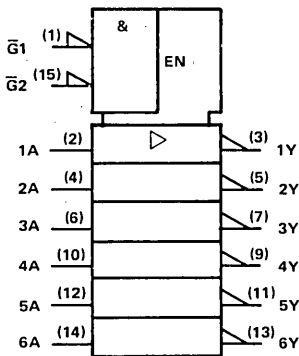

Pin numbers shown on logic notation are for D, J or N packages.

schematics of inputs and outputs

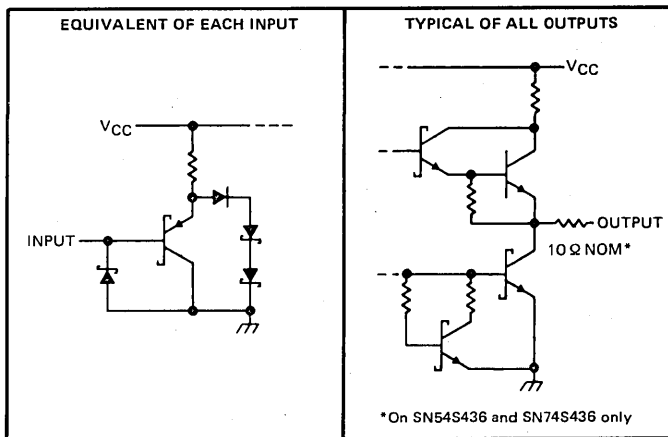

PRODUCTION DATA
This document contains information current as of publication date. Products conform to specifications per the terms of Texas Instruments standard warranty. Production processing does not necessarily include testing of all parameters.

**TEXAS
INSTRUMENTS**

POST OFFICE BOX 225012 • DALLAS, TEXAS 75265

3-1093

TYPES SN54S436, SN54S437, SN74S436, SN74S437

LINE DRIVER/MEMORY DRIVER CIRCUITS

absolute maximum ratings over operating free-air temperature range (unless otherwise noted)

Supply voltage, V_{CC} (see Note 1).....	7 V
Input voltage range.....	- 1.5 V to 7 V
Continuous total dissipation at (or below) 25° C free-air temperature (see Note 2)	
J package.....	1375 mW
N package.....	1150 mW
W package.....	1000 mW
Operating free-air temperature range: SN54S436, SN54S437.....	- 55° C to 125° C
SN74S436, SN74S437.....	0° C to 70° C
Storage temperature range.....	- 65° C to 150° C

NOTES 1: All voltage values are with respect to network ground terminal.

2: For operation above 25° C free-air temperature, derate as follows: J package, 11.0 mW/°C, N package, 9.2 mW/°C, W package, 8.0 mW/°C.

recommended operating conditions

		SN54S'			SN74S'			UNIT
		MIN	NOM	MAX	MIN	NOM	MAX	
V_{CC}	Supply voltage	4.5	5	5.5	4.75	5	5.25	V
V_{IH}	High-level input voltage	2			2			V
V_{IL}	Low-level input voltage	0.8			0.8			V
T_A	Operating free-air temperature	- 55	125		0	70		°C

electrical characteristics over recommended operating free-air temperature range (unless otherwise noted)

PARAMETER	TEST CONDITIONS	SN54LS165A			SN74LS165A			UNIT
		MIN	TYP†	MAX	MIN	TYP†	MAX	
V_{IK}	$V_{CC} = \text{MIN}$, $I_I = -18 \text{ mA}$	-0.75 - 1.2			-0.75 - 1.2			V
V_{OH}	$V_{CC} = \text{MIN}$, $I_{OH} = -10 \mu\text{A}$	3.4	4.3		3.5	4.3		V
	$V_{CC} = \text{MIN}$, $I_{OH} = -1 \text{ mA}$	'S436	2.4 3.5		'S436	2.6 3.5		
	'S437	2.5 3.5		'S437	2.7 3.5			
V_{OL}	$V_{CC} = \text{MIN}$, $I_{OL} = 10 \mu\text{A}$	0.25 0.4			0.25 0.35			V
	$V_{CC} = \text{MIN}$, $I_{OL} = 20 \text{ mA}$	'S436	0.6 1.1		'S436	0.6 1		
	'S437	0.4 0.5		'S437	0.4 0.5			
I_{OL}^*	$V_{CC} = \text{MIN}$, $V_O = 4.5 \text{ V}$, $V_I = 2 \text{ V}$ See Note 3	150 200			150 200			mA
I_{OS}^\ddagger	$V_{CC} = \text{MAX}$, $V_O = 0 \text{ V}$, See Note 3	- 100	- 250	- 400	- 100	- 250	- 400	mA
I_I	$V_{CC} = \text{MAX}$, $V_{IH} = 5.5 \text{ V}$	1			1			mA
I_{IH}	$V_{CC} = \text{MAX}$, $V_{IH} = 2.7 \text{ V}$	0.1 50			0.1 50			μA
I_{IL}	$V_{CC} = \text{MAX}$, $V_{IL} = 0.5 \text{ V}$	- 100 - 250			- 100 - 250			μA
I_{CC}	$V_{CC} = \text{MAX}$, G inputs at 0 V, All other inputs at 4.5 V	33 60			33 60			mA
	$V_{CC} = \text{MAX}$, All inputs at 0 V	14 20			14 20			

† All typical values are at $V_{CC} = 5 \text{ V}$, $T_A = 25^\circ \text{C}$.

‡ Not more than one output should be shorted at a time, and duration of the short-circuit should not exceed one second.

NOTE 3: When measuring output current on the SN54S437/SN74S437, a 10 Ω resistor should be placed in series with each output.

TYPES SN54S436, SN54S437, SN74S436, SN74S437 LINE DRIVER/MEMORY DRIVER CIRCUITS

switching characteristics, $V_{CC} = 5\text{ V}$, $T_A = 25^\circ\text{C}$, see note 3

PARAMETER		TEST CONDITIONS		MIN	TYP	MAX	UNIT
t_{AHL}	Delay time from A high to Y starting low	See Figure 1	$C_L = 50\text{ pF}$	4.5	7	ns	
			$C_L = 500\text{ pF}$	12	16		
t_{ALY}	Delay time from A low to Y starting high	See Figure 1	$C_L = 50\text{ pF}$	5	8	ns	
			$C_L = 500\text{ pF}$	11	16		
t_{GHH}	Delay time from G high to Y starting high	$R_L = 2\text{ k}\Omega$ to Gnd, See Figure 2	$C_L = 50\text{ pF}$,	10	18	ns	
t_{GLL}	Delay time from G low to Y starting low	$R_L = 2\text{ k}\Omega$ to V_{CC} , See Figure 3	$C_L = 50\text{ pF}$,	11	18	ns	
t_{THL}	Transition time, high-to-low-level output	See Figure 1	$C_L = 50\text{ pF}$	5	8	ns	
			$C_L = 500\text{ pF}$	15	30		
t_{TLH}	Transition time, low-to-high-level output	See Figure 1	$C_L = 50\text{ pF}$	6	9	ns	
			$C_L = 500\text{ pF}$	15	30		

NOTE 3: When measuring switching times on the SN54S437/SN74S437, a $10\text{ }\Omega$ resistor should be placed in series with each output.

PARAMETER MEASUREMENT INFORMATION

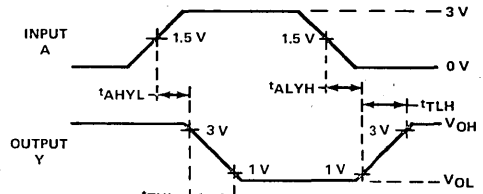
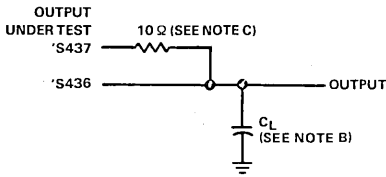

FIGURE 1

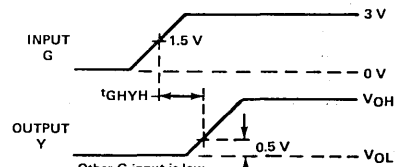
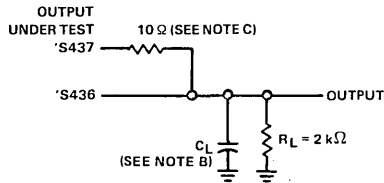

FIGURE 2

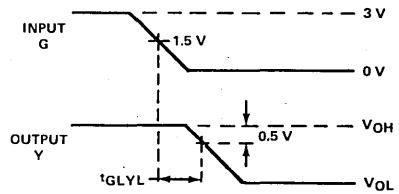
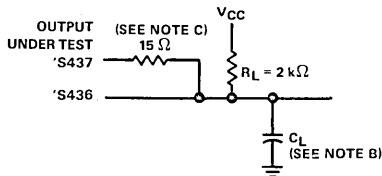

FIGURE 3

NOTES: A. Input pulses are supplied by a generator having the following characteristics: $PRR < 1\text{ MHz}$, $Z_{out} \approx 50\text{ }\Omega$, $t_r < 5\text{ ns}$.

B. C_L includes probe and jig capacitance.

C. This $15\text{-}\Omega$ resistor is required for testing the SN54S437/SN74S437, but it is internal to the SN54S436/SN74S436 and therefore an external resistor is not used for testing these devices.

3

TTL DEVICES

TYPES SN54LS440 THRU SN54LS444, SN54LS448 SN74LS440 THRU SN74LS444, SN74LS448 QUADRUPLE TRIDIRECTIONAL BUS TRANSCEIVERS

D2425, AUGUST 1979

- 3-Way Asynchronous Communication
- On-Chip Bus Selection Decoding
- Input Hysteresis Improves Noise Margin
- Choice of Open-Collector or 3-State Outputs

description

These bus transceivers are designed for asynchronous three-way communication between four-line data buses. They give the designer a choice of selecting inverting, noninverting, or a combination of inverting and noninverting data paths with either 3-state or open-collector outputs.

The S0 and S1 inputs select the bus from which data are to be transferred. The \bar{G} inputs enable the bus or buses to which data are to be transferred. The port for any bus selected for input and any other bus not enabled for output will be at high impedance including those of the open-collector devices.

The SN54LS440 through SN54LS444 and SN54LS448 are characterized for operation over the full military temperature range of -55°C to 125°C . The SN74LS440 through SN74LS444 and SN74LS448 are characterized for operation from 0°C to 70°C .

FUNCTION TABLE

INPUTS					TRANSFERS BETWEEN BUSES			
\bar{CS}	S1	S0	$\bar{G}A$	$\bar{G}B$	$\bar{G}C$	'LS440	'LS441	'LS444
						'LS442	'LS443	'LS448
H	X	X	X	X	X	None	None	None
X	H	H	X	X	X	None	None	None
X	X	X	H	H	H	None	None	None
X	L	L	X	H	H	None	None	None
X	L	H	H	X	H	None	None	None
X	H	L	H	H	X	None	None	None
L	L	L	X	L	L	$A \cdot B, A \cdot C$	$\bar{A} \cdot B, \bar{A} \cdot C$	$A \cdot B, \bar{A} \cdot C$
L	L	H	L	X	L	$B \cdot C, B \cdot A$	$\bar{B} \cdot C, \bar{B} \cdot A$	$B \cdot C, \bar{B} \cdot A$
L	H	L	L	L	X	$C \cdot A, C \cdot B$	$\bar{C} \cdot A, \bar{C} \cdot B$	$\bar{C} \cdot A, C \cdot B$
L	L	L	X	L	H	$A \cdot B$	$\bar{A} \cdot B$	$\bar{A} \cdot B$
L	L	H	H	X	L	$B \cdot C$	$\bar{B} \cdot C$	$B \cdot C$
L	H	L	L	H	X	$C \cdot A$	$\bar{C} \cdot A$	$\bar{C} \cdot A$
L	L	L	X	H	L	$A \cdot C$	$\bar{A} \cdot C$	$\bar{A} \cdot C$
L	L	H	L	X	H	$B \cdot A$	$\bar{B} \cdot A$	$\bar{B} \cdot A$
L	H	L	H	L	X	$C \cdot B$	$\bar{C} \cdot B$	$C \cdot B$

SN54LS' ... J PACKAGE
SN74LS' ... DW, J OR N PACKAGE
(TOP VIEW)

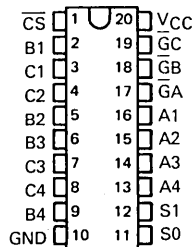

SN54LS' ... FK PACKAGE
SN74LS' ... FN PACKAGE
(TOP VIEW)

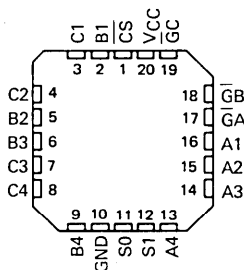

DEVICE	OUTPUT	LOGIC
'LS440	Open-Collector	True
'LS441	Open-Collector	Inverting
'LS442	3-State	True
'LS443	3-State	Inverting
'LS444	3-State	True/Inverting
'LS448	Open-Collector	True/Inverting



TTL DEVICES

PRODUCTION DATA
This document contains information current as of publication date. Products conform to specifications per the terms of Texas Instruments standard warranty. Production processing does not necessarily include testing of all parameters.

TEXAS
INSTRUMENTS

POST OFFICE BOX 225012 • DALLAS, TEXAS 75265

TYPES SN54LS440 THRU SN54LS444, SN54LS448,
SN74LS440 THRU SN74LS444, SN74LS448
QUADRUPLE TRIDIRECTIONAL BUS TRANSCEIVERS

logic symbols

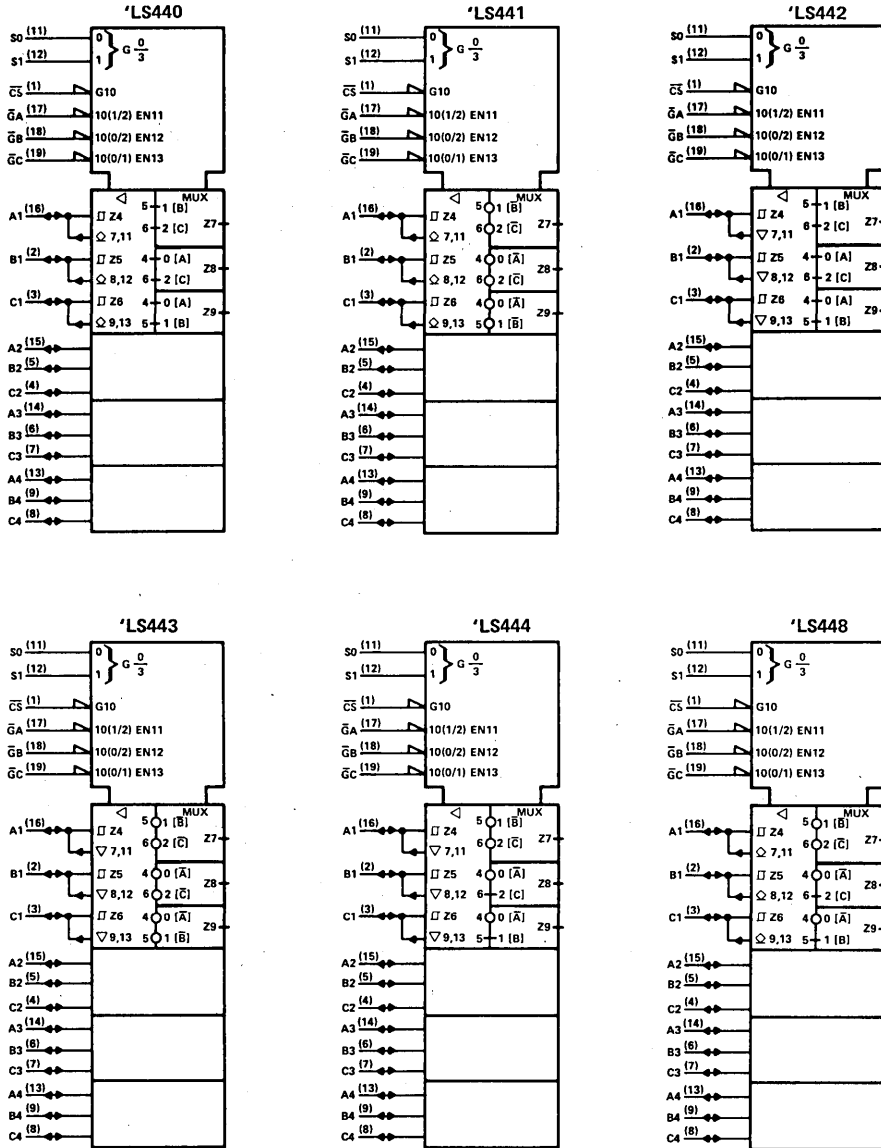

Pin numbers shown on logic notation are for DW, J or N packages.

3

TTL DEVICES

TYPES SN54LS440 THRU SN54LS444, SN54LS448, SN74LS440 THRU SN74LS444, SN74LS448 QUADRUPLE TRIDIRECTIONAL BUS TRANSCEIVERS

logic diagram (composite showing one of four transceivers from each type, positive logic)

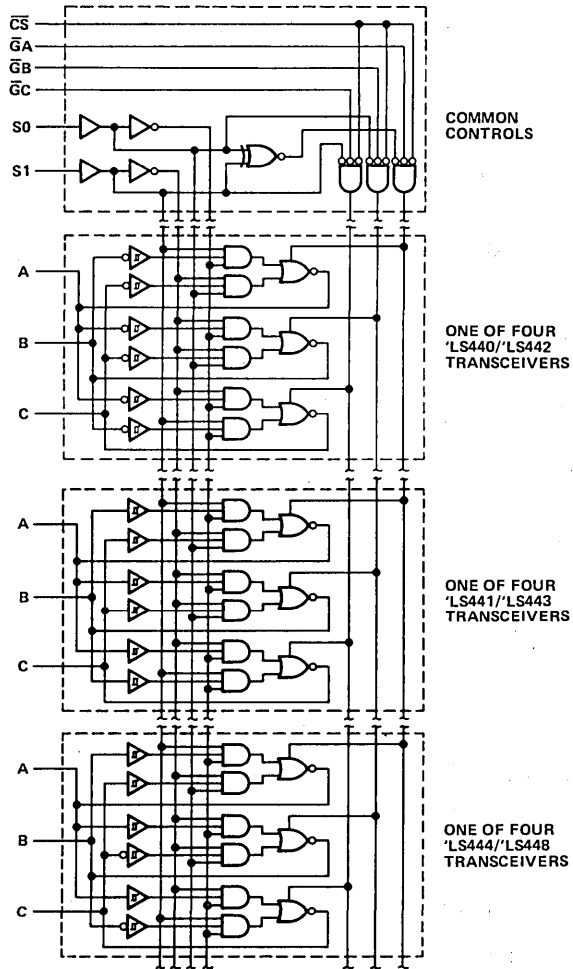

absolute maximum ratings over operating free-air temperature range (unless otherwise noted)

Supply voltage, V_{CC} (see Note 1)	7 V
Input voltage	7 V
Off-state output voltage	5.5 V
Operating free-air temperature range: SN54LS'	-55°C to 125°C
SN74LS'	0°C to 70°C
Storage temperature range	-65°C to 150°C

NOTE 1: Voltage values are with respect to network ground terminal.

**TYPES SN54LS440, SN54LS441, SN54LS448,
SN74LS440, SN74LS441, SN74LS448
QUAD TRIDIRECTIONAL BUS TRANSCEIVERS WITH OPEN-COLLECTOR OUTPUTS**

recommended operating conditions

	SN54LS440 SN54LS441 SN54LS448			SN74LS440 SN74LS441 SN74LS448			UNIT
	MIN	NOM	MAX	MIN	NOM	MAX	
Supply voltage, V_{CC} (see Note 1)	4.5	5	5.5	4.75	5	5.25	V
High-level output voltage, V_{OH}			5.5			5.5	V
Low-level output current, I_{OL}			12			24	mA
Operating free-air temperature, T_A	-55		125	0		70	C

NOTE 1: Voltage values are with respect to the network ground terminal.

electrical characteristics over recommended operating free-air temperature range (unless otherwise noted)

PARAMETER		TEST CONDITIONS†	SN54LS*		SN74LS*		UNIT
			MIN	TYP‡ MAX	MIN	TYP‡ MAX	
V_{IH}	High-level input voltage		2		2		V
V_{IL}	Low-level input voltage		0.5		0.6		V
V_{IK}	Input clamp voltage	$V_{CC} = \text{MIN}, I_I = -18 \text{ mA}$	-1.5		-1.5		V
	Hysteresis ($V_{T+} - V_{T-}$)	A, B, C input	0.1	0.4	0.2	0.4	V
I_{OH}	High-level output current	$V_{CC} = \text{MIN}, V_{IH} = 2 \text{ V}, V_{IL} = V_{ILmax}$	100		100		μA
V_{OL}	Low-level output voltage	$V_{CC} = \text{MIN}, V_{IH} = 2 \text{ V}, V_{IL} = V_{ILmax}$	0.25	0.4	0.25	0.4	V
					0.35	0.5	V
I_I	Input current at maximum input voltage	A, B, C input	0.1		0.1		mA
		All others	0.1		0.1		
I_{IH}	High-level input current	$V_{CC} = \text{MAX}, V_I = 2.7 \text{ V}$	20		20		μA
I_{IL}	Low-level input current	$V_{CC} = \text{MAX}, V_I = 0.4 \text{ V}$	-0.4		-0.4		mA
I_{CC}	Supply current	Outputs low	62	90	62	90	mA
		Outputs disabled	64	95	64	95	

† For conditions shown as MIN or MAX, use the appropriate value specified under recommended operating conditions.

‡ All typical values are at $V_{CC} = 5 \text{ V}, T_A = 25^\circ\text{C}$.

switching characteristics at $V_{CC} = 5 \text{ V}, R_L = 667 \Omega, C_L = 45 \text{ pF}, T_A = 25^\circ\text{C}$, see note 2

PARAMETER	FROM (INPUT)	TO (OUTPUT)	'LS440			'LS441			'LS448			UNIT
			MIN	TYP	MAX	MIN	TYP	MAX	MIN	TYP	MAX	
t_{PLH}	Propagation delay time, low-to-high level output	A	B	24	35	21	30	21	30	ns		
		A	C	24	35	21	30	21	30			
		B	A	24	35	21	30	21	30			
		B	C	24	35	21	30	24	35			
		C	A	24	35	21	30	21	30			
		C	B	24	35	21	30	24	35			
t_{PHL}	Propagation delay time, high-to-low level output	A	B	20	30	9	15	9	15	ns		
		A	C	20	30	9	15	9	15			
		B	A	20	30	9	15	9	15			
		B	C	20	30	9	15	20	30			
		C	A	20	30	9	15	9	15			
		C	B	20	30	9	15	20	30			
t_{PLH}	Propagation delay time, low-to-high level output	any \bar{G}	A, B, C	29	45	23	35	25	40	ns		
		S0, S1	A, B, C	33	50	27	40	26	40			
		\bar{CS}	A, B, C	31	45	26	40	25	40			
t_{PHL}	Propagation delay time, high-to-low level output	any \bar{G}	A, B, C	27	40	20	30	22	35	ns		
		S0, S1	A, B, C	32	50	26	40	27	40			
		\bar{CS}	A, B, C	28	45	21	30	22	35			

NOTE 2: See General Information Section for load circuits and voltage waveforms.

3 TTL DEVICES

**TYPES SN54LS442, SN54LS443, SN54LS444,
SN74LS442, SN74LS443, SN74LS444**
QUAD TRIDIRECTIONAL BUS TRANSCEIVERS WITH 3-STATE OUTPUTS

recommended operating conditions

	SN54LS442 SN54LS443 SN54LS444			SN74LS442 SN74LS443 SN74LS444			UNIT
	MIN	NOM	MAX	MIN	NOM	MAX	
Supply voltage, V_{CC} (see Note 1)	4.5	5	5.5	4.75	5	5.25	V
High-level output current, I_{OH}			-12			-15	mA
Low-level output current, I_{OL}			12			24	mA
Operating free-air temperature, T_A	-55		125	0		70	°C

NOTE 1: Voltage values are with respect to the network ground terminal.

electrical characteristics over recommended operating free-air temperature range (unless otherwise noted)

PARAMETER		TEST CONDITIONS†	SN54LS'			SN74LS'			UNIT
			MIN	TYP‡	MAX	MIN	TYP‡	MAX	
V_{IH}	High-level input voltage		2			2			V
V_{IL}	Low-level input voltage		0.5			0.6			V
V_{IK}	Input clamp voltage	$V_{CC} = \text{MIN}, I_I = -18 \text{ mA}$	-1.5			-1.5			V
	Hysteresis ($V_{T+} - V_{T-}$) A,B,C input	$V_{CC} = \text{MIN}$	0.1	0.4		0.2	0.4	V	
V_{OH}	High-level output voltage	$V_{CC} = \text{MIN}, V_{IH} = 2 \text{ V}, V_{IL} = V_{ILmax}$	$I_{OH} = -3 \text{ mA}$	2.4	3.4		2.4	3.4	V
			$I_{OH} = \text{MAX}$	2		2			
V_{OL}	Low-level output voltage	$V_{CC} = \text{MIN}, V_{IH} = 2 \text{ V}, V_{IL} = V_{ILmax}$	$I_{OL} = 12 \text{ mA}$	0.25	0.4		0.25	0.4	V
			$I_{OL} = 24 \text{ mA}$				0.35	0.5	
I_{OZH}	Off-state output current, high-level voltage applied	$V_{CC} = \text{MAX}, \overline{CS} \text{ at } 2 \text{ V}$			20			20	μA
I_{OZL}	Off-state output current, low-level voltage applied				-400			-400	
I_I	Input current at maximum input voltage	A, B, C Others	$V_{CC} = \text{MAX}$	$V_I = 5.5 \text{ V}$	0.1			0.1	mA
				$V_I = 7 \text{ V}$	0.1			0.1	
I_{IH}	High-level input current	$V_{CC} = \text{MAX}, V_I = 2.7 \text{ V}$			20			20	μA
I_{IL}	Low-level input current	$V_{CC} = \text{MAX}, V_I = 0.4 \text{ V}$			-0.4			-0.4	mA
I_{OS}	Short circuit output current	$V_{CC} = \text{MAX}$	-40		-225	-40		-225	mA
I_{CC}	Supply current	Outputs low		62	90		62	90	mA
		Outputs at Hi-Z		64	95		64	95	

† For conditions shown as MIN or MAX, use the appropriate value specified under recommended operating conditions.

‡ All typical values are at $V_{CC} = 5 \text{ V}, T_A = 25^\circ \text{C}$.

¶ Not more than one output should be shorted at a time, and duration of the short circuit should not exceed one second.

3
TTL DEVICES

TYPES SN54LS442, SN54LS443, SN54LS444, SN74LS442 THRU SN74LS443, SN74LS444 QUAD TRIDIRECTIONAL BUS TRANSCEIVERS WITH 3-STATE OUTPUTS

switching characteristics, $V_{CC} = 5\text{ V}$, $T_A = 25^\circ\text{C}$, see note 2

PARAMETER	FROM (INPUT)	TO (OUTPUT)	TEST CONDITIONS	'LS442			'LS443			'LS444			UNIT
				MIN	TYP	MAX	MIN	TYP	MAX	MIN	TYP	MAX	
t _{PLH} Propagation delay time, low-to-high level output	A	B	C _L = 45 pF, R _L = 667 Ω	10	14		9	14		9	14	ns	
	A	C		10	14		9	14		9	14		
	B	A		10	14		9	14		9	14		
	B	C		10	14		9	14		10	14		
	C	A		10	14		9	14		9	14		
	C	B		10	14		9	14		10	14		
t _{PHL} Propagation delay time, high-to-low level output	A	B			13	20		7	13		7	13	ns
	A	C			13	20		7	13		7	13	
	B	A			13	20		7	13		7	13	
	B	C			13	20		7	13		13	20	
	C	A			13	20		7	13		7	13	
	C	B			13	20		7	13		13	20	
t _{PZL} Output enable time to low level	Any \bar{G}	A, B, C		22	33		22	33		22	33	ns	
	S0 or S1	A, B, C		28	42		28	42		28	42		
	\bar{CS}	A, B, C		23	36		24	36		23	36		
t _{PZH} Output enable time to high level	\bar{G} , S \bar{CS}	A, B, C		21	32		20	32		24	32	ns	
t _{PLZ} Output disable time from low level	\bar{G} , S, \bar{CS}	A, B, C	C _L = 5 pF, R _L = 667 Ω	14	25		15	25		14	25	ns	
t _{PHZ} Output disable time from high level	\bar{G} , S, \bar{CS}	A, B, C		14	25		15	25		14	25	ns	

NOTE 2: See General Information Section for load circuits and voltage waveforms.

schematics of inputs and outputs

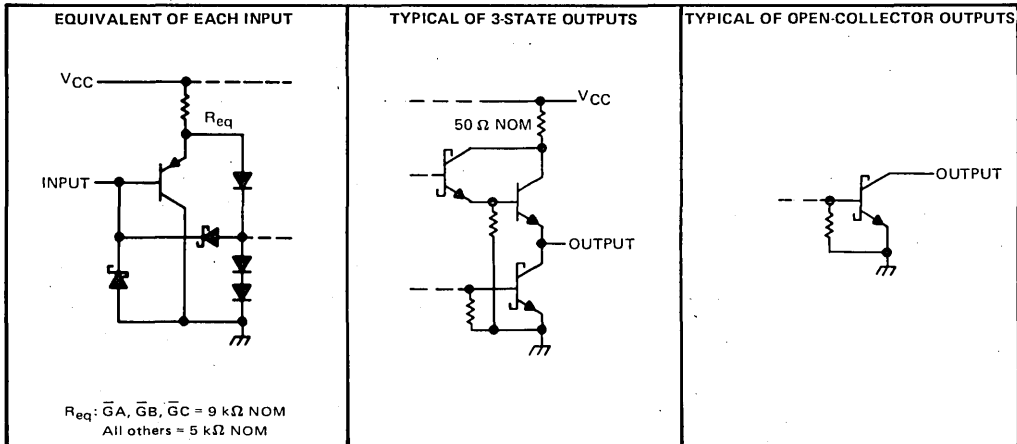

TYPES SN54LS445, SN74LS445 BCD-TO-DECIMAL DECODERS/DRIVERS

D2427, NOVEMBER 1977—REVISED DECEMBER 1983

FOR USE AS LAMP, RELAY, OR MOS DRIVERS

- Low-Voltage Version of SN54LS145/
SN74LS145
- Full Decoding of Input Logic
- SN74LS445 Has 80-mA Sink-Current
Capability
- All Outputs Are Off for Invalid BCD
Input Conditions
- Low Power Dissipation . . . 35 mW
Typical

logic

FUNCTION TABLE

NO.	INPUTS				OUTPUTS										
	D	C	B	A	0	1	2	3	4	5	6	7	8	9	
0	L	L	L	L	L	H	H	H	H	H	H	H	H	H	H
1	L	L	L	H	H	L	H	H	H	H	H	H	H	H	H
2	L	L	H	L	H	H	L	H	H	H	H	H	H	H	H
3	L	L	H	H	H	H	L	H	H	H	H	H	H	H	H
4	L	H	L	L	H	H	H	H	L	H	H	H	H	H	H
5	L	H	L	H	H	H	H	H	H	L	H	H	H	H	H
6	L	H	H	L	H	H	H	H	H	H	L	H	H	H	H
7	L	H	H	H	H	H	H	H	H	H	L	H	H	H	H
8	H	L	L	L	H	H	H	H	H	H	H	L	H	H	H
9	H	L	L	H	H	H	H	H	H	H	H	H	L	H	H
INVALID	H	L	H	L	H	H	H	H	H	H	H	H	H	H	H
	H	L	H	H	H	H	H	H	H	H	H	H	H	H	H
	H	L	L	L	H	H	H	H	H	H	H	H	H	H	H
	H	H	L	L	H	H	H	H	H	H	H	H	H	H	H
	H	H	H	L	H	H	H	H	H	H	H	H	H	H	H

H = high level (off), L = low level (on)

description

These monolithic BCD-to-decimal decoder/drivers consist of eight inverters and ten four-input NAND gates. The inverters are connected in pairs to make BCD input data available for decoding by the NAND gates. Full decoding of valid BCD input logic ensures that all outputs remain off for all invalid binary input conditions. These decoders feature high-performance, n-p-n output transistors designed for use as indicator/relay drivers or as open-collector logic-circuit drivers. Each of the output transistors will sink up to 80 milliamperes of current. Each input is one Series 54LS/74LS standard load. Inputs and outputs are entirely compatible for use with TTL logic circuits, and the outputs are compatible for interfacing with most MOS integrated circuits. Power dissipation is typically 35 milliwatts.

SN54LS445 . . . J PACKAGE
SN74LS445 . . . D, J OR N PACKAGE
(TOP VIEW)

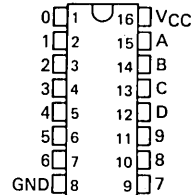

SN54LS445 . . . FK PACKAGE
SN74LS445 . . . FN PACKAGE
(TOP VIEW)

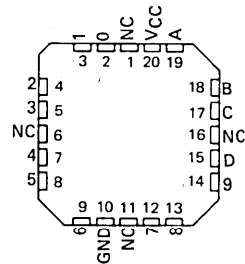

NC - No internal connection

logic diagram

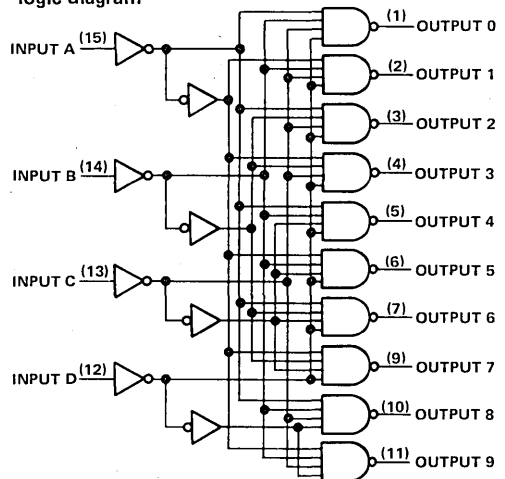

Pin numbers shown on logic notation are for D, J or N packages.

PRODUCTION DATA
This document contains information current as of publication date. Products conform to specifications per the terms of Texas Instruments standard warranty. Production processing does not necessarily include testing of all parameters.

**TEXAS
INSTRUMENTS**

POST OFFICE BOX 225012 • DALLAS, TEXAS 75265

3-1103

TTL DEVICES

TYPES SN54LS445, SN74LS445 BCD-TO-DECIMAL DECODERS/DRIVERS

absolute maximum ratings over operating free-air temperature range (unless otherwise noted)

Supply voltage, V_{CC} (see Note 1)	7 V
Input voltage	7 V
Operating free-air temperature range: SN54LS445	-55°C to 125°C
SN74LS445	0°C to 70°C
Storage temperature range	-65°C to 150°C

NOTE 1: Voltage values are with respect to network ground terminal.

recommended operating conditions

	SN54LS445			SN74LS445			UNIT
	MIN	NOM	MAX	MIN	NOM	MAX	
Supply voltage, V_{CC}	4.5	5	5.5	4.75	5	5.25	V
Off-state output voltage, $V_{O(off)}$	7						V
Operating free-air temperature, T_A	-55			125			°C

electrical characteristics over recommended operating free-air temperature range (unless otherwise noted)

PARAMETER	TEST CONDITIONS†	SN54LS445			SN74LS445			UNIT
		MIN	TYP‡	MAX	MIN	TYP‡	MAX	
V_{IH} High-level input voltage		2			2			V
V_{IL} Low-level input voltage		0.7			0.8			V
V_{IK} Input clamp voltage	$V_{CC} = \text{MIN}, I_I = -18 \text{ mA}$	-1.5			-1.5			V
$I_{O(off)}$ Off-state output current	$V_{CC} = \text{MIN}, V_{IH} = 2 \text{ V}, V_{IL} = V_{IL \text{ max}}, V_{OH} = 7 \text{ V}$	250			250			μA
$V_{O(on)}$ On-state output voltage	$V_{CC} = \text{MIN}, V_{IH} = 2 \text{ V}, V_{IL} = V_{IL \text{ max}}$	$I_{OL} = 12 \text{ mA}$	0.25	0.4	0.25	0.4	V	
		$I_{OL} = 24 \text{ mA}$			0.35	0.5		
		$I_{OL} = 80 \text{ mA}$			2.3	3		
I_I Input current at maximum input voltage	$V_{CC} = \text{MAX}, V_I = 7 \text{ V}$	0.1			0.1			mA
I_{IH} High-level input current	$V_{CC} = \text{MAX}, V_I = 2.7 \text{ V}$	20			20			μA
I_{IL} Low-level input current	$V_{CC} = \text{MAX}, V_I = 0.4 \text{ V}$	-0.4			-0.4			mA
I_{CC} Supply current	$V_{CC} = \text{MAX},$ See Note 2	7 13			7 13			mA

†For conditions shown as MIN or MAX, use the appropriate value specified under recommended operating conditions.

‡All typical values are at $V_{CC} = 5 \text{ V}, T_A = 25^\circ\text{C}$.

NOTE 2: I_{CC} is measured with all inputs grounded and outputs open.

switching characteristics, $V_{CC} = 5 \text{ V}, T_A = 25^\circ\text{C}$

PARAMETER	TEST CONDITIONS	MIN	MAX	UNIT
t_{PLH} Propagation delay time, low-to-high-level output	$C_L = 45 \text{ pF}, R_L = 665 \Omega,$ See Note 3	50		ns
t_{PHL} Propagation delay time, high-to-low-level output		50		ns

NOTE 3: See General Information Section for load circuits and voltage waveforms.

logic symbol

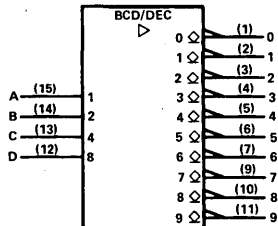

Pin numbers shown on logic notation are for D, J or N packages.

schematic of inputs and outputs

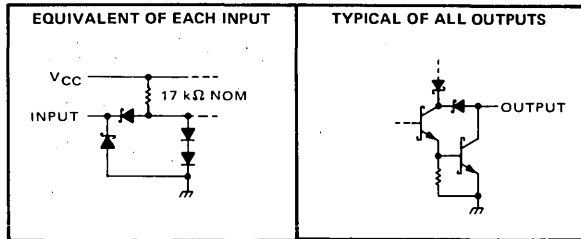

TYPES SN54LS446, SN54LS449, SN74LS446, SN74LS449 QUADRUPLE BUS TRANSCEIVERS WITH INDIVIDUAL DIRECTION CONTROLS

D2613, OCTOBER 1980 — REVISED DECEMBER 1983

SN54LS446, SN54LS449 ... J PACKAGE
SN74LS446, SN74LS449 ... D, J ORN PACKAGE
(TOP VIEW)

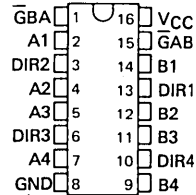

SN54LS446, SN54LS449 ... FK PACKAGE
SN74LS446, SN74LS449 ... FN PACKAGE
(TOP VIEW)

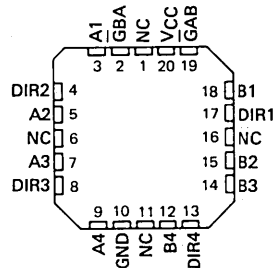

NC - No internal connection

- 3-State Outputs Drive Bus Lines Directly
- P-N-P Inputs Reduce DC Loading on Bus Line
- Hysteresis at Bus Inputs Improves Noise Margins
- Flow-Thru Data Pinout (B Bus Opposite A Bus)
- Choice of True ('LS449) and Inverting ('LS446)

description

These quadruple bus transceivers are designed for data transmission from individual lines of the A bus to individual lines of the B bus or the reverse, depending on the logic levels at the direction-control pins DIR1 through DIR4. These direction controls (one for each channel) allow maximum flexibility in timing. The enable inputs $\overline{\text{GBA}}$ and $\overline{\text{GAB}}$ can be used to disable the A or B outputs respectively, or to disable both buses for effective isolation.

The SN54LS446 and SN54LS449 are characterized for operation over the full military temperature range of -55°C to 125°C . The SN74LS446 and SN74LS449 are characterized for operation from 0°C to 70°C .

FUNCTION TABLE

ENABLE		DIRECTION DIR	OPERATION	
$\overline{\text{GBA}}$	$\overline{\text{GAB}}$		'LS446	'LS449
H	H	X	Isolation	Isolation
X	L	H	$\overline{\text{A}}$ data to B Bus	A data to B Bus
L	X	L	$\overline{\text{B}}$ data to A Bus	B data to A Bus
X	H	H	Isolation	Isolation
H	X	L	Isolation	Isolation

H = high level, L = low level, X = irrelevant

absolute maximum ratings over operating free-air temperature range (unless otherwise noted)

Supply voltage, V_{CC} (see Note 1)	7 V
Input voltage	7 V
Off-state output voltage	5.5 V
Operating free-air temperature range: SN54LS'	-55°C to 125°C
SN74LS'	0°C to 70°C
Storage temperature range	-65°C to 150°C

NOTE 1: Voltage values are with respect to the network ground terminal.

PRODUCTION DATA
This document contains information current as of publication date. Products conform to specifications per the terms of Texas Instruments standard warranty. Production processing does not necessarily include testing of all parameters.

TEXAS
INSTRUMENTS

POST OFFICE BOX 225012 • DALLAS, TEXAS 75265

3-1105

3

TTL DEVICES

TYPES SN54LS446, SN54LS449, SN74LS446, SN74LS449 QUADRUPLE BUS TRANSCEIVERS WITH INDIVIDUAL DIRECTION CONTROLS

logic symbols

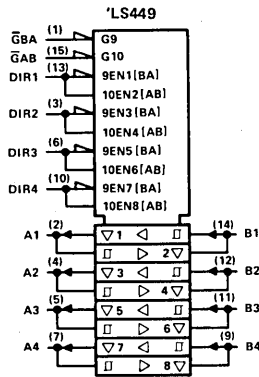
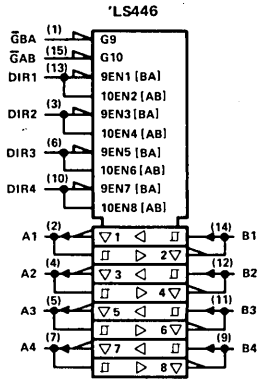

logic diagrams (positive logic)

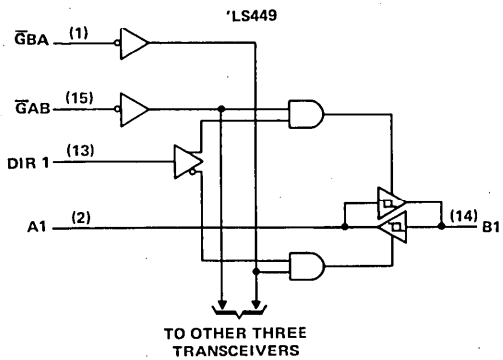
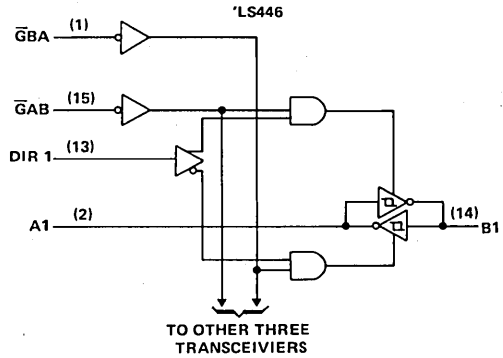

Pin numbers shown on logic notation are for D, J or N packages.

schematics of inputs and outputs

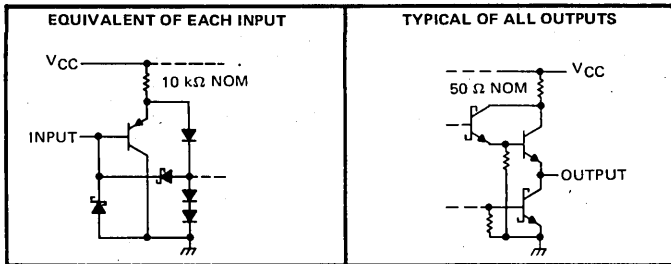

TYPES SN54LS446, SN54LS449, SN74LS446, SN74LS449 QUADRUPLE BUS TRANSCEIVERS WITH INDIVIDUAL DIRECTION CONTROLS

recommended operating conditions

PARAMETER	SN54LS446			SN74LS446			UNIT
	SN54LS449			SN74LS449			
	MIN	NOM	MAX	MIN	NOM	MAX	
Supply voltage, V_{CC} (see Note 1)	4.5	5	5.5	4.75	5	5.25	V
High-level output current, I_{OH}			-12			-15	mA
Low-level output current, I_{OL}			12			24	mA
Operating free-air temperature, T_A	-55		125	0		70	°C

NOTE 1: Voltage values are with respect to network ground terminal.

electrical characteristics over recommended operating free-air temperature range (unless otherwise noted)

PARAMETER	TEST CONDITIONS†	SN54LS446		SN74LS446		UNIT		
		SN54LS449		SN74LS449				
		MIN	TYP‡	MAX	MIN	TYP‡	MAX	
V_{IH} High-level input voltage		2		2		V		
V_{IL} Low-level input voltage		0.6		1.7		V		
V_{IK} Input clamp voltage	$V_{CC} = \text{MIN}, I_I = -18 \text{ mA}$	-1.5		-1.5		V		
Hysteresis ($V_{T+} - V_{T-}$), A or B input	$V_{CC} = \text{MIN}$	0.1	0.4	0.2	0.4	V		
V_{OH} High-level output voltage	$V_{CC} = \text{MIN}, V_{IH} = 2 \text{ V}, V_{IL} = V_{IL \text{ max}}$	$I_{OH} = -3 \text{ mA}$		2.4 3.4		V		
		$I_{OH} = \text{MAX}$		2				
V_{OL} Low-level output voltage	$V_{CC} = \text{MIN}, V_{IH} = 2 \text{ V}, V_{IL} = V_{IL \text{ max}}$	$I_{OL} = 12 \text{ mA}$		0.25 0.4		V		
		$I_{OL} = 24 \text{ mA}$		0.35 1.5				
I_{OZH} Off-state output current, high-level voltage applied	$V_{CC} = \text{MAX}, V_O = 2.7 \text{ V}, \bar{G}$ at 2 V,	20		20		μA		
I_{OZL} Off-state output current, low-level voltage applied	$V_{CC} = \text{MAX}, V_O = 0.4 \text{ V}, \bar{G}$ at 2 V,	-0.4		-0.4		mA		
I_I Input current at maximum input voltage	A or B \bar{G} AB or \bar{G} BA $V_{CC} = \text{MAX},$	$V_I = 5.5 \text{ V}$		0.1		mA		
		$V_I = 7 \text{ V}$		0.1				
I_{IH} High-level input current	$V_{CC} = \text{MAX}, V_I = 2.7 \text{ V}$	20		20		μA		
I_{IL} Low-level input current	$V_{CC} = \text{MAX}, V_I = 0.4 \text{ V}$	-0.4		-0.4		mA		
I_{OS} Short-circuit output current¶	$V_{CC} = \text{MAX}$	-40	-225	-40	-225	mA		
I_{CC} Total supply current	'LS446	$V_{CC} = \text{MAX},$ Outputs open	Outputs high	35	56	35	56	mA
			Outputs low	39	63	39	63	
	Outputs at Hi-Z		42	68	42	68		
	Outputs high		42	68	42	68		
	Outputs low		47	75	47	75		
	Outputs at Hi-Z		50	80	50	80		
'LS449	$V_{CC} = \text{MAX},$ Outputs open	Outputs high	35	56	35	56	mA	
		Outputs low	39	63	39	63		
Outputs at Hi-Z		42	68	42	68			
Outputs high		42	68	42	68			
Outputs low		47	75	47	75			
Outputs at Hi-Z		50	80	50	80			

† For conditions shown as MIN or MAX, use the appropriate value specified under recommended operating conditions.

‡ All typical values are at $V_{CC} = 5 \text{ V}, T_A = 25^\circ \text{C}$.

¶ Not more than one output should be shorted at a time, and duration of the short-circuit should not exceed one second.

TTL DEVICES

TYPES SN54LS446, SN54LS449, SN74LS446, SN74LS449
QUADRUPLE BUS TRANSCEIVERS WITH INDIVIDUAL DIRECTION CONTROLS

switching characteristics at $V_{CC} = 5\text{ V}$, $T_A = 25^\circ\text{C}$

PARAMETER	FROM (INPUT)	TO (OUTPUT)	TEST CONDITIONS	'LS446			'LS449			UNIT
				MIN	TYP	MAX	MIN	TYP	MAX	
t_{PLH} Propagation delay time, low-to-high-level output	A	B	$C_L = 45\text{ pF}$, $R_L = 667\ \Omega$, See Note 2	8	13	10	15	ns		
	B	A		8	13	10	15			
t_{PHL} Propagation delay time, high-to-low-level output	A	B		7	12	11	17	ns		
	B	A		7	12	11	17			
t_{pZL} Output enable time to low level	$\bar{G}BA$	A		24	40	21	35	ns		
	$\bar{G}AB$	B		24	40	21	35			
t_{pZH} Output enable time to high level	$\bar{G}BA$	A	15	25	18	30	ns			
	$\bar{G}AB$	B	15	25	18	30				
t_{pLZ} Output disable time from low level	$\bar{G}BA$	A	14	25	14	25	ns			
	$\bar{G}AB$	B	14	25	14	25				
t_{pHZ} Output disable time from high level	$\bar{G}BA$	A	10	15	10	15	ns			
	$\bar{G}AB$	B	10	15	10	15				

NOTE 2: See General Information Section for load circuits and voltage waveforms.

TYPES SN54LS447, SN74LS447 BCD-TO-SEVEN-DECODERS/DRIVERS

D2428, NOVEMBER 1977—REVISED DECEMBER 1983

- Low-Voltage Version of SN54LS247/SN74LS247
- Open-Collector Outputs Drive Indicators Directly
- Lamp-Test Provision
- Leading/Trailing Zero Suppression
- Lamp Intensity Modulation Capability

SN54LS447 ... J PACKAGE
SN74LS447 ... D, J OR N PACKAGE
(TOP VIEW)

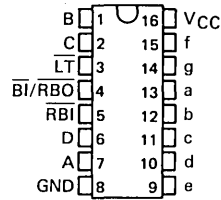

SN54LS447 ... FK PACKAGE
SN74LS447 ... FN PACKAGE
(TOP VIEW)

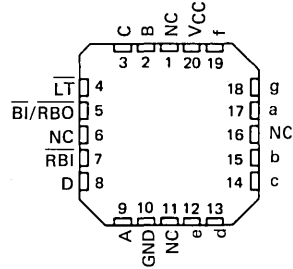

logic symbol

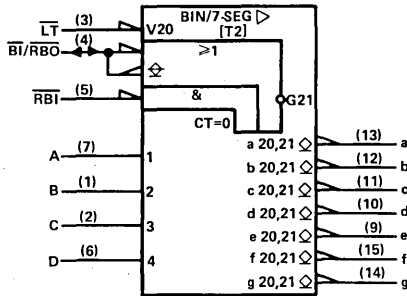

Pin numbers shown on logic notation are for D, J or N packages.

NC - No internal connection

FUNCTION TABLE

DECIMAL OR FUNCTION	INPUTS						BI/RBO [†]	OUTPUTS							NOTE
	LT	RBI	D	C	B	A		a	b	c	d	e	f	g	
0	H	H	L	L	L	L	H	ON	ON	ON	ON	ON	ON	OFF	OFF
1	H	X	L	L	L	H	H	OFF	ON	ON	OFF	OFF	OFF	OFF	OFF
2	H	X	L	L	H	L	H	ON	ON	OFF	ON	ON	OFF	ON	ON
3	H	X	L	L	H	H	H	ON	ON	ON	ON	OFF	OFF	ON	ON
4	H	X	L	H	L	L	H	OFF	ON	ON	OFF	OFF	OFF	ON	ON
5	H	X	L	H	L	H	H	ON	OFF	ON	ON	OFF	ON	ON	ON
6	H	X	L	H	H	L	H	ON	OFF	ON	ON	ON	ON	ON	ON
7	H	X	L	H	H	H	H	ON	ON	ON	OFF	OFF	OFF	OFF	OFF
8	H	X	H	L	L	L	H	ON	ON	ON	ON	ON	ON	ON	ON
9	H	X	H	L	L	H	H	ON	ON	ON	ON	OFF	ON	ON	ON
10	H	X	H	L	H	L	H	OFF	OFF	OFF	ON	ON	OFF	ON	ON
11	H	X	H	L	H	H	H	OFF	OFF	ON	ON	ON	OFF	OFF	ON
12	H	X	H	H	L	L	H	OFF	ON	OFF	OFF	OFF	OFF	ON	ON
13	H	X	H	H	L	H	H	ON	OFF	OFF	ON	OFF	ON	ON	ON
14	H	X	H	H	H	L	H	OFF	OFF	OFF	ON	ON	ON	ON	ON
15	H	X	H	H	H	H	H	OFF	OFF	OFF	OFF	OFF	OFF	OFF	OFF
BI	X	X	X	X	X	X	L	OFF	OFF	OFF	OFF	OFF	OFF	OFF	2
RBI	H	L	L	L	L	L	L	OFF	OFF	OFF	OFF	OFF	OFF	OFF	3
LT	L	X	X	X	X	X	H	ON	ON	ON	ON	ON	ON	ON	4

H = high level, L = low level, X = irrelevant

NOTES: 1. The blanking input (BI) must be open or held at a high logic level when output functions 0 through 15 are desired. The ripple-blanking input (RBI) must be open or high if blanking of a decimal zero is not desired.

2. When a low logic level is applied directly to the blanking input (BI), all segment outputs are off regardless of the level of any other input.

3. When ripple-blanking input (RBI) and inputs A, B, C, and D are at a low level with the lamp test input high, all segment outputs go off and the ripple-blanking output (RBO) goes to a low level (response condition).

4. When the blanking input/ripple blanking output (BI/RBO) is open or held high and a low is applied to the lamp-test input, all segment outputs are on.

[†]BI/RBO is wire-AND logic serving as blanking input (BI) and/or ripple-blanking output (RBO).

TEXAS
INSTRUMENTS

POST OFFICE BOX 225012 • DALLAS, TEXAS 75265

3-1109

3

TTL DEVICES

TYPES SN54LS447, SN74LS447 BCD-TO-SEVEN-SEGMENT DECODERS/DRIVERS

TYPE	DRIVER OUTPUTS				TYPICAL POWER DISSIPATION	PACKAGES
	ACTIVE LEVEL	OUTPUT CONFIGURATION	SINK CURRENT	MAX VOLTAGE		
SN54LS447	low	open-collector	12 mA	7 V	35 mW	J
SN74LS447	low	open-collector	24 mA	7 V	35 mW	J, N

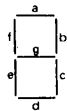

SEGMENT IDENTIFICATION

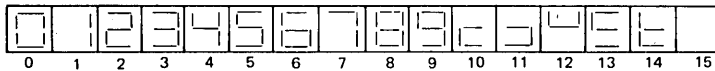

FONT TABLE T2 - NUMERICAL DESIGNATIONS AND RESULTANT DISPLAYS

absolute maximum ratings over operating free-air temperature range (unless otherwise noted)

Supply voltage, V_{CC} (see Note 1)	7 V
Input voltage	7 V
Peak output current ($t_w \leq 1$ ms, duty cycle $\leq 10\%$)	200 mA
Current forced into any output in the off state	1 mA
Operating free-air temperature range: SN54LS447	-55°C to 125°C
SN74LS447	0°C to 70°C
Storage temperature range	-65°C to 150°C

NOTE 1: Voltage values are with respect to network ground terminal.

recommended operating conditions

	SN54LS447			SN74LS447			UNIT
	MIN	NOM	MAX	MIN	NOM	MAX	
Supply voltage, V_{CC}	4.5	5	5.5	4.75	5	5.25	V
Off-state output voltage, $V_{O(off)}$	a thru g			7			V
On-state output current, $I_{O(on)}$	a thru g			12			24 mA
High-level output current, I_{OH}	$\overline{B1/RB0}$			-50			μA
Low-level output current, I_{OL}	$\overline{B1/RB0}$			1.6			3.2 mA
Operating free-air temperature, T_A	-55		125	0		70	$^\circ\text{C}$

3

TTL DEVICES

TYPES SN54LS447, SN74LS447
BCD-TO-SEVEN-SEGMENT DECODERS/DRIVERS

electrical characteristics over recommended operating free-air temperature range (unless otherwise noted)

PARAMETER		TEST CONDITIONS†	SN54LS447			SN74LS447			UNIT	
			MIN	TYP‡	MAX	MIN	TYP‡	MAX		
V _{IH}	High-level input voltage		2			2			V	
V _{IL}	Low-level input voltage				0.7				0.8 V	
V _{IK}	Input clamp voltage	V _{CC} = MIN, I _I = -18 mA			-1.5				-1.5 V	
V _{OH}	High-level output voltage	$\overline{\text{BI}}/\overline{\text{RBO}}$ V _{CC} = MIN, V _{IH} = 2 V, V _{IL} = V _{IL} max, I _{OH} = -50 μA	2.4	4.2		2.4	4.2		V	
V _{OL}	Low-level output voltage	$\overline{\text{BI}}/\overline{\text{RBO}}$ V _{CC} = MIN, V _{IH} = 2 V, V _{IL} = V _{IL} max			I _{OL} = 1.6 mA I _{OL} = 3.2 mA	0.25	0.4	0.25	0.4 0.35 0.5	
I _{O(off)}	Off-state output current	a thru g V _{CC} = MAX, V _{IH} = 2 V, V _{IL} = V _{IL} max, V _{O(off)} = 7 V					250		250 μA	
V _{O(on)}	On-state output voltage	a thru g V _{CC} = MAX, V _{IH} = 2 V, V _{IL} = V _{IL} max			I _{O(on)} = 12 mA I _{O(on)} = 24 mA	0.25	0.4	0.25	0.4 0.35 0.5	
I _I	Input current at maximum input voltage	V _{CC} = MAX, V _I = 7 V					0.1		0.1 mA	
I _{IH}	High-level input current	V _{CC} = MAX, V _I = 2.7 V					20		20 μA	
I _{IL}	Low-level input current	Any input except $\overline{\text{BI}}/\overline{\text{RBO}}$	V _{CC} = MAX, V _I = 0.4 V					-0.4	-0.4	mA
		$\overline{\text{BI}}/\overline{\text{RBO}}$						-1.2	-1.2	
I _{OS}	Short-circuit output current	$\overline{\text{BI}}/\overline{\text{RBO}}$ V _{CC} = MAX				-0.3	-2	-0.3	-2	mA
I _{CC}	Supply current	V _{CC} = MAX, See Note 2				7	13	7	13	mA

† For conditions shown as MIN or MAX, use the appropriate value specified under recommended operating conditions.

‡ All typical values are at V_{CC} = 5 V, T_A = 25°C.

NOTE 2: I_{CC} is measured with all outputs open and all inputs at 4.5 V.

switching characteristics, V_{CC} = 5 V, T_A = 25°C

PARAMETER		TEST CONDITIONS	MIN	TYP	MAX	UNIT
t _{off}	Turn-off time from A input	C _L = 15 pF, R _L = 665 Ω, See Note 4			100	ns
t _{on}	Turn-on time from A input				100	
t _{off}	Turn-off time from $\overline{\text{RBI}}$ input				100	
t _{on}	Turn-on time from $\overline{\text{RBI}}$ input				100	ns

NOTE 4: See General Information Section for load circuits and voltage waveforms.

3
TTL DEVICES

3

TTL DEVICES

TYPES SN54LS465 THRU SN54LS468, SN74LS465 THRU SN74LS468 OCTAL BUFFERS WITH 3-STATE OUTPUTS

D2631, JANUARY 1981—REVISED DECEMBER 1983

- Mechanically and Functionally Interchangeable With DM71/81LS95 thru DM71/81LS98
- P-N-P Inputs Reduce Bus Loading
- 3-State Outputs Rated at I_{OL} of 12 mA and 24 mA for 54LS and 74LS, Respectively

DEVICE	DATA PATH
'LS465	True
'LS466	Inverting
'LS467	True
'LS468	Inverting

description

These octal buffers utilize the latest low-power Schottky technology. The 'LS465 and 'LS466 have a two-input active-low AND enable gate controlling all eight data buffers. The 'LS467 and 'LS468 have two separate active-low enable inputs each controlling four data buffers. In either case, a high level on any \bar{G} places the affected outputs at high impedance.

schematics of inputs and outputs

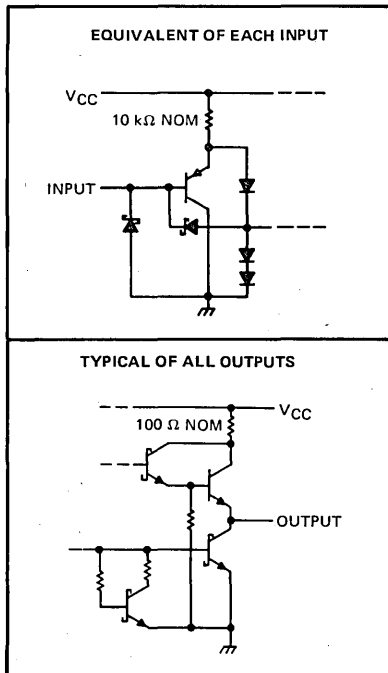

SN54LS465 AND SN54LS466 ... J PACKAGE
SN74LS465 AND SN74LS466 ... DW, J OR N PACKAGE

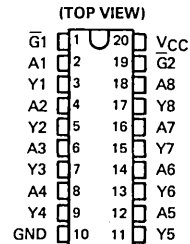

SN54LS465 AND SN54LS466 ... FK PACKAGE
SN74LS465 AND SN74LS466 ... FN PACKAGE

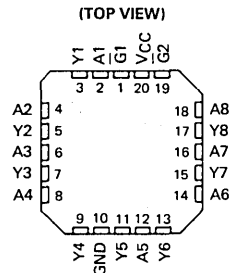

SN54LS467 AND SN54LS468 ... J PACKAGE
SN74LS467 AND SN74LS468 ... DW, J OR N PACKAGE

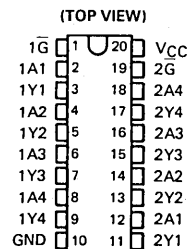

SN54LS467 AND SN54LS468 ... FK PACKAGE
SN74LS467 AND SN74LS468 ... FN PACKAGE

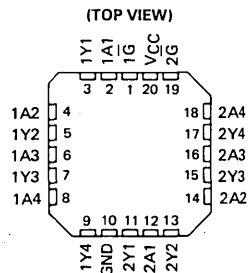

PRODUCTION DATA

This document contains information current as of publication date. Products conform to specifications per the terms of Texas Instruments standard warranty. Production processing does not necessarily include testing of all parameters.

TYPES SN54LS465 THRU SN54LS468, SN74LS465 THRU SN74LS468
 OCTAL BUFFERS WITH 3-STATE OUTPUTS

logic diagrams (positive logic)

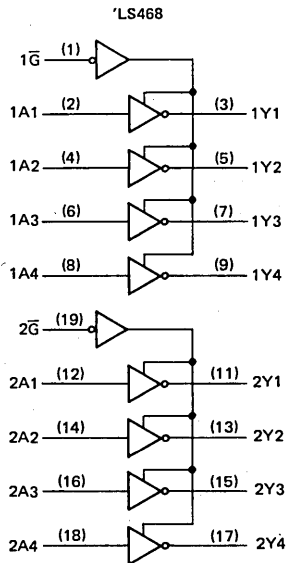
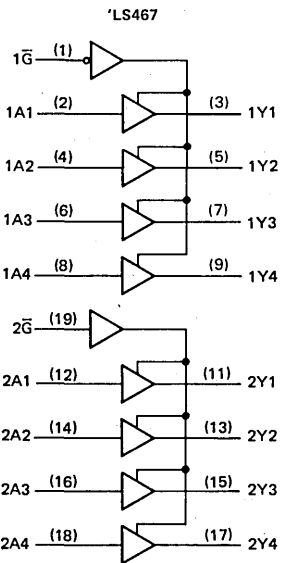
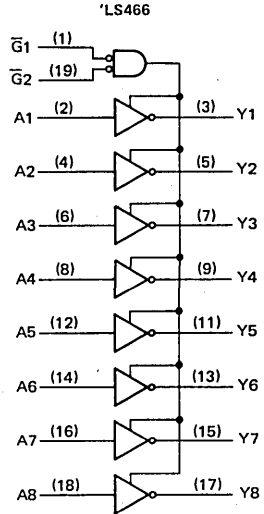
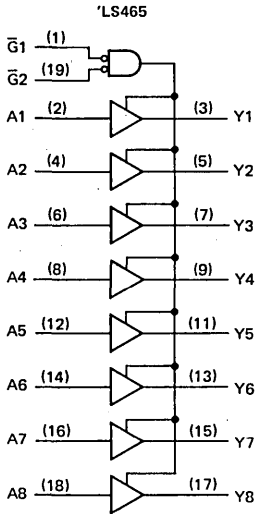

Pin numbers shown on logic notation are for DW, J or N packages.

3
 TTL DEVICES

TYPES SN54LS465 THRU SN54LS468, SN74LS465 THRU SN74LS468 OCTAL BUFFERS WITH 3-STATE OUTPUTS

logic symbols

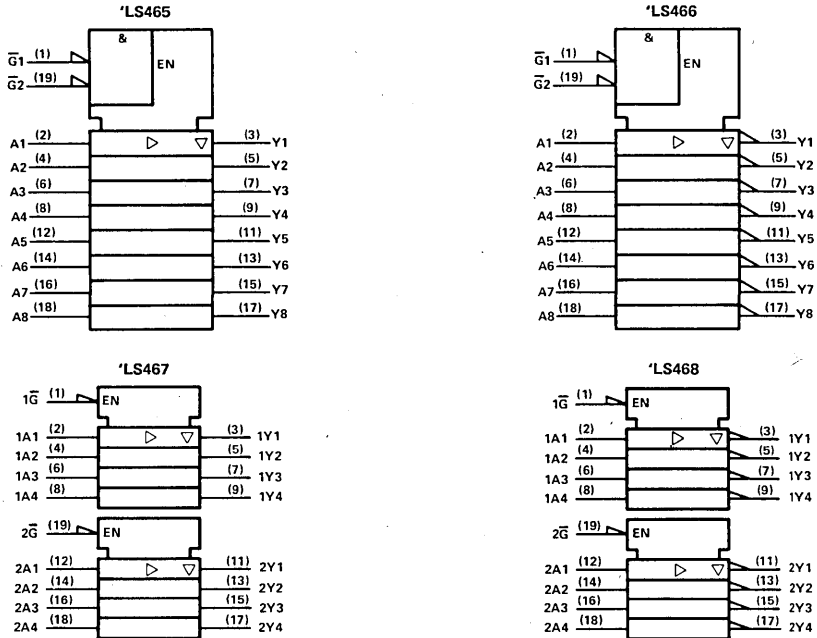

Pin numbers shown on logic notation are for DW, J or N packages.

absolute maximum ratings over operating free-air temperature range (unless otherwise noted)

Supply voltage, V_{CC} (see Note 1)	7 V
Input voltage	7 V
Off-state output voltage	5.5 V
Operating free-air temperature range: SN54LS465 thru SN54LS468	-55°C to 125°C
SN74LS465 thru SN74LS468	0°C to 70°C
Storage temperature range	-65°C to 150°C

NOTE 1: Voltage values are with respect to the network ground terminal.

recommended operating conditions

	SN54LS'			SN74LS'			UNIT
	MIN	NOM	MAX	MIN	NOM	MAX	
Supply voltage, V_{CC}	4.5	5	5.5	4.75	5	5.25	V
High-level output current, I_{OH}			-1			-2.6	mA
Low-level output current, I_{OL}			12			24	mA
Operating free-air temperature, T_A	-55		125	0		70	°C



TTL DEVICES

TYPES SN54LS465 THRU SN54LS468, SN74LS465, THRU SN74LS468 OCTAL BUFFERS WITH 3-STATE OUTPUTS

electrical characteristics over recommended operating free-air temperature range (unless otherwise noted)

PARAMETER	TEST CONDITIONS†	SN54LS*			SN74LS*			UNIT
		MIN	TYP‡	MAX	MIN	TYP‡	MAX	
V _{IH} High-level input voltage		2			2			V
V _{IL} Low-level input voltage		0.7			0.8			V
V _{IK} Input clamp voltage	V _{CC} = MIN, I _I = -18 mA	-1.5			-1.5			V
V _{OH} High-level output voltage	V _{CC} = MIN, V _{IH} = 2 V, I _{OH} = -1 mA	2.4 3.3						V
	V _{IL} = V _{IL} max, I _{OH} = -2.6 mA				2.4 3.1			
V _{OL} Low-level output voltage	V _{CC} = MIN, V _{IH} = 2 V, I _{OL} = 12 mA	0.25 0.4			0.25 0.4			V
	V _{IL} = V _{IL} max, I _{OL} = 24 mA				0.35 0.5			
I _{OZH} Off-state output current, high-level voltage applied	V _{CC} = MAX, V _{IH} = 2 V, V _O = 2.7 V, V _{IL} = V _{IL} max	20			20			μA
I _{OZL} Off-state output current, low-level voltage applied	V _{CC} = MAX, V _{IH} = 2 V, V _O = 0.4 V, V _{IL} = V _{IL} max	-20			-20			μA
I _I Input current at maximum input voltage	V _{CC} = MAX, V _I = 7 V	0.1			0.1			mA
I _{IH} High-level input current	V _{CC} = MAX, V _I = 2.7 V	20			20			μA
I _{IL} Low-level input current	V _{CC} = MAX, V _I = 0.4 V	-0.2			-0.2			mA
I _{OS} Short-circuit output current§	V _{CC} = MAX, V _O = 0 V	-30 -130			-30 -130			mA
I _{CC} Supply current	'LS465, 'LS467	V _{CC} = MAX	Outputs low	19	32	19	32	mA
			Outputs high	13	22	13	22	
			Output Hi-Z	22	37	22	37	
			Outputs low	14	23	14	23	
			Outputs high	6	10	6	10	
			Outputs Hi-Z	17	28	17	28	

† For conditions shown as MIN or MAX, use the appropriate value specified under recommended operating conditions.

‡ All typical values are at V_{CC} = 5 V, T_A = 25°C.

§ Not more than one output should be shorted at a time, and duration of the short-circuit should not exceed one second.

switching characteristics, V_{CC} = 5 V, T_A = 25°C, see note 2

PARAMETER	FROM (INPUT)	TO (OUTPUT)	TEST CONDITIONS	'LS465, 'LS467			'LS466, 'LS468			UNIT
				MIN	TYP	MAX	MIN	TYP	MAX	
t _{PLH}	A _i	Y _i	R _L = 667 Ω, C _L = 45 pF	9 15			7 12			ns
t _{PHL}	A _i	Y _i		12 18			9 15			ns
t _{PZH}	\bar{G} ↓	Y		25 40			25 40			ns
t _{PZL}	\bar{G} ↓	Y		29 45			29 45			ns
t _{PHZ}	\bar{G} ↑	Y	R _L = 667 Ω, C _L = 5 pF	25 40			25 40			ns
t _{PLZ}	\bar{G} ↑	Y		30 45			30 45			ns

NOTE 2: See General Information Section for load circuits and voltage waveforms.

TYPES SN54490, SN54LS490, SN74490, SN74LS490 DUAL 4-BIT DECADE COUNTERS

OCTOBER 1976—REVISED DECEMBER 1983

- Dual Versions of Popular SN5490A, SN54LS90, SN7490A, and SN74LS90 Counters
- Individual Clock, Direct Clear, and Set-to-9 Inputs for Each Decade Counter
- Dual Counters Can Significantly Improve System Densities as Package Count Can Be Reduced by 50%
- Maximum Count Frequency . . . 35 MHz Typical
- Buffered Outputs Reduce Possibility of Collector Commutation

SN54490, SN54LS490 . . . J OR W PACKAGE
SN74490 . . . J OR N PACKAGE
SN74LS490 . . . D, J OR N PACKAGE
(TOP VIEW)

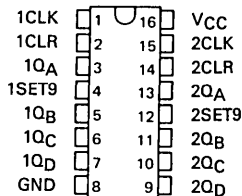

SN54LS490 . . . FK PACKAGE
SN74LS490 . . . FN PACKAGE
(TOP VIEW)

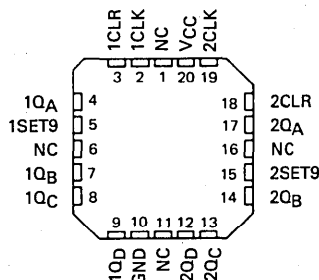

NC - No internal connection

description

Each of these monolithic circuits contains eight master-slave flip-flops and additional gating to implement two individual 4-bit decade counters in a single package. Each decade counter has individual clock, clear, and set-to-9 inputs. BCD count sequences of any length up to divide-by-100 may be implemented with a single '490 or 'LS490. Buffering on each output is provided to ensure that susceptibility to collector commutation is reduced significantly. All inputs are diode-clamped to reduce the effects of line ringing. The counters have parallel outputs from each counter stage so that submultiples of the input count frequency are available for system timing signals.

The SN54490 and SN54LS490 are characterized for operation over the full military temperature range of -55°C to 125°C; the SN74490 and SN74LS490 are characterized for use in industrial systems operating from 0°C to 70°C.

logic symbol

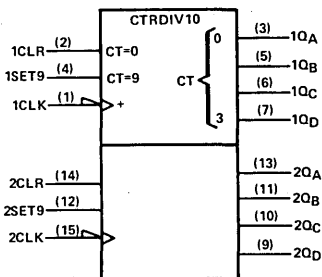

Pin numbers shown on logic notation are for D, J or N packages.
NC - No internal connection

BCD COUNT SEQUENCE (EACH COUNTER)

COUNT	OUTPUT			
	Q _D	Q _C	Q _B	Q _A
0	L	L	L	L
1	L	L	L	H
2	L	L	H	L
3	L	L	H	H
4	L	H	L	L
5	L	H	L	H
6	L	H	H	L
7	L	H	H	H
8	H	L	L	L
9	H	L	L	H

CLEAR/SET-TO-9 FUNCTION TABLE (EACH COUNTER)

INPUTS		OUTPUTS			
CLEAR	SET-TO-9	Q _A	Q _B	Q _C	Q _D
H	L	L	L	L	L
L	H	H	L	L	H
L	L	COUNT			

H = high level, L = low level

PRODUCTION DATA

This document contains information current as of publication date. Products conform to specifications per the terms of Texas Instruments standard warranty. Production processing does not necessarily include testing of all parameters.

TEXAS
INSTRUMENTS

POST OFFICE BOX 225012 • DALLAS, TEXAS 75265

3

TTL DEVICES

TYPES SN54490, SN54LS490, SN74490, SN74LS490
DUAL 4-BIT DECADE COUNTERS

schematics of inputs and outputs

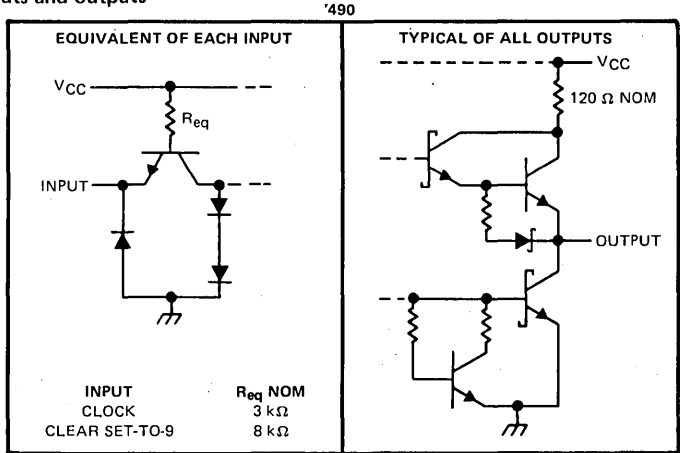

'LS490

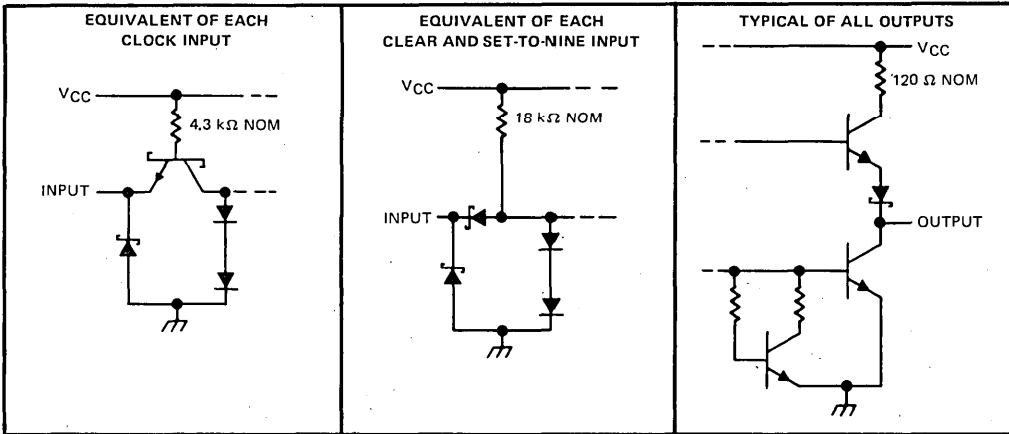

3 TTL DEVICES

TYPES SN54490, SN54LS490, SN74490, SN74LS490
DUAL 4-BIT DECADE COUNTERS

logic diagram (each counter)

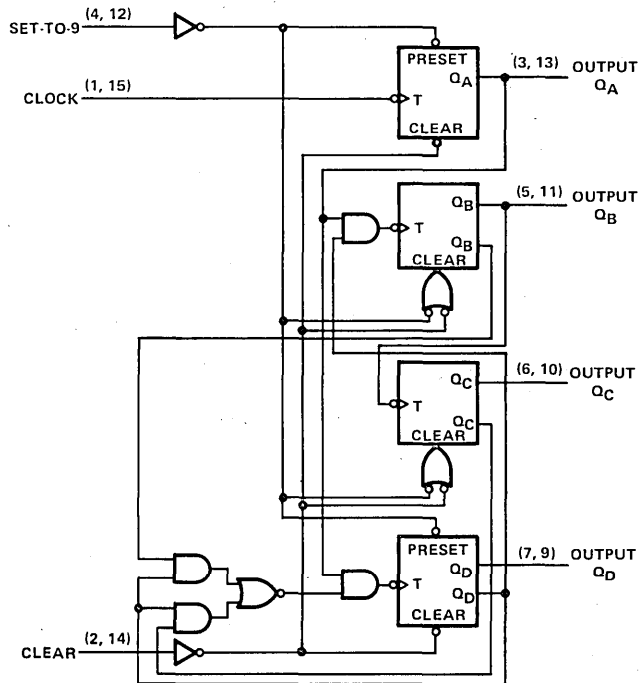

Pin numbers shown on logic notation are for D, J or N packages.

TYPES SN54490, SN74490 DUAL 4-BIT DECADE COUNTERS

absolute maximum ratings over operating free-air temperature range (unless otherwise noted)

Supply voltage, V_{CC} (see Note 1)	7 V
Input voltage	5.5 V
Operating free-air temperature range: SN54490	-55°C to 125°C
SN74490	0°C to 70°C
Storage temperature range	-65°C to 150°C

NOTE 1: Voltage values are with respect to network ground terminal.

recommended operating conditions

	SN54490			SN74490			UNIT
	MIN	NOM	MAX	MIN	NOM	MAX	
Supply voltage, V_{CC}	4.5	5	5.5	4.75	5	5.25	V
High-level output current, I_{OH}			-800			-800	μ A
Low-level output current, I_{OL}			16			16	mA
Count frequency, f_{count}	0		25	0		25	MHz
Pulse width, t_w (any input)		20			20		ns
Clear or set-to-9 inactive-state setup time, t_{su}		25 \downarrow			25 \downarrow		ns
Operating free-air temperature, T_A		-55	125		0	70	°C

\downarrow The arrow indicates that the falling edge of the clock pulse is used for reference.

electrical characteristics over recommended operating free-air temperature range (unless otherwise noted)

PARAMETER		TEST CONDITIONS [†]	MIN	TYP [‡]	MAX	UNIT
V_{IH}	High-level input voltage		2			V
V_{IL}	Low-level input voltage				0.8	V
V_{IK}	Input clamp voltage	$V_{CC} = \text{MIN}, I_I = -12 \text{ mA}$			-1.5	V
V_{OH}	High-level output voltage	$V_{CC} = \text{MIN}, V_{IH} = 2 \text{ V}, V_{IL} = 0.8 \text{ V}, I_{OH} = -800 \mu\text{A}$	2.4	3.4		V
V_{OL}	Low-level output voltage	$V_{CC} = \text{MIN}, V_{IH} = 2 \text{ V}, V_{IL} = 0.8 \text{ V}, I_{OL} = 16 \text{ mA}$		0.2	0.4	V
I_I	Input current at maximum input voltage	$V_{CC} = \text{MAX}, V_I = 5.5 \text{ V}$			1	mA
I_{IH}	High-level input current	Clear, set-to-9	$V_{CC} = \text{MAX}, V_I = 2.4 \text{ V}$		40	μ A
		Clock		80		
I_{IL}	Low-level input current	Clear, set-to-9	$V_{CC} = \text{MAX}, V_I = 0.4 \text{ V}$		-1	mA
		Clock		-3.2		
I_{OS}	Short-circuit output current [§]	$V_{CC} = \text{MAX}$	SN54490	-20	-57	mA
			SN74490	-18	-57	
I_{CC}	Supply current	$V_{CC} = \text{MAX}$, See Note 2		45	70	mA

[†]For conditions shown as MIN or MAX, use the appropriate value specified under recommended operating conditions.

[‡]All typical values are at $V_{CC} = 5 \text{ V}, T_A = 25^\circ\text{C}$.

[§]Not more than one output should be shorted at a time.

NOTE 2: I_{CC} is measured with all outputs open, both clear inputs grounded following momentary connection to 4.5 V, and all other inputs grounded.

9 TTL DEVICES

**TYPES SN54490, SN74490
DUAL 4-BIT DECADE COUNTERS**

switching characteristics, $V_{CC} = 5\text{ V}$, $T_A = 25^\circ\text{C}$

PARAMETER [†]	FROM (INPUT)	TO (OUTPUT)	TEST CONDITIONS	MIN	TYP	MAX	UNIT	
f_{max}	Clock	Q_A	$C_L = 15\text{ pF}$, $R_L = 400\ \Omega$, See Figure 1 and Note 3	25	35		MHz	
t_{PLH}	Clock	Q_A			12	20		ns
t_{PHL}					13	20		
t_{PLH}	Clock	Q_B, Q_D			24	39		ns
t_{PHL}					26	39		
t_{PLH}	Clock	Q_C			32	54		ns
t_{PHL}					36	54		
t_{PHL}	Clear	Any			24	39		ns
t_{PLH}	Set-to-9	Q_A, Q_D			24	39		ns
t_{PHL}		Q_B, Q_C			20	36		

[†] f_{max} ≡ maximum count frequency

t_{PLH} ≡ propagation delay time, low-to-high-level output

t_{PHL} ≡ propagation delay time, high-to-low-level output

NOTE 3: See General Information Section for load circuits and voltage waveforms.

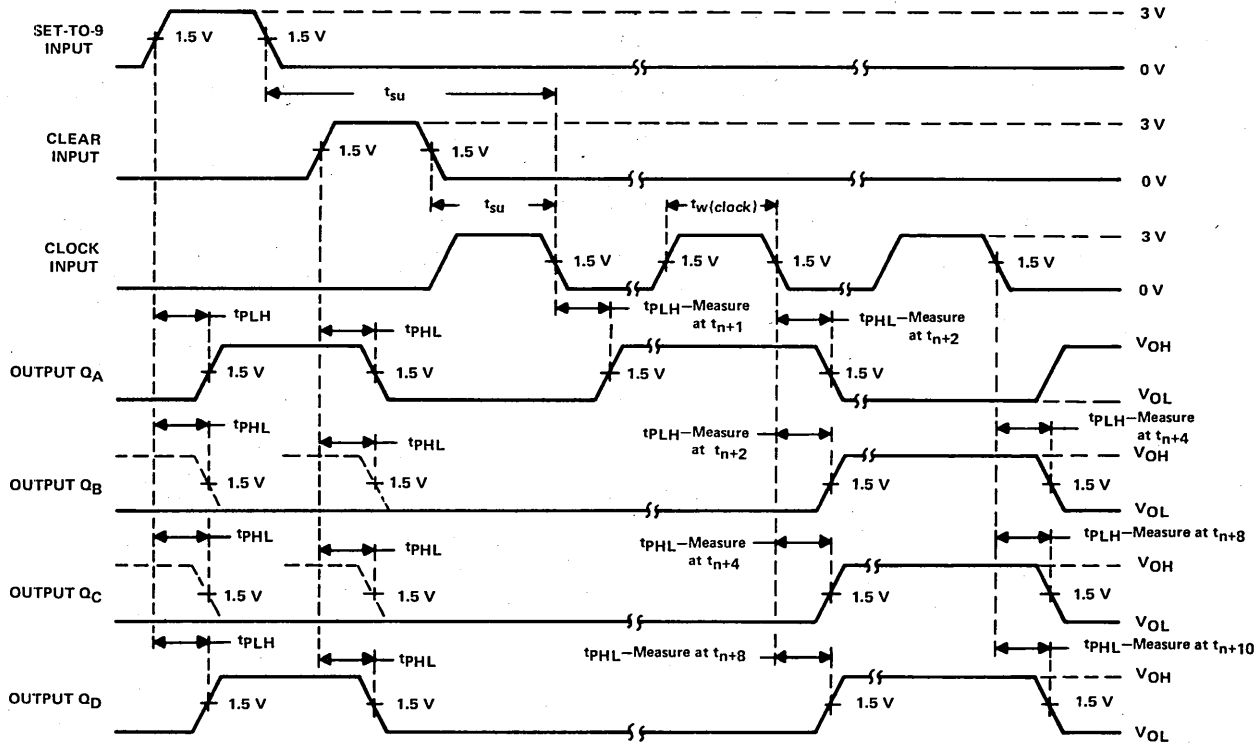

VOLTAGE WAVEFORMS

NOTES: A. Input pulses are supplied by a generator having the following characteristics: $t_r \leq 5$ ns, $t_f \leq 5$ ns, PRR = 1 MHz, duty cycle = 50%, $Z_{out} \approx 50$ ohms.

FIGURE 1

TYPES SN54LS490, SN74LS490 DUAL 4-BIT DECADE COUNTERS

absolute maximum ratings over operating free-air temperature range (unless otherwise noted)

Supply voltage, V_{CC} (see Note 1)	7 V
Clear and set-to-9 input voltage	7 V
Clock input voltage	5.5 V
Operating free-air temperature range: SN54LS490	-55°C to 125°C
SN74LS490	0°C to 70°C
Storage temperature range	-65°C to 150°C

NOTE 1: Voltage values are with respect to network ground terminal.

recommended operating conditions

	SN54LS490			SN74LS490			UNIT
	MIN	NOM	MAX	MIN	NOM	MAX	
Supply voltage, V_{CC}	4.5	5	5.5	4.75	5	5.25	V
High-level output current, I_{OH}			-400			-400	μ A
Low-level output current, I_{OL}			4			8	mA
Count frequency, f_{count}	0		25	0		25	MHz
Pulse width, t_w (any input)	20			20			ns
Clear or set-to-9 inactive-state setup time, t_{su}	25			25			ns
Operating free-air temperature, T_A	-55		125	0		70	°C

†The arrow indicates that the falling edge of the clock pulse is used for reference.

electrical characteristics over recommended operating free-air temperature range (unless otherwise noted)

PARAMETER		TEST CONDITIONS†	SN54LS490			SN74LS490			UNIT
			MIN	TYP‡	MAX	MIN	TYP‡	MAX	
V_{IH}	High-level input voltage		2			2			V
V_{IL}	Low-level input voltage				0.7			0.8	V
V_{IK}	Input clamp voltage	$V_{CC} = \text{MIN}, I_I = -18 \text{ mA}$			-1.5			-1.5	V
V_{OH}	High-level output voltage	$V_{CC} = \text{MIN}, V_{IH} = 2 \text{ V}, V_{IL} = V_{ILmax}$	2.5	3.4		2.7	3.4		V
V_{OL}	Low-level output voltage	$V_{CC} = \text{MIN}, V_{IH} = 2 \text{ V}, V_{IL} = V_{ILmax}$	$I_{OL} = 4 \text{ mA}$		0.25	0.4	0.25	0.4	V
			$I_{OL} = 8 \text{ mA}$				0.35	0.5	
I_I	Input current at maximum input voltage	Clear, set-to-9	$V_{CC} = \text{MAX}, V_I = 7 \text{ V}$				0.1	mA	
		Clock	$V_I = 5.5 \text{ V}$				0.2		
I_{IH}	High-level input current	Clear, set-to-9	$V_{CC} = \text{MAX}, V_I = 2.7 \text{ V}$			20	20	μ A	
		Clock				100	100		
I_{IL}	Low-level input current	Clear, set-to-9	$V_{CC} = \text{MAX}, V_I = 0.4 \text{ V}$			-0.4	-0.4	mA	
		Clock				-1.6	-1.6		
I_{OS}	Short-circuit output current§	$V_{CC} = \text{MAX}$	-20	-100	-20	-100	mA		
I_{CC}	Supply current	$V_{CC} = \text{MAX},$ See Note 2		15	26		15	26	mA

†For conditions shown as MIN or MAX, use the appropriate value specified under recommended operating conditions.

‡All typical values are at $V_{CC} = 5 \text{ V}, T_A = 25^\circ\text{C}$.

§Not more than one output should be shorted at a time, and duration of the short-circuit should not exceed one second.

NOTE 2: I_{CC} is measured with all outputs open, both clear inputs grounded following momentary connection to 4.5 V, and all other inputs grounded.

3

TTL DEVICES

TYPES SN54LS490, SN74LS490
DUAL 4-BIT DECADE COUNTERS

switching characteristics, $V_{CC} = 5\text{ V}$, $T_A = 25^\circ\text{C}$

PARAMETER [†]	FROM (INPUT)	TO (OUTPUT)	TEST CONDITIONS	MIN	TYP	MAX	UNIT
f_{\max}	Clock	Q_A	$C_L = 15\text{ pF}$, $R_L = 2\text{ k}\Omega$ See Figure 2 and Note 3	25	35		MHz
t_{PLH}	Clock	Q_A		12	20	ns	
t_{PHL}				13	20		
t_{PLH}	Clock	Q_B, Q_D		24	39	ns	
t_{PHL}				26	39		
t_{PLH}	Clock	Q_C		32	54	ns	
t_{PHL}				36	54		
t_{PHL}	Clear	Any		24	39	ns	
t_{PLH}	Set-to-9	Q_A, Q_D		24	39	ns	
t_{PHL}		Q_B, Q_C		20	36		

f_{\max} = maximum count frequency

t_{PLH} = Propagation delay time, low-to-high-level output

t_{PHL} = Propagation delay time, high-to-low-level output

NOTE 3: See General Information Section for load circuits and voltage waveforms.

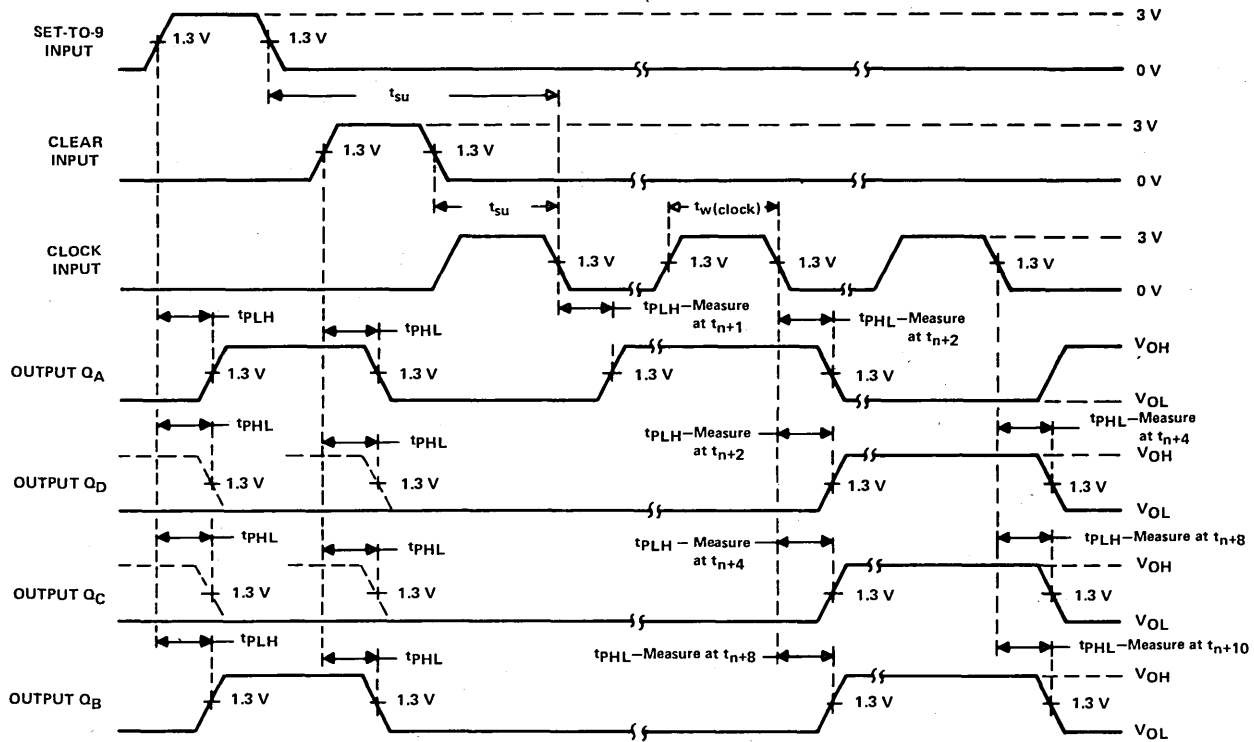

VOLTAGE WAVEFORMS

NOTES: A. Input pulses are supplied by a generator having the following characteristics: $t_r < 15$ ns, $t_f < 6$ ns, PRR = 1 MHz, duty cycle = 50%, $Z_{out} \approx 50$ ohms.

FIGURE 2



TTL DEVICES

TYPES SN54LS540, SN54LS541, SN74LS540, SN74LS541, OCTAL BUFFERS AND LINE DRIVERS WITH 3-STATE OUTPUTS

D2546, AUGUST 1979—REVISED APRIL 1985

- 3-State Outputs Drive Bus Lines or Buffer Memory Address Registers
- P-N-P Inputs Reduce D-C Loading
- Hysteresis at Inputs Improves Noise Margins
- Data Flow-thru Pinout (All Inputs on Opposite Side from Outputs)

description

These octal buffers and line drivers are designed to have the performance of the popular SN54LS240/SN74LS240 series and, at the same time, offer a pinout having the inputs and outputs on opposite sides of the package. This arrangement greatly enhances printed circuit board layout.

The three-state control gate is a 2-input NOR such that if either $\overline{G1}$ or $\overline{G2}$ are high, all eight outputs are in the high-impedance state.

The 'LS540 offers inverting data and the 'LS541 offers true data at the outputs.

The SN54LS540 and SN54LS541 are characterized for operation over the full military temperature range of -55°C to 125°C . The SN74LS540 and SN74LS541 are characterized for operation from 0°C to 70°C .

TYPE	RATED I_{OL} (SINK CURRENT)	RATED I_{OH} (SOURCE CURRENT)	TYPICAL POWER DISSIPATION (ENABLED)	
			'LS540	'LS541
SN54LS'	12 mA	-12 mA	92.5 mW	120 mW
SN74LS'	24 mA	-15 mA	92.5 mW	120 mW

schematics of inputs and outputs

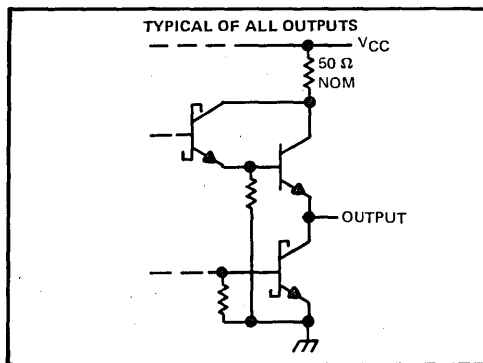
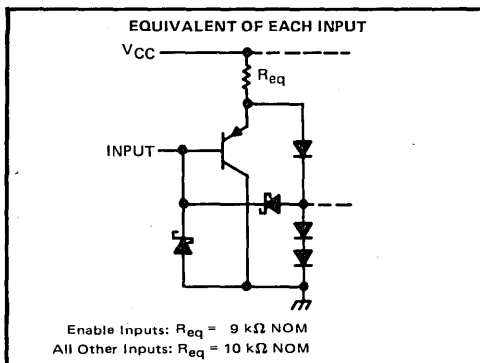

SN54LS540, SN54LS541 ... J PACKAGE
SN74LS540, SN74LS541 ... DW, J OR N PACKAGE
(TOP VIEW)

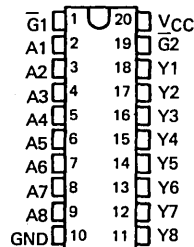

SN54LS540, SN54LS541 ... FK PACKAGE
SN74LS540, SN74LS541 ... FN PACKAGE
(TOP VIEW)

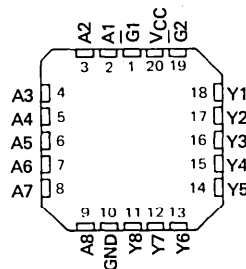

PRODUCTION DATA
This document contains information current as of publication date. Products conform to specifications per the terms of Texas Instruments standard warranty. Production processing does not necessarily include testing of all parameters.

**TEXAS
INSTRUMENTS**

POST OFFICE BOX 225012 • DALLAS, TEXAS 75265

TTL DEVICES

TYPES SN54LS540, SN54LS541, SN74LS540, SN74LS541 OCTAL BUFFERS AND LINE DRIVERS WITH 3-STATE OUTPUTS

logic symbols

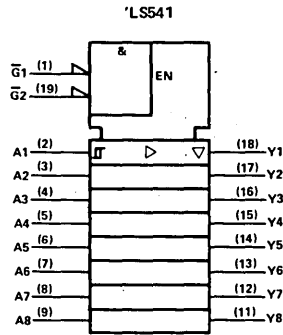
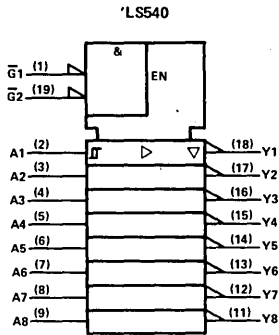

logic diagram (positive logic)

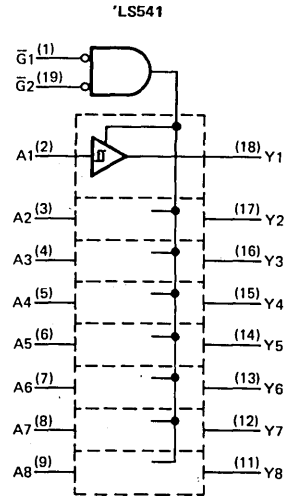
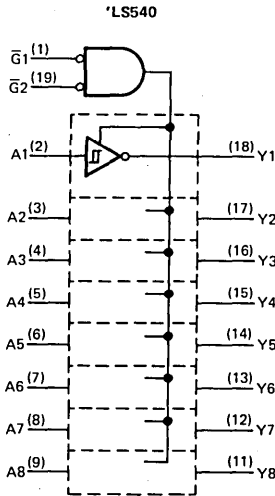

Pin numbers shown on logic notation are for DW, J or N packages.

absolute maximum ratings over operating free-air temperature range (unless otherwise noted)

Supply voltage, V_{CC} (see Note 1)	7 V
Input voltage	7 V
Operating free-air temperature range: SN54LS540, SN54LS541	-55°C to 125°C
SN74LS540, SN74LS541	0°C to 70°C
Storage temperature range	-65°C to 150°C

NOTE 1: Voltage values are with respect to the network ground terminal.

3 TTL DEVICES

TYPES SN54LS540, SN54LS541, SN74LS540, SN74LS541 OCTAL BUFFERS AND LINE DRIVERS WITH 3-STATE OUTPUTS

recommended operating conditions

PARAMETER	SN54LS*			SN74LS*			UNIT
	MIN	NOM	MAX	MIN	NOM	MAX	
Supply voltage, V_{CC} (see Note 1)	4.5	5	5.5	4.75	5	5.25	V
High-level output current, I_{OH}			-12			-15	mA
Low-level output current, I_{OL}			12			24	mA
Operating free-air temperature, T_A	-55		125	0		70	°C

NOTE 1: Voltage values are with respect to network ground terminal.

electrical characteristics over recommended operating free-air temperature range (unless otherwise noted)

PARAMETER	TEST CONDITIONS†	SN54LS*			SN74LS*			UNIT
		MIN	TYP‡	MAX	MIN	TYP‡	MAX	
V_{IH} High-level input voltage		2			2		V	
V_{IL} Low-level input voltage				0.5			0.6	
V_{IK} Input clamp voltage	$V_{CC} = \text{MIN}, I_I = -18 \text{ mA}$			-1.5			-1.5	
Hysteresis ($V_{T+} - V_{T-}$)	$V_{CC} = \text{MIN}$	0.2	0.4		0.2	0.4	V	
V_{OH} High-level output voltage	$V_{CC} = \text{MIN}, V_{IH} = 2 \text{ V}, V_{IL} = V_{IL \text{ max}}, I_{OH} = -3 \text{ mA}$	2.4	3.4		2.4	3.4	V	
	$V_{CC} = \text{MIN}, V_{IH} = 2 \text{ V}, V_{IL} = 0.5 \text{ V}, I_{OH} = \text{MAX}$	2			2			
V_{OL} Low-level output voltage	$V_{CC} = \text{MIN}, V_{IH} = 2 \text{ V}, V_{IL} = V_{IL \text{ max}}, I_{OL} = 12 \text{ mA}$		0.25	0.4		0.25	0.4	
	$V_{CC} = \text{MIN}, V_{IH} = 2 \text{ V}, V_{IL} = V_{IL \text{ max}}, I_{OL} = 24 \text{ mA}$					0.35	0.5	
I_{OZH} Off-state output current, high-level voltage applied	$V_{CC} = \text{MAX}, V_{IH} = 2 \text{ V}, V_{IL} = V_{IL \text{ max}}, V_O = 2.7 \text{ V}$			20			20	
I_{OZL} Off-state output current, low-level voltage applied	$V_{CC} = \text{MAX}, V_{IH} = 2 \text{ V}, V_{IL} = V_{IL \text{ max}}, V_O = 0.4 \text{ V}$			-20			-20	
I_I Input current at maximum input voltage	$V_{CC} = \text{MAX}, V_I = 7 \text{ V}$			0.1			0.1	
I_{IH} High-level input current, any input	$V_{CC} = \text{MAX}, V_I = 2.7 \text{ V}$			20			20	
I_{IL} Low-level input current	$V_{CC} = \text{MAX}, V_I = 0.4 \text{ V}$			-0.2			-0.2	
I_{OS} Short-circuit output current*	$V_{CC} = \text{MAX}$	-40		-225	-40		-225	
I_{CC} Supply current	Outputs high	$V_{CC} = \text{MAX},$ Outputs open	'LS540	13	25	13	25	mA
			'LS541	18	32	18	32	
	Outputs low		'LS540	24	45	24	45	
	'LS541		30	52	30	52		
	All outputs disabled		'LS540	30	52	30	52	
'LS541	32	55	32	55				

† For conditions shown as MIN or MAX, use the appropriate value specified under recommended operating conditions.

‡ All typical values are at $V_{CC} = 5 \text{ V}, T_A = 25^\circ \text{C}$.

* Not more than one output should be shorted at a time, and duration of the short-circuit should not exceed one second.

switching characteristics, $V_{CC} = 5 \text{ V}, T_A = 25^\circ \text{C}$

PARAMETER	TEST CONDITIONS	'LS540			'LS541			UNIT
		MIN	TYP	MAX	MIN	TYP	MAX	
t_{PLH} Propagation delay time, low-to-high-level output	$C_L = 45 \text{ pF}, R_L = 667 \Omega,$ See Note 2		9	15		9	15	ns
t_{PHL} Propagation delay time, high-to-low-level output			9	15		10	18	ns
t_{PZL} Output enable time to low level			25	38		25	38	ns
t_{PZH} Output enable time to high level	$C_L = 5 \text{ pF}, R_L = 667 \Omega,$ See Note 2		15	25		20	32	ns
t_{PLZ} Output disable time from low level			10	18		10	18	ns
t_{PHZ} Output disable time from high level			15	25		18	29	ns

NOTE 2: See General Information Section for load circuits and voltage waveforms.

3 TTL DEVICES

8-BIT SHIFT REGISTERS WITH INPUT LATCHES AND 3-STATE OUTPUT

TYPES SN54LS589, SN74LS589

REVISED DECEMBER 1983

- 8-Bit Parallel Storage Register Inputs
- Shift Register has Direct Overriding Load and Power-Up Clear
- Guaranteed Shift Frequency . . . DC to 20 MHz

description

The 'LS589 comes in a 16-pin package and consists of an 8-bit storage latch feeding a parallel-in, serial-out 8-bit shift register with 3-state outputs. Both the storage register and shift register have positive-edge triggered clocks. The shift register has a direct load (from storage) input.

SN54LS589 . . . J PACKAGE
SN74LS589 . . . J OR N PACKAGE
(TOP VIEW)

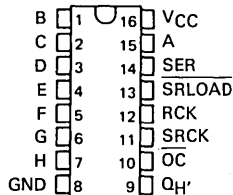

SN54LS589 . . . FK PACKAGE
SN74LS589 . . . FN PACKAGE
(TOP VIEW)

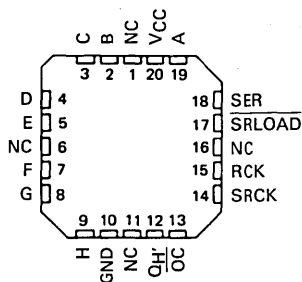

NC - No internal connection

schematics of inputs and outputs

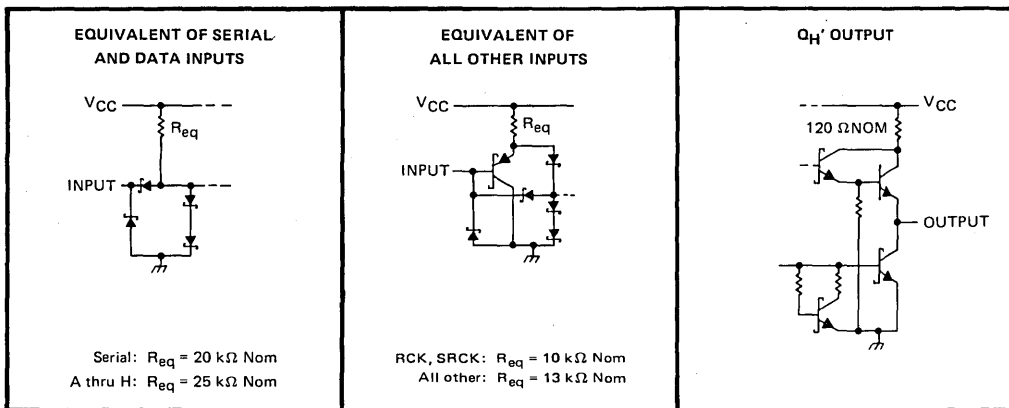

PRODUCTION DATA

This document contains information current as of publication date. Products conform to specifications per the terms of Texas Instruments standard warranty. Production processing does not necessarily include testing of all parameters.



POST OFFICE BOX 225012 • DALLAS, TEXAS 75265



TYPES SN54LS589, SN74LS589
8-BIT SHIFT REGISTERS WITH INPUT LATCHES AND 3-STATE OUTPUT

logic diagram

'LS589

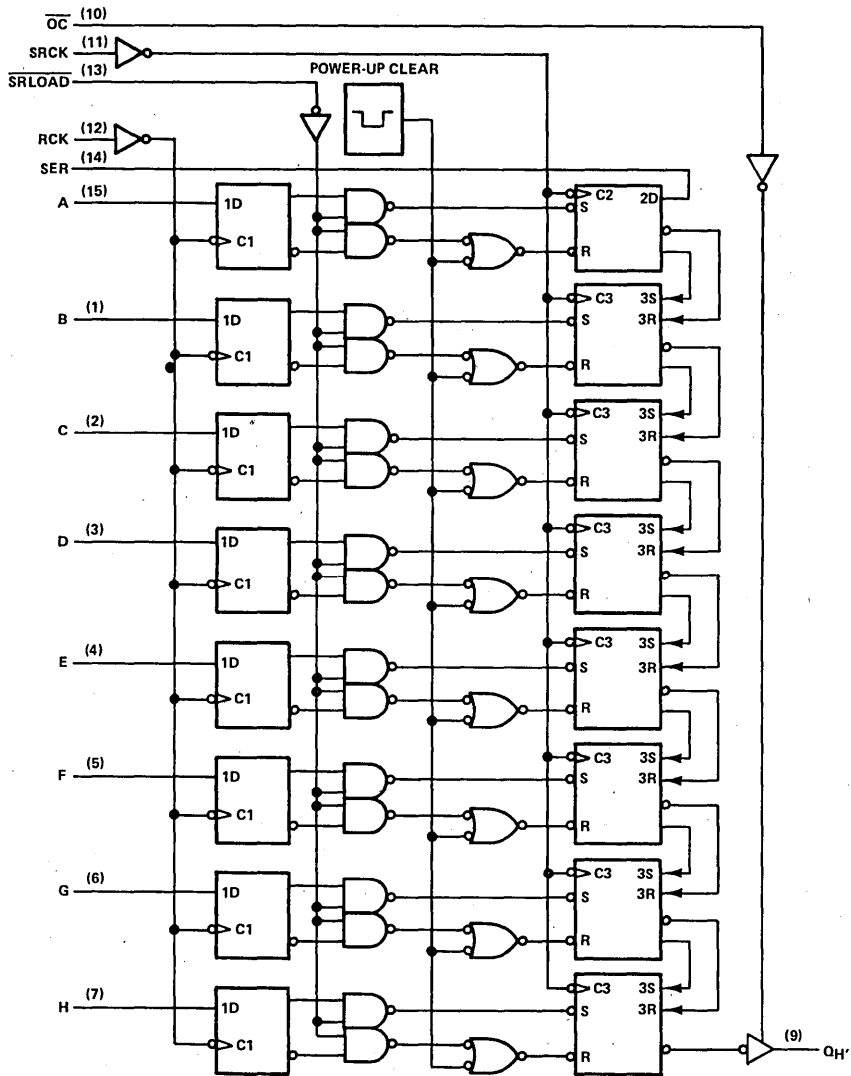

Pin numbers shown on logic notation are for J or N packages.

3 TTL DEVICES

TYPES SN54LS589, SN74LS589

8-BIT SHIFT REGISTERS WITH INPUT LATCHES AND 3-STATE OUTPUT

logic symbol†

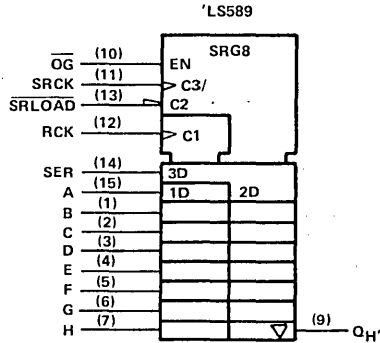

Pin numbers shown on logic notation are for J or N packages.

absolute maximum ratings over operating free-air temperature range (unless otherwise noted)

Supply voltage, V_{CC} (see Note 1)	7 V
Input voltage	7 V
Off-state output voltage	5.5 V
Operating free-air temperature range: SN54LS589	-55°C to 125°C
SN74LS589	0°C to 70°C
Storage temperature range	-65°C to 150°C

NOTE 1: Voltage values are with respect to the network ground terminal.

recommended operating conditions

		SN54LS'			SN74LS'			UNIT		
		MIN	NOM	MAX	MIN	NOM	MAX			
V_{CC}	Supply voltage	4.5	5	5.5	4.75	5	5.25	V		
V_{IH}	High-level input voltage	2			2			V		
V_{IL}	Low-level input voltage	0.7			0.8			V		
I_{OH}	High-level output current	-1			-1			mA		
I_{OL}	Low-level output current	8			16			mA		
f_{SRCK}	Shift clock frequency	0			20			MHz		
t_w	Pulse duration	SRCK	High	15			15	ns		
			Low	35			35			
		RCK	20			20				
		SRLOAD	40			40				
t_{su}	Setup time	Data before RCK ↑	20			20			ns	
		SER before SRCK ↑	20			20				
		SRLOAD inactive before SRCK ↑	30			30				
		RCK ↑ before SRLOAD ↑ (see Note 2)	40			40				
t_h	Hold time	Data after RCK ↑	0			0			ns	
		SER after SRCK ↑	0			0				
T_A	Operating free-air temperature	-55			125			0	70	°C

NOTE 2: The RCK ↑ to SRLOAD setup time ensures the data saved by RCK ↑ will also be loaded into the counter.

3

TTL DEVICES

TYPES SN54LS589, SN74LS589

8-BIT SHIFT REGISTERS WITH INPUT LATCHES AND 3-STATE OUTPUT

electrical characteristics over recommended operating free-air temperature range (unless otherwise noted)

PARAMETER	TEST CONDITIONS†		SN54LS*		SN74LS*		UNIT
			MIN	TYP ‡	MAX	MIN	
V _{IK}	V _{CC} = MIN, I _I = -18 mA		-1.5		-1.5		V
V _{OH}	V _{CC} = MIN, I _{OH} = -1 mA		2.4	3.2	2.4	3.2	V
V _{OL}	V _{CC} = MIN	I _{OL} = 8 mA	0.25	0.4	0.25	0.4	V
		I _{OL} = 16 mA			0.35	0.5	
I _{OZH}	V _{CC} = MAX, V _O = 2.7 V		20		20		μA
I _{OZL}	V _{CC} = MAX, V _O = 0.4 V		-0.2		-0.2		mA
I _{IL}	V _{CC} = MAX, V _I = 7 V		-0.1		-0.1		mA
I _{IH}	V _{CC} = MAX, V _I = 2.7 V		20		20		μA
I _{IL}	SER, A → H	V _{CC} = MAX, V _I = 0.4 V	-0.4		-0.4		mA
	Others		-0.2		-0.2		
I _{OS} §	V _{CC} = MAX, V _O = 0 V		-20	-100	-20	-100	mA
I _{CC}	I _{CCH}	V _{CC} = MAX,	30	45	30	45	mA
	I _{CCL}	All possible inputs grounded,	30	45	30	45	
	I _{CCZ}	Output open	35	53	35	53	

† For conditions shown as MIN or MAX use the appropriate values specified under recommended operating conditions.

‡ All typical values are at V_{CC} = 5 V, T_A = 25°C

switching characteristics, V_{CC} = 5 V, T_A = 25°C (see note 2)

PARAMETER	FROM (INPUT)	TO (OUTPUT)	TEST CONDITIONS	'LS589			UNIT
				MIN	TYP	MAX	
f _{max}	SRCK			20	35		MHz
t _{PLH}	SRCK ↑	Q _H '	R _L = 1 kΩ, C _L = 30 pf	15	23		ns
t _{PHL}				20	30		
t _{PLH}	SRLOAD ↓	Q _H '		38	57		ns
t _{PHL}				29	44		
t _{PLH}	RCK ↑	Q _H '	R _L = 1 kΩ, C _L = 30 pf, SRLOAD = L	41	60		ns
t _{PHL}				32	48		
t _{PZH}	OC	Q _H '	R _L = 667 Ω, C _L = 5 pf	10	15		ns
t _{PZL}				18	27		
t _{PHZ}				20	30		
t _{PLZ}				20	30		

NOTE 2: See General Information Section for load circuits and voltage waveforms.

3

TTL DEVICES

TYPES SN54LS589, SN74LS589
8-BIT SHIFT REGISTERS WITH INPUT LATCHES AND 3-STATE OUTPUT

timing diagram

'LS589

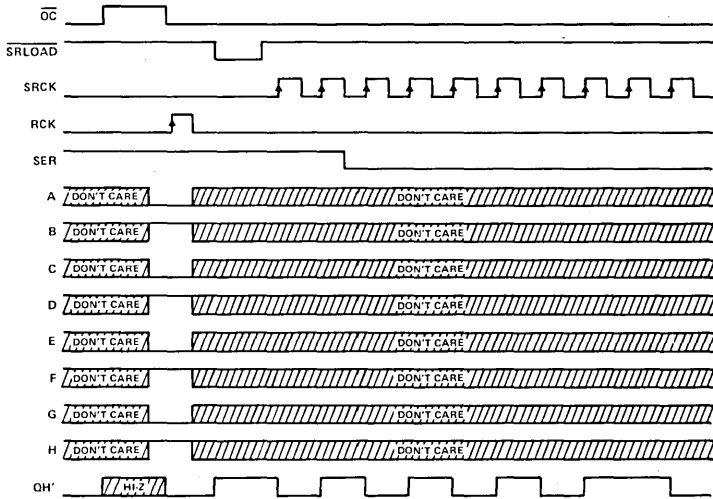

TYPES SN54LS590, SN54LS591, SN74LS590, SN74LS591 8-BIT BINARY COUNTERS WITH OUTPUT REGISTERS

D2632, JANUARY 1981 — REVISED JUNE 1983

- 8-Bit Counter with Register
- Parallel Register Outputs
- Choice of 3-State ('LS590) or Open-Collector ('LS591) Register Outputs
- Guaranteed Counter Frequency: DC to 20 MHz

description

These devices each contain an 8-bit binary counter that feeds an 8-bit storage register. The storage register has parallel outputs. Separate clocks are provided for both the binary counter and storage register. The binary counter features a direct clear input \overline{CCLR} and a count enable input $CCKEN$. For cascading, a ripple carry output \overline{RCO} is provided. Expansion is easily accomplished for two stages by connecting \overline{RCO} of the first stage to $CCKEN$ of the second stage. Cascading for larger count chains can be accomplished by connecting \overline{RCO} of each stage to CCK of the following stage.

Both the counter and register clocks are positive-edge triggered. If the user wishes to connect both clocks together, the counter state will always be one count ahead of the register. Internal circuitry prevents clocking from the clock enable.

SN54LS590, SN54LS591 ... J OR W PACKAGE
SN74LS590, SN74LS591 ... J OR N PACKAGE

(TOP VIEW)

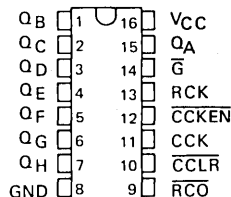

SN54LS590, SN54LS591 ... FK PACKAGE
SN74LS590, SN74LS591 ... FN PACKAGE

(TOP VIEW)

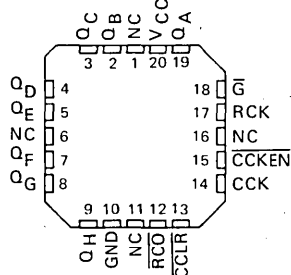

NC - No internal connection

schematics of inputs and outputs

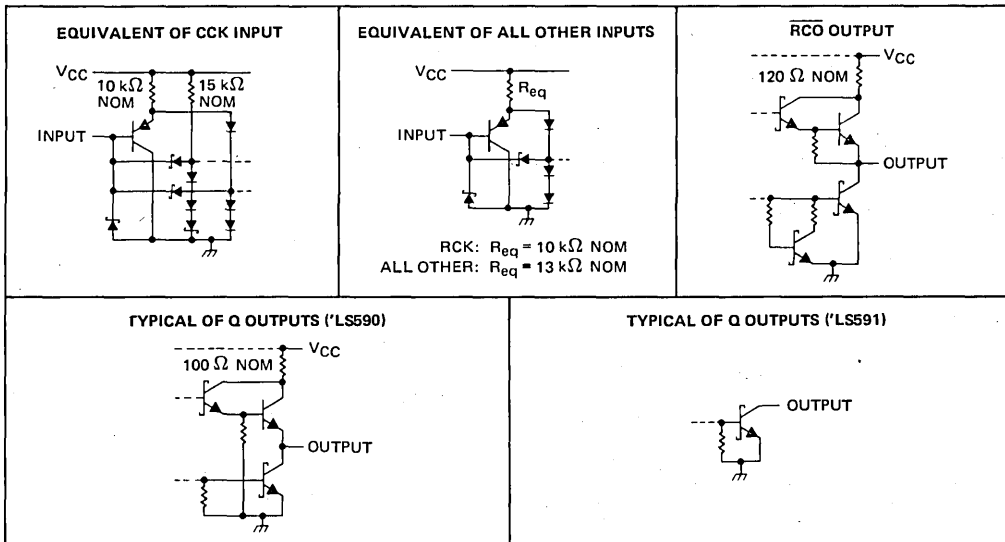

PRODUCTION DATA
This document contains information current as of publication date. Products conform to specifications per the terms of Texas Instruments standard warranty. Production processing does not necessarily include testing of all parameters.

TEXAS INSTRUMENTS

POST OFFICE BOX 225012 • DALLAS, TEXAS 75265

3-1137

TYPES SN54LS590, SN54LS591, SN74LS590, SN74LS591
8-BIT BINARY COUNTERS WITH OUTPUT REGISTERS

logic diagram (positive logic)

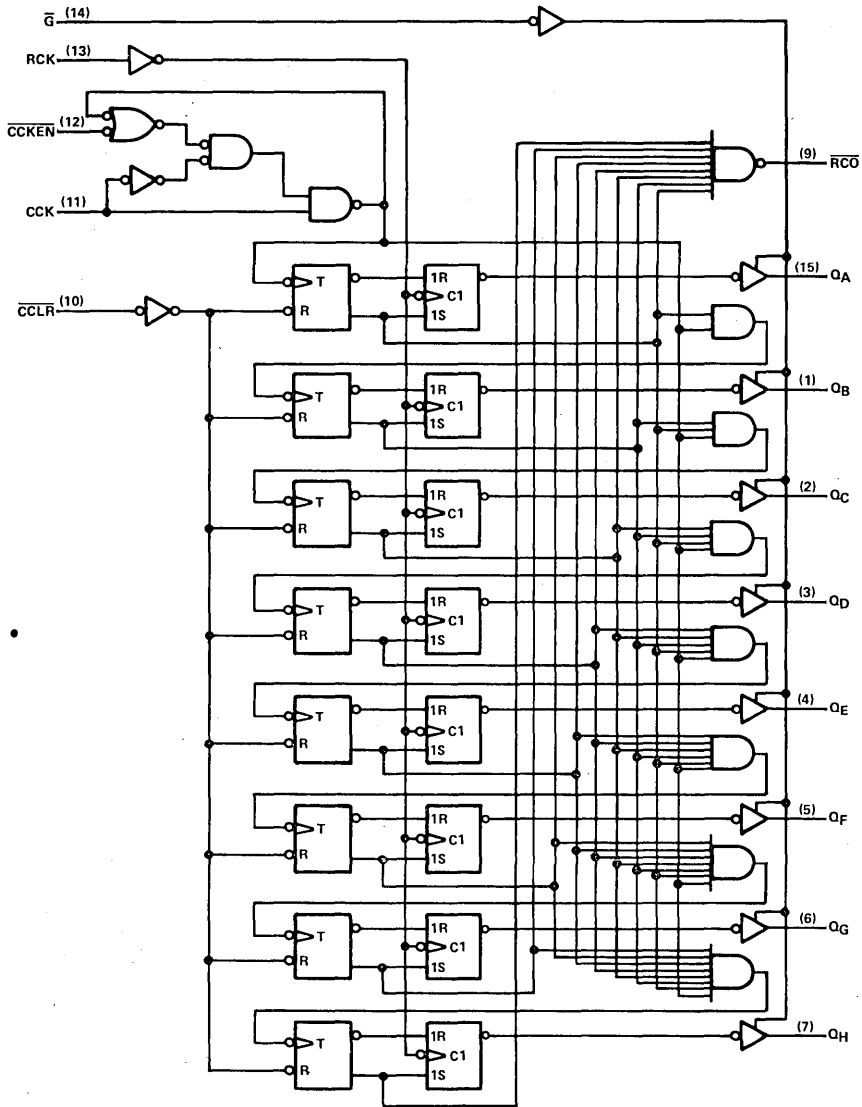

Pin numbers shown on logic notation are for J or N packages.

TYPES SN54LS590, SN54LS591, SN74LS590, SN74LS591 8-BIT BINARY COUNTERS WITH OUTPUT REGISTERS

logic symbols

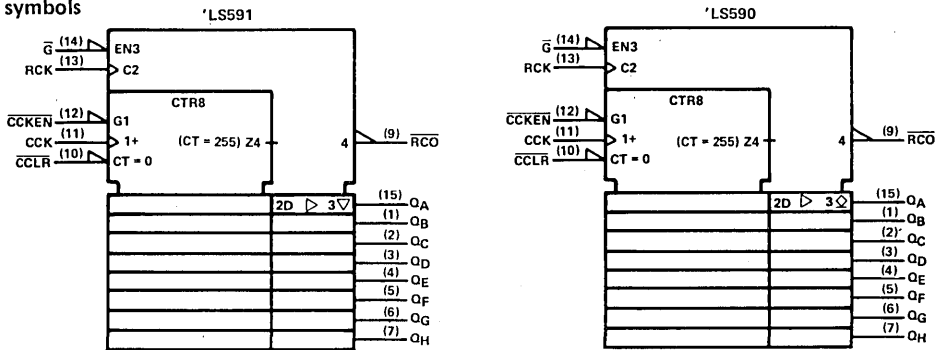

Pin numbers shown on logic notation are for J or N packages.

absolute maximum ratings over operating free-air temperature range (unless otherwise noted)

Supply voltage, V_{CC} (see Note 1)	7 V
Input voltage	7 V
Off-state output voltage	5.5 V
Operating free-air temperature range: SN54LS590, SN54LS591	-55°C to 125°C
SN74LS590, SN74LS591	0°C to 70°C
Storage temperature range	-65°C to 150°C

NOTE 1: Voltage values are with respect to the network ground terminal.

recommended operating conditions

		SN54LS'			SN74LS'			UNIT	
		MIN	NOM	MAX	MIN	NOM	MAX		
V_{CC}	Supply voltage	4.5	5	5.5	4.75	5	5.25	V	
V_{IH}	High-level input voltage	2			2			V	
V_{IL}	Low-level input voltage	0.7			0.8			V	
V_{OH}	High-level output voltage	Q, 'LS591 only		5.5		5.5		V	
I_{OH}	High-level output current	RCO		-1		-1		mA	
		Q, 'LS590 only		-1		-2.6			
I_{OL}	Low-level output current	RCO		8		16		mA	
		Q		12		24			
f_{CCK}	Counter clock frequency	0		20		20		MHz	
f_{RCK}	Register clock frequency	0		25		25		MHz	
$t_w(CCK)$	Duration of counter clock pulse	25		25				ns	
$t_w(CCLR)$	Duration of counter clear pulse	20		20				ns	
$t_w(RCK)$	Duration of register clock pulse	20		20				ns	
t_{su}	Setup time	CCKEN low before CCK↑		20		20		ns	
		CCLR inactive before CCK↑		20		20			
		CCK before RCK↑ (see Note 2)		40		40			
t_h	Hold time	CCKEN low after CCK↑		0		0		ns	
T_A	Operating free-air temperature	-55		125		0		70	°C

NOTE 2: This setup time ensures the register will see stable data from the counter outputs. The clocks may be tied together in which case the register state will be one clock pulse behind the counter.

3

TTL DEVICES

TYPES SN54LS590, SN54LS591, SN74LS590, SN74LS591 8-BIT BINARY COUNTERS WITH OUTPUT REGISTERS

electrical characteristics over recommended operating free-air temperature range (unless otherwise noted)

PARAMETER	TEST CONDITION†		SN54LS*			SN74LS*			UNIT	
			MIN	TYP‡	MAX	MIN	TYP‡	MAX		
V _{IK}		V _{CC} = MIN, I _I = -18 mA			-1.5			-1.5	V	
V _{OH}	'LS590 Q	V _{CC} = MIN, V _{IH} = 2 V, V _{IL} = MAX	I _{OH} = -1 mA		2.4	3.2			V	
	RCO		I _{OH} = -2.6 mA				2.4	3.1		
			I _{OH} = -1 mA		2.4	3.2	2.4	3.2		
I _{OH}	'LS591 Q	V _{CC} = MIN, V _{IH} = 2 V, V _{OH} = 5.5 V, V _{IL} = MAX					0.1	0.1	mA	
V _{OL}	Q	V _{CC} = MIN, V _{IH} = 2 V, V _{IL} = MAX	I _{OL} = 12 mA		0.25	0.4	0.25	0.4	V	
	RCO		I _{OL} = 24 mA				0.35	0.5		
			I _{OL} = 8 mA		0.25	0.4	0.25	0.4		
			I _{OL} = 16 mA				0.35	0.5		
I _{OZH}	'LS590 Q	V _{CC} = MAX, V _O = 2.7 V, V _{IH} = 2 V, V _{IL} = MAX,					20	20	μA	
I _{OZL}	'LS590 Q	V _{CC} = MAX, V _O = 0.4 V, V _{IH} = 2 V, V _{IL} = MAX,					-20	-20	μA	
I _I		V _{CC} = MAX, V _I = 7 V					0.1	0.1	mA	
I _{IH}		V _{CC} = MAX, V _I = 2.7 V					20	20	μA	
I _{IL}	CCK	V _{CC} = MAX, V _I = 0.4 V					-0.8	-0.8	mA	
	All others						-0.2	-0.2		
I _{OS} §	'LS590 Q	V _{CC} = MAX, V _O = 0 V			-30	-130	-30	-130	mA	
	RCO				-20	-100	-20	-100		
I _{CC}	'LS590	V _{CC} = MAX, All possible inputs grounded, All outputs open	I _{CCH}			33	55	33	55	mA
			I _{CCL}			44	65	44	65	
			I _{CCZ}			46	65	46	65	
	'LS591		I _{CCH}			35	55	35	55	
			I _{CCL}			42	65	42	65	

† For conditions shown as MIN or MAX, use the appropriate value specified under recommended operating conditions.

‡ All typical values are at V_{CC} = 5 V, T_A = 25° C

§ Not more than one output should be shorted at a time and the duration of the short-circuit should not exceed one second.

switching characteristics, V_{CC} = 5 V, T_A = 25° C (see note 3)

PARAMETER	FROM (INPUT)	TO (OUTPUT)	TEST CONDITIONS		'LS590			'LS591			UNIT
					MIN	TYP	MAX	MIN	TYP	MAX	
f _{max}	CCK	RCO	R _L = 1 kΩ, C _L = 30 pF		20	35		20	35		MHz
t _{PLH}	CCK↑	RCO			14	22		16	24		ns
t _{PHL}	CCK↑	RCO			20	30		25	38		ns
t _{PLH}	CCLR↓	RCO			30	45		32	48		ns
t _{PLH}	RCK↑	Q	R _L = 667 Ω, C _L = 45 pF		12	18		25	38		ns
t _{PHL}	RCK↑	Q			22	33		28	42		ns
t _{PZH}	Q̄↑	Q			25	38					ns
t _{PZL}	Q̄↑	Q			30	45					ns
t _{PHZ}	Q̄↑	Q	R _L = 667 Ω, C _L = 5 pF		20	30					ns
t _{PLZ}	Q̄↑	Q			25	38					ns
t _{PLH}	Q̄↑	Q						34	50		ns
t _{PHL}	Q̄↑	Q						32	48		ns

NOTE 3: See General Information Section for load circuits and voltage waveforms.

3

TTL DEVICES

TYPES SN54LS592, SN54LS593, SN74LS592, SN74LS593 8-BIT BINARY COUNTERS WITH INPUT REGISTERS

02633, JANUARY 1981 — REVISED DECEMBER 1983

- Parallel Register Inputs ('LS592)
- Parallel 3-State I/O: Register Inputs/Counter Outputs ('LS593)
- Counter has Direct Overriding Load and Clear
- Guaranteed Counter Frequency: DC to 20 MHz

description

The 'LS592 comes in a 16-pin package and consists of a parallel input, 8-bit storage register feeding an 8-bit binary counter. Both the register and the counter have individual positive-edge-triggered clocks. In addition, the counter has direct load and clear functions. A low-going RCO pulse will be obtained when the counter reaches the hex word FF. Expansion is easily accomplished for two stages by connecting RCO of the first stage to CCKEN of the second stage. Cascading for larger count chains can be accomplished by connecting RCO of each stage to CCK of the following stage.

The 'LS593 comes in a 20-pin package and has all the features of the 'LS592 plus 3-state I/O, which provides parallel counter outputs. The tables below show the operation of the enable (CCKEN, $\overline{\text{CCKEN}}$) inputs. A register clock enable (RCKEN) is also provided.

OUTPUT ENABLE CONTROL ('593 ONLY)

G	$\overline{\text{G}}$	A/Q _A thru H/Q _H
L	L	input mode
L	H	input mode
H	L	output mode
H	H	input mode

COUNTER CLOCK ENABLE CONTROL

CCKEN	$\overline{\text{CCKEN}}$	EFFECT ON CCK
L	L	Enable
L	H	Disable
H	L	Enable
H	H	Enable

SN54LS592 ... J OR W PACKAGE
SN74LS592 ... J OR N PACKAGE

(TOP VIEW)

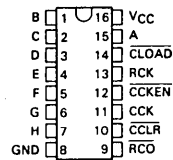

SN54LS592 ... FK PACKAGE
SN74LS592 ... FN PACKAGE

(TOP VIEW)

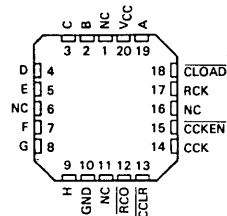

NC — No internal connection

SN54LS593 ... J PACKAGE
SN74LS593 ... DW, J OR N PACKAGE

(TOP VIEW)

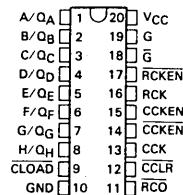

SN54LS593 ... FK PACKAGE
SN74LS593 ... FN PACKAGE

(TOP VIEW)

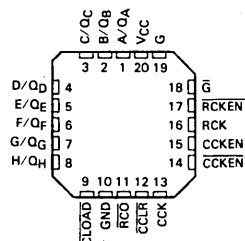

PRODUCTION DATA
This document contains information current as of publication date. Products conform to specifications per the terms of Texas Instruments standard warranty. Production processing does not necessarily include testing of all parameters.

**TEXAS
INSTRUMENTS**

POST OFFICE BOX 225012 • DALLAS, TEXAS 75265

3
TTL DEVICES

TYPES SN54LS592, SN54LS593, SN74LS592, SN74LS593 8-BIT BINARY COUNTERS WITH INPUT REGISTERS

schematics of inputs and outputs

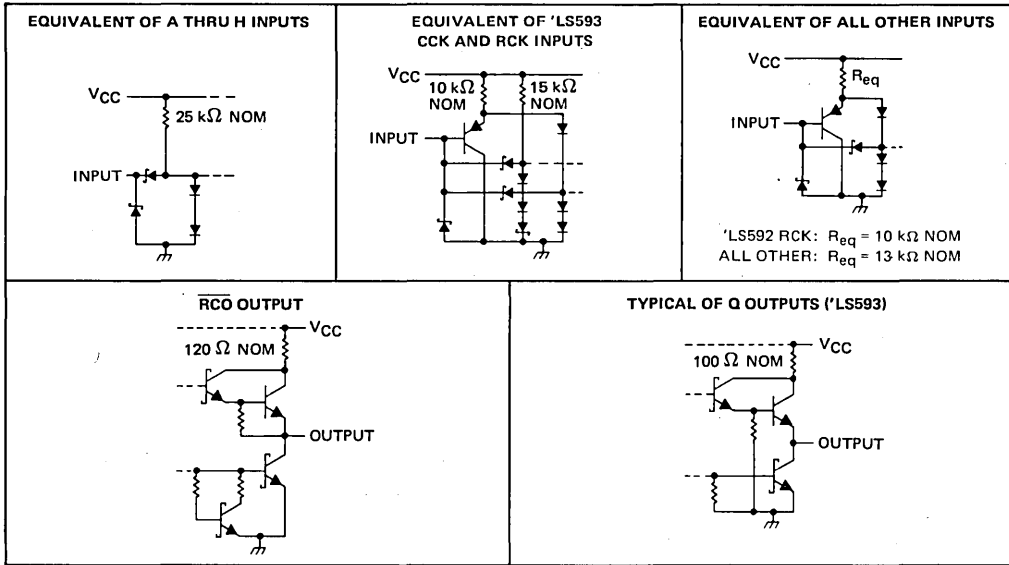

3

logic symbols

TTL DEVICES

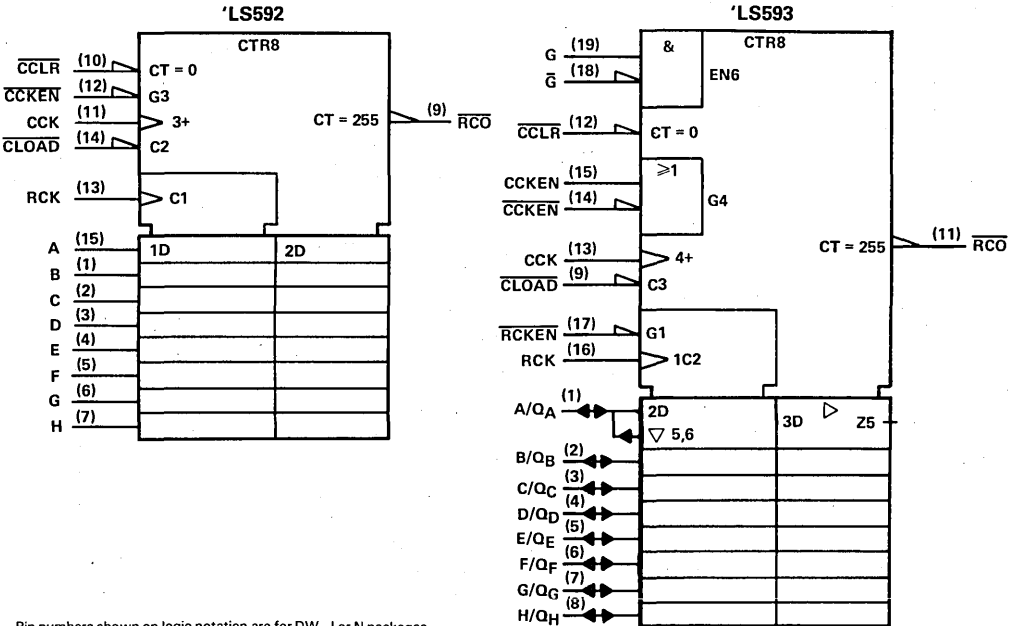

Pin numbers shown on logic notation are for DW, J or N packages.

TYPES SN54LS592, SN74LS592
8-BIT BINARY COUNTERS WITH INPUT REGISTERS

logic diagram (positive logic)

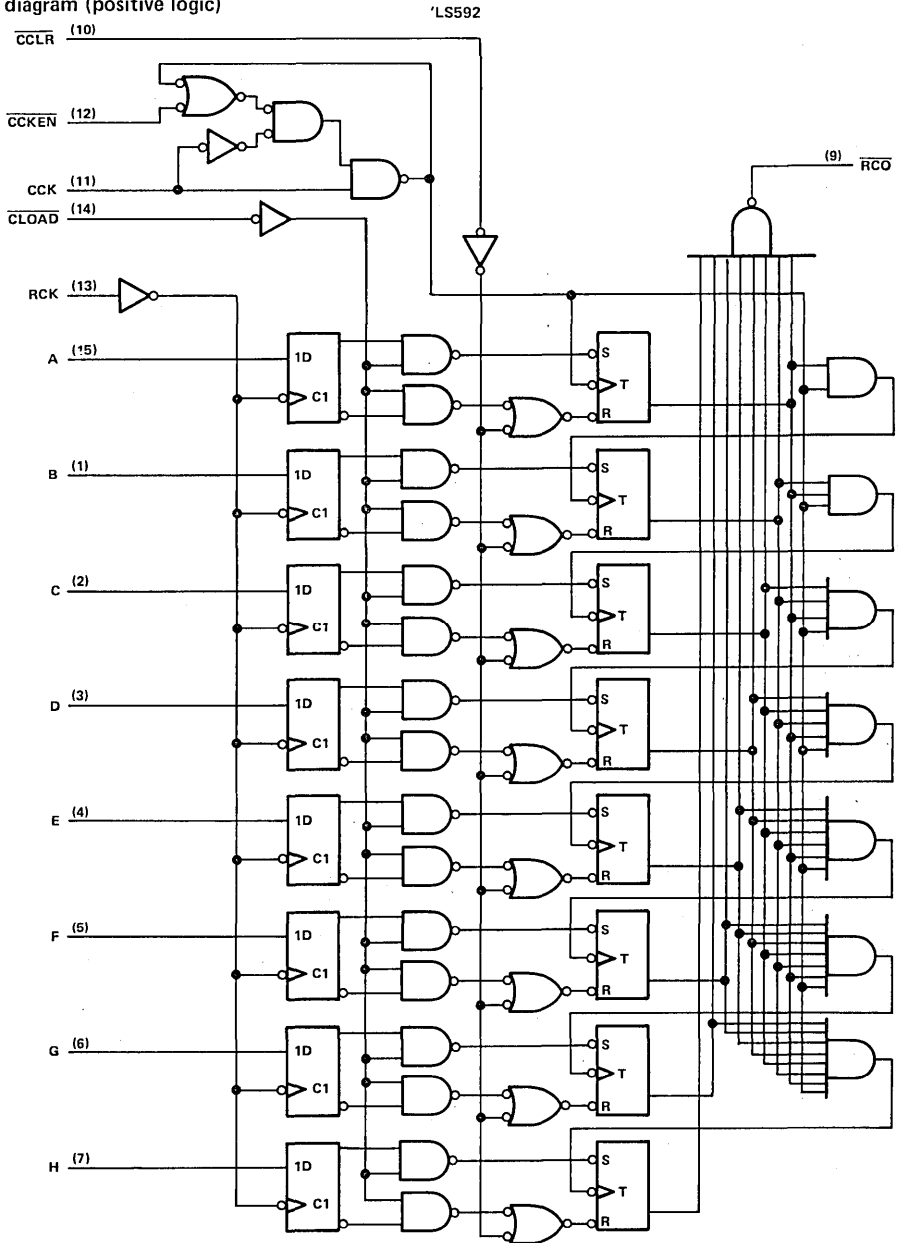

Pin numbers shown on logic notation are for J or N packages.

3
TTL DEVICES

TYPES SN54LS593, SN74LS593 8-BIT BINARY COUNTERS WITH INPUT REGISTERS

logic diagram (positive logic)

'LS593

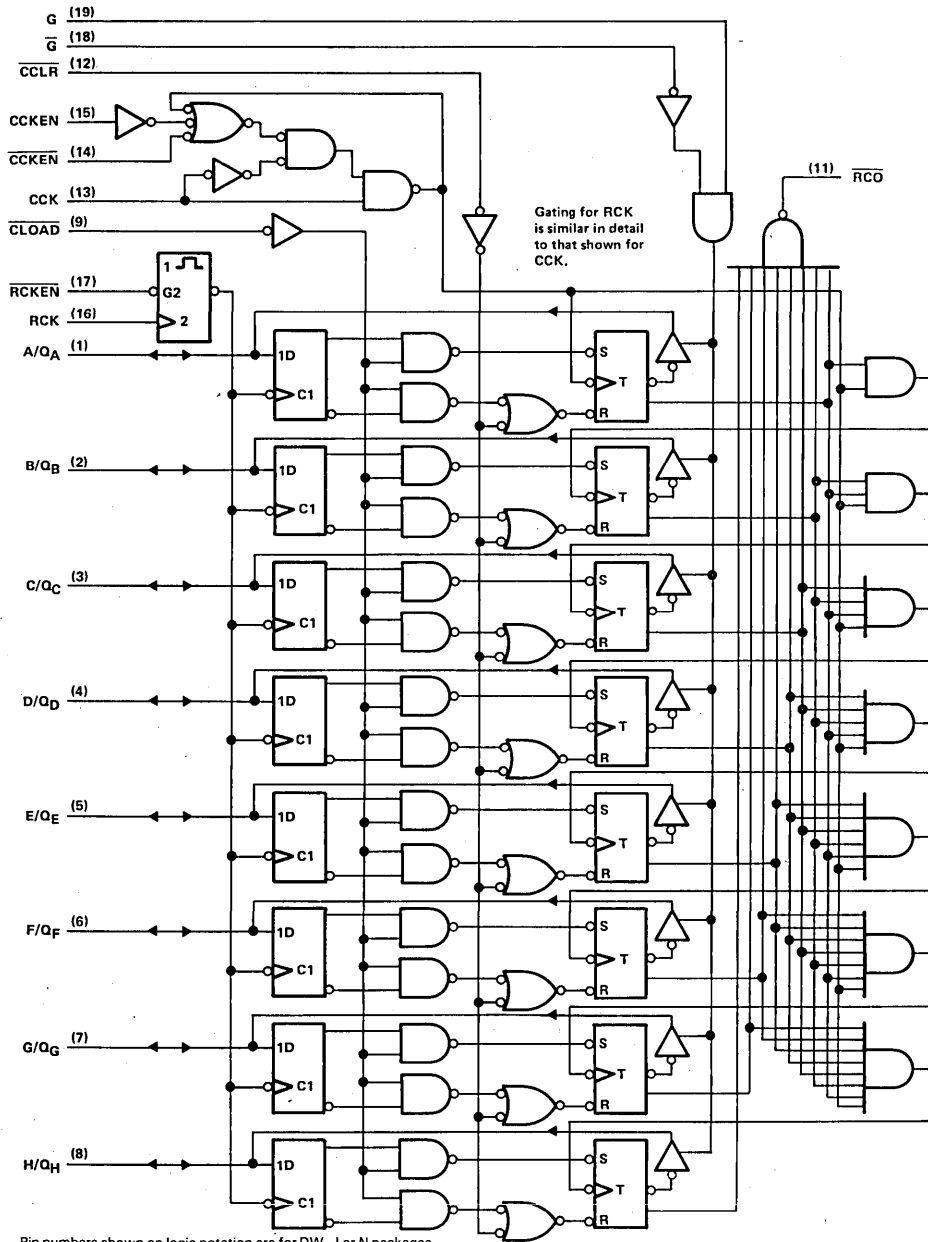

Pin numbers shown on logic notation are for DW, J or N packages.

3

TTL DEVICES

TYPES SN54LS592, SN54LS593, SN74LS592, SN74LS593
8-BIT BINARY COUNTERS WITH INPUT REGISTERS

typical operating sequences

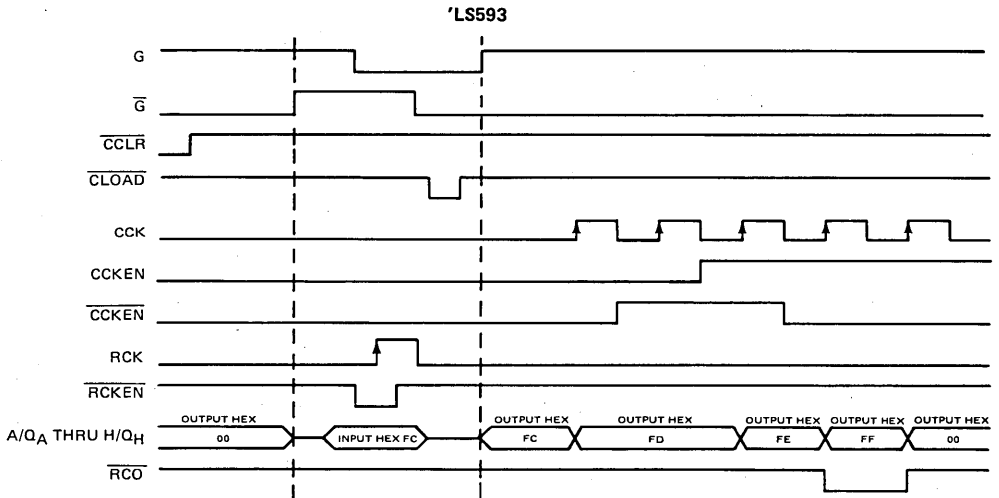
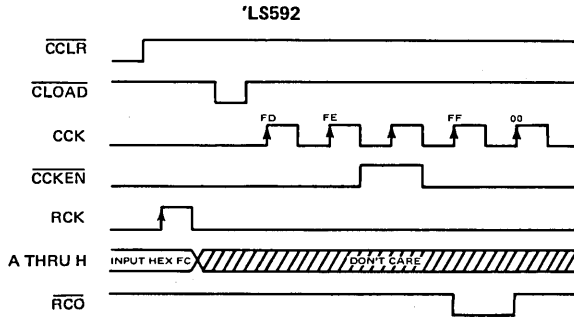

3
TTL DEVICES

TYPES SN54LS592, SN54LS593, SN74LS592, SN74LS593 8-BIT BINARY COUNTERS WITH INPUT REGISTERS

absolute maximum ratings over operating free-air temperature range (unless otherwise noted)

Supply voltage, V_{CC} (see Note 1)	7 V
Input voltage (excluding I/O ports)	7 V
Off-state output voltage (including I/O ports)	5.5 V
Operating free-air temperature range: SN54LS592, SN54LS593	- 55°C to 125°C
SN74LS592, SN74LS593	0°C to 70°C
Storage temperature range	- 65°C to 150°C

NOTE 1: Voltage values are with respect to the network ground terminal.

recommended operating conditions

		SN54LS'			SN74LS'			UNIT
		MIN	NOM	MAX	MIN	NOM	MAX	
V_{CC}	Supply voltage	4.5	5	5.5	4.75	5	5.25	V
V_{IH}	High-level input voltage	2			2			V
V_{IL}	Low-level input voltage	0.7			0.8			V
I_{OH}	High-level output current	\overline{RCO}		-1	\overline{RCO}		-1	mA
		Q 'LS593 only		-1	Q 'LS593 only		-2.6	
I_{OL}	Low-level output current	\overline{RCO}		8	\overline{RCO}		16	mA
		Q 'LS593 only		12	Q 'LS593 only		24	
f_{CCK}	Counter clock frequency	0	20	0	20	20	MHz	
t_w (CCK)	Duration of counter clock pulse	25			25			ns
t_w (CCLR)	Duration of counter clear pulse	20			20			ns
t_w (RCK)	Duration of register clock pulse	20			20			ns
t_w (CLOAD)	Duration of counter load pulse	40			40			ns
t_{su}	Register enable setup time	RCKEN low to RCK ↑, 'LS593		20	20		ns	
		CCKEN low, 'LS592		30	30			
t_{su}	Counter enable setup time before CCK ↑	CCKEN low or		30	30		ns	
		CCKEN high, 'LS593						
t_{su}	Setup time	CCLR inactive before CCK ↑		20	20		ns	
		CLOAD inactive before CCK ↑		20	20			
		RCK ↑ before CLOAD ↑ (see Note 2)		30	30			
		Data A thru H before RCK ↑		20	20			
t_h	Hold time	Data A thru H after RCK ↑		0	0		ns	
		All others		0	0			
T_A	Operating free-air temperature	-55	125	0	70	70	°C	

NOTE 2: This time insures the data saved by RCK ↑ will also be loaded into the counter.

TYPES SN54LS592, SN54LS593, SN74LS592, SN74LS593
8-BIT BINARY COUNTERS WITH INPUT REGISTERS

electrical characteristics over recommended operating free-air temperature range (unless otherwise noted)

PARAMETER		TEST CONDITIONS†			SN54LS*		SN74LS*		UNIT
					MIN	TYP‡	MAX	MIN	
V _{IK}		V _{CC} = MIN, I _I = -18 mA			-1.5		-1.5		V
V _{OH}	'LS593 Q	V _{CC} = MIN, V _{IH} = 2 V, V _{IL} = MAX	I _{OH} = -1 mA		2.4	3.2			V
			I _{OH} = -2.6 mA				2.4	3.1	
	R _{CO}		I _{OH} = -1 mA		2.4	3.2	2.4	3.2	
V _{OL}	'LS593 Q	V _{CC} = MIN, V _{IH} = 2 V, V _{IL} = MAX	I _{OL} = 12 mA		0.25		0.4		V
			I _{OL} = 24 mA				0.35		
	R _{CO}		I _{OL} = 8 mA		0.25		0.4		
			I _{OL} = 16 mA				0.35		
I _{OZH}	'LS593 Q	V _{CC} = MAX, V _O = 2.7 V	V _{IH} = 2 V, V _{IL} = MAX,			20		μA	
I _{OZL}	'LS593 Q	V _{CC} = MAX, V _O = 0.4 V	V _{IH} = 2 V, V _{IL} = MAX,	-0.4		-0.4		mA	
I _I	'LS593 Q	V _{CC} = MAX		V _I = 5.5 V		0.1		mA	
	Others			V _I = 7 V		0.1			
I _{IH}		V _{CC} = MAX, V _I = 2.7 V			20		20		μA
I _{IL}	'LS593 CCK, RCK	V _{CC} = MAX, V _I = 0.4 V			-0.8		-0.8		mA
	A Thru H				-0.4		-0.4		
	Others				-0.2		-0.2		
I _{OS} §	'LS593 Q	V _{CC} = MAX, V _O = 0 V		-30		-130		mA	
	R _{CO}			-20		-100			
I _{CC}	'LS592	I _{CCH}	V _{CC} = MAX,		40		60		mA
		I _{CCL}	All possible inputs grounded,		40		60		
	'LS593	I _{CCH}	All outputs open		47		70		
		I _{CCL}			53		80		
		I _{CCZ}			57		85		

† For conditions shown as MIN or MAX, use the appropriate value specified under recommended operating conditions.

‡ All typical values are at V_{CC} = 5 V, T_A = 25°C.

§ Not more than one output should be shorted at a time and the duration of the short-circuit should not exceed one second.

3
TTL DEVICES

TYPES SN54LS592, SN54LS593, SN74LS592, SN74LS593
8-BIT BINARY COUNTERS WITH INPUT REGISTERS

switching characteristics, $V_{CC} = 5\text{ V}$, $T_A = 25^\circ\text{C}$, (see note 3)

PARAMETER	FROM (INPUT)	TO (OUTPUT)	TEST CONDITIONS	'LS592			'LS593			UNIT	
				MIN	TYP	MAX	MIN	TYP	MAX		
f_{max}	CCK ↑	\overline{RCO}	$R_L = 1\text{ k}\Omega$, $C_L = 30\text{ pF}$	20	35		20	35		MHz	
t_{PLH}	CCK ↑	Q	$R_L = 667\ \Omega$, $C_L = 45\text{ pF}$				14	21		ns	
t_{PHL}	CCK ↑	Q		26	39		ns				
t_{PLH}	\overline{CLOAD} ↓	Q		34	51		ns				
t_{PHL}	\overline{CLOAD} ↓	Q		28	42		ns				
t_{PHL}	\overline{CCLR} ↓	Q		25	38		ns				
t_{PZH}	G ↑	Q		31	47		ns				
t_{PZL}	G ↑	Q		27	40		ns				
t_{PZH}	\overline{G} ↓	Q		29	45		ns				
t_{PZL}	\overline{G} ↓	Q		31	47		ns				
t_{PHZ}	G ↓	Q		33	50		ns				
t_{PLZ}	G ↓	Q	$R_L = 667\ \Omega$, $C_L = 5\text{ pF}$				35	52		ns	
t_{PHZ}	\overline{G} ↑	Q		26	39		ns				
t_{PLZ}	\overline{G} ↑	Q		28	42		ns				
t_{PLH}	CCK ↑	\overline{RCO}		$R_L = 1\text{ k}\Omega$, $C_L = 30\text{ pF}$	15	23		14	21		ns
t_{PHL}	CCK ↑	\overline{RCO}	20		30		20	30		ns	
t_{PLH}	\overline{CLOAD} ↓	\overline{RCO}	31		47		31	47		ns	
t_{PHL}	\overline{CLOAD} ↓	\overline{RCO}	27		41		27	41		ns	
t_{PLH}	\overline{CCLR} ↓	\overline{RCO}	30		45		30	45		ns	
t_{PLH}	RCK ↑	\overline{RCO}	$R_L = 1\text{ k}\Omega$, $C_L = 30\text{ pF}$		35	53		42	63		ns
t_{PHL}	RCK ↑	\overline{RCO}			30	45		33	50		ns

NOTE 3: See General Information Section for load circuits and voltage waveforms.

3

TTL DEVICES

TYPES SN54LS594, SN54LS599, SN74LS594, SN74LS599 8-BIT SHIFT REGISTERS WITH OUTPUT LATCHES

D2747, JUNE 1983 — REVISED DECEMBER 1983

- **8-Bit Serial-In, Parallel-Out Shift Registers with Storage**
- **Choice of Output Configurations:**
'LS594 ... Buffered
'LS599 ... Open-Collector
- **Guaranteed Shift Frequency:**
DC to 20 MHz
- **Independent Direct-Overriding Clears on Shift and Storage Registers**
- **Independent Clocks for Both Shift and Storage Registers**

SN54LS594, SN54LS599 ... J OR W PACKAGE
SN74LS594, SN74LS599 ... J OR N PACKAGE
(TOP VIEW)

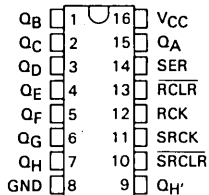

SN54LS594, SN54LS599 ... FK PACKAGE
SN74LS594, SN74LS599 ... FN PACKAGE
(TOP VIEW)

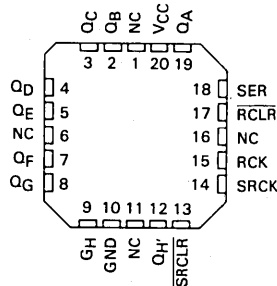

description

These devices each contain an 8-bit D-type storage register. The storage register has buffered ('LS594) or open-collector ('LS599) outputs. Separate clocks and direct-overriding clears are provided on both the shift and storage registers. A shift output (Q_H') is provided for cascading purposes.

Both the shift register and the storage register clocks are positive-edge triggered. If the user wishes to connect both clocks together, the shift register will always be one clock pulse ahead of the storage register.

schematics of inputs and outputs

NC — No internal connection

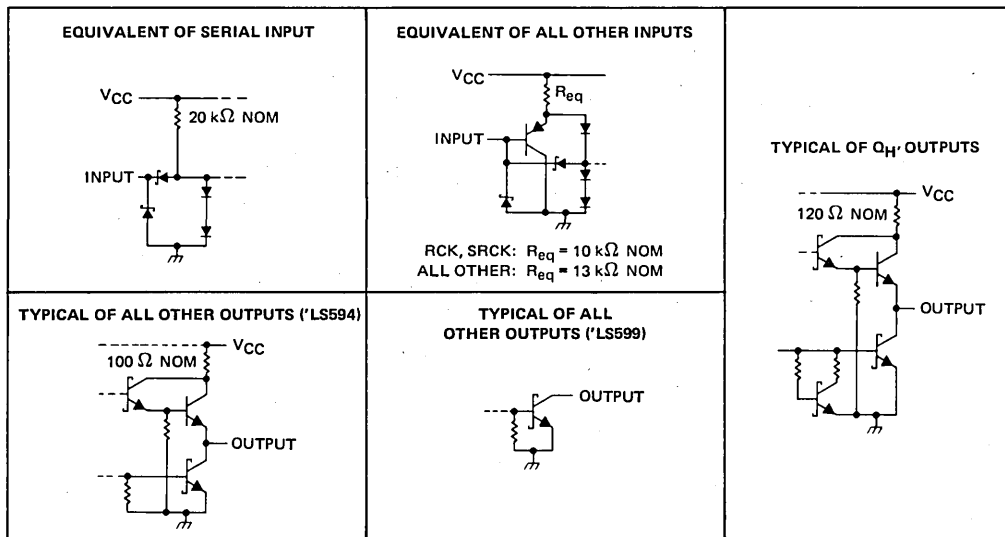

PRODUCTION DATA
This document contains information current as of publication date. Products conform to specifications per the terms of Texas Instruments standard warranty. Production processing does not necessarily include testing of all parameters.

**TEXAS
INSTRUMENTS**

POST OFFICE BOX 225012 • DALLAS, TEXAS 75265

3-1149

TYPES SN54LS594, SN54LS599, SN74LS594, SN74LS599
8-BIT SHIFT REGISTERS WITH OUTPUT LATCHES

logic diagram (positive logic)

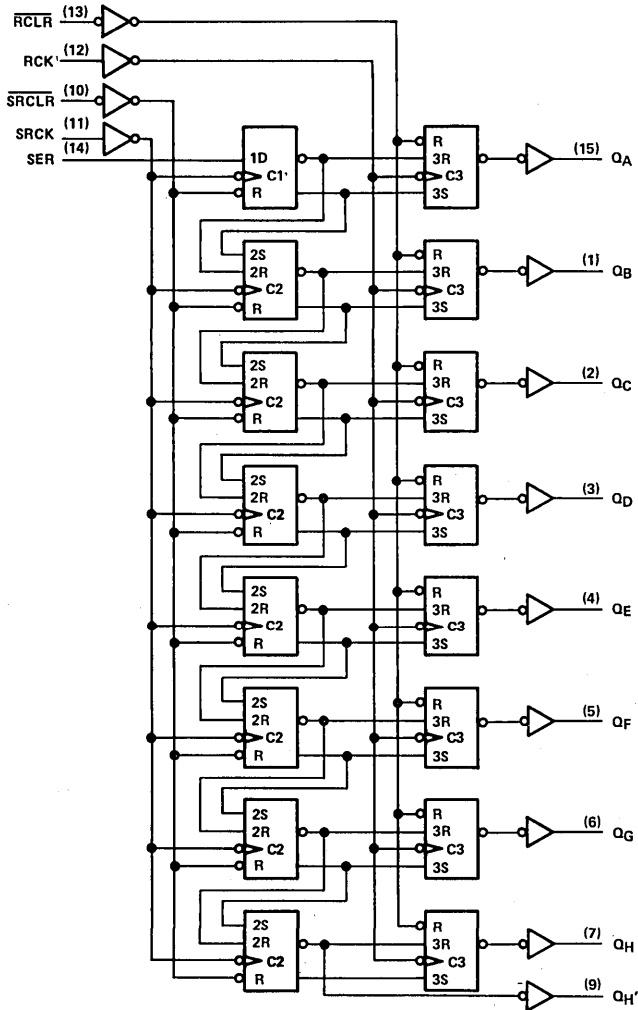

Pin numbers shown on logic notation are for J or N packages.

TYPES SN54LS594, SN54LS599, SN74LS594, SN74LS599 8-BIT, SHIFT REGISTERS WITH OUTPUT LATCHES

logic symbols

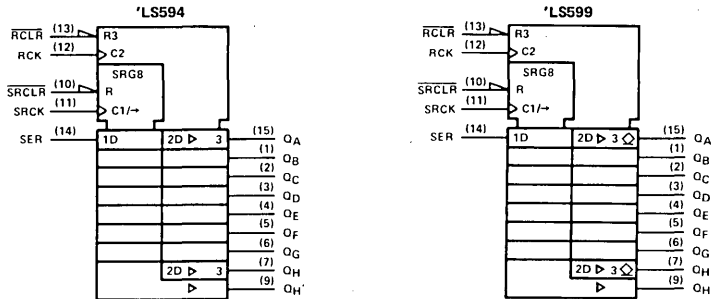

Pin numbers shown on logic notation are for J or N packages.

absolute maximum ratings over operating free-air temperature range (unless otherwise noted)

Supply voltage, V_{CC} (see Note 1)	7 V
Input voltage	7 V
Off-state output voltage	5.5 V
Operating free-air temperature range: SN54LS594, SN54LS599	-55°C to 125°C
SN74LS594, SN74LS599	0°C to 70°C
Storage temperature range	-65°C to 150°C

NOTE 1: Voltage values are with respect to the network ground terminal.

recommended operating conditions

		SN54LS'			SN74LS'			UNIT	
		MIN	NOM	MAX	MIN	NOM	MAX		
V_{CC}	Supply voltage	4.5	5	5.5	4.75	5	5.25	V	
V_{IH}	High-level input voltage	2						V	
V_{IL}	Low-level input voltage	0.7						V	
V_{OH}	High-level output voltage	Q _A thru Q _H , 'LS599 only			0.8			V	
I_{OH}	High-level output current	Q _H '			5.5			5.5	
		Q _A thru Q _H , 'LS594 only			-1			-1	
I_{OL}	Low-level output current	Q _H '			-1			-2.6	
		Q			8			16	
f_{SRCK}	Shift clock frequency	0			20			MHz	
f_{RCK}	Register clock frequency	0			25			MHz	
$t_w(SRCK)$	Duration of shift clock pulse	25			25			ns	
$t_w(RCK)$	Duration of register clock pulse	20			20			ns	
$t_w(SRCLR)$	Duration of shift clear pulse, low level	20			20			ns	
$t_w(RCLR)$	Duration of register clear pulse, low level	35			35			ns	
t_{su}	Setup time	SRCLR inactive before SRCK↑		20		20		ns	
		SER before SRCK↑		20		20			
		SRCK↑ before RCK↑ (see Note 2)		40		40			
		SRCLR low before RCK↑		40		40			
		RCLR high before RCK↑		20		20			
t_h	Hold time	SER after SRCK↑		0		0		ns	
T_A	Operating free-air temperature	-55		125		0		70	°C

NOTE 2: This setup time ensures the register will see stable data from the shift-register outputs. The clocks may be connected together, in which case the storage register state will be one clock pulse behind the shift register.



TTL DEVICES

TYPES SN54LS594, SN54LS599, SN74LS594, SN74LS599

8-BIT, SHIFT REGISTERS WITH OUTPUT LATCHES

electrical characteristics over recommended operating free-air temperature range (unless otherwise noted)

PARAMETER	TEST CONDITIONS †	SN54LS'		SN74LS'		UNIT
		MIN	TYP ‡	MAX	MIN	
V_{IK}	$V_{CC} = \text{MIN}, I_I = -18 \text{ mA}$	-1.5		-1.5		V
V_{OH}	'LS594 Q $V_{CC} = \text{MIN}, V_{IH} = 2 \text{ V}, V_{IL} = \text{MAX}$	$I_{OH} = -1 \text{ mA}$				V
		$I_{OH} = -2.6 \text{ mA}$		2.4 3.1		
		$I_{OH} = -1 \text{ mA}$		2.4 3.2		
I_{OH}	'LS599 Q $V_{CC} = \text{MIN}, V_{OH} = 5.5 \text{ V}, V_{IH} = 2 \text{ V}, V_{IL} = \text{MAX}$	0.1		0.1		mA
V_{OL}	Q $V_{CC} = \text{MIN}, V_{IH} = 2 \text{ V}, V_{IL} = \text{MAX}$	$I_{OL} = 12 \text{ mA}$		0.25 0.4		0.25 0.4
		$I_{OL} = 24 \text{ mA}$				0.35 0.5
		$I_{OL} = 8 \text{ mA}$		0.25 0.4		0.25 0.4
		$I_{OL} = 16 \text{ mA}$				0.35 0.5
I_I	$V_{CC} = \text{MAX}, V_I = 7 \text{ V}$	0.1		0.1		mA
I_{IH}	$V_{CC} = \text{MAX}, V_I = 2.7 \text{ V}$	20		20		μA
I_{IL}	SER			-0.4		-0.4
	All others	$V_{CC} = \text{MAX}, V_I = 0.4 \text{ V}$		-0.2		-0.2
$I_{OS} \S$	'LS594 Q	$V_{CC} = \text{MAX}, V_O = 0$		-30	-130	-30 -130
	Q_H'			-20	-100	-20 -100
I_{CCH}	'LS594	$V_{CC} = \text{MAX}$		34	50	34 50
	'LS599	All possible inputs grounded, All outputs open		30	45	30 45
I_{CCL}	'LS594			42	65	42 65
	'LS599			38	55	38 55

† For conditions shown as MIN or MAX, use the appropriate value specified under recommended operating conditions.

‡ All typical values are at $V_{CC} = 5 \text{ V}, T_A = 25^\circ\text{C}$.

§ Not more than one output should be shorted at a time, and duration of the short-circuit should not exceed one second.

switching characteristics, $V_{CC} = 5 \text{ V}, T_A = 25^\circ\text{C}$, (see note 3)

PARAMETER	FROM (INPUT)	TO (OUTPUT)	TEST CONDITIONS	'LS594			'LS599			UNIT
				MIN	TYP	MAX	MIN	TYP	MAX	
t_{PLH}	SRCK†	Q_H'	$R_L = 1 \text{ k}\Omega, C_L = 30 \text{ pF}$	12	18		12	18	ns	
t_{PHL}				15	23		17	25	ns	
t_{PLH}	RCK†	Q_A thru Q_H	$R_L = 667 \Omega, C_L = 45 \text{ pF}$	12	18		28	42	ns	
t_{PHL}				20	30		24	35	ns	
t_{PHL}	SRCLR‡	Q_H'	$R_L = 1 \text{ k}\Omega, C_L = 30 \text{ pF}$	22	33		24	35	ns	
t_{PHL}				RCLR‡	Q_A thru Q_H	$R_L = 667 \Omega, C_L = 45 \text{ pF}$	38	57		40

NOTE 3: See General Information Section for load circuits and voltage waveforms.

TYPES SN54LS595, SN54LS596, SN74LS595, SN74LS596 8-BIT SHIFT REGISTERS WITH OUTPUT LATCHES

02634, JANUARY 1981 — REVISED DECEMBER 1983

- 8-Bit Serial-In, Parallel-Out Shift Registers with Storage
- Choice of 3-State ('LS595) or Open-Collector ('LS596) Parallel Outputs
- Shift Register Has Direct Clear
- Guaranteed Shift Frequency: DC to 20 MHz

SN54LS595, SN54LS596 ... J OR W PACKAGE
SN74LS595, SN74LS596 ... J OR N PACKAGE

(TOP VIEW)

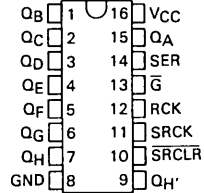

description

These devices each contain an 8-bit serial-in, parallel-out shift register that feeds an 8-bit D-type storage register. The storage register has parallel 3-state ('LS595) or open-collector ('LS596) outputs. Separate clocks are provided for both the shift register and the storage register. The shift register has a direct-overriding clear, serial input, and serial output pins for cascading.

Both the shift register and storage register clocks are positive-edge triggered. If the user wishes to connect both clocks together, the shift register state will always be one clock pulse ahead of the storage register.

SN54LS595, SN54LS596 ... FK PACKAGE
SN74LS595, SN74LS596 ... FN PACKAGE

(TOP VIEW)

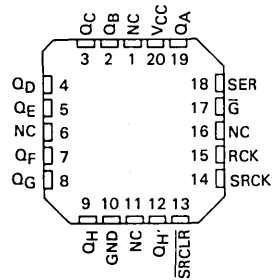

NC - No internal connection

schematics of inputs and outputs

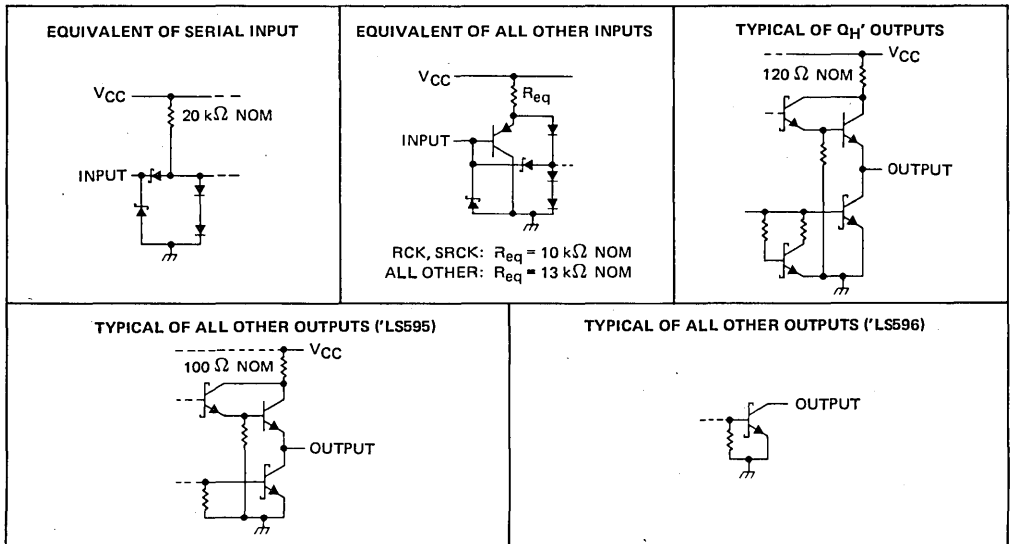

PRODUCTION DATA
This document contains information current as of publication date. Products conform to specifications per the terms of Texas Instruments standard warranty. Production processing does not necessarily include testing of all parameters.

TEXAS INSTRUMENTS
POST OFFICE BOX 225012 • DALLAS, TEXAS 75265

3-1153



TTL DEVICES

TYPES SN54LS595, SN54LS596, SN74LS595, SN74LS596

8-BIT SHIFT REGISTERS WITH OUTPUT LATCHES

logic diagram (positive logic)

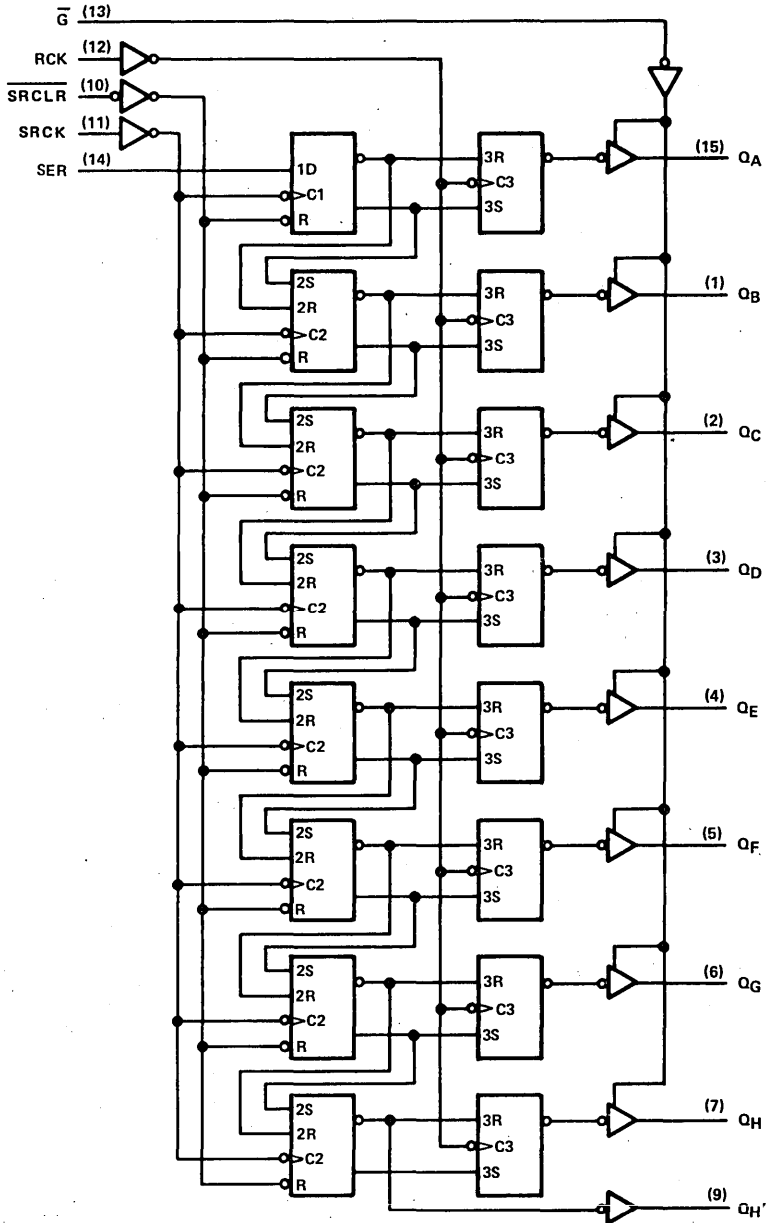

Pin numbers shown on logic notation are for J or N packages.



TTL DEVICES

TYPES SN54LS595, SN54LS596, SN74LS595, SN74LS596

8-BIT SHIFT REGISTERS WITH OUTPUT LATCHES

electrical characteristics over recommended operating free-air temperature range (unless otherwise noted)

PARAMETER	TEST CONDITIONS †		SN54LS'		SN74LS'		UNIT
			MIN	TYP‡	MAX	MIN	
V _{IK}	V _{CC} = MIN, I _I = -18 mA		-1.5		-1.5		V
V _{OH}	'LS595 Q	V _{CC} = MIN, V _{IH} = 2 V, V _{IL} = MAX	I _{OH} = -1 mA				V
	Q _H '		I _{OH} = -2.6 mA		2.4 3.1		
			I _{OH} = -1 mA		2.4 3.2		
I _{OH}	'LS596 Q	V _{CC} = MIN, V _{IH} = 2 V, V _{IL} = MAX, V _{OH} = 5.5 V			0.1		mA
V _{OL}	Q	V _{CC} = MIN, V _{IH} = 2 V, V _{IL} = MAX	I _{OL} = 12 mA		0.25 0.4		V
			I _{OL} = 24 mA		0.35 0.5		
			I _{OL} = 8 mA		0.25 0.4		
			I _{OL} = 16 mA		0.35 0.5		
I _{OZH}	'LS595 Q	V _{CC} = MAX, V _{IH} = 2 V, V _{IL} = MAX, V _{OH} = 2.7 V	20		20		μA
I _{OZL}	'LS595 Q	V _{CC} = MAX, V _{IH} = 2 V, V _{IL} = MAX, V _{OH} = 0.4 V	-20		-20		μA
I _I		V _{CC} = MAX, V _I = 7 V	0.1		0.1		mA
I _{IH}		V _{CC} = MAX, V _I = 2.7 V	20		20		μA
I _{IL}	SER	V _{CC} = MAX, V _I = 0.4 V	-0.4		-0.4		mA
	All others		-0.2		-0.2		
I _{OS} §	'LS595 Q	V _{CC} = MAX, V _O = 0 V	-30	-130	-30	-130	mA
	Q _H '		-20	-100	-20	-100	
I _{CCH}	'LS595	V _{CC} = MAX,	33	50	33	50	mA
	'LS596		30	45	30	45	
I _{CCL}	'LS595	All possible inputs grounded,	42	65	42	65	mA
	'LS596	All outputs open	36	55	36	55	
I _{CCZ}	'LS595		44	65	44	65	mA

† For conditions shown as MIN or MAX, use the appropriate value specified under recommended operating conditions.

‡ All typical values are at V_{CC} = 5 V, T_A = 25°C.

§ Not more than one output should be shorted at a time, and duration of the short-circuit should not exceed one second.

3

TTL DEVICES

TYPES SN54LS595, SN54LS596, SN74LS595, SN74LS596
8-BIT SHIFT REGISTERS WITH OUTPUT LATCHES

switching characteristics, $V_{CC} = 5\text{ V}$, $T_A = 25^\circ\text{C}$ (see note 3)

PARAMETER	FROM (INPUT)	TO (OUTPUT)	TEST CONDITIONS	'LS595			'LS596			UNIT
				MIN	TYP	MAX	MIN	TYP	MAX	
tPLH	SRCK ↑	QH'	$R_L = 1\text{ k}\Omega$, $C_L = 30\text{ pF}$	12		18	14		21	ns
tPHL				17		25	20		30	ns
tPLH	RCK ↑	QA thru QH	$R_L = 667\ \Omega$, $C_L = 45\text{ pF}$	12		18	28		42	ns
tPHL				24		35	24		35	ns
tPZH	$\bar{G} \downarrow$	QA thru QH		20		30				ns
tPZL				25		38				ns
tPHZ	$\bar{G} \uparrow$	QA thru QH	$R_L = 667\ \Omega$, $C_L = 5\text{ pF}$	20		30				ns
tPLZ				25		38				ns
tPLH	$\bar{G} \uparrow$	QA thru QH	$R_L = 667\ \Omega$, $C_L = 45\text{ pF}$				40		60	ns
tPHL	$\bar{G} \downarrow$	QA thru QH					25		38	ns
tPHL	SRCLR ↑	QH'	$R_L = 1\text{ k}\Omega$, $C_L = 30\text{ pF}$	24		35	24		35	ns

NOTE 3: See General Information Section for load circuits and voltage waveforms.

3

TTL DEVICES

TYPES SN54LS597, SN54LS598, SN74LS597, SN74LS598 8-BIT SHIFT REGISTERS WITH INPUT LATCHES

02635, JANUARY 1981—REVISED DECEMBER 1983

- 8-Bit Parallel Storage Register Inputs ('LS597)
- Parallel 3-State I/O, Storage Register Inputs, Shift Register Outputs ('LS598)
- Shift Register has Direct Overriding Load and Clear
- Guaranteed Shift Frequency ... DC to 20 MHz

description

The 'LS597 comes in a 16-pin package and consists of an 8-bit storage latch feeding a parallel-in, serial-out 8-bit shift register. Both the storage register and shift register have positive-edge triggered clocks. The shift register also has direct load (from storage) and clear inputs.

The 'LS598 comes in a 20-pin package and has all the features of the 'LS597 plus 3-state I/O ports that provide parallel shift register outputs and also has multiplexed serial data inputs.

SN54LS597 ... J PACKAGE
SN74LS597 ... J OR N PACKAGE

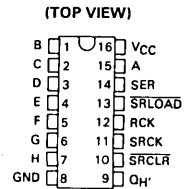

SN54LS597 ... FK PACKAGE
SN74LS597 ... FN PACKAGE

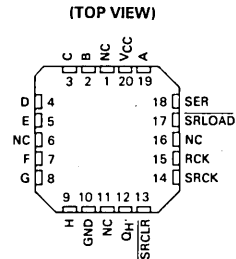

SN54LS598 ... J PACKAGE
SN74LS598 ... DW, J OR N PACKAGE

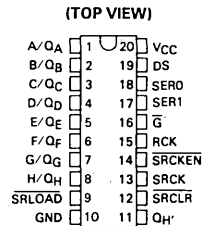

SN54LS598 ... FK PACKAGE
SN74LS598 ... FN PACKAGE

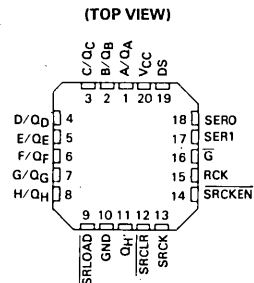

NC - No internal connection

PRODUCTION DATA
This document contains information current as of publication date. Products conform to specifications per the terms of Texas Instruments standard warranty. Production processing does not necessarily include testing of all parameters.

**TEXAS
INSTRUMENTS**

POST OFFICE BOX 225012 • DALLAS, TEXAS 75265

3-1159

TYPES SN54LS597, SN54LS598, SN74LS597, SN74LS598 8-BIT SHIFT REGISTERS WITH INPUT LATCHES

schematics of inputs and outputs

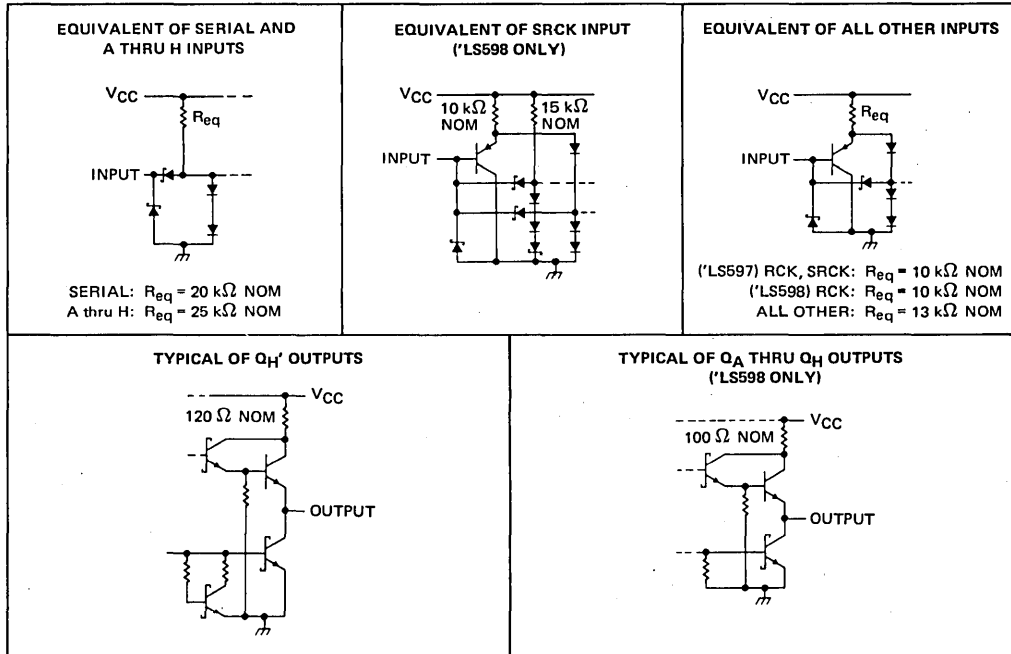

3 TTL DEVICES

logic symbols

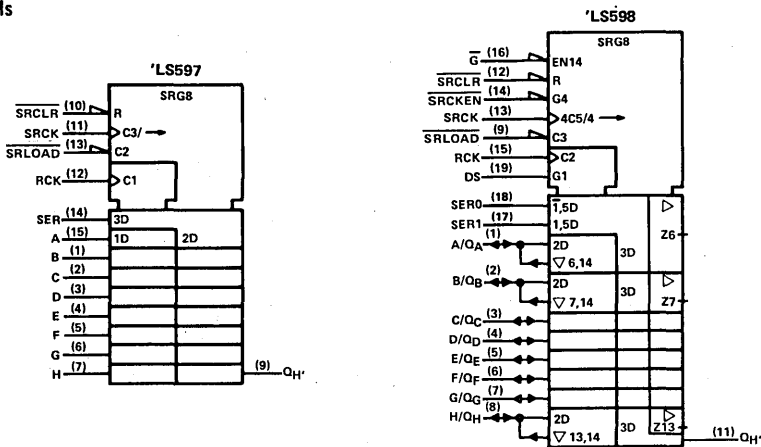

Pin numbers shown on logic notation are for DW, J or N packages.

TYPES SN54LS597, SN74LS597
8-BIT SHIFT REGISTERS WITH INPUT LATCHES

logic diagram (positive logic)

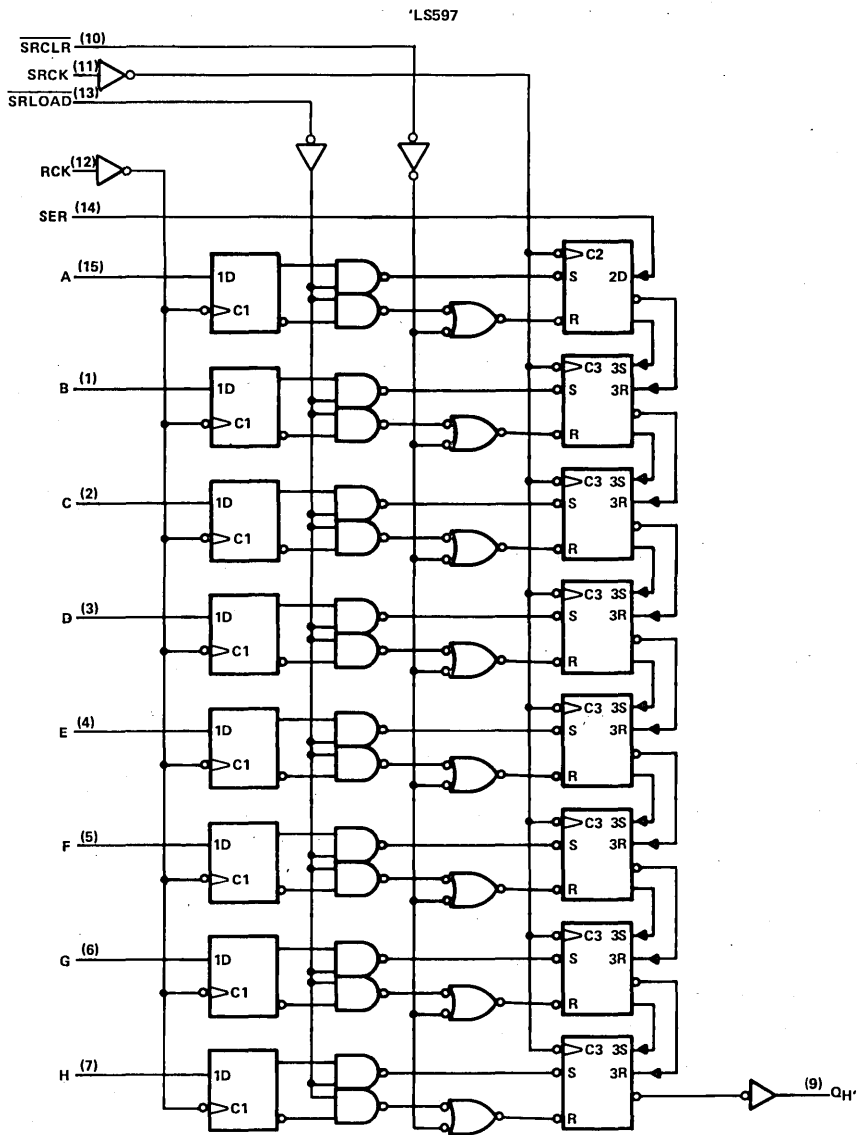

Pin numbers shown on logic notation are for J or N packages.

3
TTL DEVICES

TYPES SN54LS598, SN74LS598
8-BIT SHIFT REGISTERS WITH INPUT LATCHES

logic diagram (positive logic)

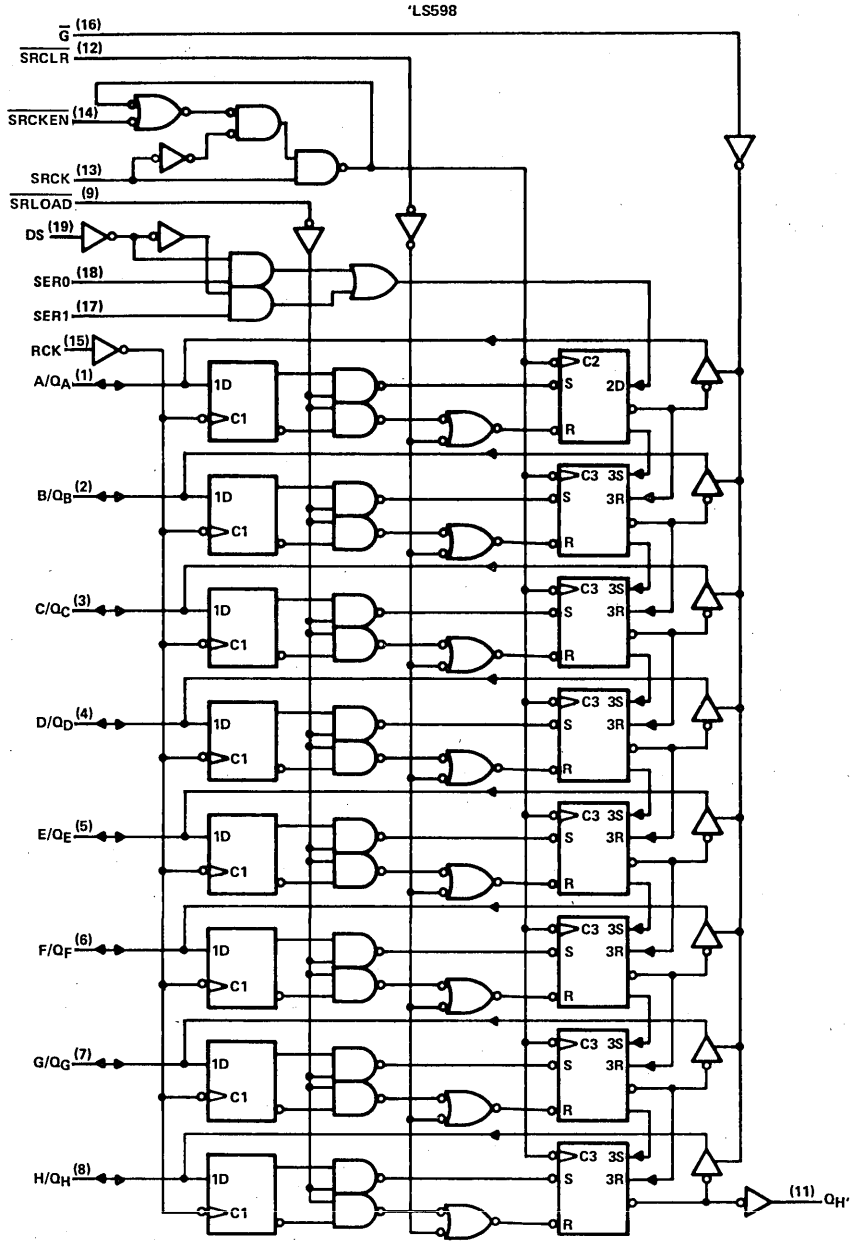

Pin numbers shown on logic notation are for DW, J or N packages.

3
TTL DEVICES

TYPES SN54LS597, SN54LS598, SN74LS597, SN74LS598 8-BIT SHIFT REGISTERS WITH INPUT LATCHES

absolute maximum ratings over operating free-air temperature range (unless otherwise noted)

Supply voltage, V_{CC} (see Note 1)	7 V
Input voltage (excluding I/O ports)	7 V
Off-state output voltage (including I/O ports)	5.5 V
Operating free-air temperature range: SN54LS597, SN54LS598	-55°C to 125°C
SN74LS597, SN74LS598	0°C to 70°C
Storage temperature range	-65°C to 150°C

NOTE 1: Voltage values are with respect to the network ground terminal.

recommended operating conditions

		SN54LS*			SN74LS*			UNIT
		MIN	NOM	MAX	MIN	NOM	MAX	
V_{CC}	Supply voltage	4.5	5	5.5	4.75	5	5.25	V
V_{IH}	High-level input voltage	2			2			V
V_{IL}	Low-level input voltage	0.7			0.8			V
I_{OH}	High-level output current	Q_H'	-1		-1		mA	
		Q_A thru Q_H , 'LS598 only	-1		-2.6			
I_{OL}	Low-level output current	Q_H'	8		16		mA	
		Q_A thru Q_H , 'LS598 only	12		24			
f_{SCK}	Shift clock frequency	0		20	0		20	MHz
t_w	Pulse duration	SRCK	high	15		15		ns
			low	35		35		
		RCK		20		20		
		SRCLR		20		20		
		SRLOAD		40		40		
t_{su}	Setup time	Data before RCK ↑	20		20		ns	
		DS before SRCK ↑ ('LS598 only)	30		30			
		SRCKEN low before SRCK ↑ ('LS598 only)	20		20			
		SRCLR inactive before SRCK ↑	25		25			
		SRLOAD inactive before SRCK ↑	30		30			
		RCK ↑ before SRLOAD ↑ (see Note 2)	40		40			
t_h	Hold time	0		0		ns		
T_A	Operating free-air temperature	-55		125	0		70	°C

NOTE 2: The RCK ↑ before SRLOAD ↑ setup time ensures the data saved by RCK ↑ will also be loaded into the shift register.

TTL DEVICES 3

TYPES SN54LS597, SN54LS598, SN74LS597, SN74LS598

8-BIT SHIFT REGISTERS WITH INPUT LATCHES

electrical characteristics over recommended operating free-air temperature range (unless otherwise noted)

PARAMETER	TEST CONDITIONS [†]			SN54LS [†]		SN74LS [†]		UNIT	
				MIN	TYP‡	MAX	MIN		TYP‡
V _{IK}	V _{CC} = MIN, I _I = -18 mA			-1.5		-1.5		V	
V _{OH}	'LS598 Q	V _{CC} = MIN, V _{IH} = 2 V, V _{IL} = MAX	I _{OH} = -1 mA	2.4	3.2			V	
	Q _H [†]		I _{OH} = -2.6 mA			2.4	3.1		
			I _{OH} = -1 mA	2.4	3.2	2.4	3.2		
V _{OL}	'LS598 Q	V _{CC} = MIN, V _{IH} = 2 V, V _{IL} = MAX	I _{OL} = 12 mA	0.25 0.4		0.25	0.4	V	
	Q _H [†]		I _{OL} = 24 mA			0.35	0.5		
			I _{OL} = 8 mA	0.25 0.4					
			I _{OL} = 16 mA			0.35	0.5		
I _{OZH}	'LS598 Q	V _{CC} = MAX, V _O = 2.7 V, V _{IH} = 2 V, V _{IL} = MAX,			20		μA		
I _{OZL}	'LS598 Q	V _{CC} = MAX, V _O = 0.4 V, V _{IH} = 2 V, V _{IL} = MAX,	-0.4		-0.4		mA		
I _I	'LS598 Q	V _{CC} = MAX	V _I = 5.5 V	0.1		0.1		mA	
	Others		V _I = 7 V	0.1		0.1			
I _{IH}	V _{CC} = MAX, V _I = 2.7 V			20		20		μA	
I _{IL}	'LS598 SRCK	V _{CC} = MAX, V _I = 0.4 V			-0.8		-0.8		mA
	SER, A Thru H				-0.4		-0.4		
	Others				-0.2		-0.2		
I _{OS} §	'LS598 Q	V _{CC} = MAX, V _O = 0 V			-30	-130	-30	-130	mA
	Q _H [†]				-20	-100	-20	-100	
I _{CC}	'LS597	I _{CCH}			35	53	35	53	mA
		I _{CCL}	V _{CC} = MAX,		35	53	35	53	
	'LS598	I _{CCH}	All possible inputs grounded,		45	68	45	68	
		I _{CCL}	All outputs open		54	80	54	80	
		I _{CCZ}			56	85	56	85	

[†] For conditions shown as MIN or MAX, use the appropriate value specified under recommended operating conditions.

[‡] All typical values are at V_{CC} = 5 V, T_A = 25°C

[§] Not more than one output should be shorted at a time and the duration of the short-circuit should not exceed one second.

3

TTL DEVICES

TYPES SN54LS597, SN54LS598, SN74LS597, SN74LS598
8-BIT SHIFT REGISTERS WITH INPUT LATCHES

switching characteristics, $V_{CC} = 5\text{ V}$, $T_A = 25^\circ\text{C}$, (see note 3)

PARAMETER	FROM (INPUT)	TO (OUTPUT)	TEST CONDITIONS	'LS597			'LS598			UNIT	
				MIN	TYP	MAX	MIN	TYP	MAX		
f_{\max}	SRCK		$R_L = 1\text{ k}\Omega$, $C_L = 30\text{ pF}$	20	35		20	35		MHz	
t_{PLH}	SRCK \uparrow	Q_H'			15	23		11	17		ns
t_{PHL}	SRCK \uparrow	Q_H'			20	30		15	23		ns
t_{PLH}	SRLOAD \downarrow	Q_H'			38	57		28	42		ns
t_{PHL}	SRLOAD \downarrow	Q_H'			29	44		20	30		ns
t_{PHL}	SRCLR \downarrow	Q_H'			24	36		18	27		ns
t_{PLH}	RCK \uparrow	Q_H'	$R_L = 1\text{ k}\Omega$, $C_L = 30\text{ pF}$ SRLOAD = L	41	60		32	48		ns	
t_{PHL}	RCK \uparrow	Q_H'			32	48		24	36		ns
t_{PLH}	SRCK \uparrow	Q	$R_L = 667\ \Omega$, $C_L = 45\text{ pF}$				12	18		ns	
t_{PHL}	SRCK \uparrow	Q					19	28		ns	
t_{PLH}	SRLOAD \downarrow	Q					32	48		ns	
t_{PHL}	SRLOAD \downarrow	Q					27	40		ns	
t_{PHL}	SRCLR \downarrow	Q					25	38		ns	
t_{PZH}	G \downarrow	Q					26	31		ns	
t_{PZL}	G \downarrow	Q	$R_L = 667\ \Omega$, $C_L = 5\text{ pF}$				29	43		ns	
t_{PHZ}	G \uparrow	Q					25	38		ns	
t_{PLZ}	G \uparrow	Q					20	30		ns	

NOTE 3: See General Information Section for load circuits and voltage waveforms.

TYPES SN54LS597, SN54LS598, SN74LS597, SN74LS598 8-BIT SHIFT REGISTERS WITH INPUT LATCHES

typical operating sequences

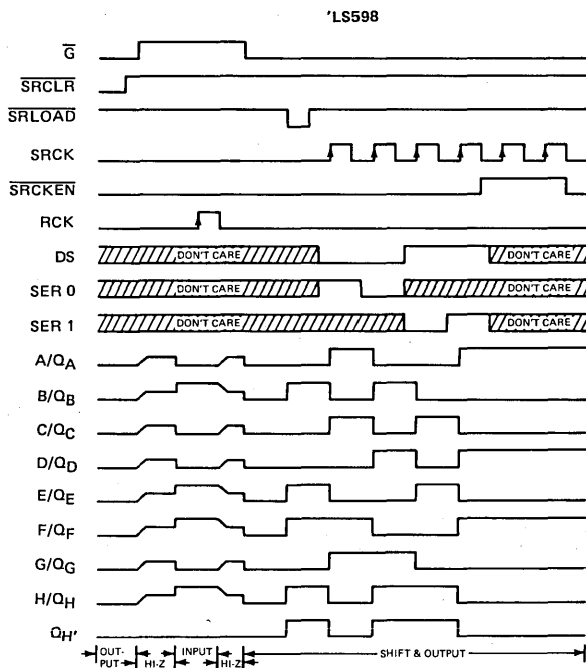
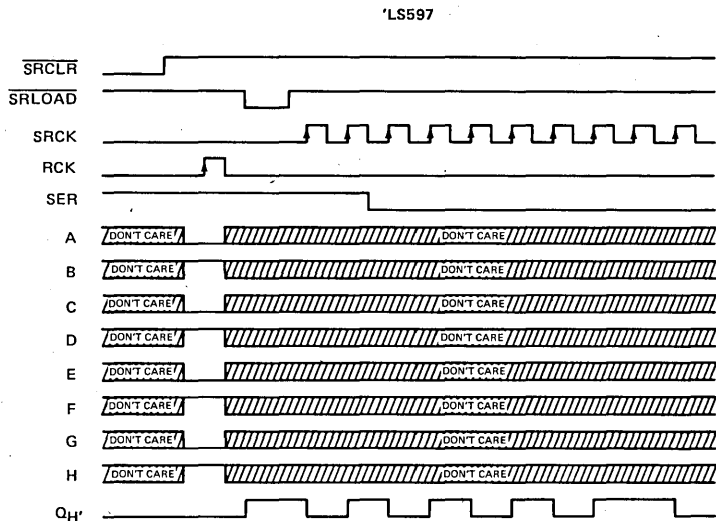

TYPES SN74LS600A THRU SN74LS603A MEMORY REFRESH CONTROLLERS

D2547, JANUARY 1981—REVISED JUNE 1983

- Controls Refresh Cycle of 4K, 16K, and 64K Dynamic RAMs
- Creates Static RAM Appearance
- Choice of Transparent, Cycle Steal, or Burst Refresh Modes
- 3-State Outputs Drive Bus Lines Directly
- Critical Times Are User RC-Programmable to Optimize System Performance

SN54LS^{*} ... J PACKAGE
SN74LS^{*} ... DW, J OR N PACKAGE
(TOP VIEW)

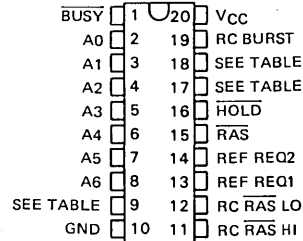

FOR CHIP CARRIER INFORMATION
CONTACT THE FACTORY

SELECTION TABLE

DEVICE	REFRESH MODES	MEMORY SIZE	PIN ASSIGNMENTS		
			PIN 9	PIN 17	PIN 18
'LS600A	Transparent, Burst	4K or 16K	4K/16K	LATCHED RCO	RESET LATCHED RCO
'LS601A	Transparent, Burst	64K	A7	LATCHED RCO	RESET LATCHED RCO
'LS602A	Cycle Steal, Burst	4K or 16K	4K/16K	READY	RC CYCLE STEAL
'LS603A	Cycle Steal, Burst	64K	A7	READY	RC CYCLE STEAL

description

The 'LS600A thru 'LS603A memory refresh controllers contain one 8-bit synchronous counter, nine 3-state buffer drivers, four RC-controlled multivibrators, and other control circuitry on a single monolithic chip. These devices are designed to provide RAS-only refresh on 4K, 16K, and 64K dynamic RAMs. The 'LS600A and 'LS601A provide transparent refresh while the 'LS602A and 'LS603A provide cycle-steal refresh. In addition, a burst-mode timer is provided to warn the CPU that the maximum allowable refresh time is about to be violated.

operating modes

In the transparent refresh mode ('LS600A or 'LS601A), row-refresh cycles occur only during inactive CPU-memory times. In most cases the entire memory refresh sequence can be completed "transparently" without interrupting CPU operations. During idle CPU-memory periods, the REF REQ pins should be taken high so as many rows as possible can be refreshed. A low from BUSY will signal the CPU to wait until the end of that current row refresh before reinstating operations. If all row addresses have been refreshed before the burst-mode timer expires, the burst-mode timer will reset.

If the maximum allowable refresh time of the dynamic RAM is about to be exceeded, the burst mode timer will expire causing the HOLD pin to go low. This signals the CPU that a burst-mode refresh is mandatory and the burst-mode refresh will be accomplished when the CPU takes the REF REQ pins high. To ensure that all rows are refreshed, the address counter is reset to zero whenever the burst-mode timer expires. After the last row has been refreshed, the HOLD pin will return high, and the burst-mode timer will reset. The CPU can then return to normal transparent operation.

A LATCHED RCO output pin is also provided on the 'LS600A and 'LS601A to detect when the last row has been refreshed. Upon seeing a RCO from the address counter, the LATCHED RCO output will be set high. This latch is reset by providing a high-going pulse on the RESET LATCHED RCO input.

In the cycle-steal refresh mode ('LS602A or 'LS603A), refreshing is accomplished by dividing the safe refresh time into equal segments and refreshing one row in each segment. The segment time is programmed via the RC CYCLE STEAL input and will produce a low level on the READY output at the end of each segment period. This indicates to the CPU to suspend operations for one memory cycle for a row refresh. In effect it "steals" one memory cycle from the CPU. After the CPU recognizes the cycle-steal signal from the READY output, it must take both REF REQ pins high. These devices will then refresh one row and return control back to the CPU by taking READY high. The burst-mode timer is also provided to prevent exceeding the maximum allowable refresh time, and operates in the same manner as in the 'LS600A and 'LS601A. In applications where the burst-mode timer is not required, it can be disabled by connecting the RC Burst input to ground.

PRODUCTION DATA

This document contains information current as of publication date. Products conform to specifications per the terms of Texas Instruments standard warranty. Production processing does not necessarily include testing of all parameters.

Copyright © 1983 by Texas Instruments Incorporated

TEXAS
INSTRUMENTS

POST OFFICE BOX 225012 • DALLAS, TEXAS 75265

3-1167

TTL DEVICES

TYPES SN74LS600A, SN74LS601A MEMORY REFRESH CONTROLLERS

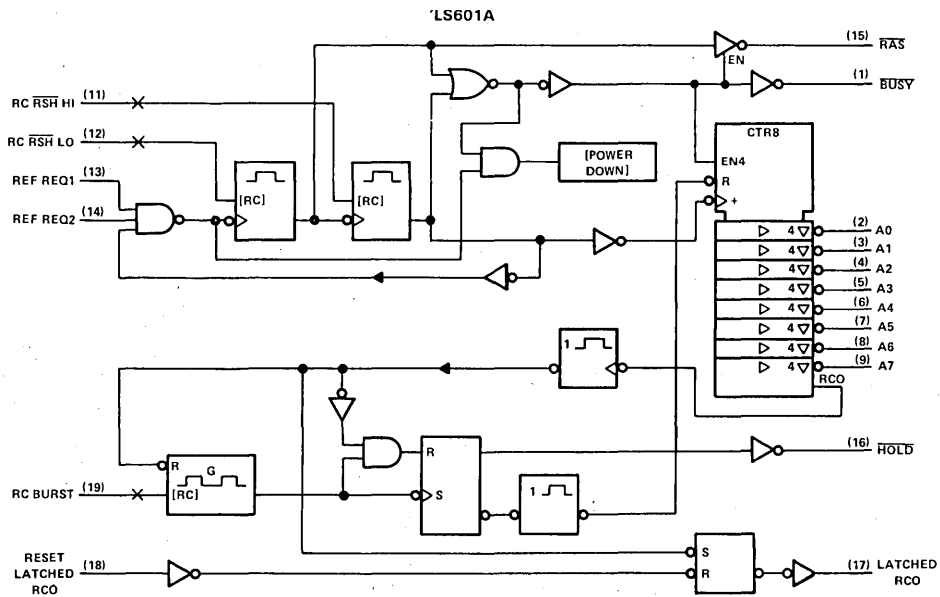
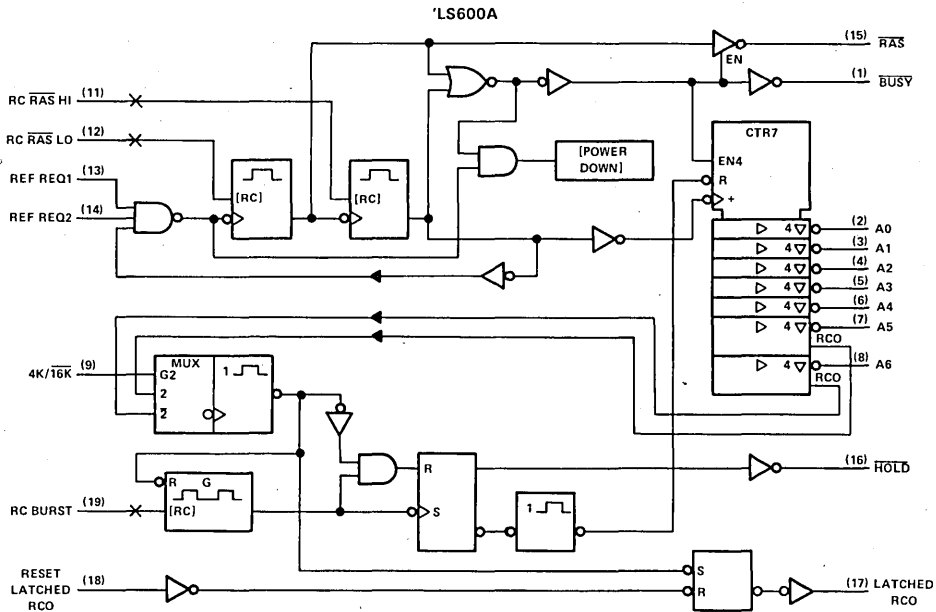

Pin numbers shown on logic notation are for DW, J or N packages.

3 TTL DEVICES

TYPES SN74LS602A, SN74LS603A MEMORY REFRESH CONTROLLERS

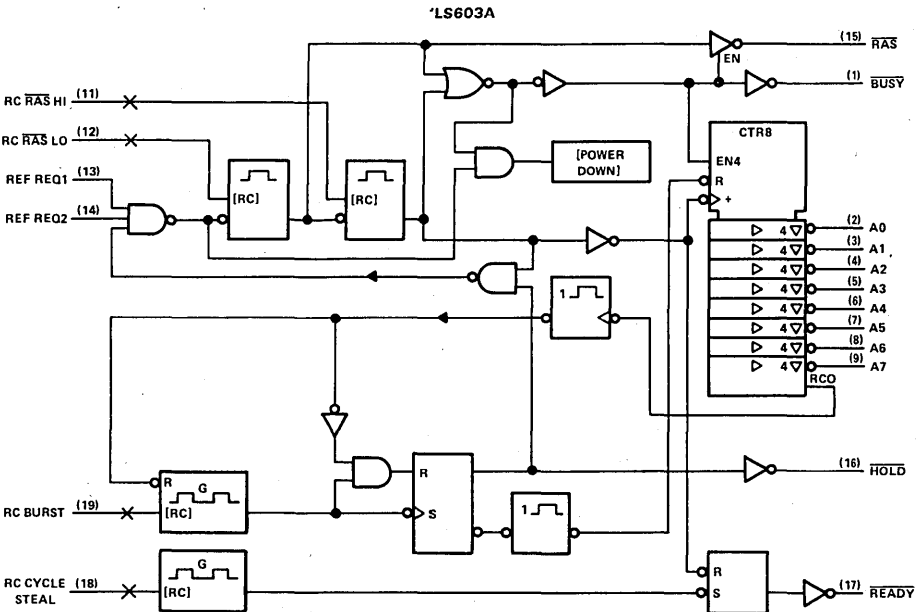
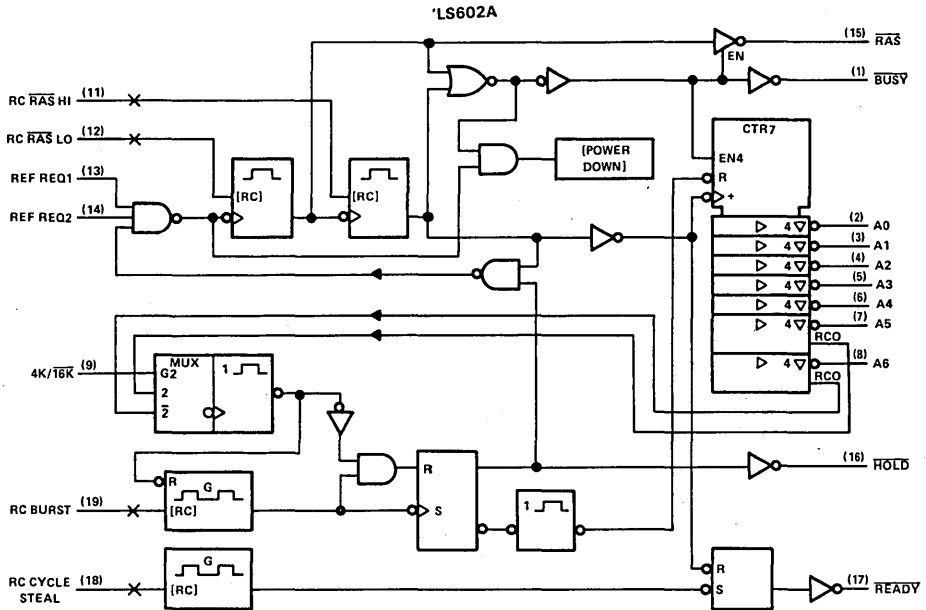

Pin numbers shown on logic notation are for DW, J or N packages.

3
TTL DEVICES

TYPES SN74LS600A THRU SN74LS603A MEMORY REFRESH CONTROLLERS

recommended operating conditions

		MIN	NOM	MAX	UNIT
Supply voltage, V_{CC}		4.75	5	5.25	V
High-level output current, I_{OH}	A, \overline{RAS}			-2.6	mA
	All others			-400	μ A
Low-level output current, I_{OL}	A, \overline{RAS}			24	mA
	All others			8	
Duration or \overline{RAS} output pulse [†]	High, t_{SHSL}	75			ns
	Low, t_{SLSH}	75			
Duration of RESET LATCHED RCO pulse, t_{RHRL}		35			ns
Duration of REF REQ pulse during CYCLE STEAL operation, t_{QHQL}		20			ns
External timing resistor, R_{ext}	RC \overline{RAS} LO, RC \overline{RAS} HI	1		6	k Ω
	RC BURST, RC CYCLE STEAL	1		1000	
Operating free-air temperature, T_A		0		70	$^{\circ}$ C

[†]Maximum operating frequency for the address counter corresponds to its minimum period, which is the sum of $t_{w(RAS-H)}$ min and $t_{w(RAS-L)}$ min.

electrical characteristics over recommended operating free-air temperature range (unless otherwise noted)

PARAMETER		TEST CONDITIONS		MIN	TYP [‡]	MAX	UNIT
V_{IH}	High-level input voltage			2			V
V_{IL}	Low-level input voltage					0.8	V
V_{IK}	Input clamp voltage	$V_{CC} = 4.75$ V, $I_I = -1.8$ mA				-1.5	V
V_{OH}	High-level output voltage	A, \overline{RAS}	$V_{CC} = 4.75$ V, $V_{IH} = 2$ V, $V_{IL} = 0.8$ V	$I_{OH} = -2.6$ mA	2.4	2.9	V
		All Others		$I_{OH} = -400$ μ A	2.7	3.1	
V_{OL}	Low-level output voltage	A, \overline{RAS}	$V_{CC} = 4.75$ V, $V_{IH} = 2$ V, $V_{IL} = 0.8$ V	$I_{OL} = 12$ mA	0.25	0.4	V
				$I_{OL} = 24$ mA	0.35	0.5	
		All Others		$I_{OL} = 4$ mA	0.25	0.4	
				$I_{OL} = 8$ mA	0.35	0.5	
I_{OZH}	Off-state output current, high-level voltage applied	A, \overline{RAS}	$V_{CC} = 5.25$ V REF REQ at $V_{IL} = 0.8$ V	$V_O = 2.7$ V		20	μ A
I_{OZL}	Off-state output current, low-level voltage applied			$V_O = 0.4$ V		-20	μ A
I_I	Input current at maximum input voltage	$V_{CC} = 5.25$ V, $V_I = 7$ V			0.1		mA
I_{IH}	High-level input current	$V_{CC} = 5.25$ V, $V_I = 2.7$ V				20	μ A
I_{IL}	Low-level input current	$V_{CC} = 5.25$ V, $V_I = 0.4$ V				-0.4	mA
I_{OS}	Short-circuit output current [§]	A, \overline{RAS}	$V_{CC} = 5.25$ V		-30	-130	mA
		All others				-20	
I_{CC}	Supply current	$V_{CC} = 5.25$ V, RC \overline{RAS} LO and REF REQ at 0 V			50	85	mA

[‡]All typical values are at $V_{CC} = 5$ V, $T_A = 25^{\circ}$ C.

[§]Not more than one output should be shorted at a time, and duration of the short-circuit should not exceed one second.

3

TTL DEVICES

TYPES SN74LS600A THRU SN74LS603A MEMORY REFRESH CONTROLLERS

switching characteristics, $V_{CC} = 5\text{ V}$, $T_A = 25^\circ\text{C}$, see note 3

PARAMETER	FROM (INPUT)	TO (OUTPUT)	TEST CONDITIONS	MIN	TYP	MAX	UNIT
t_{QHBL}	REF REQ1	$\overline{\text{BUSY}}$	$C_L = 15\text{ pF}$, $R_L = 2\text{ k}\Omega$	30	45		ns
t_{SLBH}^\dagger	RAS1	BUSY		245	300		ns
t_{QHSV}	REF REQ1	RAS	$C_L = 320\text{ pF}$, $R_L = 667\Omega$	47	70		ns
t_{SHSZ}^\ddagger	RAS1	RAS		245	300		ns
t_{QHAV}	REF REQ1	ADDRESS	$C_L = 160\text{ pF}$, $R_L = 667\Omega$	38	65		ns
t_{SHAZ}^\ddagger	RAS1	ADDRESS		245	300		ns
t_{RHCL}	RESET LATCHED	LATCHED	$C_L = 15\text{ pF}$, $R_L = 2\text{ k}\Omega$	37	55		ns
	RCO1	RCO					
t_{SHYH}	RAS1	READY	$C_L = 320\text{ pF}$, $R_L = 667\Omega$	64	85		ns
t_{SLSH}^\ddagger	RAS1	RAS		210			ns
t_{SHSL}^\ddagger	RAS1	RAS	$C_L = 320\text{ pF}$, $R_L = 667\Omega$	245			ns
t_{DHDL}^\S	HOLD1	HOLD		3.56			ms
t_{YLYL}^\P	READY1	READY	$C_L = 15\text{ pF}$, $R_L = 2\text{ k}\Omega$	27			μs

[†] Depends on RC network at pin 11 (4 k Ω , 200 pF used for testing).

[‡] Depends on RC network at pin 12 (4 k Ω , 200 pF used for testing).

[§] Depends on RC network at pin 19 (680 k Ω , 0.022 μF used for testing).

[¶] Depends on RC network at pin 18 (10 k Ω , 0.01 μF used for testing).

NOTE 3: See General Information Section for load circuits and voltage waveforms.

explanation of letter symbols

This data sheet uses a new type of letter symbol to describe time intervals. The format is:

t_{AB-CD}

where: subscripts A and C indicate the names of the signals for which changes of state or level or establishment of state or level constitute signal events assumed to occur first and last, respectively, that is, at the beginning and end of the time interval.

Subscripts B and D indicate the direction of the transitions and/or the final states or levels of the signals represented by A and C, respectively. One or two of the following is used:

- H = high or transition to high
- L = low or transition to low
- V = a valid steady-state level
- X = unknown, changing, or "don't care" level
- Z = high-impedance (off) state.

The hyphen between the B and C subscripts is omitted when no confusion is likely to occur. For these letter symbols on this data sheet, the signal names are further abbreviated as follows:

SIGNAL NAME	A or C SUBSCRIPT
$\overline{\text{BUSY}}$	B
HOLD	D
RAS	S
A0 - A7	A
READY	Y
LATCHED RCO	C
RESET LATCHED RCO	R
REF REQ	Q

TIMING DIAGRAMS

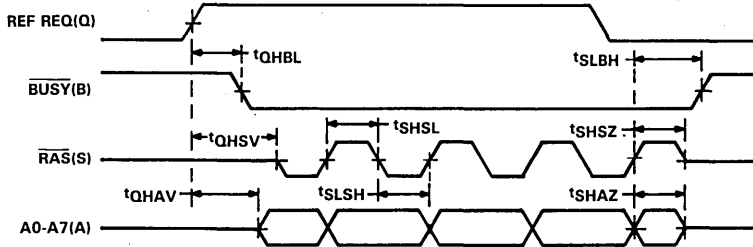

FIGURE 1 - TRANSPARENT REFRESH

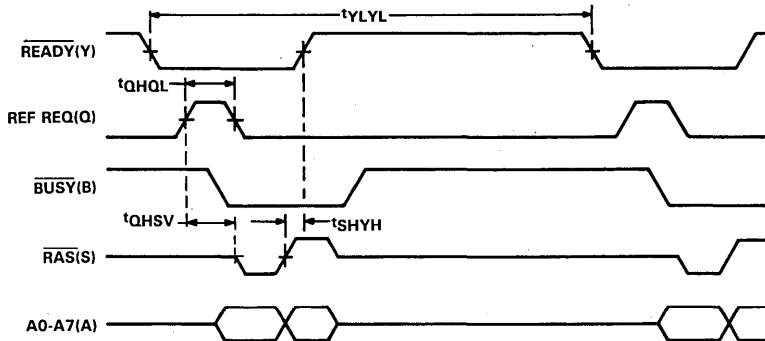
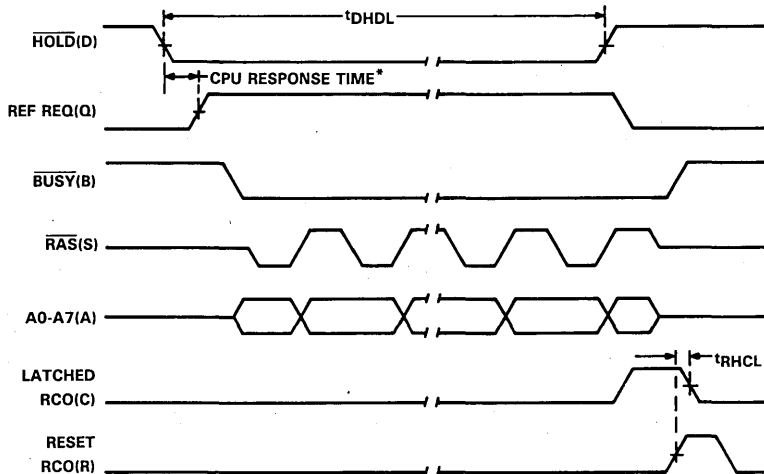

FIGURE 2 - CYCLE STEAL REFRESH



* During testing, an 'LS04 is used to invert $\overline{\text{HOLD}}$ to provide the REF REQ input.

FIGURE 3 - BURST MODE REFRESH

**TYPES SN74LS600A THRU SN74LS603A
MEMORY REFRESH CONTROLLERS**

TYPICAL CHARACTERISTICS

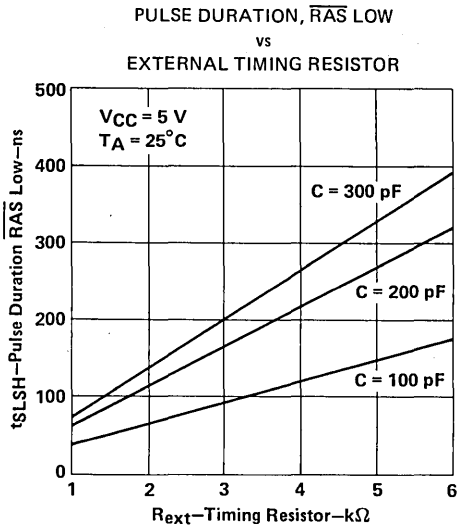

FIGURE 4

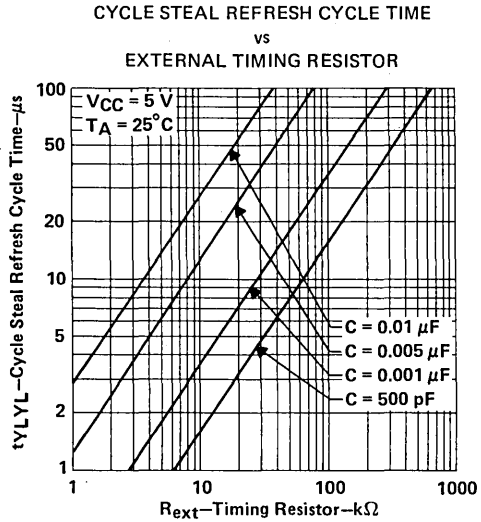

FIGURE 5

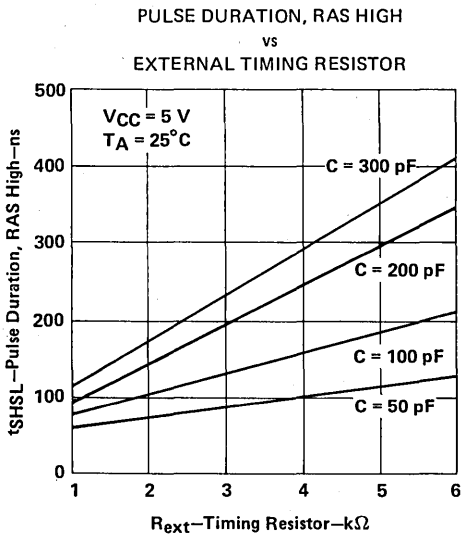

FIGURE 6

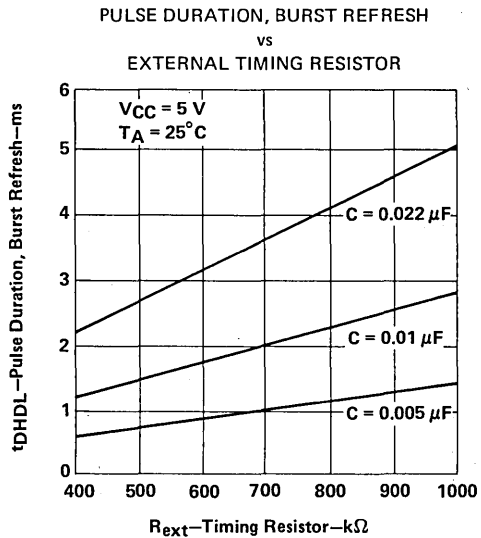

FIGURE 7

3

TTL DEVICES

TYPES SN54LS604 THRU SN54LS607, SN74LS604 THRU SN74LS607 OCTAL 2-INPUT MULTIPLEXED LATCHES

D2545, JULY 1979 — REVISED DECEMBER 1983

(TIM99604 THRU TIM99607)

- **Choice of Outputs:**
Three-State ('LS604, 'LS606)
Open-Collector ('LS605, 'LS607)
- **16 D-Type Registers, One for each Data Input**
- **Multiplexer Selects Stored Data from Either A Bus or B Bus**
- **Application Oriented:**
Maximum Speed ('LS604, 'LS605)
Glitch-Free Operation ('LS606, 'LS607)

SN54LS604 thru SN54LS607 ... JD PACKAGE
SN74LS604 thru SN74LS607 ... JD OR N PACKAGE
(TOP VIEW)

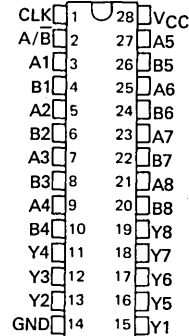

description

The 'LS604 through 'LS607 multiplexed latches are ideal for storing data from two input buses, A and B, and providing the output bus with stored data from either the A or B register.

The clock loads data on the positive-going (low-level to high-level) transition. The clock pin also controls the active and high-impedance states of the outputs. When the clock pin is low, the outputs are in the high-impedance or off state. When the clock pin is high, the outputs are enabled.

The 'LS604 and 'LS605 are optimized for high-speed operation. The 'LS606 and 'LS607 are especially designed to eliminate decoding voltage spikes.

These functions are ideal for interface from a 16-bit microprocessor to a 64K RAM board. The row and column addresses can be loaded as one word from the microprocessor and then multiplexed sequentially to the RAM during the time that RAS and CAS are active.

The SN54LS604 through SN54LS607 are characterized for operation over the full military temperature range of -55°C to 125°C ; the SN74LS604 through SN74LS607 are characterized for operation from 0°C to 70°C .

SN54LS604 thru SN54LS607 ... FK PACKAGE
SN74LS604 thru SN74LS607 ... FN PACKAGE
(TOP VIEW)

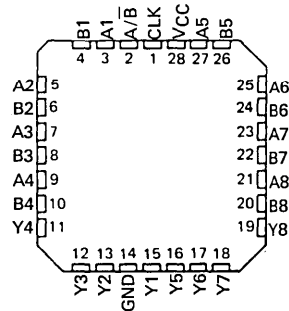

FUNCTION TABLE

INPUTS				OUTPUTS
A1-A8	B1-B8	SELECT A/B	CLOCK	Y1-Y8
A data	B data	L	↑	B data
A data	B data	H	↑	A data
X	X	X	L	Z or Off
X	X	L	H	B register stored data
X	X	H	H	A register stored data

H = high level (steady state)

L = low level (steady state)

X = irrelevant

Z = high-impedance state

Off = H if pull-up resistor is connected to open-collector output

↑ = transition from low to high level

PRODUCTION DATA

This document contains information current as of publication date. Products conform to specifications per the terms of Texas Instruments standard warranty. Production processing does not necessarily include testing of all parameters.

TEXAS
INSTRUMENTS

POST OFFICE BOX 225012 • DALLAS, TEXAS 75265



TTL DEVICES

TYPES SN54LS604 THRU SN54LS607, SN74LS604 THRU SN74LS607 OCTAL 2-INPUT MULTIPLEXED LATCHES

schematics of inputs and outputs

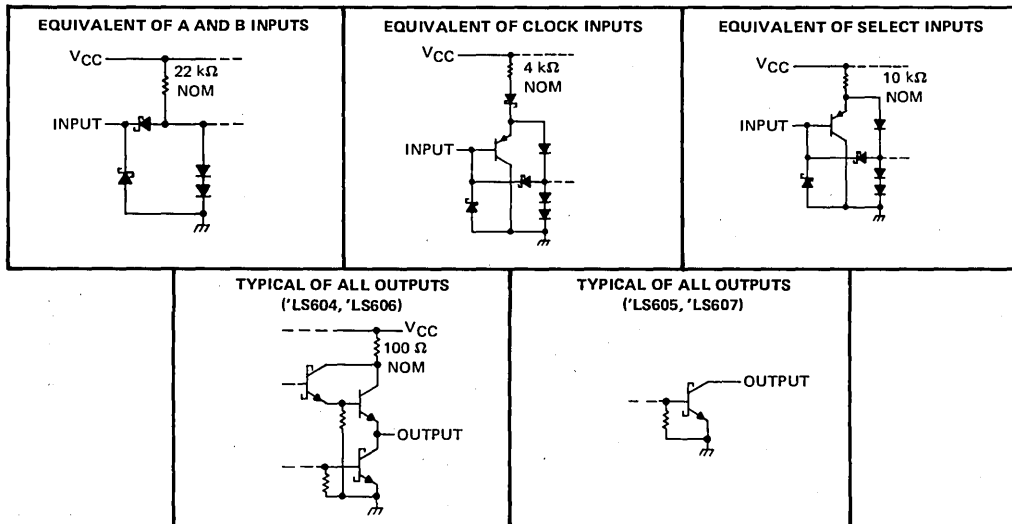

logic symbols

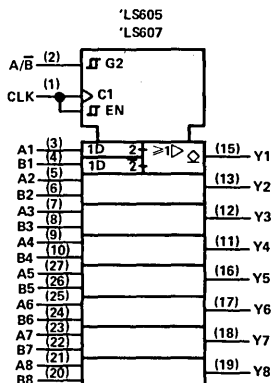
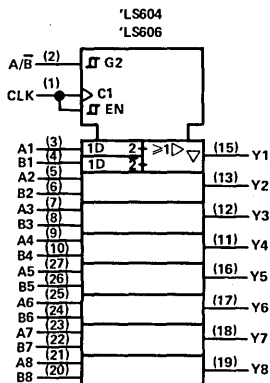

Pin numbers shown on logic notation are for JD or N packages.

TYPES SN54LS604 THRU SN54LS607, SN74LS604 THRU SN74LS607
OCTAL 2-INPUT MULTIPLEXED LATCHES

logic diagram (positive logic)

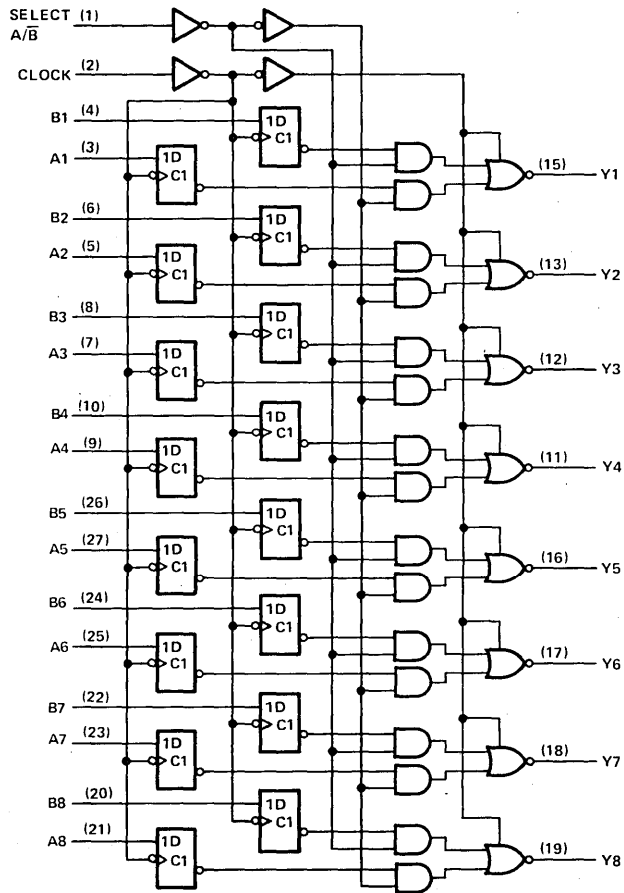

TYPES SN54LS604, SN54LS606, SN74LS604, SN74LS606

OCTAL 2-INPUT MULTIPLEXED LATCHES WITH 3-STATE OUTPUTS

recommended operating conditions

	SN54LS604 SN54LS606			SN74LS604 SN74LS606			UNIT
	MIN	NOM	MAX	MIN	NOM	MAX	
Supply voltage, V_{CC} (see Note 1)	4.5	5	5.5	4.75	5	5.25	V
High-level output current, I_{OH}			-1			-2.6	mA
Low-level output current, I_{OL}			12			24	mA
Width of clock pulse, t_w	20			20			ns
Setup time, t_{su}	20†			20†			ns
Hold time, t_h	0†			0†			ns
Operating free-air temperature, T_A	-55	125		0		70	°C

NOTE 1: Voltage values are with respect to network ground terminal.

electrical characteristics over recommended operating free-air temperature range (unless otherwise noted)

PARAMETER	TEST CONDITIONS†	SN54LS604 SN54LS606		SN74LS604 SN74LS606		UNIT
		MIN	TYP‡	MAX	MIN	
V_{IH}	High-level input voltage	2		2		V
V_{IL}	Low-level input voltage	0.7		0.8		V
V_{IK}	Input clamp voltage	-1.5		-1.5		V
V_{OH}	High-level output voltage	2.4	3.1	2.4	3.1	V
V_{OL}	Low-level output voltage	0.25	0.4	0.25	0.4	V
I_{OZH}	Off-state output current, high-level voltage applied	20		20		µA
I_{OZL}	Off-state output current, low-level voltage applied	-20		-20		µA
I_I	Input current at maximum input voltage	0.1		0.1		mA
I_{IH}	High-level input current	20		20		µA
I_{IL}	Low-level input current	-0.4		-0.4		mA
I_{OS}	Short-circuit output current§	-30	-130	-30	-130	mA
I_{CC}	Supply current	55	70	55	70	mA

† For conditions shown as MIN or MAX, use the appropriate value specified under recommended operating conditions.

‡ All typical values are at $V_{CC} = 5$ V, $T_A = 25^\circ$ C.

§ Note more than one output should be shorted at a time, and duration of the short-circuit should not exceed one second.

NOTE 2: I_{CC} is tested with all inputs grounded and all outputs open.

switching characteristics, $V_{CC} = 5$ V, $T_A = 25^\circ$ C

PARAMETER	FROM (INPUT)	TEST CONDITIONS	'LS604		'LS606		UNIT
			MIN	TYP	MAX	MIN	
t_{PLH}	Select A/B (Data: A = H, B = L)	$C_L = 45$ pF, $R_L = 667 \Omega$, See Note 3	15	25	36	50	ns
t_{PHL}			23	35	16	30	
t_{PLH}	Select A/B (Data: A = L, B = H)		31	45	22	35	ns
t_{PHL}			19	30	22	35	
t_{PZH}	Clock		19	30	27	40	ns
t_{PZL}			28	40	35	50	
t_{PHZ}	Clock	20	30	20	30	ns	
t_{PLZ}		15	25	15	25		

t_{PLH} = propagation delay time, low-to-high-level output

t_{PHL} = propagation delay time, high-to-low-level output

t_{PZH} = output enable time to high level

t_{PZL} = output enable time to low level

t_{PHZ} = output disable time from high level

t_{PLZ} = output disable time from low level

NOTE 3: See General Information Section for load circuits and voltage waveforms.

TYPES SN54LS605, SN54LS607, SN74LS605, SN74LS607

OCTAL 2-INPUT MULTIPLEXED LATCHES WITH OPEN-COLLECTOR OUTPUTS

recommended operating conditions

	SN54LS605 SN54LS607			SN74LS605 SN74LS607			UNIT
	MIN	NOM	MAX	MIN	NOM	MAX	
Supply voltage, V_{CC} (see Note 1)	4.5	5	5.5	4.75	5	5.25	V
High-level output voltage, V_{OH}			5.5			5.5	V
Low-level output current, I_{OL}			12			24	mA
Width of clock pulse, t_w	20			20			ns
Setup time, t_{SU}	20†			20†			ns
Hold time, t_h	0†			0†			ns
Operating free-air temperature, T_A	-55	125		0		70	°C

NOTE 1: Voltage values are with respect to network ground terminal.

electrical characteristics over recommended operating free-air temperature range (unless otherwise noted)

PARAMETER	TEST CONDITIONS†	SN54LS605 SN54LS607			SN74LS605 SN74LS607			UNIT
		MIN	TYP‡	MAX	MIN	TYP‡	MAX	
V_{IH} High-level input voltage		2			2			V
V_{IL} Low-level input voltage				0.7			0.8	V
V_{IK} Input clamp voltage	$V_{CC} = \text{MIN}, I_I = -18 \text{ mA}$			-1.5			-1.5	V
I_{OH} High-level output current	$V_{CC} = \text{MIN}, V_{IH} = 2 \text{ V}, V_{IL} = V_{IL \text{ max}}, V_{OH} = 5.5 \text{ V}$			250			250	μA
V_{OL} Low-level output voltage	$V_{CC} = \text{MIN}, V_{IH} = 2 \text{ V}, V_{IL} = V_{IL \text{ max}}$	$I_{OL} = 12 \text{ mA}$	0.25	0.4	0.25	0.4	V	
		$I_{OL} = 24 \text{ mA}$			0.35	0.5		
I_I Input current at maximum input voltage	$V_{CC} = \text{MAX}, V_I = 7 \text{ V}$	A, B		0.1		0.1	mA	
		CLK, SELECT		0.1		0.1		
		A, B		20		20		
I_{IH} High-level input current	$V_{CC} = \text{MAX}, V_I = 2.7 \text{ V}$	CLK, SELECT		20		20	μA	
		A, B		-0.4		-0.4		
I_{IL} Low-level input current	$V_{CC} = \text{MAX}, V_I = 0.4 \text{ V}$	A, B		-0.4		-0.4	mA	
		CLK, SELECT		-0.2		-0.2		
I_{CC} Supply current	$V_{CC} = \text{MAX},$ See Note 2		40	60		40	60	mA

† For conditions shown as MIN or MAX, use the appropriate value specified under recommended operating conditions.

‡ All typical values are at $V_{CC} = 5 \text{ V}, T_A = 25^\circ \text{C}$.

NOTE 2: I_{CC} is tested with all inputs grounded and all outputs open.

switching characteristics, $V_{CC} = 5 \text{ V}, T_A = 25^\circ \text{C}$

PARAMETER	FROM (INPUT)	TEST CONDITIONS	'LS605			'LS607			UNIT
			MIN	TYP	MAX	MIN	TYP	MAX	
t_{PLH}	Select A/B	$C_L = 45 \text{ pF}, R_L = 667 \Omega,$ See Note 3	28	40		51	70	ns	
t_{PHL}	(Data: A = H, B = L)		28	40		21	30		
t_{PLH}	Select A/B		39	60		28	40	ns	
t_{PHL}	(Data: A = L, B = H)		25	40		28	40		
t_{PLH}	Clock		27	40		30	45	ns	
t_{PHL}			25	40		32	45		

t_{PLH} = propagation delay time, low-to-high-level output

t_{PHL} = propagation delay time, low-to-low-level output

NOTE 3: See General Information Section for load circuits and voltage waveforms.

TYPES SN54LS608, SN74LS608 (TIM99608) MEMORY CYCLE CONTROLLERS

D2548, JANUARY 1981 — REVISED DECEMBER 1981

- Provides Correct Timing for Memory Cycles
 - Read Cycle
 - Write Cycle
 - Read-Modify-Write Cycle
 - RAS-Only Refresh Cycle
- Page or Normal Modes
- Stand-Alone Controller for CPU-to-Memory Interface
- Also Designed to be Part of a Three-Chip Set Consisting of 'LS600 thru 'LS603, 'LS604 thru 'LS607, and 'LS608
- RAS Output is 3-State to Share Bus With 'LS600 thru 'LS603
- Critical Times Are User RC-Programmable to Optimize System Performance

description

The 'LS608 memory cycle controller is designed to interface between a microprocessor and dynamic RAM memories. It contains six RS latches, five D-type flip-flops, and more than 50 miscellaneous gates on a single chip. The 'LS608 combines maximum flexibility and ease of programming via RC nodes to allow optimum memory cycle performance.

The 'LS608 can operate as a stand-alone interface but it is also designed to be part of a three-chip memory controller set. The user must select one of the 'LS600 thru 'LS603 refresh controllers and one of the 'LS604 thru 'LS607 multiplexers to use along with the 'LS608 memory cycle controller for complete dynamic RAM control.

After the user has selected and attached RC networks to pins 1, 12, and 15, the 'LS608 will deliver proper RAS, CAS, and READ/WRITE output signals to execute one memory cycle as the start input is switched from low to high. The actual cycle executed will depend upon steady-state input conditions of the 'LS608 as indicated in the table below.

MEMORY CYCLE	MODE	INPUT CONDITIONS						
		P/N IN	R/W IN	RMW IN	RAS ENABLE IN	CAS HOLD IN	START IN	REFRESH IN
READ	PAGE	H	H	H	L	H	↑	L
WRITE		H	L	H	L	H	↑	L
READ-MODIFY-WRITE		H	H	L	L	H	↑	L
READ	NORMAL	L	H	H	L	H	↑	L
WRITE		L	L	H	L	H	↑	L
READ-MODIFY-WRITE		L	H	L	L	H	↑	L
REFRESH	REFRESH	x	x	x	L	H	↑	H
EXTERNAL REFRESH		x	x	x	H	H	x	L

H = High, L = Low, x = Irrelevant, ↑ = low-to-high transition

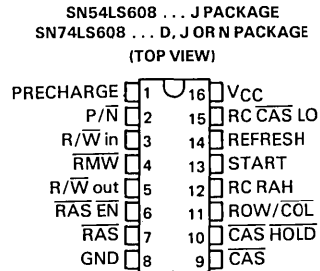

SN54LS608 ... FK PACKAGE
SN74LS608 ... FN PACKAGE
(TOP VIEW)

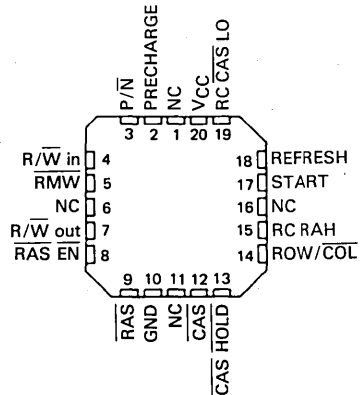

NC - No internal connection

PRODUCTION DATA

This document contains information current as of publication date. Products conform to these specifications per the terms of Texas Instruments standard warranty. Production processing does not necessarily include testing of all parameters.

TEXAS
INSTRUMENTS

POST OFFICE BOX 225012 • DALLAS, TEXAS 75265

3-1181

**TYPES SN54LS608, SN74LS608
MEMORY CYCLE CONTROLLERS**

PIN FUNCTION TABLE

PIN	PIN NAME	FUNCTIONAL DESCRIPTION
1	RC PRECHARGE	User-programmable timing node* for precharge ($\overline{\text{CAS}}$ high and $\overline{\text{RAS}}$ high).
2	$\text{P}/\overline{\text{N}}$ IN	When high, initiates a ready cycle (holds R/W OUT high) and, when low, page mode read or write cycle holds $\overline{\text{RAS}}$ continuously low while $\overline{\text{CAS}}$ and column addresses are sequenced.
3	$\text{R}/\overline{\text{W}}$ IN	When high, initiates a ready cycle (holds $\text{R}/\overline{\text{W}}$ OUT high) and, when low, initiates a write cycle (holds $\text{R}/\overline{\text{W}}$ OUT low) if pin 4 is high and pin 14 is low.
4	$\overline{\text{RMW}}$ IN	When low, enables read-modify-write cycle. $\text{R}/\overline{\text{W}}$ IN must be high at the start of the RMW cycle.
5	$\text{R}/\overline{\text{W}}$ OUT	When high, indicates a read cycle is in progress. When low, indicates a write cycle is in progress. Normally ties to a $\overline{\text{W}}$ memory input in a system.
6	$\overline{\text{RAS}}$ ENABLE IN	When low, enables $\overline{\text{RAS}}$ output. When high, $\overline{\text{RAS}}$ is in the high-impedance or third state.
7	$\overline{\text{RAS}}$ OUT	3-state row-address-strobe output controlled by $\overline{\text{RAS}}$ ENABLE IN. In the three-chip controller set, the $\overline{\text{RAS}}$ output of the 'LS608 ties to the $\overline{\text{RAS}}$ output of the refresh controller ('LS600 thru 'LS603).
8	GND	Device and substrate ground.
9	$\overline{\text{CAS}}$ OUT	Column-address-strobe output.
10	$\overline{\text{CAS}}$ HOLD IN	When low, allows $\overline{\text{CAS}}$ to latch in low state. When high, latch is removed. Can be used to improve data retrieval during read cycle.
11	ROW/COL (or MEMBSY) OUT	In a system where the 'LS608 is a stand-alone controller, this output indicates a memory-busy condition to the microprocessor. When the 'LS608 is used as a part of a three-chip controller set, this pin ties to the SELECT A/B input of the multiplexer ('LS604 thru 'LS607) for selecting row and column in addition to indicating a memory-busy condition to the microprocessor.
12	RC RAH	User-programmable timing node* for row address hold time. (high level at ROW/COL OUT).
13	START IN	When changed from low to high, initiates a memory cycle.
14	REFRESH IN	When high, enables $\overline{\text{RAS}}$ -only refresh cycle.
15	RC $\overline{\text{CAS}}$ LO	User-programmable timing node* for column-address-strobe low time.
16	VCC	5-volt power supply terminal.

*All timing nodes require a resistor to V_{CC} and a capacitor to ground. Programmed time is approximately 0.29 RC.

3 TTL DEVICES

TYPES SN64LS608, SN74LS608
MEMORY CYCLE CONTROLLERS

Logic diagram (positive logic)

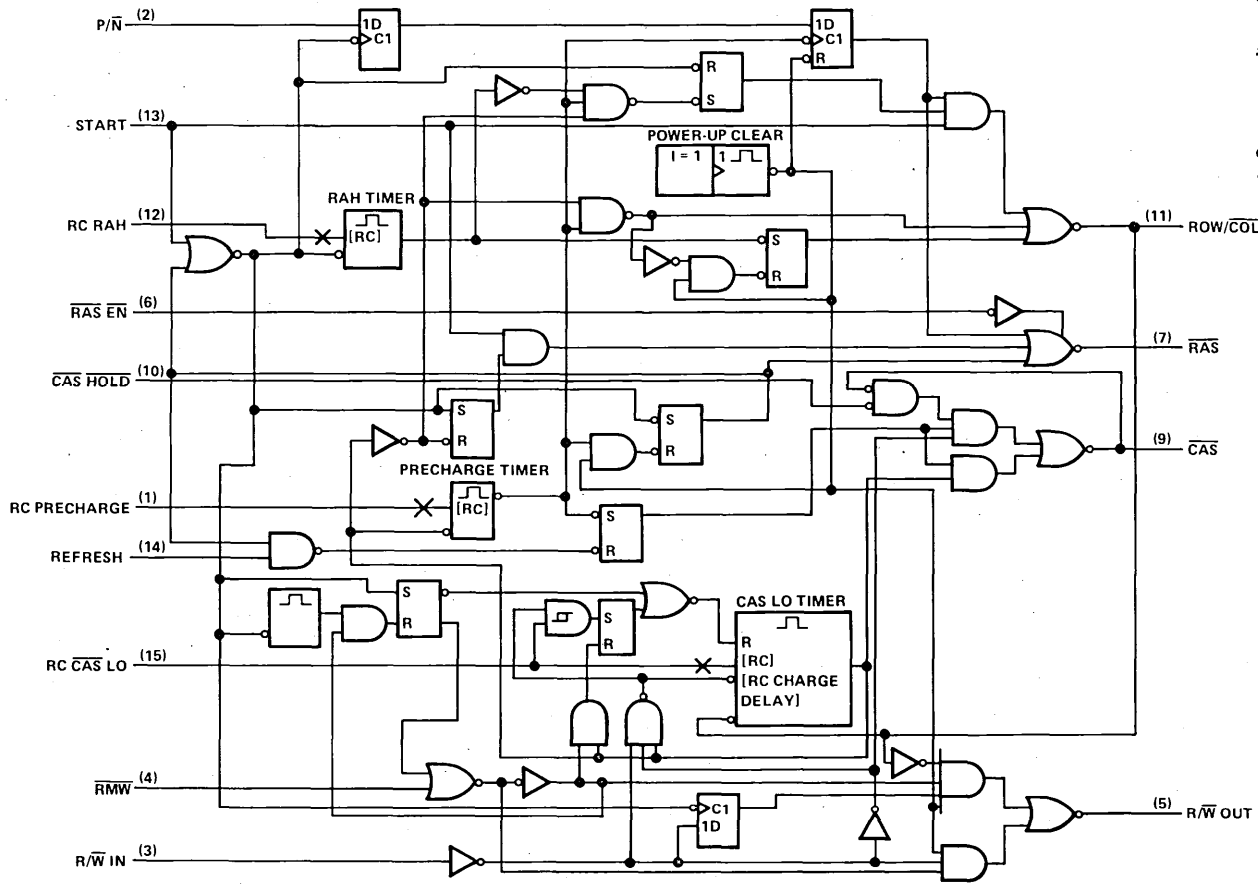

Pin numbers shown on logic notation are for D, J or N packages.

**TYPES SN54LS608, SN74LS608
MEMORY CYCLE CONTROLLERS**

schematics of inputs and outputs

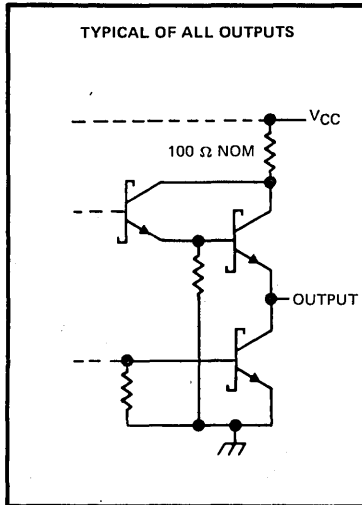
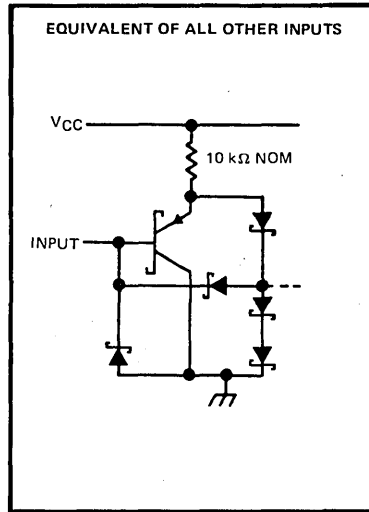
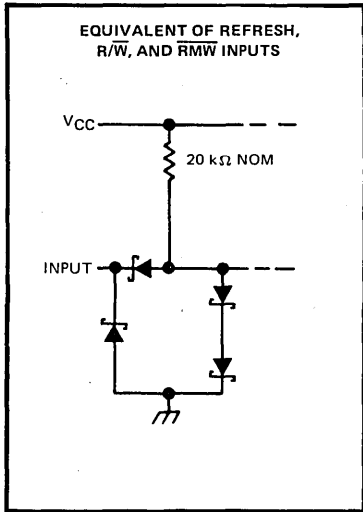

3

TTL DEVICES

TYPES SN54LS608, SN74LS608 MEMORY CYCLE CONTROLLERS

absolute maximum ratings over operating free-air temperature range (unless otherwise noted)

Supply voltage, V_{CC} (see Note 1)	7 V
Input voltage	7 V
Off-state output voltage	5.5 V
Operating free-air temperature range: SN54LS608	-55°C to 125°C
SN74LS608	0°C to 70°C
Storage temperature range	-65°C to 150°C

NOTE 1: Voltage values are with respect to the network ground terminal.

recommended operating conditions

		SN54LS608			SN74LS608			UNIT		
		MIN	NOM	MAX	MIN	NOM	MAX			
V_{CC}	Supply voltage	4.5	5	5.5	4.75	5	5.25	V		
V_{IH}	High-level input voltage	2			2			V		
V_{IL}	Low-level input voltage			0.7			0.8	V		
I_{OH}	High-level output current	ROW/COL		-0.4			-0.4	mA		
		RAS		-1			-2.6			
		All others		-1.2			-1.2			
I_{OL}	Low-level output current	ROW/COL		4			8	mA		
		All others		12			24			
t_{su}	Setup time	R/W, RMW, P/N, or REFRESH to START †		20			20	ns		
		CAS HOLD to CAS ‡		20			20			
t_h	Hold time		0			0		ns		
R_{ext}	External timing resistor	RC RAH		0.1		2	0.1	2	kΩ	
		RC CAS LO, RC PRECHARGE		1		6	1	6		
T_A	Operating free-air temperature		-55			125		0	70	°C

electrical characteristics over recommended operating free-air temperature range (unless otherwise noted)

PARAMETER		TEST CONDITIONS†		SN54LS608			SN74LS608			UNIT
				MIN	TYP‡	MAX	MIN	TYP‡	MAX	
V_{IK}		$V_{CC} = \text{MIN}$	$I_I = -18 \text{ mA}$			-1.5			-1.5	V
V_{OH}	ROW/COL	$V_{CC} = \text{MIN},$ $V_{IL} = \text{MAX}$	$V_{IH} = 2 \text{ V},$	$I_{OH} = -400 \mu\text{A}$	2.5	3.4	2.7	3.4	V	
	RAS			$I_{OH} = \text{MAX}$	2.4	3.2	2.4	3.1		
	Others			$I_{OH} = -1.2 \text{ mA}$	2.4	3.2	2.4	3.2		
V_{OL}	ROW/COL	$V_{CC} = \text{MIN},$ $V_{IL} = \text{MAX}$	$V_{IH} = 2 \text{ V},$	$I_{OL} = 4 \text{ mA}$		0.25	0.4	0.25	0.4	V
				$I_{OL} = 8 \text{ mA}$				0.35	0.5	
				$I_{OL} = 12 \text{ mA}$		0.25	0.4	0.25	0.4	
	Others			$I_{OL} = 24 \text{ mA}$				0.35	0.5	
I_{OZH}	RAS	$V_{CC} = \text{MAX},$ $V_O = 2.7 \text{ V}$	$V_{IH} = 2 \text{ V},$ $V_{IL} = \text{MAX},$			20		20	μA	
I_{OZL}	RAS	$V_{CC} = \text{MAX},$ $V_O = 0.4 \text{ V}$	$V_{IH} = 2 \text{ V},$ $V_{IL} = \text{MAX},$			-20		-20	μA	
I_I		$V_{CC} = \text{MAX},$	$V_I = 7 \text{ V}$			0.1		0.1	mA	
I_{IH}		$V_{CC} = \text{MAX},$	$V_I = 2.7 \text{ V}$			20		20	μA	
I_{IL}	REFRESH, R/W, RMW	$V_{CC} = \text{MAX},$	$V_I = 0.4 \text{ V}$			-0.4		-0.4	mA	
	Others					-0.2		-0.2		
I_O	ROW/COL	$V_{CC} = \text{MAX}$	$V_O = 2.25 \text{ V}$	-10	-50	-10	-50	mA		
	Others		$V_O = 0 \text{ V} §$	-30	-130	-30	-130			
I_{CC}		$V_{CC} = \text{MAX},$	Outputs open, All inputs at GND		38	65		38	65	mA

† For conditions shown as MIN or MAX, use the appropriate value specified under recommended operating conditions

‡ All typical values are at $V_{CC} = 5 \text{ V}, T_A = 25^\circ\text{C}$.

§ Not more than one output should be shorted at a time and the duration of the short-circuit should not exceed one second.

3

TTL DEVICES

TYPES SN54LS610 THRU SN54LS613, SN74LS610 THRU SN74LS613 MEMORY MAPPERS

D2549, JANUARY 1981 — REVISED DECEMBER 1983

- Expands 4 Address Lines to 12 Address Lines
- Designed for Paged Memory Mapping
- Output Latches Provided on 'LS610 and 'LS611
- Choice of 3-State or Open-Collector Map Outputs
- Compatible with TMS 9900 and Other Microprocessors

(TIM99610 THRU TIM99613)

SN54LS' ... JD PACKAGE
SN74LS' ... JD OR N PACKAGE
(TOP VIEW)

DEVICE	OUTPUTS LATCHED	MAP OUTPUT TYPE
'LS610	Yes	3-State
'LS611	Yes	Open-Collector
'LS612	No	3-State
'LS613	No	Open-Collector

description

These memory-mapper integrated circuits contain a 4-line to 16-line decoder, a 16-word by 12-bit RAM, 16 channels of 2-line to 1-line multiplexers, and other miscellaneous circuitry on a monolithic chip. The 'LS610 and 'LS611 also contain 12 latches with an enable control.

The memory mappers are designed to expand a microprocessor's memory address capability by eight bits. Four bits of the memory address bus (see the figure below) can be used to select one of 16 map registers that contain 12 bits each. These 12 bits are presented to the system memory address bus through the map output buffers along with the unused memory address bits from the CPU. However, addressable memory space without reloading the map registers is the same as would be available with the memory mapper left out. The addressable memory space is increased only by periodically reloading the map registers from the data bus.

This configuration lends itself to memory utilization of 16 pages of $2^{(n-4)}$ registers each without reloading (n = number of address bits available from CPU.)

These devices have four modes of operation (read, write, map, and pass). Data may be read from or loaded into the map register selected by the register select inputs (RS0 thru RS3) under control of R/W whenever chip select (CS) is low. The data I/O takes place on the data bus D0 thru D7. The map operation will output the contents of the map register selected by the map address inputs (MA0 thru MA3) when CS is high and MM (map mode control) is low. The 'LS612 and 'LS613 output stages are transparent in this mode, while the 'LS610 and 'LS611 outputs may be transparent or latched. When CS and MM are both high (pass mode), the address bits on MA0 thru MA3 appear at MO8-MO11, respectively, (assuming appropriate latch control) with low levels in the other bit positions on the map outputs.

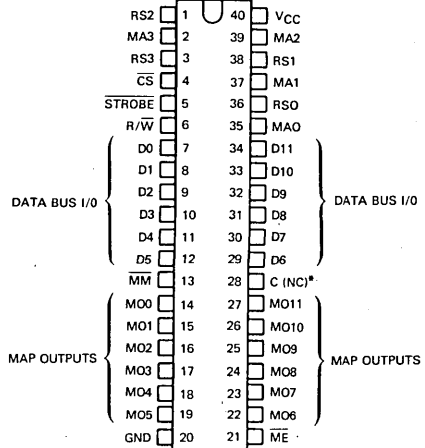

*Note: Pin 28 has no internal connection on 'LS612 and 'LS613
For chip carrier information, contact the factory.

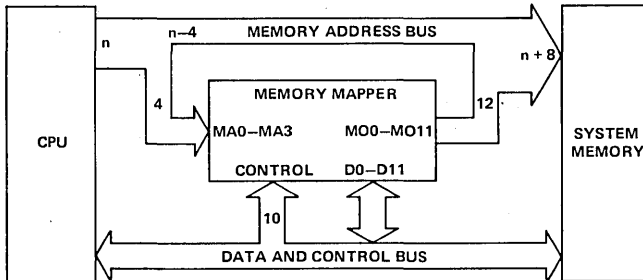

PRODUCTION DATA
This document contains information current as of publication date. Products conform to specifications per the terms of Texas Instruments standard warranty. Production processing does not necessarily include testing of all parameters.

TEXAS
INSTRUMENTS

POST OFFICE BOX 225012 • DALLAS, TEXAS 75265

3-1187

3

TTL DEVICES

TYPES SN54LS610 THRU SN54LS613, SN74LS610 THRU SN74LS613 MEMORY MAPPERS

functional block diagram (positive logic)

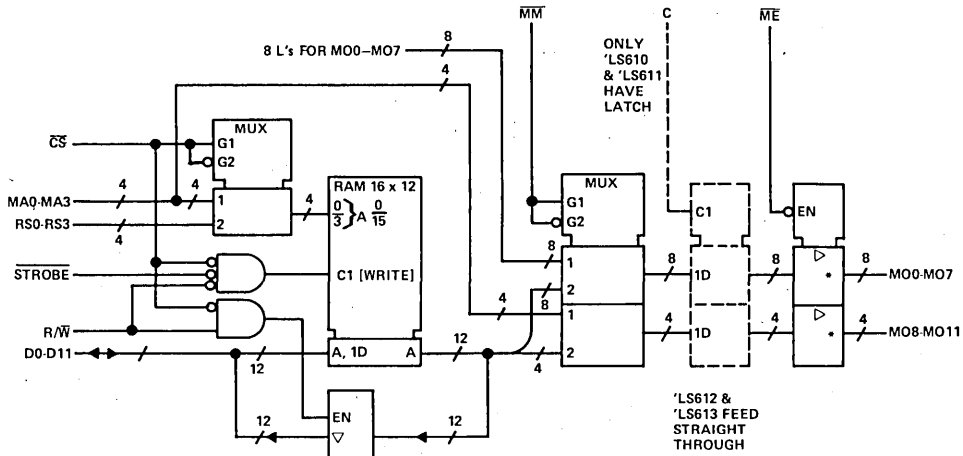

*'LS610 and 'LS612 have 3-state (∇) map outputs.
'LS611 and 'LS613 have open-collector (Ω) map outputs.

PIN FUNCTION TABLE

PIN	PIN NAME	FUNCTIONAL DESCRIPTION
7-12, 29-34	D0 thru D11	I/O connections to data and control bus used for reading from and writing to the map register selected by RS0-RS3 when \overline{CS} is low. Mode controlled by R/W.
36, 38, 1, 3	RS0 thru RS3	Register select inputs for I/O operations.
6	R/W	Read or write control used in I/O operations to select the condition of the data bus. When high, the data bus outputs are active for reading the map register. When low, the data bus is used to write into the register.
5	STROBE	Strobe input used to enter data into the selected map register during I/O operations.
4	\overline{CS}	Chip select input. A low input level selects the memory mapper (assuming more than one used) for an I/O operation.
35, 37, 39, 2	MA0 thru MA3	Map address inputs to select one of 16 map registers when in map mode (MM low and \overline{CS} high).
14-19, 22-27	MO0 thru MO11	Map outputs. Present the map register contents to the system memory address bus in the map mode. In the pass mode, these outputs provide the map address data on MO8-MO11 and low levels on MO0-MO7.
13	MM	Map mode input. When low, 12 bits of data are transferred from the selected map register to the map outputs. When high (pass mode), the 4 bits present on the map address inputs MA0-MA3 are passed to the map outputs MO8-MO11, respectively, while MO0-MO7 are set low.
21	\overline{ME}	Map enable for the map outputs. A low level allows the outputs to be active while a high input level puts the outputs at high impedance.
28	C	Latch enable input for the 'LS610 and 'LS611 (no internal connection for 'LS612 and 'LS613). A high level will transparently pass data to the map outputs. A low level will latch the outputs.
40, 20	V _{CC} , GND	5-V power supply and network ground (substrate) pins.

3

TTL DEVICES

TYPES SN54LS610 THRU SN54LS613, SN74LS610 THRU SN74LS613 MEMORY MAPPERS

schematics of inputs and outputs

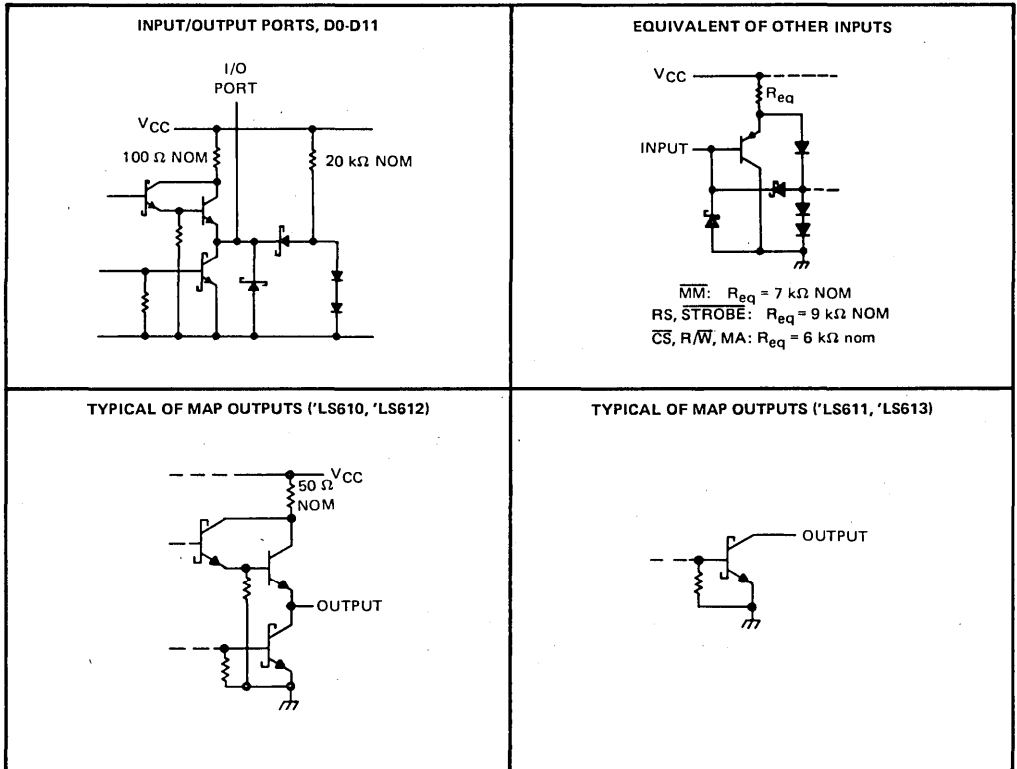

absolute maximum ratings over operating free-air temperature range (unless otherwise noted)

Supply voltage, V_{CC} (see Note 1)	7 V
Input voltage: Data Bus I/O	5.5 V
All other inputs	7 V
Operating free-air temperature range: SN54LS610 through SN54LS613	-55°C to 125°C
SN74LS610 through SN74LS613	0°C to 70°C
Storage temperature range	-65°C to 150°C

NOTE 1: Voltage values are with respect to network ground terminal.

TYPES SN54LS610, SN54LS612, SN74LS610, SN74LS612 MEMORY MAPPERS WITH 3-STATE MAP OUTPUTS

recommended operating conditions

			SN54LS610 SN54LS612			SN74LS610 SN74LS612			UNIT
			MIN	NOM	MAX	MIN	NOM	MAX	
V _{CC}	Supply voltage		4.5	5	5.5	4.75	5	5.25	V
I _{OH}	High-level output current	MO	-12			-15			mA
		D	-1			-2.6			
I _{OL}	Low-level output current	MO	12			24			mA
		D	4			8			
t _{AVCL}	C setup time (AV before C low)	'LS610 only	See Figure 2			30			ns
t _{SLSH}	Width of strobe input pulse		75			75			ns
t _{CSSL}	CS setup (CS low to strobe low)		20			20			ns
t _{WL}	R/W setup time (R/W low to strobe low)		20			20			ns
t _{RVSL}	RS setup time (RS valid to strobe low)		20			20			ns
t _{DVSH}	Data setup time (D0-D11 valid to strobe high)		75			75			ns
t _{SHCSH}	CS hold time (Strobe high to CS high)		20			20			ns
t _{SHWH}	R/W hold time (Strobe high to R/W high)		20			20			ns
t _{SHRX}	RS hold time (Strobe high to RS invalid)		20			20			ns
t _{SHDX}	Data hold time (Strobe high to D0-D11 invalid)		20			20			ns
T _A	Operating free-air temperature		-55		125	0		70	°C

electrical characteristics over recommended operating free-air temperature range (unless otherwise noted)

PARAMETER		TEST CONDITIONS†	SN54LS610 SN54LS612			SN74LS610 SN74LS612			UNIT	
			MIN	TYP‡	MAX	MIN	TYP‡	MAX		
V _{IH}	High-level input voltage		2			2			V	
V _{IL}	Low-level input voltage		0.7			0.8			V	
V _{IK}	Input clamp voltage	V _{CC} = MIN, I _I = -18 mA	-1.5			-1.5			V	
V _{OH}	High-level output voltage	MO V _{CC} = MIN, V _{IH} = 2 V, V _{IL} = V _{IL} max	I _{OH} = -3 mA	2.4		2.4		V		
			I _{OH} = MAX	2		2				
V _{OL}	Low-level output voltage	MO V _{CC} = MIN, V _{IH} = 2 V, V _{IL} = V _{IL} max	I _{OL} = 12 mA	0.25	0.4	0.25	0.4	V		
			I _{OL} = 24 mA			0.35 0.5				
			I _{OL} = 4 mA	0.25 0.4		0.25 0.4				
			I _{OL} = 8 mA			0.35 0.5				
I _{OZH}	Off-state output current, high-level voltage applied	V _{CC} = MAX, V _{IH} = 2 V, V _{IL} = V _{IL} max, V _O = 2.7 V	20			20			µA	
I _{OZL}	Off-state output current, low-level voltage applied	MO V _{CC} = MAX, V _{IH} = 2 V, V _{IL} = V _{IL} max, V _O = 0.4 V	-20			-20			µA	
			-400			-400				
I _I	Input current at maximum input voltage	D	V _I = 5.5 V		100		100		µA	
		All others	V _I = 7 V		100		100			
I _{IH}	High-level input current	V _{CC} = MAX, V _I = 2.7 V	20			20			µA	
I _{IL}	Low-level input current	V _{CC} = MAX, V _I = 0.4 V	-0.4			-0.4			mA	
I _{OS}	Short-circuit output current §	MO V _{CC} = MAX	-40		-225		-40		-225	
			-30		-130		-30		-130	
I _{CC}	Supply current	V _{CC} = MAX	Outputs high		112 180		112 180		mA	
			Outputs low		112 180		112 180			
			Outputs at high impedance		150 230		180 230			

† For conditions shown as MIN or MAX, use the appropriate value specified under recommended operating conditions.

‡ All typical values are at V_{CC} = 5 V, T_A = 25°C.

§ Not more than one output should be shorted at a time, and duration of the short-circuit should not exceed one second.

TYPES SN54LS610, SN54LS612, SN74LS610, SN74LS612 MEMORY MAPPERS WITH 3-STATE MAP OUTPUTS

switching characteristics, $V_{CC} = 5\text{ V}$, $T_A = 25^\circ\text{C}$, $C_L = 45\text{ pF}$ to GND

PARAMETER	FROM (INPUT)	TO (OUTPUT)	TEST CONDITIONS	'LS610			'LS612			UNIT
				MIN	TYP	MAX	MIN	TYP	MAX	
t _{CSLDV} Access (enable) time	CS↓	D 0-11	R _L = 2 kΩ See Figure 1, See Notes 3 and 4	28	50		26	50	ns	
t _{WHDV} Access (enable) time	R/W↑	D 0-11		20	35		20	35	ns	
t _{RVVDV} Access time	RS	D 0-11		49	75		39	75	ns	
t _{WLZ} Disable time	R/W↓	D 0-11		32	50		30	50	ns	
t _{CSDZ} Disable time	CS↑	D 0-11	42	65		38	65	ns		
t _{ELQV} Access (enable) time	ME↓	MO 0-11	R _L = 667 Ω, See Figure 2, See Notes 3 and 4	19	30		17	30	ns	
t _{CSHOV} Access time	CS↑	MO 0-11		56	85		48	85	ns	
t _{MLQV} Access time	MM↓	MO 0-11		25	40		22	40	ns	
t _{CHOV} Access time	C↑	MO 0-11		24	40				ns	
t _{AVQV1} Access time (MM low)	MA	MO 0-11		46	70		39	70	ns	
t _{MHOV} Access time	MM↑	MO 0-11		24	40		22	40	ns	
t _{AVQV2} Propagation time (MM high)	MA	MO 8-11		19	30		13	30	ns	
t _{EHQZ} Disable time	ME↑	MO 0-11		14	25		14	25	ns	

NOTE: 3. Access times are tested as t_{PLH} and t_{PHL} or t_{PZH} or t_{PZL}. Disable times are tested as t_{PHZ} and t_{PLZ}.
4. See General Information Section for load circuits and voltage waveforms.

explanation of letter symbols

This data sheet uses a new type of letter symbol to describe time intervals. The format is:

t_{AB-CD}

where: subscripts A and C indicate the names of the signals for which changes of state or level or establishment of state or level constitute signal events assumed to occur first and last, respectively, that is, at the beginning and end of the time interval.

Subscripts B and D indicate the direction of the transitions and/or the final states or levels of the signals represented by A and C, respectively. One or two of the following is used:

- H = high or transition to high
- L = low or transition to low
- V = a valid steady-state level
- X = unknown, changing, or "don't care" level
- Z = high-impedance (off) state.

The hyphen between the B and C subscripts is omitted when no confusion is likely to occur. For these letter symbols on this data sheet, the signal names are further abbreviated as follows:

SIGNAL NAME	A AND C- SUBSCRIPT
C	C
CS	CS
D0-11	D
MA0-MA3	A
MO0-MO11	Q
ME	E
MM	M
R/W	W
RS0-RS3	R
STROBE	S

TYPES SN54LS611, SN54LS613, SN74LS611, SN74LS613 MEMORY MAPPERS WITH OPEN-COLLECTOR MAP OUTPUTS

recommended operating conditions

			SN54LS611 SN54LS613			SN74LS611 SN74LS613			UNIT		
			MIN	NOM	MAX	MIN	NOM	MAX			
V _{CC}	Supply voltage		4.5	5	5.5	4.75	5	5.25	V		
V _{OH}	High-level output voltage		MO			5.5			V		
I _{OH}	High-level output current		D			-1			-2.6	mA	
I _{OL}	Low-level output current		MO			12			24	mA	
			D			4			8		
t _{AVCL}	C setup time (AV before C low)	'LS611 only	See Figure 2			30			ns		
t _{SLSH}	Width of strobe input pulse		75			75			ns		
t _{CSSL}	CS setup time (CS low to strobe low)		20			20			ns		
t _{WLSL}	R/W setup time (R/W low to strobe low)		20			20			ns		
t _{RVSL}	RS setup time (RS valid to strobe low)		20			20			ns		
t _{DVSH}	Data setup time (D0-D11 valid to strobe high)		75			75			ns		
t _{SHCSH}	CS hold time (Strobe high to CS high)		20			20			ns		
t _{SHWH}	R/W hold time (Strobe high to R/W high)		20			20			ns		
t _{SHRX}	RS hold time (Strobe high to RS invalid)		20			20			ns		
t _{SHDX}	Data hold time (Strobe high to D0-D11 invalid)		20			20			ns		
T _A	Operating free-air temperature		-55			125			0	70	°C

NOTE 2: Voltage values are with respect to network ground terminal.

electrical characteristics over recommended operating free-air temperature range (unless otherwise noted)

PARAMETER		TEST CONDITIONS†		SN54LS611 SN54LS613		SN74LS611 SN74LS613		UNIT	
				MIN	TYP‡	MAX	MIN		TYP‡
V _{IH}	High-level input voltage			2		2		V	
V _{IL}	Low-level input voltage			0.7		0.8		V	
V _{IK}	Input clamp voltage	V _{CC} = MIN, I _I = -18 mA		-1.5		-1.5		V	
V _{OH}	High-level output voltage	D	V _{CC} = MIN, V _{IH} = 2 V, V _{IL} = V _{IL} max, I _{OH} = MAX	2.4		2.4			
I _{OH}	High-level output current	MO	V _{CC} = MIN, V _{IH} = 2 V, V _{OH} = 5.5 V	100		100		μA	
V _{OL}	Low-level output voltage	MO	V _{CC} = MIN, V _{IH} = 2 V, V _{IL} = V _{IL} max	I _{OL} = 12 mA	0.25	0.4	0.25	0.4	V
				I _{OL} = 24 mA			0.35	0.5	
		D	V _{CC} = MIN, V _{IH} = 2 V, V _{IL} = V _{IL} max	I _{OL} = 4 mA	0.25	0.4	0.25	0.4	
				I _{OL} = 8 mA			0.35	0.5	
I _{OZH}	Off-state output current, high-level voltage applied	D	V _{CC} = MAX, V _{IH} = 2 V, V _{IL} = V _{IL} max, V _O = 2.7 V	20		20			
I _{OZL}	Off-state output current, low-level voltage applied	D	V _{CC} = MAX, V _{IH} = 2 V, V _O = 0.4 V	-400		-400		μA	
I _I	Input current at maximum input voltage	D	V _{CC} = MAX	V _I = 5.5 V		100		100	
		All others	V _{CC} = MAX	V _I = 7 V		100		100	
I _{IH}	High-level input current	V _{CC} = MAX, V _I = 2.7 V		20		20			
I _{IL}	Low-level input current	V _{CC} = MAX, V _I = 0.4 V		-0.4		-0.4		mA	
I _{OS}	Short-circuit output current§	D	V _{CC} = MAX	-30	-130	-30	-130	mA	
I _{CC}	Supply current	V _{CC} = MAX		Outputs high	100	170	100	170	mA
				Outputs low	100	170	100	170	
				Outputs at high impedance	110	200	110	200	

†For conditions shown as MIN or MAX, use the appropriate value specified under recommended operating conditions.

‡All typical values are at V_{CC} = 5 V, T_A = 25°C.

§Not more than one output should be shorted at a time, and duration of the short-circuit should not exceed one second.

TYPES SN54LS611, SN54LS613, SN74LS611, SN74LS613 MEMORY MAPPERS WITH OPEN-COLLECTORS OUTPUTS

switching characteristics, $V_{CC} = 5\text{ V}$, $T_A = 25^\circ\text{C}$, $C_L = 45\text{ pF}$ to GND

PARAMETER	FROM (INPUT)	TO (OUTPUT)	TEST CONDITIONS	'LS611			'LS613			UNIT
				MIN	TYP	MAX	MIN	TYP	MAX	
t_{CSLDV} Access (enable) time	$\overline{CS}\downarrow$	D 0-11	$R_L = 2\text{ k}\Omega$, See Figure 1, See Notes 3 and 4	31	50		28	50	ns	
t_{WHDV} Access (enable) time	$R/\overline{W}\uparrow$	D 0-11		23	35		21	35	ns	
t_{RVDV} Access time	RS	D 0-11		51	75		47	75	ns	
t_{WLDZ} Disable time	$R/\overline{W}\downarrow$	D 0-11		32	50		31	50	ns	
t_{CSHDZ} Disable time	$\overline{CS}\uparrow$	D 0-11	$R_L = 667\ \Omega$, See Figure 2, See Notes 3 and 4	41	65		40	65	ns	
t_{ELQV} Access (enable) time	$\overline{ME}\downarrow$	MO 0-11		21	30		19	30	ns	
t_{CSHQV} Access time	$\overline{CS}\uparrow$	MO 0-11		57	90		53	90	ns	
t_{MLQV} Access time	MM \downarrow	MO 0-11		25	40		25	40	ns	
t_{CHQV} Access time	C \uparrow	MO 0-11		30	45				ns	
t_{AVQV1} Access time (MM low)	MA	MO 0-11		47	70		44	70	ns	
t_{MHQV} Access time	MM \uparrow	MO 0-11		31	50		31	50	ns	
t_{AVQV2} Propagation time (MM high)	MA	MO 8-11		21	30		20	30	ns	
t_{EHQZ} Disable time	$\overline{ME}\uparrow$	MO 0-11		15	25		15	25	ns	

NOTE: 3. Access times are tested as t_{PLH} and t_{PHL} or t_{PZH} or t_{PZL} . Disable times are tested as t_{PHZ} and t_{PLZ} .
4. See General Information Section for load circuits and voltage waveforms.

TIMING DIAGRAMS

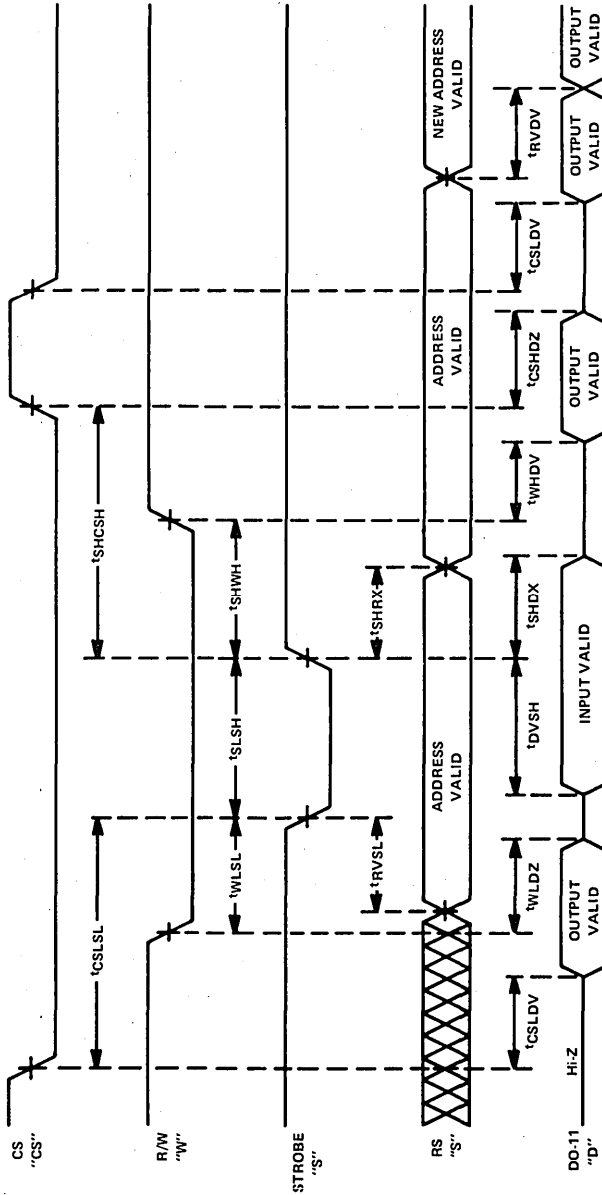

FIGURE 1—WRITE AND READ MODES

TYPES SN54LS610 THRU SN54LS613, SN74LS610 THRU SN74LS613
MEMORY MAPPERS WITH OPEN-COLLECTOR OUTPUTS

TIMING DIAGRAMS

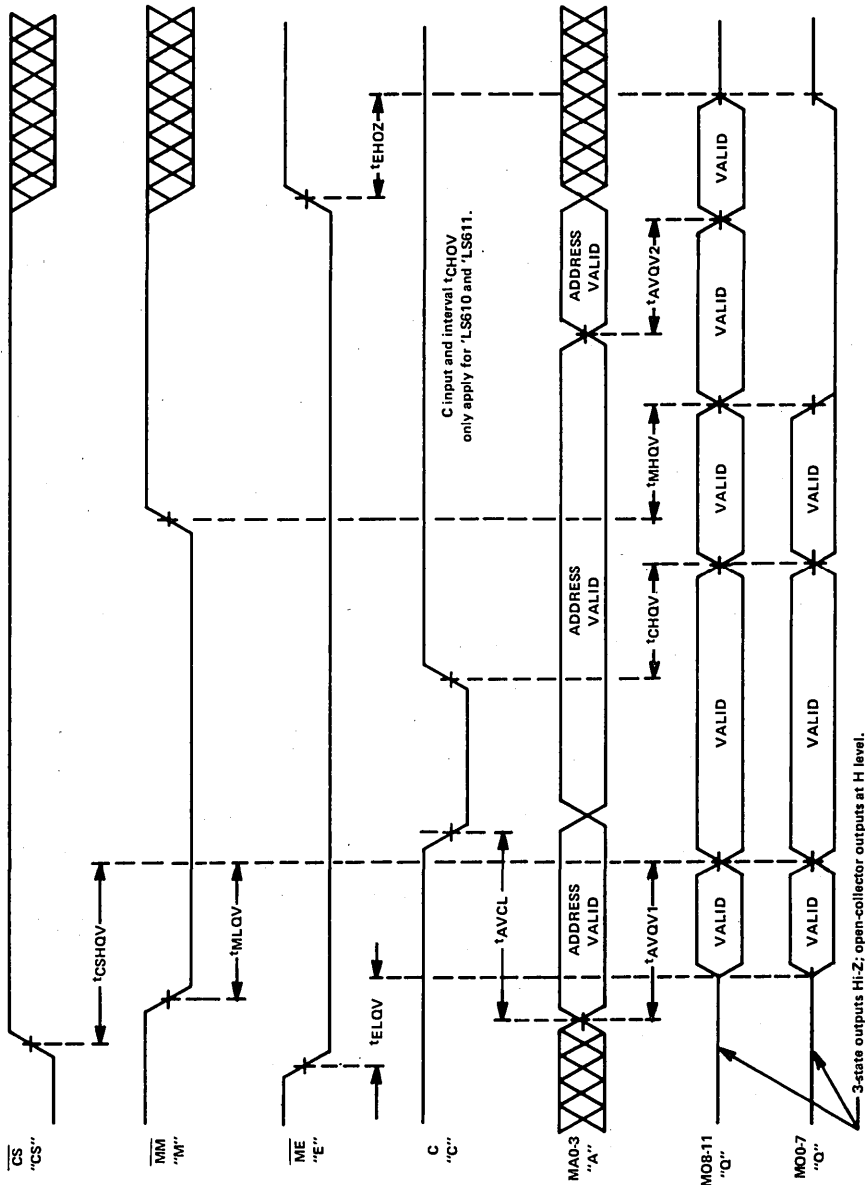

FIGURE 2—MAP AND PASS MODES



TTL DEVICES

TYPES SN54LS620 THRU SN54LS623, SN74LS620 THRU SN74LS623 OCTAL BUS TRANSCEIVERS

D2537, AUGUST 1979 — REVISED DECEMBER 1983

- Bidirectional Bus Transceivers in High-Density 20-Pin Packages
- Local Bus-Latch Capability
- Hysteresis at Bus Inputs Improves Noise Margins
- Choice of True or Inverting Logic
- Choice of 3-State or Open-Collector Outputs

DEVICE	OUTPUT	LOGIC
'LS620	3-State	Inverting
'LS621	Open-Collector	True
'LS622	Open-Collector	Inverting
'LS623	3-State	True

description

These octal bus transceivers are designed for asynchronous two-way communication between data buses. The control function implementation allows for maximum flexibility in timing.

These devices allow data transmission from the A bus to the B bus or from the B bus to the A bus depending upon the logic levels at the enable inputs ($\overline{\text{GBA}}$ and $\overline{\text{GAB}}$).

The enable inputs can be used to disable the device so that the buses are effectively isolated.

The dual-enable configuration gives the 'LS620 thru 'LS623 the capability to store data by simultaneous enabling of $\overline{\text{GBA}}$ and $\overline{\text{GAB}}$. Each output reinforces its input in this transceiver configuration. Thus, when both control inputs are enabled and all other data sources to the two sets of bus lines are at high impedance, both sets of bus lines (16 in all) will remain at their last states. The 8-bit codes appearing on the two sets of buses will be identical for the 'LS621 and 'LS623 devices or complementary for the 'LS620 and 'LS622.

SN54LS620, SN54LS621, SN54LS622
SN54LS623 ... J PACKAGE
SN74LS620, SN74LS621, SN74LS622
SN74LS623 ... DW, J OR N PACKAGE

(TOP VIEW)

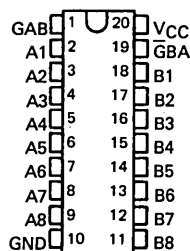

SN54LS620, SN54LS621, SN54LS622
SN54LS623 ... FK PACKAGE
SN74LS620, SN74LS621, SN74LS622
SN74LS623 ... FN PACKAGE

(TOP VIEW)

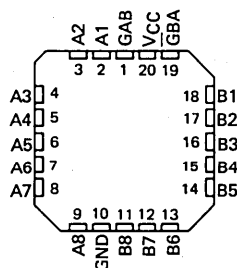

FUNCTION TABLE

ENABLE INPUTS		OPERATION	
$\overline{\text{GBA}}$	$\overline{\text{GAB}}$	'LS620, 'LS622	'LS621, 'LS623
L	L	$\overline{\text{B}}$ data to A bus	B data to A bus
H	H	A data to B bus	A data to B bus
H	L	Isolation	Isolation
L	H	$\overline{\text{B}}$ data to A bus, $\overline{\text{A}}$ data to B bus	B data to A bus, A data to B bus

H = high level, L = low level

absolute maximum ratings over operating free-air temperature range (unless otherwise noted)

Supply voltage, V_{CC} (see Note 1)	7 V
Input voltage	7 V
Off-state output voltage	5.5 V
Operating free-air temperature range: SN54LS'	-55°C to 125°C
SN74LS'	0°C to 70°C
Storage temperature range	-65°C to 150°C

NOTE 1: Voltage values are with respect to network ground terminal.

PRODUCTION DATA
This document contains information current as of publication date. Products conform to specifications per the terms of Texas Instruments standard warranty. Production processing does not necessarily include testing of all parameters.

**TEXAS
INSTRUMENTS**

POST OFFICE BOX 225012 • DALLAS, TEXAS 75265

3-1197

3

TTL DEVICES

TYPES SN54LS620 THRU SN54LS623, SN74LS620 THRU SN74LS623 OCTAL BUS TRANSCEIVERS

logic symbols

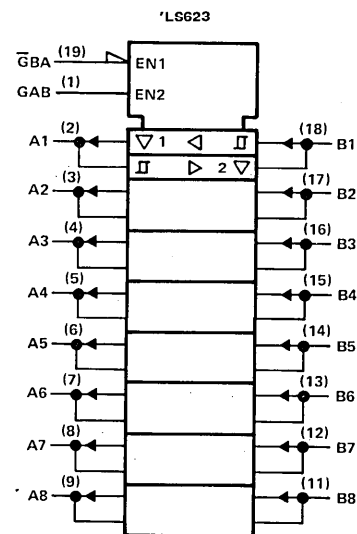
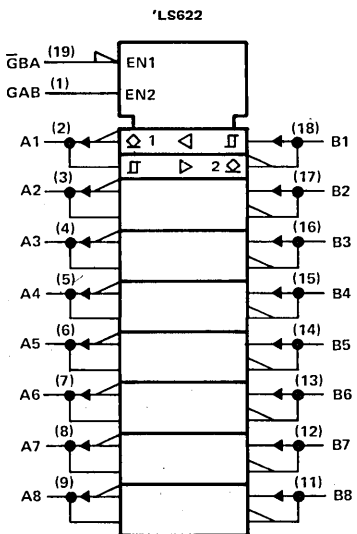
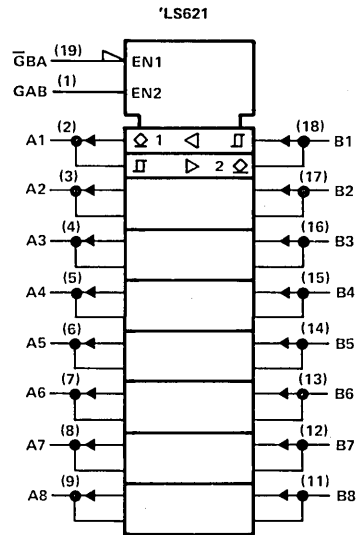
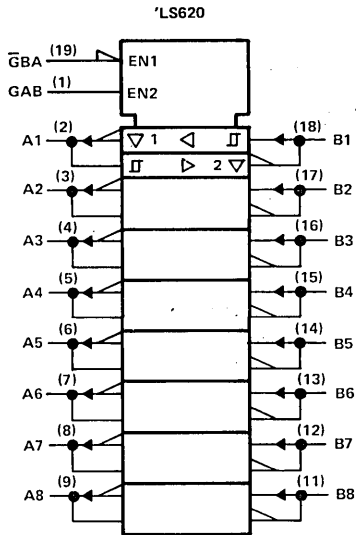

Pin numbers shown on logic notation are for DW, J or N packages.

3

TTL DEVICES

TYPES SN54LS620 THRU SN54LS623,
SN74LS620 THRU SN74LS623
OCTAL BUS TRANSCEIVERS

logic diagrams (positive logic)

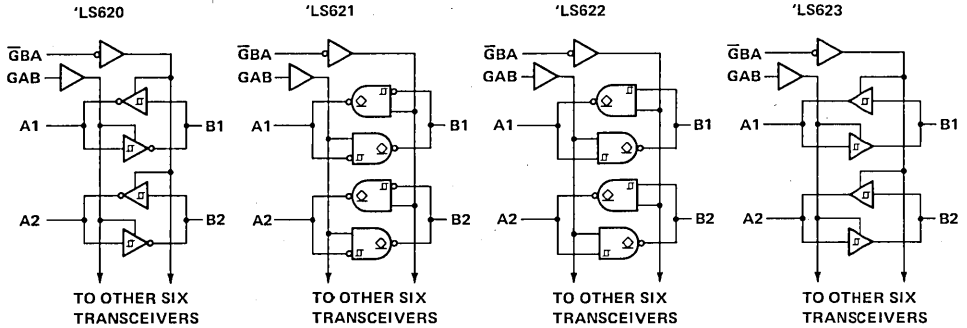

schematics of inputs and outputs

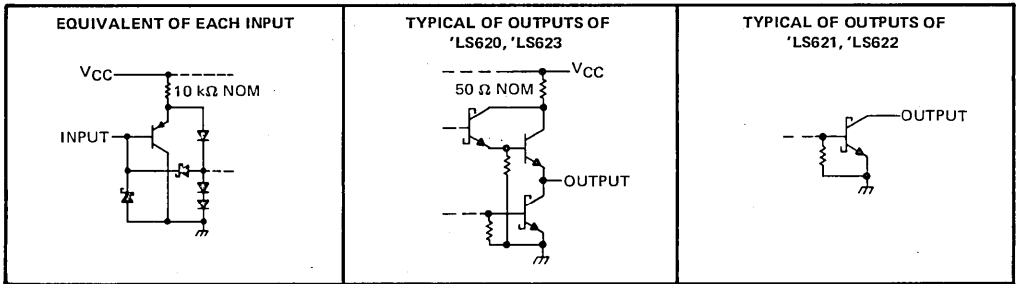

TTL DEVICES

TYPES SN54LS620, SN54LS623, SN74LS620, SN74LS623 OCTAL BUS TRANSCEIVERS WITH 3-STATE OUTPUTS

recommended operating conditions

PARAMETER	SN54LS620 SN54LS623			SN74LS620 SN74LS623			UNIT
	MIN	NOM	MAX	MIN	NOM	MAX	
Supply voltage, V_{CC} (see Note 1)	4.5	5	5.5	4.75	5	5.25	V
High-level output current, I_{OH}				-12			-15 mA
Low-level output current, I_{OL}				12			24 mA
Operating free-air temperature, T_A	-55			125			0 70 °C

NOTE 1: Voltage values are with respect to network ground terminal.

electrical characteristics over recommended operating free-air temperature range (unless otherwise noted)

PARAMETER		TEST CONDITIONS†	SN54LS620 SN54LS623			SN74LS620 SN74LS623			UNIT
			MIN	TYP‡	MAX	MIN	TYP‡	MAX	
V_{IH}	High-level input voltage		2			2			V
V_{IL}	Low-level input voltage					0.5			V
V_{IK}	Input clamp voltage	$V_{CC} = \text{MIN}, I_I = -18 \text{ mA}$				-1.5			V
	Hysteresis ($V_{T+} - V_{T-}$) A or B input	$V_{CC} = \text{MIN}$	0.1	0.4		0.2	0.4	V	
V_{OH}	High-level output voltage	$V_{CC} = \text{MIN}, V_{IH} = 2 \text{ V}, V_{IL} = V_{IL \text{ max}}$	$I_{OH} = -3 \text{ mA}$ 2.4 3.4			$I_{OH} = \text{MAX}$ 2 3.4		V	
V_{OL}	Low-level output voltage	$V_{CC} = \text{MIN}, V_{IH} = 2 \text{ V}, V_{IL} = V_{IL \text{ max}}$	$I_{OL} = 12 \text{ mA}$ 0.25 0.4			$I_{OL} = 24 \text{ mA}$ 0.25 0.4		V	
I_{OZH}	Off-state output current, high-level voltage applied	$V_{CC} = \text{MAX}, V_O = 2.7 \text{ V}, \bar{G}$ at 2 V,				20			μA
I_{OZL}	Off-state output current, low-level voltage applied	$V_{CC} = \text{MAX}, V_O = 0.4 \text{ V}, \bar{G}$ at 2 V,				-400			μA
I_I	Input current at maximum input voltage	A or B GBA or GAB	$V_{CC} = \text{MAX}, V_I = 5.5 \text{ V}$ 0.1			$V_I = 7 \text{ V}$ 0.1		0.1 mA	
I_{IH}	High-level input current	$V_{CC} = \text{MAX}, V_I = 2.7 \text{ V}$				20			μA
I_{IL}	Low-level input current	$V_{CC} = \text{MAX}, V_I = 0.4 \text{ V}$				-0.4			μA
I_{OS}	Short-circuit output current §	$V_{CC} = \text{MAX}$	-40	-225		-40	-225	mA	
I_{CC}	Total supply current	$V_{CC} = \text{MAX},$ Outputs high Outputs low Outputs at Hi-Z	48	70		48	70	mA	
			62	90		62	90		
			64	95		64	95		

† For conditions shown as MIN or MAX use the appropriate value specified under recommended operating conditions.

‡ All typical values are at $V_{CC} = 5 \text{ V}, T_A = 25^\circ\text{C}$.

§ Not more than one output should be shorted at a time, and duration of the short-circuit should not exceed one second.

switching characteristics at $V_{CC} = 5 \text{ V}, T_A = 25^\circ\text{C}$

PARAMETER	FROM (INPUT)	TO (OUTPUT)	TEST CONDITIONS	'LS620			'LS623			UNIT
				MIN	TYP	MAX	MIN	TYP	MAX	
t_{PLH}	A	B	$C_L = 45 \text{ pF}, R_L = 667 \Omega,$	6	10		8	15	ns	
	B	A		6	10		8	15		
t_{PHL}	A	B	$C_L = 45 \text{ pF}, R_L = 667 \Omega,$	8	15		11	15	ns	
	B	A		8	15		11	15		
t_{pZL}	$\bar{G}BA$	A	See Note 2	31	40		31	40	ns	
	GAB	B		31	40		31	40		
t_{pZH}	$\bar{G}BA$	A	See Note 2	23	40		26	40	ns	
	GAB	B		23	40		26	40		
t_{pLZ}	$\bar{G}BA$	A	$C_L = 5 \text{ pF}, R_L = 667 \Omega,$	15	25		15	25	ns	
	GAB	B		15	25		15	25		
t_{pHZ}	$\bar{G}BA$	A	See Note 2	15	25		15	25	ns	
	GAB	B		15	25		15	25		

t_{PLH} = Propagation delay time, low-to-high-level output

t_{PHL} = Propagation delay time, high-to-low-level output

t_{pZH} = Output enable time to high level

NOTE 2: See General Information Section for load circuits and voltage waveforms.

t_{pZL} = Output enable time to low level

t_{pHZ} = Output disable time from high level

t_{pLZ} = Output disable time from low level

TYPES SN54LS621, SN54LS622, SN74LS621, SN74LS622 OCTAL BUS TRANSCEIVERS WITH OPEN-COLLECTOR OUTPUTS

recommended operating conditions

PARAMETER	SN54LS621 SN54LS622			SN74LS621 SN74LS622			UNIT	
	MIN	NOM	MAX	MIN	NOM	MAX		
Supply voltage, V_{CC} (see Note 1)	4.5	5	5.5	4.75	5	5.25	V	
High-level output voltage, V_{OH}	5.5			5.5			V	
Low-level output current, I_{OL}	12			24			mA	
Operating free-air temperature, T_A	-55			0			70	°C

NOTE 1: Voltage values are with respect to network ground terminal.

electrical characteristics over recommended operating free-air temperature range (unless otherwise noted)

PARAMETER	TEST CONDITIONS†	SN54LS621 SN54LS622			SN74LS621 SN74LS622			UNIT
		MIN	TYP‡	MAX	MIN	TYP‡	MAX	
V_{IH} High-level input voltage		2			2			V
V_{IL} Low-level input voltage		0.5			0.6			V
V_{IK} Input clamp voltage	$V_{CC} = \text{MIN}, I_I = -18 \text{ mA}$	-1.5			-1.5			V
Hysteresis ($V_{T+} - V_{T-}$) A or B input	$V_{CC} = \text{MIN}$	0.1	0.4		0.2	0.4	V	
I_{OH} High-level output current	$V_{CC} = \text{MIN}, V_{IH} = 2 \text{ V}, V_{IL} = V_{IL \text{ max}}, V_{OH} = 5.5 \text{ V}$	100			100			µA
V_{OL} Low-level output voltage	$V_{CC} = \text{MIN}, V_{IH} = 2 \text{ V}, V_{IL} = V_{IL \text{ max}}$	$I_{OL} = 12 \text{ mA}$ $I_{OL} = 24 \text{ mA}$			$I_{OL} = 12 \text{ mA}$ $I_{OL} = 24 \text{ mA}$			V
I_I Input current at maximum input voltage	$V_{CC} = \text{MAX}, V_I = 7 \text{ V}$	0.1			0.1			mA
I_{IH} High-level input current	$V_{CC} = \text{MAX}, V_I = 2.7 \text{ V}$	20			20			µA
I_{IL} Low-level input current	$V_{CC} = \text{MAX}, V_I = 0.4 \text{ V}$	-0.4			-0.4			mA
I_{CC} Total supply current	Outputs high	48 70			48 70			mA
	Outputs low	62 90			62 90			

†For conditions shown as MIN or MAX use the appropriate value specified under recommended operating conditions.

‡All typical values are at $V_{CC} = 5 \text{ V}, T_A = 25^\circ\text{C}$.

switching characteristics at $V_{CC} = 5 \text{ V}, T_A = 25^\circ\text{C}$

PARAMETER	FROM (INPUT)	TO (OUTPUT)	TEST CONDITIONS	'LS621			'LS622			UNIT
				MIN	TYP	MAX	MIN	TYP	MAX	
t_{PLH} Propagation delay time, low-to-high-level output	A	B	$C_L = 45 \text{ pF},$	17 25			19 25			ns
	B	A		17 25			19 25			
t_{PHL} Propagation delay time, high-to-low-level output	A	B	$R_L = 667 \Omega,$	16 25			14 25			ns
	B	A		16 25			14 25			
t_{PLH} Output disable time from low level	GBA	A	See Note 2	23 40			26 40			ns
	GAB	B		25 40			28 40			
t_{PHL} Output enable time from high level	GBA	A	See Note 2	34 50			43 60			ns
	GAB	B		37 50			39 60			

t_{PLH} = Propagation delay time, low-to-high-level input.

t_{PHL} = Propagation delay time, high-to-low-level input.

NOTE 2: See General Information Section for load circuits and voltage waveforms.

TTL DEVICES

**TYPES SN54LS624 THRU SN54LS629,
SN74LS624 THRU SN74LS629
VOLTAGE-CONTROLLED OSCILLATORS**

D2501, JANUARY 1980 — REVISED DECEMBER 1983

- Separate Supply Voltage Pins for Isolation of Frequency Control Inputs and Oscillators from Output Circuitry
- Highly Stable Operation over Specified Temperature and/or Supply Voltage Ranges

DEVICE TYPE	SIMILAR TO	NUMBER VCO's	COMP'L Z OUT	ENABLE	RANGE INPUT	R _{ext}
'LS624	'LS324	single	yes	yes	yes	no
'LS625	'LS325	dual	yes	no	no	no
'LS626	'LS326	dual	yes	yes	no	no
'LS627	'LS327	dual	no	no	no	no
'LS628	'LS324	single	yes	yes	yes	yes
'LS629	'LS124	dual	no	yes	yes	no

description

These voltage-controlled oscillators (VCO's) are improved versions of the original VCO family: SN54LS124, SN54LS324 thru SN54LS327, SN74LS124, and SN74LS324 thru SN74LS327. These new devices feature improved voltage-to-frequency linearity, range, and compensation. With the exception of the 'LS624 and 'LS628, all of these devices feature two independent VCO's in a single monolithic chip. The 'LS624, 'LS625, 'LS626 and 'LS628 have complementary Z outputs. The output frequency for each VCO is established by a single external capacitor in combination with voltage-sensitive inputs used for frequency control and frequency range. Each device has a voltage-sensitive input for frequency control; however, the 'LS624, 'LS628, and 'LS629 devices also have one for frequency range. (See Figures 1 thru 6).

The 'LS628 offers more precise temperature compensation than its 'LS624 counterpart. The 'LS624 features a 600 ohm internal timing resistor. The 'LS628 requires a timing resistor to be connected externally across R_{ext} pins. Temperature compensation will be improved due to the temperature coefficient of the external resistor.

Figure 3 and Figure 6 contain the necessary information to choose the proper capacitor value to obtain the desired operating frequency.

A single 5-volt supply can be used: however, one set of supply voltage and ground pins (V_{CC} and GND) is provided for the enable, synchronization-gating, and output sections, and a separate set (OSC V_{CC} and OSC GND) is provided for the oscillator and associated frequency-control circuits so that effective isolation can be accomplished in the system. For operation of frequencies greater than 10 MHz, it is recommended that two independent supplies be used. Disabling either VCO of the 'LS625 and 'LS625 and 'LS627 can be achieved by removing the appropriate OSC V_{CC}. An enable input is provided on the 'LS624, 'LS626, 'LS628, and 'LS629. When the enable input is low, the output is enabled: when the enable input is high, the internal oscillator is disabled, Y is high, and Z is low. Caution! Crosstalk may occur in the dual devices ('LS625, 'LS626, 'LS627 and 'LS629) when both VCO's are operated simultaneously.

The pulse-synchronization-gating section ensures that the first output pulse is neither clipped nor extended. The duty cycle of the square-wave output is fixed at approximately 50 percent.

The SN54LS624 thru SN54LS629 are characterized for operation over the full military temperature range of -55°C to 125°C. The SN74LS624 thru SN74LS629 are characterized for operation from 0°C to 70°C.



TTL DEVICES

PRODUCTION DATA

This document contains information current as of publication date. Products conform to specifications per the terms of Texas Instruments standard warranty. Production processing does not necessarily include testing of all parameters.



POST OFFICE BOX 225012 • DALLAS, TEXAS 75265

TYPES SN54LS624 THRU SN54LS629, SN74LS624 THRU SN74LS629 VOLTAGE-CONTROLLED OSCILLATORS

SN54LS624 ... J OR W PACKAGE
SN74LS624 ... D, J OR W PACKAGE
(TOP VIEW)

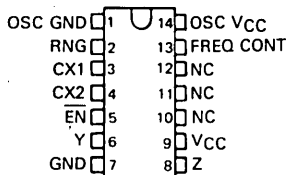

SN54LS625 ... J OR W PACKAGE
SN74LS625 ... D, J OR N PACKAGE
(TOP VIEW)

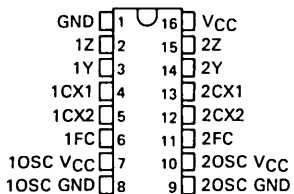

SN54LS626 ... J OR W PACKAGE
SN74LS626 ... D, J OR N PACKAGE
(TOP VIEW)

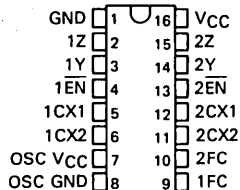

NC - No internal connection

SN54LS624 ... FK PACKAGE
SN74LS624 ... FN PACKAGE
(TOP VIEW)

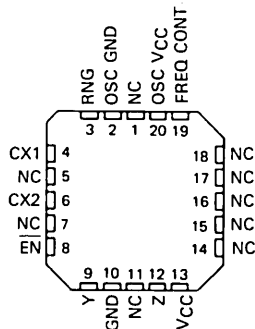

SN54LS625 ... FK PACKAGE
SN74LS625 ... FN PACKAGE
(TOP VIEW)

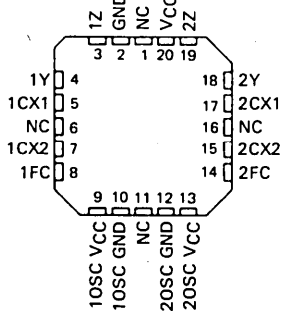

SN54LS626 ... FK PACKAGE
SN74LS626 ... FN PACKAGE
(TOP VIEW)

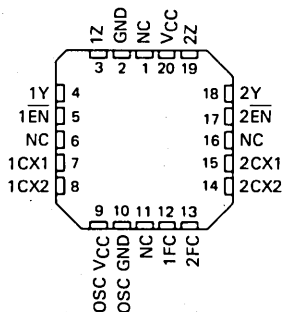

3

TTL DEVICES

TYPES SN54LS624 THRU SN54LS629, SN74LS624 THRU SN74LS629 VOLTAGE-CONTROLLED OSCILLATORS

SN54LS627 ... J OR W PACKAGE
SN74LS627 ... D, J OR N PACKAGE
(TOP VIEW)

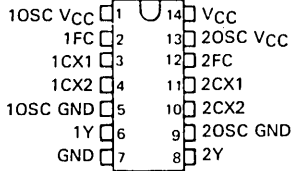

SN54LS628 ... J OR W PACKAGE
SN74LS628 ... D, J OR N PACKAGE
(TOP VIEW)

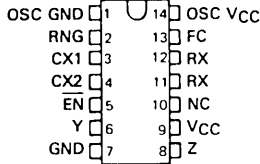

SN54LS629 ... J OR W PACKAGE
SN74LS629 ... D, J OR N PACKAGE
(TOP VIEW)

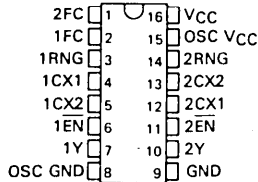

NC-No internal connection

SN54LS627 ... FK PACKAGE
SN74LS627 ... FN PACKAGE
(TOP VIEW)

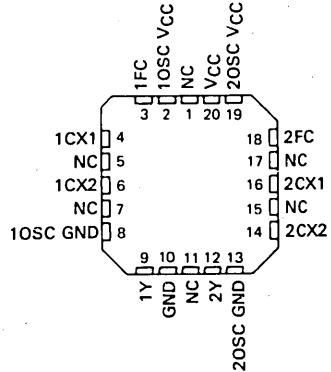

SN54LS628 ... FK PACKAGE
SN74LS628 ... FN PACKAGE
(TOP VIEW)

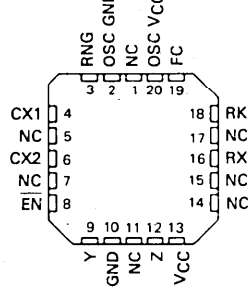

SN54LS629 ... FK PACKAGE
SN74LS629 ... FN PACKAGE
(TOP VIEW)

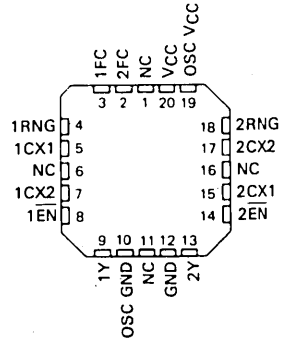

TTL DEVICES

TYPES SN54LS624 THRU SN54LS629, SN74LS624 THRU SN74LS629 VOLTAGE-CONTROLLED OSCILLATORS

logic diagram (positive logic)

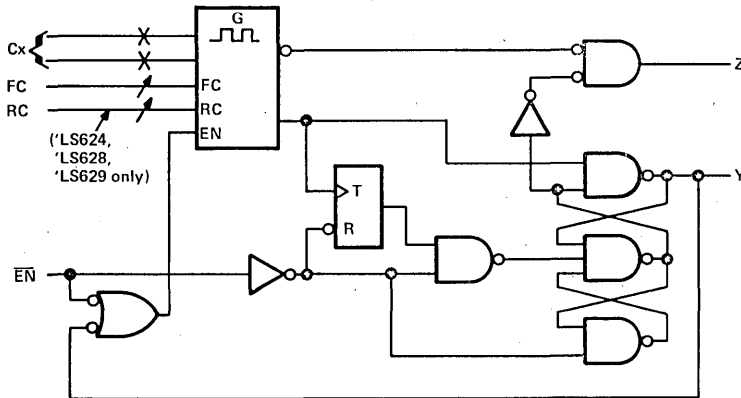

logic symbols

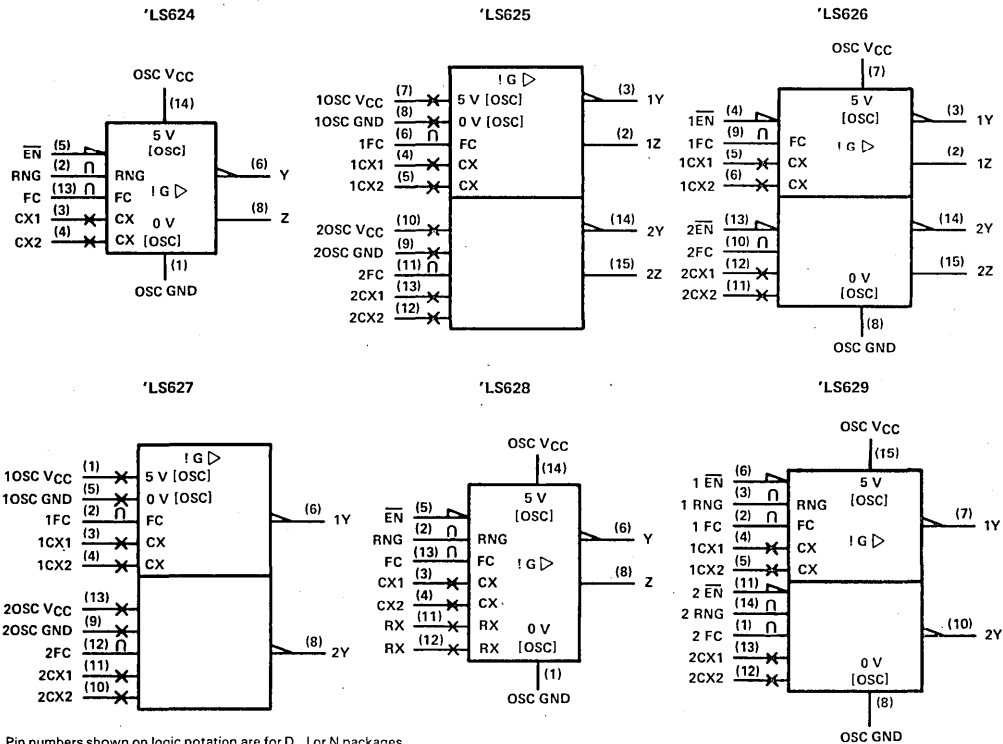

Pin numbers shown on logic notation are for D, J or N packages.

TYPES SN54LS624 THRU SN54LS629, SN74LS624 THRU SN74LS629 VOLTAGE-CONTROLLED OSCILLATORS

schematics of inputs and outputs

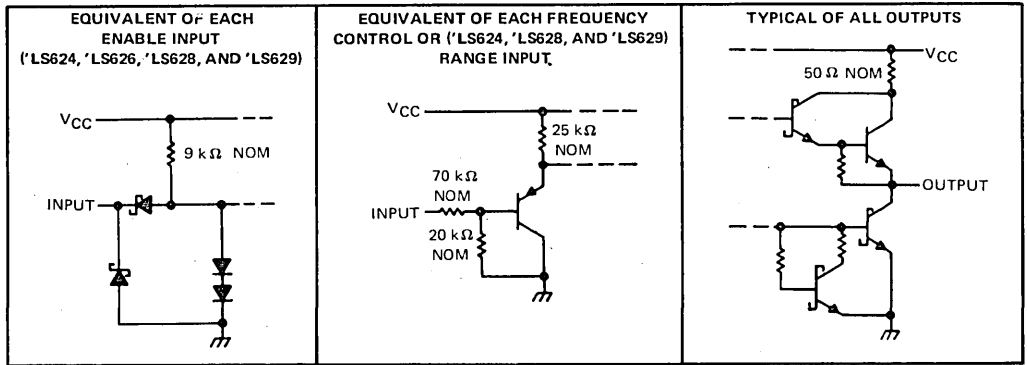

absolute maximum ratings over operating free-air temperature range (unless otherwise noted)

Supply voltage, V_{CC} (see Notes 1 and 2)	7 V
Input voltage: Enable input†	7 V
Frequency control or range input‡	V_{CC}
Operating free-air temperature range: SN54LS' Circuits	-55°C to 125°C
SN74LS' Circuits	0°C to 70°C
Storage temperature range	-65°C to 150°C

† The enable input is provided only on the 'LS624, 'LS626, 'LS628, and 'LS629.

‡ The range input is provided only on 'LS624, 'LS628, and 'LS629.

- NOTE: 1. Voltage values are with respect to the appropriate ground terminal.
2. Throughout the data sheet, the symbol V_{CC} is used for the voltage applied to both the V_{CC} and OSC V_{CC} terminals, unless otherwise noted.



TTL DEVICES

**TYPES SN54LS624 THRU SN54LS629,
SN74LS624 THRU SN74LS629
VOLTAGE-CONTROLLED OSCILLATORS**

recommended operating conditions

	SN54LS'			SN74LS'			UNIT
	MIN	NOM	MAX	MIN	NOM	MAX	
Supply voltage, V_{CC}	4.5	5	5.5	4.75	5	5.25	V
Input voltage at frequency control or range input, $V_{I(freq)}$ or $V_{I(rng)}$ [▲]	0		5	0		5	V
High-level output current, I_{OH}			-1.2			-1.2	mA
Low-level output current, I_{OL}			12			24	mA
Output frequency, f_o	1			1			Hz
	20			20			MHz
Operating free-air temperature, T_A	-55			125			70 °C

electrical characteristics over recommended operating free-air temperature range (unless otherwise noted)

PARAMETER		TEST CONDITIONS [†]	SN54LS'			SN74LS'			UNIT	
			MIN	TYP [‡]	MAX	MIN	TYP [‡]	MAX		
V_{IH}	High-level input voltage at enable [◆]		2			2			V	
V_{IL}	Low-level input voltage at enable [◆]		0.7			0.8			V	
V_{IK}	Input clamp voltage at enable [◆]	$V_{CC} = \text{MIN}, I_I = -18 \text{ mA}$	-1.5			-1.5			V	
V_{OH}	High-level output voltage	$V_{CC} = \text{MIN}, \overline{EN}$ at $V_{IL} \text{ max}, I_{OH} = -1.2 \text{ mA}$, See Note 3	2.5	3.4		2.7	3.4		V	
V_{OL}	Low-level output voltage	$V_{CC} = \text{MIN}, \overline{EN}$ at $V_{IL} \text{ max},$ See Note 3	$I_{OL} = 12 \text{ mA}$	0.25	0.4	0.25	0.4		V	
			$I_{OL} = 24 \text{ mA}$			0.35	0.5			
I_I	Input current	Freq control or range [▲]	$V_{CC} = \text{MAX}$		$V_I = 5 \text{ V}$	50	250	50	250	μA
I_I	Input current at maximum input voltage	Enable [◆]	$V_{CC} = \text{MAX}, V_I = 7 \text{ V}$			10	50	10	50	mA
I_{IH}	High-level input current	Enable [◆]	$V_{CC} = \text{MAX}, V_I = 2.7 \text{ V}$			40		40		μA
I_{IL}	Low-level input current	Enable [◆]	$V_{CC} = \text{MAX}, V_I = 0.4 \text{ V}$			-0.8		-0.8		mA
I_{OS}	Short-circuit output current [§]	$V_{CC} = \text{MAX}$	-40	-225		-40	-225		mA	
I_{CC}	Supply current, total into V_{CC} and OSC V_{CC} pins	$V_{CC} = \text{MAX}, \text{Enable}^{\text{◆}} = 4.5 \text{ V}$ See Note 4	'LS624	20	35	20	35		mA	
			'LS625	35	55	35	55			
			'LS626	35	55	35	55			
			'LS627	35	55	35	55			
			'LS628	20	35	20	35			
			'LS629	35	55	35	55			

[†] For conditions shown as MIN or MAX, use the appropriate value specified under recommended operating conditions.

[‡] All typical values are at $V_{CC} = 5 \text{ V}, T_A = 25^\circ\text{C}$.

[§] Not more than one output should be shorted at a time and duration of the short-circuit should not exceed one second.

[▲] The range input is provided only on the 'LS624, 'LS628, and 'LS629.

[◆] The enable input is provided only on the 'LS624, 'LS626, 'LS628, and 'LS629.

NOTES: 3. V_{OH} for Y outputs and V_{OL} for Z outputs are measured while enable inputs are connected to ground, with individual 1-k Ω resistors connected from CX1 to V_{CC} and from CX2 to ground. The resistor connections are reversed for testing V_{OH} for Z outputs and V_{OL} for Y inputs.

4. For 'LS624, 'LS626, 'LS628, and 'LS629, I_{CC} is measured with the outputs disabled and open. For 'LS625 and 'LS627, I_{CC} is measured with one OSC $V_{CC} = \text{MAX}$, and with the other OSC V_{CC} and outputs open.

TYPES SN54LS624 THRU SN54LS629, SN74LS624 THRU SN74LS629 VOLTAGE-CONTROLLED OSCILLATORS

switching characteristics, $V_{CC} = 5\text{ V}$ (unless otherwise noted), $R_L = 667\ \Omega$, $C_L = 45\text{ pF}$, $T_A = 25\text{ }^\circ\text{C}$

PARAMETER	TEST CONDITIONS			'LS624, 'LS628, 'LS629			'LS625, 'LS626, 'LS627			UNIT	
				MIN	TYP	MAX	MIN	TYP	MAX		
f_o Output frequency	$C_{ext} = 50\text{ pF}$	$V_I(\text{freq}) = 5\text{ V}, V_I(\text{rng}) = 0\text{ V}$			15	20	25			MHz	
		$V_I(\text{freq}) = 1\text{ V}, V_I(\text{rng}) = 5\text{ V}$			1.1	1.6	2.1				
		$V_I(\text{freq}) = 5\text{ V}$						7	9.5		12
		$V_I(\text{freq}) = 0\text{ V}$						0.9	1.2		1.5

TYPICAL CHARACTERISTICS

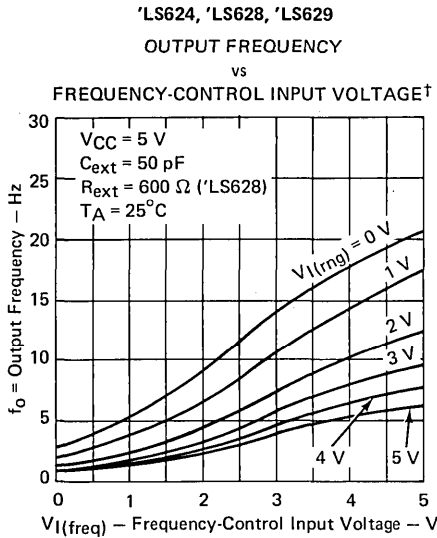

FIGURE 1

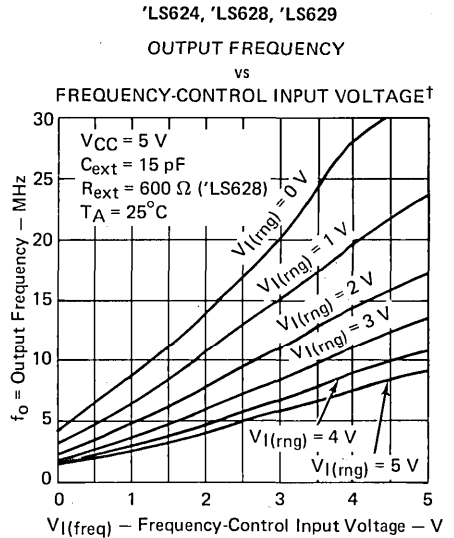

FIGURE 2

† Due to the effects of stray capacitance the output frequency may be unstable when the frequency control voltage is less than 1 volt.

**TYPES SN54LS624 THRU SN54LS629,
SN74LS624 THRU SN74LS629
VOLTAGE-CONTROLLED OSCILLATORS**

TYPICAL CHARACTERISTICS

'LS624, 'LS623, 'LS629

OUTPUT FREQUENCY

vs

EXTERNAL CAPACITANCE

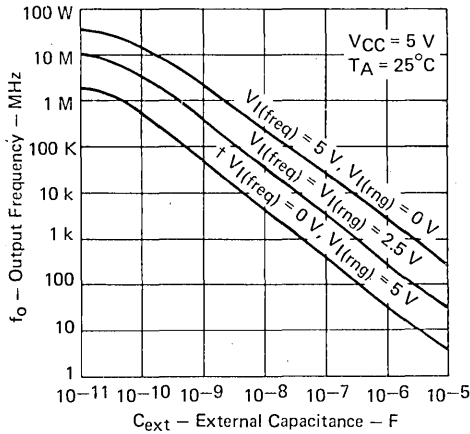

FIGURE 3

'LS625, 'LS626, 'LS627

OUTPUT FREQUENCY

vs

FREQUENCY-CONTROL INPUT VOLTAGE †

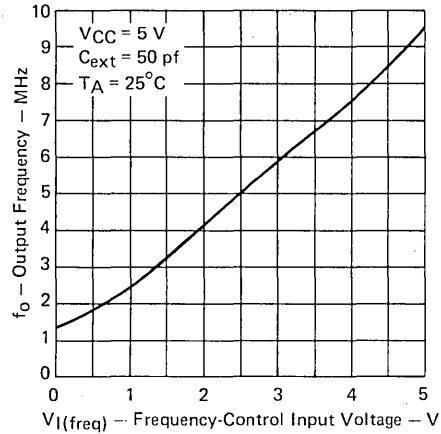

FIGURE 4

'LS625, 'LS626, 'LS627

OUTPUT FREQUENCY

vs

FREQUENCY-CONTROL INPUT VOLTAGE

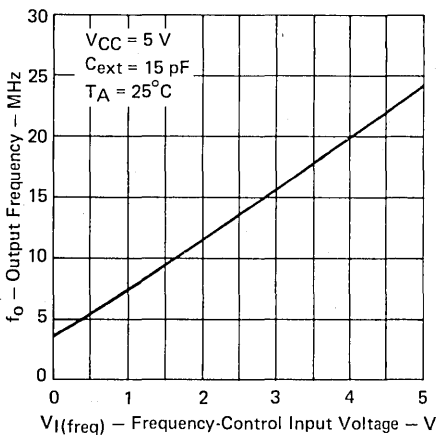

FIGURE 5

'LS625, 'LS626, 'LS627

OUTPUT FREQUENCY

vs

EXTERNAL CAPACITANCE

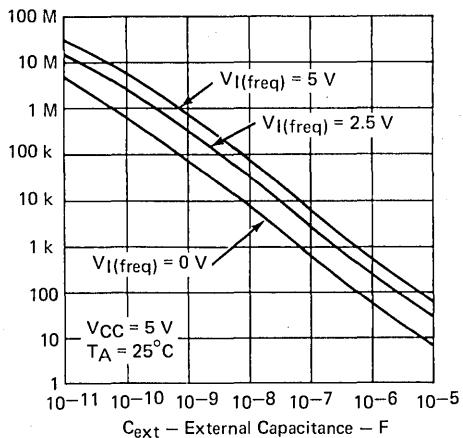

FIGURE 6

† Due to the effects of stray capacitance the output frequency may be unstable when the frequency control voltage is less than 1 volt.

3 TTL DEVICES

TYPES SN54LS624 THRU SN54LS629,
SN74LS624 THRU SN74LS629
VOLTAGE-CONTROLLED OSCILLATORS

TYPICAL CHARACTERISTICS

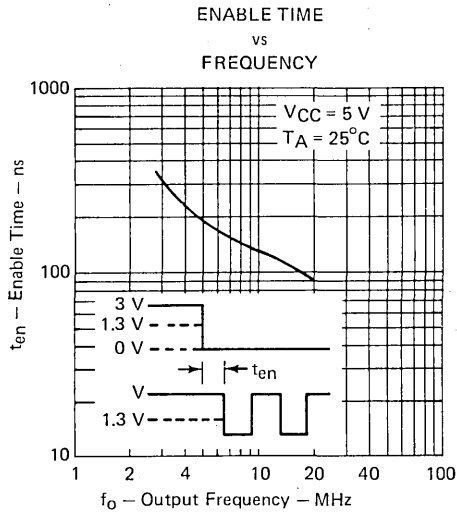
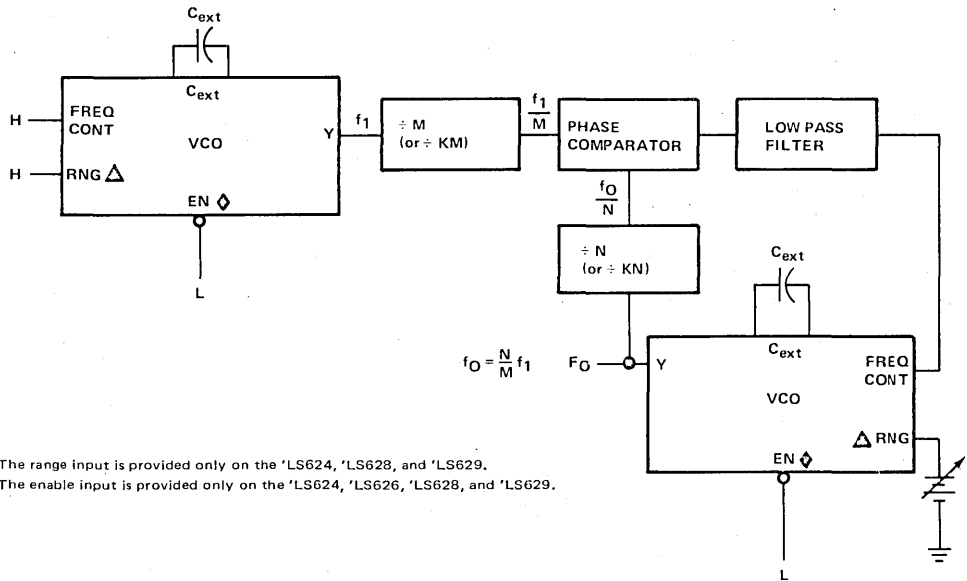

FIGURE 7

TYPICAL APPLICATIONS DATA



- ▲ The range input is provided only on the 'LS624, 'LS628, and 'LS629.
- ◆ The enable input is provided only on the 'LS624, 'LS626, 'LS628, and 'LS629.

FIGURE A—PHASE-LOCKED LOOP



TTL DEVICES

TYPES SN54LS630, SN54LS631, SN74LS630, SN74LS631 16-BIT PARALLEL ERROR DETECTION AND CORRECTION CIRCUITS

D2550, MARCH 1980—REVISED APRIL 1985

(TIM99630, TIM99631)

- Detects and Corrects Single-Bit Errors
- Detects and Flags Dual-Bit Errors
- Fast Processing Times:
 - Write Cycle: Generates Check Word in 45 ns Typical
 - Read Cycle: Flags Errors in 27 ns Typical
- Power Dissipation 600 mW Typical
- Choice of Output Configurations:
 - 'LS630 . . . 3-State
 - 'LS631 . . . Open-Collector

description

The 'LS630 and 'LS631 devices are 16-bit parallel error detection and correction circuits (EDACs) in 28-pin, 600-mil packages. They use a modified Hamming code to generate a 6-bit check word from a 16-bit data word. This check word is stored along with the data word during the memory write cycle. During the memory read cycle, the 22-bit words from memory are processed by the EDACs to determine if errors have occurred in memory.

Single-bit errors in the 16-bit data word are flagged and corrected.

Single-bit errors in the 6-bit check word are flagged, and the CPU sends the EDAC through the correction cycle even though the 16-bit word is not in error. The correction cycle will simply pass along the original 16-bit word in this case and produce error syndrome bits to pinpoint the error-generating location.

Dual-bit errors are flagged but not corrected. These dual errors may occur in any two bits of the 22-bit word from memory (two errors in the 16-bit data word, two errors in the 6-bit check word, or one error in each word).

The gross-error condition of all lows or all highs from memory will be detected. Otherwise, errors in three or more bits of the 22-bit word are beyond the capabilities of these devices to detect.

SN54LS630, SN54LS631 . . . JD PACKAGE
SN74LS630, SN74LS631 . . . JD OR N PACKAGE
(TOP VIEW)

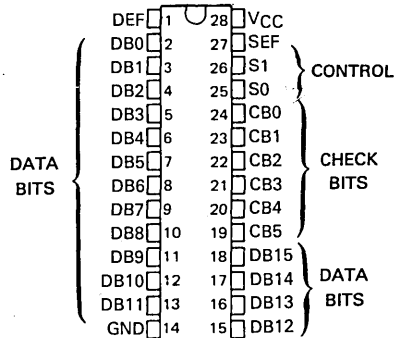

SN54LS630, SN54LS631 . . . FK PACKAGE
SN74LS630, SN74LS631 . . . FN PACKAGE
(TOP VIEW)

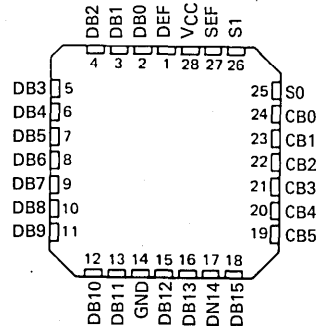

CONTROL FUNCTION TABLE

Memory Cycle	Control		EDAC Function	Data I/O	Check Word I/O	Error Flags	
	S1	S0				SEF	DEF
WRITE	L	L	Generate Check Word	Input Data	Output Check Word	L	L
READ	L	H	Read Data & Check Word	Input Data	Input Check Word	L	L
READ	H	H	Latch & Flag Errors	Latch Data	Latch Check Word	Enabled	
READ	H	L	Correct Data Word & Generate Syndrome Bits	Output Corrected Data	Output Syndrome Bits	Enabled	

PRODUCTION DATA
This document contains information current as of publication date. Products conform to specifications per the terms of Texas Instruments standard warranty. Production processing does not necessarily include testing of all parameters.

**TEXAS
INSTRUMENTS**

POST OFFICE BOX 225012 • DALLAS, TEXAS 75265

3-1213

TTL DEVICES

TYPES SN54LS630, SN54LS631, SN74LS630, SN74LS631

16-BIT PARALLEL ERROR DETECTION AND CORRECTION CIRCUITS

functional block diagram

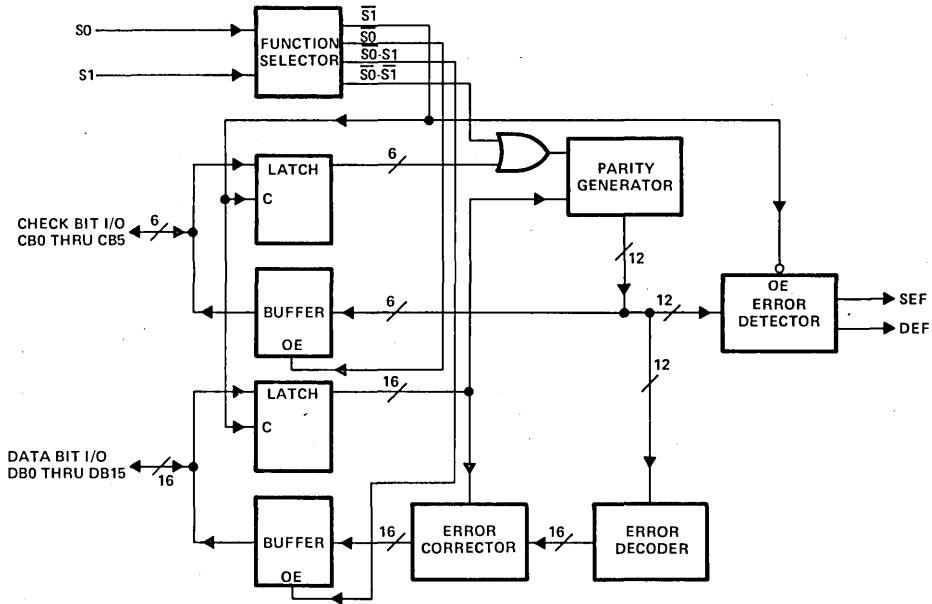

ERROR FUNCTION TABLE

Total Number of Errors		Error Flags		Data Correction
16-Bit Data	6-Bit Checkword	SEF	DEF	
0	0	L	L	Not Applicable
1	0	H	L	Correction
0	1	H	L	Correction
1	1	H	H	Interrupt
2	0	H	H	Interrupt
0	2	H	H	Interrupt

In order to be able to determine whether the data from the memory is acceptable to use as presented to the bus, the EDAC must be strobed to enable the error flags and the flags will have to be tested for the zero condition.

The first case in the error function table represents the normal, no-error condition. The CPU sees lows on both flags. The next two cases of single-bit errors require data correction. Although the EDAC can discern the single check bit error and ignore it, the error flags are identical to the single error in the 16-bit data word. The CPU will ask for data correction in both cases. An interrupt condition to the CPU results in each of the last three cases, where dual errors occur.

error detection and correction details

During a memory write cycle, six check bits (CB0-CB5) are generated by eight-input parity generators using the data bits as defined below. During a memory read cycle, the 6-bit check word is retrieved along with the actual data.

TYPES SN54LS630, SN54LS631, SN74LS630, SN74LS631 16-BIT PARALLEL ERROR DETECTION AND CORRECTION CIRCUITS

CHECKWORD BIT	16-BIT DATA WORD															
	0	1	2	3	4	5	6	7	8	9	10	11	12	13	14	15
CB0	x	x		x	x				x	x	x				x	
CB1	x		x	x		x	x		x			x				x
CB2		x	x		x	x		x		x			x			x
CB3	x	x	x				x	x			x	x	x			
CB4				x	x	x	x	x						x	x	x
CB5									x	x	x	x	x	x	x	x

The six check bits are parity bits derived from the matrix of data bits as indicated by "x" for each bit.

Error detection is accomplished as the 6-bit check word and the 16-bit data word from memory are applied to internal parity generators/checkers. If the parity of all six groupings of data and check bits are correct, it is assumed that no error has occurred and both error flags will be low. (It should be noted that the sense of two of the check bits, bits CB0 and CB1, is inverted to ensure that the gross-error condition of all lows and all highs is detected.)

If the parity of one or more of the check groups is incorrect, an error has occurred and the proper error flag or flags will be set high. Any single error in the 16-bit data word will change the sense of exactly three bits of the 6-bit check word. Any single error in the 6-bit check word changes the sense of only that one bit. In either case, the single error flag will be set high while the dual error flag will remain low.

Any two-bit error will change the sense of an even number of check bits. The two-bit error is not correctable since the parity tree can only identify single-bit errors. Both error flags are set high when any two-bit error is detected.

Three or more simultaneous bit errors can fool the EDAC into believing that no error, a correctable error, or an uncorrectable error has occurred and produce erroneous results in all three cases.

Error correction is accomplished by identifying the bad bit and inverting it. Identification of the erroneous bit is achieved by comparing the 16-bit data word and 6-bit check word from memory with the new check word with one (check word error) or three (data word error) inverted bits.

As the corrected word is made available on the data word I/O port, the check word I/O port presents a 6-bit syndrome error code. This syndrome code can be used to identify the bad memory chip.

ERROR SYNDROME TABLE

ERROR LOCATION	SYNDROME ERROR CODE					
	CB0	CB1	CB2	CB3	CB4	CB5
DB0	L	L	H	L	H	H
DB1	L	H	L	L	H	H
DB2	H	L	L	L	H	H
DB3	L	L	H	H	L	H
DB4	L	H	L	H	L	H
DB5	H	L	L	H	L	H
DB6	H	L	H	L	L	H
DB7	H	H	L	L	L	H
DB8	L	L	H	H	H	L
DB9	L	H	L	H	H	L
DB10	L	H	H	L	H	L
DB11	H	L	H	L	H	L
DB12	H	H	L	L	H	L
DB13	L	H	H	H	L	L
DB14	H	L	H	H	L	L
DB15	H	H	L	H	L	L
CB0	L	H	H	H	H	H
CB1	H	L	H	H	H	H
CB2	H	H	L	H	H	H
CB3	H	H	H	L	H	H
CB4	H	H	H	H	L	H
CB5	H	H	H	H	H	L
NO ERROR	H	H	H	H	H	H

3

TTL DEVICES

TYPES SN54LS630, SN54LS631, SN74LS630, SN74LS631

16-BIT PARALLEL ERROR DETECTION AND CORRECTION CIRCUITS

schematics of inputs and outputs

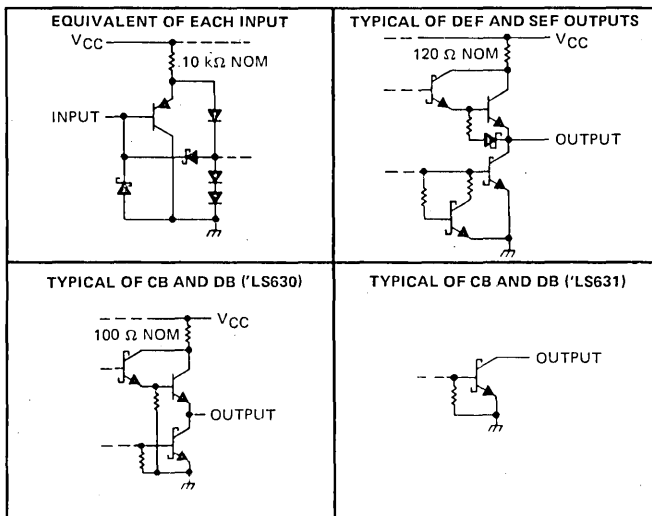

absolute maximum ratings over operating free-air temperature range (unless otherwise noted)

Supply voltage, V_{CC} (see Note 1)	7 V
Input voltage: S0 and S1	7 V
CB and DB	5.5 V
Off-state output voltage	5.5 V
Operating free-air temperature range: SN54LS630, SN54LS631	-55°C to 125°C
SN74LS630, SN74LS631	0°C to 70°C
Storage temperature range	-65°C to 150°C

NOTE 1: Voltage values are with respect to network ground terminal.

recommended operating conditions

		SN54LS630 SN54LS631			SN74LS630 SN74LS631			UNIT
		MIN	NOM	MAX	MIN	NOM	MAX	
V_{CC}	Supply voltage	4.5	5	5.5	4.75	5	5.25	V
I_{OH}	High-level output current	CB or DB, 'LS630 only			DEF or SEF			mA
		-1			-0.4			
V_{OH}	High-level output voltage	CB or DB, 'LS631 only			DEF or SEF			V
		5.5			5.5			
I_{OL}	Low-level output current	CB or DB			DEF or SEF			mA
		12			8			
t_{su}	Setup time	CB or DB before S1†			DEF or SEF			ns
		15			15			
		CB or DB before S1††			DEF or SEF			ns
		45			45			
t_h	Hold time	CB or DB after S1†			DEF or SEF			ns
		15			15			
T_A	Operating free-air temperature	-55			125			°C

† This time guarantees the input data and checkword will be latched.

‡ This time guarantees the input data and checkword will be latched plus that no glitch will occur on SEF or DEF flags.

† The upward-pointing arrow indicates a transition from low to high.

TYPES SN54LS630, SN54LS631, SN74LS630, SN74LS631 16-BIT PARALLEL ERROR DETECTION AND CORRECTION CIRCUITS

electrical characteristics over recommended operating free-air temperature range (unless otherwise noted)

PARAMETERS		TEST CONDITIONS †		SN54LS630		SN74LS630		UNIT	
				MIN	TYP ‡	MAX	MIN		TYP ‡
V _{IH}	High-level input voltage			2		2		V	
V _{IL}	Low-level input voltage			0.7		0.8		V	
V _{IK}	Input clamp voltage	V _{CC} = MIN, I _I = -18 mA		-1.5		-1.5		V	
V _{OH}	High-level output voltage	CB or DB DEF or SEF	V _{CC} = MIN, V _{IH} = 2 V, V _{IL} = V _{IL min}	I _{OH} = MAX	2.4 3.3		2.4 3.2		V
				I _{OH} = -400 µA	2.5 3.4		2.7 3.4		
V _{OL}	Low-level output voltage	CB or DB	V _{CC} = MIN, V _{IH} = 2 V, V _{IL} = V _{IL max}	I _{OL} = 12 mA	0.25 0.4		0.25 0.4		V
				I _{OL} = 24 mA			0.35 0.5		
		DEF or SEF		I _{OL} = 4 mA	0.25 0.4		0.25 0.4		
				I _{OL} = 8 mA			0.35 0.5		
I _{OZH}	Off-state output current, high-level voltage applied	CB or DB	V _{CC} = MAX, S ₀ and S ₁ at 2 V, V _O = 2.7 V	20		20		µA	
I _{OZL}	Off-state output current, low-level voltage applied	CB or DB	V _{CC} = MAX, S ₀ and S ₁ at 2 V, V _O = 0.4 V	-200		-200		µA	
I _I	Input current at maximum input voltage	CB or DB S ₀ or S ₁	V _I = 5.5 V	0.1		0.1		mA	
			V _I = 7 V	0.1		0.1			
I _{IH}	High-level input current	V _{CC} = MAX, V _I = 2.7 V		20		20		µA	
I _{IL}	Low-level input current	V _{CC} = MAX, V _I = 0.4 V		-0.2		-0.2		mA	
I _{OS} §	Short-circuit output current	CB or DB DEF or SEF	V _{CC} = MAX	-30	-130	-30	-130	mA	
				-20	-100	-20	-100		
I _{CC}	Supply current	V _{CC} = MAX, S ₀ and S ₁ at 4.5 V, All CB and DB pins grounded, DEF and SEF open		143 230		143 230		mA	

electrical characteristics over recommended operating free-air temperature range (unless otherwise noted)

PARAMETER		TEST CONDITIONS †		SN54LS631		SN74LS631		UNIT	
				MIN	TYP ‡	MAX	MIN		TYP ‡
V _{IH}	High-level input voltage			2		2		V	
V _{IL}	Low-level input voltage			0.7		0.8		V	
V _{IK}	Input clamp voltage	V _{CC} = MIN, I _I = -18 mA		-1.5		-1.5		V	
V _{OH}	High-level output voltage	DEF or SEF	V _{CC} = MIN, V _{IH} = 2 V, V _{IL} = V _{IL max}	2.5	3.4	2.7	3.4	V	
I _{OH}	High-level output current	CB or DB	V _{CC} = MIN, V _{IH} = 2 V, V _{IL} = V _{IL max}	100		100		µA	
V _{OL}	Low-level output voltage	CB or DB	V _{CC} = MIN, V _{IH} = 2 V, V _{IL} = V _{IL max}	I _{OL} = 12 mA	0.25 0.4		0.25 0.4		V
				I _{OL} = 24 mA			0.35 0.5		
		DEF or SEF		I _{OL} = 4 mA	0.25 0.4		0.25 0.4		
				I _{OL} = 8 mA			0.35 0.5		
I _I	Input current at maximum input voltage	CB or DB S ₀ or S ₁	V _I = 5.5 V	0.1		0.1		mA	
			V _I = 7 V	0.1		0.1			
I _{IH}	High-level input current	V _{CC} = MAX, V _I = 2.7 V		20		20		µA	
I _{IL}	Low-level input current	V _{CC} = MAX, V _I = 0.4 V		-0.2		-0.2		mA	
I _{OS} §	Short-circuit output current	DEF or SEF	V _{CC} = MAX	-20	-100	-20	-100	mA	
I _{CC}	Supply current	V _{CC} = MAX, S ₀ and S ₁ at 4.5 V, All CB and DB grounded, SEF and DEF open		113 180		113 180		mA	

† For conditions shown as MIN or MAX, use the appropriate value specified under recommended operating conditions.

‡ All typical values are at V_{CC} = 5 V, T_A = 25°C.

§ Not more than one output should be shorted at a time, and duration of the short circuit should not exceed one second.

3

TTL DEVICES

TYPES SN54LS630, SN54LS631, SN74LS630, AND SN74LS631

16-BIT PARALLEL ERROR DETECTION AND CORRECTION CIRCUITS

switching characteristics, $V_{CC} = 5\text{ V}$, $T_A = 25^\circ\text{C}$, $C_L = 45\text{ pF}$

PARAMETER	FROM (INPUT)	TO (OUTPUT)	TEST CONDITIONS	'LS630			UNIT
				MIN	TYP	MAX	
t_{pLH} Propagation delay time, low-to-high-level output [◇]	DB	CB	S_0 at 0 V, S_1 at 0 V, $R_L = 667\ \Omega$, See Figure 1	31	65	ns	
t_{pHL} Propagation delay time, high-to-low-level output [◇]				45	65		
t_{pLH} Propagation delay time, low-to-high-level output*	S1↑	DEF	S_0 at 3 V, $R_L = 2\text{ k}\Omega$, See Figure 1	27	40	ns	
		SEF		20	30		
t_{pZH} Output enable time to high level [#]	S0↓	CB, DB	S_1 at 3 V, $R_L = 667\ \Omega$, See Figure 2	24	40	ns	
t_{pZL} Output enable time to low level [#]	S0↓	CB, DB	S_1 at 3 V, $R_L = 667\ \Omega$, See Figure 1	30	45	ns	
t_{pHZ} Output disable time from high level [▲]	S0↑	CB, DB	S_1 at 3 V, $R_L = 667\ \Omega$, See Figure 2	43	65	ns	
t_{pLZ} Output disable time from low level [▲]	S0↑	CB, DB	S_1 at 3 V, $R_L = 667\ \Omega$, See Figure 1	31	65	ns	

switching characteristics, $V_{CC} = 5\text{ V}$, $T_A = 25^\circ\text{C}$, $C_L = 45\text{ pF}$, see Figure 1

PARAMETER	FROM (INPUT)	TO (OUTPUT)	TEST CONDITIONS	'LS631			UNIT
				MIN	TYP	MAX	
t_{pLH} Propagation delay time, low-to-high level output [◇]	DB	CB	S_0 at 0 V, S_1 at 0 V, $R_L = 667\ \Omega$	38	55	ns	
t_{pHL} Propagation delay time, high-to-low-level output [◇]				45	65		
t_{pLH} Propagation delay time, low-to-high-level output*	S1↑	DEF	S_0 at 3 V, $R_L = 2\text{ k}\Omega$	27	40	ns	
		SEF		20	30		
t_{pHL} Propagation delay time, high-to-low-level output [#]	S0↓	CB, DB	S_1 at 3 V, $R_L = 667\text{ k}\Omega$	28	45	ns	
t_{pLH} Propagation delay time, low-to-high-level output [▲]	S0↑	CB, DB	S_1 at 3 V, $R_L = 667\text{ k}\Omega$	33	50	ns	

[◇]These parameters describe the time intervals taken to generate the check word during the memory write cycle.

*These parameters describe the time intervals taken to flag errors during the memory read cycle.

[#]These parameters describe the time intervals taken to correct and output the data word and to generate and output the syndrome error code during the memory read cycle.

[▲]These parameters describe the time intervals taken to disable the CB and DB buses in preparation for a new data word during the memory read cycle.

PARAMETER MEASUREMENT INFORMATION

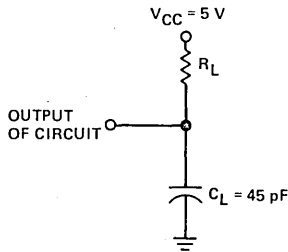

FIGURE 1—OUTPUT LOAD CIRCUIT

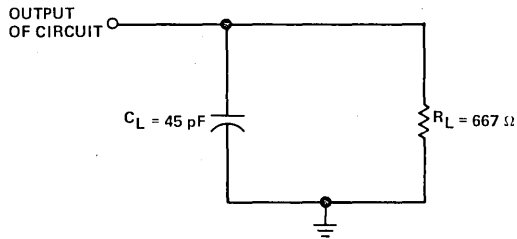
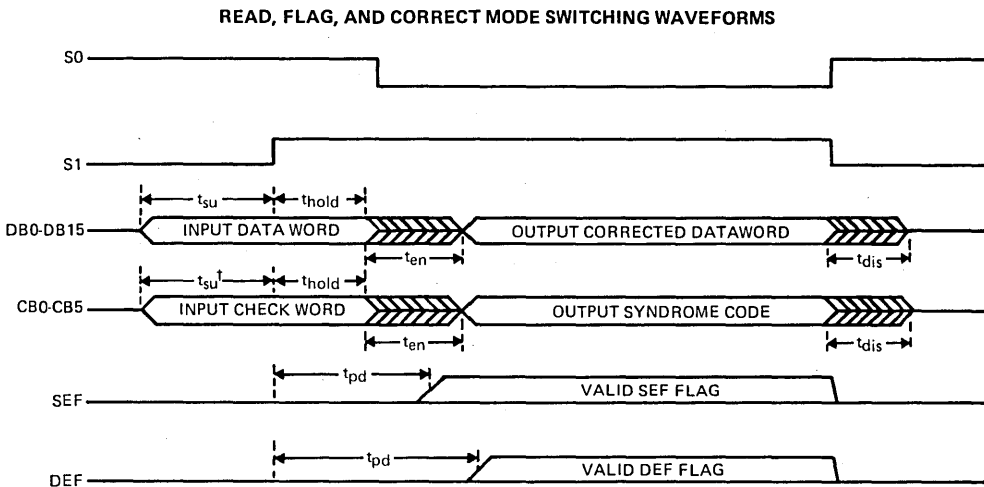

FIGURE 2—OUTPUT LOAD CIRCUIT

TYPES SN54LS630, SN54LS631, SN74LS630, SN74LS631 16-BIT PARALLEL ERROR DETECTION AND CORRECTION CIRCUITS

typical operating sequences



† NOTE: There are two conditions specified for t_{su} of Data or Checkword before S1† See recommended operating conditions for details.

3

TTL DEVICES

TYPES SN54LS636, SN54LS637, SN74LS636, SN74LS637 8-BIT PARALLEL ERROR DETECTION AND CORRECTION CIRCUITS

D2728, APRIL 1983, REVISED DECEMBER 1983

- Detects and Corrects Single-Bit Errors
- Detects and Flags Dual-Bit Errors
- Fast Processing Times:
 - Write Cycle: Generates Check Word in
45 ns Typical
 - Read Cycle: Flags Errors in 27 ns
Typical
- Power Dissipation 500 mW Typical
- Choice of Output Configurations:
 - 'LS636 . . . 3-State
 - 'LS637 . . . Open Collector

SN54LS' . . . J PACKAGE
SN74LS' . . . DW, J OR N PACKAGE
(TOP VIEW)

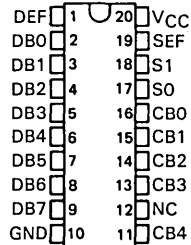

SN54LS' . . . FK PACKAGE
SN74LS' . . . FN PACKAGE
(TOP VIEW)

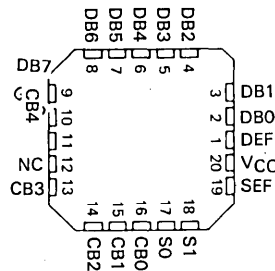

NC—No internal connection.

description

The 'LS636 and 'LS637 devices are 8-bit parallel error detection and correction circuits (EDACs) in 20-pin, 300-mil packages. They use a modified Hamming code to generate a 5-bit check word from an 8-bit data word. This check word is stored along with the data word during the memory write cycle. During the memory read cycle, the 13-bit words from memory are processed by the EDACs to determine if errors have occurred in memory.

Single-bit errors in the 8-bit data word are flagged and corrected.

Single-bit errors in the 5-bit check word are flagged, and the CPU sends the EDAC through the correction cycle even though the 8-bit word is not in error. The correction cycle will simply pass along the original 8-bit word in this case and produce error syndrome bits to pinpoint the error-generating location.

Dual-bit errors are flagged but not corrected. These dual errors may occur in any two bits of the 13-bit word from memory (two errors in the 8-bit data word, two errors in the 5-bit check word, or one error in each word).

The gross-error condition of all highs from memory will be detected. Otherwise, errors in three or more bits of the 13-bit word are beyond the capabilities of these devices to detect.

CONTROL FUNCTION TABLE

MEMORY CYCLE	CONTROL		EDAC FUNCTION	DATA I/O	CHECK WORD I/O	ERROR FLAGS	
	S1	S0				SEF	DEF
WRITE	L	L	Generate Check Word	Input Data	Output Check Word	L	L
READ	L	H	Read Data & Check Word	Input Data	Input Check Word	L	L
READ	H	H	Latch & Flag Errors	Latch Data	Latch Check Word	Enabled	
READ	H	L	Correct Data Word & Generate Syndrome Bits	Output Corrected Data	Output Syndrome Bits	Enabled	

PRODUCTION DATA
This document contains information current as of publication date. Products conform to specifications per the terms of Texas Instruments standard warranty. Production processing does not necessarily include testing of all parameters.

**TEXAS
INSTRUMENTS**

POST OFFICE BOX 225012 • DALLAS, TEXAS 75265

3-1221

TYPES SN54LS636, SN54LS637, SN74LS636, SN74LS637

8-BIT PARALLEL ERROR DETECTION AND CORRECTION CIRCUITS

functional block diagram

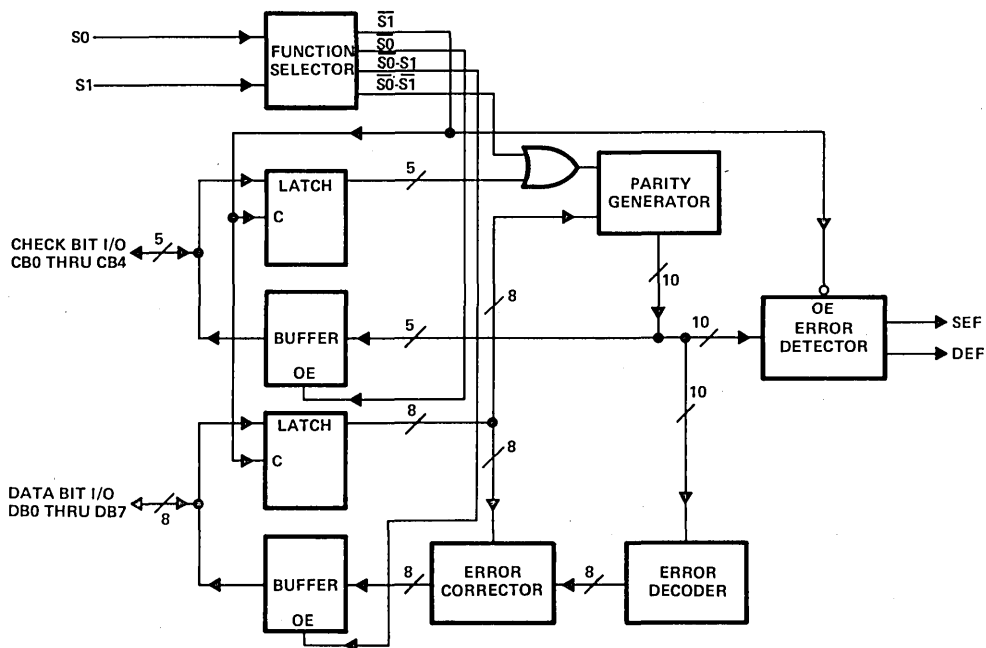

ERROR FUNCTION TABLE

TOTAL NUMBER OF ERRORS		ERROR FLAGS		DATA CORRECTION
8-BIT DATA	5-BIT CHECKWORD	SEF	DEF	
0	0	L	L	Not Applicable
1	0	H	L	Correction
0	1	H	L	Correction
1	1	H	H	Interrupt
2	0	H	H	Interrupt
0	2	H	H	Interrupt

In order to be able to determine whether the data from the memory is acceptable to use as presented to the bus, the EDAC must be strobed to enable the error flags and the flags will have to be tested for the zero condition.

The first case in the error function table represents the normal, no-error condition. The CPU sees lows on both flags. The next two cases of single-bit errors require data correction. Although the EDAC can discern the single check bit error and ignore it, the error flags are identical to the single error in the 8-bit data word. The CPU will ask for data correction in both cases. An interrupt condition to the CPU results in each of the last three cases, where dual errors occur.

error detection and correction details

During a memory write cycle, five check bits (CB0-CB4) are generated by eight-input parity generators using the data bits as defined below. During a memory read cycle, the 5-bit check word is retrieved along with the 8-bit data word.

TYPES SN54LS636, SN54LS637, SN74LS636, SN74LS637

8-BIT PARALLEL ERROR DETECTION AND CORRECTION CIRCUITS

CHECKWORD BIT	8-BIT DATA WORD							
	0	1	2	3	4	5	6	7
CB0	X	X		X	X			
CB1	X		X	X		X	X	
CB2		X	X		X	X		X
CB3	X	X	X				X	X
CB4				X	X	X	X	X

The five check bits are parity bits derived from the matrix of data bits as indicated by "X" for each bit.

Error detection is accomplished as the 5-bit check word and the 8-bit data word from memory are applied to internal parity generators/checkers. If the parity of all five groupings of data and check bits are correct, it is assumed that no error has occurred and both error flags will be low.

If the parity of one or more of the check groups is incorrect, an error has occurred and the proper error flag or flags will be set high. Any single error in the 8-bit data word will change the sense of exactly three bits of the 5-bit check word. Any single error in the 5-bit check word changes the sense of only that one bit. In either case, the single error flag will be set high while the dual error flag will remain low.

Any two-bit error will change the sense of an even number of check bits. The two-bit error is not correctable since the parity tree can only identify single-bit errors. Both error flags are set high when any two-bit error is detected.

Three or more simultaneous bit errors can fool the EDAC into believing that no error, a correctable error, or an uncorrectable error has occurred and produce erroneous results in all three cases.

Error correction is accomplished by identifying the bad bit and inverting it. Identification of the erroneous bit is achieved by comparing the 8-bit data word and 5-bit check word from memory with the new check word with one (check word error) or three (data word error) inverted bits.

As the corrected word is made available on the data word I/O port, the check word I/O port presents a 5-bit syndrome error code. This syndrome code can be used to identify the bad memory chip.

ERROR SYNDROME TABLE

ERROR LOCATION	SYNDROME ERROR CODE				
	CB0	CB1	CB2	CB3	CB4
DB0	L	L	H	L	H
DB1	L	H	L	L	H
DB2	H	L	L	L	H
DB3	L	L	H	H	L
DB4	L	H	L	H	L
DB5	H	L	L	H	L
DB6	H	L	H	L	L
DB7	H	H	L	L	L
CB0	L	H	H	H	H
CB1	H	L	H	H	H
CB2	H	H	L	H	H
CB3	H	H	H	L	H
CB4	H	H	H	H	L
NO ERROR	H	H	H	H	H



TTL DEVICES

TYPES SN54LS636, SN54LS637, SN74LS636, SN74LS637

8-BIT PARALLEL ERROR DETECTION AND CORRECTION CIRCUITS

schematics of inputs and outputs

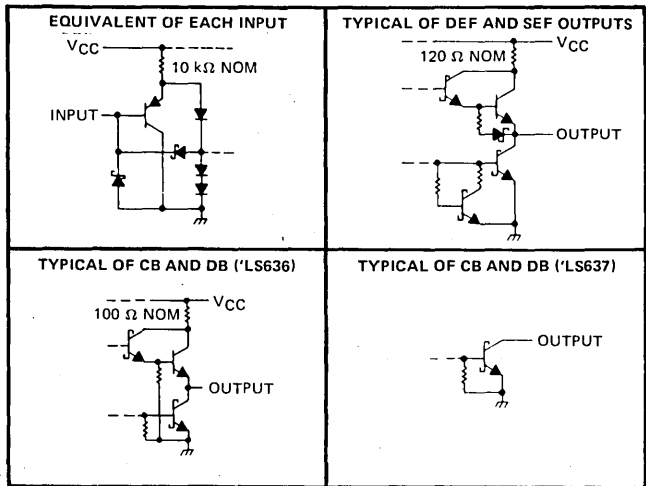

absolute maximum ratings over operating free-air temperature range (unless otherwise noted)

Supply voltage, V_{CC} (see Note 1)	7 V
Input voltage: S0 and S1	7 V
CB and DB	5.5 V
Off-state output voltage	5.5 V
Operating free-air temperature range: SN54LS636, SN54LS637	-55°C to 125°C
SN74LS636, SN74LS637	0°C to 70°C
Storage temperature range	-65°C to 150°C

NOTE 1: Voltage values are with respect to network ground terminal.

recommended operating conditions

		SN54LS636 SN54LS637			SN74LS636 SN74LS637			UNIT		
		MIN	NOM	MAX	MIN	NOM	MAX			
V_{CC}	Supply voltage	4.5	5	5.5	4.75	5	5.25	V		
I_{OH}	High-level output current	CB or DB, 'LS636 only			-1			mA		
		DEF or SEF			-0.4					
V_{OH}	High-level output voltage	CB or DB, 'LS637 only			5.5			V		
I_{OL}	Low-level output current	CB or DB			12			mA		
		DEF or SEF			4					
t_{su}	Setup time	CB or DB before S1††			15			ns		
		CB or DB before S1‡			45					
t_h	Hold time	CB or DB after S1†			15			ns		
T_A	Operating free-air temperature	-55			125			0	70	°C

† This time guarantees the input data and checkword will be latched.

‡ This time guarantees the input data and checkword will be latched plus that no glitch will occur on SEF or DEF flags.

† The upward-pointing arrow indicates a transition from low to high.

3

TTL DEVICES

TYPES SN54LS636, SN54LS637, SN74LS636, SN74LS637

8-BIT PARALLEL ERROR DETECTION AND CORRECTION CIRCUITS

electrical characteristics over recommended operating free-air temperature range (unless otherwise noted)

PARAMETERS		TEST CONDITIONS†	SN54LS636		SN74LS636		UNIT		
			MIN	TYP‡ MAX	MIN	TYP‡ MAX			
V _{IH}	High-level input voltage		2		2		V		
V _{IL}	Low-level input voltage		0.7		0.8		V		
V _{IK}	Input clamp voltage	V _{CC} = MIN, I _I = -18 mA	-1.5		-1.5		V		
V _{OH}	High-level output voltage	CB or DB DEF or SEF	V _{CC} = MIN, V _{IH} = 2 V, V _{IL} = V _{IL min}	I _{OH} = MAX	2.4	3.3	2.4	3.2	V
				I _{OH} = -400 µA	2.5	3.4	2.7	3.4	
V _{OL}	Low-level output voltage	CB or DB	V _{CC} = MIN, V _{IH} = 2 V, V _{IL} = V _{IL max}	I _{OL} = 12 mA	0.25	0.4	0.25	0.4	V
				I _{OL} = 24 mA			0.35	0.5	
		DEF or SEF		I _{OL} = 4 mA	0.25	0.4	0.25	0.4	
				I _{OL} = 8 mA			0.35	0.5	
I _{OZH}	Off-state output current, high-level voltage applied	CB or DB	V _{CC} = MAX, S ₀ and S ₁ at 2 V	V _O = 2.7 V		20	20	µA	
I _{OZL}	Off-state output current, low-level voltage applied	CB or DB	V _{CC} = MAX, S ₀ and S ₁ at 2 V	V _O = 0.4 V		-0.2	-0.2	mA	
I _I	Input current at maximum input voltage	CB or DB S ₀ or S ₁	V _{CC} = MAX,	V _I = 5.5 V	0.1		0.1	mA	
			V _{IH} = 4.5 V	V _I = 7 V	0.1		0.1		
I _{IH}	High-level input current		V _{CC} = MAX,	V _I = 2.7 V		20	20	µA	
I _{IL}	Low-level input current		V _{CC} = MAX,	V _I = 0.4 V		-0.2	-0.2	mA	
I _{OS} §	Short-circuit output current	CB or DB	V _{CC} = MAX		-30	-130	-30	-130	mA
		DEF or SEF			-20	-100	-20	-100	
I _{CC}	Supply current		V _{CC} = MAX, S ₀ and S ₁ at 4.5 V, All CB and DB pins grounded, DEF and SEF open		100	160	100	160	mA

PARAMETER		TEST CONDITIONS†	SN54LS637		SN74LS637		UNIT		
			MIN	TYP‡ MAX	MIN	TYP‡ MAX			
V _{IH}	High-level input voltage		2		2		V		
V _{IL}	Low-level input voltage		0.7		0.8		V		
V _{IK}	Input clamp voltage	V _{CC} = MIN, I _I = -18 mA	-1.5		-1.5		V		
V _{OH}	High-level output voltage	DEF or SEF	V _{CC} = MIN, V _{IH} = 2 V,	I _{OH} = -400 µA, V _{IL} = V _{IL max}	2.5	3.4	2.7	3.4	V
I _{OH}	High-level output current	CB or DB	V _{CC} = MIN, V _{IH} = 2 V,	V _{OH} = 5.5 V, V _{IL} = V _{IL max}	0.1		0.1	mA	
V _{OL}	Low-level output voltage	CB or DB	V _{CC} = MIN, V _{IH} = 2 V, V _{IL} = V _{IL max}	I _{OL} = 12 mA	0.25	0.4	0.25	0.4	V
				I _{OL} = 24 mA			0.35	0.5	
		DEF or SEF		I _{OL} = 4 mA	0.25	0.4	0.25	0.4	
				I _{OL} = 8 mA			0.35	0.5	
I _I	Input current at maximum input voltage	CB or DB S ₀ or S ₁	V _{CC} = MAX,	V _I = 5.5 V	0.1		0.1	mA	
			V _{IH} = 4.5 V	V _I = 7 V	0.1		0.1		
I _{IH}	High-level input current		V _{CC} = MAX	V _I = 2.7 V		20	20	µA	
I _{IL}	Low-level input current		V _{CC} = MAX,	V _I = 0.4 V		-0.2	-0.2	mA	
I _{OS} §	Short-circuit output current	DEF or SEF	V _{CC} = MAX		-20	-100	-20	-100	mA
I _{CC}	Supply current		V _{CC} = MAX, S ₀ and S ₁ at 4.5 V, All CB and DB grounded, SEF and DEF open		90	144	90	144	mA

† For conditions shown as MIN or MAX, use the appropriate value specified under recommended operating conditions.

‡ All typical values are at V_{CC} = 5 V, T_A = 25°C.

§ Not more than one output should be shorted at a time, and duration of the short circuit should not exceed one second.

**TEXAS
INSTRUMENTS**

POST OFFICE BOX 225012 • DALLAS, TEXAS 75265

3-1225

TTL DEVICES

TYPES SN54LS636, SN54LS637, SN74LS636, SN74LS637

8-BIT PARALLEL ERROR DETECTION AND CORRECTION CIRCUITS

'LS636 switching characteristics, $V_{CC} = 5\text{ V}$, $T_A = 25^\circ\text{C}$, $C_L = 45\text{ pF}$

PARAMETER	FROM (INPUT)	TO (OUTPUT)	TEST CONDITIONS	'LS636			UNIT
				MIN	TYP	MAX	
t_{PLH} Propagation delay time, low-to-high-level output [◇]	DB	CB	S_0 at 0 V, S_1 at 0 V, $R_L = 667\ \Omega$, See Figure 1	31	45	ns	
t_{PHL} Propagation delay time, high-to-low-level output [◇]				45	65		
t_{PLH} Propagation delay time, low-to-high-level output*	S_1 ↑	DEF	S_0 at 3 V, $R_L = 2\text{ k}\Omega$, See Figure 1	27	40	ns	
		SEF		20	30		
t_{PZH} Output enable time to high level [#]	S_0 ↓	CB, DB	S_1 at 3 V, $R_L = 667\ \Omega$, See Figure 2	24	40	ns	
t_{PZL} Output enable time to low level [#]	S_0 ↓	CB, DB	S_1 at 3 V, $R_L = 667\ \Omega$, See Figure 1	30	45	ns	
t_{PHZ} Output disable time from high level [▲]	S_0 ↑	CB, DB	S_1 at 3 V, $R_L = 667\ \Omega$, See Figure 2	43	65	ns	
t_{PLZ} Output disable time from low level [▲]	S_0 ↑	CB, DB	S_1 at 3 V, $R_L = 667\ \Omega$, See Figure 1	31	45	ns	

'LS637 switching characteristics, $V_{CC} = 5\text{ V}$, $T_A = 25^\circ\text{C}$, $C_L = 45\text{ pF}$, see Figure 1

PARAMETER	FROM (INPUT)	TO (OUTPUT)	TEST CONDITIONS	'LS637			UNIT
				MIN	TYP	MAX	
t_{PLH} Propagation delay time, low-to-high level output [◇]	DB	CB	S_0 at 0 V, S_1 at 0 V, $R_L = 667\ \Omega$	38	55	ns	
t_{PHL} Propagation delay time, high-to-low-level output [◇]				45	65		
t_{PLH} Propagation delay time, low-to-high-level output*	S_1 ↑	DEF	S_0 at 3 V, $R_L = 2\text{ k}\Omega$	27	40	ns	
		SEF		20	30		
t_{PHL} Propagation delay time, high-to-low-level output [#]	S_0 ↓	CB, DB	S_1 at 3 V, $R_L = 667\ \Omega$	28	45	ns	
t_{PLH} Propagation delay time, low-to-high-level output [▲]	S_0 ↑	CB, DB	S_1 at 3 V, $R_L = 667\ \Omega$	33	50	ns	

[◇]These parameters describe the time intervals taken to generate the check word during the memory write cycle.

*These parameters describe the time intervals taken to flag errors during the memory read cycle.

[#]These parameters describe the time intervals taken to correct and output the data word and to generate and output the syndrome error code during the memory read cycle.

[▲]These parameters describe the time intervals taken to disable the CB and DB buses in preparation for a new data word during the memory read cycle.

PARAMETER MEASUREMENT INFORMATION

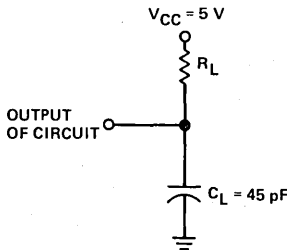

FIGURE 1—OUTPUT LOAD CIRCUIT

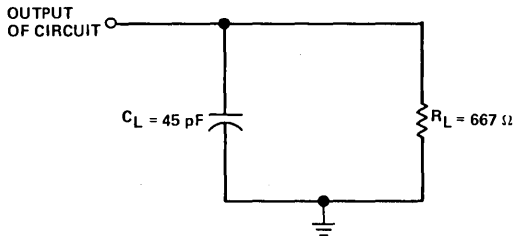

FIGURE 2—OUTPUT LOAD CIRCUIT

3
TTL DEVICES

TYPES SN54LS636, SN54LS637, SN74LS636, SN74LS637
 8-BIT PARALLEL ERROR DETECTION AND CORRECTION CIRCUITS

typical operating sequences

READ, FLAG, AND CORRECT MODE SWITCHING WAVEFORMS

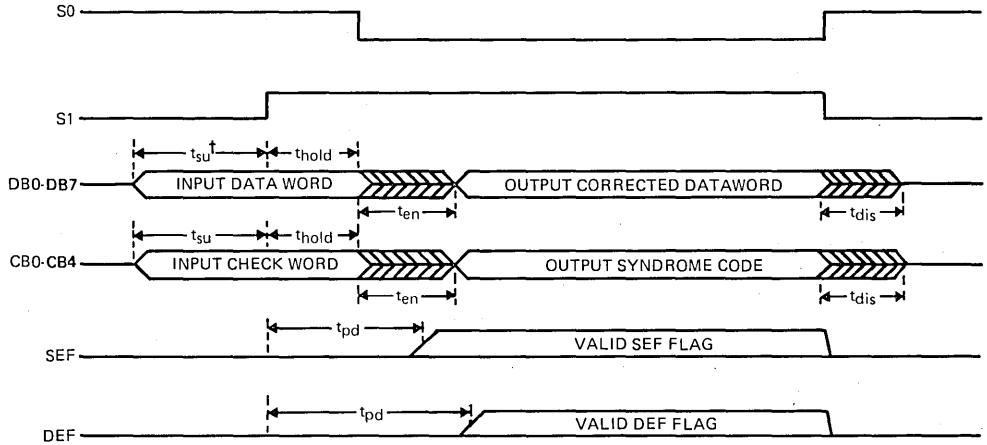

† NOTE: There are two conditions specified for t_{su} of Data or Checkword before S1†. See recommended operating conditions for detail.



TTL DEVICES

TYPES SN54LS638, SN54LS639, SN74LS638, SN74LS639 OCTAL BUS TRANSCEIVERS

D2636, JANUARY 1981 — REVISED DECEMBER 1983

- Bidirectional Bus Transceivers in High-Density 20-Pin Packages
- Hysteresis at Bus Inputs Improves Noise Margins
- Choice of True or Inverting Logic
- A Bus Outputs are Open-Collector, B Bus Outputs are 3-State

description

These octal bus transceivers are designed for asynchronous two-way communication between open-collector and 3-state buses. The devices transmit data from the A bus (open-collector) to the B bus (3-state) or from the B bus to the A bus depending upon the level at the direction control (DIR) input. The enable input (\bar{G}) can be used to disable the device so the buses are isolated.

FUNCTION TABLE

CONTROL INPUTS		OPERATION	
\bar{G}	DIR	'LS638	'LS639
L	L	\bar{B} data to A bus	B data to A bus
L	H	\bar{A} data to B bus	A data to B bus
H	X	Isolation	Isolation

H = high level, L = low level, X = irrelevant

DEVICE	A OUTPUT	B OUTPUT	LOGIC
'LS638	Open-Collector	3-State	Inverting
'LS639	Open-Collector	3-State	True

SN54LS638, SN54LS639 ... J PACKAGE
SN74LS638, SN74LS639 ... DW, J OR N PACKAGE
(TOP VIEW)

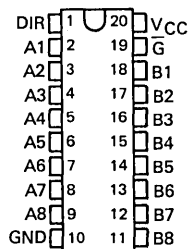

SN54LS638, SN54LS639 ... FK PACKAGE
SN74LS638, SN74LS639 ... FN PACKAGE
(TOP VIEW)

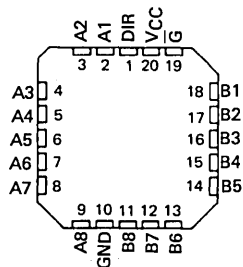

schematics of inputs and outputs

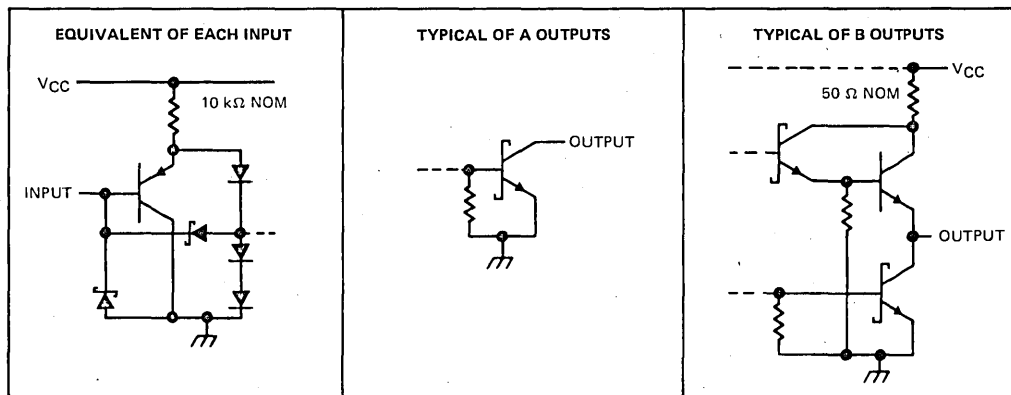

PRODUCTION DATA

This document contains information current as of publication date. Products conform to specifications per the terms of Texas Instruments standard warranty. Production processing does not necessarily include testing of all parameters.

TEXAS
INSTRUMENTS

POST OFFICE BOX 225012 • DALLAS, TEXAS 75265

3-1229

TTL DEVICES

TYPES SN54LS638, SN54LS639, SN74LS638, SN74LS639 OCTAL BUS TRANSCEIVERS

logic symbols

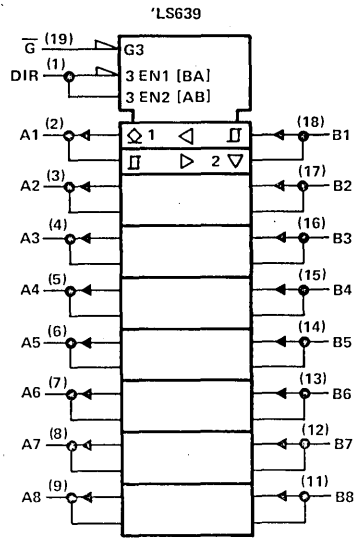
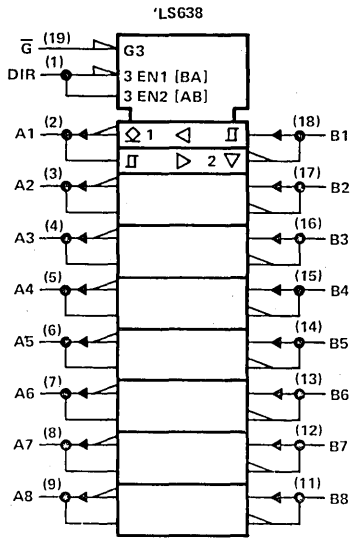

Pin numbers shown on logic notation are for DW, J or N packages.

logic diagrams (positive logic)

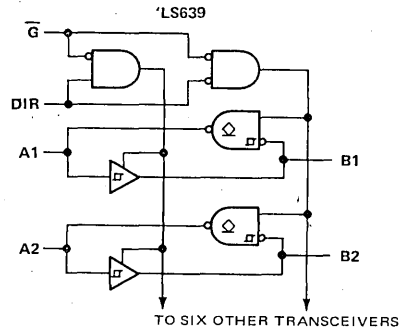
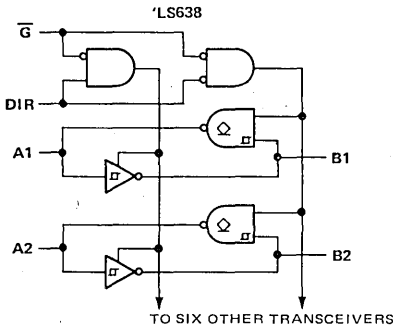

absolute maximum ratings over operating free-air temperature range (unless otherwise noted)

Supply voltage, V_{CC} (see Note 1)	7 V
Input voltage (DIR or \bar{G})	7 V
Off-state output voltage (A or B)	5.5 V
Operating free-air temperature range: SN54LS638, SN54LS639	-55°C to 125°C
SN74LS638, SN74LS639	0°C to 70°C
Storage temperature range	-65°C to 150°C

NOTE 1: Voltage values are with respect to the network ground terminal.

TYPES SN54LS638, SN54LS639, SN74LS638, SN74LS639 OCTAL BUS TRANSCEIVERS

recommended operating conditions

	SN54LS'			SN74LS'			UNIT
	MIN	NOM	MAX	MIN	NOM	MAX	
Supply voltage, V_{CC}	4.5	5	5.5	4.75	5	5.25	V
High-level output voltage, V_{OH} (A bus)	5.5			5.5			V
High-level output current, I_{OH} (B bus)	-12			-15			mA
Low-level output current, I_{OL} (A or B bus)	12			24			mA
Operating free-air temperature, T_A	-55		125	0		70	°C

electrical characteristics over recommended operating free-air temperature range (unless otherwise noted)

PARAMETER		TEST CONDITIONS†	SN54LS'			SN74LS'			UNIT
			MIN	TYP‡	MAX	MIN	TYP‡	MAX	
V_{IH}	High-level input voltage		2			2			V
V_{IL}	Low-level input voltage		0.5			0.6			V
V_{IK}	Input clamp voltage	$V_{CC} = \text{MIN}, I_I = -18 \text{ mA}$	-1.5			-1.5			V
Hysteresis ($V_{T+} - V_{T-}$)		$V_{CC} = \text{MIN}$	0.1	0.4		0.2	0.4		V
I_{OH}	High-level output current	A $V_{CC} = \text{MIN}, V_{IH} = 2 \text{ V}, V_{IL} = \text{MAX}, V_{OH} = 5.5 \text{ V}$	0.1			0.1			mA
V_{OH}	High-level output voltage	B $V_{CC} = \text{MIN}, V_{IH} = 2 \text{ V}, V_{IL} = \text{MAX}$	$I_{OH} = -3 \text{ mA}$ 2.4			2.4			V
			$I_{OH} = \text{MAX}$ 2			2			V
V_{OL}	Low-level output voltage	A or B $V_{CC} = \text{MIN}, V_{IH} = 2 \text{ V}, V_{IL} = \text{MAX}$	$I_{OL} = 12 \text{ mA}$ 0.25	0.4		0.25	0.4		V
			$I_{OL} = 24 \text{ mA}$			0.35	0.5		V
I_{OZH}	Off-state output current, high-level voltage applied	B $V_{CC} = \text{MAX}, \bar{G} \text{ at } 2 \text{ V}, V_O = 2.7 \text{ V}$	20			20			µA
I_{OZL}	Off-state output current, low-level voltage applied	A or B $V_{CC} = \text{MAX}, \bar{G} \text{ at } 2 \text{ V}, V_O = 0.4 \text{ V}$	-0.4			-0.4			mA
I_I	Input current at maximum input voltage	A or B DIR or \bar{G} $V_{CC} = \text{MAX}$	$V_I = 5.5 \text{ V}$ 0.1			0.1			mA
			$V_I = 7 \text{ V}$ 0.1			0.1			mA
I_{IH}	High-level input current	$V_{CC} = \text{MAX}, V_I = 2.7 \text{ V}$	20			20			µA
I_{IL}	Low-level input current	$V_{CC} = \text{MAX}, V_I = 0.4 \text{ V}$	-0.4			-0.4			mA
I_{OS}	Short-circuit output current§	B $V_{CC} = \text{MAX}$	-40	-225		-40	-225		mA
I_{CCH}	Supply current, outputs high	$V_{CC} = \text{MAX}, \text{Outputs open}$	48	70		48	70		mA
I_{CCL}	Supply current, outputs low	$V_{CC} = \text{MAX}, \text{Outputs open}$	62	90		62	90		mA
I_{CCZ}	Supply current, outputs off	$V_{CC} = \text{MAX}, \text{Outputs open}$	64	95		64	95		mA

† For conditions shown as MIN or MAX, use the appropriate value specified under recommended operating conditions.

‡ All typical values are at $V_{CC} = 5 \text{ V}, T_A = 25^\circ \text{C}$.

§ Not more than one output should be shorted at a time, and duration of the short circuit should not exceed one second.

switching characteristics, $V_{CC} = 5 \text{ V}, T_A = 25^\circ \text{C}$, see note 2

PARAMETER	FROM (INPUT)	TO (OUTPUT)	TEST CONDITIONS	'LS638			'LS639			UNIT
				MIN	TYP	MAX	MIN	TYP	MAX	
t_{PLH}	A	B	$C_L = 45 \text{ pF}, R_L = 667 \Omega$	6	10		8	15		ns
	B	A		17	25		19	25		
t_{PHL}	A	B		8	15		11	15		ns
	B	A		14	25		16	25		
t_{PLH}	\bar{G}	A		26	40		23	40		ns
t_{PHL}	\bar{G}	A		43	60		34	50		ns
t_{PZH}	\bar{G}	B		23	40		26	40		ns
t_{PZL}	\bar{G}	B		31	40		31	40		ns
t_{PHZ}	\bar{G}	B	15	25		15	25		ns	
t_{PLZ}	\bar{G}	B	15	25		15	25		ns	

NOTE 2: See General Information Section for load circuits and voltage waveforms.

TYPES SN54LS638, SN54LS639, SN74LS638, SN74LS639
OCTAL BUS TRANSCEIVERS

TYPICAL CHARACTERISTICS

SN54LS'
INVERTING OUTPUT VOLTAGE
 vs
INPUT VOLTAGE

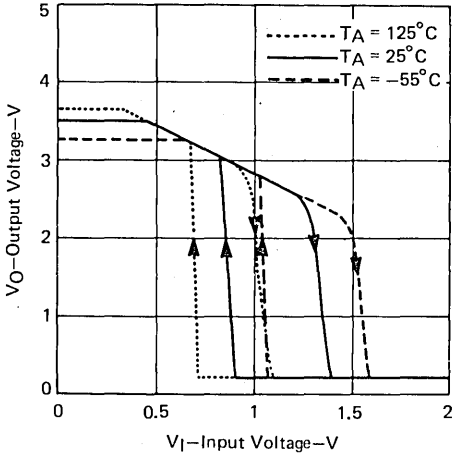

FIGURE 1

SN74LS'
INVERTING OUTPUT VOLTAGE
 vs
INPUT VOLTAGE

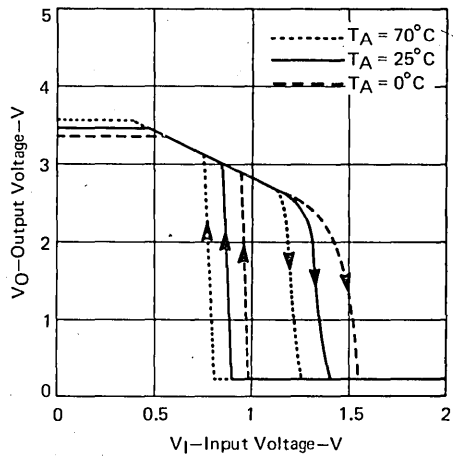

FIGURE 2

SN54LS'
NONINVERTING OUTPUT VOLTAGE
 vs
INPUT VOLTAGE

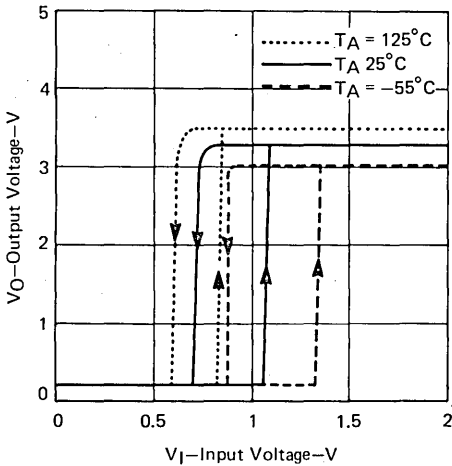

FIGURE 3

SN74LS'
NONINVERTING OUTPUT VOLTAGE
 vs
INPUT VOLTAGE

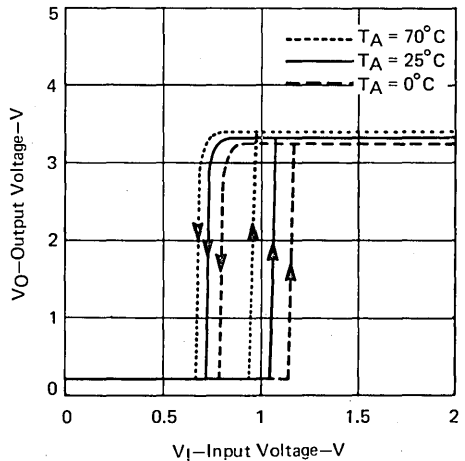

FIGURE 4

3

TTL DEVICES

TYPES SN54LS640 THRU SN54LS645, SN74LS640 THRU SN74LS645 OCTAL BUS TRANSCEIVERS

D2420, APRIL 1979—REVISED DECEMBER 1983

- SN74LS64X-1 Versions Rated at I_{OL} of 48 mA
- Bi-directional Bus Transceivers in High-Density 20-Pin Packages
- Hysteresis at Bus Inputs Improves Noise Margins
- Choice of True or Inverting Logic
- Choice of 3-State or Open-Collector Outputs

DEVICE	OUTPUT	LOGIC
'LS640	3-State	Inverting
'LS641	Open-Collector	True
'LS642	Open-Collector	Inverting
'LS643	3-State	True and inverting
'LS644	Open-Collector	True and inverting
'LS645	3-State	True

description

These octal bus transceivers are designed for asynchronous two-way communication between data buses. The devices transmit data from the A bus to the B bus or from the B bus to the A bus depending upon the level at the direction control (DIR) input. The enable input (\bar{G}) can be used to disable the device so the buses are effectively isolated.

The -1 versions of the SN74LS640 thru SN74LS645 are identical to the standard versions except that the recommended maximum I_{OL} is increased to 48 milliamperes. There are no -1 versions of the SN54LS640 thru SN54LS645.

The SN54LS640 thru SN54LS645 are characterized for operation over the full military temperature range of -55°C to 125°C. The SN74LS640 thru SN74LS645 are characterized for operation from 0°C to 70°C.

SN54LS'... J PACKAGE
SN74LS'... DW, J OR N PACKAGE
(TOP VIEW)

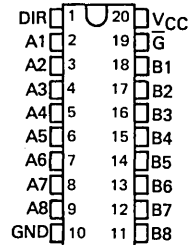

SN54LS'... FK PACKAGE
SN74LS'... FN PACKAGE
(TOP VIEW)

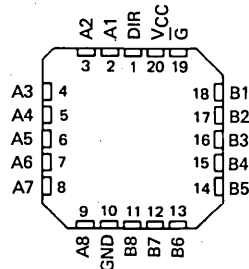

FUNCTION TABLE

CONTROL INPUTS		OPERATION		
		'LS640 'LS642	'LS641 'LS645	'LS643 'LS644
L	L	B data to A bus	B data to A bus	B data to A bus
L	H	A data to B bus	A data to B bus	\bar{A} data to B bus
H	X	Isolation	Isolation	Isolation

H = high level, L = low level, X = irrelevant

PRODUCTION DATA

This document contains information current as of publication date. Products conform to specifications per the terms of Texas Instruments standard warranty. Production processing does not necessarily include testing of all parameters.

TEXAS
INSTRUMENTS

POST OFFICE BOX 225012 • DALLAS, TEXAS 75265

3-1233

TYPES SN54LS640 THRU SN54LS645,
SN74LS640 THRU SN74LS645
OCTAL BUS TRANSCIEVERS

logic symbols

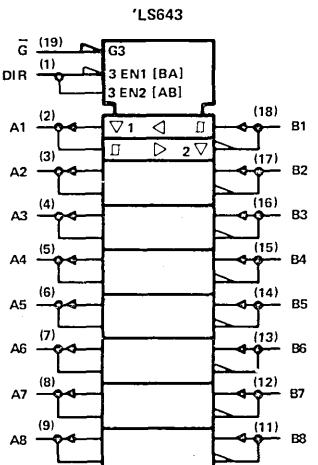
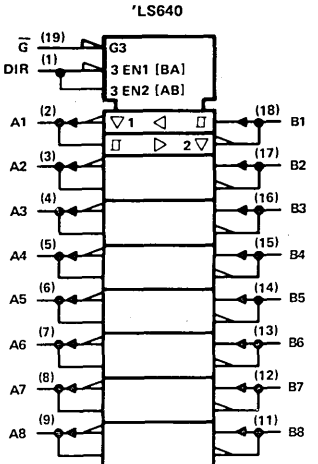
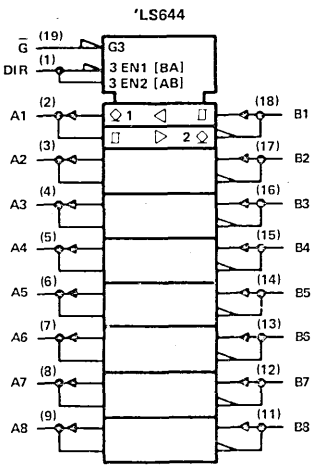
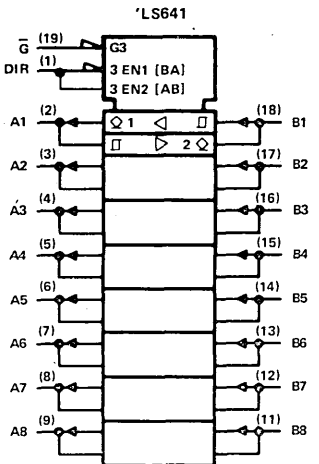
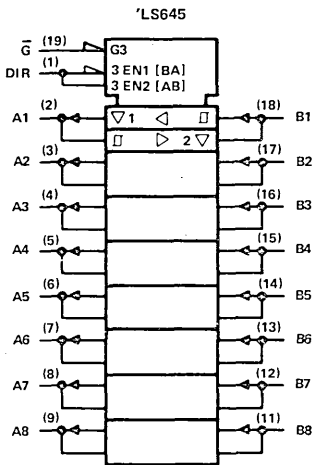
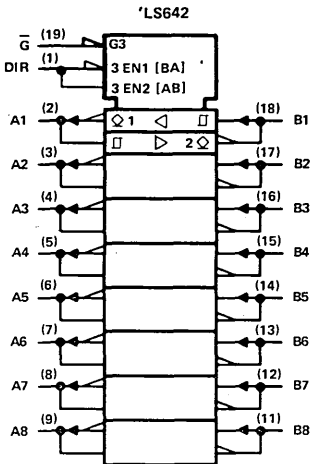

Pin numbers shown on logic notation are for DW, J or N packages.

**TYPES SN54LS640, SN54LS643, SN54LS645,
SN74LS640, SN74LS643, SN74LS645
OCTAL BUS TRANSCEIVERS WITH 3-STATE OUTPUTS**

absolute maximum ratings over operating free-air temperature range (unless otherwise noted)

Supply voltage, V_{CC} (see Note 1)	7 V
Input voltage: All inputs	7 V
I/O ports	5.5 V
Operating free-air temperature range: SN54LS640, SN54LS643, SN54LS645	-55°C to 125°C
SN74LS640, SN74LS643, SN74LS645	0°C to 70°C
Storage temperature range	-65°C to 150°C

NOTE 1: Voltage values are with respect to network ground terminal.

recommended operating conditions

PARAMETER	SN54LS640 SN54LS643 SN54LS645			SN74LS640 SN74LS643 SN74LS645			UNIT	
	MIN	NOM	MAX	MIN	NOM	MAX		
	V_{CC} Supply voltage	4.5	5	5.5	4.75	5		5.25
V_{IH} High-level input voltage	2			2			V	
V_{IL} Low-level input voltage	0.5			0.6			V	
I_{OH} High-level output current	-12			-15			mA	
I_{OL} Low-level output current	12			24			mA	
				48§				
T_A Operating free-air temperature	-55			0			70	°C

§ The 48 mA limit applies for the SN74LS640-1, SN74LS643-1, and SN74LS645-1 only.

electrical characteristics over recommended operating free-air temperature range (unless otherwise noted)

PARAMETER	TEST CONDITIONS †	SN54LS640 SN54LS643 SN54LS645			SN74LS640 SN74LS643 SN74LS645			UNIT
		MIN	TYP‡	MAX	MIN	TYP‡	MAX	
		V_{IK}	$V_{CC} = \text{MIN}, I_I = -18 \text{ mA}$	-1.5			-1.5	
Hysteresis ($V_{T+} - V_{T-}$)	$V_{CC} = \text{MIN},$ A or B input	0.1	0.4		0.2	0.4		V
V_{OH}	$V_{CC} = \text{MIN}, V_{IH} = 2 \text{ V},$ $V_{IL} = \text{MAX}$	$I_{OH} = -3 \text{ mA}$		2.4	3.4	2.4	3.4	V
		$I_{OH} = \text{MAX}$		2		2		
V_{OL}	$V_{CC} = \text{MIN}, V_{IH} = 2 \text{ V},$ $V_{IL} = \text{MAX}$	$I_{OL} = 12 \text{ mA}$		0.25	0.4	0.25	0.4	V
		$I_{OL} = 24 \text{ mA}$				0.35	0.5	
		$I_{OL} = 48 \text{ mA} ¶$				0.4		
I_{OZH}	$V_{CC} = \text{MAX}, \bar{G}$ at 2 V, $V_O = 2.7 \text{ V}$	20			20			µA
I_{OZL}	$V_{CC} = \text{MAX}, \bar{G}$ at 2 V, $V_O = 0.4 \text{ V}$	-0.4			-0.4			mA
I_I	A or B	$V_{CC} = \text{MAX}$		0.1		0.1		mA
	DIR or \bar{G}	$V_{CC} = \text{MAX}$		0.1		0.1		
I_{IH}	$V_{CC} = \text{MAX}, V_{IH} = 2.7 \text{ V}$	20			20			µA
I_{IL}	$V_{CC} = \text{MAX}, V_{IL} = 0.4 \text{ V}$	-0.4			-0.4			mA
$I_{OS} §$	$V_{CC} = \text{MAX}$	-40	-225	-40	-225	-40	-225	mA
I_{CC}	Outputs high	$V_{CC} = \text{MAX},$ Outputs open		48	70	48	70	mA
	Outputs low			62	90	62	90	
	Outputs at Hi-Z			64	95	64	95	

† For conditions shown as MIN or MAX, use the appropriate value specified under recommended operating conditions.

‡ All typical values are at $V_{CC} = 5 \text{ V}, T_A = 25^\circ\text{C}$.

§ Not more than one output should be shorted at a time, and duration of the short-circuit should not exceed one second.

¶ The 48 mA condition applies for the SN74LS640-1, SN74LS643-1, and SN74LS645-1 only.

switching characteristics at $V_{CC} = 5\text{ V}$, $T_A = 25^\circ\text{C}$

PARAMETER	FROM (INPUT)	TO (OUTPUT)	TEST CONDITIONS	'LS640, 'LS640-1			'LS643, 'LS643-1			'LS645, 'LS645-1			UNIT
				MIN	TYP	MAX	MIN	TYP	MAX	MIN	TYP	MAX	
t_{PLH} Propagation delay time, low-to-high-level output	A	B	$C_L = 45\text{ pF}$, $R_L = 667\ \Omega$, See Note 2	6	10		6	10		8	15	ns	
	B	A		6	10		8	15		8	15		
t_{PHL} Propagation delay time, high-to-low-level output	A	B		8	15		9	15		11	15	ns	
	B	A		8	15		11	15		11	15		
t_{PZL} Output enable time to low level	\overline{G}	A	31	40		32	45		31	40	ns		
	\overline{G}	B	31	40		32	45		31	40			
t_{PZH} Output enable time to high level	\overline{G}	A	23	40		27	40		26	40	ns		
	\overline{G}	B	23	40		23	40		26	40			
t_{PLZ} Output disable time from low level	\overline{G}	A	15	25		15	25		15	25	ns		
	\overline{G}	B	15	25		15	25		15	25			
t_{PHZ} Output disable time from high level	\overline{G}	A	15	25		15	25		15	25	ns		
	\overline{G}	B	15	25		15	25		15	25			

NOTE 2: See General Information Section for load circuits and voltage waveforms.

schematics of inputs and outputs

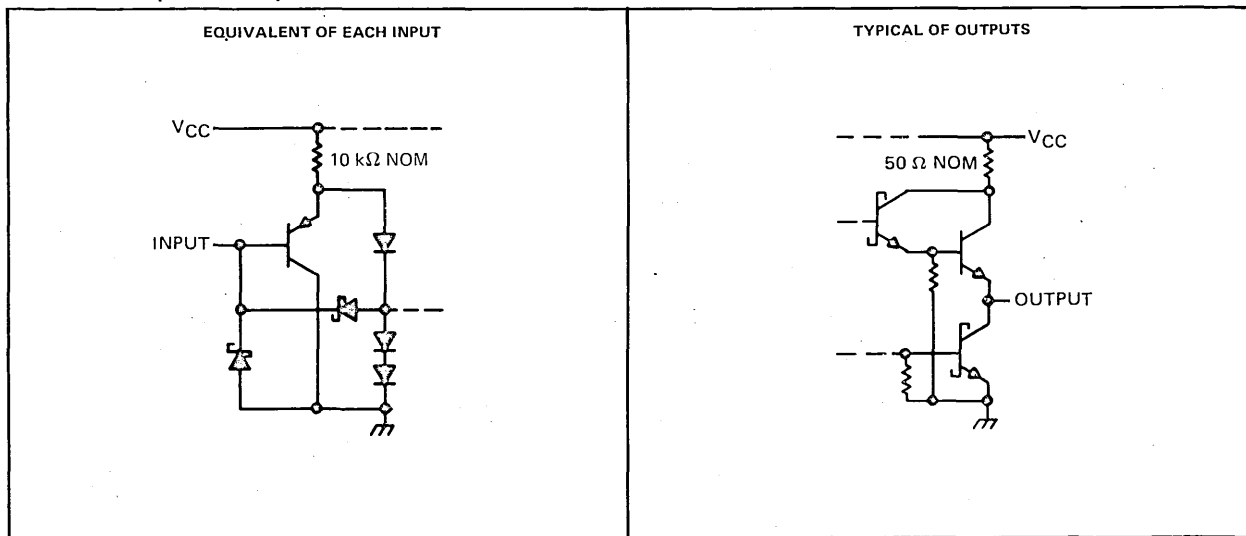

TTL DEVICES



TYPES SN54LS640, SN54LS643, SN54LS645,
SN74LS640, SN74LS643, SN74LS645
OCTAL BUS TRANSCEIVERS WITH 3-STATE OUTPUTS

**TYPES SN54LS640, SN54LS643, SN54LS645,
SN74LS640, SN74LS643, SN74LS645
OCTAL BUS TRANSCEIVERS WITH 3-STATE OUTPUTS**

TYPICAL CHARACTERISTICS

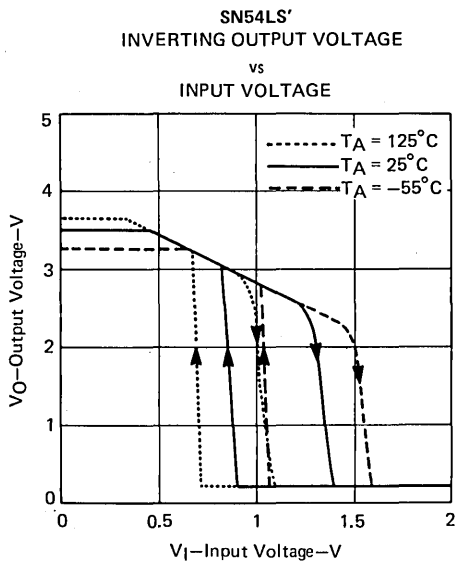

FIGURE 1

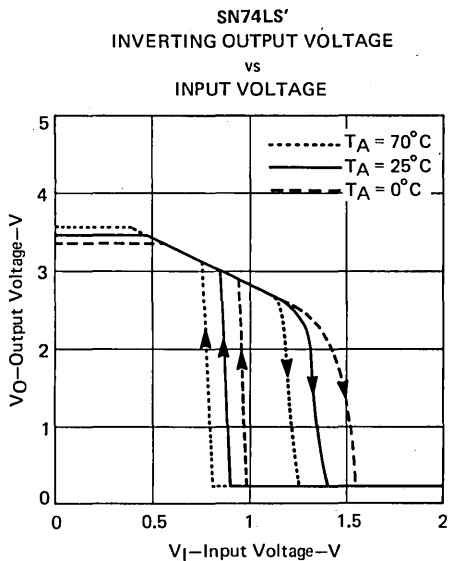

FIGURE 2

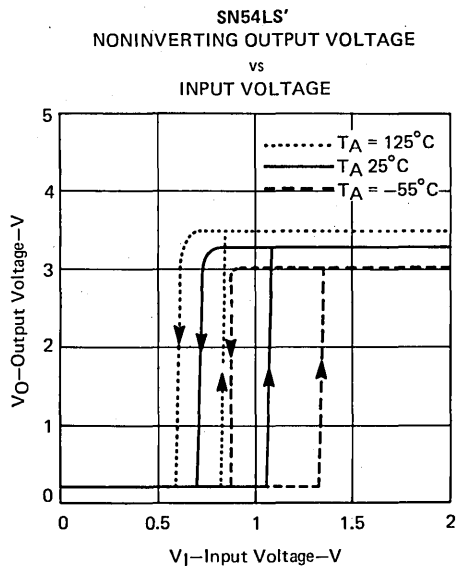

FIGURE 3

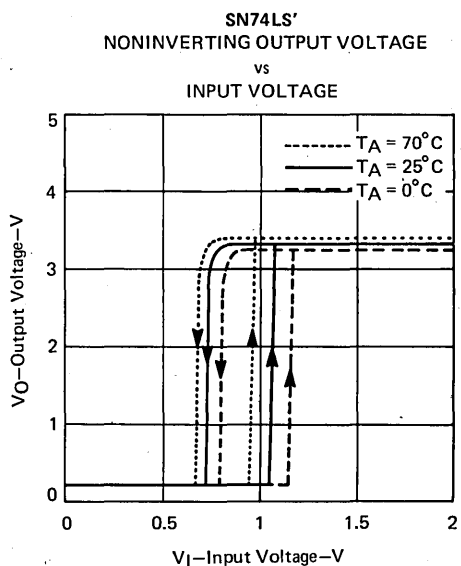

FIGURE 4

3

TTL DEVICES

TYPES SN54LS641, SN54LS642, SN54LS644, SN74LS641, SN74LS642, SN74LS644 OCTAL BUS TRANSCEIVERS WITH OPEN-COLLECTOR OUTPUTS

absolute maximum ratings over operating free-air temperature range (unless otherwise noted)

Supply voltage, V_{CC} (see Note 1)	7 V
Input voltage: All inputs and I/O ports	7 V
Operating free-air temperature range: SN54LS641, SN54LS642, SN54LS644	-55°C to 125°C
SN74LS641, SN74LS642, SN74LS644	0°C to 70°C
Storage temperature range	-65°C to 150°C

NOTE 1: Voltage values are with respect to network ground terminal.

recommended operating conditions

PARAMETER	SN54LS641 SN54LS642 SN54LS644			SN74LS641 SN74LS642 SN74LS644			UNIT
	MIN	NOM	MAX	MIN	NOM	MAX	
V_{CC} Supply voltage	4.5	5	5.5	4.75	5	5.25	V
V_{IH} High-level input voltage	2			2			V
V_{IL} Low-level input voltage	0.5			0.6			V
V_{OH} High-level output voltage	5.5			5.5			V
I_{OL} Low-level output current	12			24			mA
				48 §			
T_A Operating free-air temperature	-55 125			0 70			°C

§ The 48 mA limit applies for the SN74LS641-1, SN74LS642-1, and SN74LS644-1 only.

electrical characteristics over recommended operating free-air temperature range (unless otherwise noted)

PARAMETER		TEST CONDITIONS†	SN54LS641 SN54LS642 SN54LS644			SN74LS641 SN74LS642 SN74LS644			UNIT
			MIN	TYP‡	MAX	MIN	TYP‡	MAX	
V_{IK}		$V_{CC} = \text{MIN}, I_I = -18 \text{ mA}$	-1.5			-1.5			V
Hysteresis ($V_{T+} - V_{T-}$)		$V_{CC} = \text{MIN},$ A or B input	0.1	0.4		0.2	0.4		V
I_{OH}		$V_{CC} = \text{MIN},$ $V_{IL} = \text{MAX},$ $V_{IH} = 2 \text{ V},$ $V_{OH} = 5.5 \text{ V}$	0.1			0.1			mA
V_{OL}		$V_{CC} = \text{MIN},$ $V_{IH} = 2 \text{ V},$ $V_{IL} = \text{MAX}$	0.25 0.4			0.25 0.4			V
		$I_{OL} = 12 \text{ mA}$				0.35 0.5			
		$I_{OL} = 24 \text{ mA}$ $I_{OL} = 48 \text{ mA} §$				0.4 0.5			
I_I	A or B	$V_{CC} = \text{MAX}$	0.1			0.1			mA
	DIR or \bar{G}		0.1			0.1			
I_{IH}		$V_{CC} = \text{MAX},$ $V_I = 2.7 \text{ V}$	20			20			μA
I_{IL}		$V_{CC} = \text{MAX},$ $V_I = 0.4 \text{ V}$	-0.4			-0.4			mA
I_{CC}	Outputs high	$V_{CC} = \text{MAX},$ Outputs open	48 70			48 70			mA
	Outputs low		62 90			62 90			
	Outputs at Hi-Z		64 95			64 95			

† For conditions shown as MIN or MAX, use the appropriate value specified under recommended operating conditions.

‡ All typical values are at $V_{CC} = 5 \text{ V}, T_A = 25^\circ\text{C}$.

§ The 48 mA condition applies for the SN74LS641-1, SN74LS642-1, and SN74LS644-1 only.



TTL DEVICES



switching characteristics at $V_{CC} = 5\text{ V}$, $T_A = 25^\circ\text{C}$

PARAMETER	FROM (INPUT)	TO (OUTPUT)	TEST CONDITIONS	'LS641, 'LS641-1			'LS642, 'LS642-1			'LS644, 'LS644-1			UNIT
				MIN	TYP	MAX	MIN	TYP	MAX	MIN	TYP	MAX	
t_{PLH} Propagation delay time, low-to-high-level output	A	B	$C_L = 45\text{ pF}$, $R_L = 667\ \Omega$, See Note 2	17	25		19	25		17	25	ns	
	B	A		17	25		19	25		19	25		
t_{PHL} Propagation delay time, high-to-low-level output	A	B		16	25		14	25		14	25	ns	
	B	A		16	25		14	25		16	25		
t_{PLH} Output disable time from low level	\bar{G} , DIR	A		23	40		26	40		26	40	ns	
	\bar{G} , DIR	B		25	40		28	40		25	40		
t_{PHL} Output enable time from high level	\bar{G} , DIR	A	34	50		43	60		43	60	ns		
	\bar{G} , DIR	B	37	50		39	60		37	50			

NOTE 2: See General Information Section for load circuits and voltage waveforms.

schematics of inputs and outputs

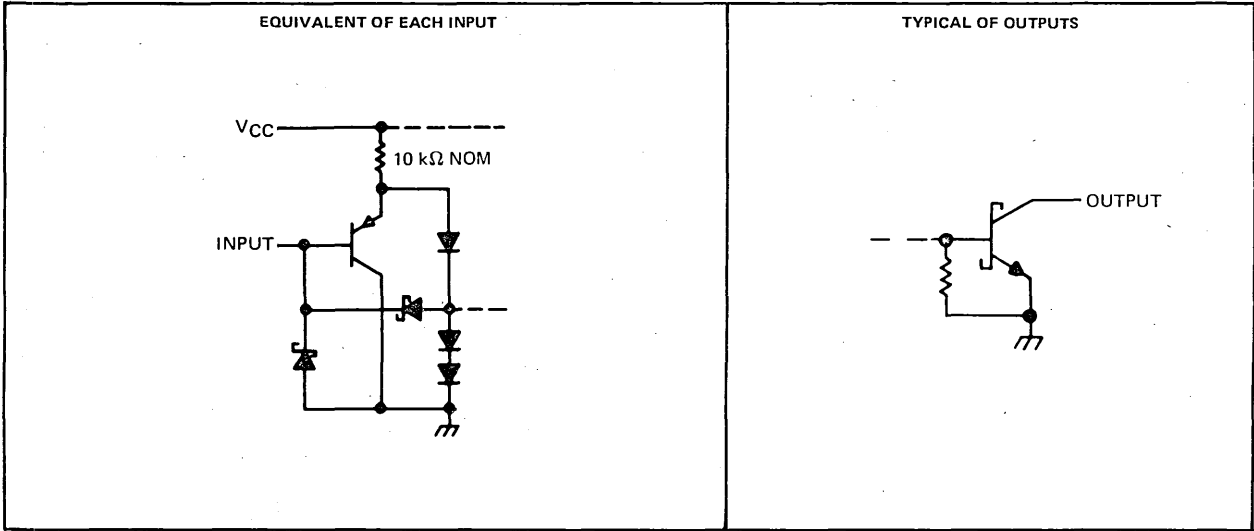

TYPES SN54LS641, SN54LS642, SN54LS644
 SN74LS641, SN74LS642, SN74LS644
 OCTAL BUS TRANSCIEVERS WITH OPEN-COLLECTOR OUTPUTS

TYPES SN54LS646 THRU SN54LS649 SN74LS646 THRU SN74LS649 OCTAL BUS TRANSCEIVERS AND REGISTERS

D2661, DECEMBER 1982 — REVISED DECEMBER 1983

- Independent Registers for A and B Buses
- Multiplexed Real-Time and Stored Data
- Choice of True or Inverting Data Paths
- Choice of 3-State or Open-Collector Outputs
- Included Among the Package Options Are Compact 24-pin 300-mil Wide DIPs and Both 28-pin Plastic and Ceramic Chip Carriers
- Dependable Texas Instruments Quality and Reliability

DEVICE	OUTPUT	LOGIC
'LS646	3-State	True
'LS647	Open-Collector	True
'LS648	3-State	Inverting
'LS649	Open-Collector	Inverting

description

These devices consist of bus transceiver circuits with 3-state or open-collector outputs, D-type flip-flops, and control circuitry arranged for multiplexed transmission of data directly from the input bus or from the internal registers. Data on the A or B bus will be clocked into the registers on the low-to-high transition of the appropriate clock pin (CAB or CBA). The following examples demonstrate the four fundamental bus-management functions that can be performed with the octal bus transceivers and registers.

SN54LS' ... JT PACKAGE
SN74LS' ... DW, JT OR NT PACKAGE
(TOP VIEW)

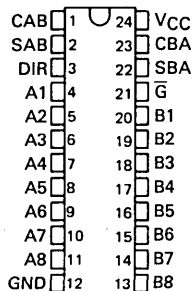

SN54LS' ... FK PACKAGE
SN74LS' ... FN PACKAGE
(TOP VIEW)

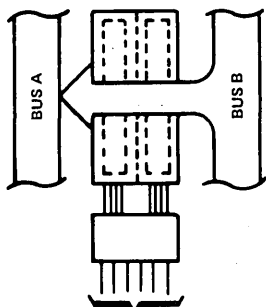
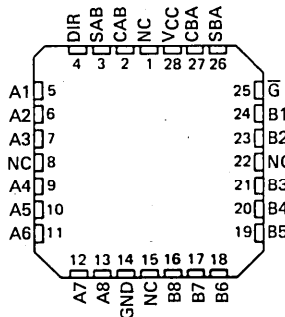

(21)	(3)	(1)	(23)	(2)	(22)
\bar{G}	DIR	CAB	CBA	SAB	SBA
L	L	X	H or L	X	L

REAL-TIME TRANSFER
BUS B TO BUS A

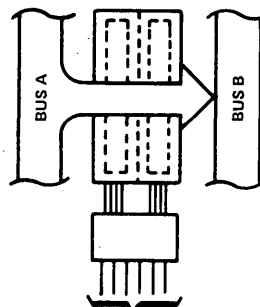

(21)	(3)	(1)	(23)	(2)	(22)
\bar{G}	DIR	CAB	CBA	SAB	SBA
L	H	H or L	X	L	X

REAL-TIME TRANSFER
BUS A TO BUS B

PRODUCTION DATA
This document contains information current as of publication date. Products conform to specifications per the terms of Texas Instruments standard warranty. Production processing does not necessarily include testing of all parameters.

**TEXAS
INSTRUMENTS**

POST OFFICE BOX 225012 • DALLAS, TEXAS 75265

3-1241

TYPES SN54LS646 THRU SN54LS649, SN74LS646 THRU SN74LS649 OCTAL BUS TRANSCEIVERS AND REGISTERS

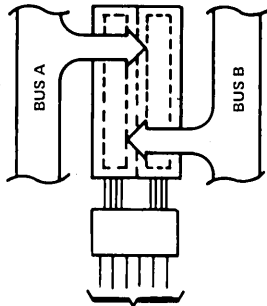

(21)	(3)	(1)	(23)	(2)	(22)
\bar{G}	DIR	CAB	CBA	SAB	SBA
X	X	↑	X	X	X
X	X	X	↑	X	X
H	X	↑	↑	X	X

STORAGE FROM
A, B, OR A AND B

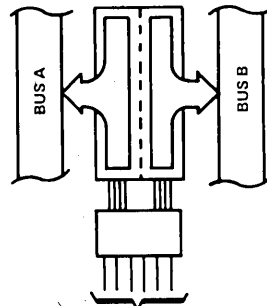

(21)	(3)	(1)	(23)	(2)	(22)
\bar{G}	DIR	CAB	CBA	SAB	SBA
L	L	X	X	X	H
L	H	X	X	H	X

TRANSFER
STORED DATA
TO A OR B

Enable (\bar{G}) and direction (DIR) pins are provided to control the transceiver functions. In the transceiver mode, data present at the high-impedance port may be stored in either register or in both. The select controls (SAB and SBA) can multiplex stored and real-time (transparent mode) data. The direction control determines which bus will receive data when enable \bar{G} is active (low). In the isolation mode (control \bar{G} high), A data may be stored in one register and/or B data may be stored in the other register.

When an output function is disabled, the input function is still enabled and may be used to store and transmit data. Only one of the two buses, A or B, may be driven at a time.

The SN54' family is characterized for operation over the full military temperature range of -55°C to 125°C . The SN74' family is characterized for operation from 0° to 70°C .

FUNCTION TABLE

INPUTS						DATA I/O [†]		OPERATION OR FUNCTION	
\bar{G}	DIR	CAB	CBA	SAB	SBA	A1 THRU A8	B1 THRU B8	LS646, LS647	LS648, LS649
X	X	↑	X	X	X	Input	Not specified	Store A, B unspecified	Store A, B unspecified
X	X	X	↑	X	X	Not specified	Input	Store B, A unspecified	Store B, A unspecified
H	X	↑	↑	X	X	Input	Input	Store A and B Data	Store A and B Data
H	X	H or L	H or L	X	X			Isolation, hold storage	Isolation, hold storage
L	L	X	H or L	X	L	Output	Input	Real-Time B Data to A Bus	Real-Time \bar{B} Data to A Bus
L	L	X	X	X	H			Stored B Data to A Bus	Stored \bar{B} Data to A Bus
L	H	H or L	X	L	X	Input	Output	Real-Time A Data to B Bus	Real-Time \bar{A} Data to B Bus
L	H	X	X	H	X			Stored A Data to B Bus	Stored \bar{A} Data to B Bus

[†] The data output functions may be enabled or disabled by various signals at the \bar{G} and DIR inputs. Data input functions are always enabled, i.e., data at the bus pins will be stored on every low-to-high transition on the clock inputs.



TYPES SN54LS646 THRU SN54LS649, SN74LS646 THRU SN74LS649 OCTAL BUS TRANSCEIVERS AND REGISTERS

logic diagrams (positive logic)

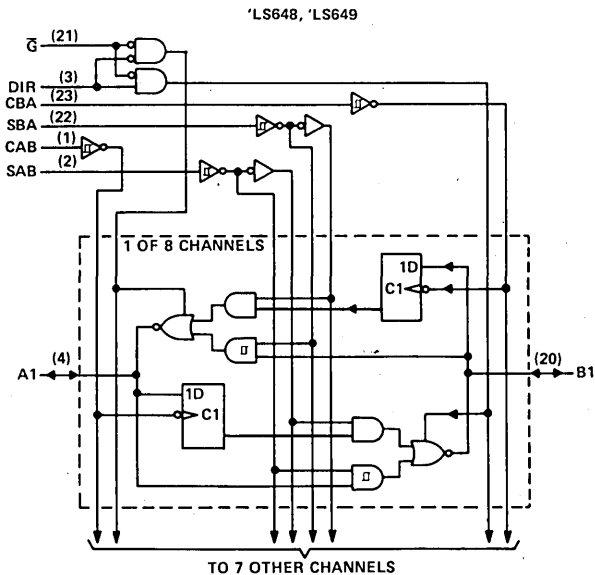
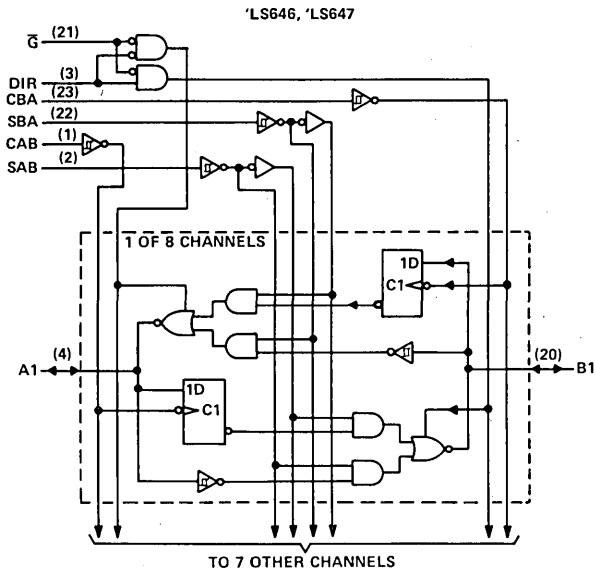

Pin numbers shown on logic notation are for DW or NT packages.



TTL DEVICES

**TYPES SN54LS646 THRU SN54LS649,
SN74LS646 THRU SN74LS649
OCTAL BUS TRANSCEIVERS AND REGISTERS**

schematics of inputs and outputs

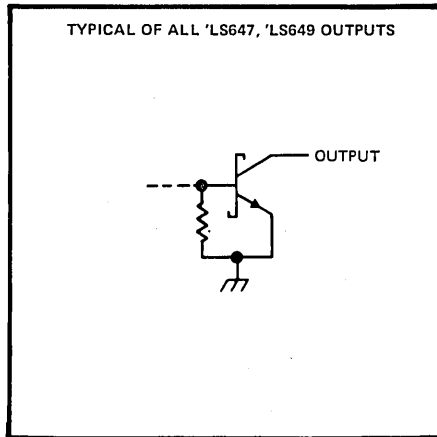
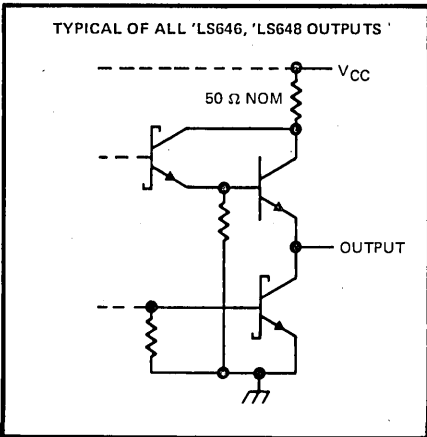
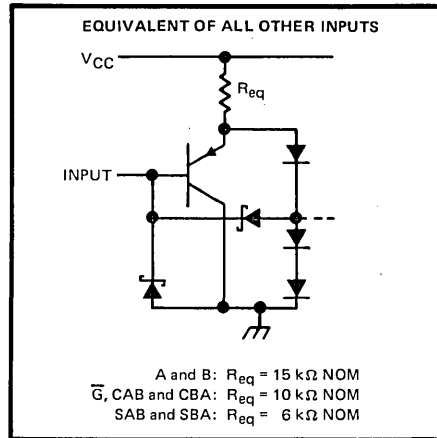
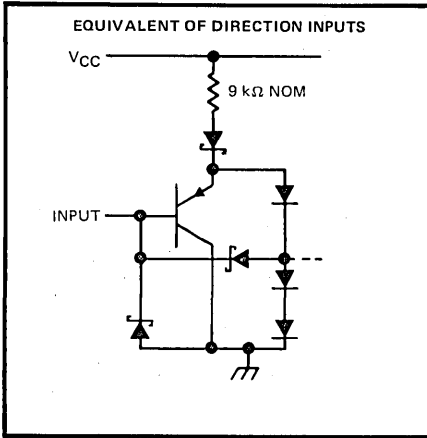

TTL DEVICES

TYPES SN54LS646, SN54LS647, SN74LS646, SN74LS647 OCTAL BUS TRANSCEIVERS AND REGISTERS

logic symbols

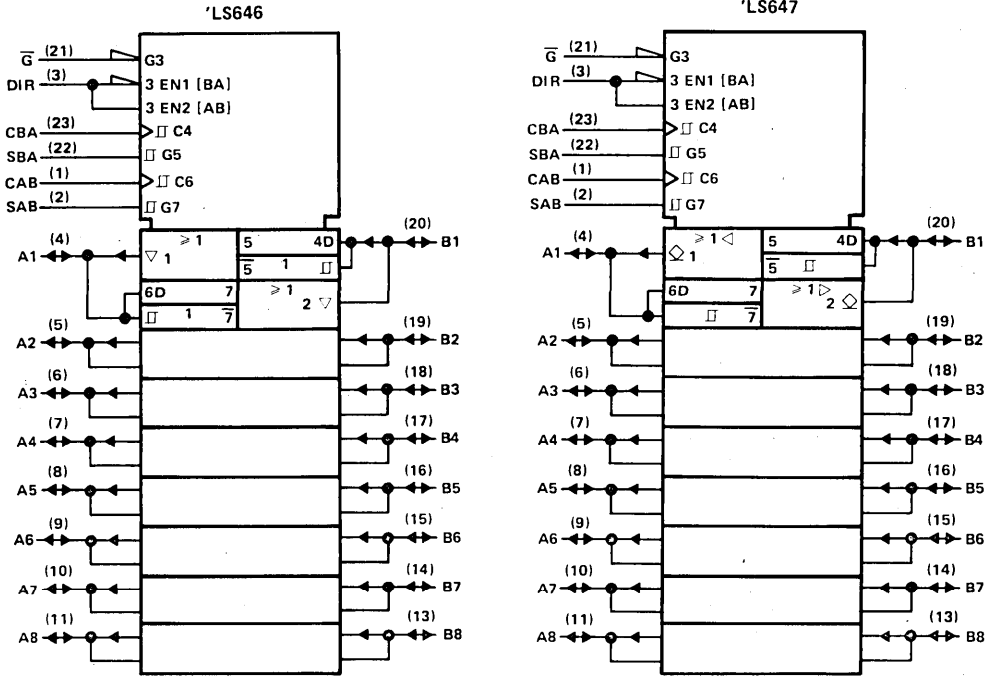

Pin numbers shown on logic notation are for DW or NT packages.

TTL DEVICES

TYPES SN54LS648, SN54LS649, SN74LS648, SN74LS649
OCTAL BUS TRANSCEIVERS AND REGISTERS

logic symbols (continued)

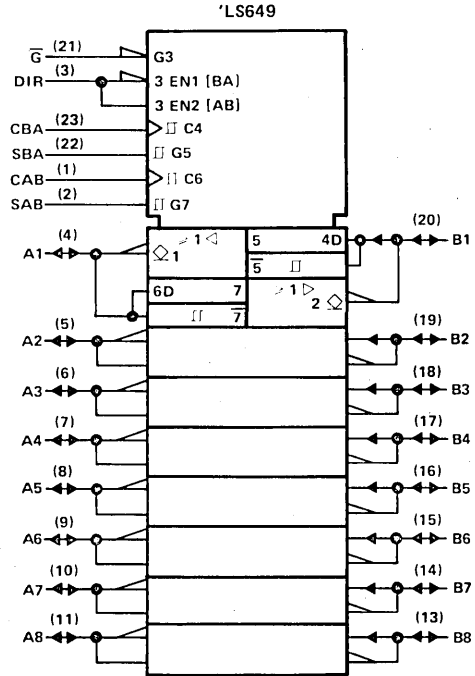
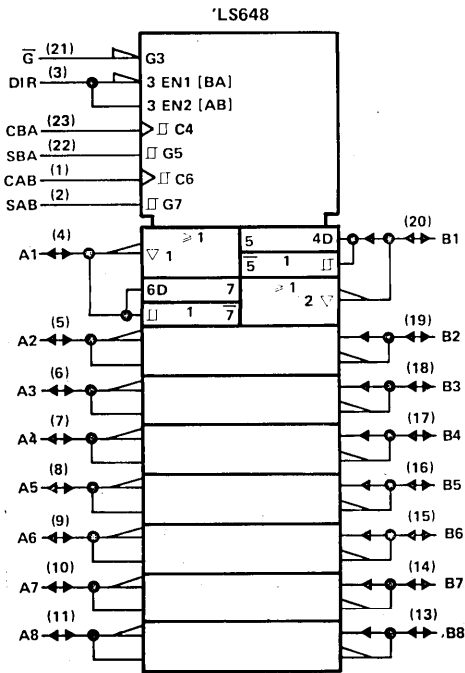

Pin numbers shown on logic notation are for DW or NT packages.

3 TTL DEVICES

TYPES SN54LS646, SN54LS648, SN74LS646, SN74LS648

OCTAL BUS TRANSCEIVERS AND REGISTERS WITH 3-STATE OUTPUTS

switching characteristics, $V_{CC} = 5\text{ V}$, $T_A = 25^\circ\text{C}$

PARAMETER	FROM (INPUT)	TO (OUTPUT)	TEST CONDITIONS	'LS646			'LS648			UNIT
				MIN	TYP	MAX	MIN	TYP	MAX	
t_{PLH}	CAB or CBA	A or B	$R_L = 667\ \Omega$, $C_L = 45\ \text{pF}$, See Note 2	15	25		15	25	ns	
t_{PHL}				23	35	24	40	ns		
t_{PLH}	A or B	B or A		12	18		12	18	ns	
t_{PHL}				13	20	15	25	ns		
t_{PLH}	SAB or SBA† with Bus input high	A or B		26	40		37	55	ns	
t_{PHL}				21	35	24	40	ns		
t_{PLH}	SAB or SBA† with Bus input low	A or B		33	50		26	40	ns	
t_{PHL}				14	25	23	40	ns		
t_{PZH}	\bar{G}	A or B		33	55		30	50	ns	
t_{PZL}				42	65	37	55	ns		
t_{PZH}	DIR	A or B		28	45		23	40	ns	
t_{PZL}				39	60	30	45	ns		
t_{PHZ}	\bar{G}	A or B		23	35		28	45	ns	
t_{PLZ}				22	35	22	35	ns		
t_{PHZ}	DIR	A or B		20	30		24	35	ns	
t_{PLZ}				19	30	19	30	ns		

t_{PLH} = propagation delay time, low-to-high-level output

t_{PHL} = propagation delay time, high-to-low-level output

t_{PZH} = output enable time to high level

t_{PZL} = output enable time to low level

t_{PHZ} = output disable time from high level

t_{PLZ} = output disable time from low level

† These parameters are measured with the internal output state of the storage register opposite to that of the bus input.

NOTE 2: See General Information Section for load circuits and voltage waveforms.

3

TTL DEVICES

TYPES SN54LS647, SN54LS649, SN74LS647, SN74LS649 OCTAL BUS TRANSCEIVERS AND REGISTERS WITH OPEN-COLLECTOR OUTPUTS

absolute maximum ratings over operating free-air temperature range (unless otherwise noted)

Supply voltage, V_{CC} (see Note 1)	7 V
Input voltage (control inputs)	7 V
Off-state output voltage (A and B ports)	5.5 V
Operating free-air temperature range: SN54LS647, SN54LS649	-55°C to 125°C
SN74LS647, SN74LS649	-0°C to 70°C
Storage temperature range	-65°C to 150°C

recommended operating conditions

		SN54LS647 SN54LS649			SN74LS647 SN74LS649			UNIT
		MIN	NOM	MAX	MIN	NOM	MAX	
V_{CC}	Supply voltage	4.5	5	5.5	4.75	5	5.25	V
V_{IH}	High-level input voltage	2			2			V
V_{IL}	Low-level input voltage			0.5			0.6	V
V_{OH}	High-level output voltage			5.5			5.5	V
I_{OL}	Low-level output voltage			12			24	mA
t_w	Pulse duration	CBA or CAB high		15	15			ns
		CBA or CAB low		30	30			
		Data high or low		30	30			
t_{su}	Setup time before CAB↑ or CBA↑	A or B		15	15		ns	
t_h	Hold time after CAB↑ or CBA↑	A or B		0	0		ns	
T_A	Operating free-air temperature	-55		125	0		70	°C

electrical characteristics over recommended operating free-air temperature range (unless otherwise noted)

PARAMETER		TEST CONDITIONS†	SN54LS647 SN54LS649			SN74LS647 SN74LS649			UNIT	
			MIN	TYP‡	MAX	MIN	TYP‡	MAX		
V_{IK}		$V_{CC} = \text{MIN}, I_I = -18 \text{ mA}$			-1.5			-1.5	V	
Hysteresis ($V_{T+} - V_{T-}$)		A or B input $V_{CC} = \text{MIN}$	0.1	0.4		0.2	0.4		V	
I_{OH}		$V_{CC} = \text{MIN}, V_{IH} = 2 \text{ V}, V_{IL} = \text{MAX}, V_{OH} = 5.5 \text{ V}$			0.1			0.1	mA	
V_{OL}		$V_{CC} = \text{MIN}, V_{IH} = 2 \text{ V}, V_{IL} = \text{MAX}, I_{OL} = 12 \text{ mA}, I_{OL} = 24 \text{ mA}$	0.25	0.4		0.25	0.4	0.35	0.5	V
I_I	A or B	$V_{CC} = \text{MAX}$			0.1			0.1	mA	
	All others				0.1			0.1		
I_{IH}		$V_{CC} = \text{MAX}, V_I = 2.7 \text{ V}$			20			20	μA	
I_{IL}		$V_{CC} = \text{MAX}, V_I = 0.4 \text{ V}$			-0.4			-0.4	mA	
I_{CC}	'LS647	$V_{CC} = \text{MAX}, \text{Outputs open}$	Outputs high	79	130	79	130	mA		
			Outputs low	94	150	94	150			
	'LS649	$V_{CC} = \text{MAX}, \text{Outputs open}$	Outputs high	79	130	79	130			
			Outputs low	94	150	94	150			

† For conditions shown as MIN or MAX, use the appropriate value specified under recommended operating conditions.

‡ All typical values are at $V_{CC} = 5 \text{ V}, T_A = 25^\circ\text{C}$.



TTL DEVICES

TYPES SN54LS647, SN54LS649, SN74LS647, SN74LS649

OCTAL BUS TRANSCEIVERS AND REGISTERS WITH OPEN-COLLECTOR OUTPUTS

switching characteristics, $V_{CC} = 5\text{ V}$, $T_A = 25^\circ\text{C}$

PARAMETER	FROM (INPUT)	TO (OUTPUT)	TEST CONDITIONS	'LS647			'LS649			UNIT
				MIN	TYP	MAX	MIN	TYP	MAX	
t_{PLH}	CAB or CBA	A or B	$R_L = 667\ \Omega$, $C_L = 45\ \text{pF}$, See Note 2	22	35	17	30	ns		
t_{PHL}				28	45	28	45	ns		
t_{PLH}	A or B	B or A		17	26	15	25	ns		
t_{PHL}				18	27	20	30	ns		
t_{PLH}	SAB or SBA [†] with Bus input high	A or B		33	50	37	55	ns		
t_{PHL}				29	45	28	45	ns		
t_{PLH}	SAB or SBA [†] with Bus input low	A or B		39	60	30	45	ns		
t_{PHL}				19	30	26	40	ns		
t_{PLH}	G	A or B		25	40	21	40	ns		
t_{PHL}				33	50	34	50	ns		
t_{PLH}	DIR	A or B	23	35	19	30	ns			
t_{PHL}			25	40	27	45	ns			

t_{PLH} = propagation delay time, low-to-high-level output

t_{PHL} = propagation delay time, high-to-low-level output

[†] These parameters are measured with the internal outputs state of the storage register opposite to that of the bus input.

NOTE 2: See General Information Section for load circuits and voltage waveforms.

TYPES SN54LS651 THRU SN54LS654 SN74LS651 THRU SN74LS654 OCTAL BUS TRANSCEIVERS AND REGISTERS

D2637, JANUARY 1981 — REVISED DECEMBER 1983

- Bus Transceivers/Registers
- Independent Registers and Enables for A and B Buses
- Multiplexed Real-Time and Stored Data
- Choice of True and Inverting Data Paths
- Choice of 3-State or Open-Collector Outputs to A Bus
- Dependable Texas Instruments Quality and Reliability

DEVICE	A OUTPUT	B OUTPUT	LOGIC
LS651	3-State	3-State	Inverting
LS652	3-State	3-State	True
LS653	Open-collector	3-State	Inverting
LS654	Open-collector	3-State	True

description

These devices consist of bus transceiver circuits, D-type flip-flops, and control circuitry arranged for multiplexed transmission of data directly from the data bus or from the internal storage registers. Enable GAB and GBA are provided to control the transceiver functions. SAB and SBA control pins are provided to select whether real-time or stored data is transferred. A low input level selects real-time data, and a high selects stored data. The following examples demonstrate the four fundamental bus-management functions that can be performed with the 'LS651, 'LS652, 'LS653, and 'LS654.

SN54LS' ... JT PACKAGE
SN74LS' ... DW, JT OR NT PACKAGE
(TOP VIEW)

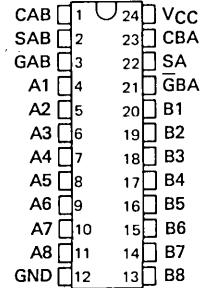

SN54LS' ... FK PACKAGE
SN74LS' ... FN PACKAGE
(TOP VIEW)

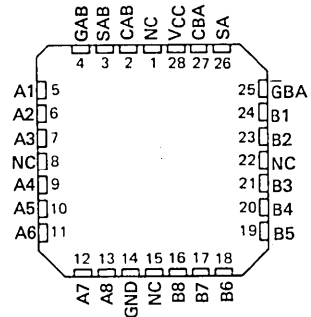

NC — No internal connection

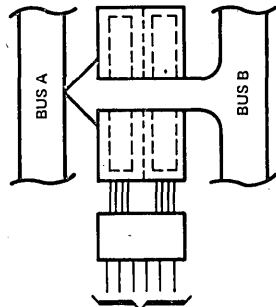

GAB \bar{G} BA CAB CBA SAB SBA
L L X X X L

REAL-TIME TRANSFER
BUS B TO BUS A

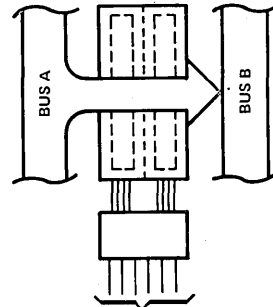

GAB \bar{G} BA CAB CBA SAB SBA
H H X X L X

REAL-TIME TRANSFER
BUS A TO BUS B

PRODUCTION DATA

This document contains information current as of publication date. Products conform to specifications per the terms of Texas Instruments standard warranty. Production processing does not necessarily include testing of all parameters.

TEXAS
INSTRUMENTS

POST OFFICE BOX 225012 • DALLAS, TEXAS 75265

TTL DEVICES

**TYPES SN54LS651 THRU SN54LS654
SN74LS651 THRU SN74LS654
OCTAL BUS TRANSCEIVERS AND REGISTERS**

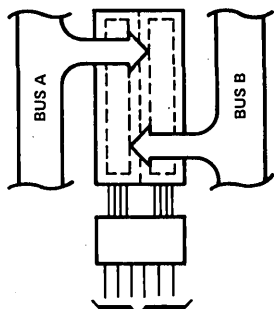

GAB	$\overline{\text{GBA}}$	CAB	CBA	SAB	SBA
X	H	↑	X	X	X
L	X	X	↑	X	X
L	H	↑	X	X	X

STORAGE FROM
A AND/OR B

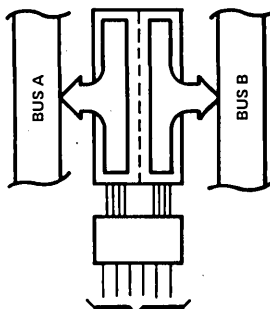

GAB	$\overline{\text{GBA}}$	CAB	CBA	SAB	SBA
H	L	H or L	H or L	H	H

TRANSFER
STORED DATA
TO A AND/OR B

Data on the A or B data bus, or both, can be stored in the internal D flip-flop by low-to-high transitions at the appropriate clock pins (CAB or CBA) regardless of the select or enable control pins. When SAB and SBA are in the real-time transfer mode, it is also possible to store data without using the internal D-type flip-flops by simultaneously enabling GAB and $\overline{\text{GBA}}$. In this configuration each output reinforces its input. Thus, when all other data sources to the two sets of bus lines are at high impedance, each set of bus lines will remain at its last state.

The SN54LS651 through SN54LS654 are characterized for operation over the full military temperature range of -55°C to 125°C . The SN74LS651 through SN74LS654 are characterized for operation from 0°C to 70°C .

FUNCTION TABLE

INPUTS					DATA I/O*		OPERATION OR FUNCTION		
GAB	$\overline{\text{GBA}}$	CAB	CBA	SAB	SBA	A1 THRU A8	B1 THRU B8	'LS651, 'LS653	'LS652, 'LS654
L	H	H or L	H or L	X	X	Input	Input	Isolation	Isolation
L	H	↑	↑	X	X	Input	Input	Store A and B Data	Store A and B Data
X	H	↑	H or L	X	X	Input	Not specified	Store A, Hold B	Store A, Hold B
H	H	↑	↑	X	X	Input	Output	Store A in both registers	Store A in both registers
L	X	H or L	↑	X	X	Not specified	Input	Hold A, Store B	Hold A, Store B
L	L	↑	↑	X	X	Output	Input	Store B in both registers	Store B in both registers
L	L	X	X	X	L	Output	Input	Real-Time $\overline{\text{B}}$ Data to A Bus	Real-Time B Data to A Bus
L	L	X	H or L	X	H	Output	Input	Stored $\overline{\text{B}}$ Data to A Bus	Stored B Data to A Bus
H	H	X	X	L	X	Input	Output	Real-Time $\overline{\text{A}}$ Data to B Bus	Real-Time A Data to B Bus
H	H	H or L	X	H	X	Input	Output	Stored $\overline{\text{A}}$ Data to B Bus	Stored A Data to B Bus
H	L	H or L	H or L	H	H	Output	Output	Stored $\overline{\text{A}}$ Data to B Bus and Stored $\overline{\text{B}}$ Data to A Bus	Stored A Data to B Bus and Stored B Data to A Bus

* The data output functions may be enabled or disabled by various signals at the GAB and $\overline{\text{GBA}}$ inputs. Data input functions are always enabled, i.e., data at the bus pins will be stored on every low-to-high transition on the clock inputs.

3

TTL DEVICES

TYPES SN54LS651 THRU SN54LS654
SN74LS651 THRU SN74LS654
OCTAL BUS TRANSCEIVERS AND REGISTERS

logic diagrams (positive logic)

'LS651, 'LS653

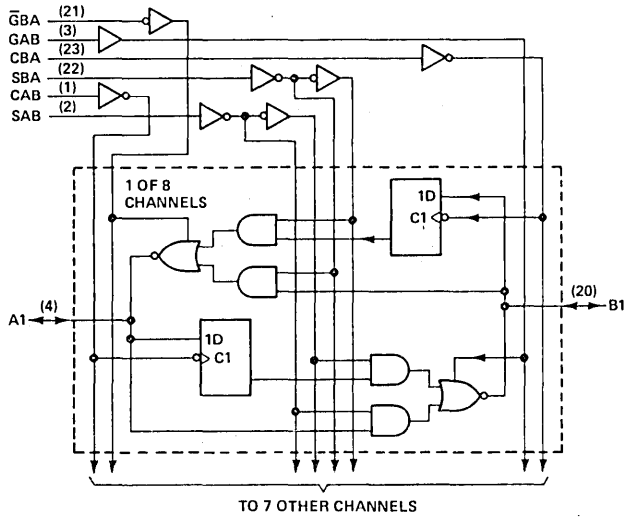

'LS652, 'LS654

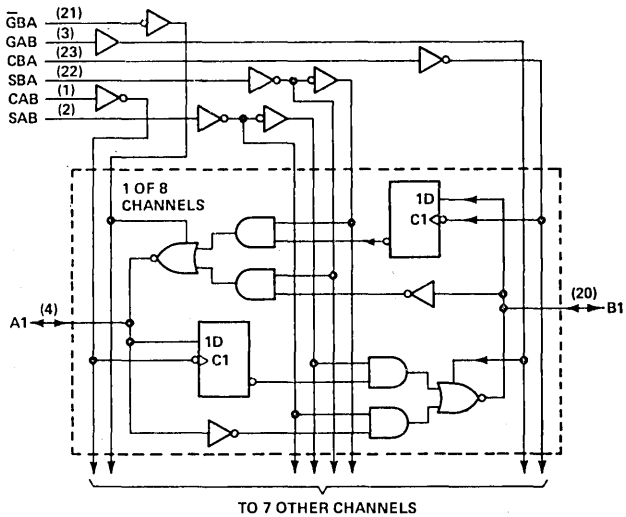

Pin numbers shown on logic notation are for DW, JT or NT packages.

TTL DEVICES

TYPES SN54LS651 THRU SN54LS654 SN74LS651 THRU SN74LS654 OCTAL BUS TRANSCEIVERS AND REGISTERS

logic symbols

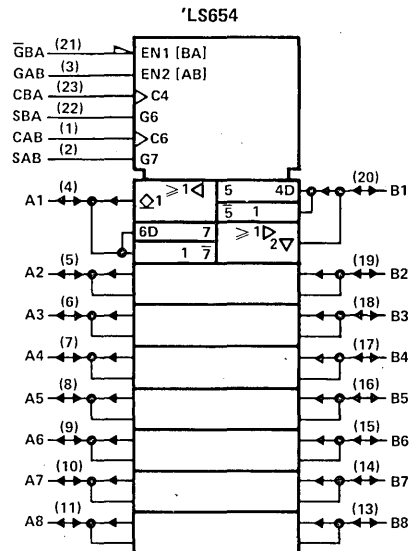
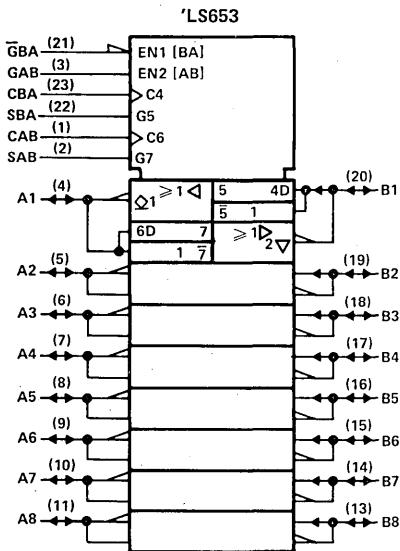
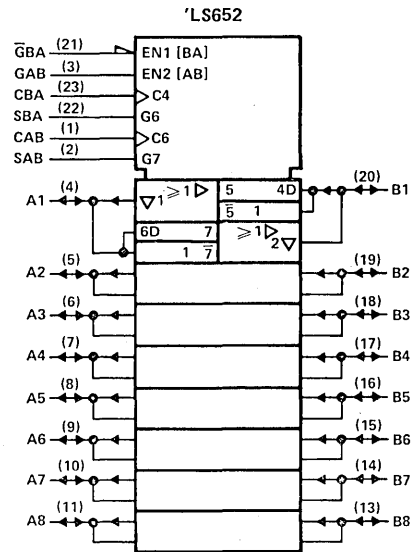
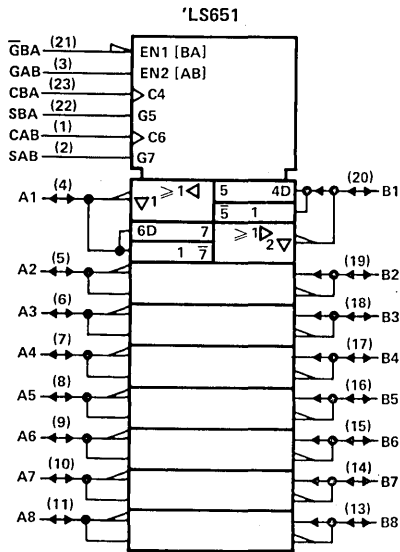

Pin numbers shown on logic notation are for DW, JT or NT packages.

3

TTL DEVICES

TYPES SN54LS651, SN54LS652, SN74LS651, SN74LS652 OCTAL BUS TRANSCEIVERS AND REGISTERS

switching characteristics, $V_{CC} = 5\text{ V}$, $T_A = 25^\circ\text{C}$

PARAMETER	FROM (INPUT)	TO (OUTPUT)	TEST CONDITIONS	'LS651			'LS652			UNIT
				MIN	TYP	MAX	MIN	TYP	MAX	
t_{PLH}	Clock	Bus	$R_L = 667\ \Omega$, $C_L = 45\ \text{pF}$, See Note 2	14	24	15	25	ns		
t_{PHL}				23	35	24	36	ns		
t_{PLH}	Bus	Bus		9	18	12	18	ns		
t_{PHL}				20	30	13	20	ns		
t_{PLH}	Select, with bus input high†	Bus		31	47	23	35	ns		
t_{PHL}				22	33	21	32	ns		
t_{PLH}	Select, with bus input low†	Bus		23	35	33	50	ns		
t_{PHL}				19	30	15	23	ns		
t_{PZH}	$\overline{\text{G}}\text{BA}$	A Bus		29	44	30	45	ns		
t_{PZL}		40		60	36	54	ns			
t_{PZH}	GAB	B Bus		19	29	20	30	ns		
t_{PZL}		26		40	25	38	ns			
t_{PHZ}	$\overline{\text{G}}\text{BA}$	A Bus	25	38	25	38	ns			
t_{PLZ}		19	30	19	30	ns				
t_{PHZ}	GAB	B Bus	25	38	25	38	ns			
t_{PLZ}		19	30	19	30	ns				

t_{PLH} = propagation delay time, low-to-high-level output.

t_{PHL} = propagation delay time, high-to-low-level output

t_{PZH} = output enable time to high level

t_{PZL} = output enable time to low level

t_{PHZ} = output disable time from high level

t_{PLZ} = output disable time from low level

† These parameters are measured with the internal output state of the storage register opposite to that of the bus input.

NOTE 2: See General Information Section for load circuits and voltage waveforms.

schematics of inputs and outputs

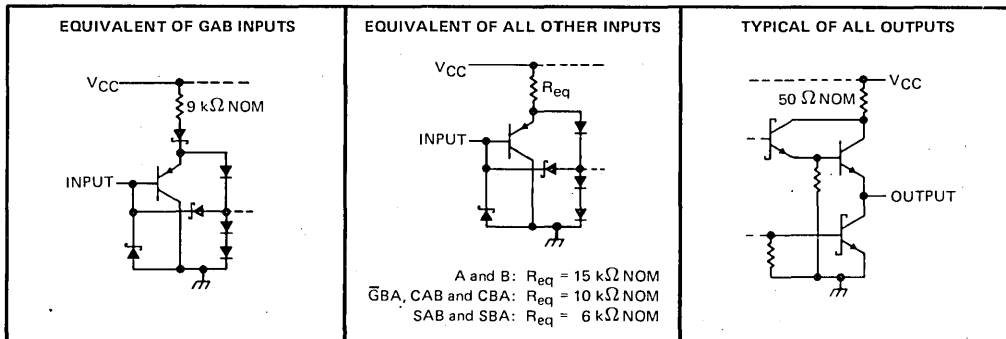

TYPES SN54LS653, SN54LS654, SN74LS653, SN74LS654 OCTAL BUS TRANSCEIVERS AND REGISTERS

absolute maximum ratings over operating free-air temperature range (unless otherwise noted)

Supply voltage, V_{CC}	7 V
Input voltage: All inputs and A I/O ports	7 V
B I/O ports	5.5 V
Operating free-air temperature range: SN54LS653, SN54LS654	-55°C to 125°C
SN74LS653, SN74LS654	0°C to 70°C
Storage temperature range	-65°C to 150°C

recommended operating conditions

		SN54LS653 SN54LS654			SN74LS653 SN74LS654			UNIT
		MIN	NOM	MAX	MIN	NOM	MAX	
V_{CC}	Supply voltage	4.5	5	5.5	4.75	5	5.25	V
V_{IH}	High-level input voltage	2			2			V
V_{IL}	Low-level input voltage	0.7			0.8			V
V_{OH}	High-level output voltage	A ports			5.5			V
I_{OH}	High-level output current	B ports			-12			mA
I_{OL}	Low-level output current				24			mA
t_w	Pulse duration	CBA or CAB high		15	15		ns	
		CBA or CAB low		30	30			
		Data high or low		30	30			
t_{su}	Setup time before CAB † or CBA †	A or B		15	15		ns	
t_h	Hold time after CAB † or CBA †	A or B		0	0		ns	
T_A	Operating free-air temperature	-55	125	0	70	°C		

electrical characteristics over recommended operating free-air temperature range (unless otherwise noted)

PARAMETER		TEST CONDITIONS †		SN54LS653 SN54LS654		SN74LS653 SN74LS654		UNIT	
				MIN	TYP ‡	MAX	MIN		TYP ‡
V_{IK}		$V_{CC} = \text{MIN}, I_I = -18 \text{ mA}$		-1.5		-1.5		V	
V_{OH}	B ports	$V_{CC} = \text{MIN}, V_{IH} = 2 \text{ V}, V_{IL} = \text{MAX}$		$I_{OH} = -3 \text{ mA}$	2.4	3.4	2.4	3.4	V
				$I_{OH} = -12 \text{ mA}$	2				
				$I_{OH} = -15 \text{ mA}$			2		
I_{OH}	A ports	$V_{CC} = \text{MIN}, V_{OH} = 5.5 \text{ V}$		0.1		0.1		mA	
V_{OL}		$V_{CC} = \text{MIN}, V_{IH} = 2 \text{ V}, V_{IL} = \text{MAX}$		$I_{OL} = 12 \text{ mA}$	0.25	0.4	0.25	0.4	V
				$I_{OL} = 24 \text{ mA}$			0.35		
I_I	Control inputs	$V_{CC} = \text{MAX}, V_I = 7 \text{ V}$		0.1		0.1		mA	
	A or B ports	$V_{CC} = \text{MAX}, V_I = 5.5 \text{ V}$		0.1		0.1			
I_{IH}	Control inputs	$V_{CC} = \text{MAX}, V_I = 2.7 \text{ V}$		20		20		µA	
	A or B ports ▲			20		20			
I_{IL}	Control inputs	$V_{CC} = \text{MAX}, V_I = 0.4 \text{ V}$		-0.4		-0.4		mA	
	A or B ports ▲			-0.4		-0.4			
I_{OS} ¶	B ports	$V_{CC} = \text{MAX}, V_O = 0 \text{ V}$		-40	-225	-40	-225	mA	
I_{CC}	LS653	$V_{CC} = \text{MAX}$		Outputs high	95	145	95	145	mA
				Outputs low	103	165	103	165	
	Outputs disabled			103	165	103	165		
	LS654			Outputs high	95	145	95	145	
				Outputs low	105	170	105	170	
	Outputs disabled			120	180	120	180		

† For conditions shown as MIN or MAX, use the appropriate value specified under recommended operating conditions.

‡ All typical values are at $V_{CC} = 5 \text{ V}, T_A = 25^\circ\text{C}$.

¶ Not more than one output should be shorted at a time, and duration of the short-circuit should not exceed one second.

▲ For I/O ports, the parameters I_{IH} and I_{IL} include the off-state output current.

3
TTL DEVICES

TYPES SN54LS653, SN54LS654, SN74LS653, SN74LS654 OCTAL BUS TRANSCEIVERS AND REGISTERS

switching characteristics, $V_{CC} = 5\text{ V}$, $T_A = 25^\circ\text{C}$

PARAMETER	FROM (INPUT)	TO (OUTPUT)	TEST CONDITIONS	'LS653			'LS654			UNIT
				MIN	TYP	MAX	MIN	TYP	MAX	
t_{PLH}	CBA	A Bus	$R_L = 667\ \Omega$, See Note 2	$C_L = 45\ \text{pF}$,	25	38	22	33	ns	
t_{PHL}					26	39	24	36		
t_{PLH}	CAB	B Bus			15	23	14	21	ns	
t_{PHL}					24	36	22	33		
t_{PLH}	A Bus	B Bus			10	18	10	18	ns	
t_{PHL}					20	30	20	30		
t_{PLH}	B Bus	A Bus			21	32	18	27	ns	
t_{PHL}					16	24	14	21		
t_{PLH}	SBA [†] (with B high)	A Bus			38	57	32	48	ns	
t_{PHL}					26	39	21	32		
t_{PLH}	SBA [†] (with B low)	A Bus			34	51	36	54	ns	
t_{PHL}					23	35	19	29		
t_{PLH}	SAB [†] (with A high)	B Bus			32	48	23	35	ns	
t_{PHL}					22	33	18	27		
t_{PLH}	SAB [†] (with A low)	B Bus			24	36	30	45	ns	
t_{PHL}					20	30	14	21		
t_{PLH}	$\bar{G}BA$	A Bus	23	35	23	35	ns			
t_{PHL}			37	55	35	53				
t_{PZH}	GAB	B Bus	$R_L = 667\ \Omega$, See Note 2	$C_L = 5\ \text{pF}$,	19	29	19	29	ns	
t_{PZL}					25	38	22	33		
t_{PHZ}					26	39	26	39		
t_{PLZ}	GAB	B Bus			19	29	19	29	ns	

† These parameters are measured with the internal output state of the storage register opposite to that of the bus input.

NOTE 2: See General Information Section for load circuits and voltage waveforms.

schematics of inputs and outputs

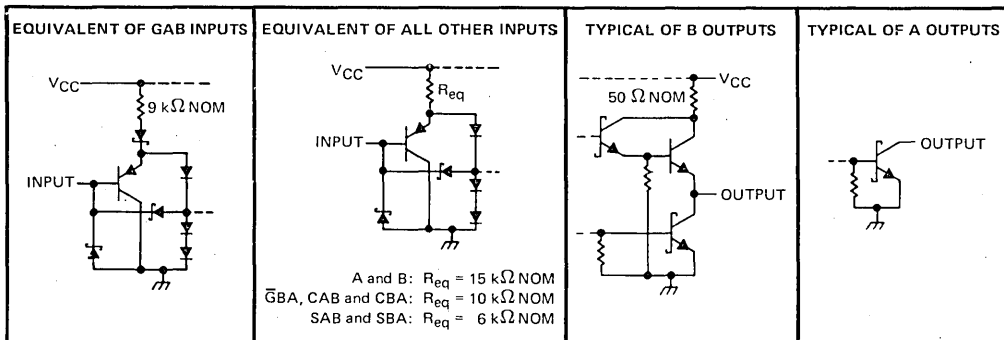

TTL DEVICES

TYPES SN54LS668, SN54LS669, SN74LS668, SN74LS669 SYNCHRONOUS 4-BIT UP/DOWN COUNTERS

D2351, APRIL 1977—REVISED APRIL 1985

'LS668 . . . SYNCHRONOUS UP/DOWN DECADE COUNTERS 'LS669 . . . SYNCHRONOUS UP/DOWN BINARY COUNTERS

Programmable Look-Ahead Up/Down Binary/Decade Counters

- Fully Synchronous Operation for Counting and Programming
- Internal Look-Ahead for Fast Counting
- Carry Output for n-Bit Cascading
- Fully Independent Clock Circuit
- Buffered Outputs

SN54LS668, SN54LS669 . . . J PACKAGE
SN74LS668, SN74LS669 . . . D, J OR N PACKAGE

(TOP VIEW)

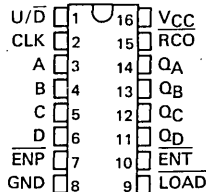

TYPE	TYPICAL MAXIMUM CLOCK FREQUENCY		TYPICAL POWER DISSIPATION
	COUNTING UP	COUNTING DOWN	
'LS668, 'LS669	32 MHz	32 MHz	100 mW

description

These synchronous presettable counters feature an internal carry look-ahead for cascading in high-speed counting applications. The 'LS668 are decade counters and the 'LS669 are 4-bit binary counters. Synchronous operation is provided by having all flip-flops clocked simultaneously so that the outputs change coincident with each other when so instructed by the count-enable inputs and internal gating. This mode of operation helps eliminate the output counting spikes that are normally associated with asynchronous (ripple-clock) counters. A buffered clock input triggers the four master-slave flip-flops on the rising (positive-going) edge of the clock waveform.

These counters are fully programmable; that is, the outputs may each be preset to either level. The load input circuitry allows loading with the carry-enable output of cascaded counters. As loading is synchronous, setting up a low level at the load input disables the counter and causes the outputs to agree with the data inputs after the next clock pulse.

The carry look-ahead circuitry provides for cascading counters for n-bit synchronous applications without additional gating. Instrumental in accomplishing this function are two count-enable inputs and a carry output. Both count enable inputs (P and \bar{T}) must be low to count. The direction of the count is determined by the level of the up/down input. When the input is high, the counter counts up; when low, it counts down. Input \bar{T} is fed forward to enable the carry output. The carry output thus enabled will produce a low-level output pulse when the count is maximum counting up or zero counting down. This low-level overflow carry pulse can be used to enable successive cascaded stages. Transitions at the enable P or \bar{T} inputs are allowed regardless of the level of the clock input. All inputs are diode-clamped to minimize transmission-line effects, thereby simplifying system design.

These counters feature a fully independent clock circuit. Changes at control inputs (enable \bar{P} , enable \bar{T} , load, up/down) that will modify the operating mode have no effect until clocking occurs. The function of the counter (whether enabled, disabled, loading, or counting) will be dictated solely by the conditions meeting the stable setup and hold times.

The 'LS668 and 'LS669 are completely new designs. Compared to the original 'LS168 and 'LS169, they feature 0-nanosecond minimum hold time, reduced input currents I_{IH} and I_{IL} , and all buffered outputs.

SN54LS668, SN54LS669 . . . FK PACKAGE
SN74LS668, SN74LS669 . . . FN PACKAGE

(TOP VIEW)

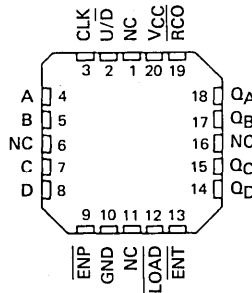

NC — No internal connection

PRODUCTION DATA
This document contains information current as of publication date. Products conform to specifications per the terms of Texas Instruments standard warranty. Production processing does not necessarily include testing of all parameters.

**TEXAS
INSTRUMENTS**

POST OFFICE BOX 225012 • DALLAS, TEXAS 75265

3-1259



TTL DEVICES

TYPES SN54LS668, SN74LS668
SYNCHRONOUS 4-BIT UP/DOWN COUNTERS

logic diagram

SN54LS668, SN74LS668, DECADE COUNTERS

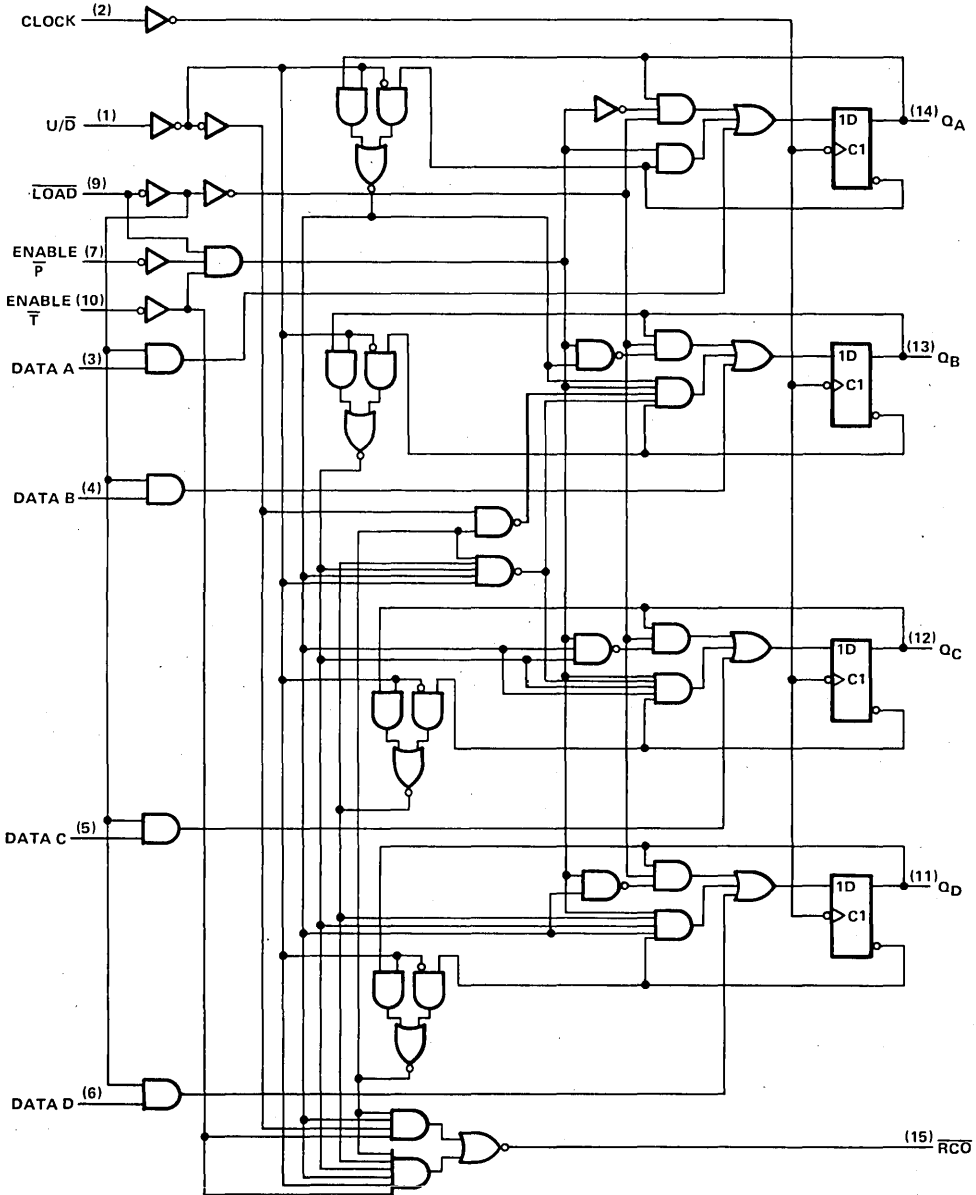

Pin numbers shown on logic notation are for D, J or N packages.

3

TTL DEVICES

TYPES SN54LS669, SN74LS669
 SYNCHRONOUS 4-BIT UP/DOWN COUNTERS

logic diagram (continued)

SN54LS669, SN74LS669, BINARY COUNTERS

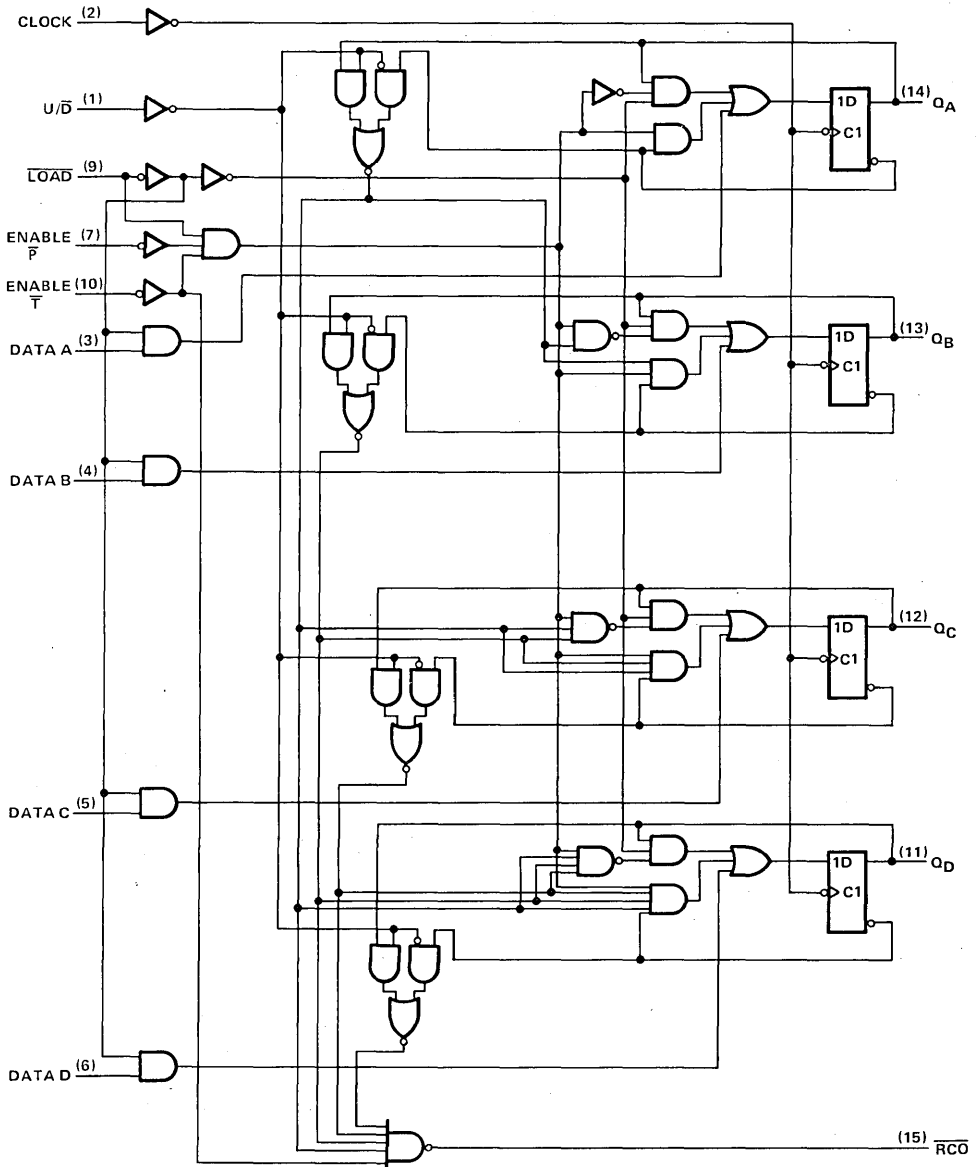

Pin numbers shown on logic notation are for D, J or N packages.



TTL DEVICES

TYPES SN54LS668, SN74LS668
SYNCHRONOUS 4-BIT UP/DOWN COUNTERS

'LS668 DECADE COUNTERS

logic symbol

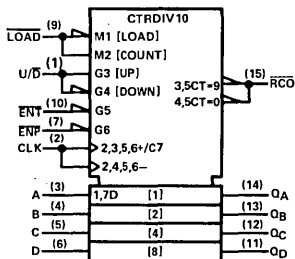

typical load, count, and inhibit sequences

Illustrated below is the following sequence:

1. Load (preset) to BCD seven
2. Count up to eight, nine (maximum), zero, one, and two
3. Inhibit
4. Count down to one, zero (minimum), nine, eight, and seven

Pin numbers shown on logic notation are for D, J or N packages.

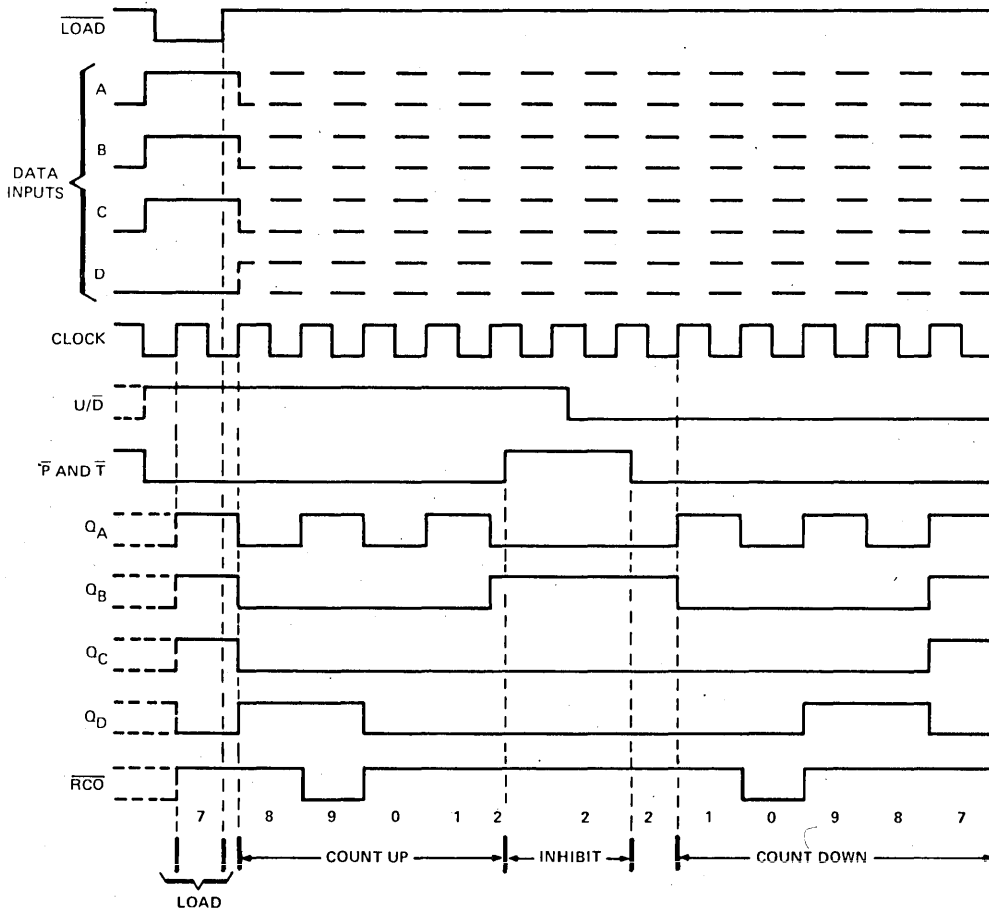

3 TTL DEVICES

TYPES SN54LS669, SN74LS669 SYNCHRONOUS 4-BIT UP/DOWN COUNTERS

'LS669 BINARY COUNTERS

typical load, count, and inhibit sequences

Illustrated below is the following sequence:

1. Load (preset) to binary thirteen
2. Count up to fourteen, fifteen (maximum), zero, one, and two
3. Inhibit
4. Count down to one, zero (minimum), fifteen, fourteen, and thirteen

logic symbol

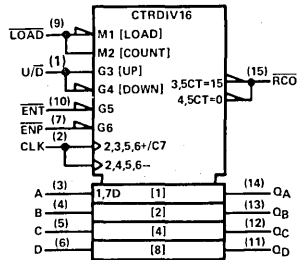

Pin numbers shown on logic notation are for D, J or N packages.

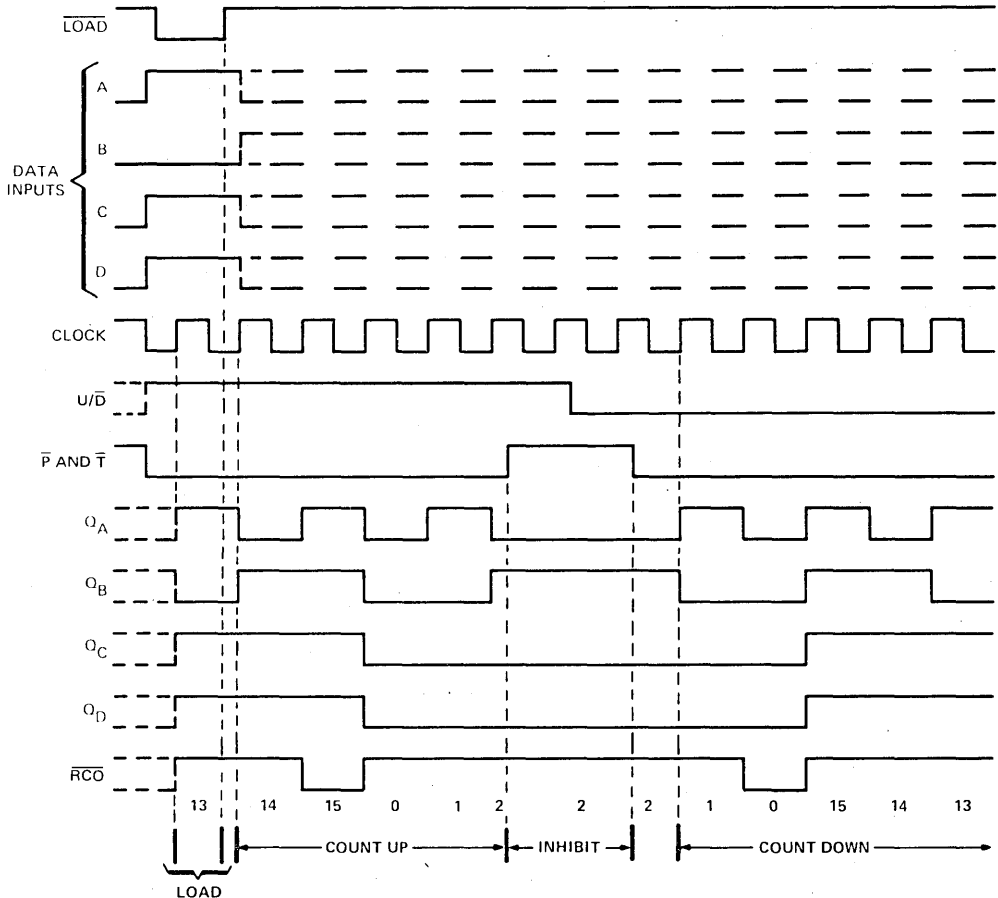

TYPES SN54LS668, SN54LS669, SN74LS668, SN74LS669 SYNCHRONOUS 4-BIT UP/DOWN COUNTERS

schematics of inputs and outputs

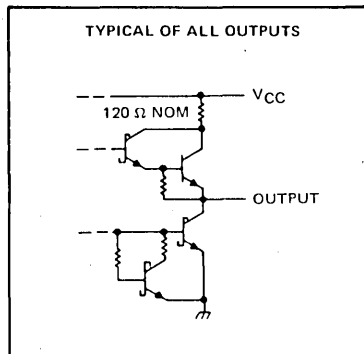
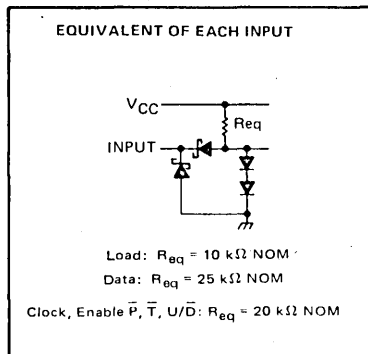

absolute maximum ratings over operating free-air temperature range (unless otherwise noted)

Supply voltage, V_{CC} (see Note 1)	7 V
Input voltage	7 V
Operating free-air temperature range: SN54LS668, SN54LS669	-55°C to 125°C
SN74LS668, SN74LS669	0°C to 70°C
Storage temperature range	-65°C to 150°C

NOTE 1: Voltage values are with respect to network ground terminal.

recommended operating conditions

	SN54LS668 SN54LS669			SN74LS668 SN74LS669			UNIT
	MIN	NOM	MAX	MIN	NOM	MAX	
Supply voltage, V_{CC}	4.5	5	5.5	4.75	5	5.25	V
High-level output current, I_{OH}			-400			-400	μA
Low-level output current, I_{OL}			4			8	mA
Clock frequency, f_{clock}	0		25	0		25	MHz
Width of clock pulse, $t_w(\text{clock})$ (high or low) (see Figure 1)		20			20		ns
Setup time, t_{SU} (see Figure 1)	Data inputs A, B, C, D		25		25		ns
	\bar{ENP} or \bar{ENT}		40		40		
	LOAD		30		30		
	U/\bar{D}		45		45		
Hold time at any input with respect to clock, t_h (see Figure 1)		0			0		ns
Operating free-air temperature, T_A		-55	125		0	70	°C

TYPES SN54LS668, SN54LS669, SN74LS668, SN74LS669 SYNCHRONOUS 4-BIT UP/DOWN COUNTERS

electrical characteristics over recommended operating free-air temperature range (unless otherwise noted)

PARAMETER		TEST CONDITIONS†	SN54LS668 SN54LS669		SN74LS668 SN74LS669		UNIT
			MIN	TYP‡	MAX	MIN	
V _{IH}	High-level input voltage		2		2		V
V _{IL}	Low-level input voltage				0.7		V
V _{IK}	Input clamp voltage	V _{CC} = MIN, I _I = -18 mA			-1.5		V
V _{OH}	High-level output voltage	V _{CC} = MIN, V _{IH} = 2 V, V _{IL} = V _{IL} max, I _{OH} = -400 µA	2.5	3.4	2.7	3.4	V
V _{OL}	Low-level output voltage	V _{CC} = MIN, V _{IH} = 2 V, V _{IL} = V _{IL} max					V
I _I	Input current at maximum input voltage	A, B, C, D, \bar{P} , U/ \bar{D}			0.1		mA
		Clock, \bar{T}	V _{CC} = MAX, V _I = 7 V		0.1		
		LOAD			0.2		
I _{IH}	High-level input current	A, B, C, D, \bar{P} , U/ \bar{D}			20		µA
		Clock, \bar{T}	V _{CC} = MAX, V _I = 2.7 V		20		
		LOAD			40		
I _{IL}	Low-level input current	A, B, C, D, \bar{P} , U/ \bar{D}			-0.4		mA
		Clock, \bar{T}	V _{CC} = MAX, V _I = 0.4 V		-0.4		
		LOAD			-0.8		
I _{OS}	Short-circuit output current §	V _{CC} = MAX	-20	-100	-20	-100	mA
I _{CC}	Supply current	V _{CC} = MAX, See Note 2	20 34		20 34		mA

† For conditions shown as MIN or MAX, use the appropriate value specified under recommended operating conditions.

‡ All typical values are at V_{CC} = 5 V, T_A = 25°C.

§ Not more than one output should be shorted at a time, and duration of the short-circuit should not exceed one second.

NOTE 2: I_{CC} is measured after applying a momentary 4.5 V, then ground, to the clock input with all other inputs grounded and the outputs open.

switching characteristics, V_{CC} = 5 V, T_A = 25°C

PARAMETER¶	FROM (INPUT)	TO (OUTPUT)	TEST CONDITIONS	MIN	TYP	MAX	UNIT
f _{max}			C _L = 15 pF, R _L = 2 kΩ, See Figures 2 and 3	25	32		MHz
‡PLH	CLK	\overline{RCO}		26	40		ns
‡PHL		Any		40	60		ns
‡PLH	CLK	Q		18	27		ns
‡PHL		\overline{ENT}		18	27		ns
‡PLH	U/ \bar{D}	\overline{RCO}		11	17		ns
‡PHL				29	45		ns
‡PLH [⊙]					22	35	
‡PHL [⊙]				26	40		ns

¶ f_{max} = Maximum clock frequency

‡PLH = propagation delay time, low-to-high-level output.

‡PHL = propagation delay time, high-to-low-level output.

⊙ Propagation delay time from up/down to ripple carry must be measured with the counter at either a minimum or a maximum count. As the logic level of the up/down input is changed, the ripple carry output will follow. If the count is minimum (0), the ripple carry output transition will be in phase. If the count is maximum (9 for 'LS668 or 15 for 'LS669), the ripple carry output will be out of phase.

TYPES SN54LS668, SN54LS669, SN74LS668, SN74LS669
 SYNCHRONOUS 4-BIT UP/DOWN COUNTERS

PARAMETER MEASUREMENT INFORMATION

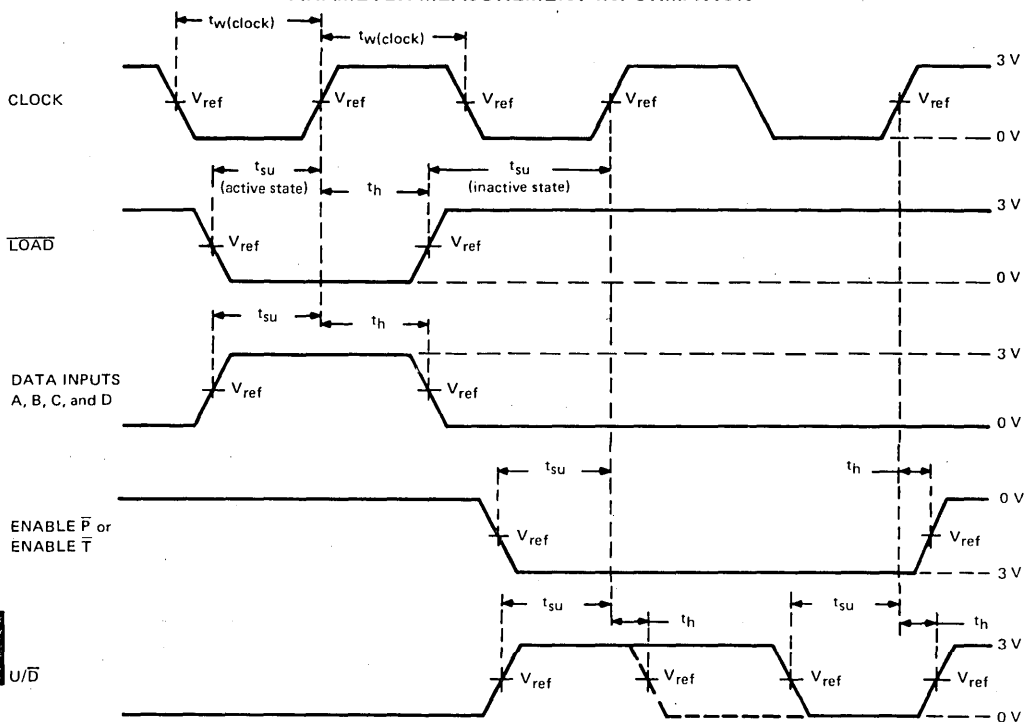

VOLTAGE WAVEFORMS

- NOTES: A. The input pulses are supplied by a generator having the following characteristics: PRR \leq 1 MHz, duty cycle \leq 50%, $Z_{\text{out}} \approx 50 \Omega$; $t_r \leq 15 \text{ ns}$, $t_f \leq 6 \text{ ns}$.
 B. $V_{\text{ref}} = 1.3 \text{ V}$.

FIGURE 1—PULSE WIDTHS, SETUP TIMES, HOLD TIMES

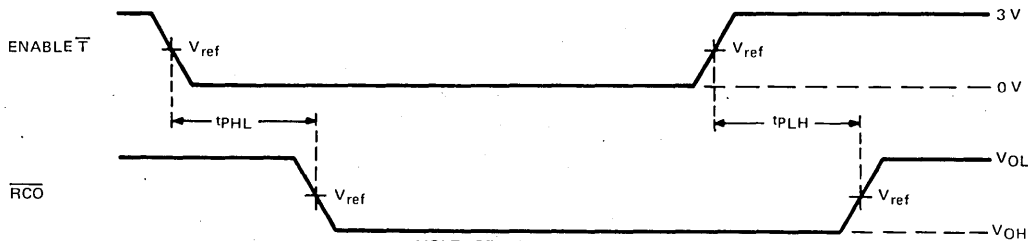

VOLTAGE WAVEFORMS

- NOTES: A. The input pulse is supplied by a generator having the following characteristics: PRR \leq 1 MHz, duty cycle \leq 50%, $Z_{\text{out}} \approx 50 \Omega$; $t_r \leq 15 \text{ ns}$, $t_f \leq 6 \text{ ns}$.
 B. t_{PLH} and t_{PHL} from enable \bar{T} input to ripple carry output assume that the counter is at the maximum count (Q_A and Q_D high for 'LS668, all Q outputs high for 'LS669).
 C. $V_{\text{ref}} = 1.3 \text{ V}$.
 D. Propagation delay time from up/down to ripple carry must be measured with the counter at either a minimum or a maximum count. As the logic level of the up/down input is changed, the ripple carry output will follow. If the count is minimum (0) the ripple carry output transition will be in phase. If the count is maximum (9 for 'LS668, or 15 for 'LS669) the ripple carry output will be out of phase.

FIGURE 2—PROPAGATION DELAY TIMES TO CARRY OUTPUT

3
 TTL DEVICES

TYPES SN54LS668, SN54LS669, SN74LS668, SN74LS669
 SYNCHRONOUS 4-BIT UP/DOWN COUNTERS

PARAMETER MEASUREMENT INFORMATION

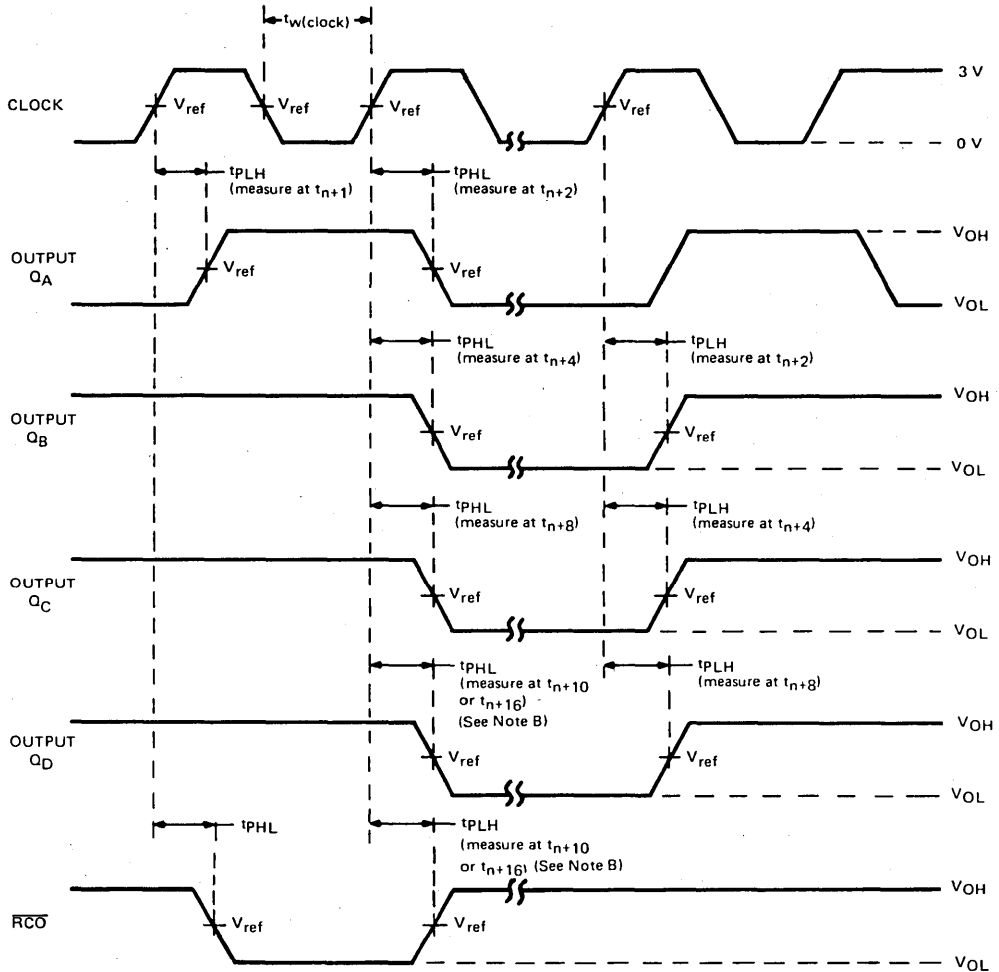

UP-COUNT VOLTAGE WAVEFORMS

- NOTES: A. The input pulses are supplied by a generator having the following characteristics: PRR \leq 1 MHz, duty cycle \leq 50%, $Z_{out} \approx 50 \Omega$, $t_r \leq 15$ ns, $t_f \leq 6$ ns. Vary PRR to measure f_{max} .
- B. Outputs Q_D and carry are tested at t_{n+10} for the 'LS668, and at t_{n+16} for the 'LS669, where t_n is the bit-time when all outputs are low.
- C. $V_{ref} = 1.3$ V.

FIGURE 3—PROPAGATION DELAY TIMES FROM CLOCK

3
 TTL DEVICES



TTL DEVICES

TYPES SN54LS670, SN74LS670 4-BY-4 REGISTER FILES WITH 3-STATE OUTPUTS

BULLETIN NO. DL-S 7612122, MARCH 1974-REVISED DECEMBER 1983

- Separate Read/Write Addressing Permits Simultaneous Reading and Writing
- Fast Access Times . . . Typically 20 ns
- Organized as 4 Words of 4 Bits
- Expandable to 512 Words of n-Bits
- For Use as:
 - Scratch-Pad Memory
 - Buffer Storage between Processors
 - Bit Storage in Fast Multiplication Designs
- 3-State Outputs
- SN54LS170 and SN74LS170 Are Similar But Have Open-Collector Outputs

SN54LS670 . . . J OR W PACKAGE
SN74LS670 . . . D, J OR N PACKAGE

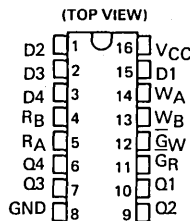

SN54LS670 . . . FK PACKAGE
SN74LS670 . . . FN PACKAGE

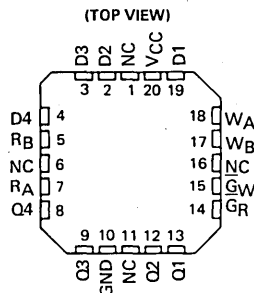

NC — No internal connection.

description

The SN54LS670 and SN74LS670 MSI 16-bit TTL register files incorporate the equivalent of 98 gates. The register file is organized as 4 words of 4 bits each and separate on-chip decoding is provided for addressing the four word locations to either write-in or retrieve data. This permits simultaneous writing into one location and reading from another word location.

Four data inputs are available which are used to supply the 4-bit word to be stored. Location of the word is determined by the write-address inputs A and B in conjunction with a write-enable signal. Data applied at the inputs should be in its true form. That is, if a high-level signal is desired from the output, a high-level is applied at the data input for that particular bit location. The latch inputs are arranged so that new data will be accepted only if both internal address gate inputs are high. When this condition exists, data at the D input is transferred to the latch output. When the write-enable input, \overline{G}_W , is high, the data inputs are inhibited and their levels can cause no change in the information stored in the internal latches. When the read-enable input, \overline{G}_R , is high, the data outputs are inhibited and go into the high-impedance state.

The individual address lines permit direct acquisition of data stored in any four of the latches. Four individual decoding gates are used to complete the address for reading a word. When the read address is made in conjunction with the read-enable signal, the word appears at the four outputs.

This arrangement—data-entry addressing separate from data-read addressing and individual sense line—eliminates recovery times, permits simultaneous reading and writing, and is limited in speed only by the write time (27 nanoseconds typical) and the read time (24 nanoseconds typical). The register file has a nondestructive readout in that data is not lost when addressed.

All inputs except read enable and write enable are buffered to lower the drive requirements to one Series 54LS/74LS standard load, and input-clamping diodes minimize switching transients to simplify system design. High-speed, double-ended AND-OR-INVERT gates are employed for the read-address function and have high-sink-current, three-state outputs. Up to 128 of these outputs may be bus connected for increasing the capacity up to 512 words. Any number of these registers may be paralleled to provide n-bit word length.

The SN54LS670 is characterized for operation over the full military temperature range of -55°C to 125°C ; the SN74LS670 is characterized for operation from 0°C to 70°C .

PRODUCTION DATA
This document contains information current as of publication date. Products conform to specifications per the terms of Texas Instruments standard warranty. Production processing does not necessarily include testing of all parameters.

TEXAS INSTRUMENTS
POST OFFICE BOX 225012 • DALLAS, TEXAS 75265

3-1269

TTL DEVICES

TYPES SN54LS670, SN74LS670

4-BY-4 REGISTER FILES WITH 3-OUTPUTS

logic

WRITE FUNCTION TABLE (SEE NOTES A, B, AND C)

WRITE INPUTS			WORD			
W _B	W _A	\bar{G}_W	0	1	2	3
L	L	L	Q = D	Q ₀	Q ₀	Q ₀
L	H	L	Q ₀	Q = D	Q ₀	Q ₀
H	L	L	Q ₀	Q ₀	Q = D	Q ₀
H	H	L	Q ₀	Q ₀	Q ₀	Q = D
X	X	H	Q ₀	Q ₀	Q ₀	Q ₀

READ FUNCTION TABLE (SEE NOTES A AND D)

READ INPUTS			OUTPUTS			
R _B	R _A	\bar{G}_R	Q1	Q2	Q3	Q4
L	L	L	W0B1	W0B2	W0B3	W0B4
L	H	L	W1B1	W1B2	W1B3	W1B4
H	L	L	W2B1	W2B2	W2B3	W2B4
H	H	L	W3B1	W3B2	W3B3	W3B4
X	X	H	Z	Z	Z	Z

- NOTES: A. H = high level, L = low level, X = irrelevant, Z = high impedance (off)
 B. (Q = D) = The four selected internal flip-flop outputs will assume the states applied to the four external data inputs.
 C. Q₀ = the level of Q before the indicated input conditions were established.
 D. W0B1 = The first bit of word 0, etc.

schematics of inputs and outputs

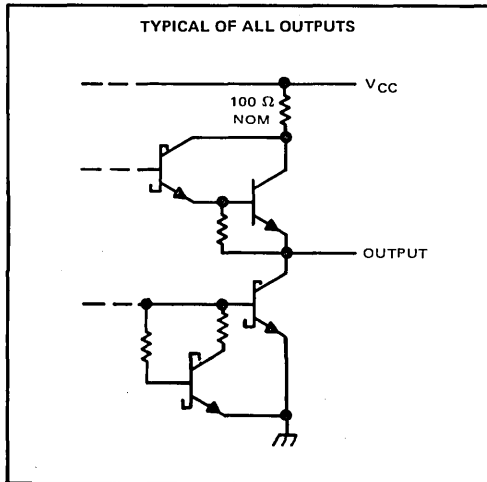
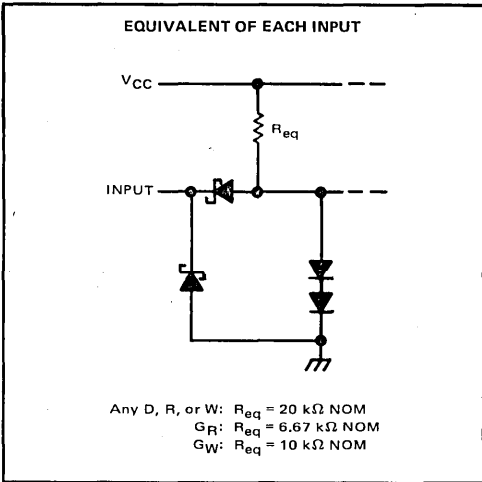

3 TTL DEVICES

TYPES SN54LS670, SN74LS670
4-BY-4 REGISTER FILES WITH 3-STATE OUTPUTS

logic diagram

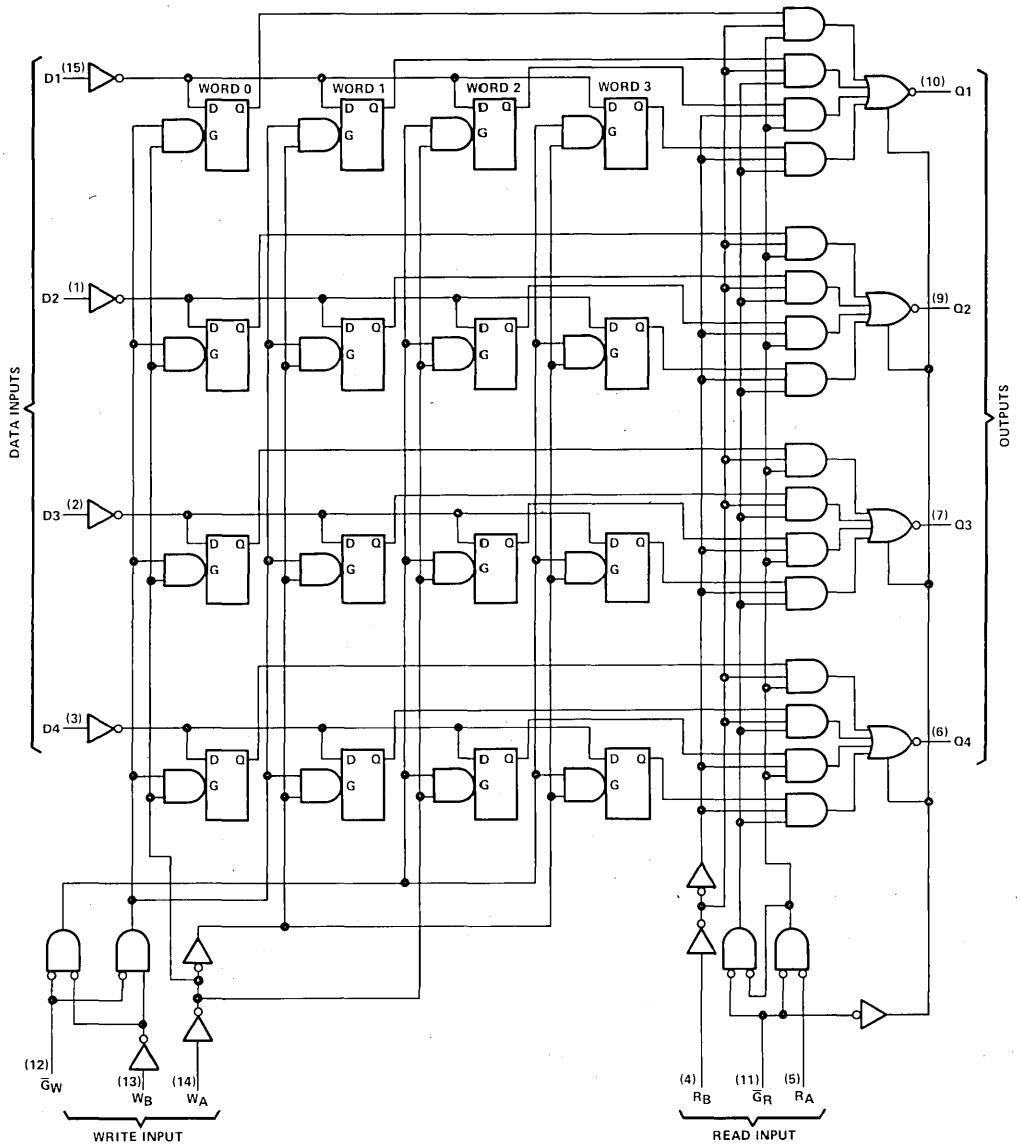

Pin numbers shown on logic notation are for D, J or N packages.



TTL DEVICES

TYPES SN54LS670, SN74LS670

4-BY-4 REGISTER FILES WITH 3-STATE OUTPUTS

absolute maximum ratings over operating free-air temperature range (unless otherwise noted)

Supply voltage, V_{CC} (see Note 1)	7 V
Input voltage	7 V
Off-state output voltage	5.5 V
Operating free-air temperature range: SN54LS670	-55°C to 125°C
SN74LS670	0°C to 70°C
Storage temperature range	-65°C to 150°C

recommended operating conditions

	SN54LS670			SN74LS670			UNIT
	MIN	NOM	MAX	MIN	NOM	MAX	
Supply voltage, V_{CC}	4.5	5	5.5	4.75	5	5.25	V
High-level output current, I_{OH}							-1
Low-level output current, I_{OL}							4
Width of write-enable or read-enable pulse, t_w	25			25			ns
Setup times, high- or low-level data (see Figure 2)	Data input with respect to write enable, $t_{su}(D)$		10	Data input with respect to write enable, $t_{su}(W)$		10	ns
	Write select with respect to write enable, $t_{su}(W)$		15	Write select with respect to write enable, $t_{su}(W)$		15	ns
Hold times, high- or low-level data (see Note 2 and Figure 2)	Data input with respect to write enable, $t_h(D)$		15	Data input with respect to write enable, $t_h(D)$		15	ns
	Write select with respect to write enable, $t_h(W)$		5	Write select with respect to write enable, $t_h(W)$		5	ns
Latch time for new data, t_{latch} (see Note 3)	25			25			ns
Operating free-air temperature range, T_A	-55		125	0		70	°C

- NOTES: 1. Voltage values are with respect to network ground terminal.
2. Write-select setup time will protect the data written into the previous address. If protection of data in the previous address is not required, $t_{su}(W)$ can be ignored as any address selection sustained for the final 30 ns of the write-enable pulse and during $t_h(W)$ will result in data being written into that location. Depending on the duration of the input conditions, one or a number of previous addresses may have been written into.
3. Latch time is the time allowed for the internal output of the latch to assume the state of new data. See Figure 2. This is important only when attempting to read from a location immediately after that location has received new data.

3 TTL DEVICES

TYPES SN54LS670, SN74LS670
4-BY-4 REGISTER FILES WITH 3-STATE OUTPUTS

electrical characteristics over recommended operating free-air temperature range (unless otherwise noted)

PARAMETER	TEST CONDITIONS†	SN54LS670			SN74LS670			UNIT
		MIN	TYP‡	MAX	MIN	TYP‡	MAX	
V _{IH} High-level input voltage		2			2			V
V _{IL} Low-level input voltage				0.7			0.8	V
V _{IK} Input clamp voltage	V _{CC} = MIN, I _I = -18 mA			-1.5			-1.5	V
V _{OH} High-level output voltage	V _{CC} = MIN, V _{IH} = 2 V, V _{IL} = V _{IL} max		I _{OH} = -1 mA I _{OH} = -2.6 mA	2.4 3.4			2.4 3.1	V
V _{OL} Low-level output voltage	V _{CC} = MIN, V _{IH} = 2 V, V _{IL} = V _{IL} max		I _{OL} = 4 mA I _{OL} = 8 mA	0.25 0.4			0.25 0.4 0.35 0.5	V
I _{OZH} Off-state output current, high-level voltage applied	V _{CC} = MAX, V _{IH} = 2 V, V _O = 2.7 V			20			20	µA
I _{OZL} Off-state output current, low-level voltage applied	V _{CC} = MAX, V _{IH} = 2 V, V _O = 0.4 V			-20			-20	µA
I _I Input current at maximum input voltage	V _{CC} = MAX, V _I = 7 V	Any D, R, or W		0.1			0.1	mA
		\bar{G}_W		0.2			0.2	
		\bar{G}_R		0.3			0.3	
I _{IH} High-level input current	V _{CC} = MAX, V _I = 2.7 V	Any D, R, or W		20			20	µA
		\bar{G}_W		40			40	
		\bar{G}_R		60			60	
I _{IL} Low-level input current	V _{CC} = MAX, V _I = 0.4 V	Any D, R, or W		-0.4			-0.4	mA
		\bar{G}_W		-0.8			-0.8	
		\bar{G}_R		-1.2			-1.2	
I _{OS} Short-circuit output current§	V _{CC} = MAX			-30			-130	mA
I _{CC} Supply current	V _{CC} = MAX, See Note 4			30			50	mA

† For conditions shown as MIN or MAX, use the appropriate value specified under recommended operating conditions.

‡ All typical values are at V_{CC} = 5 V, T_A = 25°C.

§ Not more than one output should be shorted at a time, and duration of the short-circuit should not exceed one second.

NOTE 4: Maximum I_{CC} is guaranteed for the following worst-case conditions: 4.5 V is applied to all data inputs and both enable inputs, all address inputs are grounded and all outputs are open.

switching characteristics, V_{CC} = 5 V, T_A = 25°C

PARAMETER¶	FROM (INPUT)	TO (OUTPUT)	TEST CONDITIONS	MIN	TYP	MAX	UNIT
t _{PLH}	Read select	Any Q	C _L = 15 pF, R _L = 2 kΩ, See Figures 1 and 2	23	40	ns	
t _{PHL}				25	45		
t _{PLH}	Write enable	Any Q	C _L = 15 pF, R _L = 2 kΩ, See Figures 1 and 3	26	45	ns	
t _{PHL}				28	50		
t _{PLH}	Data	Any Q	C _L = 15 pF, R _L = 2 kΩ, See Figures 1 and 3	25	45	ns	
t _{PHL}				23	40		
t _{PZH}	Read enable	Any Q	C _L = 15 pF, R _L = 2 kΩ, See Figures 1 and 4	15	35	ns	
t _{PZL}				22	40		
t _{PHZ}				30	50		
t _{PLZ}			See Figures 1 and 4	16	35	ns	

¶ t_{PLH} = propagation delay time, low-to-high-level output
t_{PHL} = propagation delay time, high-to-low-level output
t_{PZH} = output enable time to high level
t_{PZL} = output enable time to low level
t_{PHZ} = output disable time from high level
t_{PLZ} = output disable time from low level



TTL DEVICES

TYPES SN54LS670, SN74LS670
4-BY-4 REGISTER FILES WITH 3-STATE OUTPUTS

PARAMETER MEASUREMENT INFORMATION

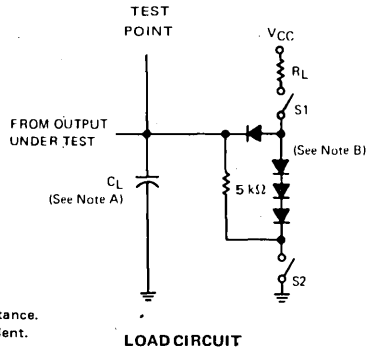

NOTES: A. C_L includes probe and jig capacitance.
B. All diodes are 1N3064 or equivalent.

FIGURE 1

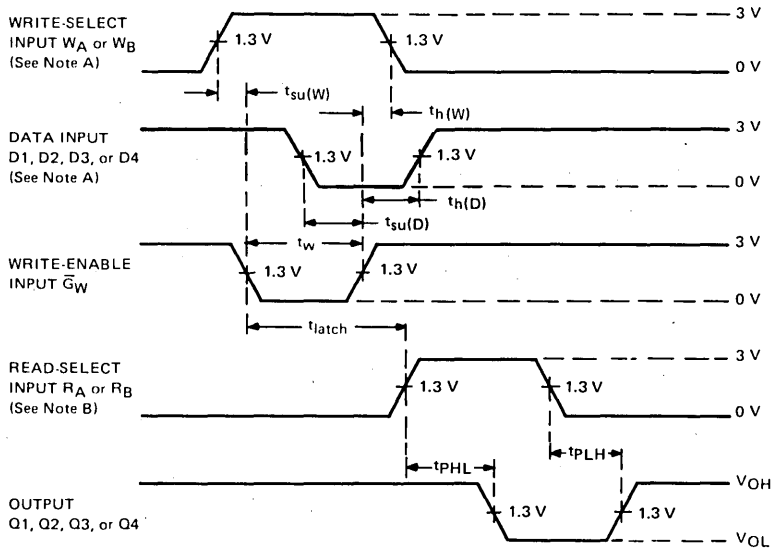

VOLTAGE WAVEFORMS (S1 AND S2 ARE CLOSED)

NOTES: A. High-level input pulses at the select and data inputs are illustrated; however, times associated with low-level pulses are measured from the same reference points.
B. When measuring delay times from a read-select input, the read-enable input is low.
C. Input waveforms are supplied by generators having the following characteristics: $PRR \leq 2 \text{ MHz}$, $Z_{out} \approx 50 \Omega$, duty cycle $\leq 50\%$, $t_r \leq 15 \text{ ns}$, $t_f \leq 6 \text{ ns}$.

FIGURE 2

3 TTL DEVICES

TYPES SN54LS670, SN74LS670
4-BY-4 REGISTER FILES WITH 3-STATE OUTPUTS

PARAMETER MEASUREMENT INFORMATION

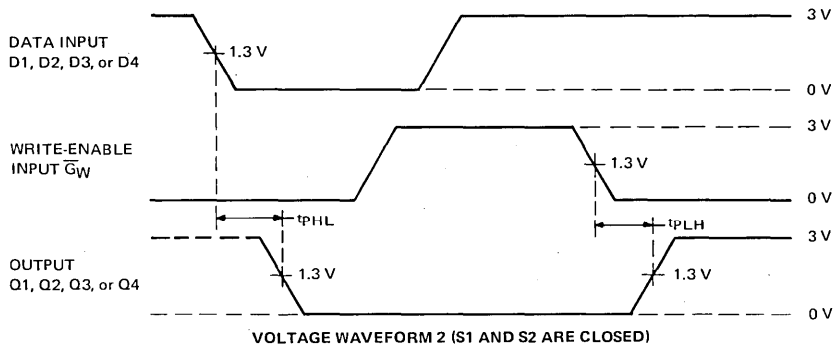
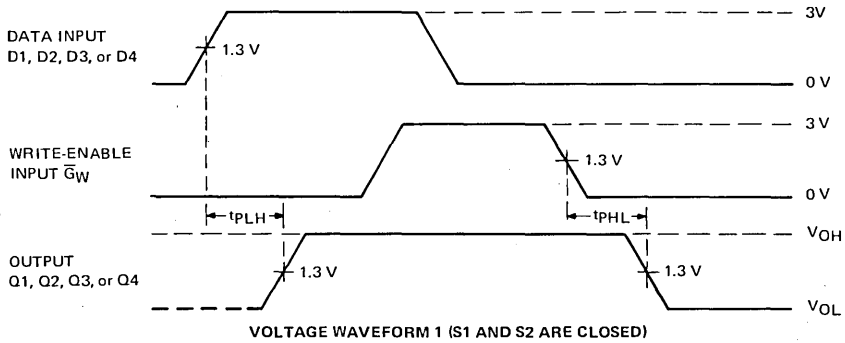

- NOTES: A. Each select address is tested. Prior to the start of each of the above tests both write and read address inputs are stabilized with $W_A = R_A$ and $W_B = R_B$. During the test G_R is low.
B. Input waveforms are supplied by generators having the following characteristics: $PRR \leq 1$ MHz, $Z_{Out} \approx 50 \Omega$, duty cycle $\leq 50\%$, $t_r \leq 15$ ns, $t_f \leq 6$ ns.

FIGURE 3

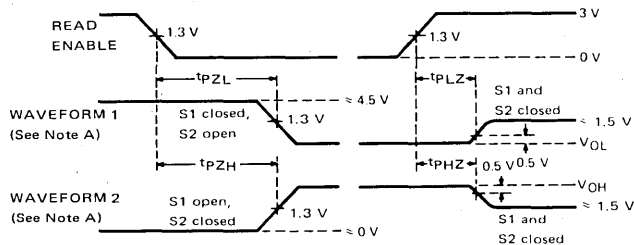

VOLTAGE WAVEFORMS
ENABLE AND DISABLE TIMES, THREE-STATE OUTPUTS

- NOTES: A. Waveforms 1 is for an output with internal conditions such that the output is low except when disabled by the read-enable input. Waveform 2 is for an output with internal conditions such that the output is high except when disabled by the read-enable input.
B. When measuring delay times from the read-enable input, both read-select inputs have been established at steady states.
C. Input waveforms are supplied by generators having the following characteristics: $PRR \leq 1$ MHz, $Z_{Out} \approx 50 \Omega$, duty cycle $\leq 50\%$, $t_r \leq 15$ ns, $t_f \leq 6$ ns.

FIGURE 4



TTL DEVICES



TTL DEVICES

TYPES SN54LS671, SN54LS672, SN74LS671, SN74LS672 4-BIT UNIVERSAL SHIFT REGISTERS/LATCHES WITH 3-STATE OUTPUTS

D2638, JANUARY 1981

- 4-Bit Universal Shift Registers/Latches
- Multiplexed Outputs for Shift Register or Latched Data
- Choice of Direct SR Clear ('LS671) or Synchronous SR Clear ('LS672)
- 3-State Outputs Drive Bus Lines Directly
- Expandable to Any Word Length

description

The 'LS671 and 'LS672 each contain a 4-bit universal shift register (similar to the 'LS194A) and a 4-bit storage register (similar to the 'LS175) multiplexed to a 3-state output stage (similar to the 'LS258). The user has the option of selecting the shift or storage register via the register/shift select input R/\bar{S} . The 'LS671 has a direct-overriding shift register clear while the 'LS672 features a synchronous shift register clear. The shift register has four distinct modes of operation, namely:

- Inhibit clock (do nothing)
- Shift right (in the direction Q_A toward Q_D)
- Shift left (in the direction Q_D toward Q_A)
- Parallel (broadside) load

A cascade output for the shift register is provided so that full shift register functionality is provided even while the outputs are in the high-impedance mode. The cascade output presents Q_A data in the shift-left mode, Q_D data in the shift-right mode.

Both the shift register clock and the latch clock are triggered on the positive transition. The output control (\bar{G}) activates Q_A thru Q_D when low, it places Q_A thru Q_D into the high-impedance state when high.

SN54LS671, SN54LS672 ... J PACKAGE
SN74LS671, SN74LS672 ... DW, J OR N PACKAGE
(TOP VIEW)

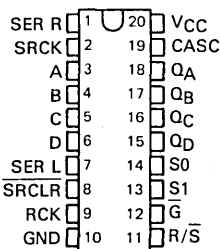

SN54LS671, SN54LS672 ... FK PACKAGE
SN74LS671, SN74LS672 ... FN PACKAGE
(TOP VIEW)

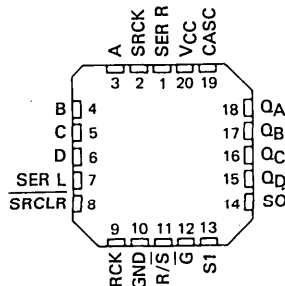

PRODUCTION DATA

This document contains information current as of publication date. Products conform to specifications per the terms of Texas Instruments standard warranty. Production processing does not necessarily include testing of all parameters.

TEXAS
INSTRUMENTS

POST OFFICE BOX 225012 • DALLAS, TEXAS 75265

3-1277

TYPES SN54LS671, SN54LS672, SN74LS671, SN74LS672
4-BIT UNIVERSAL SHIFT REGISTERS/LATCHES WITH 3-STATE OUTPUTS

logic diagram (positive logic)

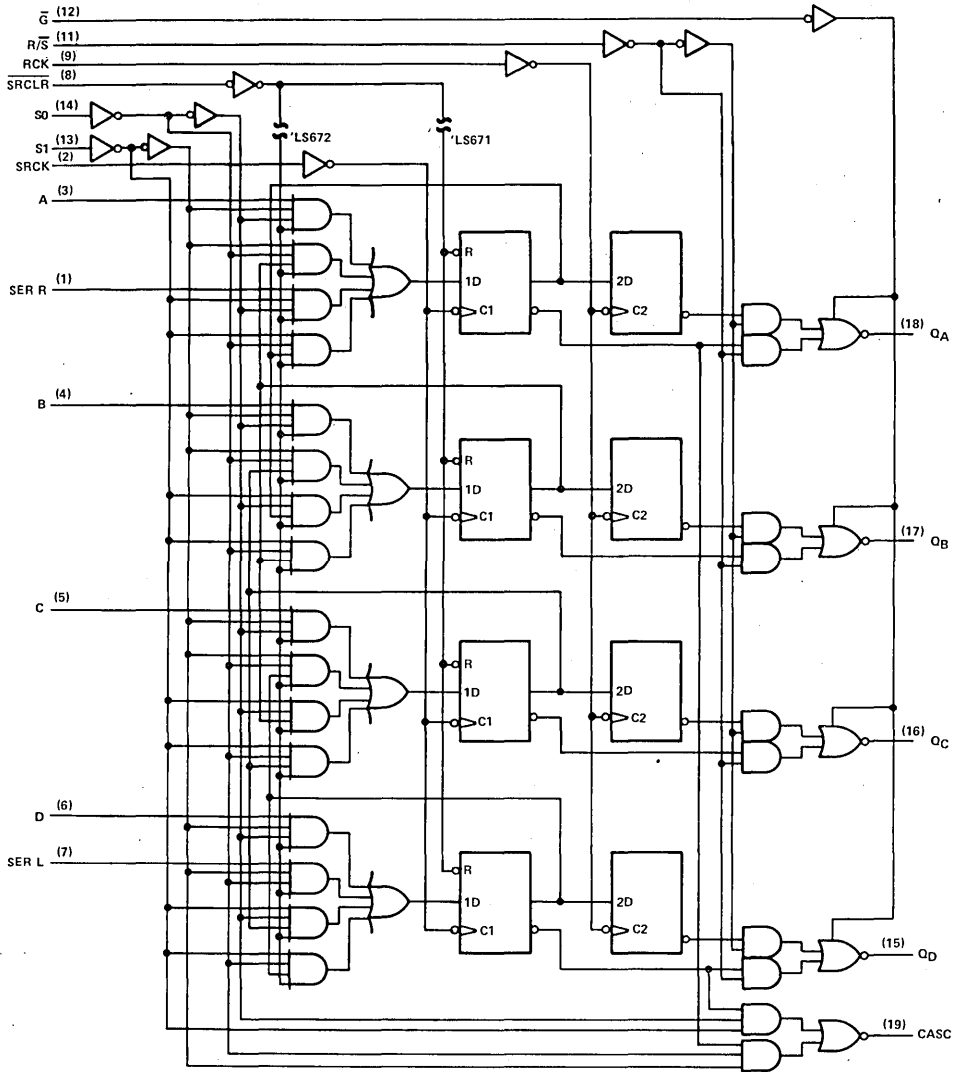

Pin numbers shown on logic notation are for DW, J or N packages.

3
TTL DEVICES

TYPES SN54LS671, SN54LS672, SN74LS671, SN74LS672 4-BIT UNIVERSAL SHIFT REGISTERS/LATCHES WITH 3-STATE OUTPUTS

logic symbols

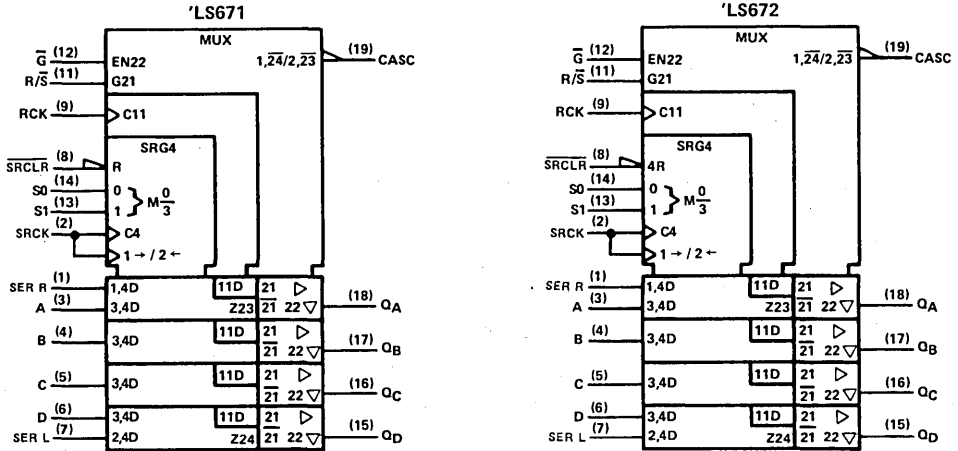

Pin numbers shown on logic notation are for DW, J or N packages.

FUNCTION TABLE

	\bar{G}	R/S	SR MODE		SRCK		SERIAL INPUTS		PARALLEL INPUTS				PARALLEL OUTPUTS				CASC*
			SRCLR	S1	S0	'LS671	'LS672	SL	SR	A	B	C	D	QA	QB	QC	
L	L	L	X	X	X	↑	X	X	X	X	X	X	L	L	L	L	(*)
L	L	H	X	X	L	L	X	X	X	X	X	X	QA0	QB0	QC0	QD0	(*)
L	L	H	L	L	X	X	X	X	X	X	X	X	QA0	QB0	QC0	QD0	H
L	L	H	L	H	↑	↑	X	H	X	X	X	X	H	QA _n	QB _n	QC _n	QC _n
L	L	H	L	H	↑	↑	X	L	X	X	X	X	L	QA _n	QB _n	QC _n	QC _n
L	L	H	H	L	↑	↑	H	X	X	X	X	X	QB _n	QC _n	QD _n	H	QB _n
L	L	H	H	L	↑	↑	L	X	X	X	X	X	QB _n	QC _n	QD _n	H	QB _n
L	L	H	H	H	↑	↑	X	X	a	b	c	d	a	b	c	d	H
H	X	X	L	H	↑	↑	X	X	X	X	X	X	Z	Z	Z	Z	QC _n
H	X	X	H	L	↑	↑	X	X	X	X	X	X	Z	Z	Z	Z	QB _n
L	H	X	X	X	X	X	X	X	X	X	X	X	Internal register contents				(*)

When the output control \bar{G} is high, the 3-state outputs are disabled to the high-impedance state; however, sequential operation of the shift register and the output at CASC are not affected.

H = high level (steady state)

L = low level (steady state)

X = Irrelevant (any input, including transitions)

↑ = transition from low to high level

a, b, c, d = the level of steady-state input at A, B, C, or D, respectively

QA0, QB0, QC0, QD0 = the level of QA, QB, QC, or QD, respectively, before the indicated steady-state input conditions were established

QA_n, QB_n, QC_n = the level of QA, QB, or QC, respectively, before the most-recent transition of the clock

Z = high-impedance state

*The cascade output displays the D bit of the shift register in mode 1 (S1, S0 = L, H), the A bit in mode 2 (S1, S0 = HL), and is inactive (H) in modes 0 and 3 (S1, S0 = LL and HH).

3
TTL DEVICES

TYPES SN54LS671, SN54LS672, SN74LS671, SN74LS672

4-BIT UNIVERSAL SHIFT REGISTERS/LATCHES WITH 3-STATE OUTPUTS

schematics of inputs and outputs

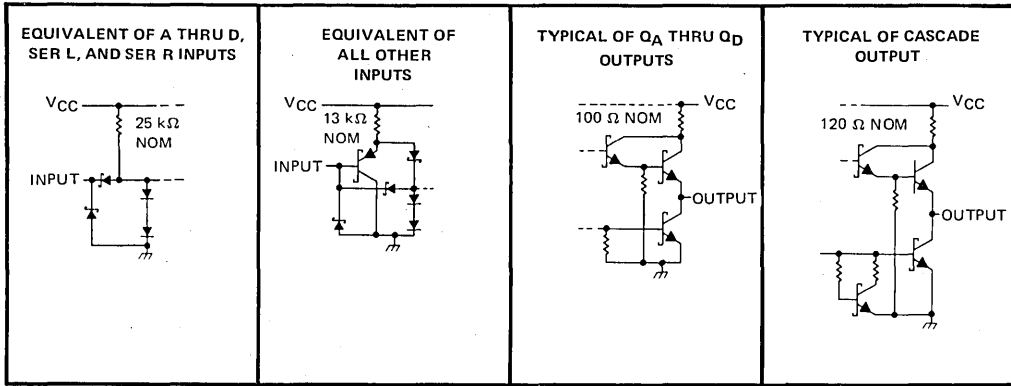

absolute maximum ratings over operating free-air temperature range (unless otherwise noted)

Supply voltage V_{CC} (see Note 1)	7 V
Input voltage	7 V
Off-state output voltage	5.5 V
Operating free-air temperature range: SN54LS671, SN54LS672	-55°C to 125°C
SN74LS671, SN74LS672	0°C to 70°C
Storage temperature range	-65°C to 150°C

NOTE 1: Voltage values are with respect to the network ground terminal.

recommended operating conditions

		SN54LS'			SN74LS'			UNIT		
		MIN	NOM	MAX	MIN	NOM	MAX			
V_{CC}	Supply voltage	4.5	5	5.5	4.75	5	5.25	V		
I_{OH}	High-level output current	Cascade out		-0.4	-0.4		mA			
		Q_A, Q_B, Q_C, Q_D		-1	-2.6					
I_{OL}	Low-level output current	Cascade out		4	8		mA			
		Q_A, Q_B, Q_C, Q_D		12	24					
t_w	Width of SRCK, RCK, or SRCLR ('LS671 only) input pulse	30			30			ns		
t_{su}	Inactive state setup time	SRCLR before SRCK ↑ ('LS671 only)			30			ns		
t_{su}	Setup time	S0 or S1 to SRCK ↑		45	45		ns			
		SRCLR ↓ ('LS672 only) to SRCK ↑		25	25					
		A, B, C, D to SRCK ↑		30	30					
		SRCK ↑ to RCK ↑		30	30					
		SER to SRCK ↑		35	35					
t_h	Hold time	Any input from SRCK ↑			0			ns		
T_A	Operating free-air temperature	-55			125			0	70	°C

3

TTL DEVICES

TYPES SN54LS671, SN54LS672, SN74LS671, SN74LS672

4-BIT UNIVERSAL SHIFT REGISTERS/LATCHES WITH 3-STATE OUTPUTS

electrical characteristics over recommended operating free-air temperature range (unless otherwise noted)

PARAMETER		TEST CONDITIONS†	SN54LS'		SN74LS'		UNIT		
			MIN	TYP‡	MAX	MIN		TYP‡	MAX
V _{IH}	High-level input voltage		2		2		V		
V _{IL}	Low-level input voltage				0.8		V		
V _{IK}	Input clamp voltage	V _{CC} = MIN, I _I = -18 mA			-1.5		V		
V _{OH}	High-level output voltage	Q _A - Q _D	V _{CC} = MIN, V _{IH} = 2 V	I _{OH} = -1 mA	2.4	3.1	V		
		Q _A - Q _D	V _{IH} = 2 V, V _{IL} = V _{IL max}	I _{OH} = -2.6 mA					
		CASC		I _{OH} = -400 μA	2.5	3.2		2.4	3.1
V _{OL}	Low-level output voltage	Q _A - Q _D	V _{CC} = MIN, V _{IH} = 2 V	I _{OL} = 12 mA	0.25	0.4	0.25	0.4	
		Q _A - Q _D		I _{OL} = 24 mA			0.35	0.5	
		CASC		I _{OL} = 4 mA	0.25	0.4	0.25	0.4	
		CASC		I _{OL} = 8 mA			0.35	0.5	
I _{OZH}	Off-state output current, high-level voltage applied	Q _A - Q _D	V _{CC} = MAX, V _{IH} = 2 V, V _{IL} = V _{IL max}	V _O = 2.7 V	20		20	μA	
I _{OZL}	Off-state output current, low-level voltage applied	Q _A - Q _D	V _{CC} = MAX, V _{IH} = 2 V, V _{IL} = V _{IL max}	V _O = 0.4 V	-20		-20	μA	
I _I	Input current at maximum input voltage		V _{CC} = MAX, V _I = 7 V		0.1		0.1	mA	
I _{IH}	High-level input current		V _{CC} = MAX, V _I = 2.7 V		20		20	μA	
I _{IL}	Low-level input current	A, B, C, D	V _{CC} = MAX, V _I = 0.4 V		-0.4		-0.4	mA	
		All others			-0.2		-0.2		
I _{OS}	Short-circuit output current§	Q _A - Q _D	V _{CC} = MAX, V _O = 0 V		-30	-130	-30	-130	mA
		CASC			-20	-100	-20	-100	
I _{CC}	Supply current	All outputs low	V _{CC} = MAX,	See Note 2	35	70	35	70	mA
		All outputs high	All outputs	See Note 3	30	65	30	65	
		Q _A thru Q _D , at Hi-Z	open	See Note 4	37	70	37	70	

† For conditions shown as MIN or MAX, use the appropriate value specified under recommended operating conditions.

‡ All typical values are at V_{CC} = 5 V, T_A = 25°C.

§ Not more than one output should be shorted at a time and duration of the short-circuit should not exceed one second.

- NOTES: 2. I_{CC}L is tested after two 0-V to 4.5 V to 0-V pulses have been applied to SRCK and RCK while S0 is at 4.5 V and all other inputs are grounded.
3. I_{CC}H is tested after two 4.5-V to 0-V to 4.5-V pulses have been applied to SRCK and RCK while all other inputs are at 4.5 V.
4. I_{CC}Z is tested after two 0-V to 4.5-V to 0-V pulses have been applied to SRCK and RCK while S0 and \bar{G} are at 4.5 V and all other inputs are grounded.

3
TTL DEVICES

TYPES SN54LS671, SN54LS672, SN74LS671, SN74LS672

4-BIT UNIVERSAL SHIFT REGISTERS/LATCHES WITH 3-STATE OUTPUTS

switching characteristics, $V_{CC} = 5\text{ V}$, $T_A = 25^\circ\text{C}$, see note 5

PARAMETER	FROM (INPUT)	TO (OUTPUT)	TEST CONDITIONS		'LS671			'LS672			UNIT
			MODE	LOAD	MIN	TYP	MAX	MIN	TYP	MAX	
t_{PLH}	SRCK ↑	CASCADE	SHIFT LEFT OR RIGHT	$R_L = 2\text{ k}\Omega$, $C_L = 15\text{ pF}$	31	45		31	45		ns
t_{PHL}					14	25		14	25		
t_{PLH}	S0, S1		SR CLEAR		11	20		12	20	ns	
t_{PHL}					11	20		12	20		
t_{PHL}	SRCK ↑								19	30	ns
t_{PHL}	SRCLR ↓								19	30	ns
t_{PLH}	SRCK ↑	$Q_A - Q_D$	SHIFT LEFT OR RIGHT	$R_L = 667\ \Omega$, $C_L = 45\text{ pF}$	10	20		10	20		ns
t_{PHL}					16	25		16	25		
t_{PLH}			SR LOAD		10	20		10	20	ns	
t_{PHL}					15	25		15	25		
t_{PHL}			SR CLEAR		17	30		17	30	ns	
t_{PHL}					21	30		21	30		
t_{PLH}	RCK ↑		LATCH		10	20		10	20	ns	
t_{PHL}					15	25		15	25		
t_{PLH}	R/\bar{S} ↑		MUX			12	25		13	25	ns
t_{PHL}						15	25		15	25	
t_{PLH}	R/\bar{S} ↓					17	25		17	25	ns
t_{PHL}						16	25		16	25	
t_{PZH}	\bar{G} ↓	3-STATE ENABLE	16	25		16	25	ns			
t_{PZL}			19	30		19	30				
t_{PHZ}	\bar{G} ↑	3-STATE DISABLE	$R_L = 667\ \Omega$, $C_L = 5\text{ pF}$	16	25		16	25	ns		
t_{PLZ}				16	25		16	25			

NOTE 5: See General Information Section for load circuits and voltage waveforms.

- t_{PLH} ≡ Propagation delay time, low-to-high-level output
- t_{PHL} ≡ Propagation delay time, high-to-low-level output
- t_{PZH} ≡ Output enable time to high level
- t_{PZL} ≡ Output enable time to low level
- t_{PHZ} ≡ Output disable time from high level
- t_{PLZ} ≡ Output disable time from low level

TYPICAL APPLICATION DATA

The 'LS671 or 'LS672 can easily be expanded utilizing the cascade output and the SER L and SER R inputs. A typical expansion is shown below.

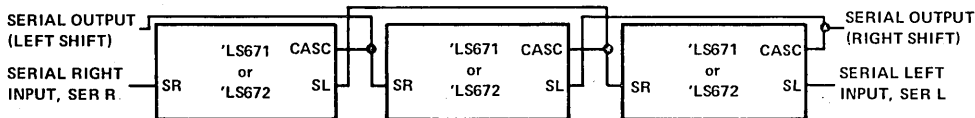

FIGURE 1 — 'LS671, 'LS672 EXPANDED TO 12 BITS, (3 PACKAGES)

Any desired word length may be obtained using the scheme shown. Corresponding control pins of all the packages are tied in common, i.e., all S0 pins are connected together, all S1 pins are connected together, etc.

TYPES SN54LS673, SN54LS674, SN74LS673, SN74LS674 16-BIT SHIFT REGISTERS

D2421, REVISED APRIL 1985

'LS673

- 16-Bit Serial-In, Serial-Out Shift Register with 16-Bit Parallel-Out Storage Register
- Performs Serial-to-Parallel Conversion

'LS674

- 16-Bit Parallel-In, Serial-Out Shift Register
- Performs Parallel-to-Serial Conversion

description

SN54LS673, SN74LS673

The 'LS673 is a 16-bit shift register and a 16-bit storage register in a single 24-pin package. A three-state input/output (SER/Q15) port to the shift register allows serial entry and/or reading of data. The storage register is connected in a parallel data loop with the shift register and may be asynchronously cleared by taking the store-clear input low. The storage register may be parallel loaded with shift-register data to provide shift-register status via the parallel outputs. The shift register can be parallel loaded with the storage-register data upon command.

A high logic level at the chip-level (\overline{CS}) input disables both the shift-register clock and the storage register clock and places SER/Q15 in the high-impedance state. The store-clear function is not disabled by the chip select.

Caution must be exercised to prevent false clocking of either the shift register or the storage register via the chip-select input. The shift clock should be low during the low-to-high transition of chip select and the store clock should be low during the high-to-low transition of chip select.

SN54LS674, SN74LS674

The 'LS674 is a 16-bit parallel-in, serial-out shift register. A three-state input/output (SER/Q15) port provides access for entering a serial data or reading the shift-register word in a recirculating loop.

The device has four basic modes of operation:

- 1) Hold (do nothing)
- 2) Write (serially via input/output)
- 3) Read (serially)
- 4) Load (parallel via data inputs)

Low-to-high-level changes at the chip select input should be made only when the clock input is low to prevent false clocking.

SN54LS673 . . . J OR W PACKAGE SN74LS673 . . . DW, J OR N PACKAGE (TOP VIEW)

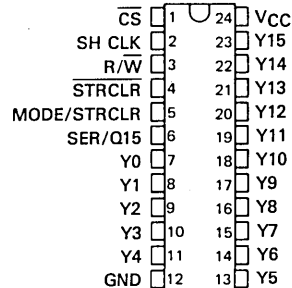

SN54LS673 . . . FK PACKAGE SN74LS673 . . . FN PACKAGE (TOP VIEW)

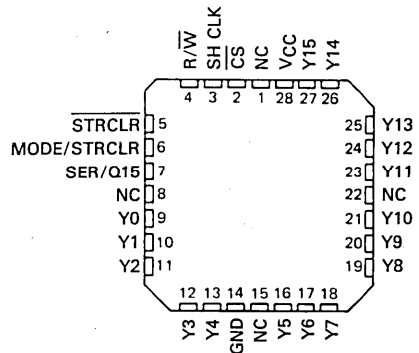

NC—No internal connection



TTL DEVICES

PRODUCTION DATA

This document contains information current as of publication date. Products conform to specifications per the terms of Texas Instruments standard warranty. Production processing does not necessarily include testing of all parameters.

TEXAS
INSTRUMENTS

POST OFFICE BOX 225012 • DALLAS, TEXAS 75265

3-1283

TYPES SN54LS673, SN54LS674, SN74LS673, SN74LS674 16-BIT SHIFT REGISTERS

SN54LS674 ... J OR W PACKAGE
SN74LS674 ... DW, J OR N PACKAGE
(TOP VIEW)

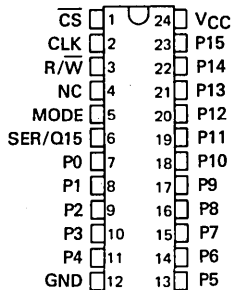

SN54LS674 ... FK PACKAGE
SN74LS674 ... FN PACKAGE
(TOP VIEW)

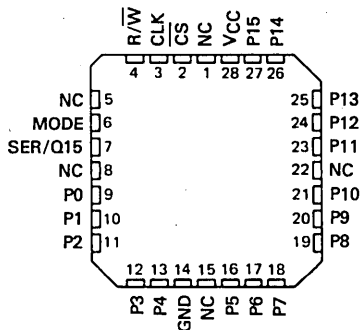

LS673

FUNCTION TABLE

INPUTS					SER/ Q15	SHIFT REGISTER FUNCTIONS				STORAGE REGISTER FUNCTIONS	
CS	R/W	SH CLK	STRCLR	MODE/ STRCLK		SHIFT	READ FROM SERIAL OUTPUT	WRITE INTO SERIAL INPUT	PARALLEL LOAD	CLEAR	LOAD
H	X	X	X	X	Z	NO	NO	NO	NO	NO	NO
X	X	X	L	X						YES	
L	L	↓	X	X	Z	YES	NO	YES	NO		
L	H	X	X	X	Q15		YES	NO			NO
L	H	↓	X	L	Q14n	YES	YES	NO	NO		NO
L	H	↓	L	H	L	NO	YES		YES	YES	NO
L	H	↓	H	H	Y15n	NO	YES		YES	NO	NO
L	L	X	H	↑	Z			NO	NO	NO	YES

LS674 FUNCTION TABLE

INPUTS				SER/ Q15	OPERATION
CS	R/W	MODE	CLK		
H	X	X	X	Z	Do nothing
L	L	X	↓	Z	Shift and write (serial load)
L	H	L	↓	Q14n	Shift and read
L	H	H	↓	P15	Parallel load

H = high level (steady state)

L = low level (steady state)

↑ = transition from low to high level

↓ = transition from high to low level

X = Irrelevant (any input including transitions)

Z = high impedance, input mode

Q14n = content of 14th bit of the shift register before the most recent ↓ transition of the clock.

Q15 = present content of 15th bit of the shift register

Y15n = content of the 15th bit of the storage register before the most recent ↓ transition of the clock.

P15 = level of input P15

TYPES SN54LS673, SN54LS674, SN74LS673, SN74LS674 16-BIT SHIFT REGISTERS

logic symbols

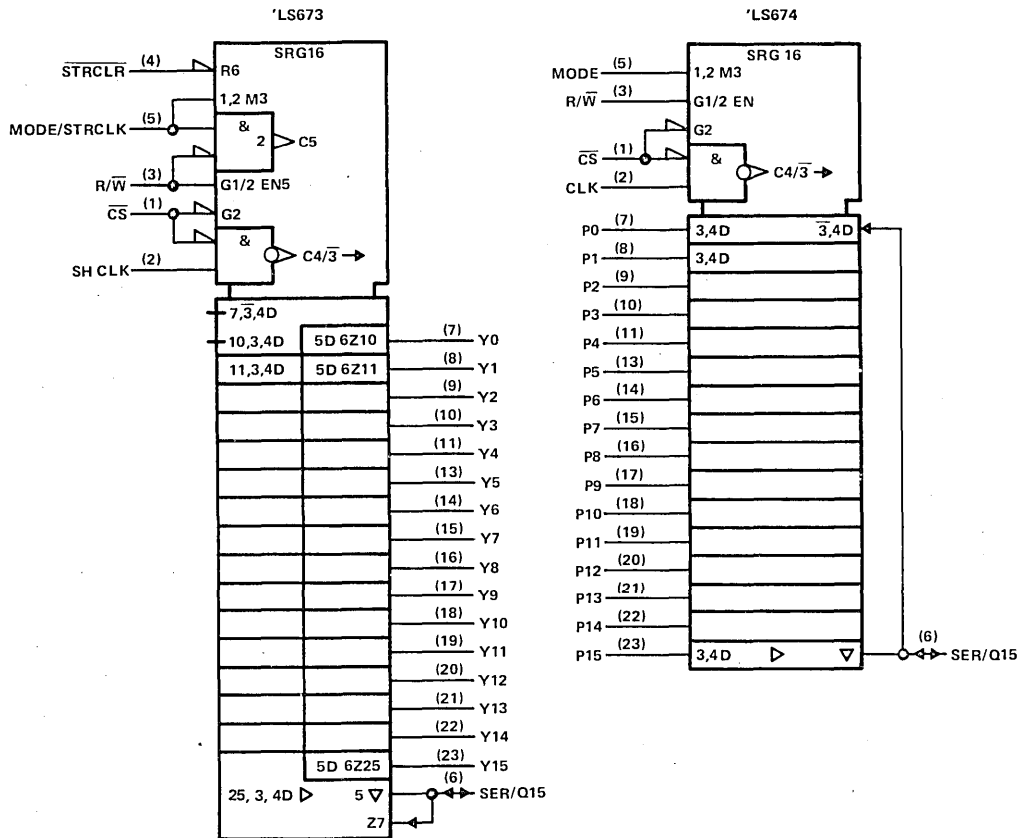

Pin numbers shown on logic notation are for DW, J or N packages.



TTL DEVICES

TYPES SN54LS673, SN54LS674, SN74LS673, SN74LS674

16-BIT SHIFT REGISTERS

functional block diagrams

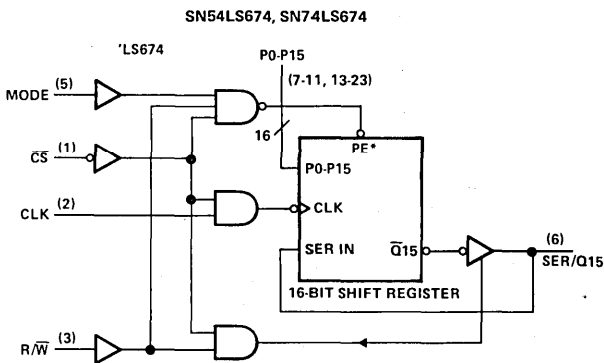
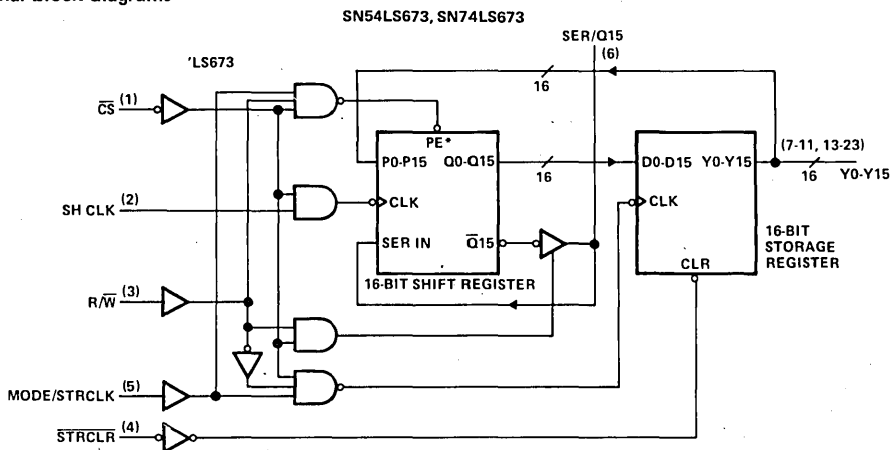

*When PE is active, data is synchronously parallel loaded into the shift registers from the 16 P inputs and no shifting takes place. Pin numbers shown on logic notation are for DW, J or N packages.

3

TTL DEVICES

TYPES SN54LS673, SN54LS674, SN74LS673, SN74LS674 16-BIT SHIFT REGISTERS

schematics of inputs and outputs

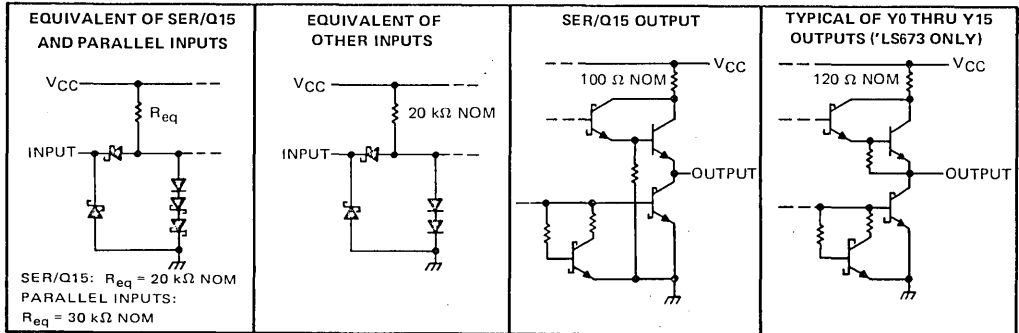

absolute maximum ratings over operating free-air temperature range (unless otherwise noted)

Supply voltage, V_{CC} (see Note 1)	7 V
Input voltage: SER/Q15	5.5 V
All others	7 V
Off-state output voltage	5.5 V
Operating free-air temperature range: SN54LS673, SN54LS674	-55°C to 125°C
SN74LS673, SN74LS674	0°C to 70°C
Storage temperature range	-65°C to 150°C

NOTE 1. Voltage values are with respect to network ground terminal.

recommended operating conditions

			SN54LS'			SN74LS'			UNIT
			MIN	NOM	MAX	MIN	NOM	MAX	
V_{CC}	Supply voltage		4.5	5	5.5	4.75	5	5.25	V
I_{OH}	High-level output current	SER/Q15			-1			-2.6	mA
		Y0 thru Y15			-0.4		-0.4		
I_{OL}	Low-level output current	SER/Q15			12			24	mA
		Y0 thru Y15			4		8		
f_{clock}	Clock frequency		0		20	0		20	MHz
$t_{w(clock)}$	Width of clock input pulse		20			20			ns
$t_{w(clear)}$	Width of clear input pulse		20			20			ns
t_{su}	Setup time	SER/Q15			20			20	ns
		P0 thru P15			20		20		
		Mode			35		35		
		R/W, \overline{CS}			35		35		
		SH CLK ↓ to Mode/STR CLK ↑ See Note 2			25		25		
t_h	Hold time	SER/Q15			0			0	ns
		P0 thru P15	'LS673			0		0	
			'LS674			5.0		5.0	
		Mode			0		0		
T_A	Operating free-air temperature		-55		125	0		70	°C

NOTE 2: This setup time ensures the storage register will see stable data from the shift register.



TTL DEVICES

TYPES SN54LS673, SN54LS674, SN74LS673, SN74LS674 16-BIT SHIFT REGISTERS

electrical characteristics over recommended operating free-air temperature range (unless otherwise noted)

PARAMETER		TEST CONDITIONS†	SN54LS'			SN74LS'			UNIT	
			MIN	TYP‡	MAX	MIN	TYP‡	MAX		
V _{IH}	High-level input voltage		2			2			V	
V _{IL}	Low-level input voltage		0.7			0.8			V	
V _{IK}	Input clamp voltage	V _{CC} = MIN, I _I = -18 mA	-1.5			-1.5			V	
V _{OH}	High-level output voltage	SER/Q15	V _{CC} = MIN, V _{IH} = 2 V, I _{OH} = MAX			2.4	3.2	2.4	3.1	V
		Y0 thru Y15¶	V _{IL} = V _{ILmax}			2.5	3.4	2.7	3.4	
V _{OL}	Low-level output voltage	SER/Q15	V _{CC} = MIN, V _{IH} = 2 V, V _{IL} = V _{ILmax}	I _{OL} = 12 mA	0.25	0.4	0.25	0.4	V	
				I _{OL} = 24 mA			0.35	0.5		
		Y0 thru Y15¶	V _{CC} = MAX, V _{IH} = 2 V, V _{IL} = V _{ILmax}	I _{OL} = 4 mA	0.25	0.4	0.25	0.4		
				I _{OL} = 8 mA			0.35	0.5		
I _{OZH}	Off-state output current, high-level voltage applied	SER/Q15	V _{CC} = MAX, V _{IH} = 2 V, V _{IL} = V _{ILmax} , V _O = 2.7 V	40			40	μA		
I _{OZL}	Off-state output current, low-level voltage applied	SER/Q15	V _{CC} = MAX, V _{IH} = 2 V, V _{IL} = V _{ILmax} , V _O = 0.4 V	-0.4			-0.4	mA		
I _I	Input current at maximum input voltage	SER/Q15	V _{CC} = MAX	V _I = 5.5 V	0.1			0.1	mA	
		Others		V _I = 7 V	0.1			0.1		
I _{IH}	High-level input current	SER/Q15	V _{CC} = MAX, V _I = 2.7 V	40			40	μA		
		Others			20				20	
I _{IL}	Low-level input current		V _{CC} = MAX, V _I = 0.4 V	-0.4			-0.4	mA		
I _{OS}	Short-circuit output current§	SER/Q15	V _{CC} = MAX	-30	-130	-30	-130	mA		
		Y0 thru Y15¶		-20	-100	-20	-100			
I _{CC}	Supply current	'LS673	V _{CC} = MAX	50	80	52	80	mA		
		'LS674		25	40	25	40			

† For conditions shown as MIN or MAX use the appropriate value specified under recommended operating conditions.

‡ All typical values are at V_{CC} = 5 V, T_A = 25°C.

§ Not more than one output should be shorted at a time, and duration of the short circuit should not exceed one second.

¶ 'LS673 only.

switching characteristics, V_{CC} = 5 V, T_A = 25°C, see note 2 :

PARAMETER	'LS673		'LS674		TEST CONDITIONS	MIN	TYP	MAX	UNIT
	FROM	TO	FROM	TO					
f _{max}	SH CLK	SER/Q15	CLK	SER/Q15	R _L = 667 Ω, C _L = 45 pF	20	28		MHz
t _{PHL}	STRCLR	Y0 thru Y15			R _L = 2 kΩ, C _L = 15 pF		25	40	ns
t _{PLH}	MODE/	Y0 thru Y15				28	45		
t _{PHL}	STRCLK					30	45		
t _{PLH}	SH CLK		SER/Q15	CLK		SER/Q15	R _L = 667 Ω, C _L = 45 pF	21	
t _{PHL}						26	40	ns	
t _{PZH}	CS, R/W	SER/Q15	CS, R/W	SER/Q15	R _L = 667 Ω, C _L = 45 pF	30	45	ns	
t _{PZL}						30	45		
t _{PHZ}	CS, R/W	SER/Q15	CS, R/W	SER/Q15	R _L = 667 Ω, C _L = 5 pF	25	40	ns	
t _{PLZ}							25		40

NOTE 2: See General Information Section for load circuits and voltage waveforms.

f_{max} ≡ maximum clock frequency

t_{PLH} ≡ Propagation delay time, low-to-high-level output

t_{PHL} ≡ Propagation delay time, high-to-low-level output

t_{PZH} ≡ Output enable time to high level

t_{PZL} ≡ Output enable time to low level

t_{PHZ} ≡ Output disable time from low level

t_{PLZ} ≡ Output disable time from high level

3

TTL DEVICES

TYPES SN54LS681, SN74LS681 4-BIT PARALLEL BINARY ACCUMULATORS

D2422, JANUARY 1981—REVISED APRIL 1985

- Full 4-Bit Binary Accumulator in a Single 20-Pin Package
- Contains Two Synchronous Registers:
Word A
Word B Shift/Accumulator
- 16 Arithmetic Operations Including
B Minus A and A Minus B
- 16 Logic-Mode Operations
- Expandable to Handle N-Bit Words
with Full Carry Look-Ahead
- Bus Driving I/O Ports

description

These low-power Schottky IC's integrate a high-speed arithmetic logic unit (ALU) complete with word A and word B registers on a single chip. The ALU performs 16 arithmetic and 16 logic functions (see Tables 1 and 2). Full carry look-ahead is provided for fast carry of four-bit words. The carry input (C_n) and propagate and generate outputs (\bar{P} and \bar{G}) are provided for direct use with SN54S182/SN74S182 carry look-ahead generators for optimum performance with longer words.

The A and B registers are controlled by three inputs (RS0, RS1, and RS2). These pins define eight distinct register modes (see Table 3). The A register is a simple storage register while the B register is a combination storage/shift/accumulator register. The contents of the A and B registers provide the A and B words for the ALU.

Four I/O ports (I/O 0 thru I/O 3) are provided for parallel loading of word A and/or word B into their respective registers. These same ports also serve as bus driving outputs for the ALU/accumulator results (F). Two additional I/O ports (RI/LO and LI/RO) are provided to allow expansion of the accumulator for words greater than four bits in length.

The A or B register can be parallel loaded from the four I/O ports. The B register can also be parallel loaded from the ALU as an accumulator register and in addition, the B register can be serially loaded from either the RI/LO or the LI/RO ports.

The SN54LS681 is characterized for operation over the full military temperature range from -55°C to 125°C . The SN74LS681 is characterized for operation from 0°C to 70°C .

SN54LS681 ... J PACKAGE
SN74LS681 ... DW, J OR N PACKAGE

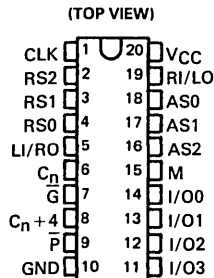

SN54LS681 ... FK PACKAGE
SN74LS681 ... FN PACKAGE

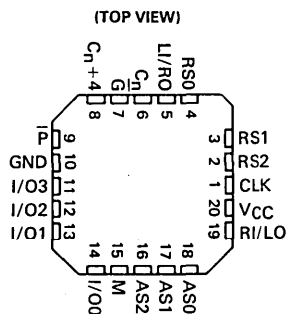

PRODUCTION DATA
This document contains information current as of publication date. Products conform to specifications per the terms of Texas Instruments standard warranty. Production processing does not necessarily include testing of all parameters.

**TEXAS
INSTRUMENTS**

POST OFFICE BOX 225012 • DALLAS, TEXAS 75265

3-1289

3

TTL DEVICES

TYPES SN54LS681, SN74LS681 4-BIT PARALLEL BINARY ACCUMULATORS

functional block diagram

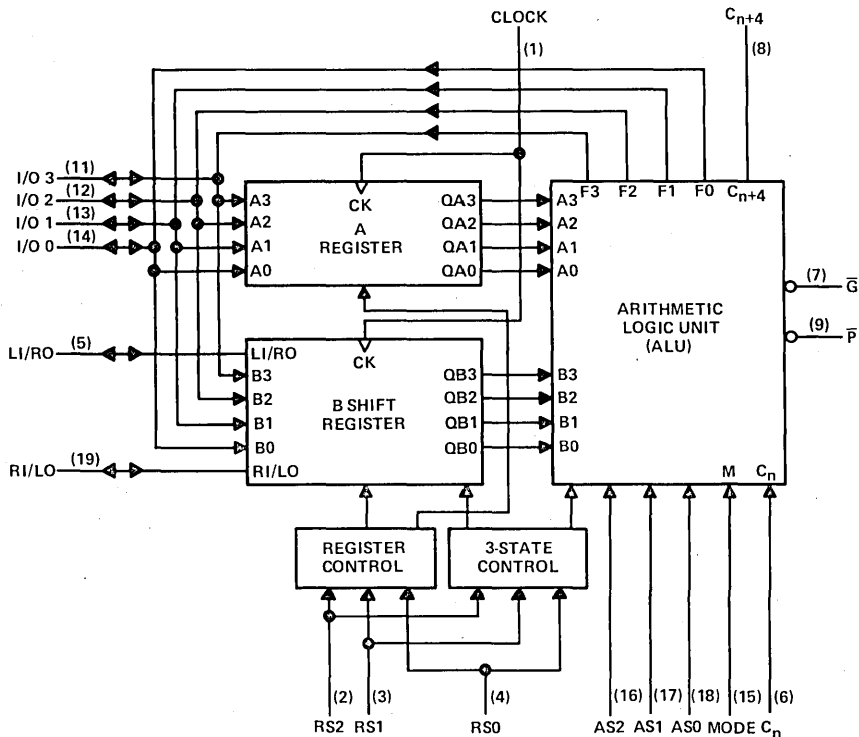

schematics of inputs and outputs

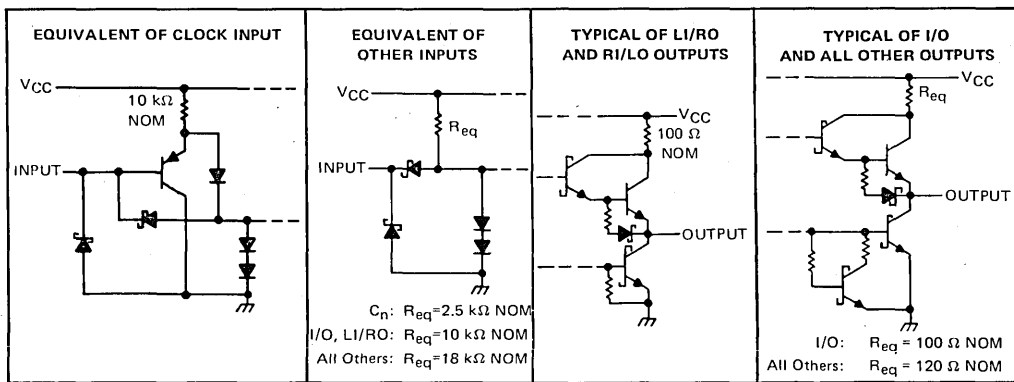

3

TTL DEVICES

TYPES SN54LS681, SN74LS681 4-BIT PARALLEL BINARY ACCUMULATORS

FUNCTION TABLES

TABLE 1 — ARITHMETIC FUNCTIONS

Mode Control (M) = Low

ALU SELECTION	ACTIVE-HIGH DATA					
	C _n = H (with carry)			C _n = L (no carry)		
AS2 AS1 AS0						
L L L	F _j = L			F _j = H		
L L H	F = B MINUS A			F = B MINUS A MINUS 1		
L H L	F = A MINUS B			F = A MINUS B MINUS 1		
L H H	F = A PLUS B PLUS 1			F = A PLUS B		
H L L	F = B PLUS 1			F _j = B _j		
H L H	F = \bar{B} PLUS 1			F _j = \bar{B}_j		
H H L	F = A PLUS 1			F _j = A _j		
H H H	F = \bar{A} PLUS 1			F _j = \bar{A}_j		

TABLE 2 — LOGIC FUNCTIONS

Mode Control (M) = High

ALU SELECTION	ACTIVE-HIGH DATA					
	C _n = H (with carry)			C _n = L (no carry)		
AS2 AS1 AS0						
L L L	F ₀ = H, F ₁ = F ₂ = F ₃ = L			F _j = L		
L L H	F _j = A _j ⊕ B _j PLUS 1			F _j = A _j ⊕ B _j		
L H L	F _j = A _j ⊕ B _j PLUS 1			F _j = A _j ⊕ B _j		
L H H	F _j = L			F _j = H		
H L L	F _j = A _j B _j PLUS 1			F _j = A _j B _j		
H L H	F _j = A _j + B _j PLUS 1			F _j = A _j + B _j		
H H L	F _j = $\overline{A_j B_j}$ PLUS 1			F _j = $\overline{A_j B_j}$		
H H H	F _j = A _j + B _j PLUS 1			F _j = A _j + B _j		

TABLE 3 — REGISTER FUNCTIONS

FUNCTION	INPUTS BEFORE L TO H CLOCK TRANSITION										INTERNAL OUTPUTS AFTER L TO H CLOCK TRANSITION													
	REGISTER SELECTION			DATA INPUTS							A REGISTER				B SHIFT REGISTER						ALU			
	RS2 RS1 RS0	LI/RO	I/O 3	I/O 2	I/O 1	I/O 0	RI/LO	QA3	QA2	QA1	QA0	LI/RO	QB3	QB2	QB1	QB0	RI/LO	F3	F2	F1	F0			
ACCUM	L L L	Z	F3	F2	F1	F0	Z	QA3 ₀	QA2 ₀	QA1 ₀	QA0 ₀	Z	F3 _n	F2 _n	F1 _n	F0 _n	Z	F3	F2	F1	F0			
LOAD B	L L H	Z	b3	b2	b1	b0	Z	QA3 ₀	QA2 ₀	QA1 ₀	QA0 ₀	Z	b3	b2	b1	b0	Z	Z	Z	Z	Z			
LEFT SHIFT LOGICAL	L H L	li	F3	F2	F1	F0	QB0	QA3 ₀	QA2 ₀	QA1 ₀	QA0 ₀	li	li	QB3 _n	QB2 _n	QB1 _n	QB1 _n	F3	F2	F1	F0			
LEFT SHIFT ARITH	L H H	li	F3	F2	F1	F0	QB0	QA3 ₀	QA2 ₀	QA1 ₀	QA0 ₀	li	QB3 _n	li	QB2 _n	QB1 _n	QB1 _n	F3	F2	F1	F0			
RIGHT SHIFT LOGICAL	H L L	QB3	F3	F2	F1	F0	ri	QA3 ₀	QA2 ₀	QA1 ₀	QA0 ₀	QB2 _n	QB2 _n	QB1 _n	QB0 _n	ri	ri	F3	F2	F1	F0			
RIGHT SHIFT ARITH	H L H	QB2	F3	F2	F1	F0	ri	QA3 ₀	QA2 ₀	QA1 ₀	QA0 ₀	QB1 _n	QB3 _n	QB1 _n	QB0 _n	ri	ri	F3	F2	F1	F0			
HOLD	H H L	Z	F3	F2	F1	F0	Z	QA3 ₀	QA2 ₀	QA1 ₀	QA0 ₀	Z	QB3 ₀	QB2 ₀	QB1 ₀	QB0 ₀	Z	F3 ₀	F2 ₀	F1 ₀	F0 ₀			
LOAD A	H H H	Z	a3	a2	a1	a0	Z	a3	a2	a1	a0	Z	QB3 ₀	QB2 ₀	QB1 ₀	QB0 ₀	Z	Z	Z	Z	Z			

H = high level (steady state)

L = low level (steady state)

Z = high impedance (output off)

a₀ ... a₃, b₀ ... b₃ = the level of steady-state condition at I/O 0 thru I/O 3, respectively and intended as A or B input data

F₀ ... F₃ = internal ALU results

QA₀ ... QB₀, F₀ ... F₃ = the level of QA₀ thru QB₃ and F₀ thru F₃, respectively, before the indicated steady-state input conditions were established

QA_{0n} ... QB_{3n} = the level of QA₀ thru QB₃ before the most recent ↑ transition of the clock

ri, li = the level of steady-state conditions at RI/LO or LI/RO, respectively

3
TTL DEVICES

TYPES SN54LS681, SN74LS681 4-BIT PARALLEL BINARY ACCUMULATORS

logic symbol

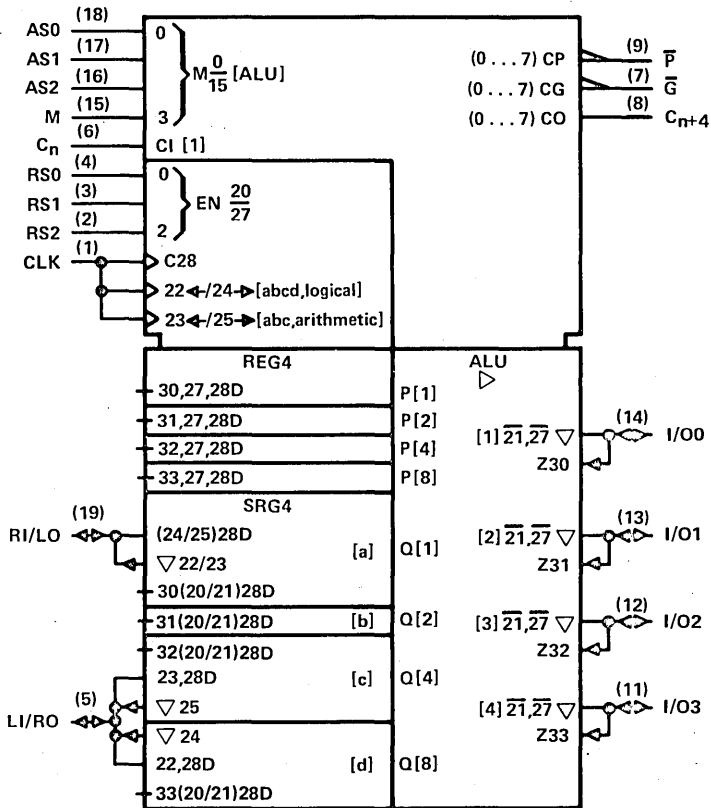

Pin numbers shown on logic notation are for DW, J or N packages.

absolute maximum ratings over operating free-air temperature range (unless otherwise noted)

Supply voltage, V_{CC} (see Note 1)	7 V
Input voltage	7 V
Operating free-air temperature range: SN54LS681	-55°C to 125°C
SN74LS681	0°C to 70°C
Storage temperature range	-65°C to 150°C

NOTE 1: Voltage values are with respect to the network ground terminal.

3

TTL DEVICES

TYPES SN54LS681, SN74LS681 4-BIT PARALLEL BINARY ACCUMULATORS

recommended operating conditions

		SN54LS681			SN74LS681			UNIT
		MIN	NOM	MAX	MIN	NOM	MAX	
Supply voltage, V_{CC}		4.5	5	5.5	4.75	5	5.25	V
High-level output current, I_{OH}	LI/RO, I/O, RI/LO	-1			-2.6			mA
	$\bar{P}, \bar{G}, C_{n+4}$	-0.4			-0.4			mA
Low-level output current, I_{OL}	I/O	12			24			mA
	$C_{n+4}, LI/RO, RI/LO$	4			8			
	\bar{P}	8			8			
	\bar{G}	16			16			
Clock frequency, f_{clock}		0	20		0	20		MHz
Width of clock pulse, $t_w(\text{clock})$		25			25			ns
Setup time, t_{su}	RS0-RS2 to CLK†	30			30			ns
	Data I/O to CLK†	25			25			
Hold time, t_h		0			0			ns
Operating free-air temperature, T_A		-55			125		70	°C

electrical characteristics over recommended operating free-air temperature range (unless otherwise noted)

PARAMETER		TEST CONDITIONS†		SN54LS681		SN74LS681		UNIT	
				MIN	TYP‡	MAX	MIN		TYP‡
V_{IH}	High-level input voltage			2		2		V	
V_{IL}	Low-level input voltage	C_n			0.7		0.7	V	
		All others			0.7		0.8	V	
V_{IK}	Input clamp voltage	$V_{CC}=\text{MIN}, I_I=-18 \text{ mA}$			-1.5		-1.5	V	
V_{OH}	High-level output voltage	All I/O	$V_{CC}=\text{MIN}, V_{IH}=2 \text{ V}, V_{IL}=V_{IL \text{ max}}, I_{OH}=\text{MAX}$	2.4	3.1	2.4	3.2	V	
		$\bar{P}, \bar{G}, C_{n+4}$		2.5	3.4	2.7	3.4		
V_{OL}	Low-level output voltage	I/O	$V_{CC}=\text{MAX}, V_{IH}=2 \text{ V}, V_{IL}=V_{IL \text{ max}}$	$I_{OL}=12 \text{ mA}$	0.25	0.4	0.25	0.4	V
				$I_{OL}=24 \text{ mA}$			0.35	0.5	
		$LI/RO, RI/LO, C_{n+4}$		0.25	0.4	0.25	0.4		
		$I_{OL}=8 \text{ mA}$				0.35	0.5		
		$I_{OL}=8 \text{ mA}$		0.35	0.5	0.35	0.5		
\bar{G}	$I_{OL}=16 \text{ mA}$	0.35	0.5	0.35	0.5				
I_{OZH}	Off-state output current, high-level voltage applied	I/O, LI/RO, RI/LO	$V_{CC}=\text{MAX}, V_{IH}=2 \text{ V}, V_{OL}=2.7 \text{ V}$		40		40	μA	
I_{OZL}	Off-state output current, low-level voltage applied	I/O, LI/RO	$V_{CC}=\text{MAX}, V_{IH}=2 \text{ V}, V_{OL}=0.4 \text{ V}$	-0.8		-0.8		mA	
		RI/LO		-0.4		-0.4			
I_I	Input current at maximum input voltage	All I/O	$V_{CC}=\text{MAX}$	$V_I=5.5 \text{ V}$	0.1		0.1	mA	
		C_n		$V_I=7 \text{ V}$	0.5		0.5		
		All others			0.1		0.1		
I_{IH}	High-level input current	C_n	$V_{CC}=\text{MAX}, V_I=2.7 \text{ V}$		100		100	μA	
		All I/O			40		40		
		All others			20		20		
I_{IL}	Low-level input current	C_n	$V_{CC}=\text{MAX}, V_I=0.4 \text{ V}$		-4		-4	mA	
		I/O, LI/RO			-0.8		-0.8		
		CLK			-0.2		-0.2		
		All others			-0.4		-0.4		
I_{OS}	Short-circuit output current §	I/O	$V_{CC}=\text{MAX}$	-30	-130	-30	-130	mA	
		$LI/RO, RI/LO, \bar{P}, \bar{G}, C_{n+4}$		-20	-100	-20	-100		
I_{CC}	Supply current	$V_{CC}=\text{MAX}, \text{RS0 at } 4.5 \text{ V, All other I/O at } 0 \text{ V}$		100	150	100	150	mA	

†For conditions shown as MIN or MAX, use the appropriate value specified under recommended operations.

‡All typical values are at $V_{CC} = 5 \text{ V}, T_A = 25^\circ\text{C}$.

§Not more than one output should be shorted at a time, and duration of the short-circuit should not exceed one second.

TYPES SN54LS681, SN74LS681

4-BIT PARALLEL BINARY ACCUMULATORS

switching characteristics, $V_{CC} = 5\text{ V}$, $T_A = 25^\circ\text{C}$

PARAMETER †	FROM (INPUT)	TO (OUTPUT)	TEST CONDITIONS		MIN	TYP	MAX	UNIT								
t_{PLH}	CLOCK †	\bar{P}	$R_L = 667\ \Omega$, $C_L = 45\ \text{pF}$		25	40	ns									
t_{PHL}					30	45										
t_{PLH}		\bar{G}			$R_L = 2\ \text{k}\Omega$, $C_L = 15\ \text{pF}$		26	40	ns							
t_{PHL}							27	40								
t_{PLH}		I/O							27	40	ns					
t_{PHL}									29	40						
t_{PLH}		C_n+4									36	55	ns			
t_{PHL}											34	50				
t_{PLH}		LI/RO											25	40	ns	
t_{PHL}													23	35		
t_{PLH}	RI/LO			19									30	ns		
t_{PHL}				17									30			
t_{PLH}	AS0-AS2			\bar{P}	$R_L = 667\ \Omega$, $C_L = 45\ \text{pF}$								30	45	ns	
t_{PHL}													30	45		
t_{PLH}				\bar{G}									27	35	ns	
t_{PHL}													28	35		
t_{PLH}				I/O									31	45	ns	
t_{PHL}													29	45		
t_{PLH}				C_n+4									39	55	ns	
t_{PHL}													34	50		
t_{PLH}		C_n	\bar{P}	$R_L = 667\ \Omega$, $C_L = 45\ \text{pF}$										9	25	ns
t_{PHL}														9	20	
t_{PLH}	I/O					17								35	ns	
t_{PHL}						13								20		
t_{PLH}	C_n+4							20						30	ns	
t_{PHL}								16						25		
t_{PLH}	MODE							\bar{P}	$R_L = 667\ \Omega$, $C_L = 45\ \text{pF}$					28	40	ns
t_{PHL}														29	40	
t_{PLH}								\bar{G}						21	30	ns
t_{PHL}														23	30	
t_{PLH}		I/O											30	45	ns	
t_{PHL}													28	40		
t_{PLH}		C_n+4											40	60	ns	
t_{PHL}													37	50		
t_{PZH}		RS0-RS2				I/O	$R_L = 667\ \Omega$						$C_L = 45\ \text{pF}$	28	45	ns
t_{PZL}														28	45	
t_{PHZ}										$C_L = 5\ \text{pF}$			35	65	ns	
t_{PLZ}													39	65		
t_{PZH}						LI/RO				$R_L = 2\ \text{k}\Omega$		$C_L = 15\ \text{pF}$	25	40	ns	
t_{PZL}													22	40		
t_{PHZ}												$C_L = 5\ \text{pF}$	21	40	ns	
t_{PLZ}													34	60		
t_{PZH}			RI/LO									$C_L = 15\ \text{pF}$	22	40	ns	
t_{PZL}													24	40		
t_{PHZ}												$C_L = 5\ \text{pF}$	11	30	ns	
t_{PLZ}													16	40		

† t_{PLH} = Propagation delay time, low-to-high-level input
 † t_{PHL} = Propagation delay time, high-to-low-level input
 † t_{PZL} = Output enable time to low level

† t_{PZH} = Output enable time to high level
 † t_{PLZ} = Output disable time from low level
 † t_{PHZ} = Output disable time from high level

NOTE 2: See General Information Section for load circuits and voltage waveforms.

TTL DEVICES

TYPES SN54LS682 THRU SN54LS689, SN74LS682 THRU SN74LS689 8-BIT MAGNITUDE/IDENTITY COMPARATORS

D2617, JANUARY 1981—REVISED DECEMBER 1983

- Compares Two 8-Bit Words
- Choice of Totem-Pole or Open-Collector Outputs
- Hysteresis at P and Q Inputs
- 'LS682 and 'LS683 have 20-k Ω Pullup Resistors on the Q Inputs
- 'LS686 and 'LS687 . . . New JT and NT 24-Pin, 3000-Mil Packages

TYPE	P=Q	P>Q	OUTPUT ENABLE	OUTPUT CONFIGURATION	20-k Ω PULLUP
'LS682	yes	yes	no	totem-pole	yes
'LS683	yes	yes	no	open-collector	yes
'LS684	yes	yes	no	totem-pole	no
'LS685	yes	yes	no	open-collector	no
'LS686	yes	yes	yes	totem-pole	no
'LS687	yes	yes	yes	open-collector	no
'LS688	yes	no	yes	totem-pole	no
'LS689	yes	no	yes	open-collector	no

SN54LS686, SN54LS687 . . . JT PACKAGE
SN74LS686, SN74LS687 . . . DW, JT OR NT PACKAGE
(TOP VIEW)

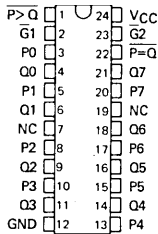

SN54LS686, SN54LS687 . . . FK PACKAGE
SN74LS686, SN74LS687 . . . FN PACKAGE
(TOP VIEW)

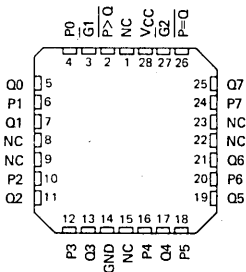

NC - No internal connection

SN54LS682 THRU SN54LS685 . . . J PACKAGE
SN74LS682 THRU SN74LS685 . . . DW, J OR N PACKAGE
(TOP VIEW)

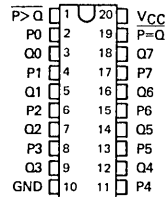

SN54LS682 THRU SN54LS685 . . . FK PACKAGE
SN74LS682 THRU SN74LS685 . . . FN PACKAGE
(TOP VIEW)

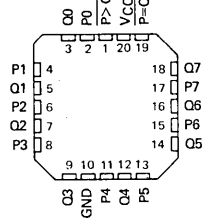

SN54LS688, SN54LS689 . . . J PACKAGE
SN74LS688, SN74LS689 . . . DW, J OR N PACKAGE
(TOP VIEW)

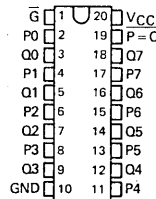

SN54LS688, SN54LS689 . . . FK PACKAGE
SN74LS688, SN74LS689 . . . FN PACKAGE
(TOP VIEW)

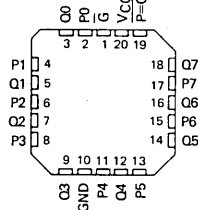

PRODUCTION DATA
This document contains information current as of publication date. Products conform to specifications per the terms of Texas Instruments standard warranty. Production processing does not necessarily include testing of all parameters.

TEXAS INSTRUMENTS

POST OFFICE BOX 225012 • DALLAS, TEXAS 75265



TTL DEVICES

TYPES SN54LS682 THRU SN54LS689, SN74LS682 THRU SN74LS689 8-BIT MAGNITUDE/IDENTITY COMPARATORS

description

These magnitude comparators perform comparisons of two eight-bit binary or BCD words. All types provide $\overline{P = Q}$ outputs and the 'LS682 thru 'LS687 provide $\overline{P > Q}$ outputs as well. The 'LS682, 'LS684, 'LS686, and 'LS688 have totem-pole outputs, while the 'LS683, 'LS685, 'LS687, and 'LS689 have open-collector outputs. The 'LS682 and 'LS683 feature 20-k Ω pullup termination resistors on the Q inputs for analog or switch data.

FUNCTION TABLE

DATA P, Q	INPUTS ENABLES		OUTPUTS	
	$\overline{G}, \overline{G1}$	$\overline{G2}$	$\overline{P = Q}$	$\overline{P > Q}$
P = Q	L	X	L	H
P > Q	X	L	H	L
P < Q	X	X	H	H
P = Q	H	X	H	H
P > Q	X	H	H	H
X	H	H	H	H

- NOTES:
1. The last three lines of the function table applies only to the devices having enable inputs, i.e., 'LS686 thru 'LS689.
 2. The $P < Q$ function can be generated by applying the $P = Q$ and $P > Q$ outputs to a 2-input NAND gate.
 3. For 'LS686, 'LS687 G1 enables $P = Q$, and G2 enables $P > Q$.

logic symbols

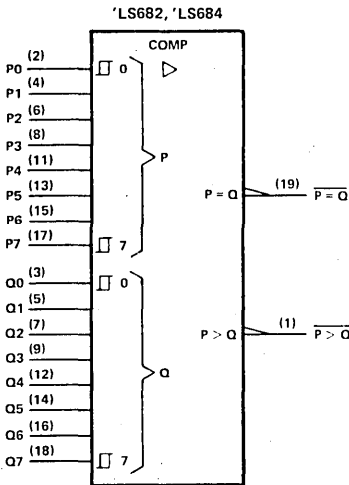

Pin numbers shown on logic notation are for DW, J, JT, N or NT packages.

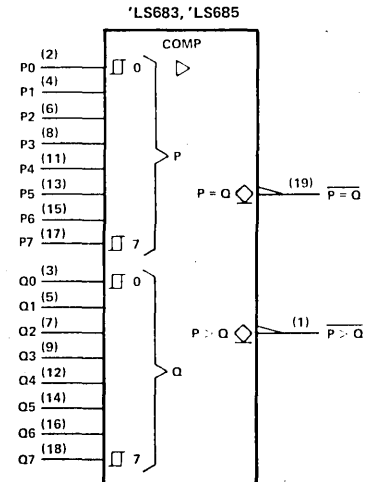
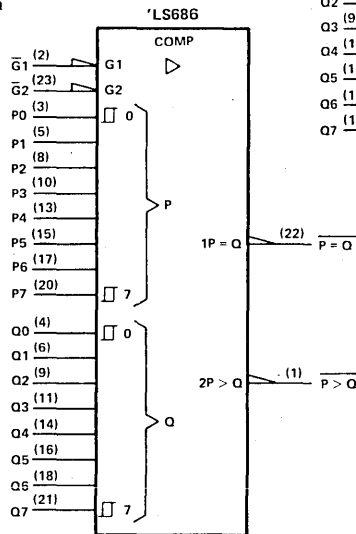

3 TTL DEVICES

TYPES SN54LS682 THRU SN54LS689, SN74LS682 THRU SN74LS689 8-BIT MAGNITUDE/IDENTITY COMPARATORS

logic symbols (continued)

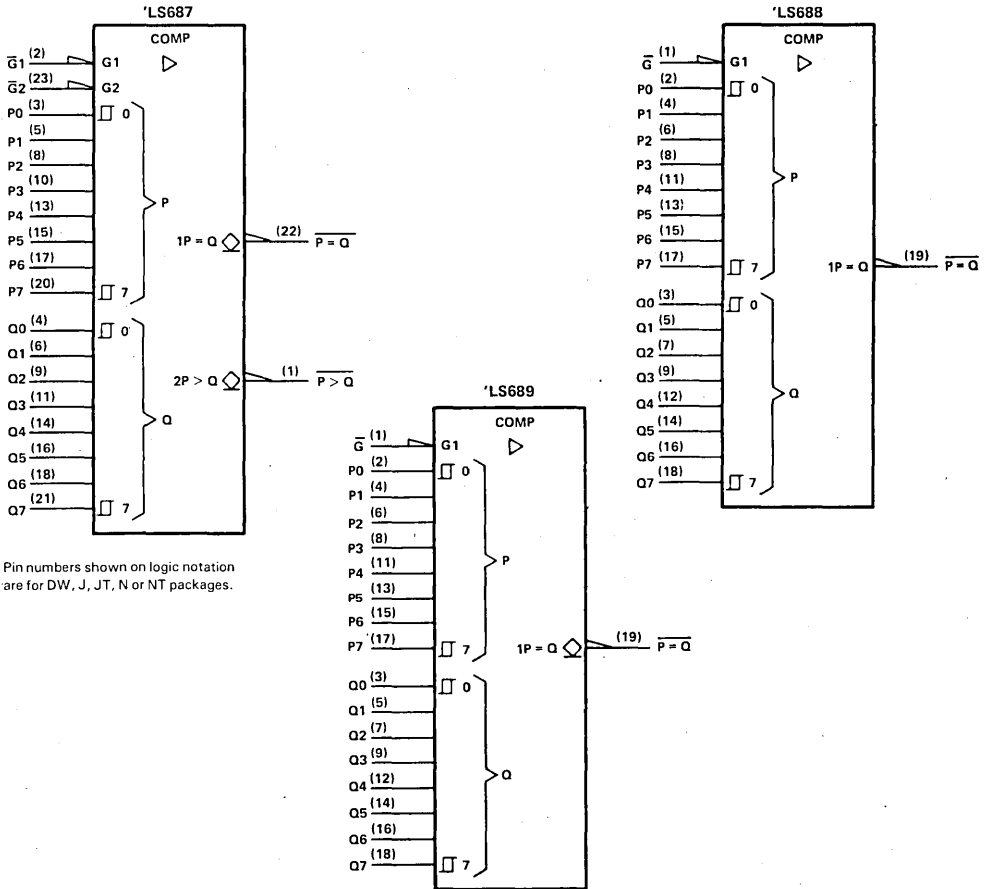

Pin numbers shown on logic notation are for DW, J, JT, N or NT packages.

schematics of inputs and outputs

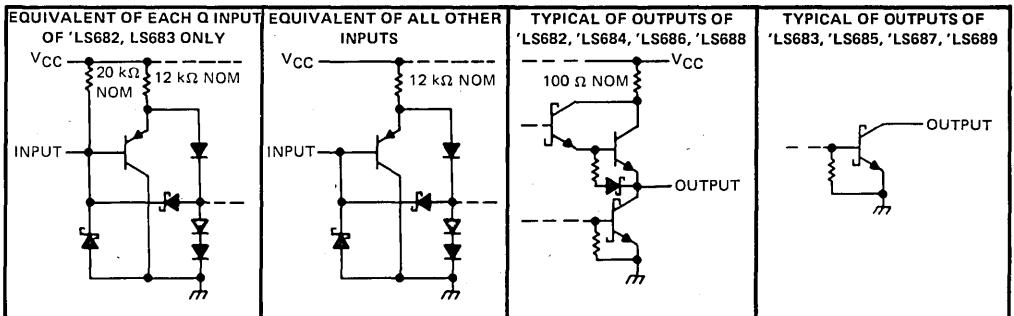

TYPES SN54LS682 THRU SN54LS685
 SN74LS682 THRU SN74LS685
 8-BIT MAGNITUDE/IDENTITY COMPARATORS

'LS682 thru 'LS685 logic diagram (positive logic)

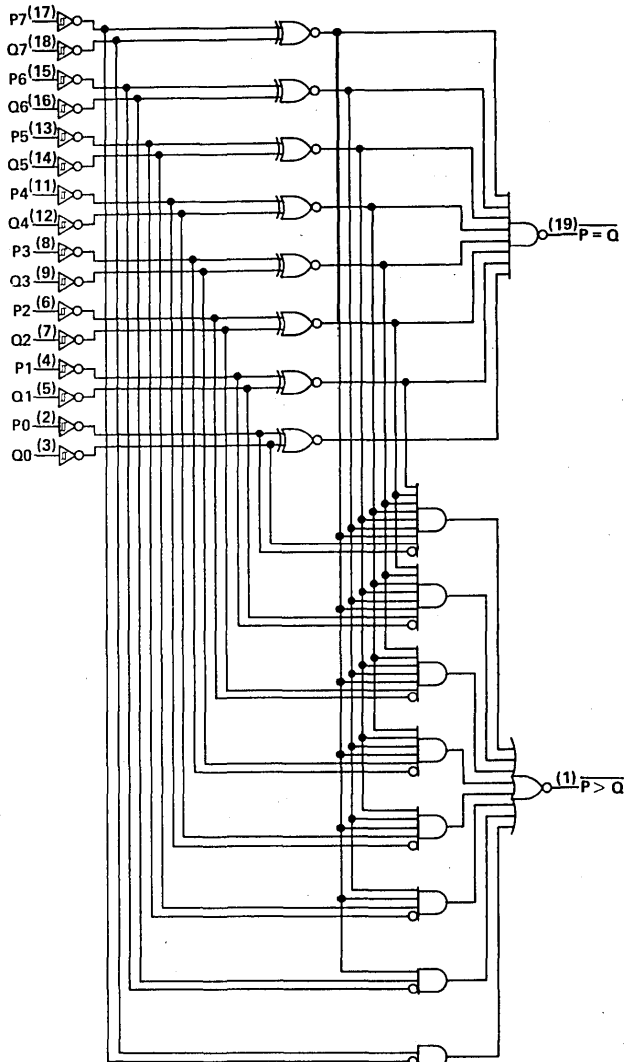

Pin numbers shown on logic notation are for DW, J or N packages

3

TTL DEVICES

TYPES SN54LS686, SN54LS687
 SN74LS686, SN74LS687
 8-BIT MAGNITUDE/IDENTITY COMPARATORS

'LS686, 'LS687 logic diagram (positive logic)

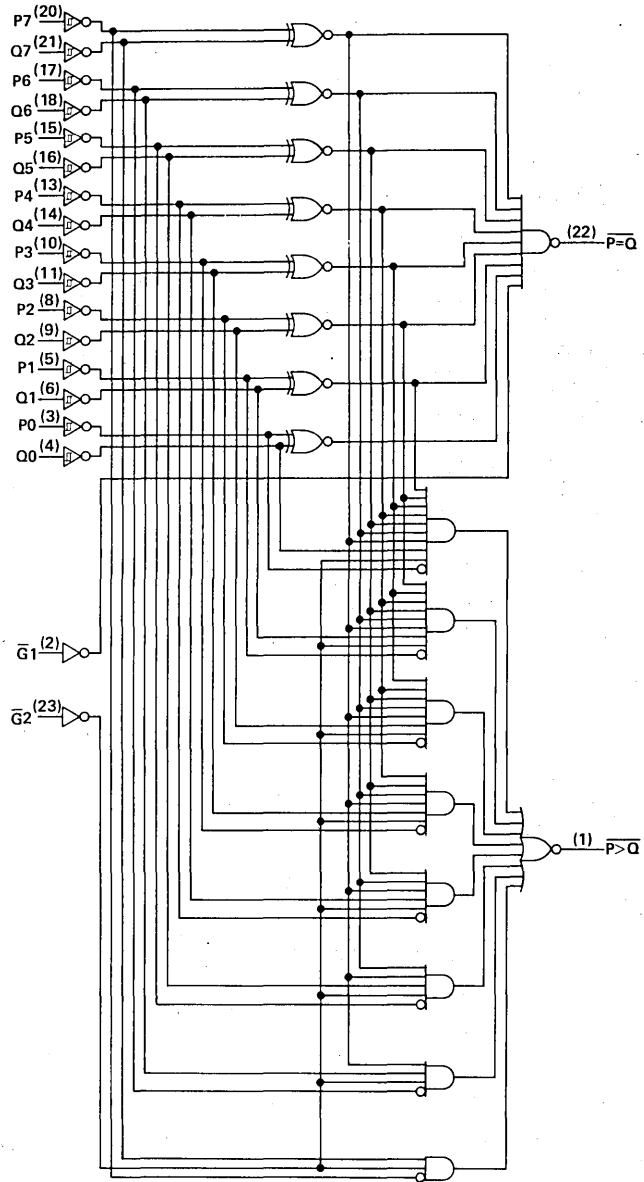

Pin numbers shown on logic notation are for DW, JT, or NT packages.

**TYPES SN54LS688, SN54LS689,
SN74LS688, SN74LS689
8-BIT IDENTITY COMPARATORS**

'LS688, 'LS689 logic diagram (positive logic)

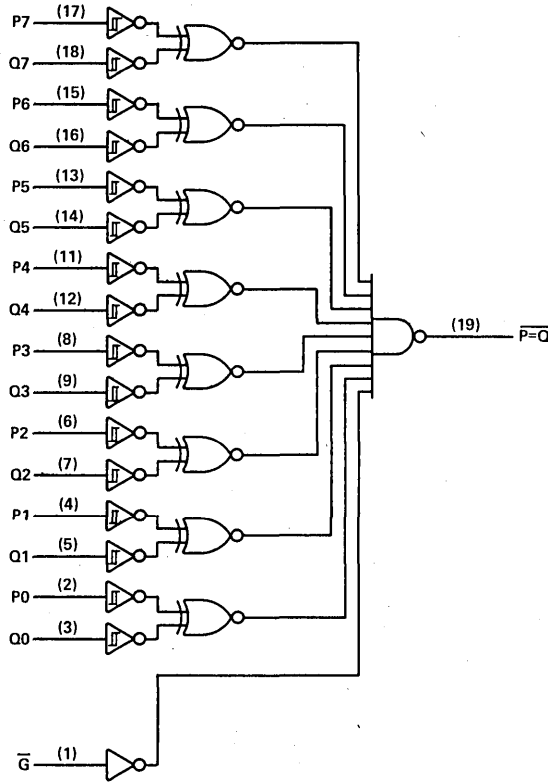

Pin numbers shown on logic notation are for DW, J or N packages.

absolute maximum ratings over operating free-air temperature range (unless otherwise noted)

Supply voltage (see Note 1)	7 V
Input voltage: Q inputs of 'LS682 and 'LS683	5.5 V
All other inputs	7 V
Off-state output voltage: 'LS683, 'LS685, 'LS687, 'LS689	7 V
Operating free-air temperature range: SN54LS682 thru SN54LS689	-55°C to 125°C
SN74LS682 thru SN74LS689	0°C to 70°C
Storage temperature range	-65°C to 150°C

NOTE 1: Voltage values are with respect to network ground terminal.

3 TTL DEVICES

TYPES SN54LS682, SN54LS684, SN54LS686, SN54LS688, SN74LS682, SN74LS684, SN74LS686, SN74LS688

8-BIT MAGNITUDE/IDENTITY COMPARATORS WITH TOTEM-POLE OUTPUTS

'LS682, 'LS684, 'LS686, 'LS688

recommended operating conditions

	SN54LS'			SN74LS'			UNIT
	MIN	NOM	MAX	MIN	NOM	MAX	
Supply voltage, V_{CC}	4.5	5	5.5	4.75	5	5.25	V
High-level output current, I_{OH}	-400			-400			μ A
Low-level output current, I_{OL}	12			24			mA
Operating free-air temperature, T_A	-55		125	0		70	$^{\circ}$ C

electrical characteristics over recommended operating free-air temperature range (unless otherwise noted)

PARAMETER		TEST CONDITIONS†	SN54LS'			SN74LS'			UNIT	
			MIN	TYP‡	MAX	MIN	TYP‡	MAX		
V_{IH}	High-level input voltage		2			2			V	
V_{IL}	Low-level input voltage		0.7			0.8			V	
$V_{T+} - V_{T-}$	Hysteresis	P or Q inputs	0.4			0.4			V	
V_{IK}	Input clamp voltage	$V_{CC} = \text{MIN}$, $I_I = -18 \text{ mA}$	-1.5			-1.5			V	
V_{OH}	High-level output voltage	$V_{CC} = \text{MIN}$, $V_{IH} = 2 \text{ V}$, $V_{IL} = V_{IL\text{max}}$, $I_{OH} = -400 \mu\text{A}$	2.5			2.7			V	
V_{OL}	Low-level output voltage	$V_{CC} = \text{MIN}$, $V_{IH} = 2 \text{ V}$, $V_{IL} = V_{IL\text{max}}$	$I_{OL} = 12 \text{ mA}$ 0.25 0.4		$I_{OL} = 24 \text{ mA}$ 0.25 0.4		0.35 0.5		V	
I_I	Input current at maximum input voltage	Q inputs, 'LS682 All other inputs	$V_{CC} = \text{MAX}$, $V_I = 5.5 \text{ V}$			$V_{CC} = \text{MAX}$, $V_I = 7 \text{ V}$			0.1 0.1	mA
I_{IH}	High-level input current		$V_{CC} = \text{MAX}$, $V_I = 2.7 \text{ V}$			20 20			μ A	
I_{IL}	Low-level input current	Q inputs, 'LS682 All other inputs	$V_{CC} = \text{MAX}$, $V_I = 0.4 \text{ V}$			-0.4 -0.2			-0.4 -0.2	mA
I_{OS}^{\S}	Short-circuit output current	$V_{CC} = \text{MAX}$, $V_O = 0$	-20 -100		-20 -100				mA	
I_{CC}	Supply current								mA	
		'LS682	42 70		42 70					
		'LS684	40 65		40 65					
		'LS686	44 75		44 75					
		'LS688	40 65		40 65					

‡ All typical values are at $V_{CC} = 5 \text{ V}$, $T_A = 25^{\circ}\text{C}$.

§ Not more than one output should be shorted at a time, and duration of the short-circuit should not exceed one second.

NOTE 2: I_{CC} is measured with any \bar{Q} inputs grounded, all other inputs at 4.5 V, and all outputs open.

switching characteristics, $V_{CC} = 5 \text{ V}$, $T_A = 25^{\circ}\text{C}$

PARAMETER#	FROM (INPUTS)	TO (OUTPUT)	TEST CONDITIONS	'LS682		'LS684		'LS686		'LS688		UNIT
				MIN	TYP	MIN	TYP	MIN	TYP	MIN	TYP	
t_{PLH}	P	$\bar{P} = \bar{Q}$	$R_L = 667 \Omega$, $C_L = 45 \text{ pF}$, All other inputs low, See Note 3	13	25	15	25	13	25	18	27	ns
t_{PHL}				15	25	17	25	20	30	20	30	
t_{PLH}	Q	$\bar{P} = \bar{Q}$		14	25	16	25	13	25	18	27	ns
t_{PHL}				15	25	15	25	21	30	20	30	
t_{PLH}	\bar{G}, \bar{G}_1	$\bar{P} = \bar{Q}$						11	20	12	18	ns
t_{PHL}								19	30	13	20	
t_{PLH}	P	$\bar{P} > \bar{Q}$		20	30	22	30	19	30			ns
t_{PHL}				15	30	17	30	15	30			
t_{PLH}	Q	$\bar{P} > \bar{Q}$		21	30	24	30	18	30			ns
t_{PHL}				19	30	20	30	19	30			
t_{PLH}	\bar{G}_2	$\bar{P} > \bar{Q}$						21	30			ns
t_{PHL}								16	25			

$t_{PLH} \equiv$ propagation delay time, low-to-high-level outputs; $t_{PHL} \equiv$ propagation delay time, high-to-low-level output.

NOTE 3: See General Information Section for load circuits and voltage waveforms.

TYPES SN54LS683, SN54LS685, SN54LS687, SN54LS689, SN74LS683, SN74LS685, SN74LS687, SN74LS689 8-BIT MAGNITUDE/IDENTITY COMPARATORS WITH OPEN-COLLECTOR OUTPUTS

recommended operating conditions 'LS683, 'LS685, 'LS687, 'LS689

	SN54LS'			SN74LS'			UNIT
	MIN	NOM	MAX	MIN	NOM	MAX	
Supply voltage, V_{CC}	4.5	5	5.5	4.75	5	5.25	V
High-level output voltage, V_{OH}	5.5			5.5			V
Low-level output current, I_{OL}	12			24			mA
Operating free-air temperature, T_A	-55		125	0		70	°C

electrical characteristics over recommended operating free-air temperature range (unless otherwise noted)

PARAMETER		TEST CONDITIONS†	SN54LS'			SN74LS'			UNIT
			MIN	TYP‡	MAX	MIN	TYP‡	MAX	
V_{IH}	High-level input voltage		2			2			V
V_{IL}	Low-level input voltage		0.7			0.8			V
$V_{T+} - V_{T-}$	Hysteresis	P or Q inputs	0.4			0.4			V
V_{IK}	Input clamp voltage	$V_{CC} = \text{MIN}$, $I_I = -18 \text{ mA}$	-1.5			-1.5			V
I_{OH}	High-level output voltage	$V_{CC} = \text{MIN}$, $V_{IH} = 2 \text{ V}$, $V_{IL} = V_{IL\text{max}}$, $V_{OH} = 5.5 \text{ V}$	250			100			μA
V_{OL}	Low-level output voltage	$V_{CC} = \text{MIN}$, $V_{IH} = 2 \text{ V}$, $V_{IL} = V_{IL\text{max}}$	$I_{OL} = 12 \text{ mA}$	0.25	0.4	0.25	0.4	V	
			$I_{OL} = 24 \text{ mA}$			0.35	0.5		
I_I	Input current at maximum input voltage	Q inputs, 'LS683	$V_{CC} = \text{MAX}$, $V_I = 5.5 \text{ V}$		0.1		0.1	mA	
		All other inputs	$V_{CC} = \text{MAX}$, $V_I = 7 \text{ V}$						
I_{IH}	High-level input current	$V_{CC} = \text{MAX}$, $V_I = 2.7 \text{ V}$	20			20			μA
I_{IL}	Low-level input current	Q inputs, 'LS683	$V_{CC} = \text{MAX}$, $V_I = 0.4 \text{ V}$		-0.4		-0.4		mA
		All other inputs	$V_{CC} = \text{MAX}$, $V_I = 0.4 \text{ V}$		-0.2		-0.2		
I_{CC}	Supply current	'LS683	$V_{CC} = \text{MAX}$, See Note 2		42	70	42	70	mA
		'LS685			40	65	40	65	
		'LS687			44	75	44	75	
		'LS689			40	65	40	65	

† For conditions shown as MIN or MAX, use the appropriate value specified under recommended operating conditions.

‡ All typical values are at $V_{CC} = 5 \text{ V}$, $T_A = 25^\circ\text{C}$.

NOTE 2: I_{CC} is measured with any \bar{G} inputs grounded, all other inputs at 4.5 V, and all outputs open.

switching characteristics, $V_{CC} = 5 \text{ V}$, $T_A = 25^\circ\text{C}$

PARAMETER¶	FROM (INPUTS)	TO (OUTPUT)	TEST CONDITIONS	'LS683		'LS685		'LS687		'LS689		UNIT
				MIN	TYP	MAX	MIN	TYP	MAX	MIN	TYP	
t_{PLH}	P	$\bar{P} = \bar{Q}$	$R_L = 667 \Omega$, $C_L = 45 \text{ pF}$, All other inputs low, See Note 3	30	45	30	45	24	35	24	40	ns
t_{PHL}				20	30	19	35	20	30	22	35	
t_{PLH}	Q	$\bar{P} = \bar{Q}$		24	35	24	45	24	35	24	40	ns
t_{PHL}				23	35	23	35	20	30	22	35	
t_{PLH}	$\bar{G}, \bar{G}1$	$\bar{P} = \bar{Q}$						21	35	22	35	ns
t_{PHL}								18	30	19	30	
t_{PLH}	P	$\bar{P} > \bar{Q}$			31	45	32	45	24	35		ns
t_{PHL}					17	30	16	35	16	30		
t_{PLH}	Q	$\bar{P} > \bar{Q}$			30	45	30	45	24	35		ns
t_{PHL}					21	30	20	35	16	30		
t_{PLH}	$\bar{G}2$	$\bar{P} > \bar{Q}$						24	35		ns	
t_{PHL}								15	30			

¶ t_{PLH} = propagation delay time, low-to-high-level output; t_{PHL} = propagation delay time, high-to-low-level output.

NOTE 3: See General Information Section for load circuits and voltage waveforms.

3

TTL DEVICES

TYPES SN54LS690 THRU SN54LS693, SN74LS690 THRU SN74LS693 SYNCHRONOUS COUNTERS WITH OUTPUT REGISTERS AND MULTIPLEXED 3-STATE OUTPUTS

D2423, JANUARY 1981

- 4-Bit Counters/Registers
- Multiplexed Outputs for Counter or Latched Data
- 3-State Outputs Drive Bus Lines Directly
- 'LS690 . . . Decade Counter, Direct Clear
'LS691 . . . Binary Counter, Direct Clear
'LS692 . . . Decade Counter, Synchronous Clear
'LS693 . . . Binary Counter, Synchronous Clear

description

These low-power Schottky LSI devices incorporate synchronous counters, four-bit D-type registers, and quadruple two-line to one-line multiplexers with three-state outputs in a single 20-pin package. The counters can be programmed from the data inputs and have enable P inputs and enable T inputs and a ripple-carry output for easy expansion. The register/counter select input, R/C, selects the counter when low or the register when high for the three-state outputs, Q_A, Q_B, Q_C, and Q_D. These outputs are rated at 12 and 24 milliamperes (54LS/74LS) for good bus-driving performance.

Individual clock and clear inputs are provided for both the counter and the register. Both clock inputs are positive-edge triggered: The clear line is active low and is asynchronous on the 'LS690 and 'LS691, synchronous on the 'LS692 and 'LS693. Loading of the counter is accomplished when LOAD is taken low and a positive-transition occurs on the counter clock CCK.

Expansion is easily accomplished by connecting RCO of the first stage to ENT of the second stage, etc. All ENP inputs can be tied common and used as a master enable or disable control.

schematics of inputs and outputs

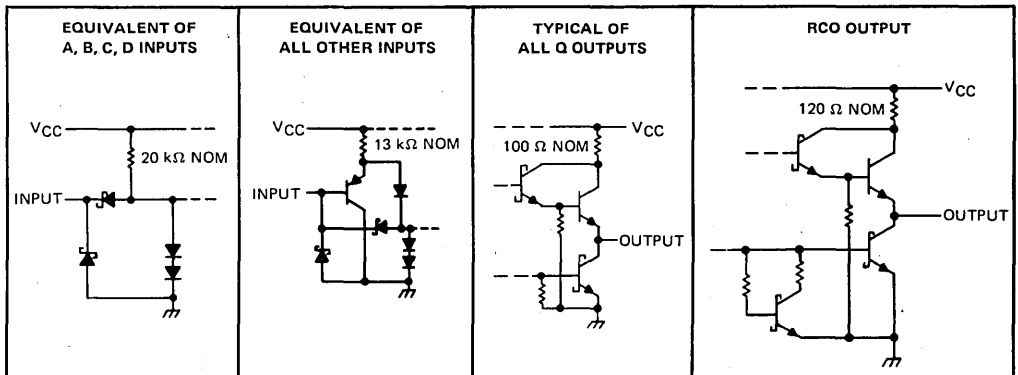

SN54LS690 THRU SN54LS693 . . . J PACKAGE
SN74LS690 THRU SN74LS693 . . . DW, J OR N PACKAGE

(TOP VIEW)

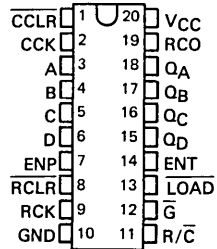

SN54LS690 THRU SN54LS693 . . . FK PACKAGE
SN74LS690 THRU SN74LS693 . . . FN PACKAGE

(TOP VIEW)

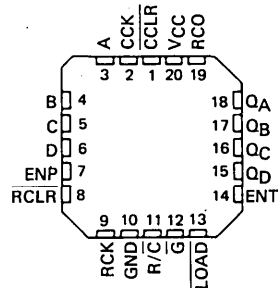

PRODUCTION DATA
This document contains information current as of publication date. Products conform to specifications per the terms of Texas Instruments standard warranty. Production processing does not necessarily include testing of all parameters.

TEXAS INSTRUMENTS
POST OFFICE BOX 225012 • DALLAS, TEXAS 75265

3-1303

TYPE SN54LS690, SN74LS690
SYNCHRONOUS COUNTERS WITH OUTPUT REGISTERS
AND MULTIPLEXED 3-STATE OUTPUTS

logic diagrams

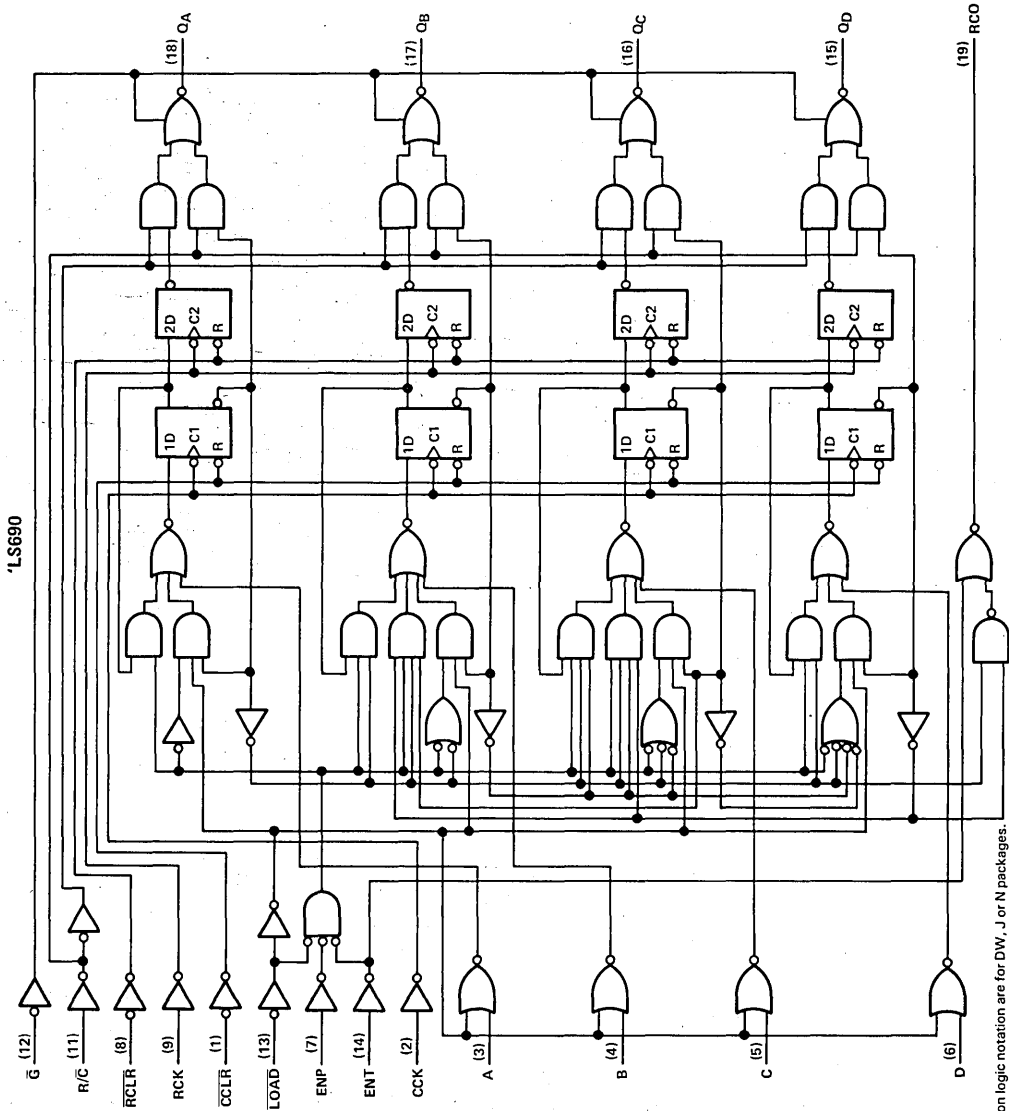

Pin numbers shown on logic notation are for DW, J or N packages.

TYPE SN54LS691, SN74LS691
 SYNCHRONOUS COUNTERS WITH OUTPUT REGISTERS
 AND MULTIPLEXED 3-STATE OUTPUTS

logic diagrams (continued)

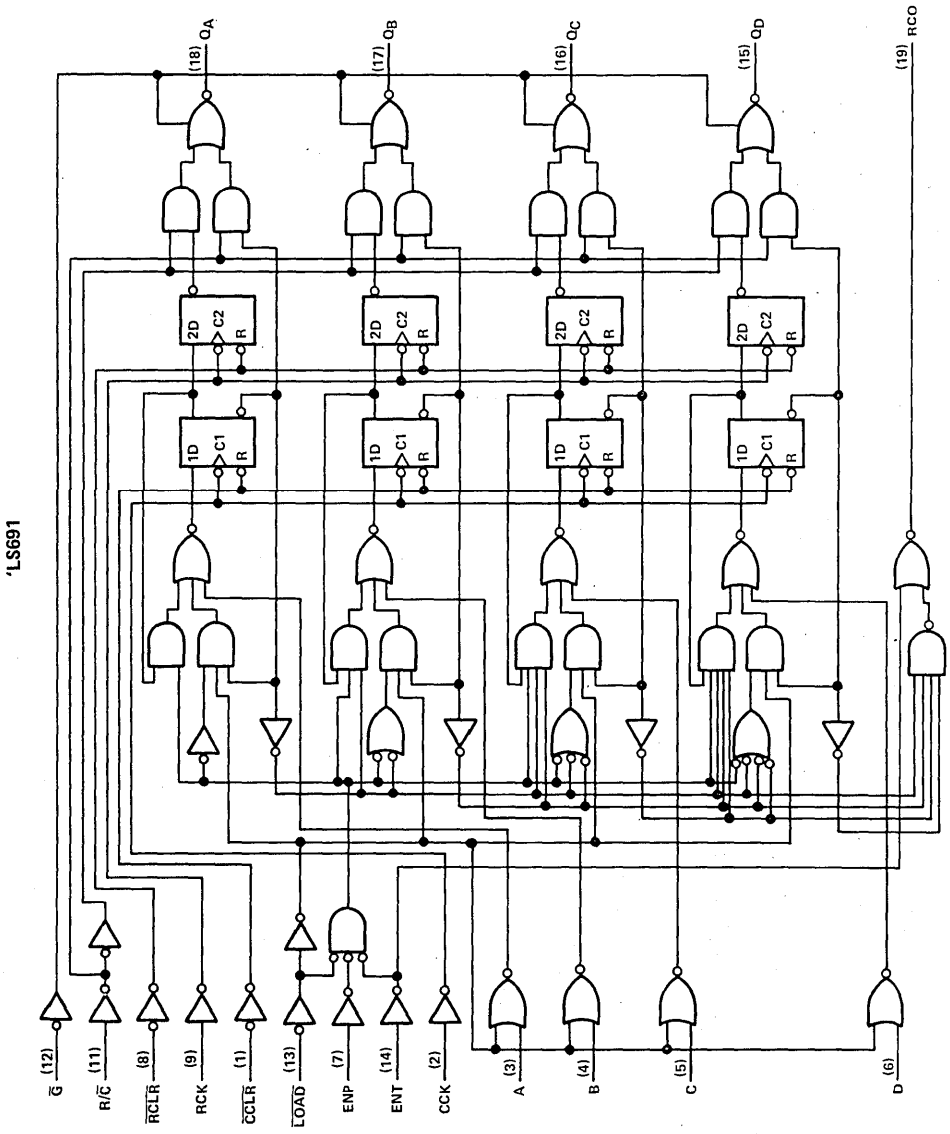

'LS691

Pin numbers shown on logic notation are for DW, J, or N packages.

TYPE SN54LS692, SN74LS692
SYNCHRONOUS COUNTERS WITH OUTPUT REGISTERS
AND MULTIPLEXED 3-STATE OUTPUTS

logic diagrams (continued)

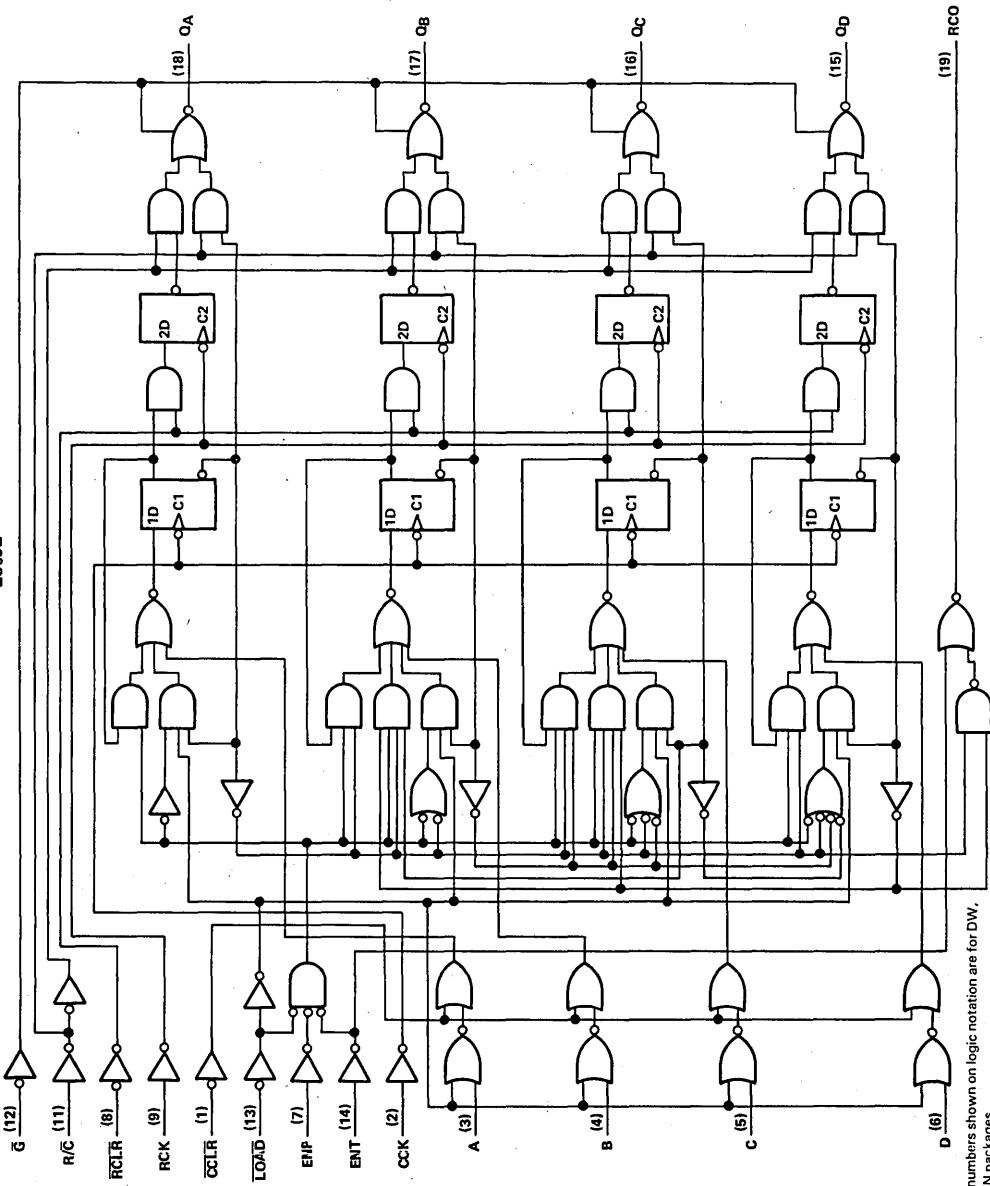

Pin numbers shown on logic notation are for DW, J or N packages.

3 TTL DEVICES

'LS692

TYPE SN54LS693, SN74LS693
 SYNCHRONOUS COUNTERS WITH OUTPUT REGISTERS
 AND MULTIPLEXED 3-STATE OUTPUTS

logic diagrams (continued)

'LS693

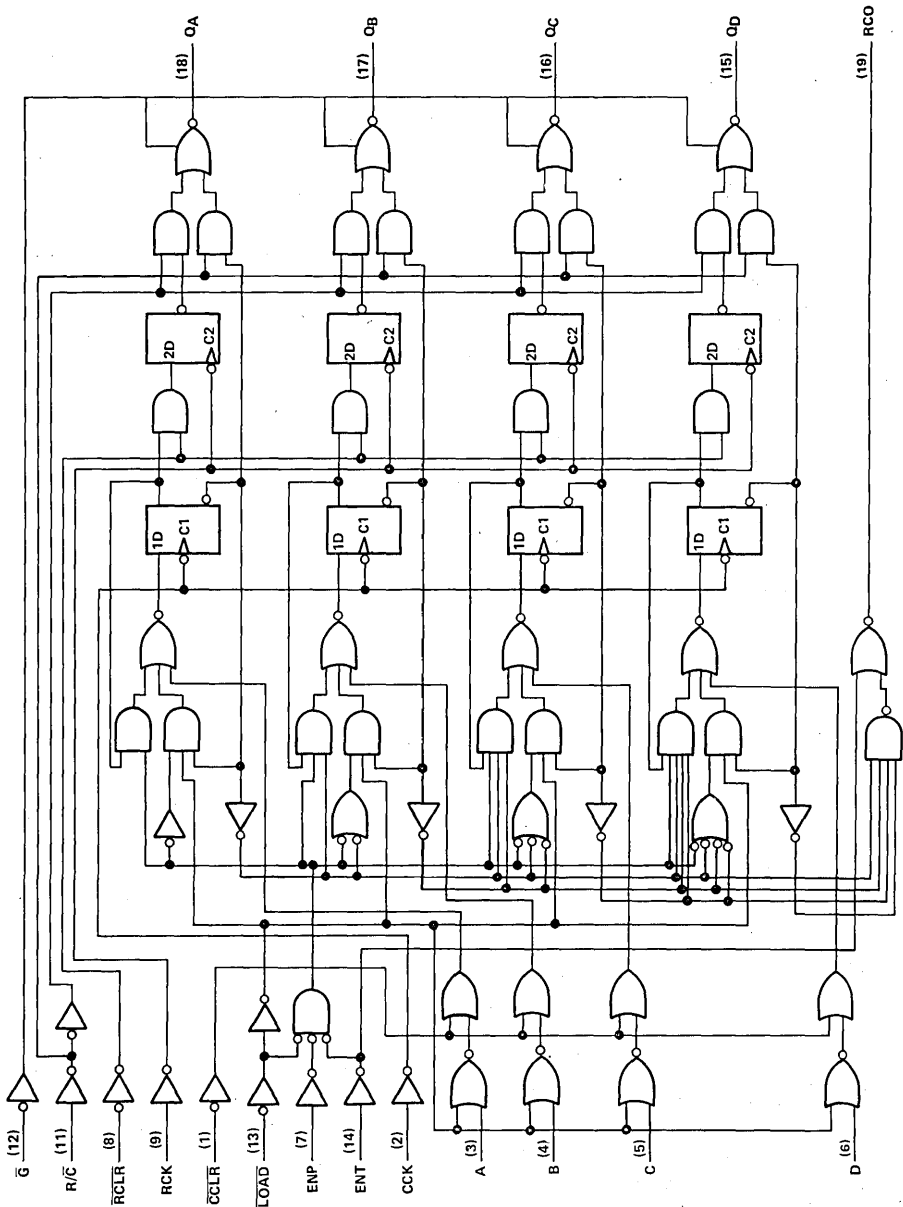

Pin numbers shown on logic notation are for DW, J or N packages.

3

TTL DEVICES

TYPES SN54LS690 THRU SN54LS693, SN74LS690 THRU SN74LS693 SYNCHRONOUS COUNTERS WITH OUTPUT REGISTERS AND MULTIPLEXED 3-STATE OUTPUTS

logic symbols

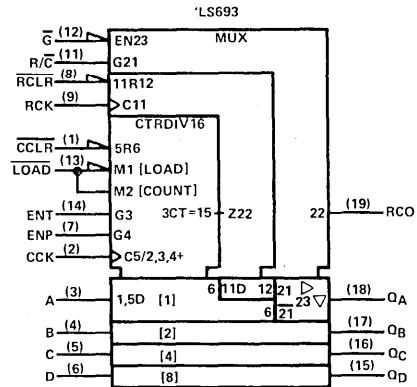
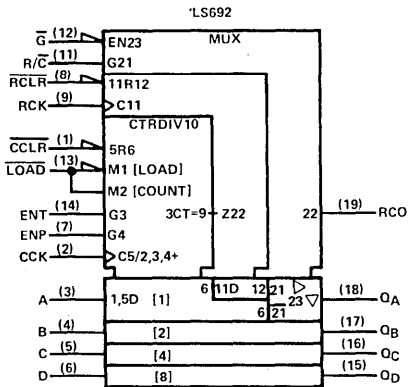
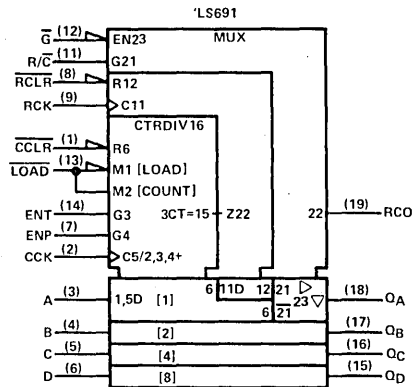
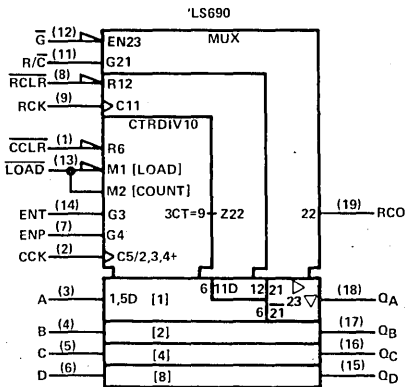

Pin numbers shown on logic notation are for DW, J or N packages.

TYPES SN54LS690 THRU SN54LS693, SN74LS690 THRU SN74LS693 SYNCHRONOUS COUNTERS WITH OUTPUT REGISTERS AND MULTIPLEXED 3-STATE OUTPUTS

absolute maximum ratings over operating free-air temperature range (unless otherwise noted)

Supply voltage, V_{CC} (see Note 1)	7 V
Input voltage	7 V
Off-state output voltage	5.5 V
Operating free-air temperature range: SN54LS690 thru SN54LS693	-55°C to 125°C
SN74LS690 thru SN74LS693	0°C to 70°C
Storage temperature range	-65°C to 150°C

NOTE 1: Voltage values are with respect to network ground terminal.

recommended operating conditions

		SN54LS'			SN74LS'			UNIT		
		MIN	NOM	MAX	MIN	NOM	MAX			
V_{CC}	Supply voltage	4.5	5	5.5	4.75	5	5.25	V		
V_{IH}	High-level input voltage	2			2			V		
V_{IL}	Low-level input voltage				0.7			V		
I_{OH}	High-level output current	Q				-1			mA	
		RCO				-0.4			mA	
I_{OL}	Low-level output current	Q				12			mA	
		RCO				4			mA	
f_{clock}	Clock frequency	CCK	0		20		0		20	MHz
		RCK	0		20		0		20	MHz
t_w	Pulse duration	'LS690, 'LS691	CCK high or low		25		25		ns	
			RCK high or low		25		25			
			RCLR low		20		20			
			CCLR low		20		20			
t_{su}	Setup time before CCK \uparrow	'LS690, 'LS691	A thru D		30		30		ns	
			ENP or ENT		30		30			
			LOAD \downarrow		30		30			
			CCLR \downarrow		40		40			
			CCLR \uparrow inactive		25		25			
t_{su}	Setup time before RCK \uparrow	'LS690, 'LS691	CCK \uparrow (see Note 2)		30		30		ns	
			RCLR \uparrow inactive		25		25			
			RCLR \downarrow		20		20			
t_h	Hold time	Any input from CCK \uparrow or RCK \uparrow		0		0		ns		
T_A	Operating free-air temperature	-55		125		0		70	°C	

NOTE 2: This set up time ensures the register will see stable data from the counter outputs. The clocks may be tied together in which case the register state will be one clock pulse behind the counter.

3
TTL DEVICES

TYPES SN54LS690 THRU SN54LS693, SN74LS690 THRU SN74LS693 SYNCHRONOUS COUNTERS WITH OUTPUT REGISTERS AND MULTIPLEXED 3-STATE OUTPUTS

electrical characteristics over recommended operating free-air temperature range (unless otherwise noted)

PARAMETER	TEST CONDITIONS†	SN54LS'		SN74LS'		UNIT		
		MIN	TYP‡	MAX	MIN		TYP‡	MAX
V_{IK}	$V_{CC} = \text{MIN}, I_I = -18 \text{ mA}$			-1.5		-1.5	V	
V_{OH}	Any Q	$V_{CC} = \text{MIN}, V_{IH} = 2 \text{ V},$ $V_{IL} = \text{MAX}$	$I_{OH} = -1 \text{ mA}$	2.4	3.1		V	
	Any Q		$I_{OH} = -2.6 \text{ mA}$			2.4		3.1
	RCO		$I_{OH} = -0.4 \text{ mA}$	2.5	3.2	2.7		3.2
V_{OL}	Any Q	$V_{CC} = \text{MIN}, V_{IH} = 2 \text{ V},$ $V_{IL} = \text{MAX}$	$I_{OL} = 12 \text{ mA}$	0.25	0.4	0.25	0.4	V
	Any Q		$I_{OL} = 24 \text{ mA}$			0.35	0.5	
	RCO		$I_{OL} = 4 \text{ mA}$	0.25	0.4	0.25	0.4	
	RCO		$I_{OL} = 8 \text{ mA}$			0.35	0.5	
I_{OZH}	Any Q	$V_{CC} = \text{MAX}, V_{IH} = 2 \text{ V}, V_{IL} = \text{MAX},$ $V_O = 2.7 \text{ V}$			20	20	μA	
I_{OZL}	Any Q	$V_{CC} = \text{MAX}, V_{IH} = 2 \text{ V}, V_{IL} = \text{MAX},$ $V_O = 0.4 \text{ V}$			-20	-20	μA	
I_I		$V_{CC} = \text{MAX}, V_I = 7 \text{ V}$		0.1		0.1	mA	
I_{IH}		$V_{CC} = \text{MAX}, V_I = 2.7 \text{ V}$		20		20	μA	
I_{iL}	A thru D	$V_{CC} = \text{MAX}, V_I = 0.4 \text{ V}$		-0.4		-0.4	mA	
	All others			-0.2		-0.2		
$I_{OS}§$	Any Q	$V_{CC} = \text{MAX}, V_O = 0 \text{ V}$		-30	-130	-30	-130	mA
	RCO			-20	-100	-20	-100	
I_{CCH}	All outputs open	$V_{CC} = \text{MAX},$	See Note 3	46	65	46	65	mA
I_{CCL}			See Note 4	48	70	48	70	
I_{CCZ}			See Note 5	48	70	48	70	

† For conditions shown as MIN or MAX, use the appropriate value specified under recommended operating conditions.

‡ All typical values are at $V_{CC} = 5 \text{ V}, T_A = 25^\circ\text{C}$.

§ Not more than one output should be shorted at a time and duration of short-circuit should not exceed one second.

NOTES: 3. I_{CCH} is measured after two 4.5 V to 0-V to 4.5-V pulses have been applied to CCK and RCK while \bar{G} is grounded and all other inputs are at 4.5 V.

4. I_{CCL} is measured after two 0-V to 4.5-V to 0-V pulses have been applied to CCK and RCK while all other inputs are grounded.

5. I_{CCZ} is measured after two 0-V to 4.5-V to 0-V pulses have been applied to CCK and RCK while \bar{G} is at 4.5 V and all other inputs are grounded.

3

TTL DEVICES

**TYPES SN54LS690 THRU SN54LS693, SN74LS690 THRU SN74LS693
SYNCHRONOUS COUNTERS WITH OUTPUT REGISTERS
AND MULTIPLEXED 3-STATE OUTPUTS**

switching characteristics, $V_{CC} = 5\text{ V}$, $T_A = 25^\circ\text{C}$ (see note 6)

PARAMETER	FROM (INPUT)	TO (OUTPUT)	TEST CONDITIONS	'LS690, 'LS691			'LS692, 'LS693			UNIT
				MIN	TYP	MAX	MIN	TYP	MAX	
t_{PLH}	CCK \uparrow	RCO	$R_L = 2\text{ k}\Omega$, $C_L = 15\text{ pF}$	23	40		23	40	ns	
t_{PHL}				23	40	23	40			
t_{PLH}	ENT	RCO		13	20		13	20	ns	
t_{PHL}				13	20	13	20			
t_{PLH}	CCK \uparrow	Q		12	20		12	20	ns	
t_{PHL}				17	25	17	25			
t_{PLH}	RCK \uparrow	Q	12	20		12	20	ns		
t_{PHL}			17	25	17	25				
t_{PHL}	$\overline{\text{CCLR}}\downarrow$	Q	23	40				ns		
t_{PHL}	$\overline{\text{RCLR}}\downarrow$	Q	20	30				ns		
t_{PLH}	R/ $\overline{\text{C}}$	Q	$R_L = 667\ \Omega$, $C_L = 45\text{ pF}$	16	25		16	25	ns	
t_{PHL}				16	25	16	25			
t_{PZH}	$\overline{\text{G}}\downarrow$	Q		19	30		19	30	ns	
t_{PZL}				19	30	19	30			
t_{PHZ}	$\overline{\text{G}}\uparrow$	Q		17	30		17	30	ns	
t_{PLZ}				17	30	17	30			

NOTE 6: See General Information Section for load circuits and voltage waveforms.

- t_{PLH} \equiv Propagation delay time, low-to-high-level output
- t_{PHL} \equiv Propagation delay time, high-to-low-level output
- t_{PZH} \equiv Output enable time to high level
- t_{PZL} \equiv Output enable time to low level
- t_{PHZ} \equiv Output disable time from high level
- t_{PLZ} \equiv Output disable time from low level

TYPES SN54LS690, SN54LS692, SN74LS690, SN74LS692
 SYNCHRONOUS COUNTERS WITH OUTPUT REGISTERS
 AND MULTIPLEXED 3-STATE OUTPUTS

typical operating sequences

3

TTL DEVICES

'LS690 DECADE COUNTER, Asynchronous Clear
 'LS692 DECADE COUNTER, Synchronous Clear

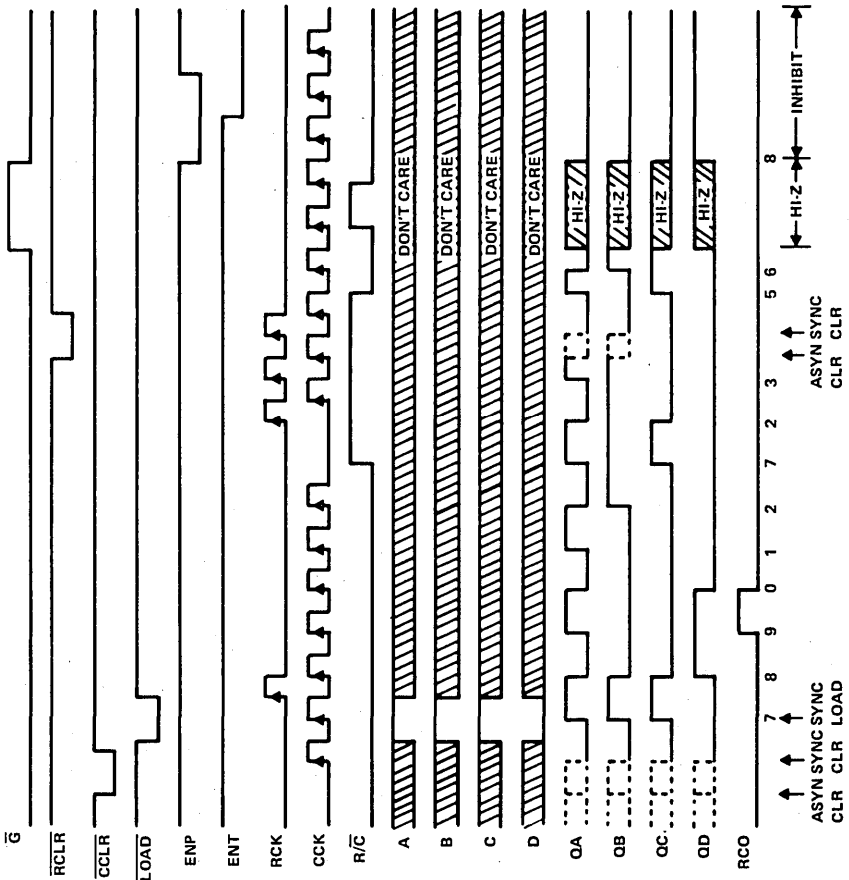

TYPES SN54LS691, SN54LS693, SN74LS691, SN74LS693
 SYNCHRONOUS COUNTERS WITH OUTPUT REGISTERS
 AND MULTIPLEXED 3-STATE OUTPUTS

typical operating sequences (continued)

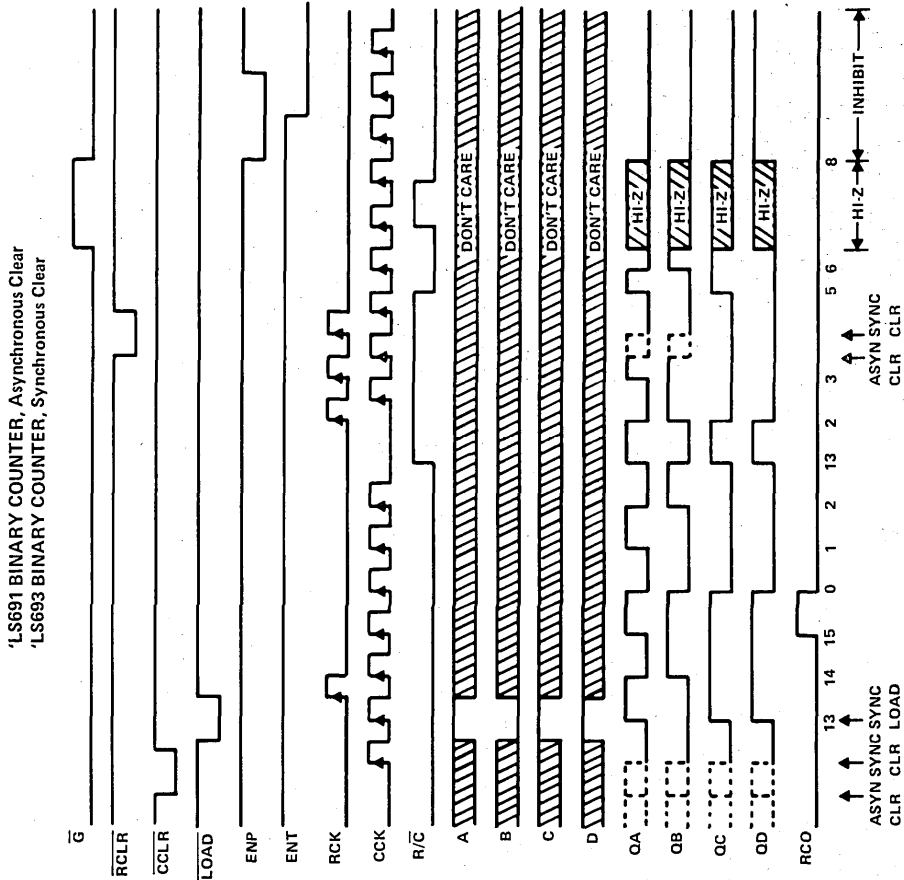

TTL DEVICES

TYPES SN54LS696 THRU SN54LS699, SN74LS696 THRU SN74LS699 SYNCHRONOUS UP/DOWN COUNTERS WITH OUTPUT REGISTERS AND MULTIPLEXED 3-STATE OUTPUTS

D2424, JANUARY 1981

- 4-Bit Counters/Registers
- Multiplexed Outputs for Counter or Latched Data
- 3-State Outputs Drive Bus Lines Directly
- 'LS696 . . . Decade Counter, Direct Clear
- 'LS697 . . . Binary Counter, Direct Clear
- 'LS698 . . . Decade Counter, Synchronous Clear
- 'LS699 . . . Binary Counter, Synchronous Clear

description

These low-power Schottky LSI devices incorporate synchronous up/down counters, four-bit D-type registers, and quadruple two-line to one-line multiplexers with three state outputs in a single 20-pin package. The up/down counters are programmable from the data inputs and feature enable \bar{P} and enable \bar{T} and a ripple-carry output for easy expansion. The register/counter select input R/\bar{C} , selects the counter when low and the register when high for the three-state outputs, Q_A , Q_B , Q_C , and Q_D . These outputs are rated at 12 and 24 milliamperes (54LS/74LS) for good bus driving performance.

Both the counter clock CCK and register clock RCK are positive-edge triggered. The counter clear CCLR is active low and is a synchronous on the 'LS696 and 'LS697, synchronous on the 'LS698 and 'LS699. Loading of the counter is accomplished when \overline{LOAD} is taken low and a positive transition occurs on the counter clock CCK.

Expansion is easily accomplished by connecting \overline{RCO} of the first stage to \overline{ENT} of the second stage, etc. All \overline{ENP} inputs can be tied common and used as a master enable or disable control.

schematics of inputs and outputs

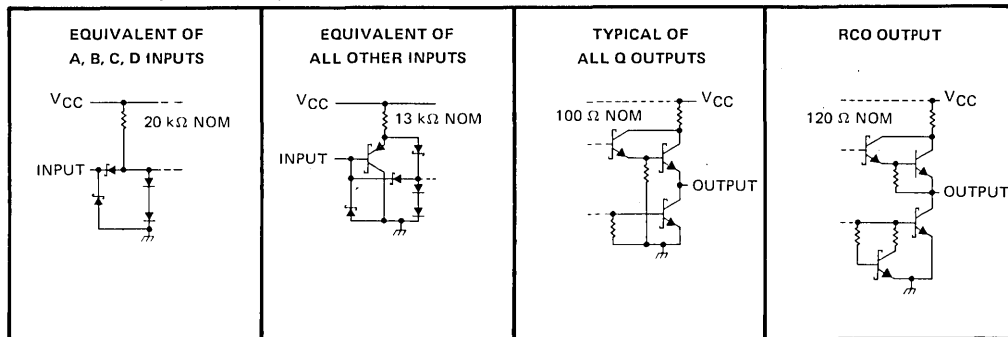

SN54LS696 THRU SN54LS699 . . . J PACKAGE
SN74LS696 THRU SN74LS699 . . . DW, J OR N PACKAGE

(TOP VIEW)

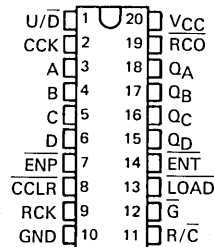

SN54LS696 THRU SN54LS699 . . . FK PACKAGE
SN74LS696 THRU SN74LS699 . . . FN PACKAGE

(TOP VIEW)

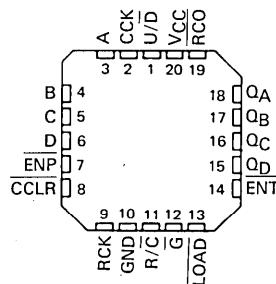

PRODUCTION DATA
This document contains information current as of publication date. Products conform to specifications per the terms of Texas Instruments standard warranty. Production processing does not necessarily include testing of all parameters.

TEXAS INSTRUMENTS
POST OFFICE BOX 226012 • DALLAS, TEXAS 75265

3-1315



TTL DEVICES

TYPES SN54LS696 THRU SN54LS699, SN74LS696 THRU SN74LS699
SYNCHRONOUS UP/DOWN COUNTERS
WITH OUTPUT REGISTERS AND MULTIPLEXED 3-STATE OUTPUTS

logic symbols

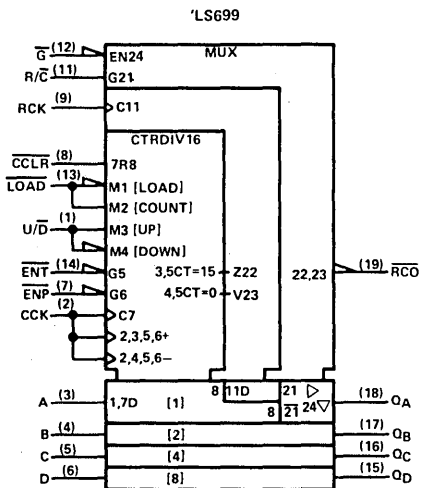
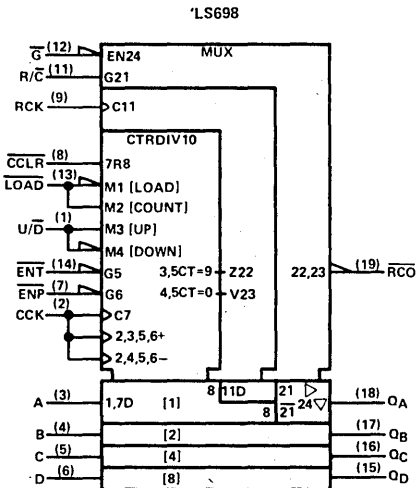
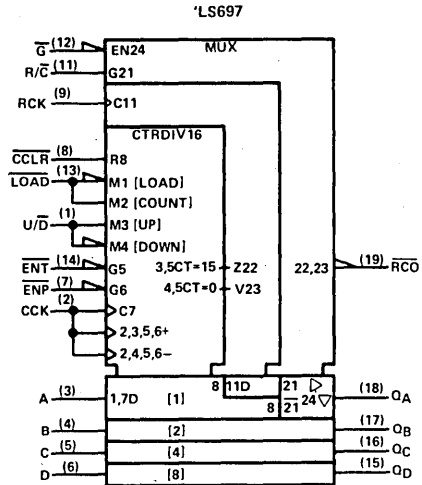
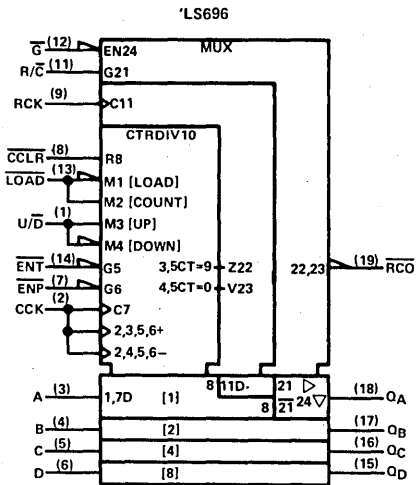

Pin numbers shown on logic notation are for DW, J or N packages.

3 TTL DEVICES

TYPES SN54LS696, SN74LS696
SYNCHRONOUS UP/DOWN COUNTERS
WITH OUTPUT REGISTERS AND MULTIPLEXED 3-STATE OUTPUTS

logic diagrams

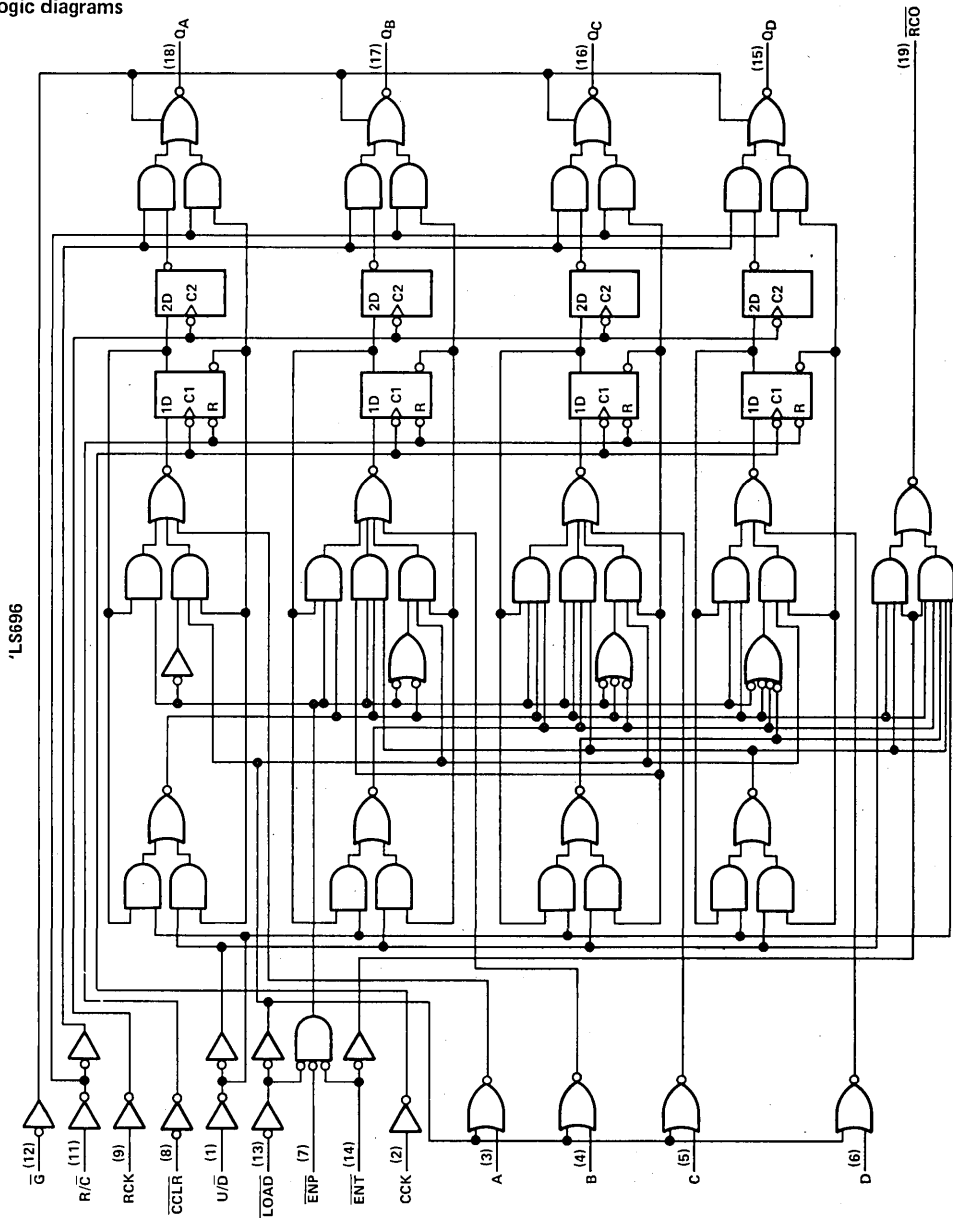

Pin numbers shown on logic notation are for DW, J or N packages.

TYPES SN54LS697, SN74LS697
SYNCHRONOUS UP/DOWN COUNTERS
WITH OUTPUT REGISTERS AND MULTIPLEXED 3-STATE OUTPUTS

logic diagrams (continued)

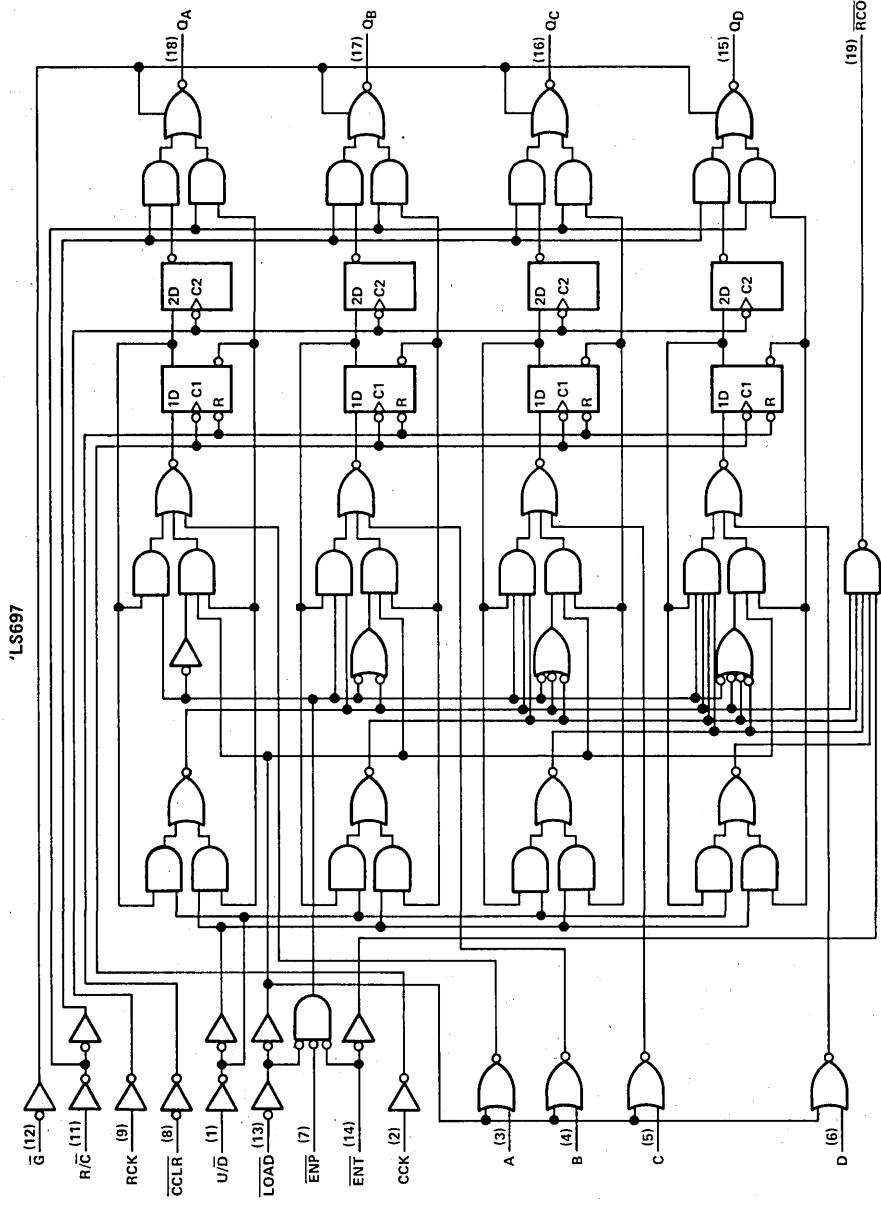

Pin numbers shown on logic notation are for DW, J or N packages.



TTL DEVICES

TYPES SN54LS696, SN74LS696, SN54LS698, SN74LS698
 SYNCHRONOUS UP/DOWN COUNTERS
 WITH OUTPUT REGISTERS AND MULTIPLEXED 3-STATE OUTPUTS

logic diagrams (continued)

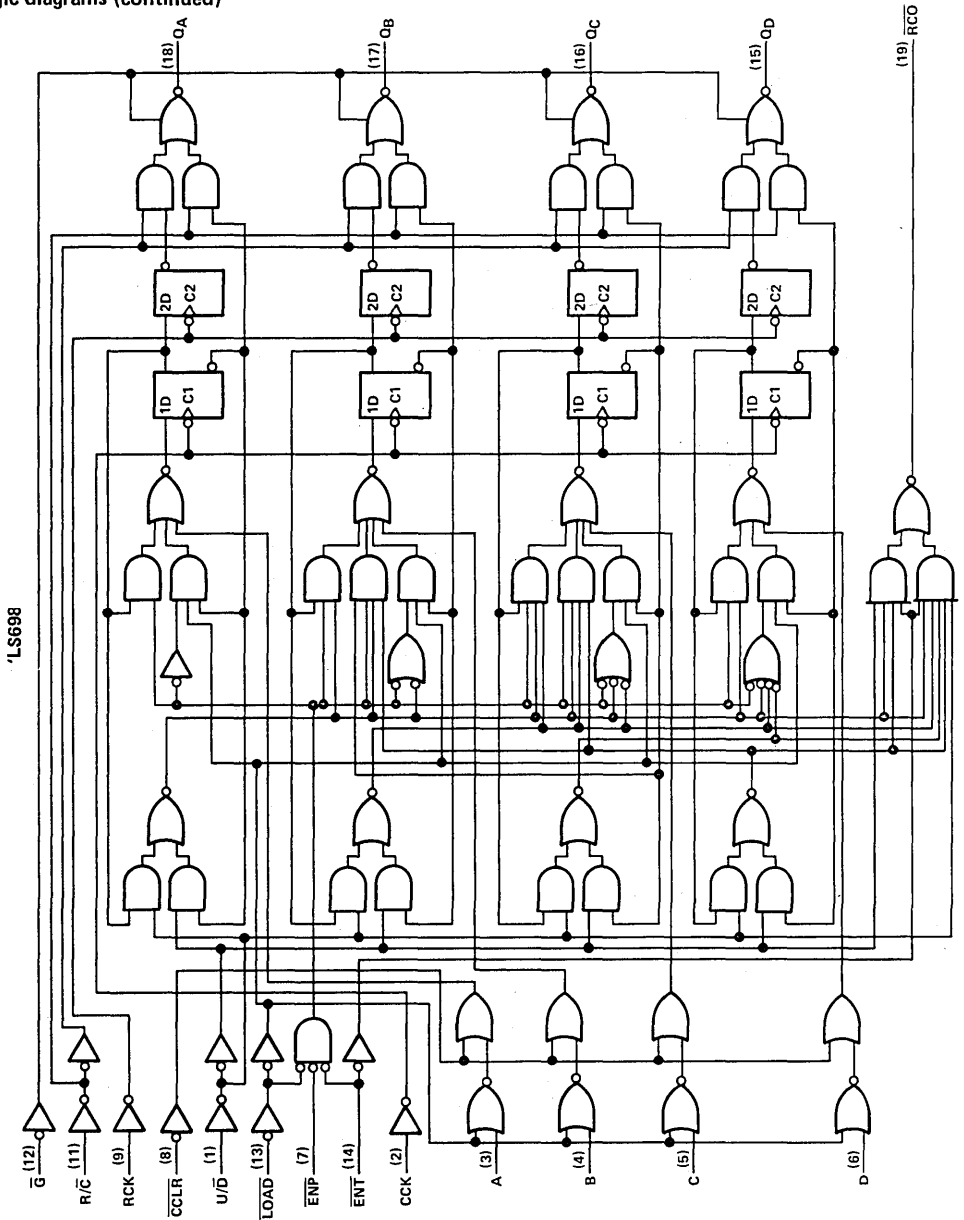

'LS698

Pin numbers shown on logic notation are for DW, J or N packages.

TTL DEVICES **3**

TYPES SN54LS697, SN74LS697, SN54LS699, SN74LS699
SYNCHRONOUS UP/DOWN COUNTERS
WITH OUTPUT REGISTERS AND MULTIPLEXED 3-STATE OUTPUTS

logic diagrams (continued)

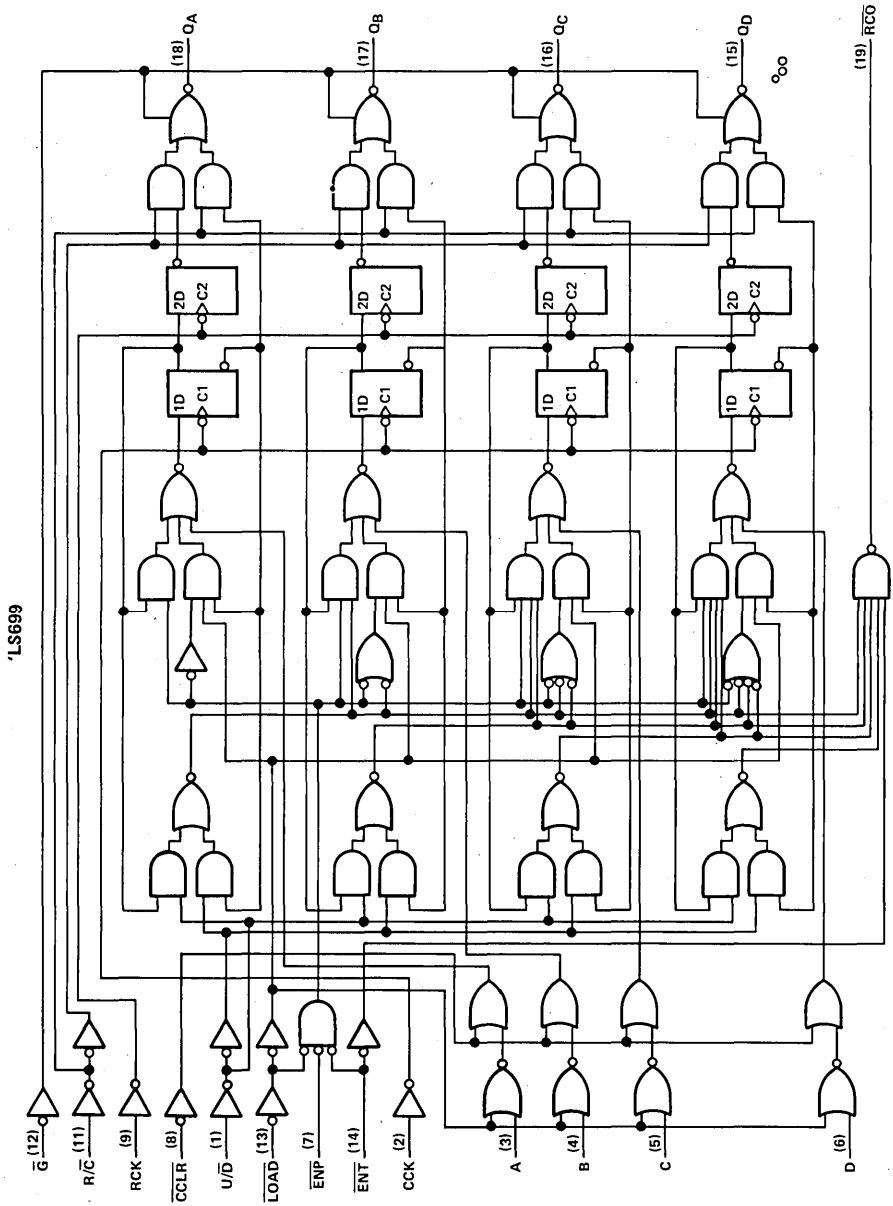

Pin numbers shown on logic notation are for DW, J or N packages.

3 TTL DEVICES

TYPES SN54LS696 THRU SN54LS699, SN74LS696 THRU SN74LS699 SYNCHRONOUS UP/DOWN COUNTERS WITH OUTPUT REGISTERS AND MULTIPLEXED 3-STATE OUTPUTS

absolute maximum ratings over operating free-air temperature range (unless otherwise noted)

Supply voltage, V_{CC} (see Note 1)	7 V
Input voltage	7 V
Off-state output voltage	5.5 V
Operating free-air temperature range: SN54LS696 thru SN54LS699	-55°C to 125°C
SN74LS696 thru SN74LS699	0°C to 70°C
Storage temperature range	-65°C to 150°C

NOTE 1: Voltage values are with respect to network ground terminal.

recommended operating conditions

		SN54LS'			SN74LS'			UNIT
		MIN	NOM	MAX	MIN	NOM	MAX	
V_{CC}	Supply voltage	4.5	5	5.5	4.75	5	5.25	V
I_{OH}	High-level output current	Q		-1			-2.6	mA
		\overline{RCO}		-0.4			-0.4	
I_{OL}	Low-level output current	Q		12			24	mA
		\overline{RCO}		4			8	
f_{clock}	Clock frequency	CCK	0	20	0	20	MHz	
		RCK	0	20	0	20		
t_w	Pulse duration	CCK high or low	25		25		ns	
		RCK high or low	25		25			
		'LS696, 'LS697 \overline{CCLR} low	20		20			
t_{su}	Setup time before CCK ↑	A thru D	30		30		ns	
		\overline{ENP} or \overline{ENT}	30		30			
		\overline{LOAD}	30		30			
		U/ \overline{D}	35		35			
		'LS696, 'LS697, \overline{CCLR} inactive	25		25			
		'LS698, 'LS699, \overline{CCLR}	30		30			
t_{su}	Setup time CCK ↑ before RCK ↑ (see Note 2)	30		30		ns		
t_h	Hold time	0		0		ns		
T_A	Operating free-air temperature	-65	125	0	70	°C		

NOTE 2: This set up time ensures the register will see stable data from the counter outputs. The clocks may be tied together in which case the register state will be one clock pulse behind the counter.



TTL DEVICES

TYPES SN54LS696 THRU SN54LS699, SN74LS696 THRU SN74LS699 SYNCHRONOUS UP/DOWN COUNTERS WITH OUTPUT REGISTERS AND MULTIPLEXED 3-STATE OUTPUTS

electrical characteristics over recommended operating free-air temperature range (unless otherwise noted)

PARAMETER	TEST CONDITIONS†	SN54LS*		SN74LS*		UNIT			
		MIN	TYP‡	MAX	MIN		TYP‡	MAX	
V _{IH} High-level input voltage		2		2		V			
V _{IL} Low-level input voltage			0.7			0.8 V			
V _{IK} Input clamp voltage	V _{CC} =MIN, I _I =-18 mA			-1.5		-1.5 V			
V _{OH} High-level output voltage	Any Q Any Q RCO	V _{CC} =MIN, V _{IH} =2 V, V _{IL} =V _{IL} max	I _{OH} =-1 mA	2.4	3.1		V		
			I _{OH} =-2.6 mA			2.4		3.1	
			I _{OH} =-400 μA	2.5	3.2	2.7		3.2	
V _{OL} Low-level output voltage	Any Q Any Q RCO RCO	V _{CC} =MIN, V _{IH} =2 V, V _{IL} =V _{IL} max	I _{OL} =12 mA		0.25	0.4	0.25	0.4	V
			I _{OL} =24 mA				0.35	0.5	
			I _{OL} =4 mA		0.25	0.4	0.25	0.4	
			I _{OL} =8 mA				0.35	0.5	
I _{OZH} Off-state output current, high-level voltage applied	Any Q	V _{CC} =MAX, \bar{G} at 2 V, V _O =2.7 V			20		20	μA	
I _{OZL} Off-state output current, low-level voltage applied	Any Q	V _{CC} =MAX, \bar{G} at 2 V, V _O =0.4 V			-20		-20	μA	
I _I Input current at maximum input voltage		V _{CC} =MAX, V _I =7 V			0.1		0.1	mA	
I _{IH} High-level input current		V _{CC} =MAX, V _I =2.7 V			20		20	μA	
I _{IL} Low-level input current	A thru D	V _{CC} =MAX, V _I =0.4 V			-0.4		-0.4	mA	
	All others				-0.2		-0.2		
I _{OS} Short-circuit output current §	Any Q	V _{CC} =MAX, V _O =0 V			-30	-130	-30	-130	mA
	RCO				-20	-100	-20	-100	
I _{CCH} Supply current, outputs high		V _{CC} =MAX, All outputs open	See Note 3	46	65	46	65	mA	
I _{CCL} Supply current, outputs low			See Note 4	48	70	48	70		
I _{CCZ} Supply current, outputs off			See Note 5	48	70	48	70		

† For conditions shown as MIN or MAX, use the appropriate value specified under recommended operating conditions.

‡ All typical values are at V_{CC} = 5 V, T_A = 25°C.

§ Only one output should be shorted at a time, and duration of the short-circuit should not exceed one second.

NOTES: 3. I_{CCH} is measured after two 4.5 V to 0 V to 4.5 V pulses have been applied to CCK and RCK while \bar{G} is grounded and all other inputs are at 4.5 V.

4. I_{CCL} is measured after two 0 V to 4.5 V to 0 V pulses have been applied to CCK and RCK while all other inputs are grounded.

5. I_{CCZ} is measured after two 0 V to 4.5 V to 0 V pulses have been applied to CCK and RCK while \bar{G} is at 4.5 V and all other inputs are grounded.

switching characteristics, V_{CC} = 5 V, T_A = 25°C (see note 6)

PARAMETER	FROM (INPUT)	TO (OUTPUT)	TEST CONDITIONS	'LS696, 'LS697			'LS698, 'LS699			UNIT
				MIN	TYP	MAX	MIN	TYP	MAX	
t _{PLH}	CCK↑	\overline{RCO}	R _L = 2 kΩ, C _L = 15 pF	23	40		23	40		ns
t _{PHL}				23	40		23	40		ns
t _{PLH}	\overline{ENT}	\overline{RCO}		13	20		13	20		ns
t _{PHL}				13	20		13	20		ns
t _{PLH}	CCK↑	Q		12	20		12	20		ns
t _{PHL}				17	25		17	25		ns
t _{PLH}	RCK↑	Q	12	20		12	20		ns	
t _{PHL}			17	25		17	25		ns	
t _{PHL}	\overline{CCLR} ↓	Q	R _L = 667 Ω, C _L = 45 pF	23	40					ns
t _{PLH}				R/C	Q	16	25		16	25
t _{PHL}	16	25					16	25		ns
t _{PZH}	\bar{G} ↓	Q		19	30		19	30		ns
t _{PZL}				19	30		19	30		ns
t _{PHZ}	\bar{G} ↑	Q		R _L = 667 Ω, C _L = 5 pF	17	30		17	30	
t _{PLZ}			17		30		17	30		ns

NOTE 6: See General Information Section for load circuits and voltage waveforms.

3

TTL DEVICES

TYPES SN54LS696, SN54LS698, SN74LS696, SN74LS698
 SYNCHRONOUS UP/DOWN COUNTERS
 WITH OUTPUT REGISTERS AND MULTIPLEXED 3-STATE OUTPUTS

typical operating sequences

'LS696 DECADE COUNTER, Asynchronous Clear
 'LS698 DECADE COUNTER, Synchronous Clear

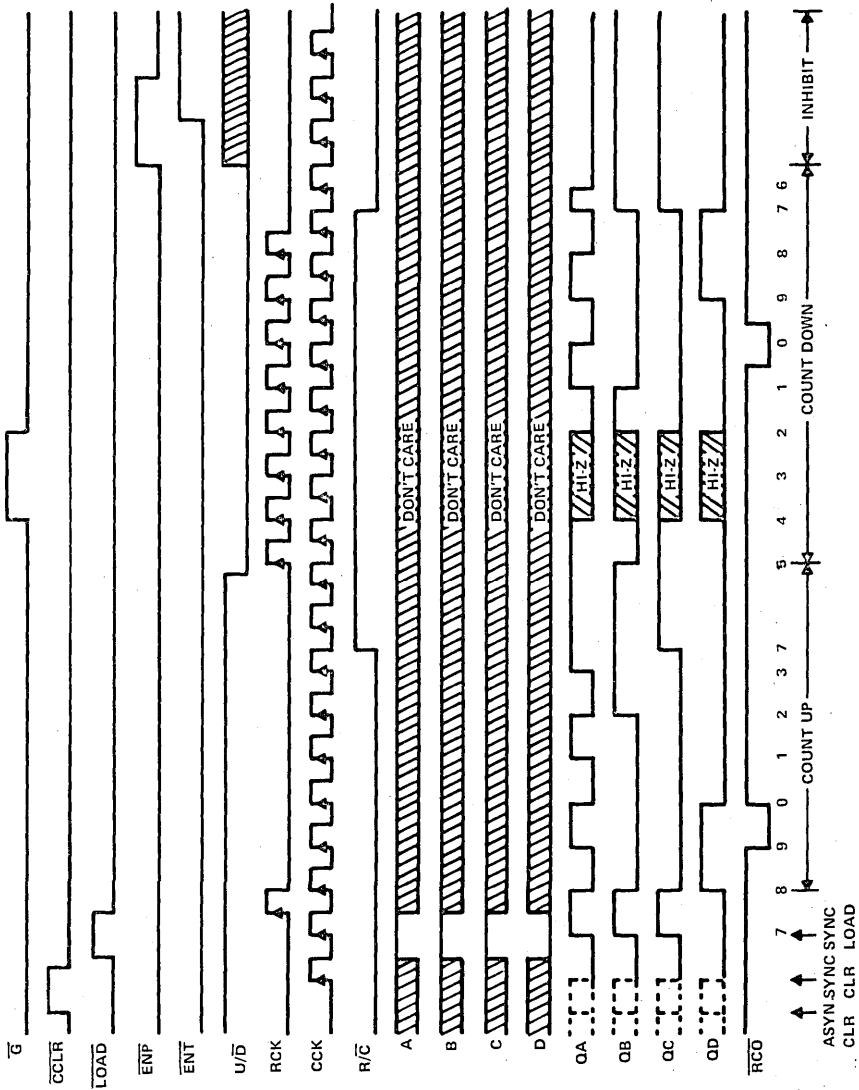

TTL DEVICES

TEXAS INSTRUMENTS

POST OFFICE BOX 225012 • DALLAS, TEXAS 75265

TYPES SN54LS697, SN54LS699, SN74LS697, SN74LS699
 SYNCHRONOUS UP/DOWN COUNTERS
 WITH OUTPUT REGISTERS AND MULTIPLEXED 3-STATE OUTPUTS

typical operating sequences (continued)

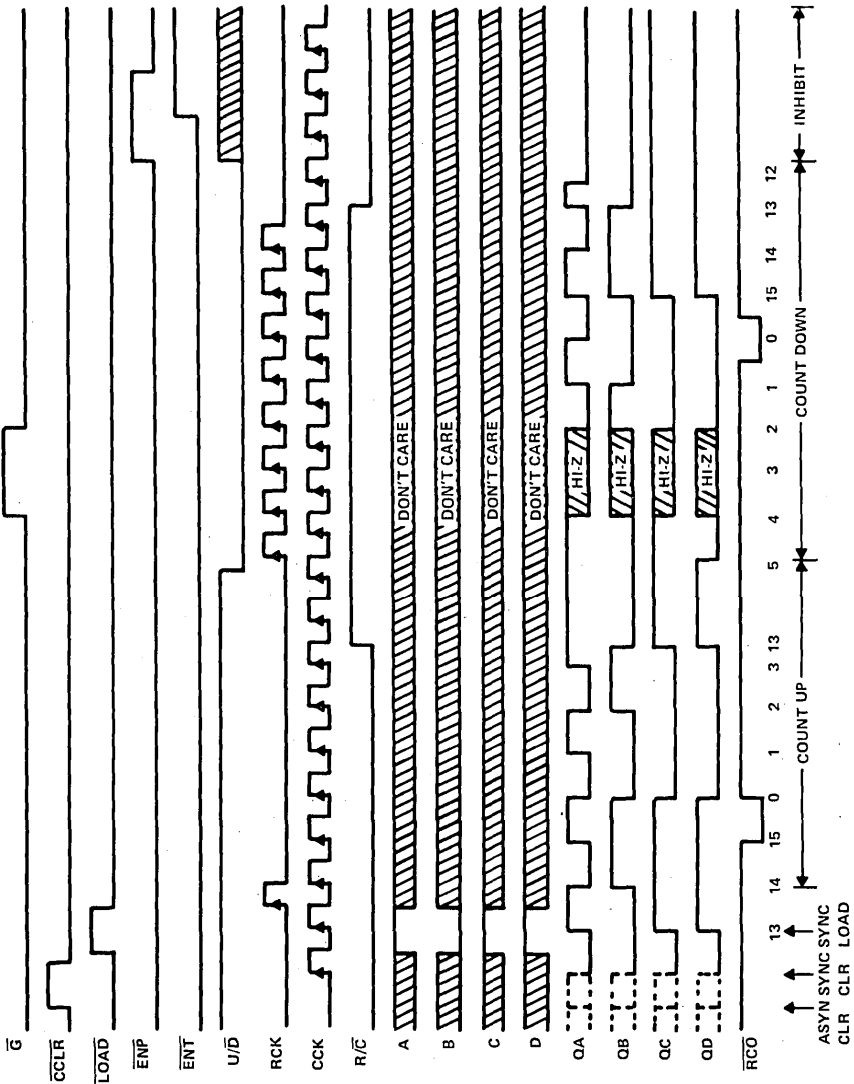

TTL DEVICES

General Information

1

Functional Index

2

TTL Devices

3

Mechanical Data

4

4

MECHANICAL DATA

ORDERING INSTRUCTIONS

Electrical characteristics presented in this data book, unless otherwise noted, apply for circuit type(s) listed in the page heading regardless of package. The availability of a circuit function in a particular package is denoted by an alphabetical reference above the pin-connection diagram(s). These alphabetical references refer to mechanical outline drawings shown in this section.

Factory orders for circuits described in this catalog should include a four-part type number as explained in the following example.

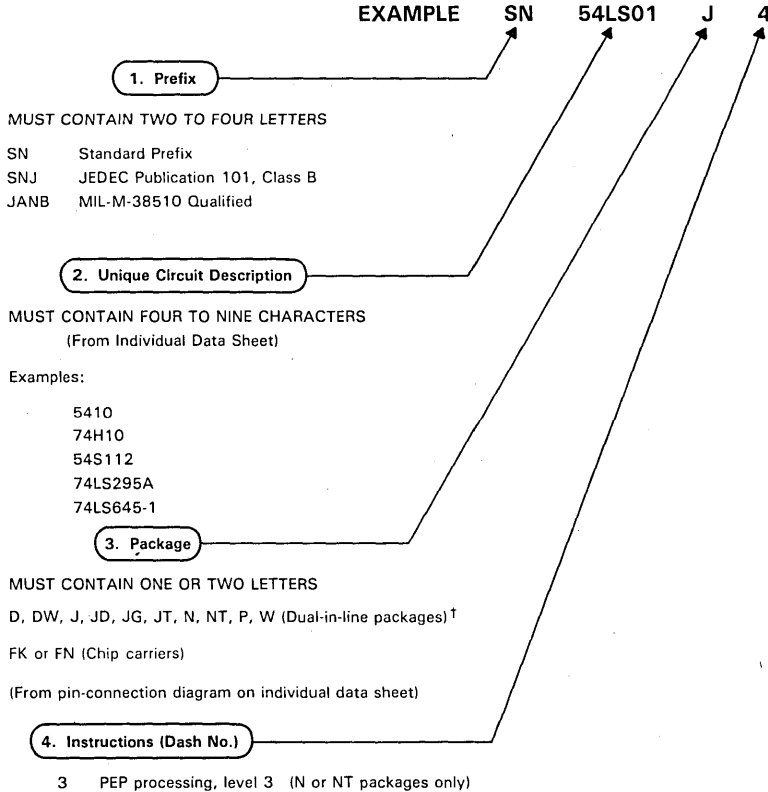

† These circuits in dual-in-line packages are shipped in one of the carriers shown below. Unless a specific method of shipment is specified by the customer (with possible additional costs), circuits will be shipped in the most practical carrier. Please contact your TI sales representative for the method that will best suit your particular needs.

Dual-in-line (D, DW, J, JD, JG, JT, N, NT, P, W)

- A-Channel Plastic Tubing
- Tape and Reel
- Barnes Carrier (W only)



MECHANICAL DATA

D plastic dual-in-line packages

Each of these dual-in-line packages consists of a circuit mounted on a lead frame and encapsulated within a plastic compound. The compound will withstand soldering temperature with no deformation, and circuit performance characteristics will remain stable when operated in high-humidity conditions. Leads require no additional cleaning or processing when used in soldered assembly.

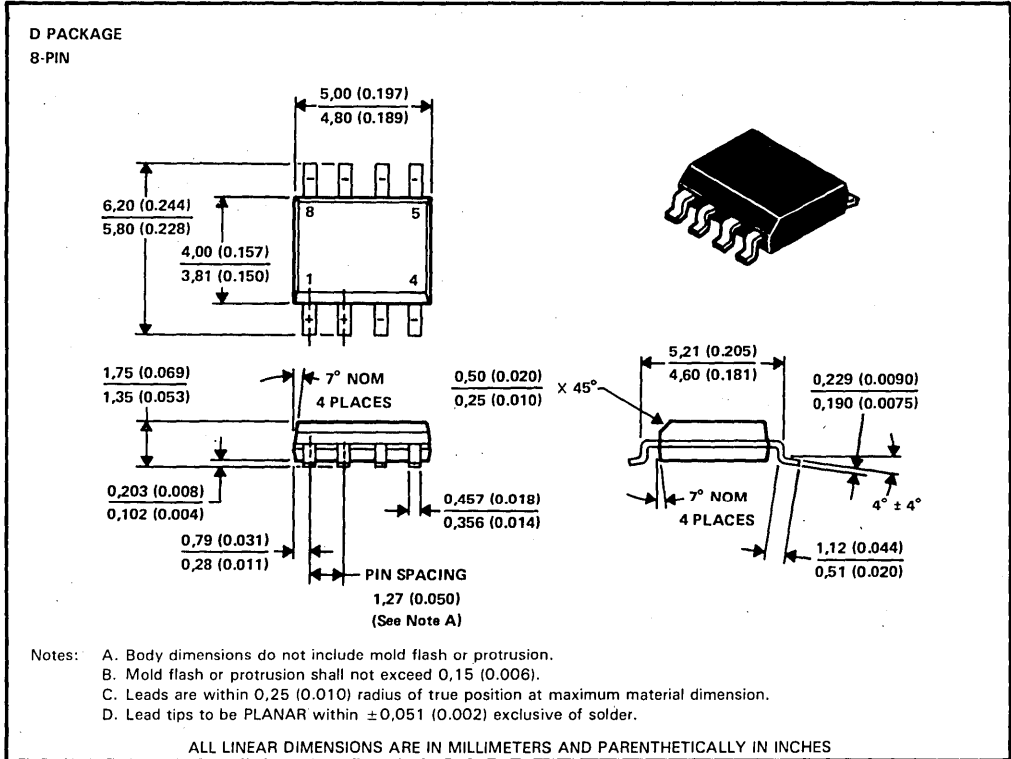

4

MECHANICAL DATA

MECHANICAL DATA

D plastic dual-in-line packages

Each of these dual-in-line packages consists of a circuit mounted on a lead frame and encapsulated within a plastic compound. The compound will withstand soldering temperature with no deformation, and circuit performance characteristics will remain stable when operated in high-humidity conditions. Leads require no additional cleaning or processing when used in soldered assembly.

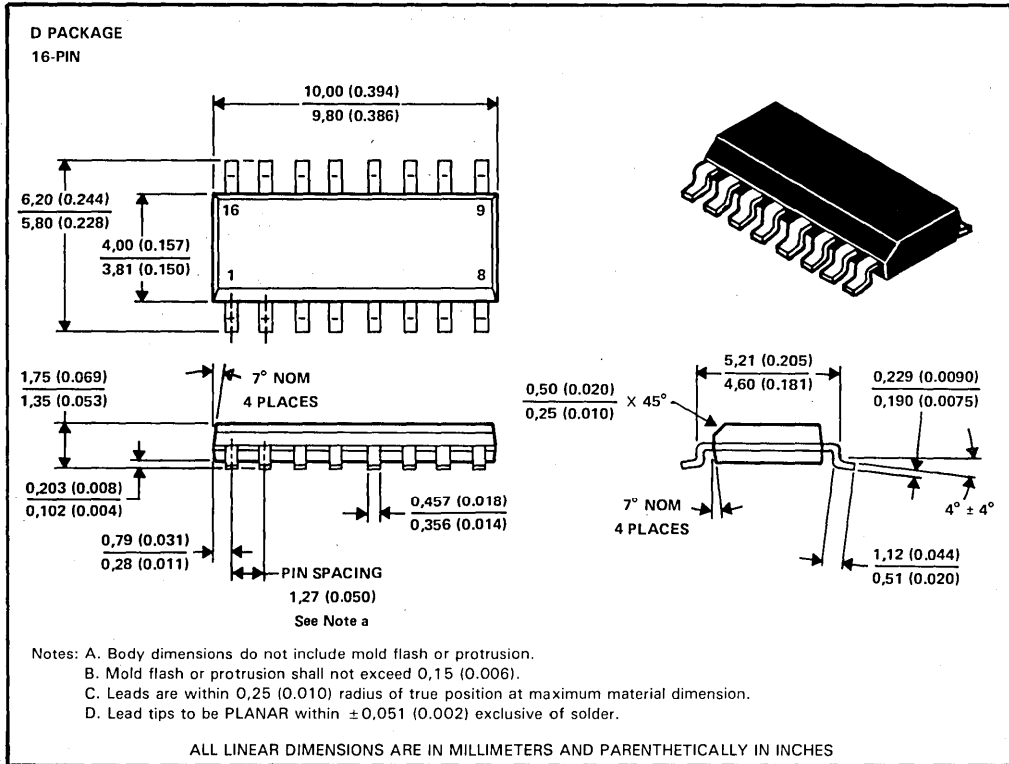

4

MECHANICAL DATA

DW plastic dual-in-line packages

Each of these dual-in-line packages consists of a circuit mounted on a lead frame and encapsulated within a plastic compound. The compound will withstand soldering temperature with no deformation, and circuit performance characteristics will remain stable when operated in high-humidity conditions. Leads require no additional cleaning or processing when used in soldered assembly.

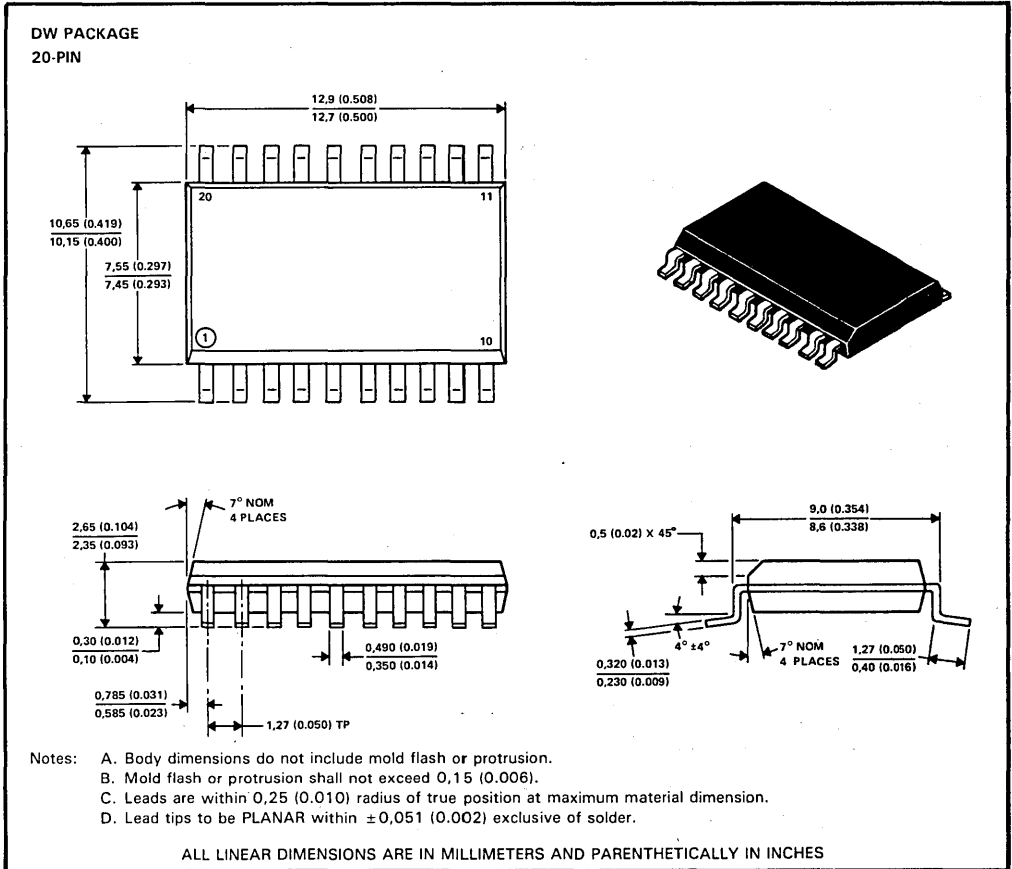

MECHANICAL DATA

DW plastic dual-in-line packages

Each of these dual-in-line packages consists of a circuit mounted on a lead frame and encapsulated within a plastic compound. The compound will withstand soldering temperature with no deformation, and circuit performance characteristics will remain stable when operated in high-humidity conditions. Leads require no additional cleaning or processing when used in soldered assembly.

DW PACKAGE
24-PIN

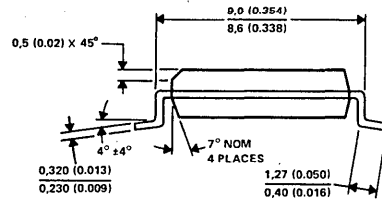
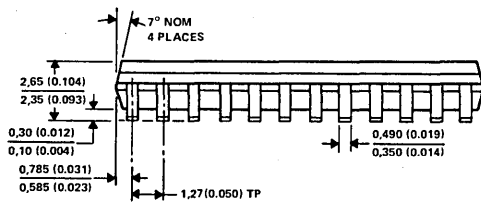
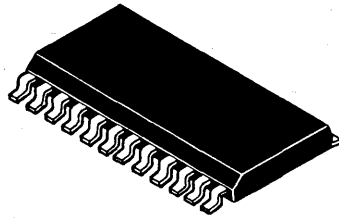
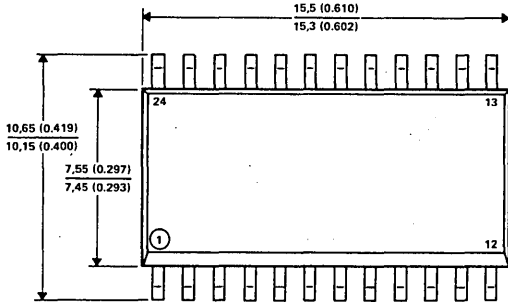

- Notes: A. Body dimensions do not include mold flash or protrusion.
 B. Mold flash or protrusion shall not exceed 0,15 (0.006).
 C. Leads are within 0,25 (0.010) radius of true position at maximum material dimension.
 D. Lead tips to be PLANAR within ±0,051 (0.002) exclusive of solder.

ALL LINEAR DIMENSIONS ARE IN MILLIMETERS AND PARENTHECALLY IN INCHES

4
MECHANICAL DATA

FK ceramic chip carrier packages

Each of these hermetically sealed chip carrier packages has a three-layer ceramic base with a metal lid and braze seal. The packages are intended for surface mounting on solder lands on 1,27 (0.050-inch) centers. terminals require no additional cleaning or processing when used in soldered assembly.

FK package terminal assignments conform to JEDEC Standards 1 and 2.

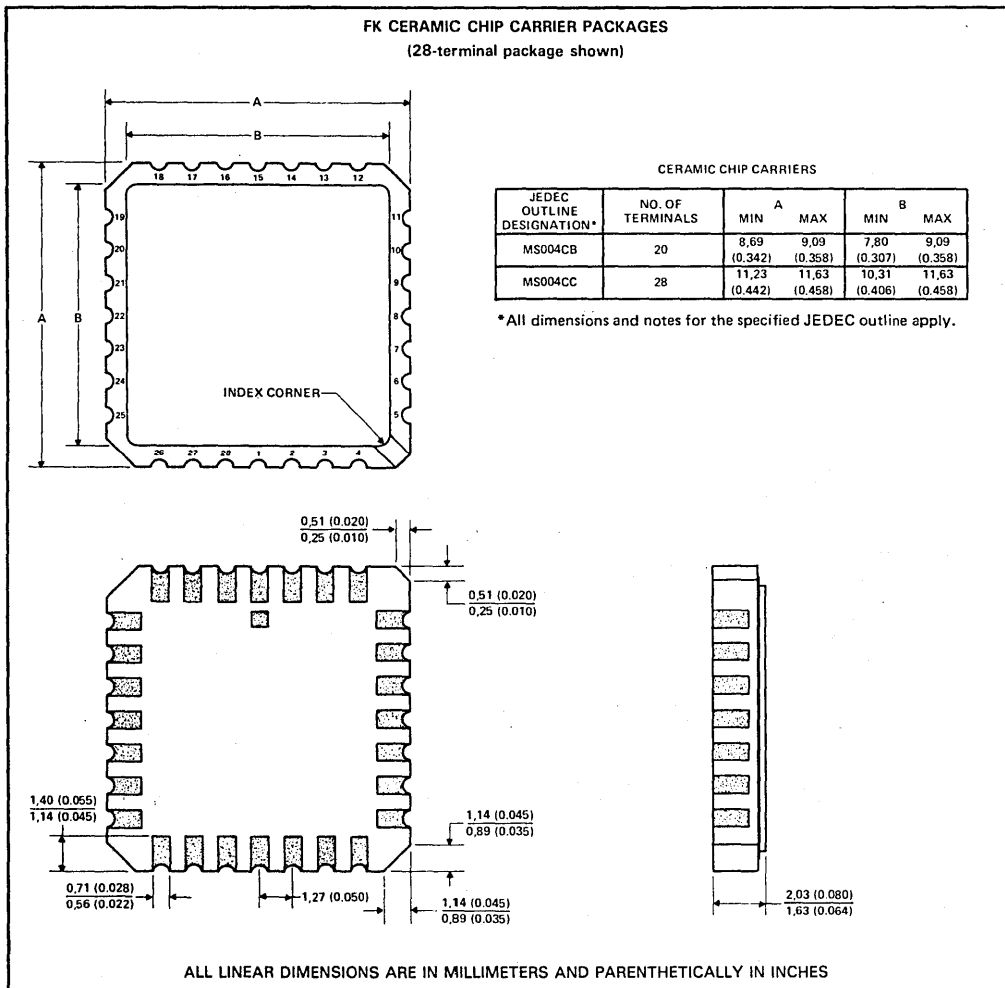

MECHANICAL DATA

FN plastic chip carrier package

Each of these chip carrier packages consists of a circuit mounted on a lead frame and encapsulated within an electrically nonconductive plastic compound. The compound withstands soldering temperatures with no deformation, and circuit performance characteristics remain stable when the devices are operated in high-humidity conditions. The packages are intended for surface mounting on solder lands on 1,27 (0.050) centers. Leads require no additional cleaning or processing when used in soldered assembly.

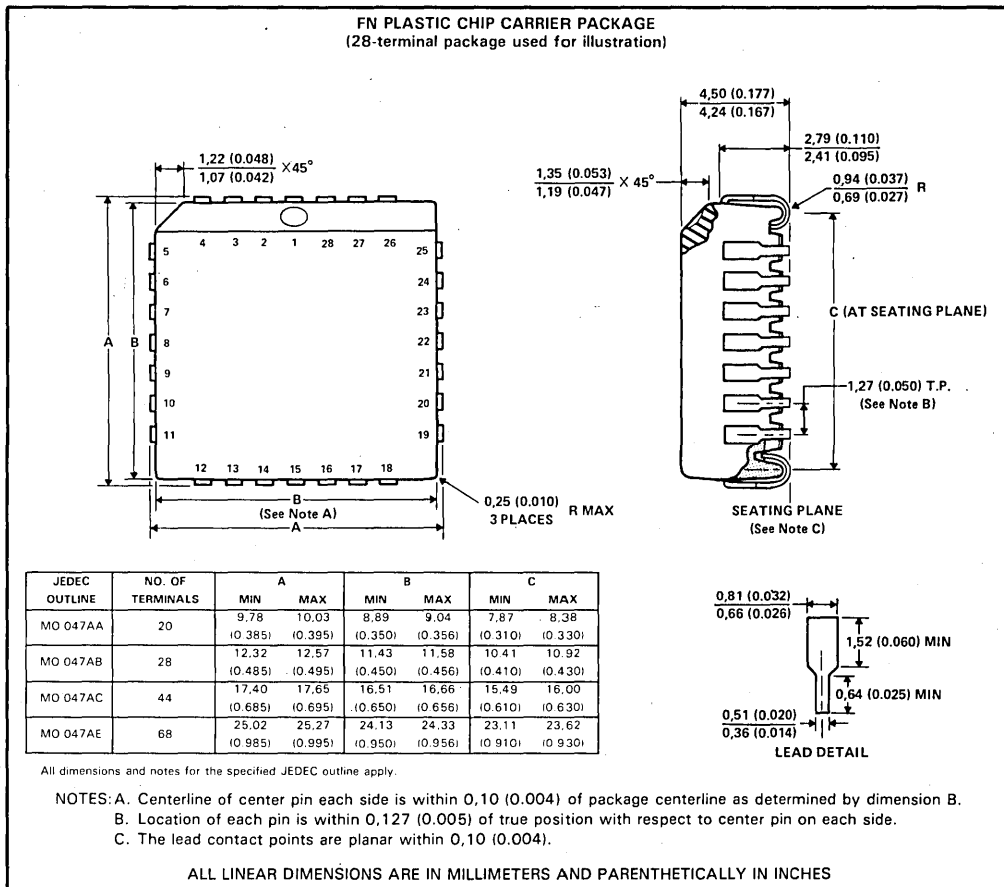

4

MECHANICAL DATA

J ceramic packages (including JT dual-in-line package)

Each of these hermetically sealed dual-in-line packages consists of a ceramic base, ceramic cap, and a lead frame. Hermetic sealing is accomplished with glass. The JT packages are intended for insertion in mounting-hole rows on 7,62 (0.300) centers. Once the leads are compressed and inserted sufficient tension is provided to secure the package in the board during soldering. Tin-plated ("bright-dipped") leads require no additional cleaning or processing when used in soldered assembly.

NOTE: For the 14-, 16-, and 20-pin packages, the letter J is used by itself since these packages are available only in the 7,62 (0.300) row spacing. For the 24-pin packages, if no second letter or row spacing is specified, the package is assumed to have 15,24 (0.600) row spacing.

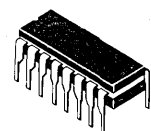
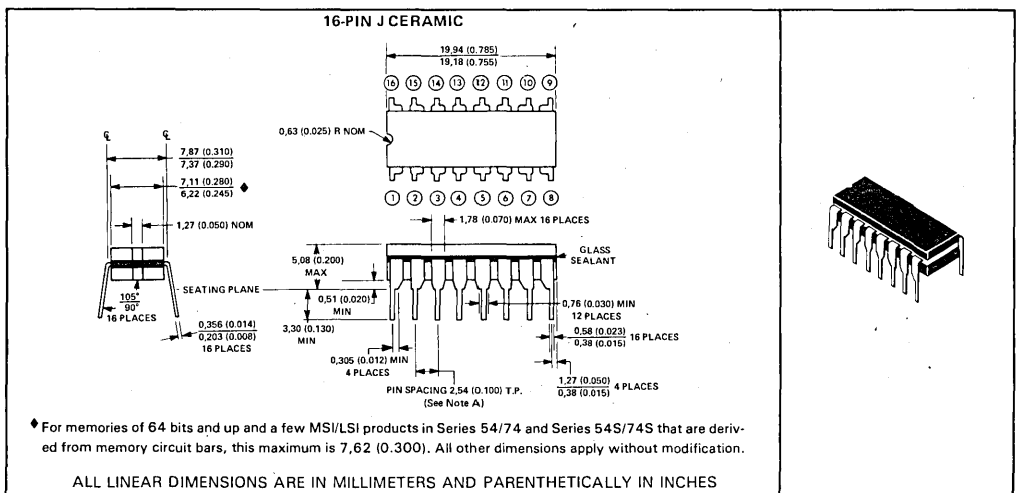
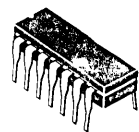
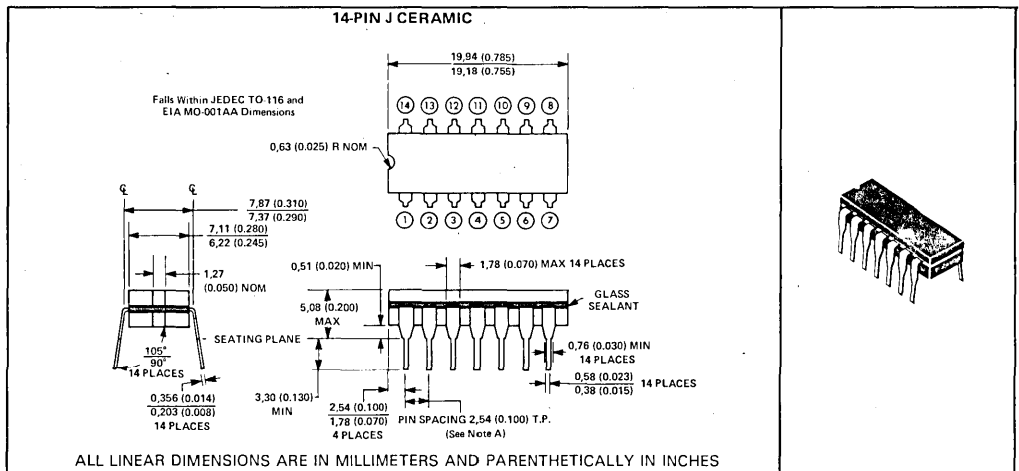

NOTE A: Each pin centerline is located within 0,25 (0.010) of its true longitudinal position.

MECHANICAL DATA

J ceramic dual-in-line packages (continued)

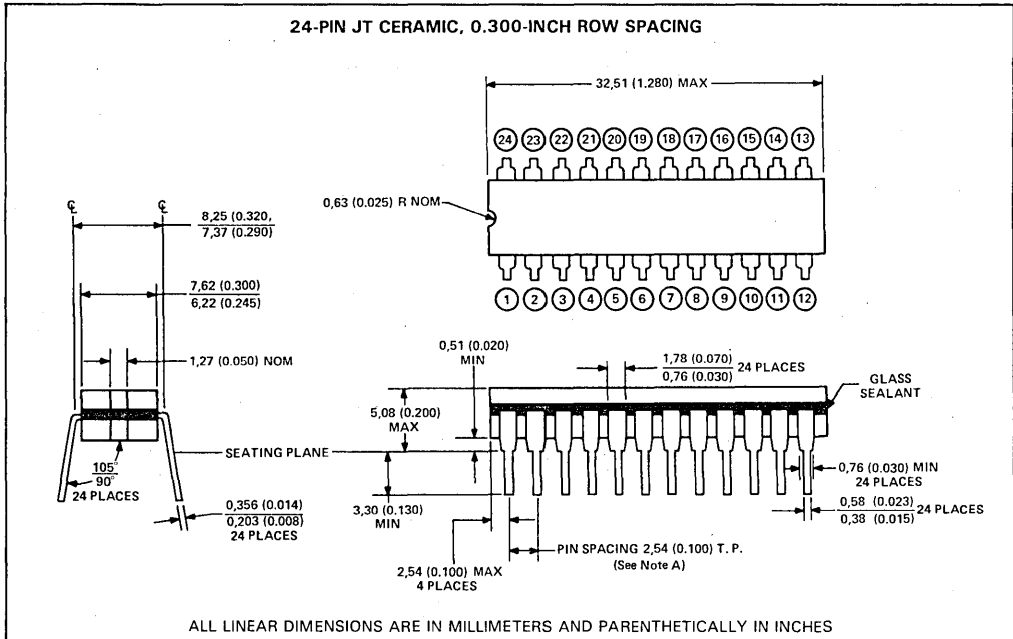
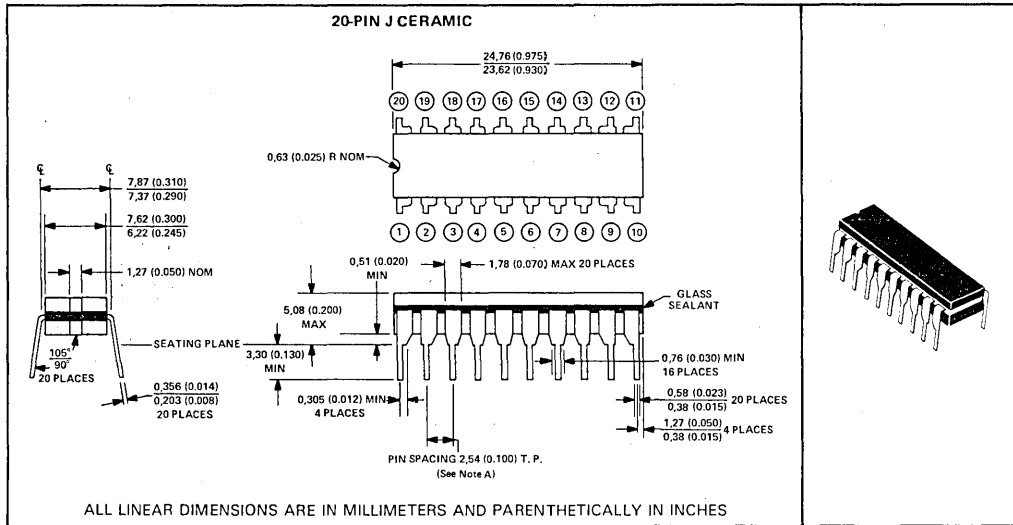

NOTE A: Each pin centerline is located within 0,25 (0.010) of its true longitudinal position.

4 MECHANICAL DATA

J ceramic dual-in-line packages (continued)

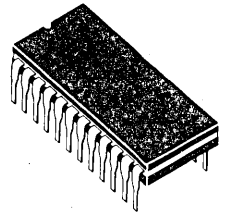
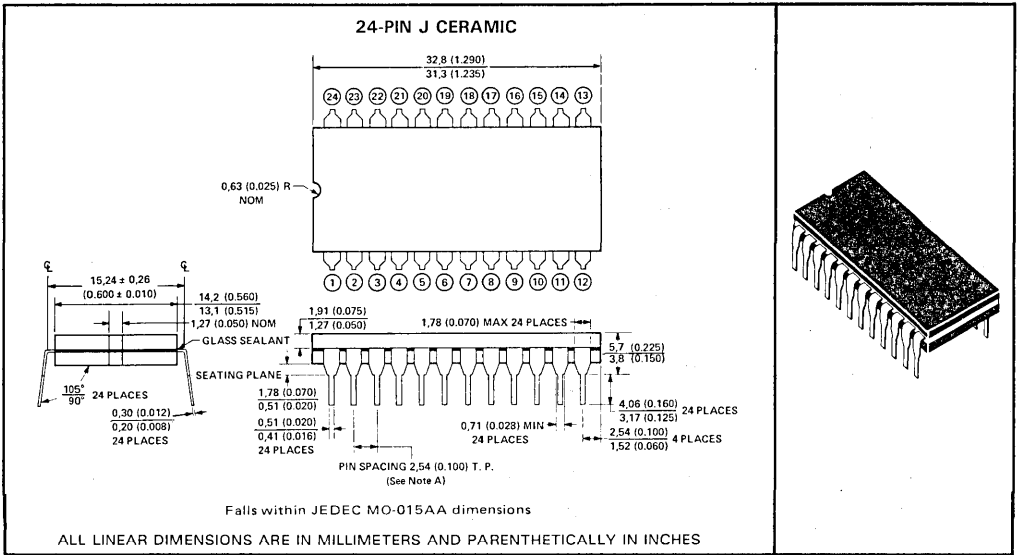

NOTE A: Each pin centerline is located within 0,25 (0.010) of its true longitudinal position.

MECHANICAL DATA

ceramic packages – side-braze (JD suffix)

This is a hermetically sealed ceramic package with a metal cap and side-brazed tin-plated leads.

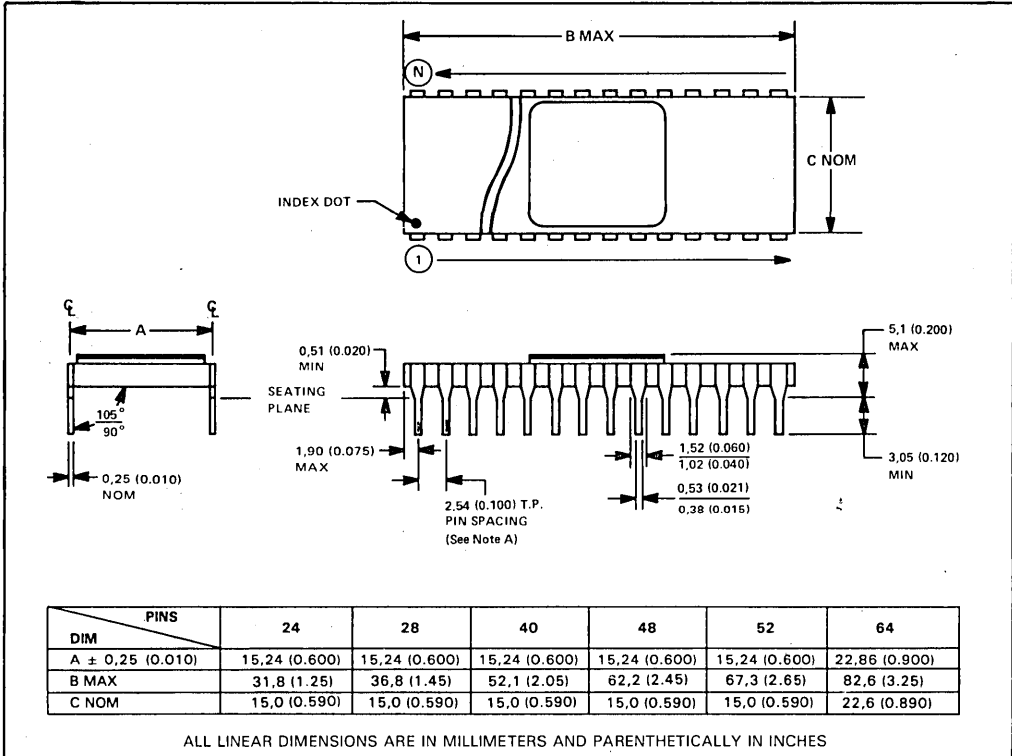

NOTE A: Each pin centerline is located within 0,25 (0.010) of its true longitudinal position.

4

MECHANICAL DATA

JG ceramic dual-in-line package

This hermetically sealed dual-in-line package consists of a ceramic base, ceramic cap, and 8-lead frame. Hermetic sealing is accomplished with glass. The package is intended for insertion in mounting-hole rows on 7,62 (0.300) centers (see Note a). Once the leads are compressed and inserted, sufficient tension is provided to secure the package in the board during soldering. Non-shiny tin-plated leads require no additional cleaning or processing when used in soldered assembly.

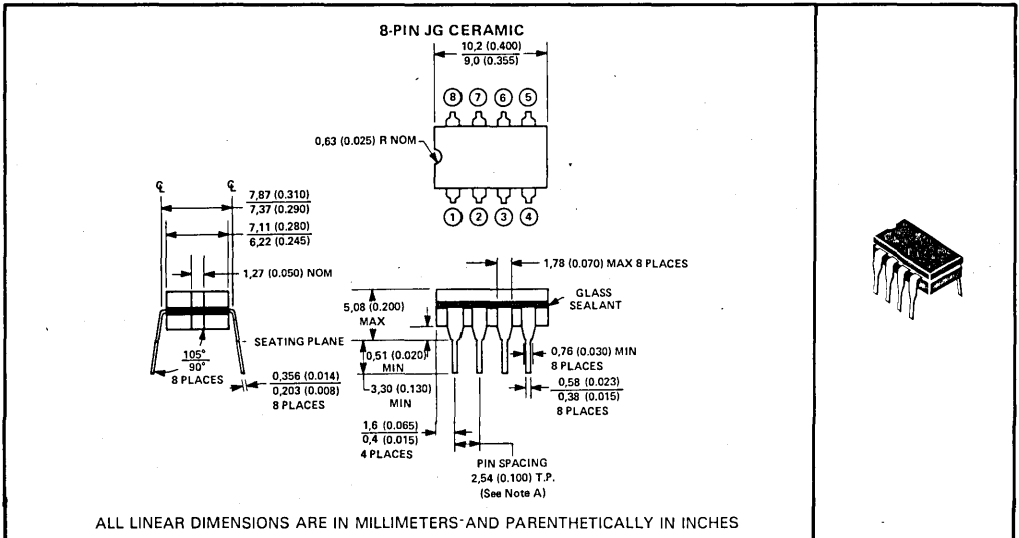

NOTE A: Each pin centerline is located within 0.25 (0.010) of its true longitudinal position.

MECHANICAL DATA

N plastic packages (including NT dual-in-package)

Each of these dual-in-line packages consists of a circuit mounted on a lead frame and encapsulated within an electrically nonconductive plastic compound. The compound will withstand soldering temperature with no deformation and circuit performance characteristics remain stable when operated in high-humidity conditions. The packages are intended for insertion in mounting-hole rows on 7,62 (0.300) centers for the NT package. Once the leads are compressed and inserted, sufficient tension is provided to secure the package in the board during soldering. Leads require no additional cleaning or processing when used in soldered assembly.

NOTE: For the 14-, 16-, 20-, and 28-pin packages, the letter N is used by itself since these packages are available in only one row-spacing width - 7,62 (0.300) for the 14-, 16-, 18-, and 20-pin packages and 15,24 (0.600) for the 28-pin package. For the 24-pin package, if no second letter or row spacing is specified, the package is assumed to have 15,24 (0.600) row spacing.

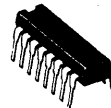
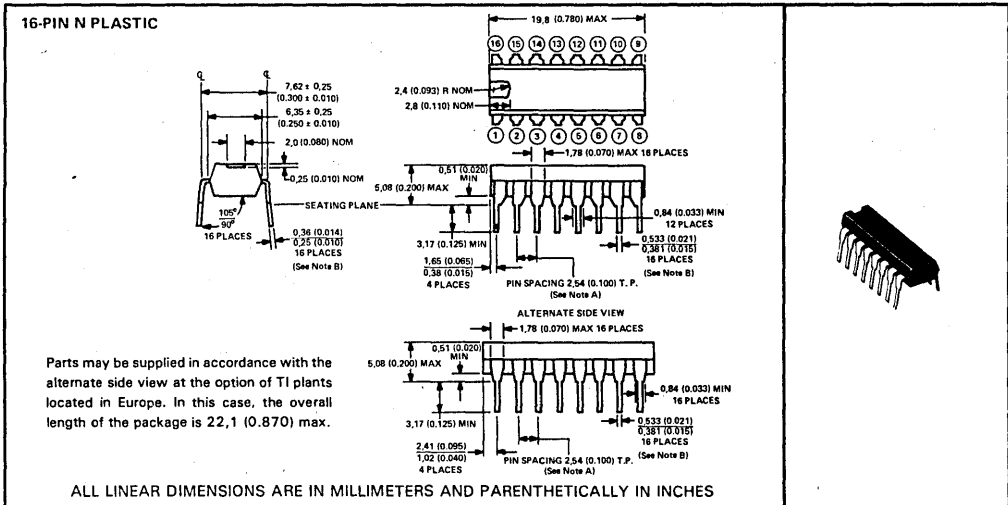
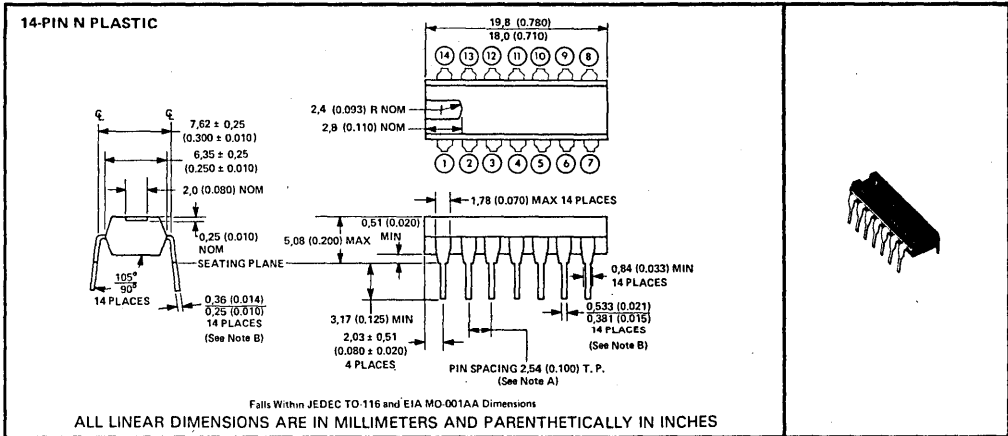

NOTES:A. Each pin centerline is located within 0,25 (0.010) of its true longitudinal position.
 B. For solder-dipped leads, this dimension applies from the lead tip to the standoff.

4

MECHANICAL DATA

N package

N PACKAGE
20-PIN

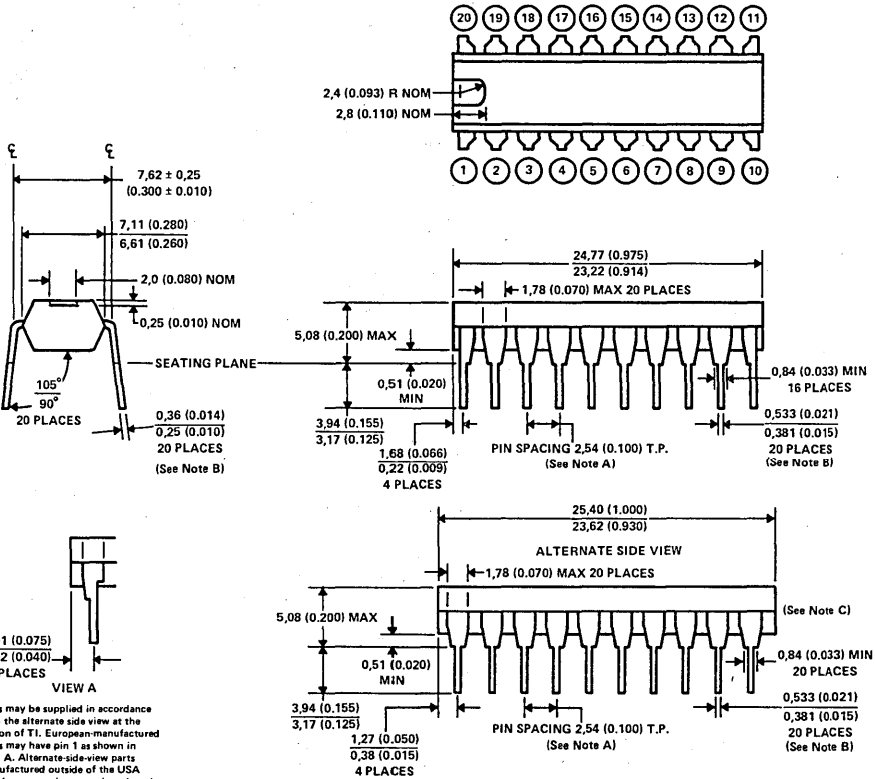

Parts may be supplied in accordance with the alternate side view at the option of TI. European-manufactured parts may have pin 1 as shown in view A. Alternate-side-view parts manufactured outside of the USA may have a maximum package length of 26,7 (1,050).

- NOTES: A. Each pin centerline is located within 0,25 (0,010) of its true longitudinal position.
 B. For solder dipped leads, this dimension applies from the lead tip to the standoff.
 C. Parts may be supplied with a draft angle of 7° typical at the option of TI.

ALL LINEAR DIMENSIONS ARE IN MILLIMETERS AND PARENTHEMICALLY IN INCHES

N plastic dual-in-line packages (continued)

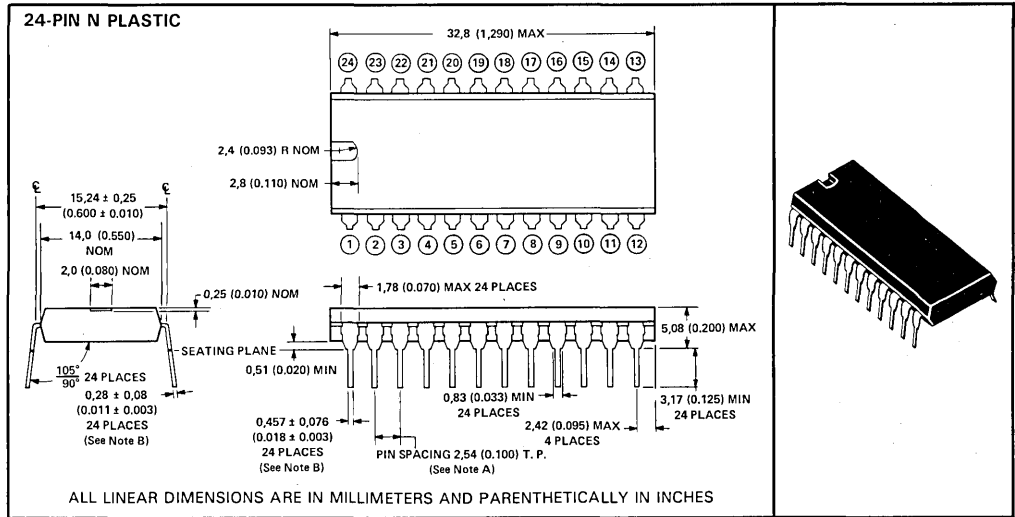

NOTES: A. Each pin centerline is located within 0,25 (0,010) of its true longitudinal position.
 B. For solder-dipped leads, this dimension applies from the lead tip to the standoff.

28-PIN N PLASTIC

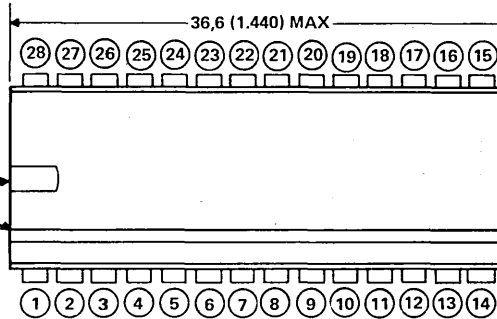
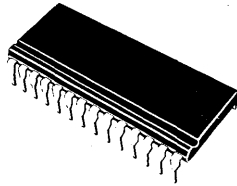

EITHER INDEX

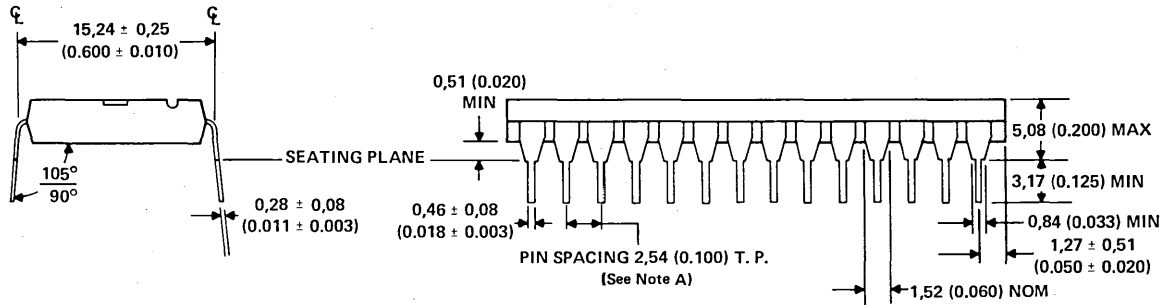

ALL LINEAR DIMENSIONS ARE IN MILLIMETERS AND PARENTHETICALLY IN INCHES

NOTE A: Each pin centerline is located within 0,25 (0.010) of its true longitudinal position.

N plastic packages (continued)

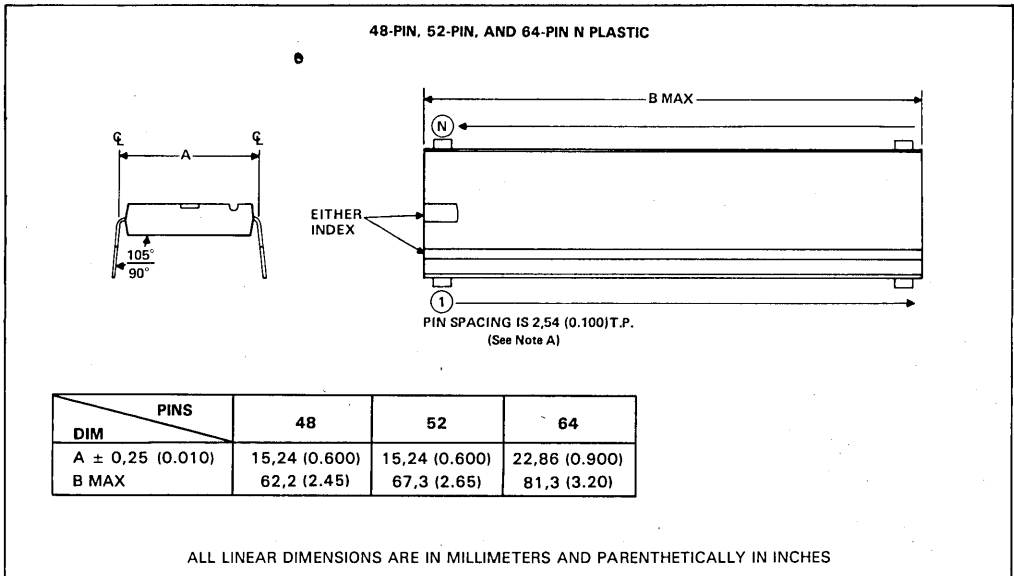
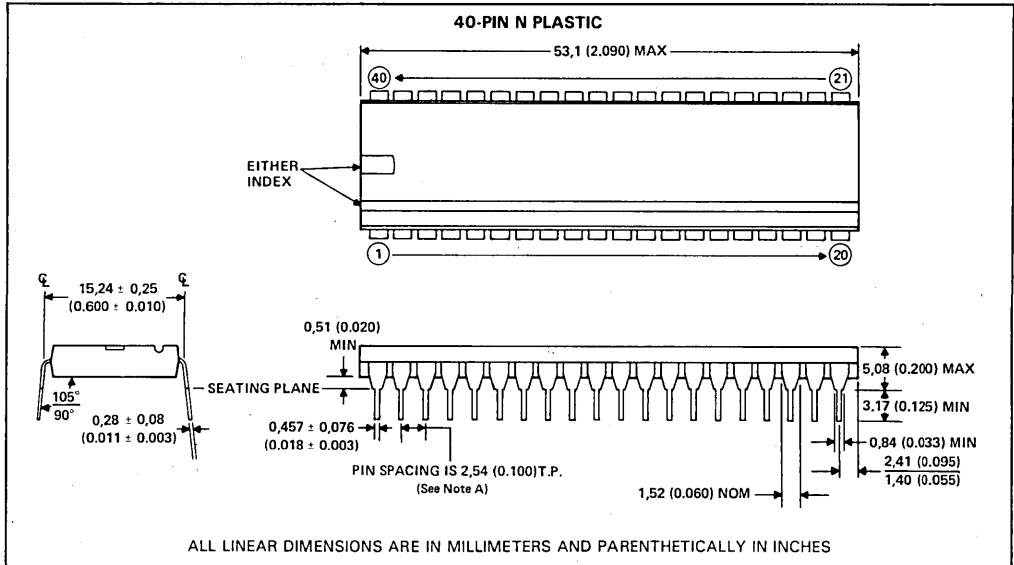

NOTE A: Each pin centerline is located within 0,25 (0.010) of its true longitudinal position.

4
MECHANICAL DATA

MECHANICAL DATA

P plastic dual-in-line package

This dual-in-line package consists of a circuit mounted on an 8-lead frame and encapsulated within a plastic compound. The compound will withstand soldering temperature with no deformation and circuit performance characteristics remain stable when operated in high-humidity conditions. The package is intended for insertion in mounting-hole rows on 7,62-mm (0.300) centers (see Note A). Once the leads are compressed and inserted, sufficient tension is provided to secure the package in the board during soldering. Solder-plated leads require no additional cleaning or processing when used in soldered assembly.

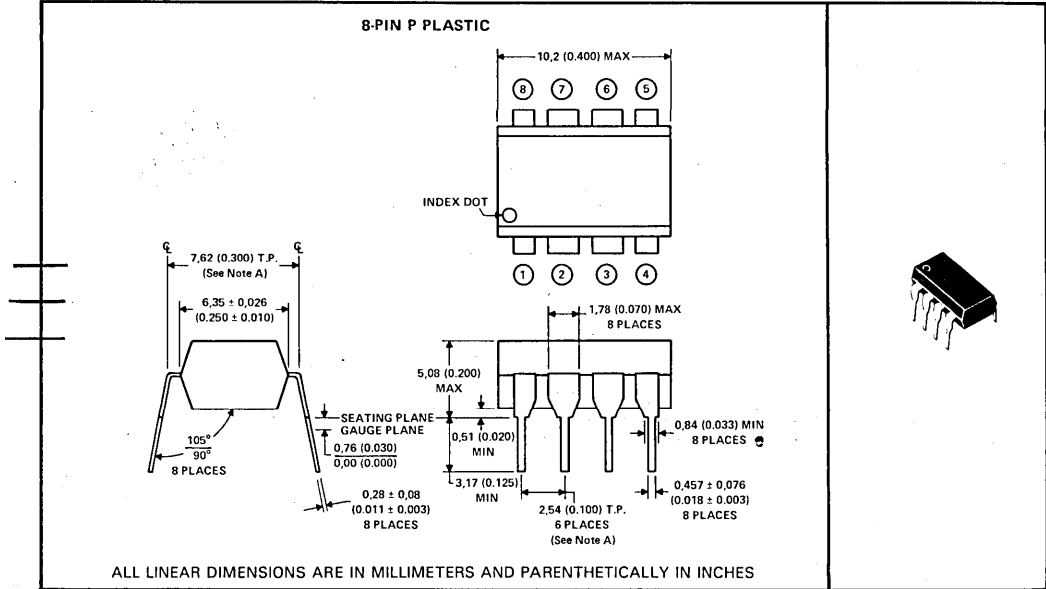

4

NOTE A: Each pin is within 0,13 (0.0005) radius of true position (TP) at the gauge plane with maximum material condition and unit installed.

MECHANICAL DATA

W ceramic flat packages

These hermetically sealed flat packages consist of an electrically nonconductive ceramic base and cap and a lead frame. Hermetic sealing is accomplished with glass. Leads require no additional cleaning or processing when used in soldered assembly.

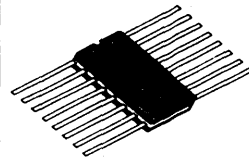
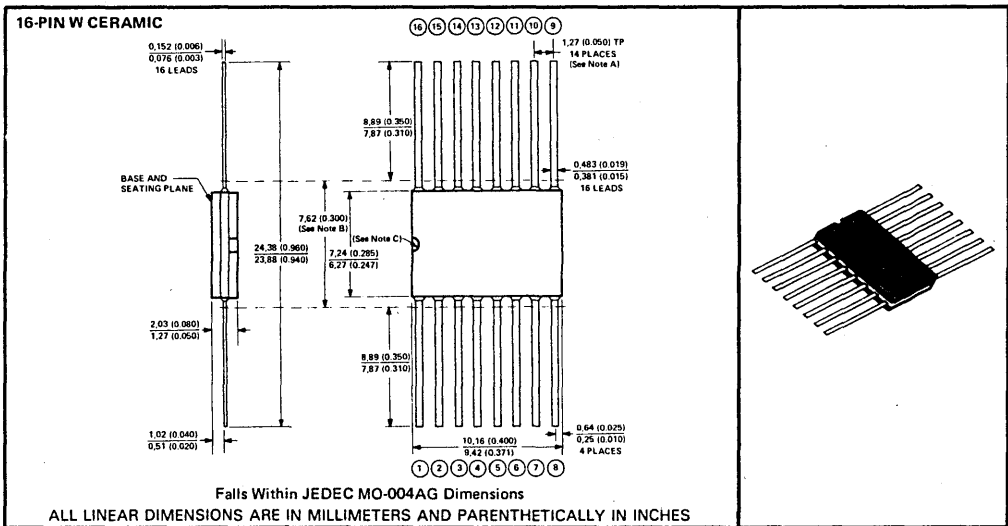
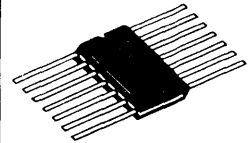
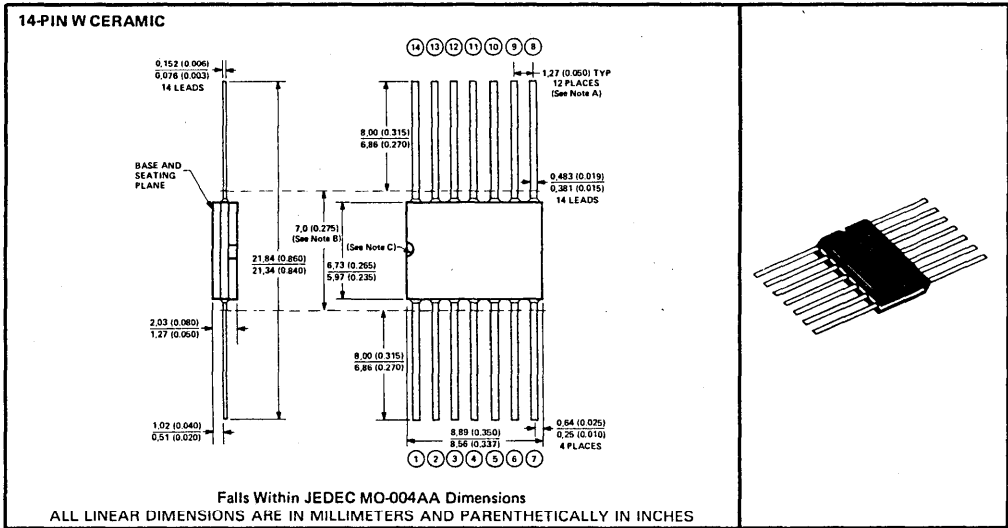

- NOTES: A. Leads are within 0,13 (0.005) radius of true position (TP) at maximum material condition.
B. This dimension determines a zone within which all body and lead irregularities lie.
C. Index point is provided on cap for terminal identification only.

MECHANICAL DATA

W ceramic flat package (continued)

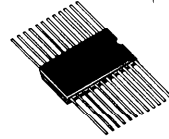
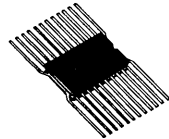
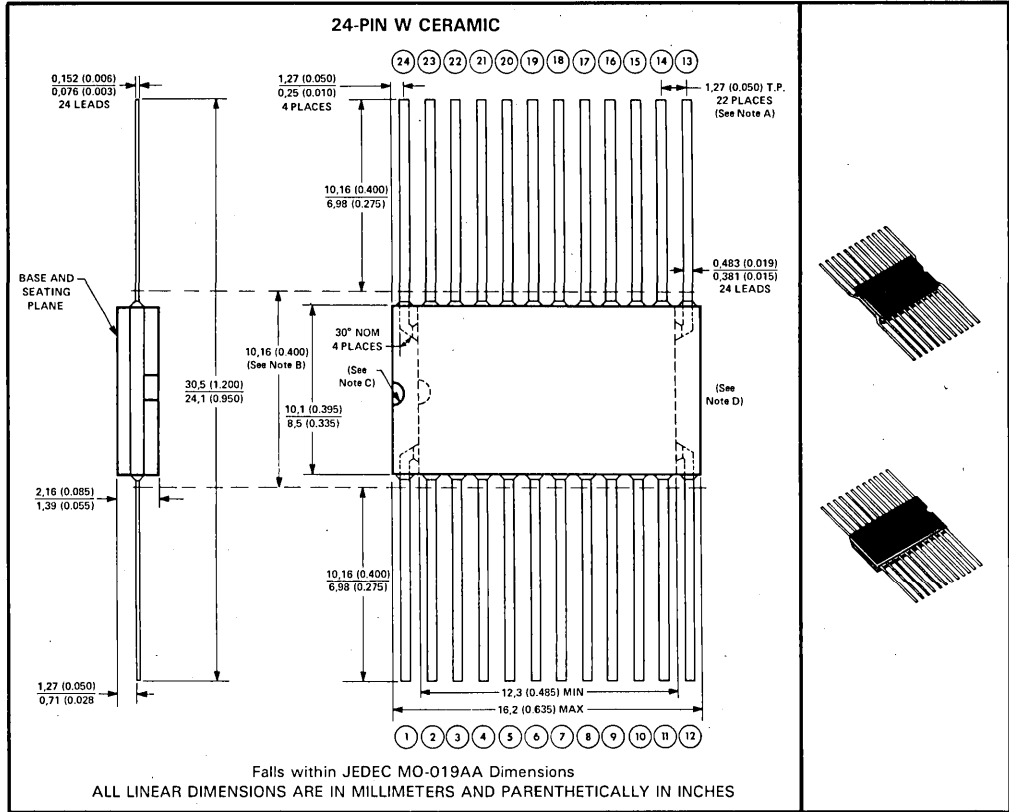

- NOTES:
- A. Leads are within 0,13 (0.005) radius of true position (TP) at maximum material condition.
 - B. This dimension determines a zone within which all body and lead irregularities lie.
 - C. Index point is provided on cap for terminal identification only.
 - D. End configuration of 24-pin package is at the option of TI.

4

MECHANICAL DATA

TI Sales Offices

ALABAMA: Huntsville (205) 837-7530
ARIZONA: Phoenix (602) 995-1007.
CALIFORNIA: Irvine (714) 660-8187.
 Sacramento (916) 929-1521.
 San Diego (619) 278-9601.
 Santa Clara (408) 990-9000.
 Torrance (213) 217-7010.
 Woodland Hills (818) 704-7759.
COLORADO: Aurora (303) 368-8000
CONNECTICUT: Wallingford (203) 269-0074
FLORIDA: Ft. Lauderdale (305) 973-8502.
 Maitland (305) 660-4600. Tampa (813) 870-6420
GEORGIA: Norcross (404) 662-7900.
ILLINOIS: Arlington Heights (312) 640-2925.
INDIANA: Ft. Wayne (219) 424-5174.
 Indianapolis (317) 248-8555
IOWA: Cedar Rapids (319) 395-9550
MARYLAND: Baltimore (301) 944-8600
MASSACHUSETTS: Waltham (617) 895-9100
MICHIGAN: Farmington Hills (313) 553-1500
MINNESOTA: Eden Prairie (612) 828-9300
MISSOURI: Kansas City (816) 523-2500.
 St. Louis (314) 569-7600
NEW JERSEY: Iselin (201) 750-1050.
NEW MEXICO: Albuquerque (505) 345-2555.
NEW YORK: East Syracuse (315) 463-9291.
 Endicott (607) 754-3900. Melville (516) 454-6600.
 Pittsford (716) 385-6770.
 Poughkeepsie (914) 473-2900
NORTH CAROLINA: Charlotte (704) 527-0930.
 Raleigh (919) 876-2725
OHIO: Beachwood (216) 464-6100.
 Dayton (513) 258-3877
OKLAHOMA: Tulsa (918) 250-0633.
OREGON: Beaverton (503) 643-6758
PENNSYLVANIA: Ft. Washington (215) 643-6450.
 Coraopolis (412) 771-8550
PUERTO RICO: Hato Rey (809) 753-8700
TEXAS: Austin (512) 250-7655.
 Houston (713) 778-6592. Richardson (214) 680-5082.
 San Antonio (512) 496-1779
UTAH: Murray (801) 266-8972
VIRGINIA: Fairfax (703) 849-1400
WASHINGTON: Redmond (206) 881-3080
WISCONSIN: Brookfield (414) 785-7140
CANADA: Nepean, Ontario (613) 726-1970.
 Richmond Hill, Ontario (416) 884-9181.
 St. Laurent, Quebec (514) 334-3635

TI Regional Technology Centers

CALIFORNIA: Irvine (714) 660-8140.
 Santa Clara (408) 748-2220
GEORGIA: Norcross (404) 662-7945.
ILLINOIS: Arlington Heights (312) 640-2909
MASSACHUSETTS: Waltham (617) 890-6671
TEXAS: Richardson (214) 680-5066
CANADA: Nepean, Ontario (613) 726-1970

Technical Support Center

TOLL FREE: (800) 232-3200

TI Distributors

TI AUTHORIZED DISTRIBUTORS IN USA

Arrow Electronics
 Diplomat Electronics
 General Radio Supply Company
 Graham Electronics
 Harrison Equipment Co.
 International Electronics
 JACO Electronics
 Kierulff Electronics
 LCOMP, Incorporated
 Marshall Industries
 Milgray Electronics
 Newark Electronics
 Rochester Radio Supply
 Time Electronics
 R.V. Weatherford Co.
 Wyle Laboratories

TI AUTHORIZED DISTRIBUTORS IN CANADA

Arrow/CESCO Electronics, Inc.
 Future Electronics
 ITT Components
 L.A. Varah, Ltd.

ALABAMA: Arrow (205) 882-2730.
 Kierulff (205) 883-6070. Marshall (205) 881-9235
ARIZONA: Arrow (602) 968-4800.
 Kierulff (602) 243-4101. Marshall (602) 968-6181.
 Wyle (502) 866-2688
CALIFORNIA: Los Angeles/Orange County:
 Arrow (818) 701-7500. (714) 838-5422.
 Kierulff (213) 725-0325. (714) 731-5711. (714) 220-6300.
 Marshall (818) 989-5001. (818) 442-7204.
 (714) 660-0951. R.V. Weatherford (714) 634-9600.
 (213) 849-3451. (714) 623-1261. Wyle (213) 322-8100.
 (818) 880-9001. (714) 863-9953. Sacramento: Arrow
 (916) 925-7456. Wyle (916) 638-5282. San Diego:
 Arrow (619) 565-4800. Kierulff (619) 278-2112.
 Marshall (619) 578-9600. Wyle (619) 565-9171.
 San Francisco Bay Area: Arrow (408) 745-6600.
 (415) 487-4600. Kierulff (408) 971-2600.
 Marshall (408) 732-1100. Wyle (408) 727-2500.
 Santa Barbara: R.V. Weatherford (805) 965-8551.
COLORADO: Arrow (303) 696-1111.
 Kierulff (303) 790-4444. Wyle (303) 457-9953
CONNECTICUT: Arrow (203) 265-7741.
 Diplomat (203) 797-9674. Kierulff (203) 265-1115.
 Marshall (203) 265-3822. Milgray (203) 795-0714.
FLORIDA: Ft. Lauderdale: Arrow (305) 429-8200.
 Diplomat (305) 974-8700. Kierulff (305) 486-4004.
 Orlando: Arrow (305) 725-1480.
 Milgray (305) 647-5747. Tampa:
 Arrow (813) 576-8955. Diplomat (813) 443-4514.
 Kierulff (813) 576-1966.
GEORGIA: Arrow (404) 449-8252.
 Kierulff (404) 447-5252. Marshall (404) 923-5750.

ILLINOIS: Arrow (312) 397-3440.
 Diplomat (312) 555-1000. Kierulff (312) 250-0500.
 Marshall (312) 490-0155. Newark (312) 784-5100.

INDIANA: Indianapolis: Arrow (317) 243-9353.
 Graham (317) 634-8202. Marshall (317) 297-0483.
 Ft. Wayne: Graham (219) 423-3422.

IOWA: Arrow (319) 395-7230

KANSAS: Kansas City: Marshall (913) 492-3121.
 Wichita: LCOMP (316) 265-9507.

MARYLAND: Arrow (301) 995-0003.
 Diplomat (301) 995-1226. Kierulff (301) 636-5800.
 Milgray (301) 793-3993.

MASSACHUSETTS: Arrow (617) 933-8130.
 Diplomat (617) 935-6611. Kierulff (617) 667-8331.
 Marshall (617) 272-8200. Time (617) 935-8086.

MICHIGAN: Detroit: Arrow (313) 971-8220.
 Marshall (313) 525-5850. Newark (313) 967-0600.
 Grand Rapids: Arrow (616) 243-0912.

MINNESOTA: Arrow (612) 930-1800.
 Kierulff (612) 941-7500. Marshall (612) 559-2211.

MISSOURI: Kansas City: LCOMP (816) 221-2400.
 St. Louis: Arrow (314) 567-6888.
 Kierulff (314) 739-0855.

NEW HAMPSHIRE: Arrow (603) 668-6968

NEW JERSEY: Arrow (201) 575-5300. (609) 596-8000.
 Diplomat (201) 785-1830.
 General Radio (609) 964-8560. Kierulff (201) 575-6750.
 (609) 235-1444. Marshall (201) 882-0320.
 (609) 234-9100. Milgray (609) 983-5010.

NEW MEXICO: Arrow (505) 243-4566.
 International Electronics (505) 345-8127.

NEW YORK: Long Island: Arrow (516) 231-1000.
 Diplomat (516) 454-8400. JACO (516) 273-5500.
 Marshall (516) 273-2053. Milgray (516) 420-9800.
 Rochester: Arrow (716) 427-0300.
 Marshall (716) 235-7620.
 Rochester Radio Supply (716) 454-7800.
 Syracuse: Arrow (315) 652-1000.
 Diplomat (315) 652-5000. Marshall (607) 798-1611.

NORTH CAROLINA: Arrow (919) 876-3132.
 (919) 725-8711. Kierulff (919) 872-8410.

OHIO: Cincinnati: Graham (513) 772-1661.
 Cleveland: Arrow (216) 248-3930.
 Kierulff (216) 587-6558. Marshall (216) 248-1788.
 Columbus: Graham (614) 895-1590.
 Dayton: Arrow (513) 435-5563. Kierulff (513) 439-0045.
 Marshall (513) 236-8088.

OKLAHOMA: Kierulff (918) 252-7537

OREGON: Arrow (503) 684-1690. Kierulff
 (503) 641-9153. Wyle (503) 640-6000. Marshall
 (503) 644-5050.

PENNSYLVANIA: Arrow (412) 856-7000.
 (215) 928-1800. General Radio (215) 922-7037.

RHODE ISLAND: Arrow (401) 431-0980

TEXAS: Austin: Arrow (512) 835-4180.
 Kierulff (512) 835-2090. Marshall (512) 837-1991.
 Wyle (512) 834-9957. Dallas: Arrow (214) 380-6844.
 International Electronics (214) 233-9323.
 Kierulff (214) 343-2400. Marshall (214) 233-5200.
 Wyle (214) 235-9533.

El Paso: International Electronics (915) 598-3406.
 Houston: Arrow (713) 530-4700.
 Marshall (713) 789-6600.

Harrison Equipment (713) 879-2600.
 Kierulff (713) 530-7030. Wyle (713) 879-9953.

UTAH: Diplomat (801) 486-4134.
 Kierulff (801) 973-6913. Wyle (801) 974-9953.

VIRGINIA: Arrow (804) 282-0413

WASHINGTON: Arrow (206) 643-4800.
 Kierulff (206) 575-4420. Wyle (206) 453-8300. Marshall
 (206) 747-9100.

WISCONSIN: Arrow (414) 764-6600. Kierulff
 (414) 784-8160.

CANADA: Calgary: Future (403) 235-5325. Varah
 (403) 255-9550. Edmonton: Future (403) 486-0974.
 Varah (403) 437-2750. Montreal: Arrow/CESCO
 (514) 735-5511. Future (514) 684-7710. ITT
 Components (514) 735-1177. Ottawa: Arrow/CESCO
 (613) 226-6903. Future (613) 820-8313. ITT
 Components (613) 226-7406. Varah (613) 726-8884.
 Quebec City: Arrow/CESCO (418) 687-4231. Toronto:
 CESCO (416) 661-6220.
 Future (416) 638-4771. ITT Components
 (416) 735-1144. Varah (416) 842-8484.
 Vancouver: Future (604) 438-5545. Varah
 (604) 873-3211. Winnipeg: Varah (204) 633-6190. BL



TEXAS INSTRUMENTS

Creating useful products
 and services for you.

TI Worldwide Sales Offices

ALABAMA: Huntsville: 500 Wynn Drive. Suite 514. Huntsville, AL 35805. (205) 837-7530.

ARIZONA: Phoenix: 8825 N. 23rd Ave., Phoenix, AZ 85021. (602) 995-1007.

CALIFORNIA: Irvine: 17891 Cartwright Rd., Irvine, CA 92714. (714) 660-8187; Sacramento: 1900 Point West Way, Suite 171, Sacramento, CA 95815. (916) 929-1521; San Diego: 4333 View Ridge Ave., Suite B, San Diego, CA 92123. (619) 278-9601; Santa Clara: 5353 Betsy Ross Dr., Santa Clara, CA 95054. (408) 980-9000; Torrance: 690 Knox St., Torrance, CA 90502. (213) 217-7010; Woodland Hills: 21220 Erwin St., Woodland Hills, CA 91367. (818) 704-7759.

COLORADO: Aurora: 1400 S. Potomac Ave., Suite 101, Aurora, CO 80012. (303) 368-8000.

CONNECTICUT: Wallingford: 9 Barnes Industrial Park Rd., Barnes Industrial Park, Wallingford, CT 06492. (203) 269-0074.

FLORIDA: Ft. Lauderdale: 2765 N.W. 62nd St., Ft. Lauderdale, FL 33309. (305) 973-8502; Maitland: 2601 Maitland Center Parkway, Maitland, FL 32751. (305) 660-4600; Tampa: 5010 W. Kennedy Blvd., Suite 101, Tampa, FL 33609. (813) 870-6420.

GEORGIA: Norcross: 5515 Spalding Drive, Norcross, GA 30092. (404) 662-7900.

ILLINOIS: Arlington Heights: 515 W. Algonquin, Arlington Heights, IL 60005. (312) 640-2925.

INDIANA: Ft. Wayne: 2020 Inwood Dr., Ft. Wayne, IN 46815. (219) 424-5174; Indianapolis: 2346 S. Lynhurst, Suite J-400, Indianapolis, IN 46241. (317) 248-8555.

IOWA: Cedar Rapids: 373 Collins Rd. NE, Suite 200, Cedar Rapids, IA 52402. (319) 395-9550.

MARYLAND: Baltimore: 1 Rutherford Pl., 7133 Rutherford Rd., Baltimore, MD 21207. (301) 944-8600.

MASSACHUSETTS: Waltham: 504 Totten Pond Rd., Waltham, MA 02154. (617) 895-9100.

MICHIGAN: Farmington Hills: 39377 J. 12 Mile Rd., Farmington Hills, MI 48018. (313) 553-1500.

MINNESOTA: Eden Prairie: 11000 W. 78th St., Eden Prairie, MN 55344. (612) 828-9300.

MISSOURI: Kansas City: 8080 Ward Pkwy., Kansas City, MO 64114. (816) 523-2500; St. Louis: 11861 Westline Industrial Drive, St. Louis, MO 63141. (314) 569-7600.

NEW JERSEY: Iselin: 485 E. U.S. Route 1 South, Parkway Towers, Iselin, NJ 08830. (201) 750-1050.

NEW MEXICO: Albuquerque: 2820-D Broadbent Pkwy NE, Albuquerque, NM 87107. (505) 345-2555.

NEW YORK: East Syracuse: 6565 Collamer Dr., East Syracuse, NY 13057. (315) 463-9291; Endicott: 112 Nantcoke Ave., P.O. Box 618, Endicott, NY 13760. (607) 754-3900; Melville: 1 Huntington Quadrangle, Suite 3C10, P.O. Box 2936, Melville, NY 11747. (516) 454-8600; Pittsford: 2851 Clover St., Pittsford, NY 14534. (716) 385-6770; Poughkeepsie: 385 South Rd., Poughkeepsie, NY 12601. (914) 473-2900.

NORTH CAROLINA: Charlotte: 8 Woodlawn Green, Woodlawn Rd., Charlotte, NC 28210. (704) 527-0930; Raleigh: 2809 Highwoods Blvd., Suite 100, Raleigh, NC 27625. (919) 876-2725.

OHIO: Beachwood: 23408 Commerce Park Rd., Beachwood, OH 44122. (216) 464-6100; Dayton: Kingsley Bldg., 4124 Linden Ave., Dayton, OH 45432. (513) 258-3877.

OKLAHOMA: Tulsa: 7615 East 63rd Place, 3 Memorial Place, Tulsa, OK 74133. (918) 250-0633.

OREGON: Beaverton: 6700 SW 105th St., Suite 110, Beaverton, OR 97005. (503) 643-6758.

PENNSYLVANIA: Ft. Washington: 260 New York Dr., Ft. Washington, PA 19034. (215) 643-6450; Coraopolis: 420 Rouser Rd., 3 Airport Office Park, Coraopolis, PA 15108. (412) 771-8550.

PUERTO RICO: Hato Rey: Mercantil Plaza Bldg., Suite 505, Hato Rey, PR 00919. (809) 753-8700.

TEXAS: Austin: 12501 Research Blvd., P.O. Box 2909, Austin, TX 78723. (512) 250-7655; Richardson: 1001 E. Campbell Rd., Richardson, TX 75080.

(214) 680-5082; Houston: 9100 Southwest Frwy., Suite 231, Houston, TX 77036. (713) 773-6592; San Antonio: 1000 Central Parkway South, San Antonio, TX 78232. (512) 496-1779.

UTAH: Murray: 5201 South Green SE, Suite 200, Murray, UT 84107. (801) 266-8972.

VIRGINIA: Fairfax: 3001 Prosperity, Fairfax, VA 22031. (703) 649-1400.

WASHINGTON: Redmond: 5010 148th NE, Bldg B, Suite 107, Redmond, WA 98052. (206) 881-3080.

WISCONSIN: Brookfield: 450 N. Sunny Slope, Suite 150, Brookfield, WI 53005. (414) 765-7140.

CANADA: Nepean: 301 Moodie Drive, Mallon Center, Nepean, Ontario, Canada, K2H9C4.

(613) 726-1970; Richmond Hill: 280 Centre St. E., Richmond Hill, L4C1S1, Ontario, Canada.

(416) 884-9181; St. Laurent: Ville St. Laurent Quebec, 9460 Trans Canada Hwy., St. Laurent, Quebec, Canada H4S1R7. (514) 334-3635.

ARGENTINA: Texas Instruments Argentina S.A.I.C.F.: Esmeralda 130, 15th Floor, 1035 Buenos Aires, Argentina, 1 + 394-3008.

AUSTRALIA (& NEW ZEALAND): Texas Instruments Australia Ltd.: 6-10 Talavera Rd., North Ryde (Sydney), New South Wales, Australia 2113.

2 + 887-1122; 5th Floor, 418 St. Klida Road, Melbourne, Victoria, Australia 3004. 3 + 267-4677; 171 Philip Highway, Elizabeth, South Australia 5112. 8 + 295-2666.

AUSTRIA: Texas Instruments Ges.m.b.H.: Industriestrasse B/16, A-2345 Brunn/Gebirge, 2236 846210.

BELGIUM: Texas Instruments N.V. Belgium S.A.: Mercure Centre, Raketsstraat 100, Rue de la Fusée, 1130 Brussels, Belgium, 2720.60.00.

BRAZIL: Texas Instruments Electronicos do Brasil Ltda.: Rua Paes Leme, 524-7 Andar Pinheiros, 05424 Sao Paulo, Brazil, 0815-6166.

DENMARK: Texas Instruments A/S, Mairelundvej 46E, DK-2730 Herlev, Denmark. 2 - 91 74 00.

FINLAND: Texas Instruments Finland Oy: Teollisuuskatu 19D 00511 Helsinki 51, Finland, (90) 701-3133.

FRANCE: Texas Instruments France: Headquarters and Prod. Plant, BP 05, 06270 Villeneuve-Loubet, (93) 20-01-01; Paris Office, BP 87-810 Avenue Morane-Saulnier, 78141 Velizy-Villacoublay.

(3) 946-97-12; Lyon Sales Office, L'Oree D'Ecully, Bâtiment B, Chemin de la Forestiere, 69130 Ecully, (7) 833-04-40; Strasbourg Sales Office, Le Sebastopol 3, Quai Kleber, 67055 Strasbourg Cedex.

(68) 22-12-66; Rennes, 23-25 Rue du Puits Mauger, 35100 Rennes, (99) 31-54-86; Toulouse Sales Office, Le Petrole-2, Chemin du Pigeonnier de la Copiere, 31100 Toulouse, (61) 44-18-19; Marseille Sales Office, Nielly Paradis-146 Rue Paradis, 13006 Marseille, (91) 37-25-30.

GERMANY (Fed. Republic of Germany): Texas Instruments Deutschland GmbH: Haggrortstrasse 1, D-8050 Freising, 8161 + 80-4591; Kurlfuerstendam 135156, D-1000 Berlin 15, 30 + 882-7365; III, Hagen 43/Kibelstrasse, 19, D-4300 Essen, 201+24200; Frankfurter Allee 6/8, D-6236 Eschborn 1, 06196 + 8070; Hamburgersstrasse 11, D-2000 Hamburg 76, 040 + 220-1154; Kirchhorsterstrasse 2, D-3000 Hannover 51, 511 + 648021; Maybachstrasse 11, D-7302 Ostfildern 2-Nellingen, 711 + 547001; Mixkirkong 19, D-2000 Hamburg 60, 40 + 637 + 0061; Postfach 1309, Roonstrasse 16, D-5400 Koblenz, 261 + 35044.

HONG KONG (+ PEOPLES REPUBLIC OF CHINA): Texas Instruments Asia Ltd.: 8th Floor, World Shipping Ctr., Harbour City, 7 Canton Rd., Kowloon, Hong Kong. 3 + 722-1223.

IRELAND: Texas Instruments (Ireland) Limited: Brewery Rd., Stillorgan, County Dublin, Eire, 1 831311.

ITALY: Texas Instruments Semiconduttori Italia Spa: Viale Delle Scienze, 1, 02015 Citta di Viterbo (Rieti), Italy, 746 694-1; Via Salaria KM 24 (Piazzale Cosma), Monterotondo Scalo (Rome), Italy, 6 + 9003241; Viale Europa, 38-44, 20093 Cologno Monzese (Milano), 2 2532541; Corso Svizzera, 185, 10100 Torino, Italy, 11 774545; Via J. Barozzi 6, 40100 Bologna, Italy, 51 355551.

JAPAN: Texas Instruments Asia Ltd.: 4F Aoyama Fyji Bldg., 6-12, Kita Aoyama 3-Chome, Minato-ku, Tokyo, Japan 107, 3-438-2111; Osaka Branch, 5F, Nishiso Iwai Bldg., 30 Imabashi 3-Chome, Higashi-ku, Osaka, Japan 541, 06-204-1881; Nagoya Branch, 7F Daini Toyota West Bldg., 10-27, Meieki 4-Chome, Nakamura-ku Nagoya, Japan 450, 52-583-6691.

KOREA: Texas Instruments Supply Co.: 3rd Floor, Samon Bldg., Yuksam-Dong, Gangnam-ku, 135 Seoul, Korea. 2 + 482-8000.

MEXICO: Texas Instruments de Mexico S.A.: Mexico City, AV Reforma No. 450 - 10th Floor, Mexico, D.F., 06600, 5 + 514-3003.

MIDDLE EAST: Texas Instruments No. 13, 1st Floor Mannai Bldg., Diplomatic Area, P.O. Box 26335, Manama Bahrain, Arabian Gulf, 973 + 274681.

NETHERLANDS: Texas Instruments Holland B.V., P.O. Box 12995, (Bullewijk) 1100 CB Amsterdam, Zuid-Oost, Holland 20 + 5602911.

NORWAY: Texas Instruments Norway A/S: PB106, Retstad 131, Oslo 1, Norway, (2) 155099.

PHILIPPINES: Texas Instruments Asia Ltd.: 14th Floor, Ba. Lepanto Bldg., 8747 Paseo de Roxas, Makati, Metro Manila, Philippines, 2 + 8189867.

PORTUGAL: Texas Instruments Equipamento Electronico (Portugal) Lda.: Rua Eng. Frederico Ulrich, 2650 Moreira Da Maia, 4470 Maia, Portugal, 2-948-1003.

SINGAPORE (+ INDIA, INDONESIA, MALAYSIA, THAILAND): Texas Instruments Asia Ltd.: 12 Lorong Bakar Batu, Unit 01-02, Kolaba Ayer Industrial Estate, Republic of Singapore, 747-2255.

SPAIN: Texas Instruments Espana, S.A.: C/Jose Lapraz Galdiano No. 6, Madrid 16, 1458 14.58

SWEDEN: Texas Instruments International Trade Corporation (Sverigefilialen): Box 39103, 10054 Stockholm, Sweden, 8 - 235480.

SWITZERLAND: Texas Instruments, Inc., Feldstrasse 6, CH-8953 Dietikon (Zuerich) Switzerland, 1-740 2220.

TAIWAN: Texas Instruments Supply Co.: Room 903, 205 Tun Hwan Rd., 71 Sung-Kiang Road, Taipei, Taiwan, Republic of China. 2 + 521-9321.

UNITED KINGDOM: Texas Instruments Limited: Manton Lane, Bedford, MK41 7PA, England, 0234 67466; St. James House, Wellington Road North, Stockport, SK4 2RT, England, 61 + 442-7162.



TEXAS INSTRUMENTS

Creating useful products
and services for you

BL



**TEXAS
INSTRUMENTS**

Creating useful products
and services for you.